



# TMO Rainier Antenna Test Report

Jan. 18, 2023

Prepared by AK Chen / Shian Chuang

# Test Information

Item	Description
Brand Name	T-Mobile
Equipment	T-Mobile 5G Gateway, TMO-G4SE
Test Location	8F, No. 3-1, YuanQu St. Taipei, Taiwan 115 R.O.C.
Test Condition	Radiation
Test Engineer	AK Chen, Sercomm
Test Environment	ETS-Lindgren AMS-8500 Antenna Measurement Chamber
Test Date	May. 03, 2022 ~ Dec. 30, 2022

# Test Configuration

ETS-Lindgren AMS-8500 antenna measurement system with a size of  $7.32(L) \times 3.66(W) \times 3.66(H)$  m<sup>3</sup> is used for antenna performance test, which is based on the great-circle test method defined by CTIA. The multi-axis positioning system (MAPS) rotates the DUT around two orthogonal axes for full spherical coverage.

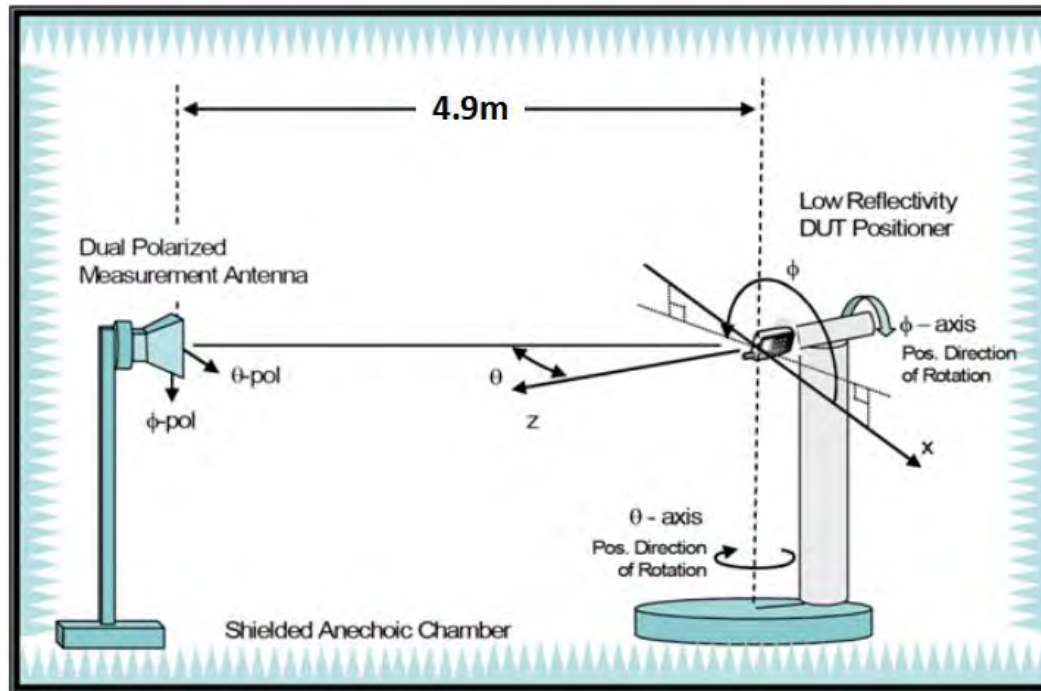

# Test Setup & Procedure

1. Fix the DUT on the dielectric support structure and connect the feeding cable to the antenna used for test
2. Set measurement parameters such as frequency range and sampling angle
3. Perform test and then get far-field data (radiation pattern, gain, efficiency)
4. Repeat test procedure for other antennas

# Test Equipment & Calibration

Network analyzer and reference antennas are used for calibration. Path loss and cable loss for different frequency bands can be checked and calculated.

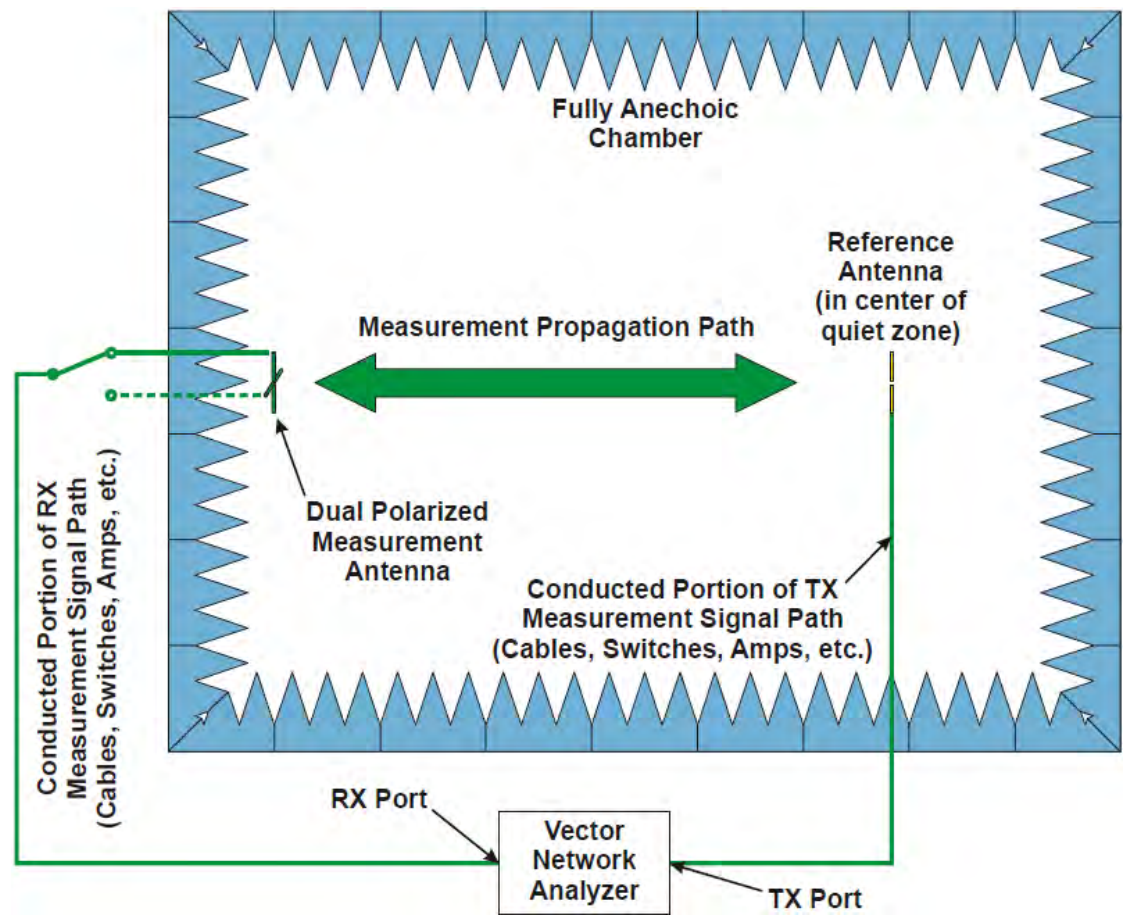



# Test Equipment & Calibration

Instrument	Brand	Characteristics	Model No.	Serial No.	Calibration Due Date
Precision Sleeve Dipole	ETS-Lindgren	600 MHz ~ 800 MHz	3126-700	00169715	May 21, 2024
Precision Sleeve Dipole	ETS-Lindgren	800 MHz ~ 1000 MHz	3126-900	00169592	May 21, 2024
Precision Sleeve Dipole	ETS-Lindgren	1400 MHz ~ 1700 MHz	3126-1550	00164599	May 21, 2024
Precision Sleeve Dipole	ETS-Lindgren	1700 MHz ~ 2000 MHz	3126-1850	00169588	May 21, 2024
Precision Sleeve Dipole	ETS-Lindgren	2000 MHz ~ 2300 MHz	3126-2150	00169593	May 21, 2024
Precision Sleeve Dipole	ETS-Lindgren	2300 MHz ~ 2700 MHz	3126-2500	00169597	May 21, 2024
Precision Sleeve Dipole	ETS-Lindgren	5000 MHz ~ 6000 MHz	3126-5500	00169728	May 21, 2024
Horn Antenna	SCHWARZBECK	1 GHz ~ 18 GHz	BBHA 9120D	BBHA 9120D-1294	Apr. 07, 2024
EMQuest Antenna Measurement Software	ETS-Lindgren	Control chamber system	EMQ-100	1437	Non-Calibration Required

# Outline

---

- Antenna Structure & Placement
- Return Loss & Isolation
- Radiation Pattern
- Peak Gain & Efficiency

# Antenna Structure & Placement

Ant No.	Operating Band	Type	Material	Feeding	Conn.	Dimension
Ant 0	LB Tx/Rx	PIFA	PCB	Cable	I-pex (同等級)	85 x 11.2 x 0.4 mm <sup>3</sup>
Ant 1	LB Rx MHB Rx	PIFA	FPCB	Spring	NA	60.52 x 17.7 x 13.56 mm <sup>3</sup>
Ant 2	MHB Tx/Rx UHB Tx/Rx	PIFA	FPCB	Spring	NA	60.52 x 17.7 x 13.56 mm <sup>3</sup>
Ant 3	LB Rx MHB Rx	PIFA	FPCB	Spring	NA	60.52 x 17.7 x 13.56 mm <sup>3</sup>
Ant 4	LB Rx MHB Tx/Rx UHB Tx/Rx	PIFA	FPCB	Spring	NA	60.52 x 17.7 x 13.56 mm <sup>3</sup>



# Antenna Structure & Placement

Ant No.	Operating Band	Type	Material	Feeding	Conn.	Dimension
Ant 5 & Ant 6	UHB Tx/Rx	Dipole	PCB	Cable	I-pex (同等級)	33.5 x 9.25 x 0.4 mm <sup>3</sup>
DA2	MHB Tx/Rx UHB Tx/Rx	Dipole	PCB	Cable	I-pex (同等級)	105 x 22 x 0.4 mm <sup>3</sup>
DA4	LB Rx MHB Tx/Rx UHB Tx/Rx	Dipole	PCB	Cable	I-pex (同等級)	140 x 22 x 0.4 mm <sup>3</sup>
WF0 & WF3	WiFi 2.4G/5G	Dipole	PCB	Cable	I-pex (同等級)	35 x 10 x 0.4 mm <sup>3</sup>
WF1 & WF2	WiFi 2.4G/5G	PIFA	FPCB	Cable	I-pex (同等級)	23.35 x 10.35 x 10.79 mm <sup>3</sup>
GPS	L1	Dipole	PCB	Cable	I-pex (同等級)	50 x 10 x 0.4 mm <sup>3</sup>
BT	2.4G	Dipole	PCB	Cable	I-pex (同等級)	35 x 10 x 0.4 mm <sup>3</sup>

# Return Loss – Ant 0

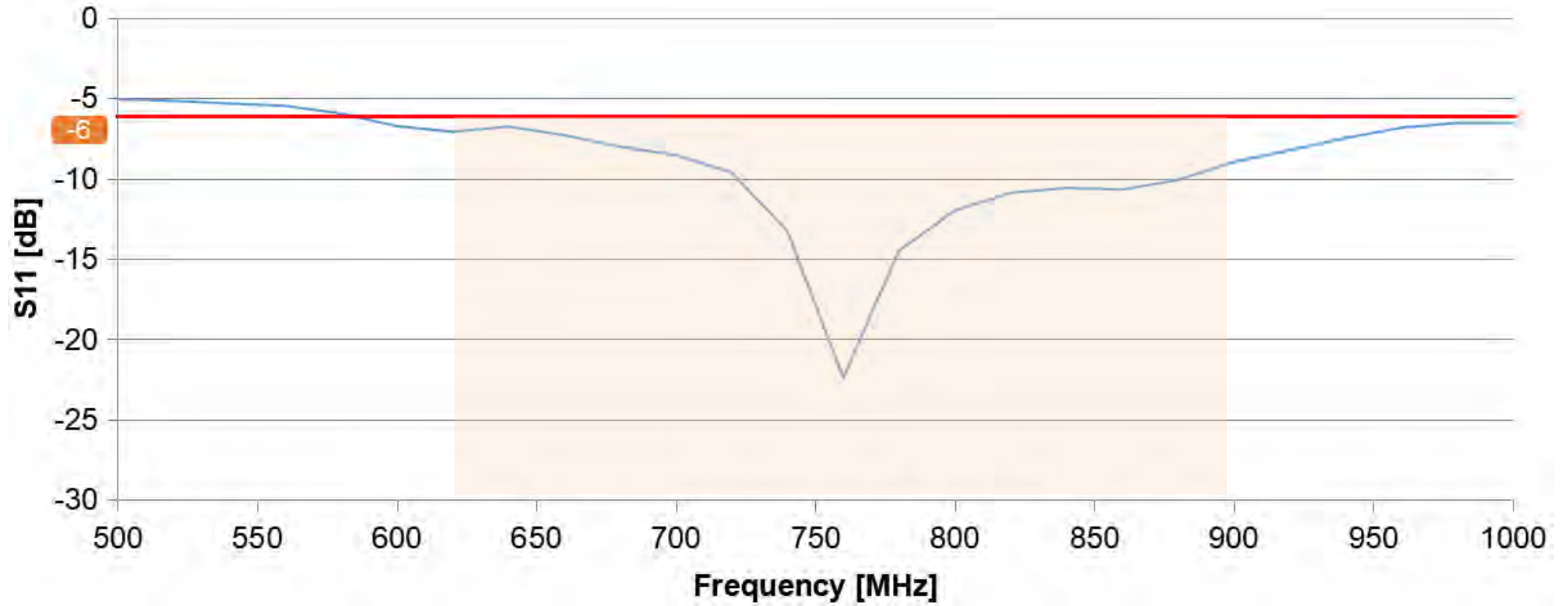

	n71			B12			B5		
Freq. (MHz)	617	663	698	699	716	746	824	849	894
Return Loss (dB)	-7.1	-7.31	-8.56	-8.56	-9.62	-13.3	-10.9	-10.6	-8.98

# Return Loss – Ant 1

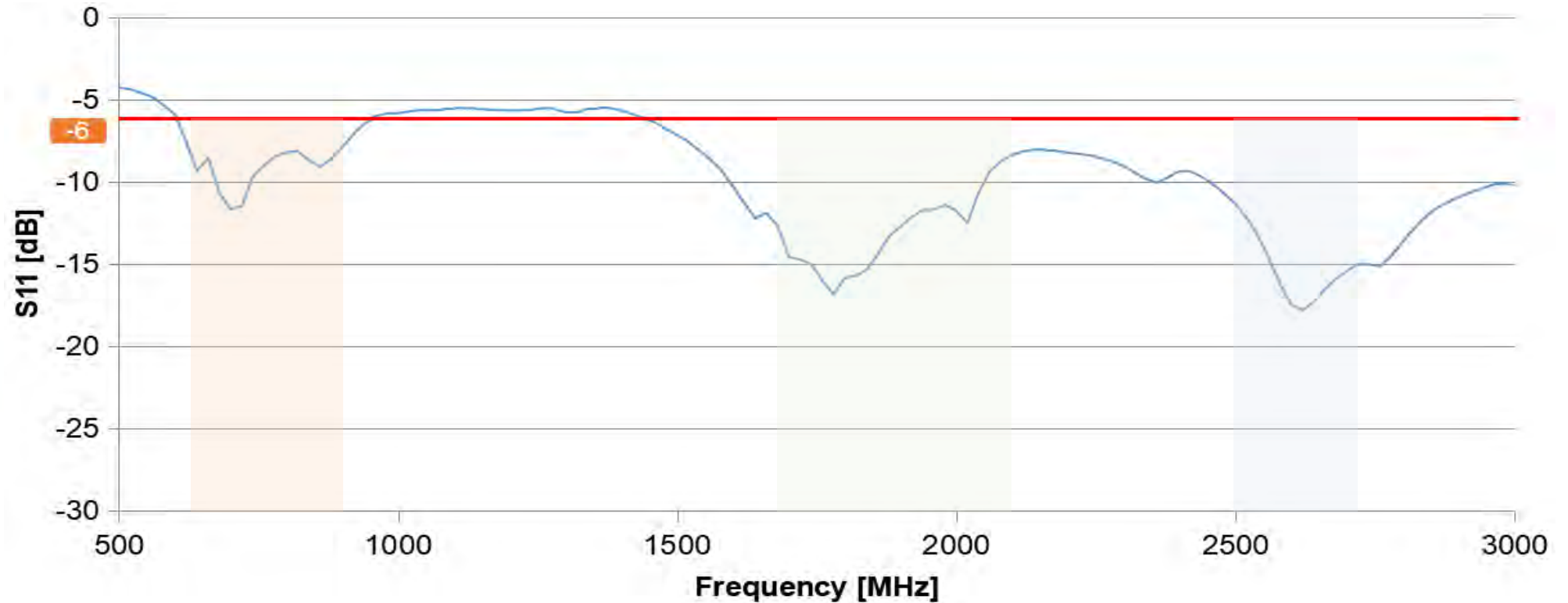

	n71			B12			B5		
Freq. (MHz)	617	634	652	729	737	746	869	880	894
Return Loss (dB)	-7.5	-9.3	-8.6	-11.5	-9.7	-9.0	-9.1	-8.6	-7.9

	B66			B2/B25			n41		
Freq. (MHz)	2110	2140	2170	1930	1960	1990	2496	2600	2690
Return Loss (dB)	-8.4	-8.1	-8.2	-12.2	-11.7	-11.8	-11.4	-17.5	-15.4

# Return Loss – Ant 2

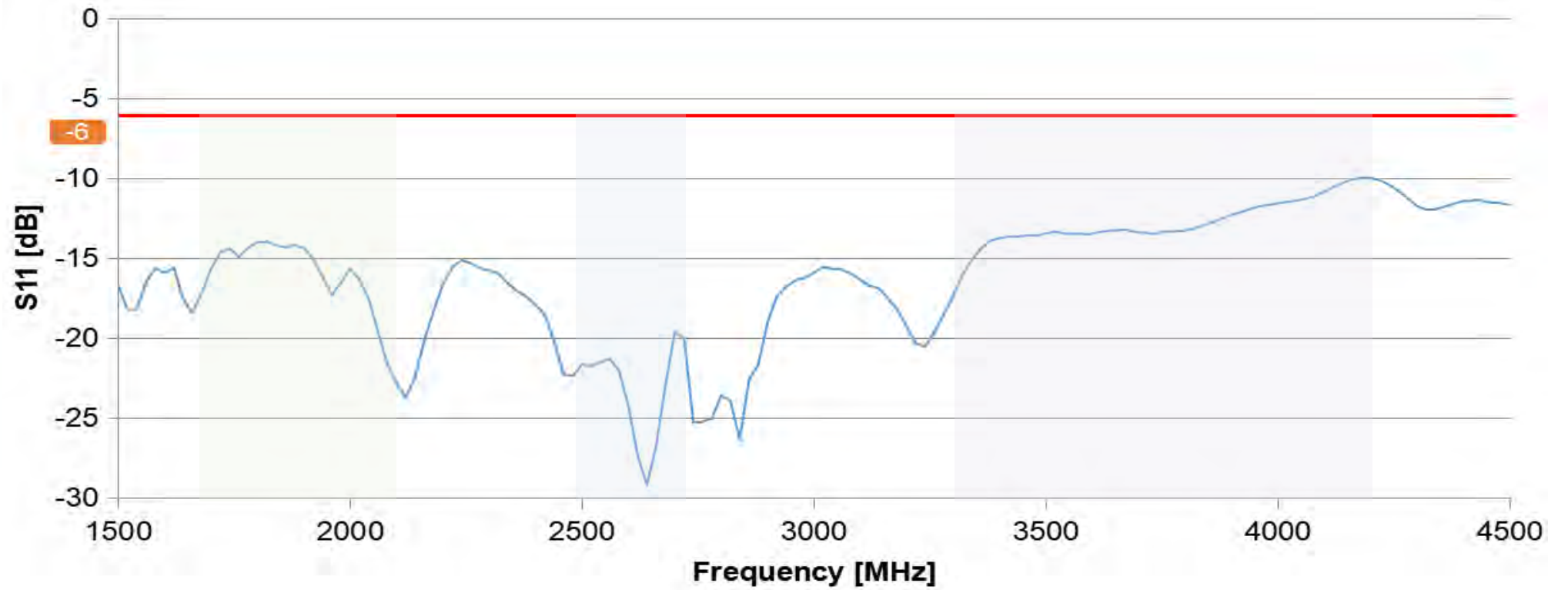

	B66			B2/B25			n41			n77		
Freq. (MHz)	1710	1780	2150	1850	1910	1990	2496	2600	2690	3300	3700	4200
Return Loss (dB)	-15.7	-14.4	-20.2	-14.2	-14.4	-16.6	-21.7	-24.3	-19.6	-17.4	-13.4	-10.0

# Return Loss – Ant 3

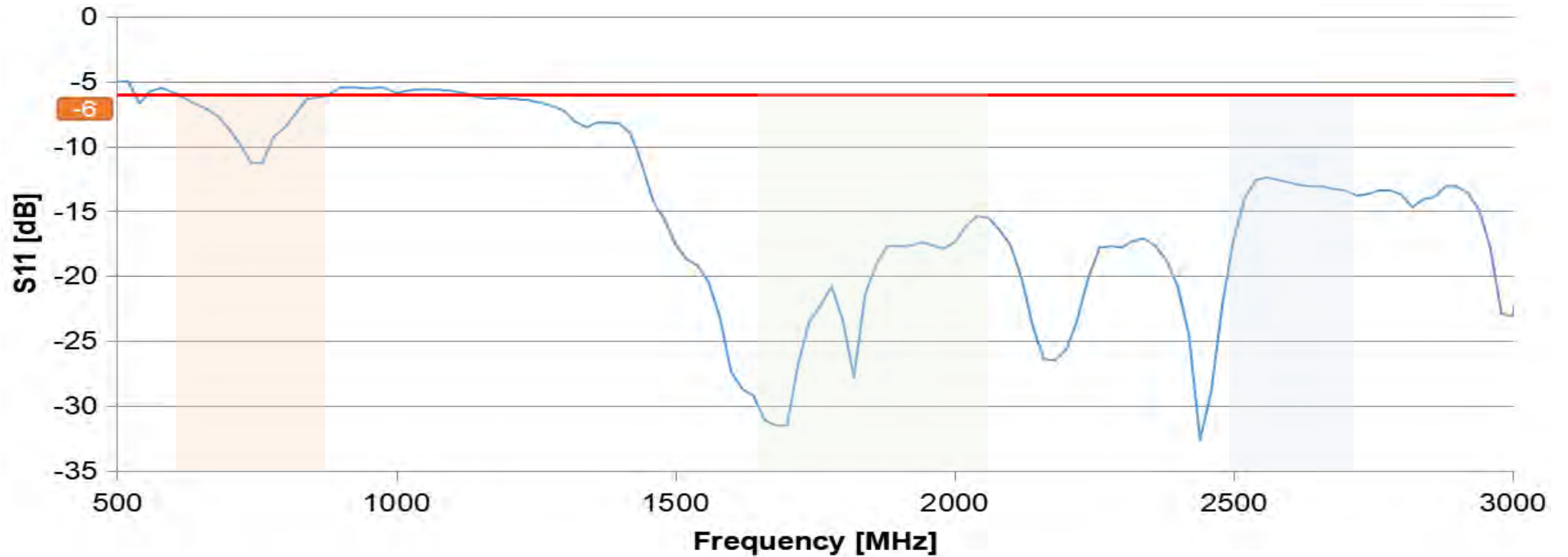

	n71			B12			B5		
Freq. (MHz)	617	634	652	729	737	746	869	880	894
Return Loss (dB)	-6.3	-6.7	-7.1	-9.8	-11.3	-11.3	-6.7	-6.3	-6.0

	B66			B2/B25			n41		
Freq. (MHz)	2110	2140	2170	1930	1960	1990	2496	2600	2690
Return Loss (dB)	-17.6	-23.8	-26.5	-17.7	-17.6	-17.4	-17.2	-12.8	-13.4

# Return Loss – Ant 4

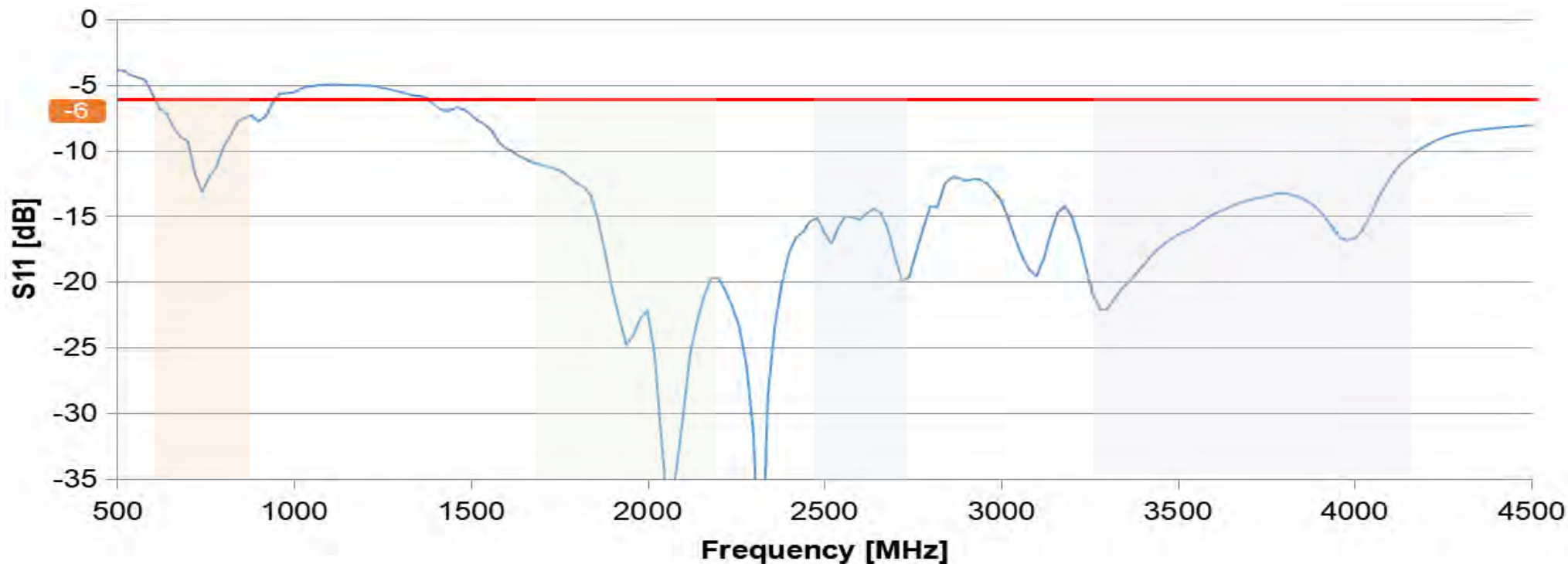

	n71			B12			B5		
Freq. (MHz)	617	634	652	729	737	746	869	880	894
Return Loss (dB)	-6.8	-7.2	-8.3	-11.8	-13.2	-12.0	-7.5	-7.3	-7.8

	B66			B2/B25			n41			n77		
Freq. (MHz)	1710	1780	2150	1850	1910	1990	2496	2600	2690	3300	3700	4200
Return Loss (dB)	-11.1	-12.1	-21.1	-13.4	-20.6	-22.8	-16.2	-15.3	-18.1	-22.1	-13.8	-9.7



# Return Loss – Ant 5

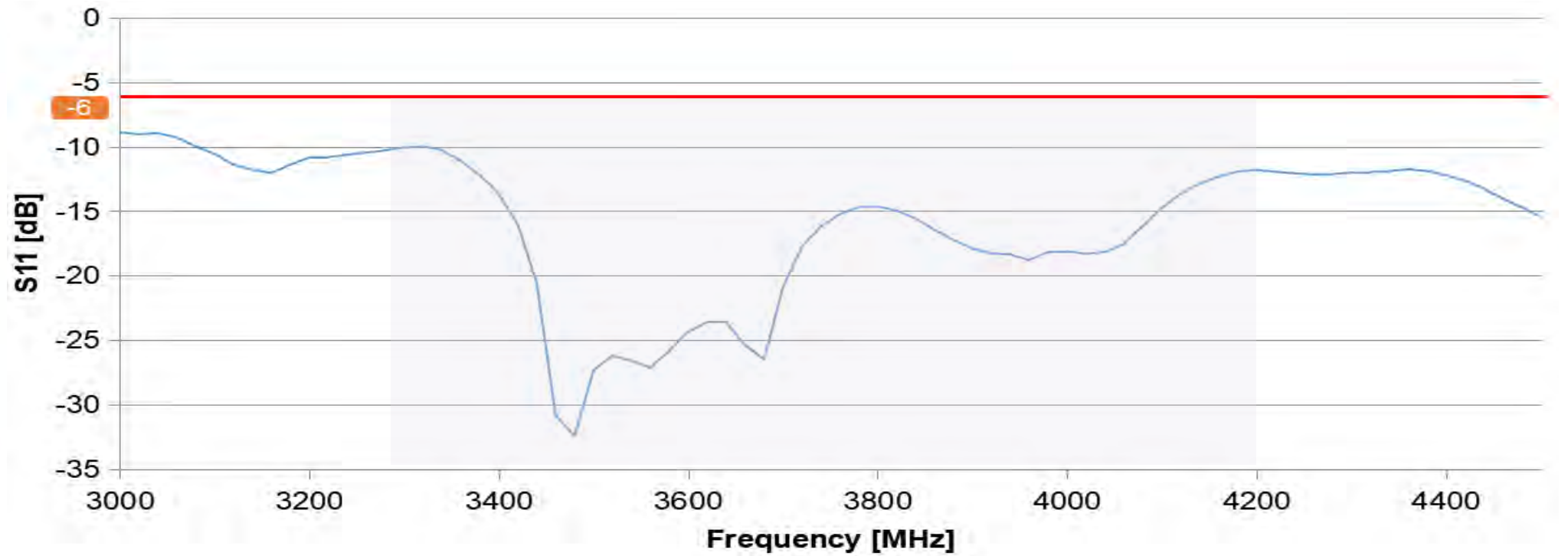

	n77		
Freq. (MHz)	3300	3700	4200
Return Loss (dB)	-10.1	-20.9	-11.8

# Return Loss – Ant 6

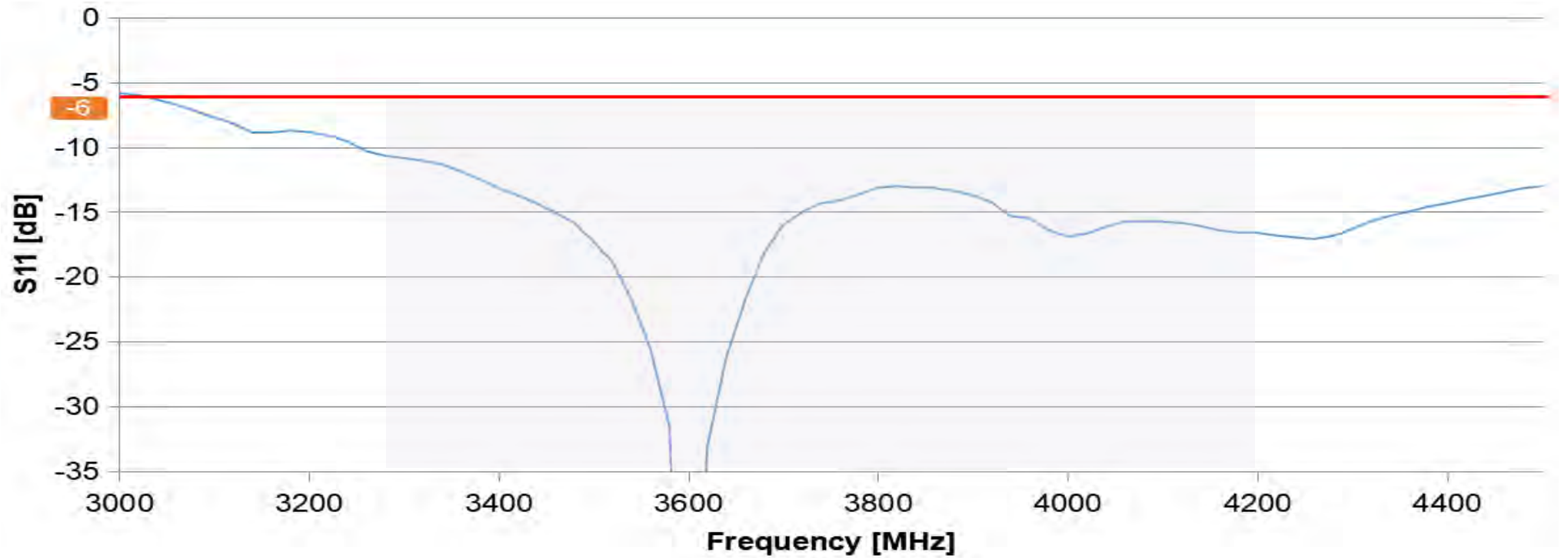

	n77		
Freq. (MHz)	3300	3700	4200
Return Loss (dB)	-10.9	-16.0	-16.6

# Return Loss – DA2

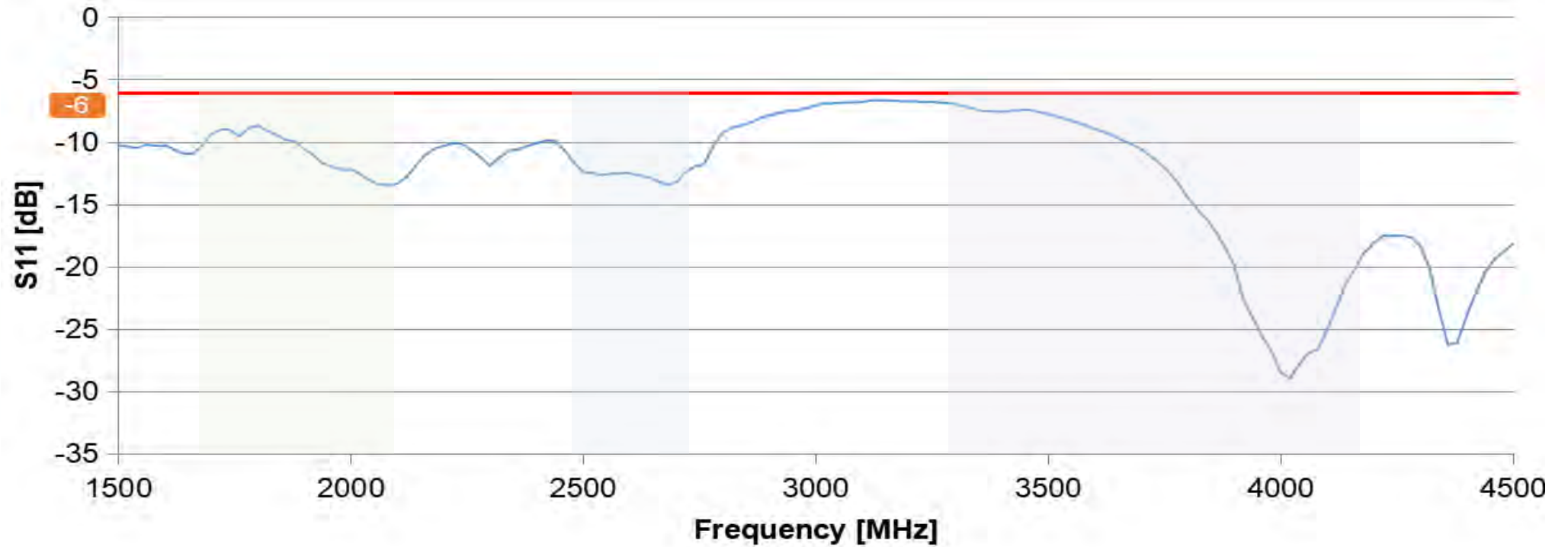

	B66			B2/B25			n41			n77		
Freq. (MHz)	1710	1780	2150	1850	1910	1990	2496	2600	2690	3300	3700	4200
Return Loss (dB)	-9.4	-8.9	-11.1	-9.5	-10.6	-12.2	-12.5	-12.5	-13.3	-7.0	-10.6	-18.1

# Return Loss – DA4

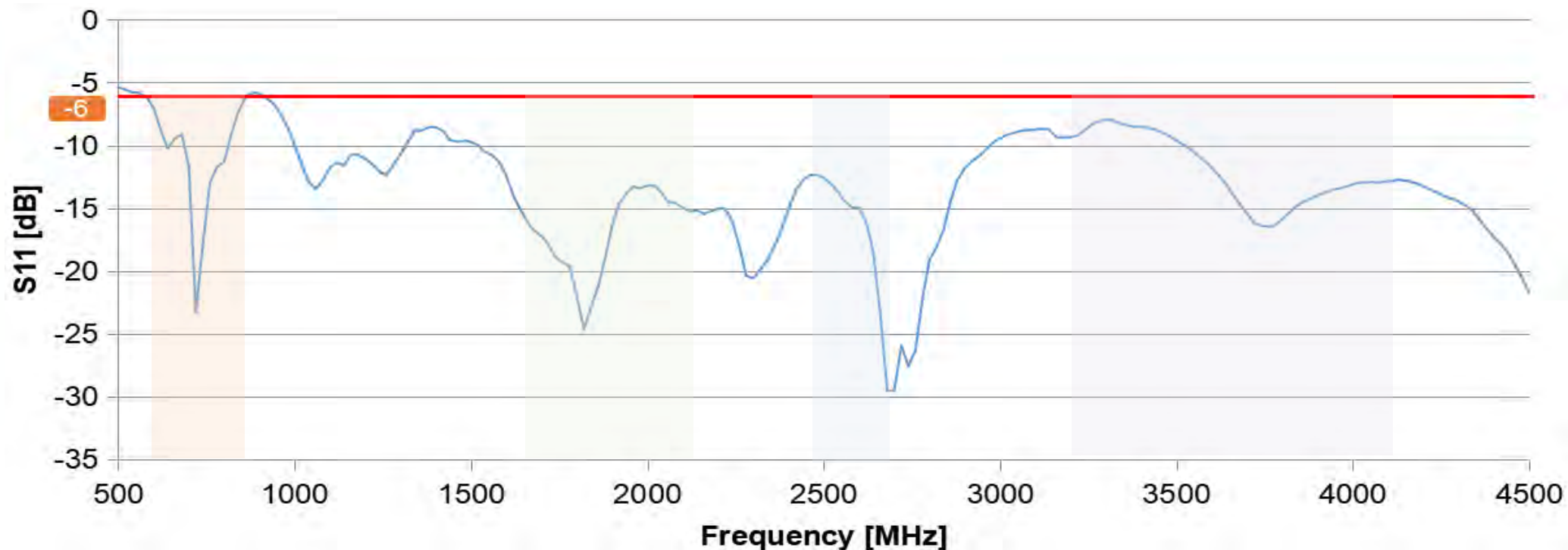

	n71			B12			B5		
Freq. (MHz)	617	634	652	729	737	746	869	880	894
Return Loss (dB)	-8.7	-10.2	-9.4	-23.3	-17.9	-13.0	-6.4	-6.2	-6.0

	B66			B2/B25			n41			n77		
Freq. (MHz)	1710	1780	2150	1850	1910	1990	2496	2600	2690	3300	3700	4200
Return Loss (dB)	-17.2	-19.6	-15.5	-22.9	-16.4	-13.4	-12.6	-15.0	-29.5	-8.0	-15.4	-13.3

# Return Loss – GPS

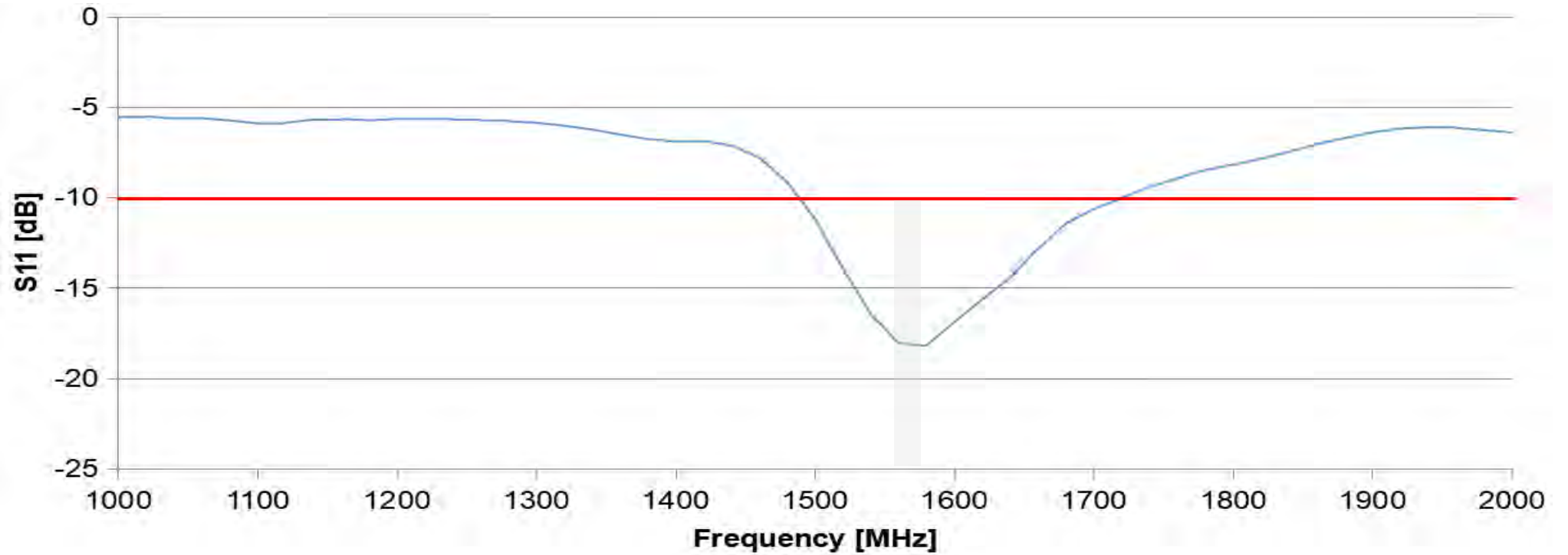

	GPS		
Freq. (MHz)	1570	1575	1580
Return Loss (dB)	-18.1	-18.1	-18.2

# Return Loss – WF0

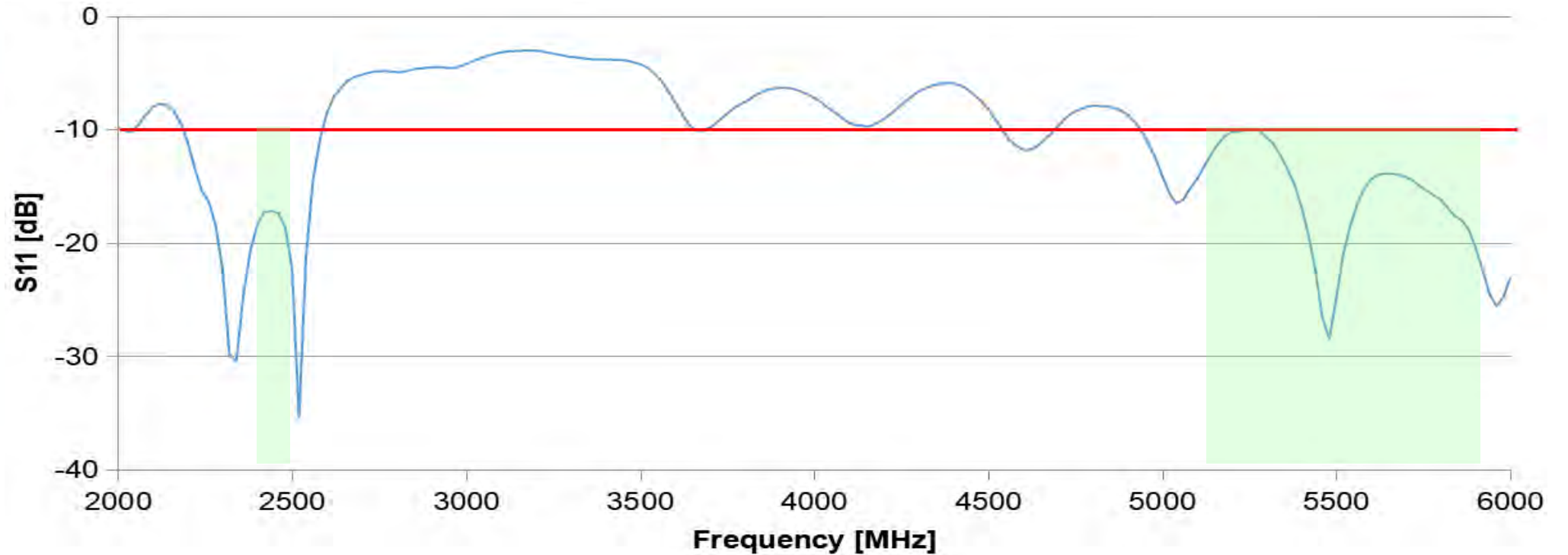

	2.4G			5G		
Freq. (MHz)	2400	2450	2500	5150	5500	5850
Return Loss (dB)	-18.4	-17.4	-22.3	-12.2	-24.9	-17.6



# Return Loss – WF1

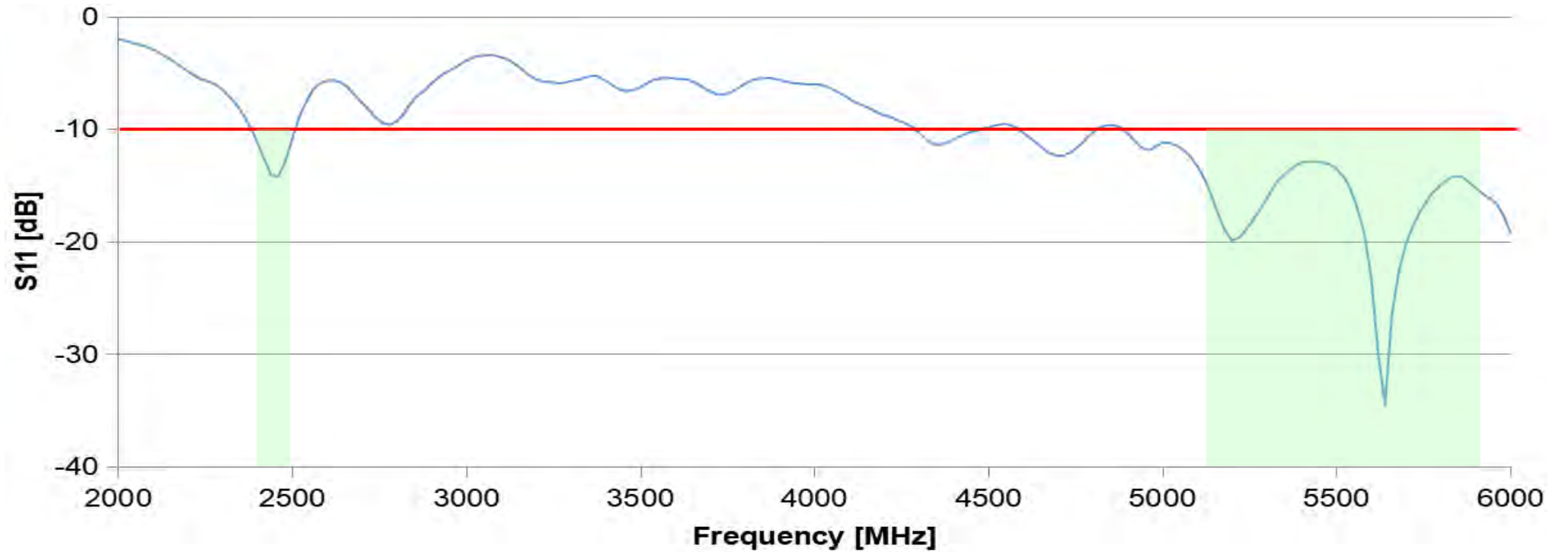

	2.4G			5G		
Freq. (MHz)	2400	2450	2500	5150	5500	5850
Return Loss (dB)	-11.1	-14.2	-10.9	-15.8	-13.5	-14.2

# Return Loss – WF2

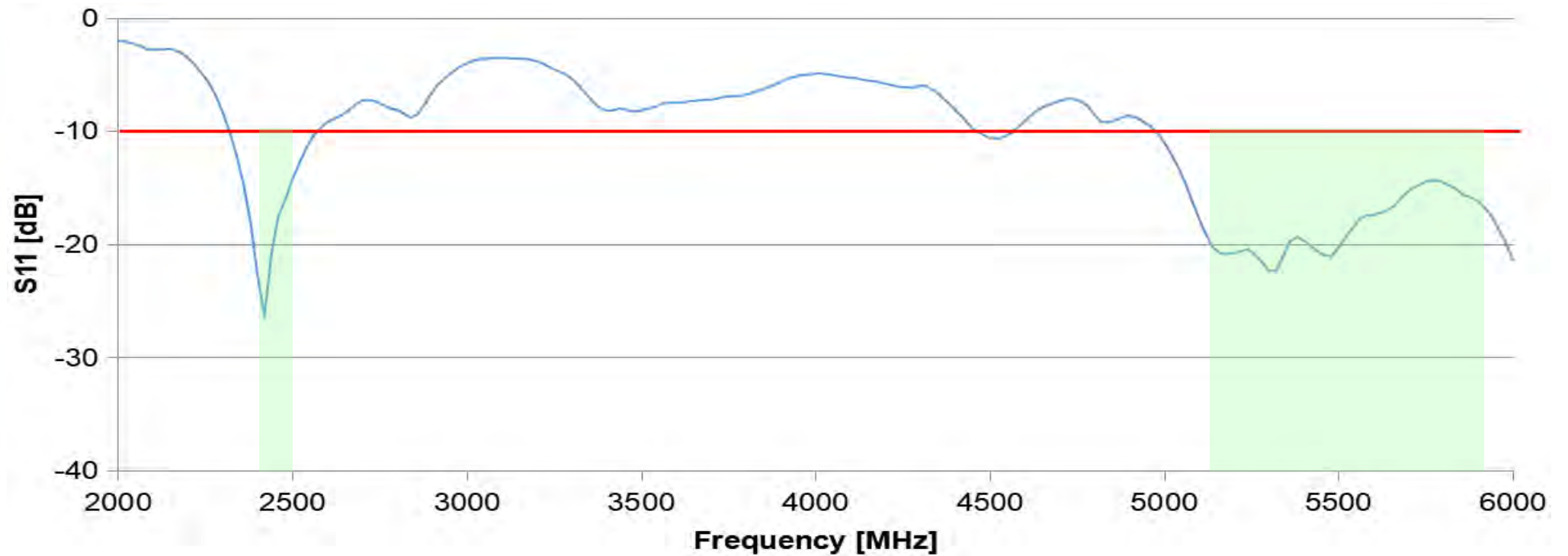

	2.4G			5G		
Freq. (MHz)	2400	2450	2500	5150	5500	5850
Return Loss (dB)	-22.7	-17.5	-14.3	-20.3	-20.3	-15.2

# Return Loss – WF3

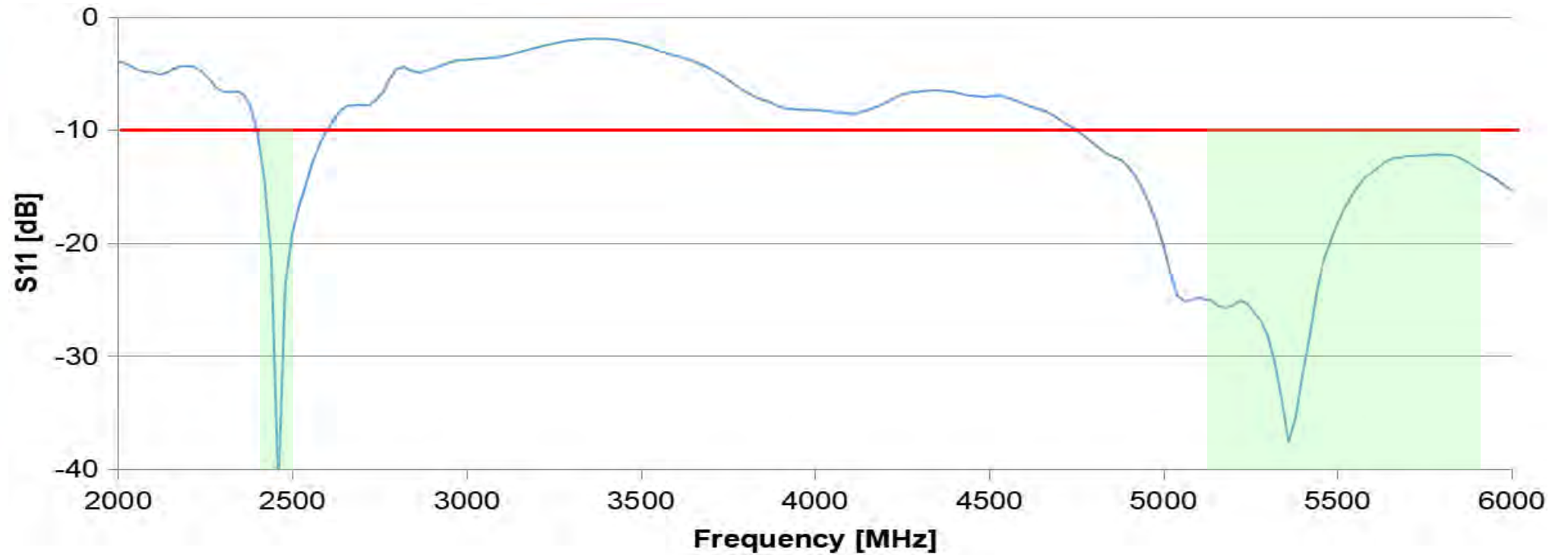

	2.4G			5G		
Freq. (MHz)	2400	2450	2500	5150	5500	5850
Return Loss (dB)	-10.2	-41.8	-19.2	-25.1	-18.3	-12.3

# Return Loss – BT

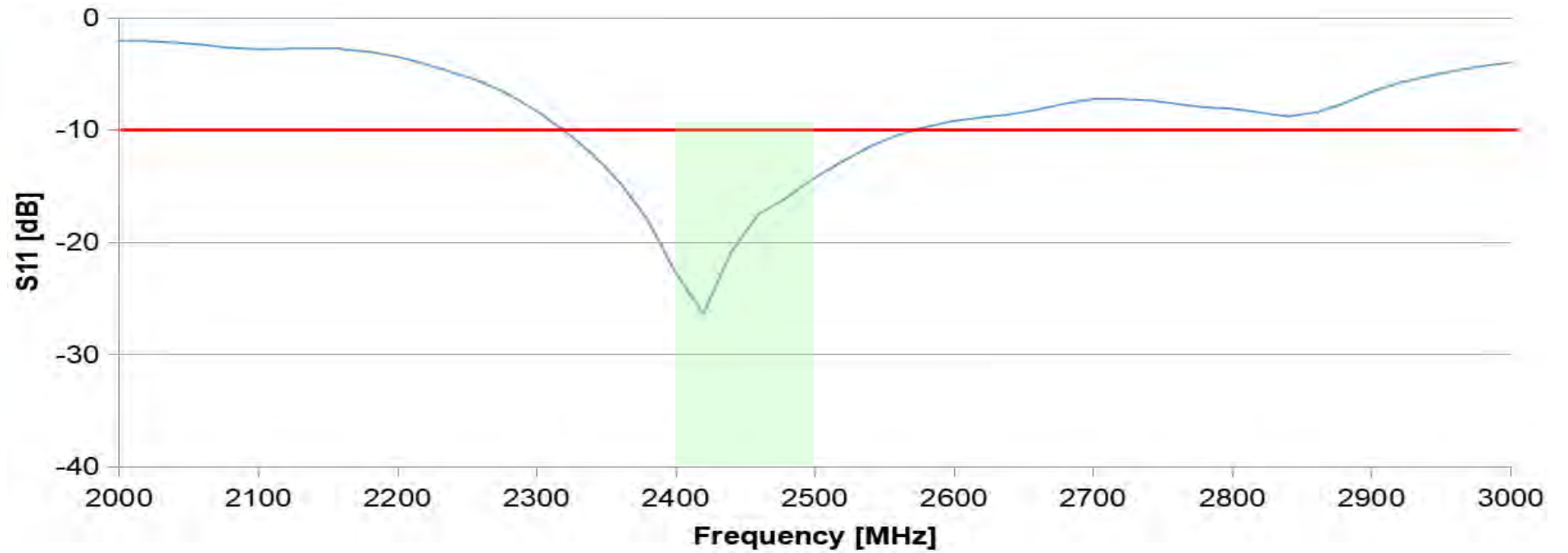

	2.4G		
Freq. (MHz)	2400	2450	2500
Return Loss (dB)	-20.2	-16.4	-14.7



# Isolation – LTE/5G NR

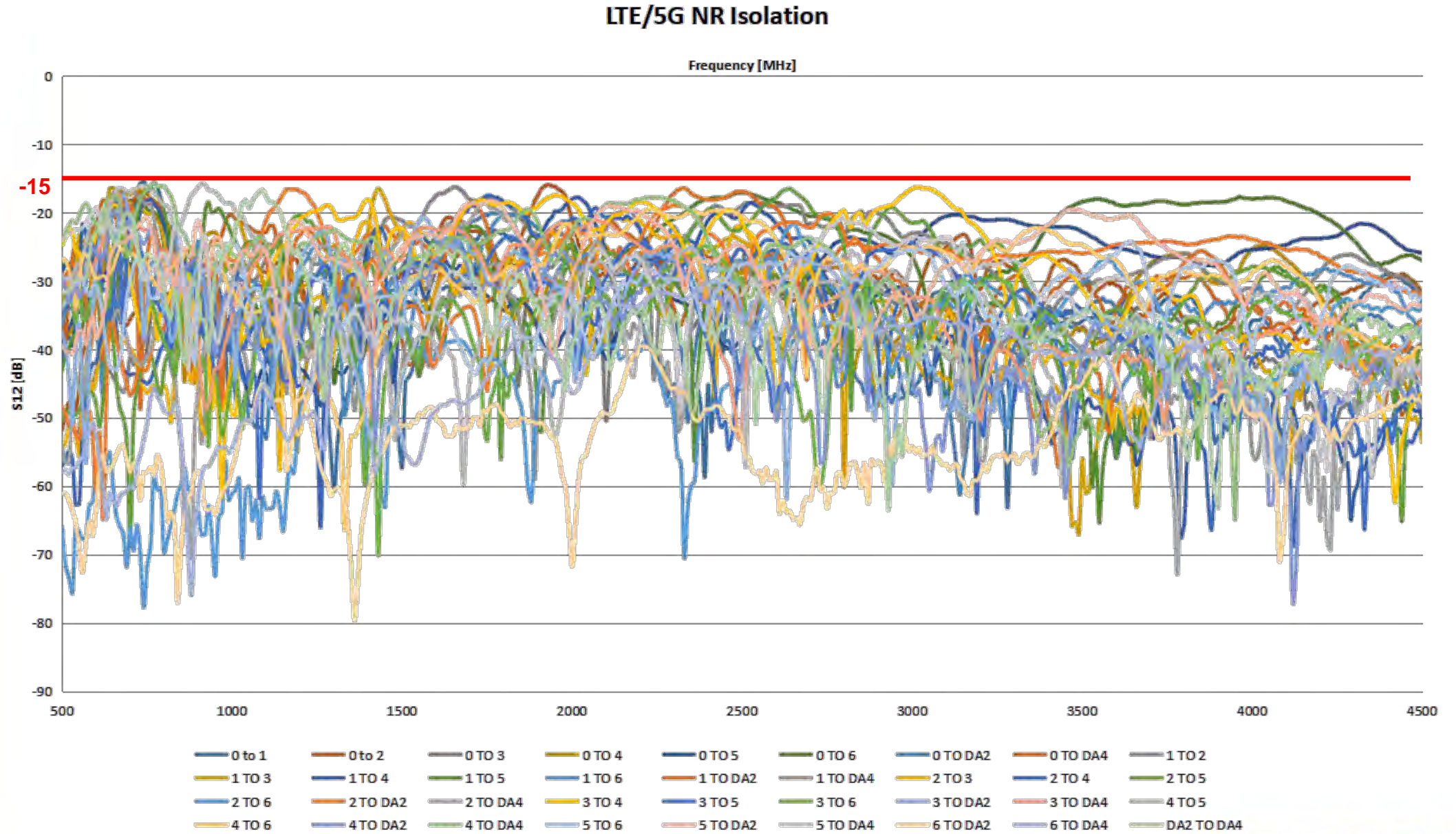

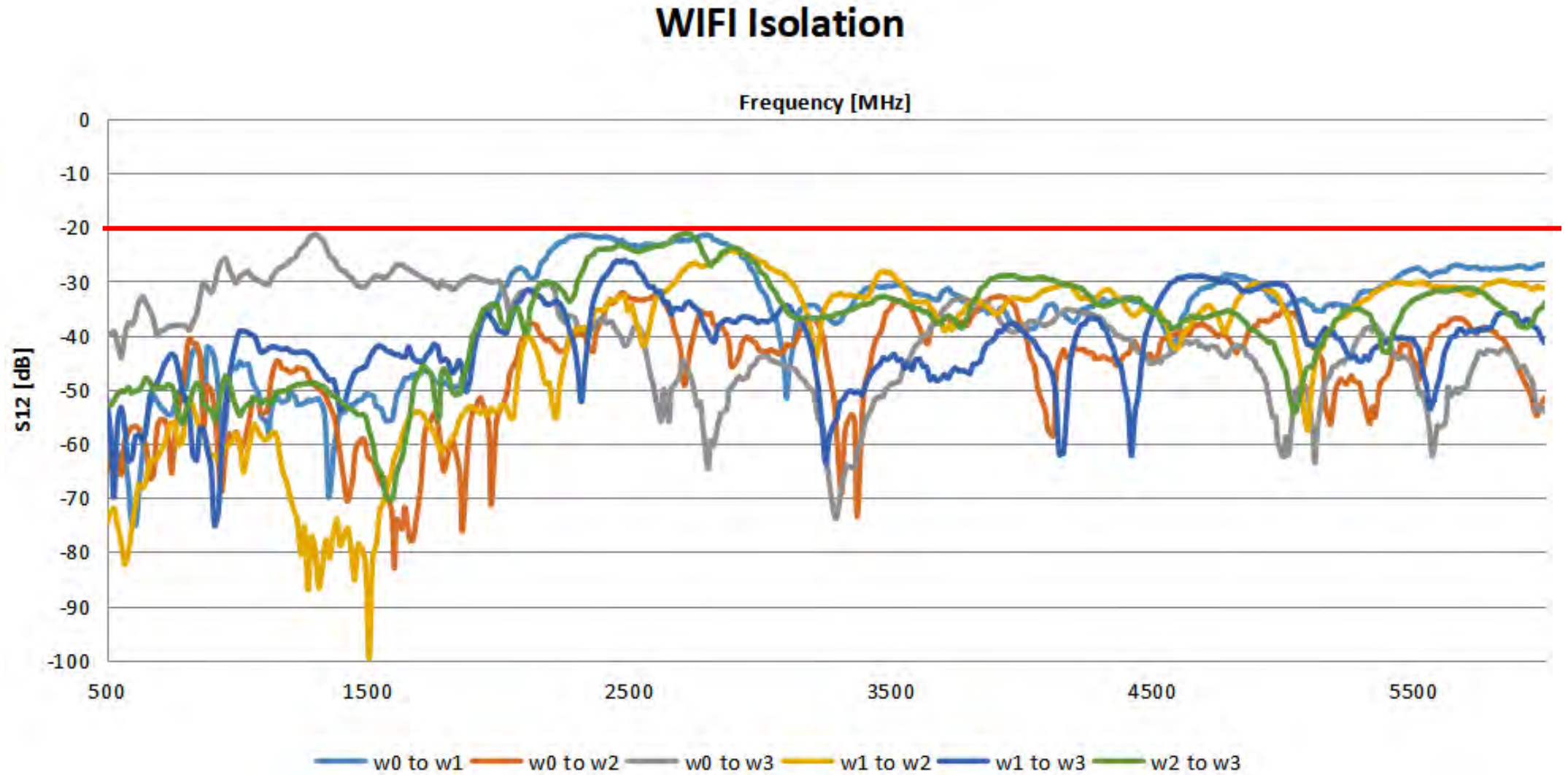



# Isolation – WIFI 0 to LTE/5G NR

## WIFI0 to LTE/5G NR Isolation

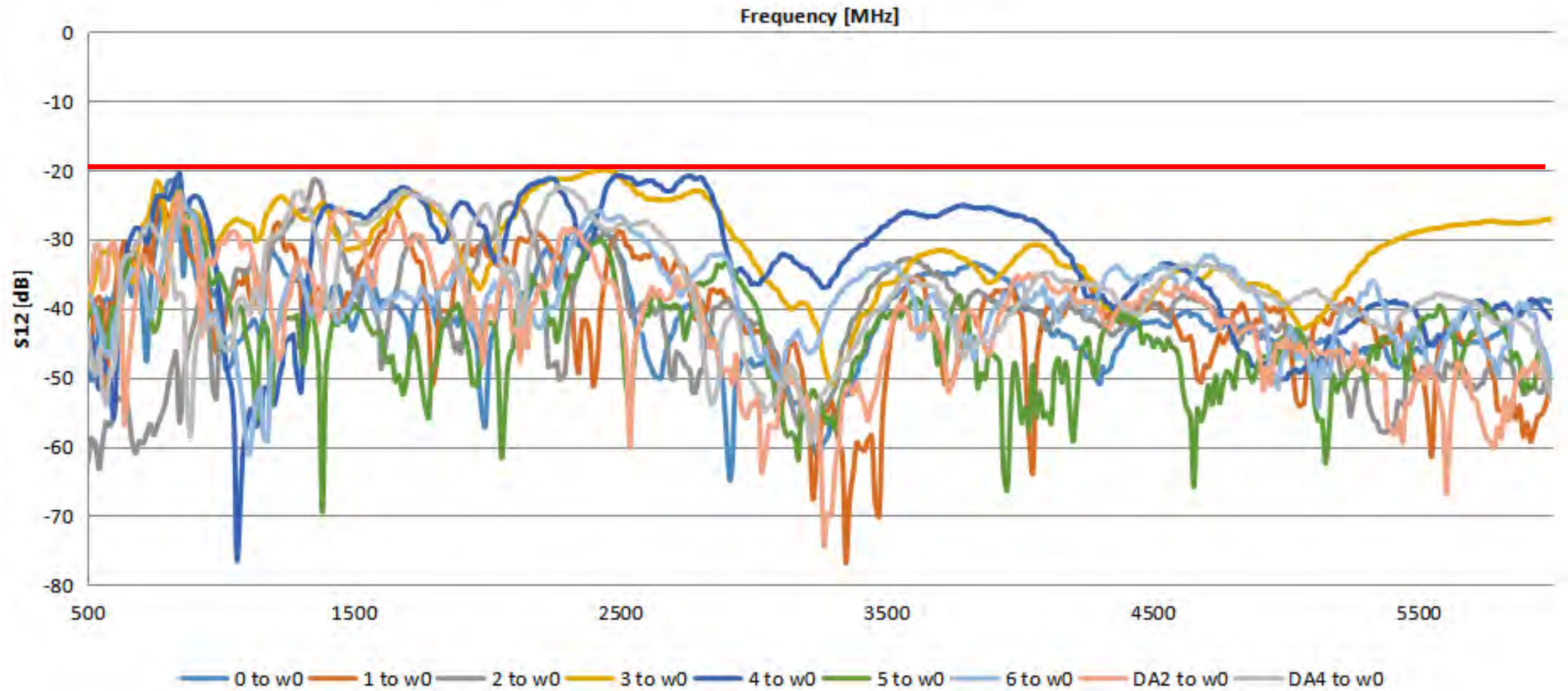

# Isolation – WIFI 1 to LTE/5G NR

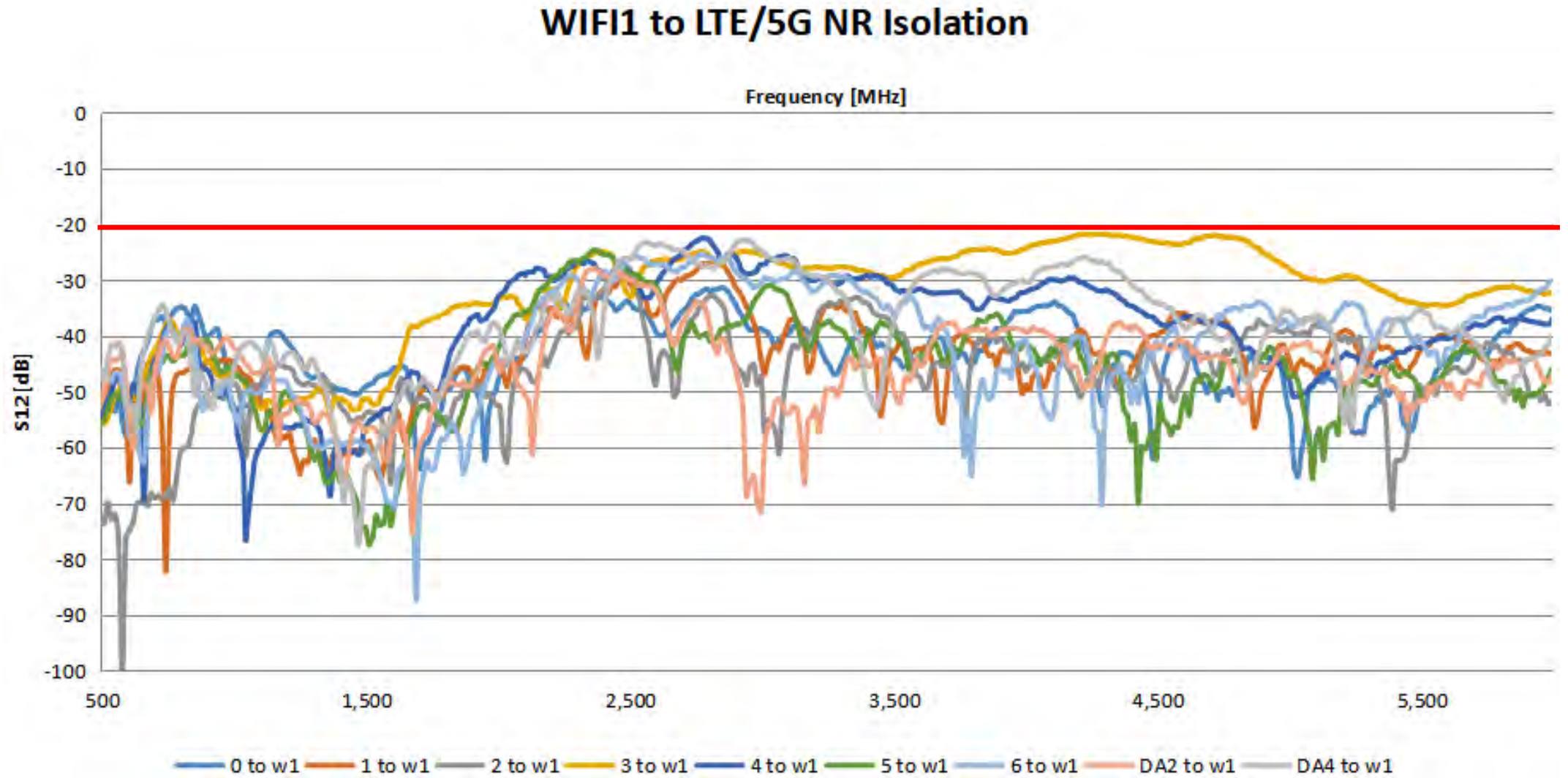



# Isolation – WIFI 2 to LTE/5G NR

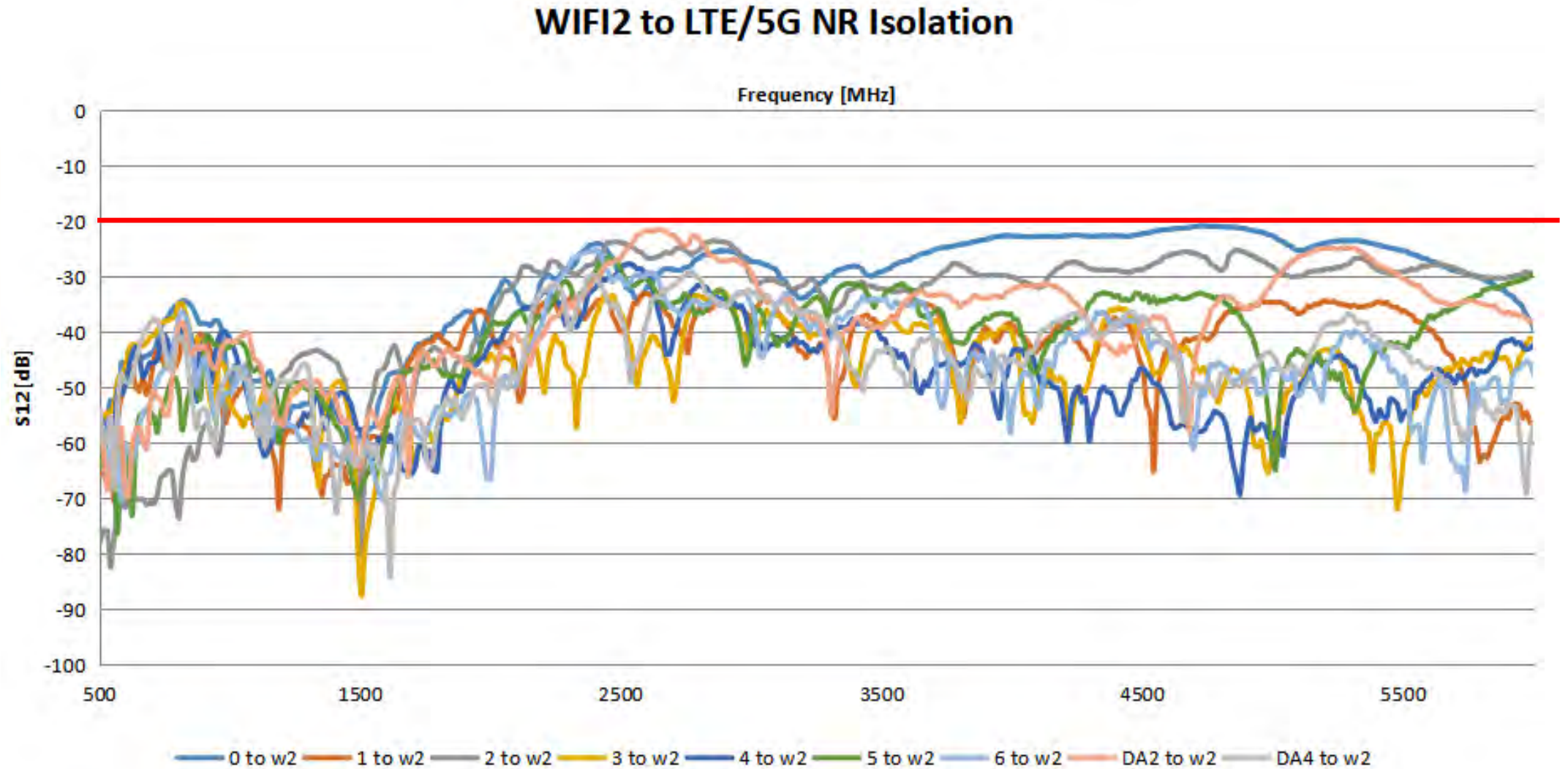

# Isolation – WIFI 3 to LTE/5G NR

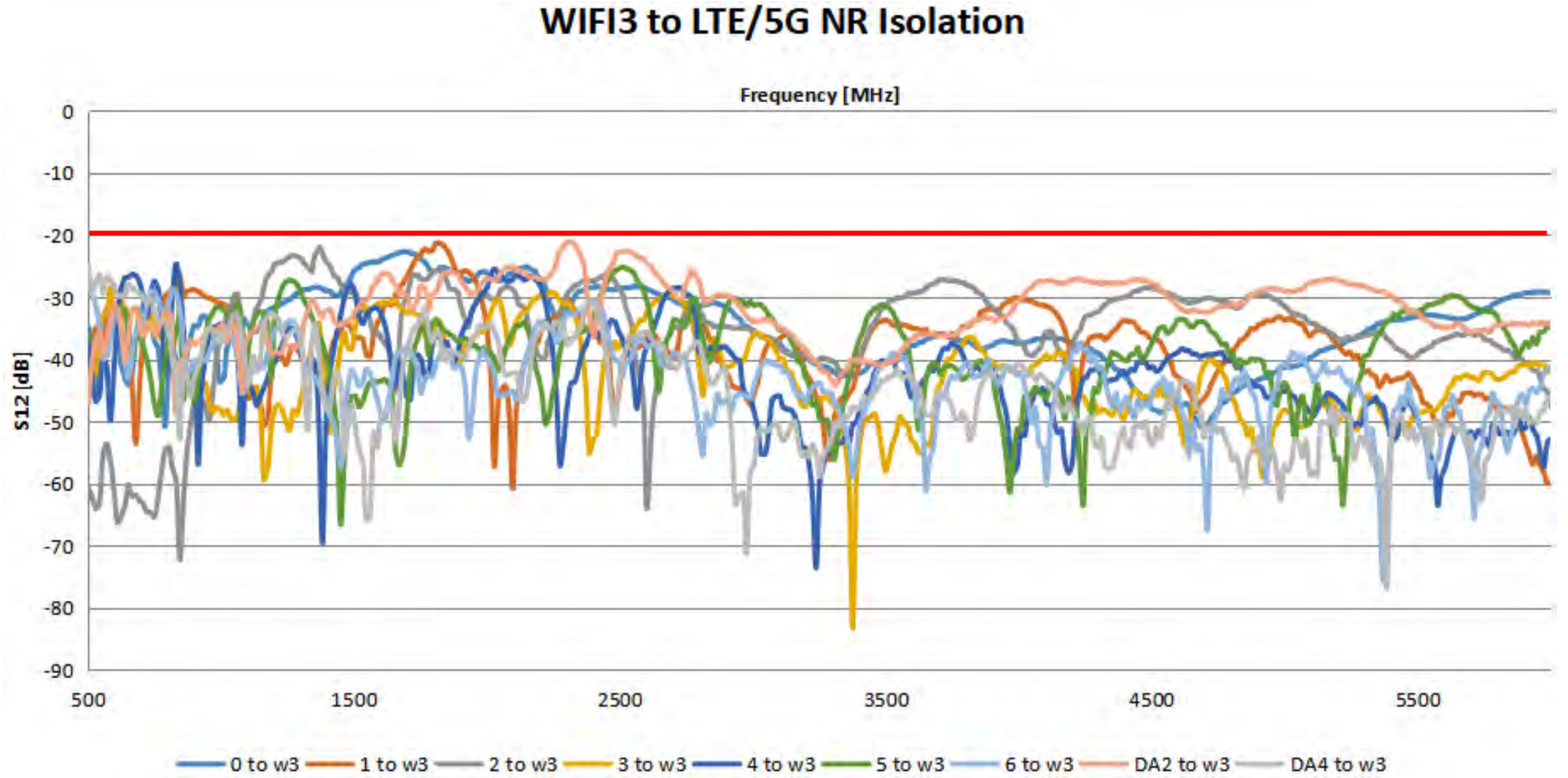



# Isolation – GPS to LTE/5G NR

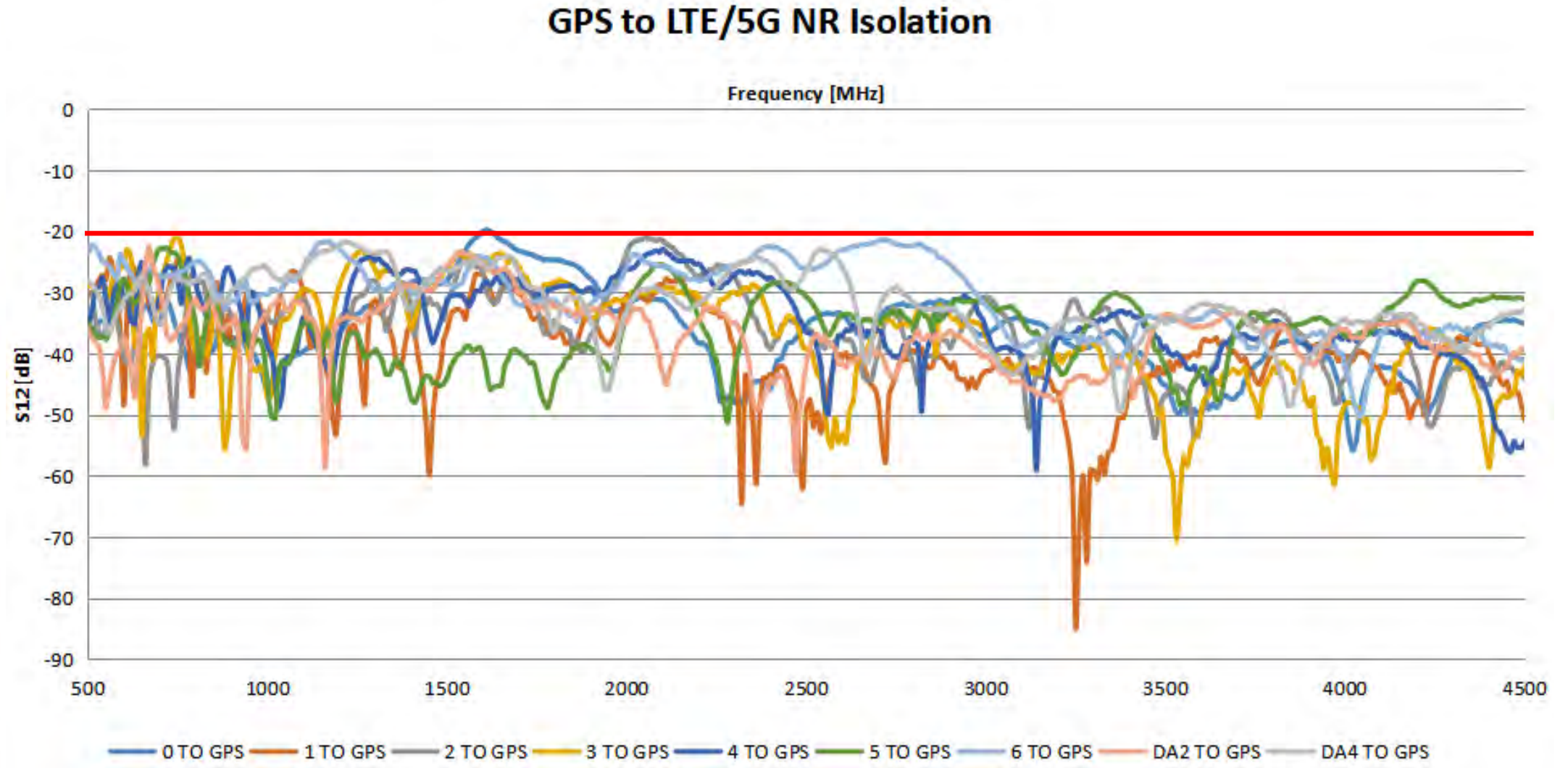

# Isolation – GPS to WIFI

## GPS to WIFI Isolation

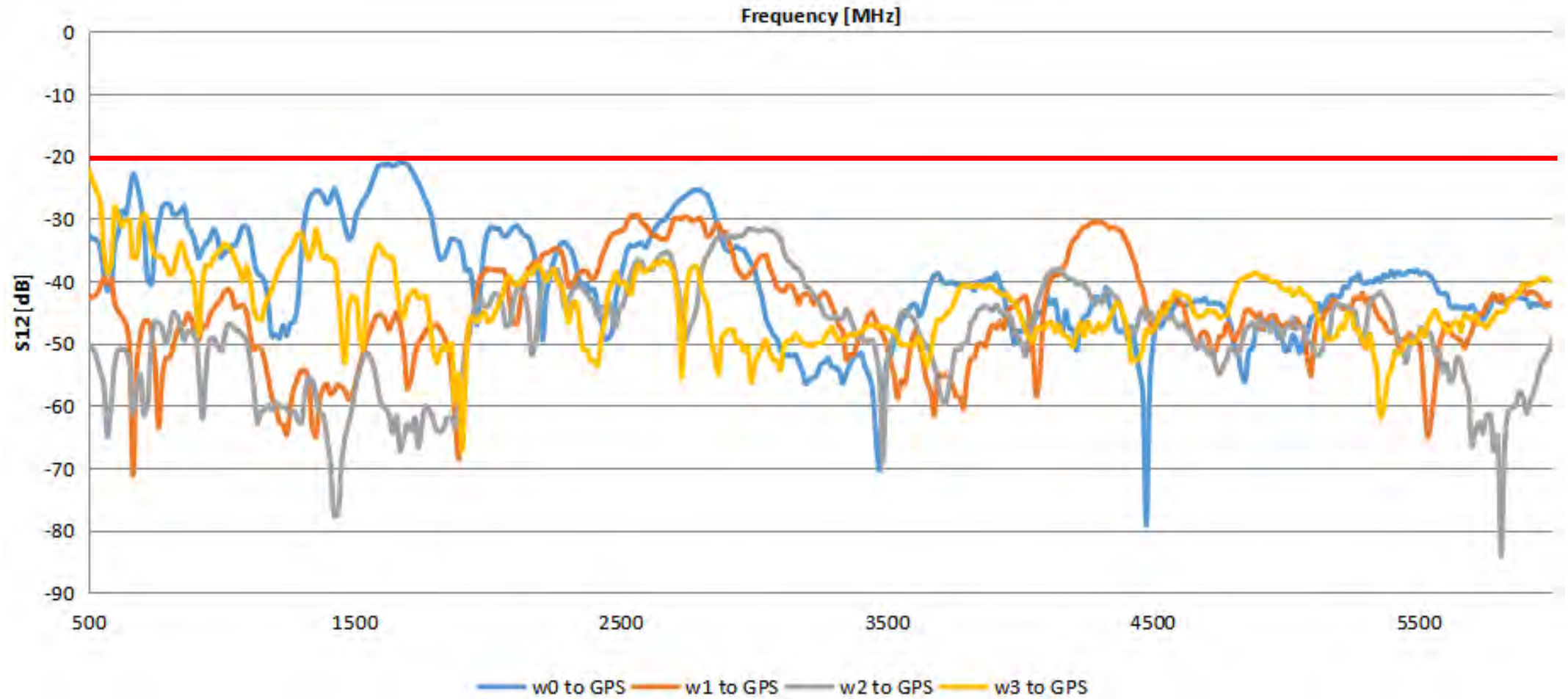



# Isolation – BT to LTE/5G NR

## BT to LTE/5G NR Isolation

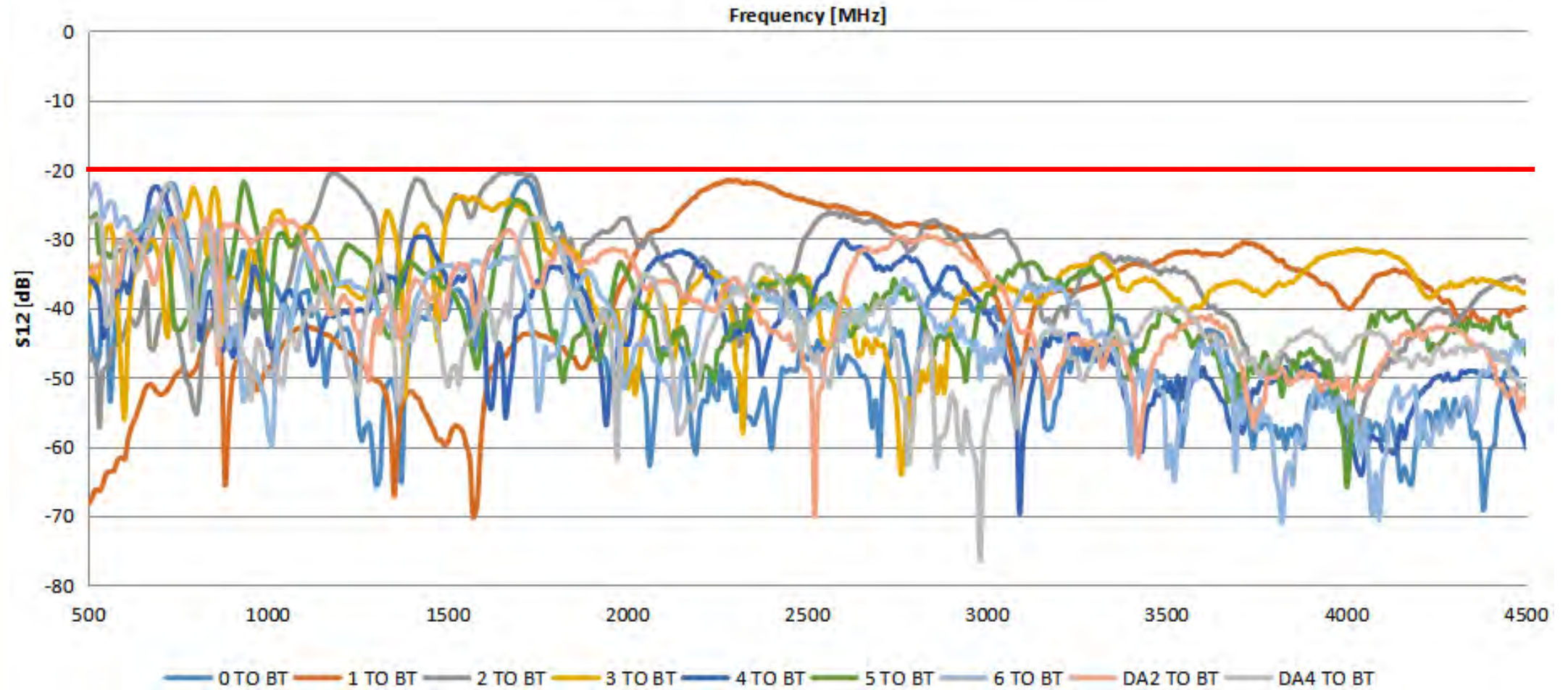

# Isolation – BT to WIFI

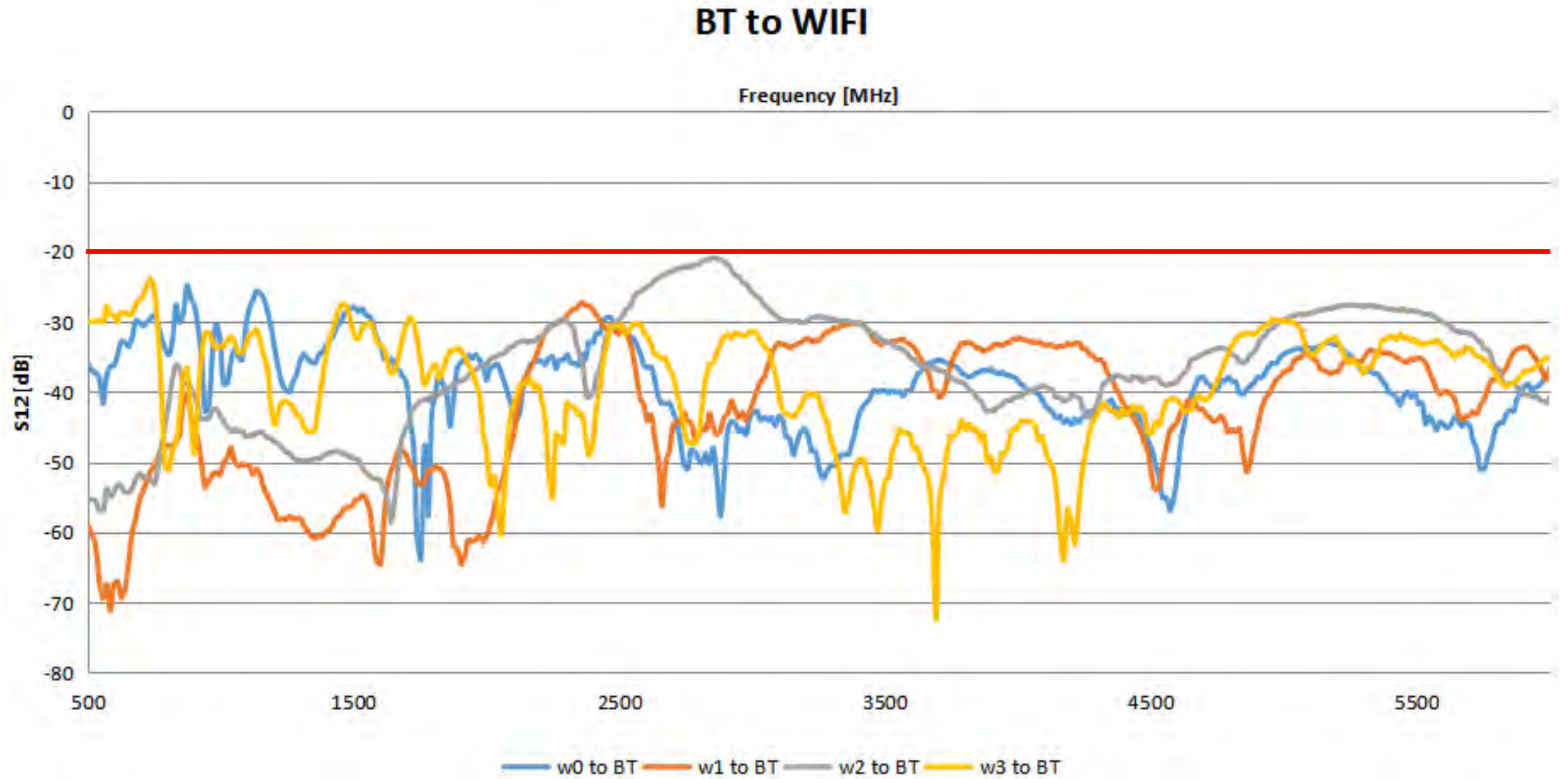



# 2D Radiation Pattern – Ant 0

n71

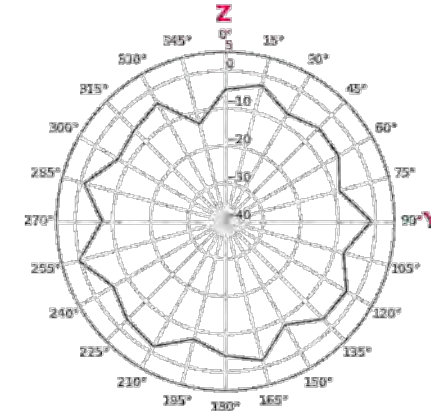
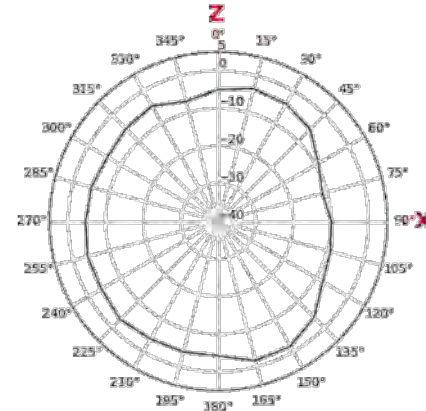
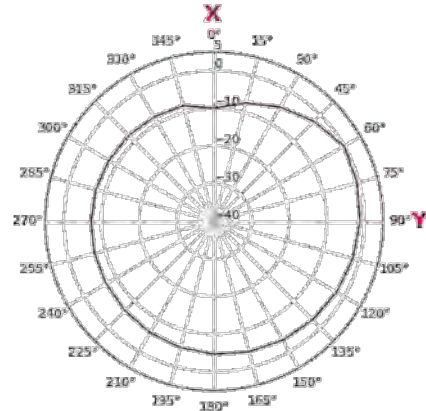

B12

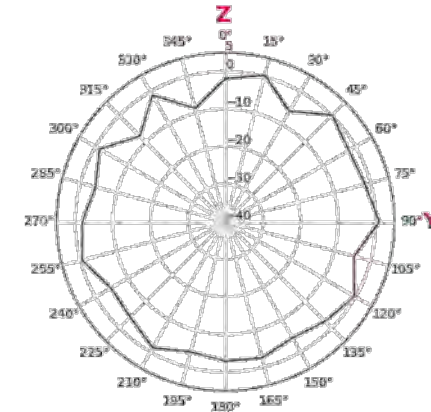
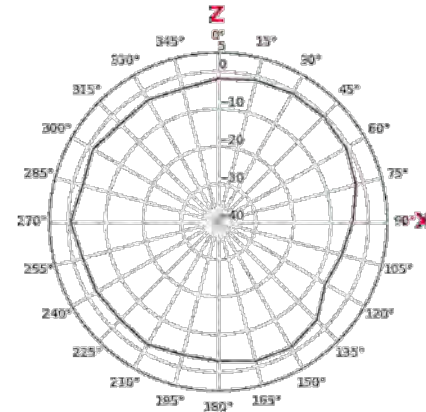
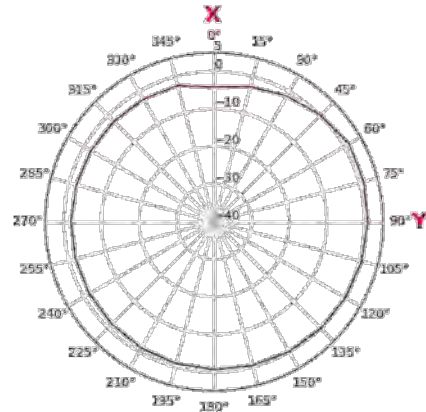

B5

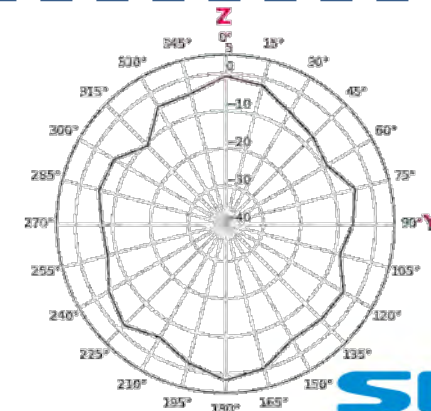
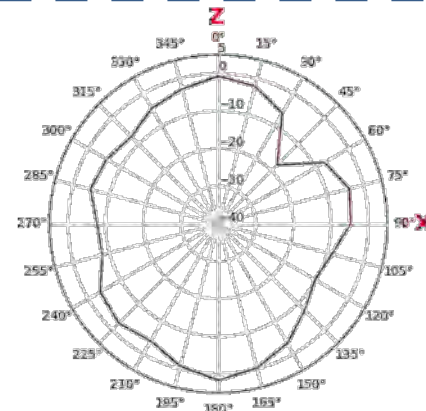
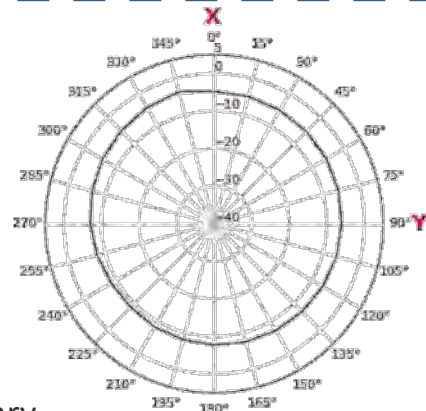

# 2D Radiation Pattern – Ant 1 @LB

n71

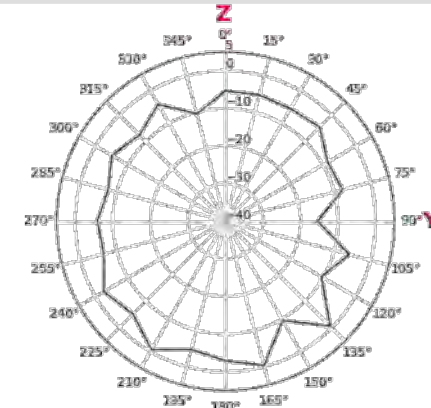
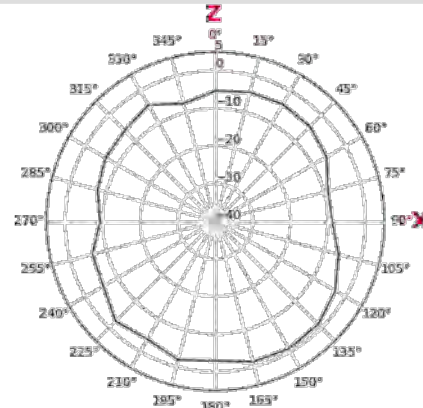
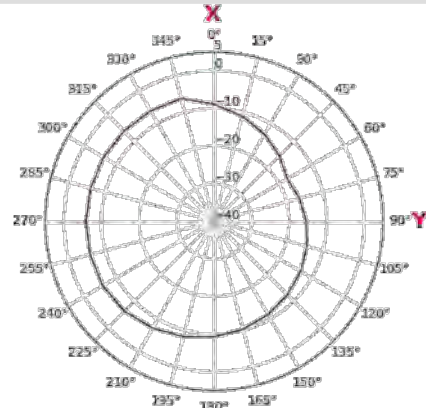

B12

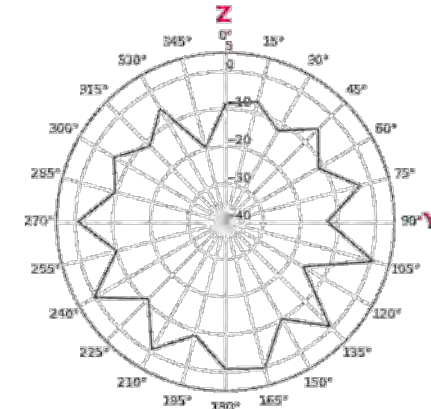
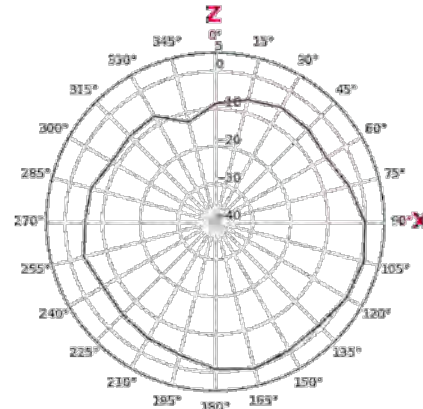
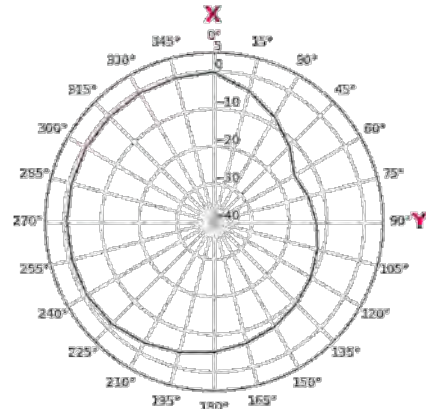

B5

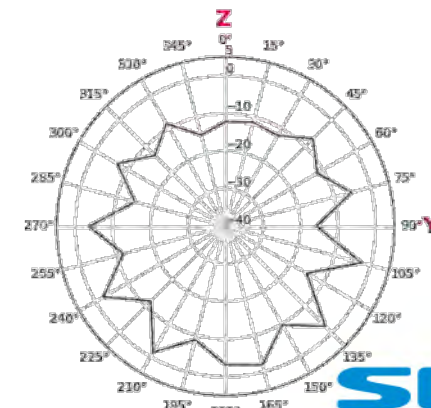
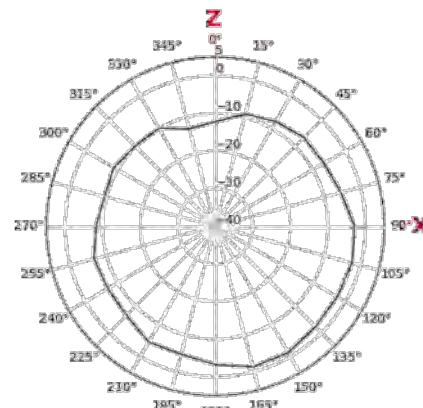
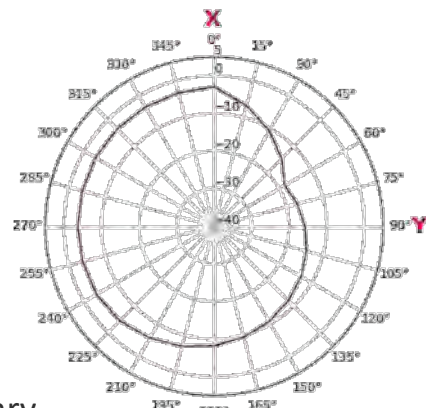



# 2D Radiation Pattern – Ant 1 @MHB

B66

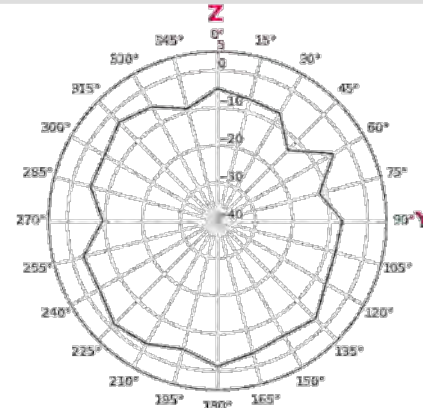
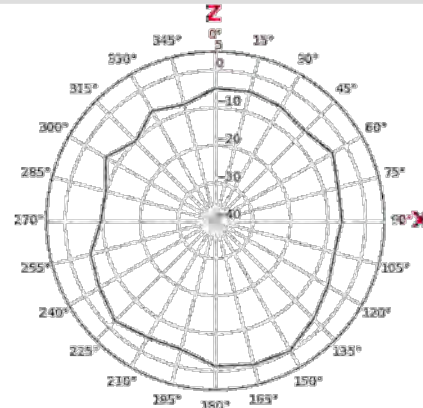
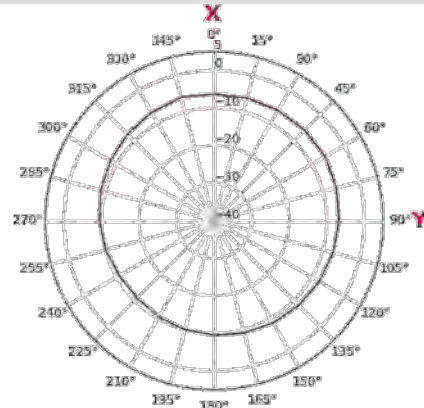

B2/25

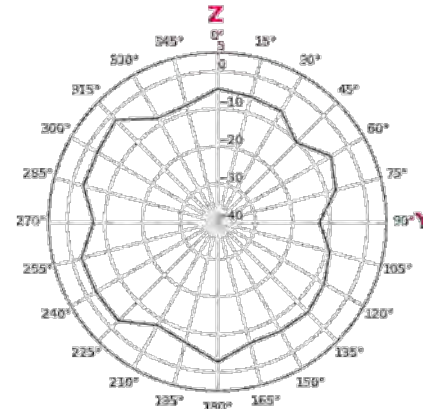
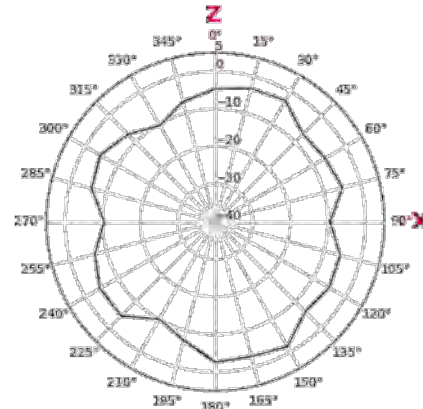
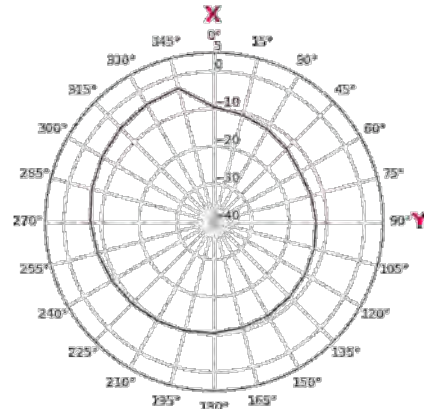

n41

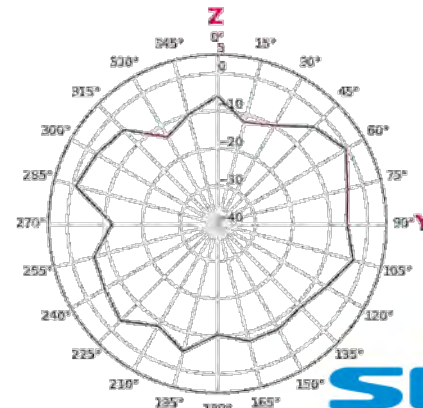
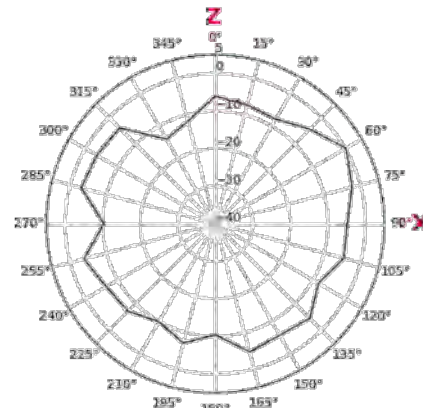
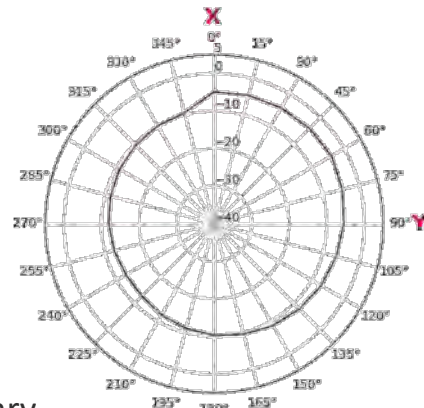



# 2D Radiation Pattern – Ant 2 @MHB

B66

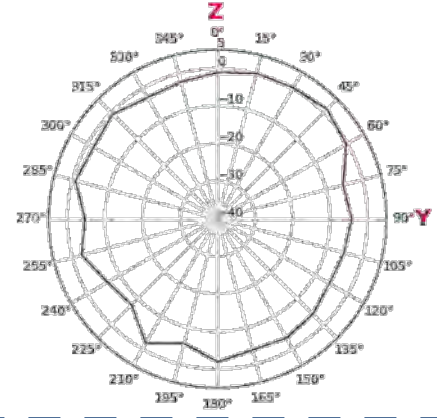
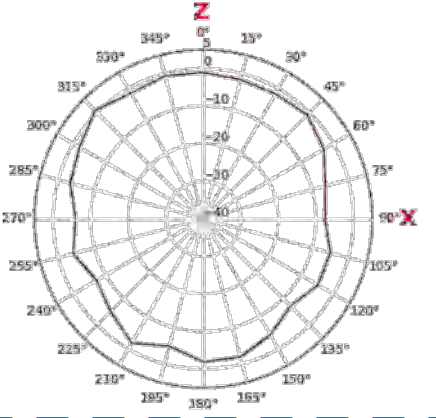
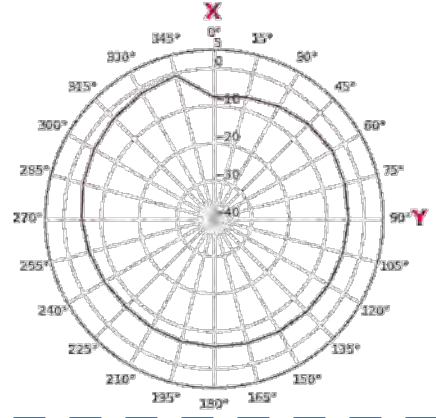

B2/25

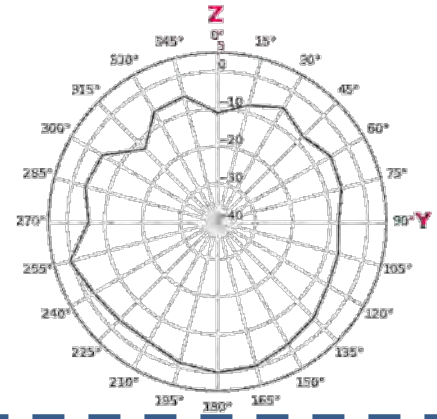
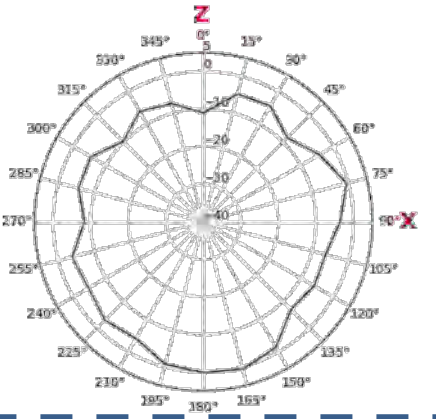
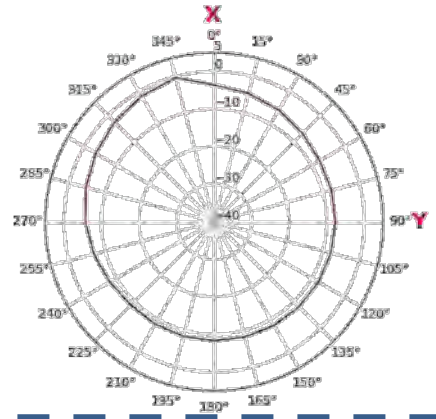

n41

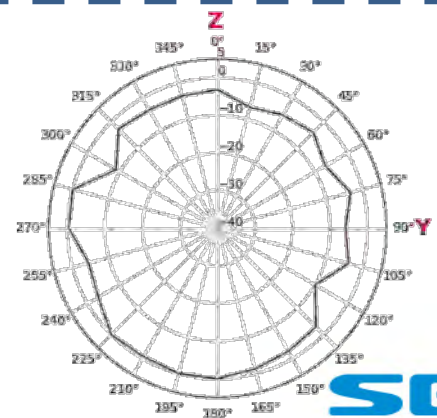
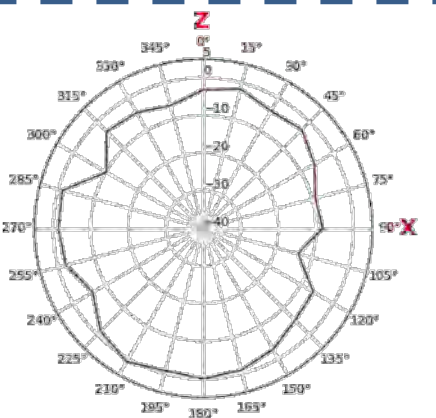
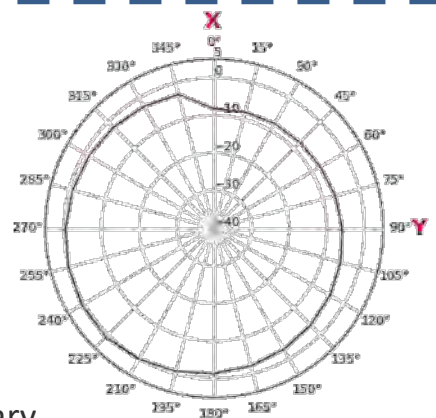

# 2D Radiation Pattern – Ant 2 @UHB

n77/B48

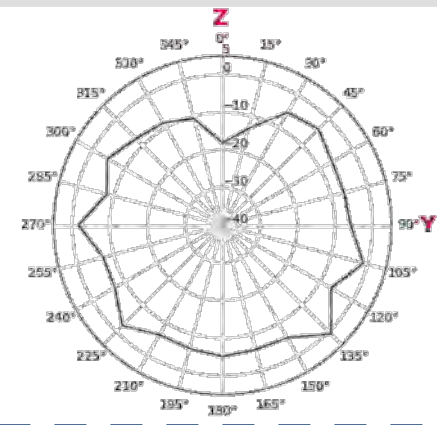
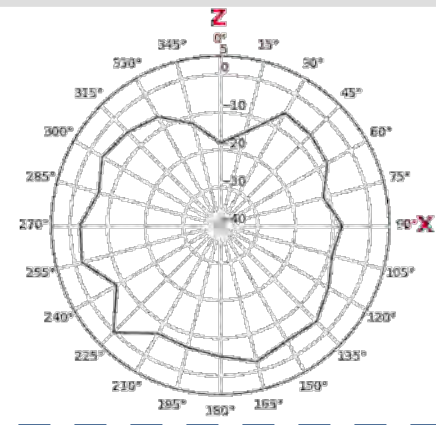
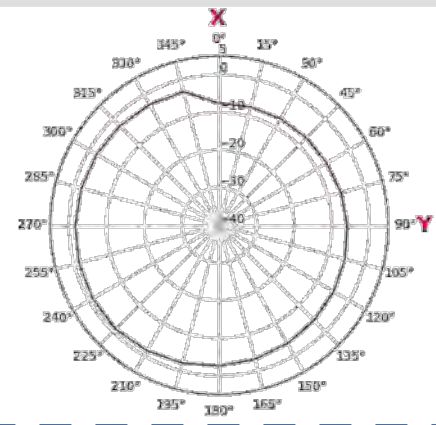

# 2D Radiation Pattern – Ant 3 @LB

n71

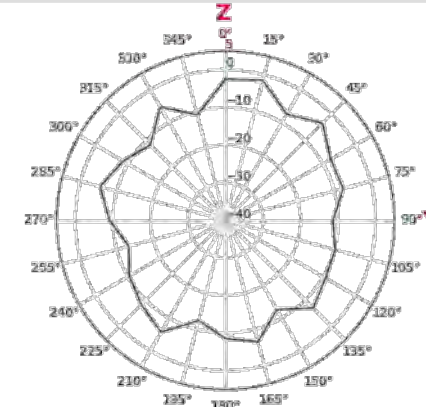
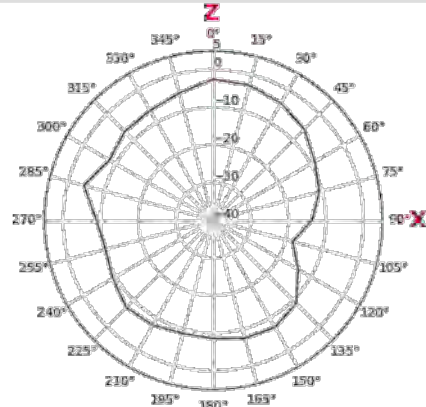
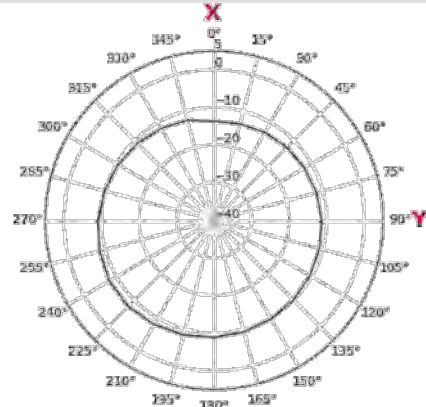

B12

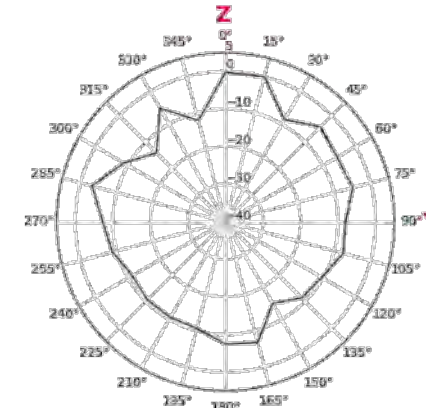
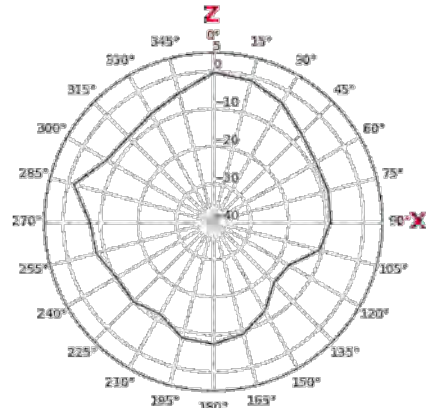
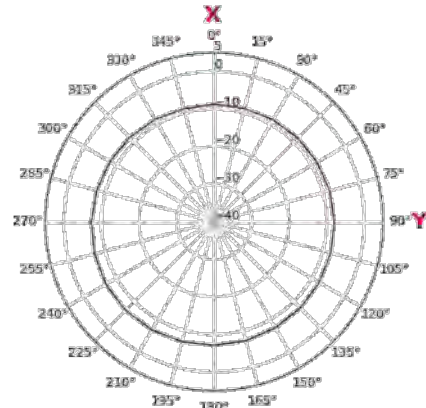

B5

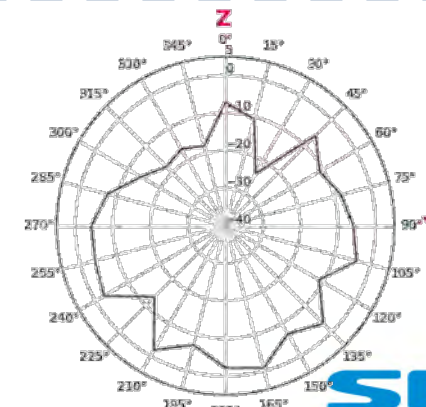
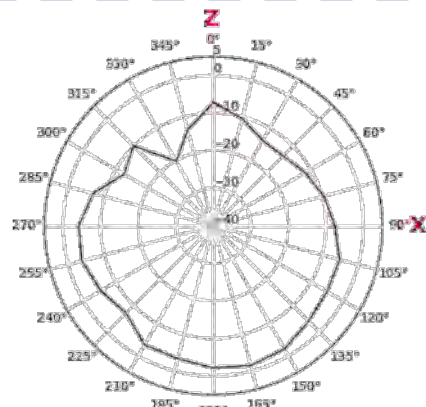
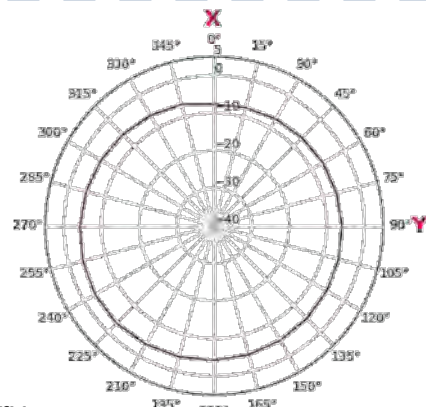



# 2D Radiation Pattern – Ant 3 @MHB

B66

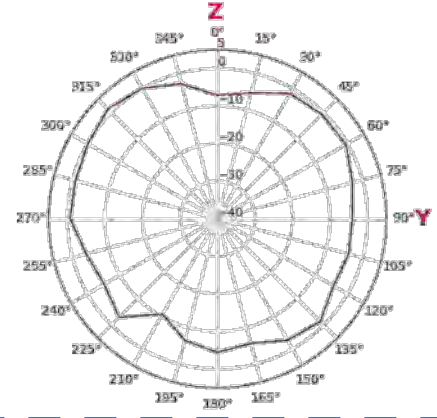
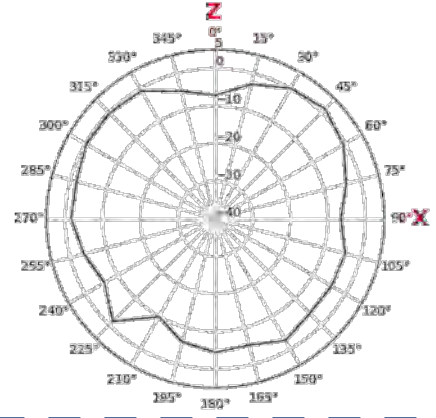
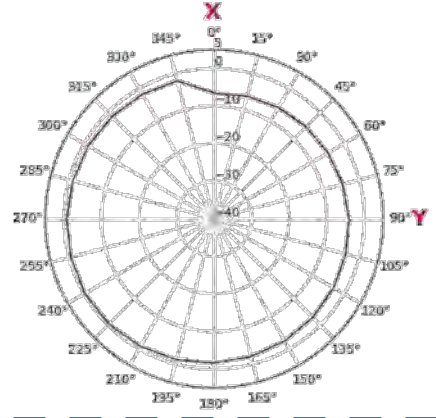

B2/25

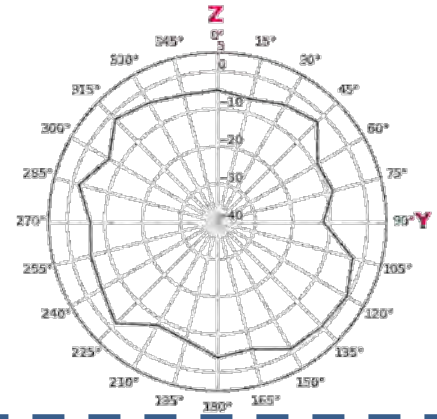
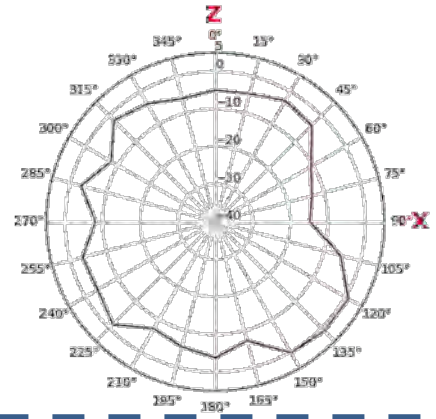
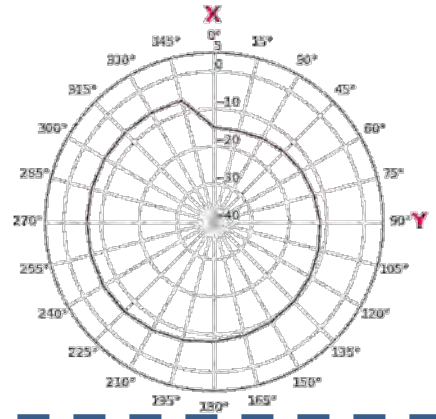

n41

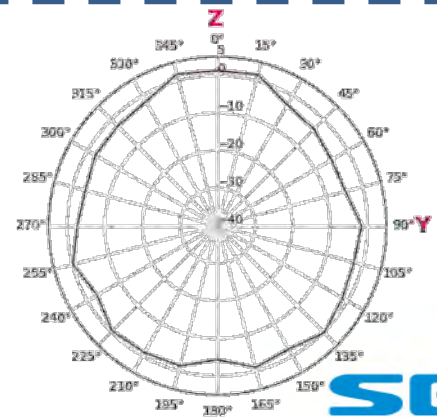
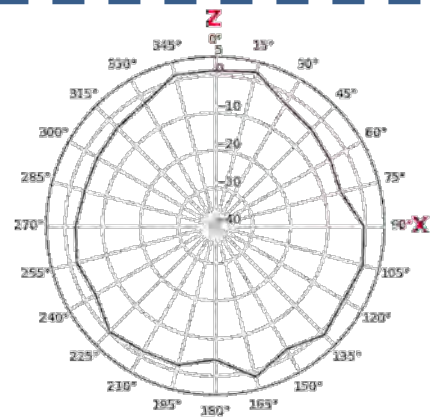
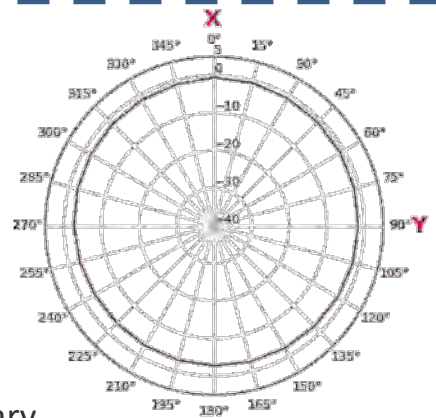

# 2D Radiation Pattern – Ant 4 @LB

n71

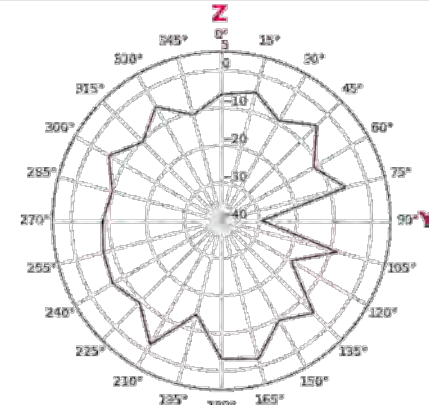
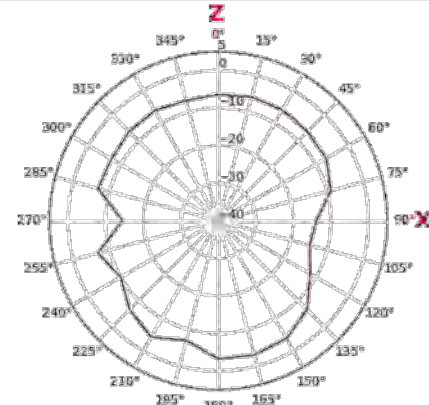
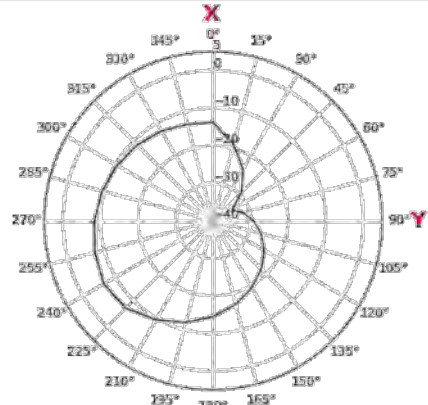

B12

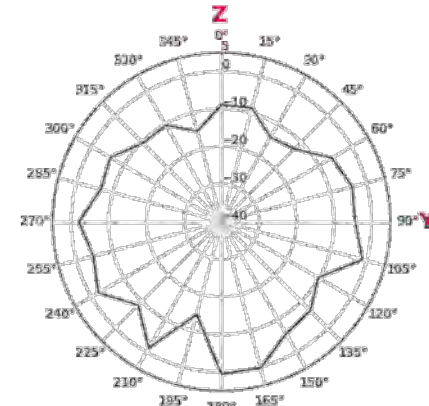
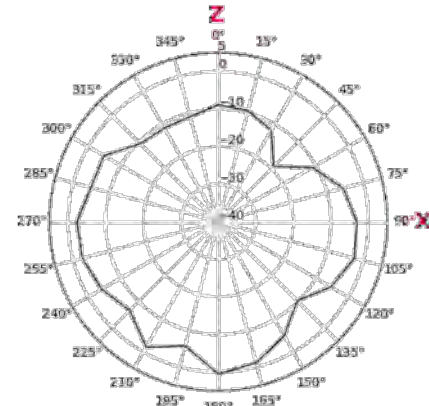
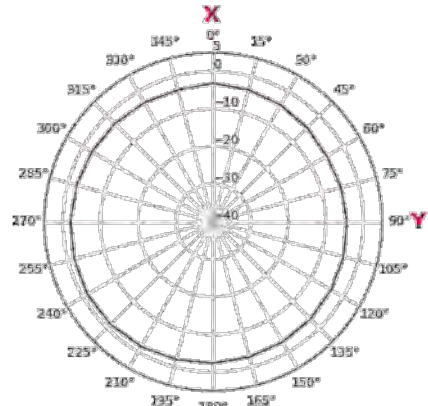

B5

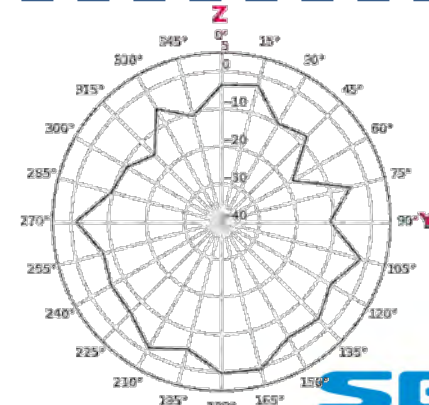
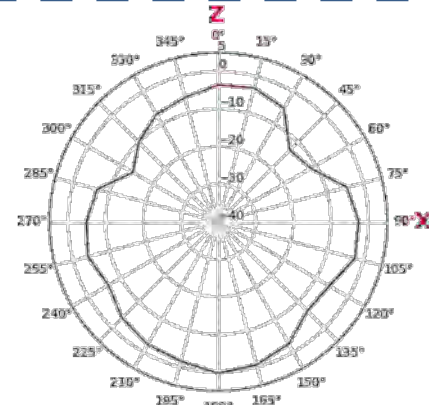
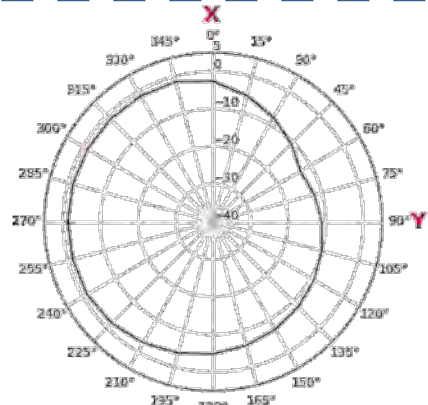



# 2D Radiation Pattern – Ant 4 @MHB

B66

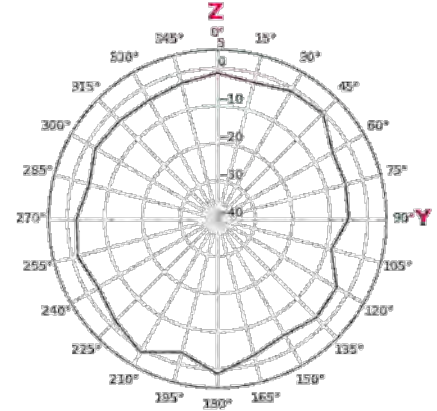
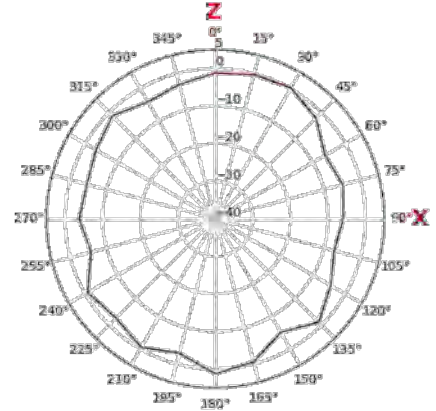
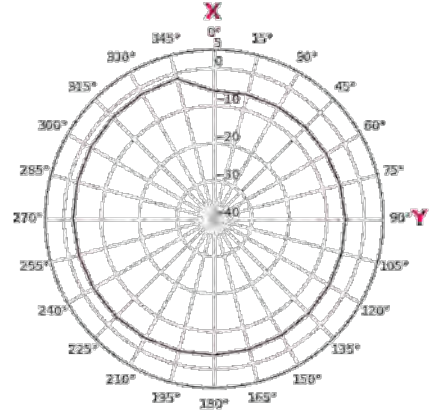

B2/25

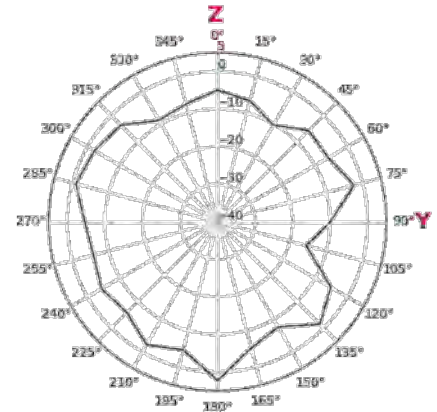
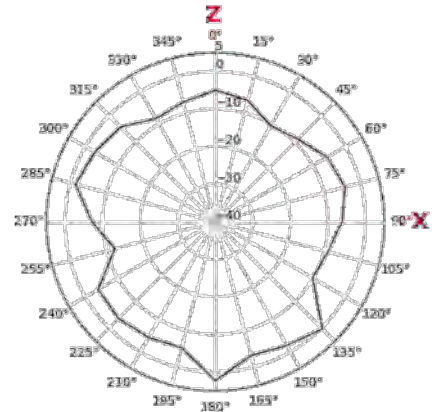
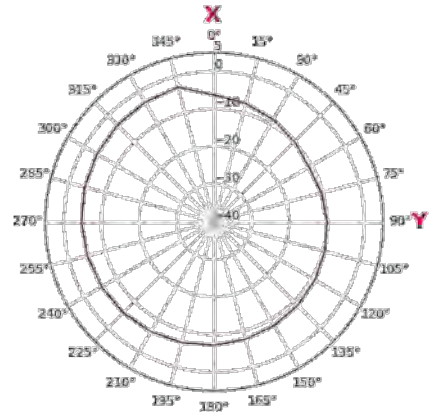

n41

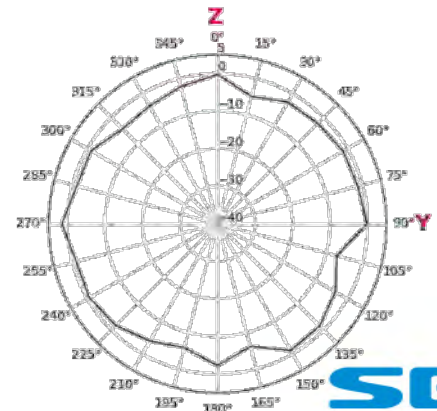
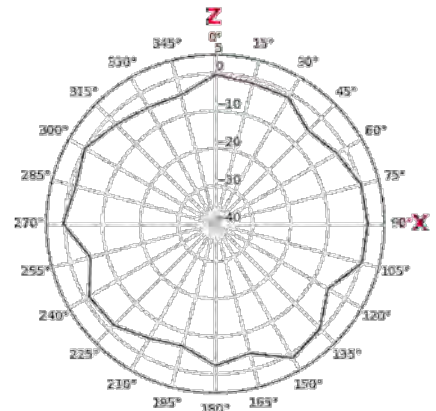
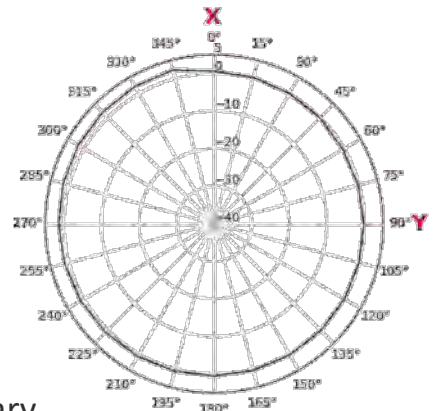

# 2D Radiation Pattern – Ant 4 @UHB

n77/B48

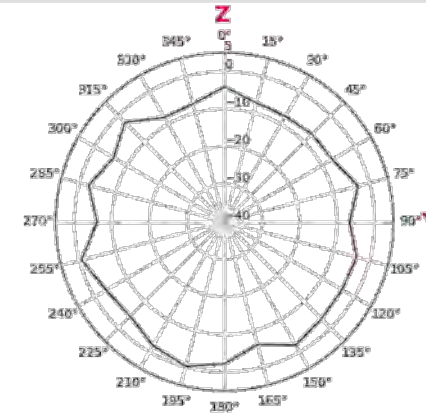
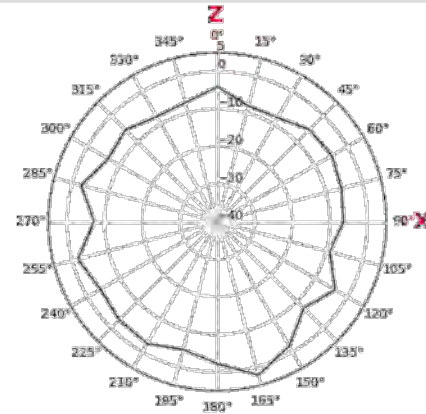
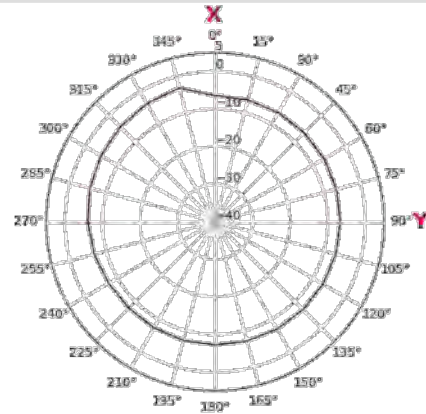

# 2D Radiation Pattern – Ant 5/6 @UHB

n77/B48

Ant 5

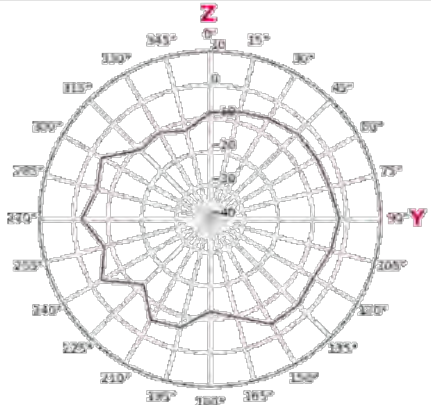
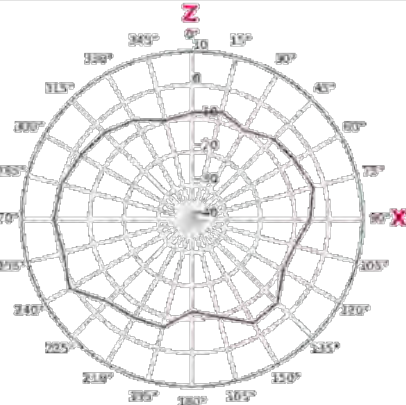
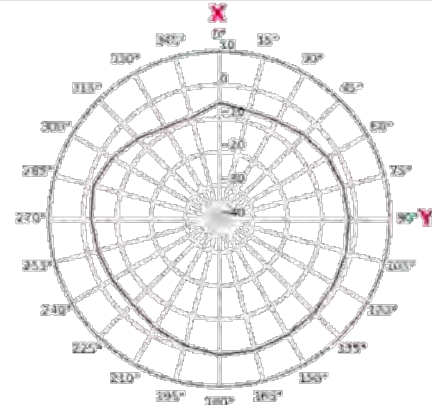

n77/B48

Ant 6

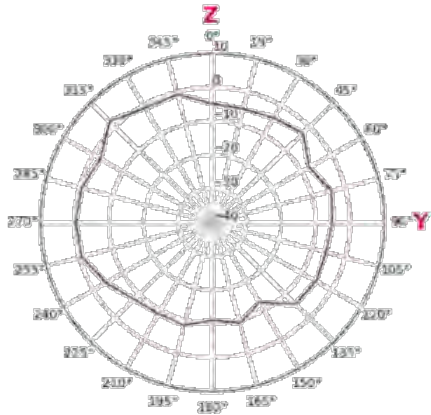
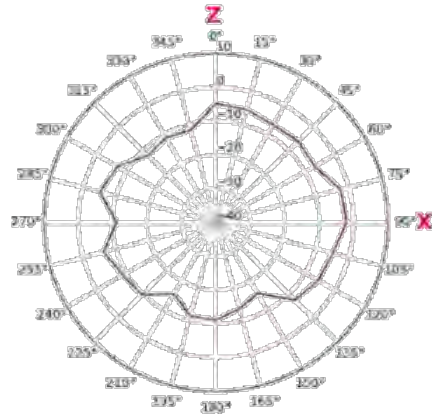
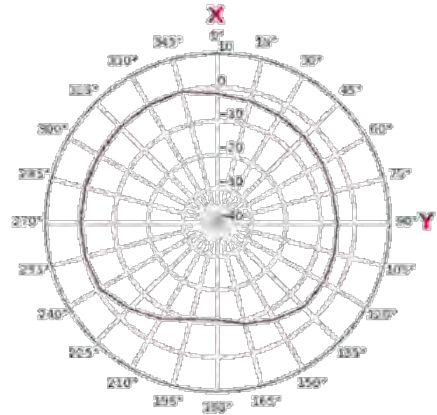



# 2D Radiation Pattern – DA2 @MHB

B66

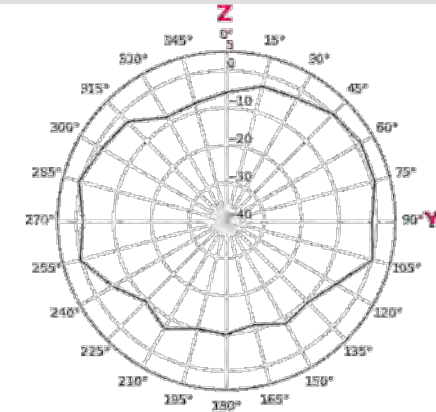
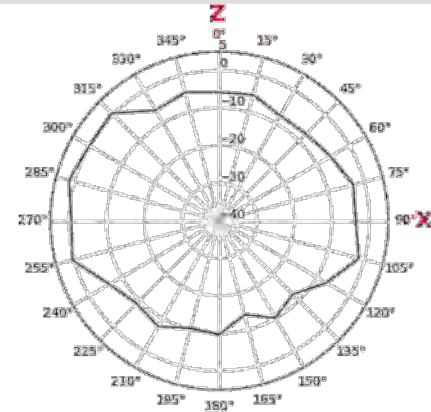
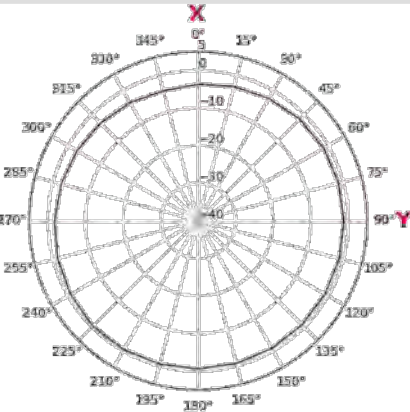

B2/25

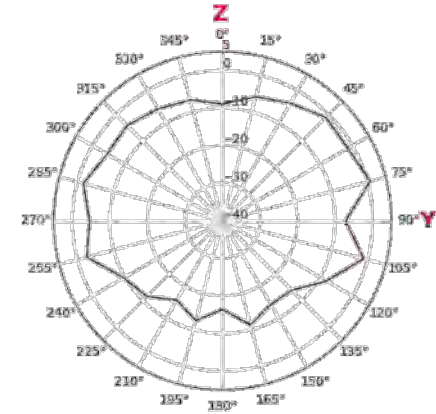
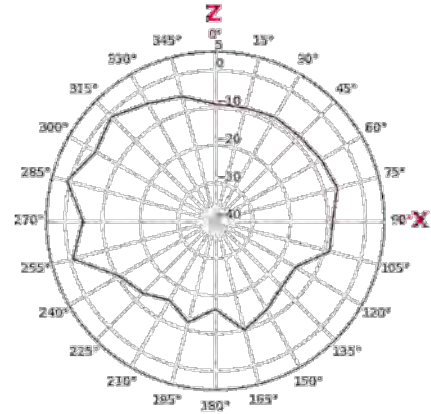
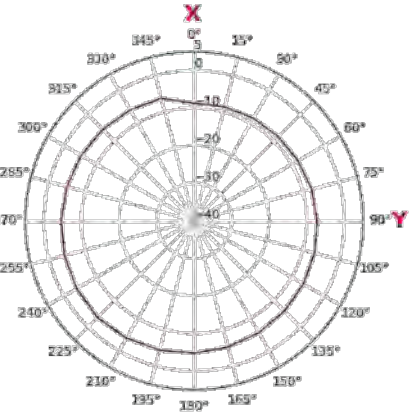

n41

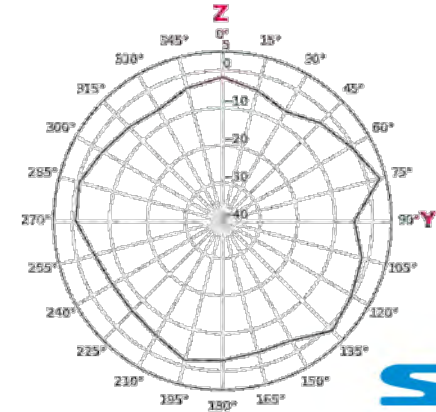
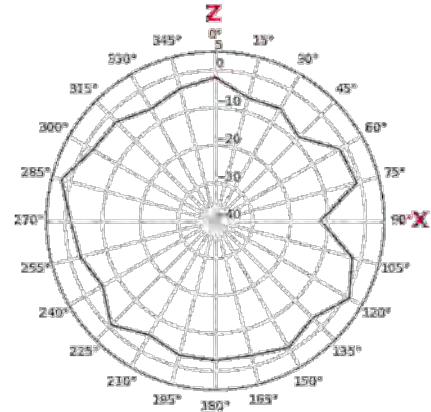
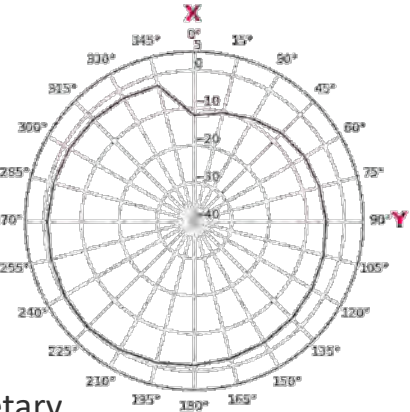

# 2D Radiation Pattern – DA2 @UHB

n77/B48

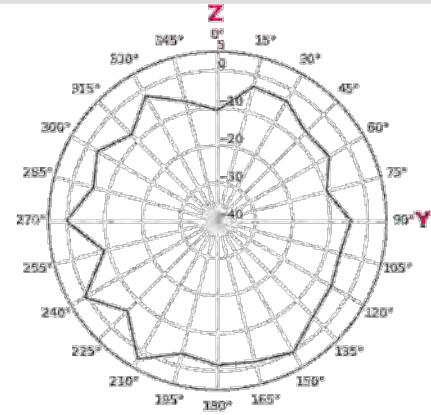
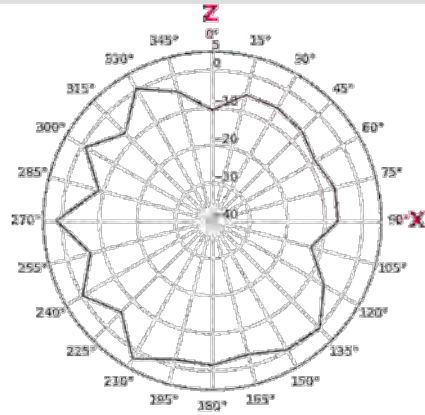
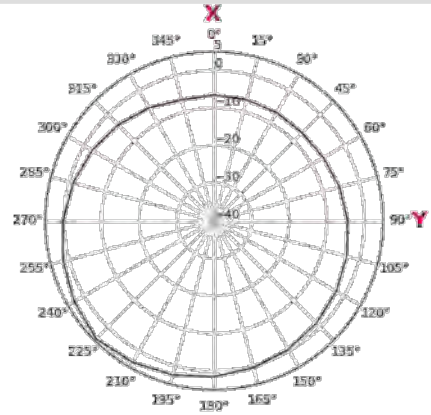



# 2D Radiation Pattern – DA4 @LB

n71

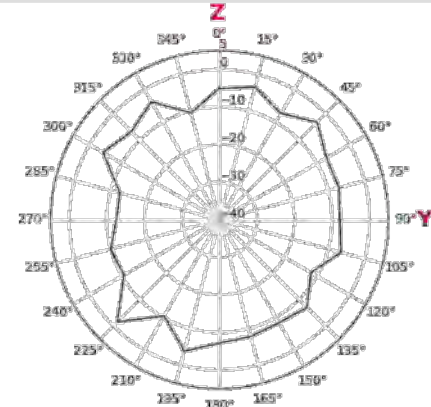
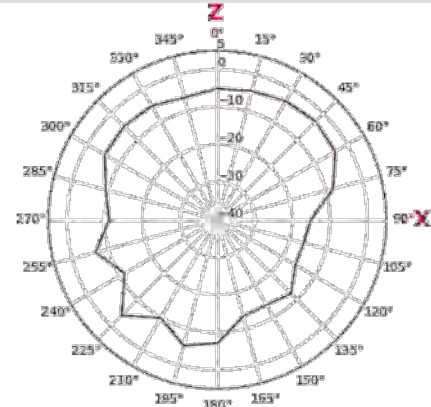
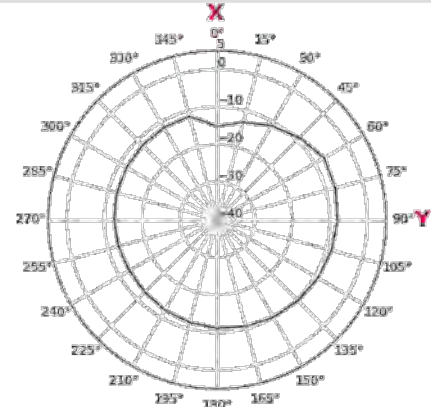

B12

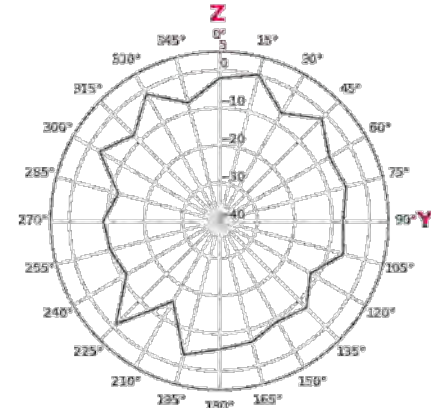
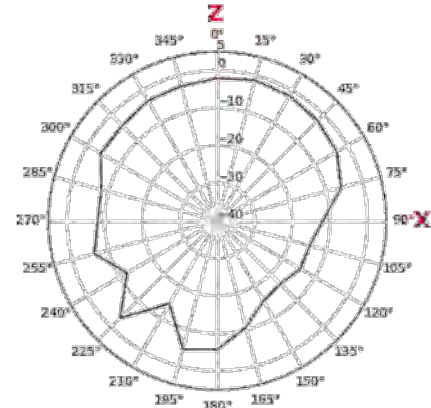
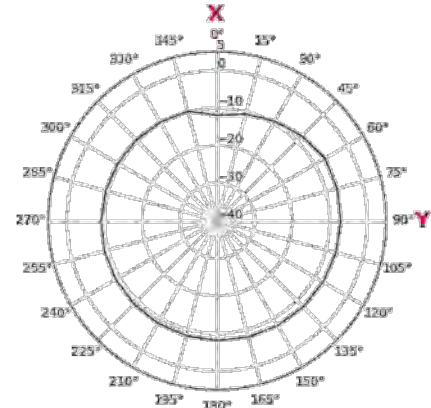

B5

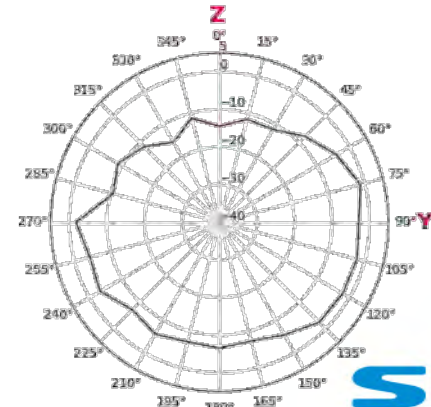
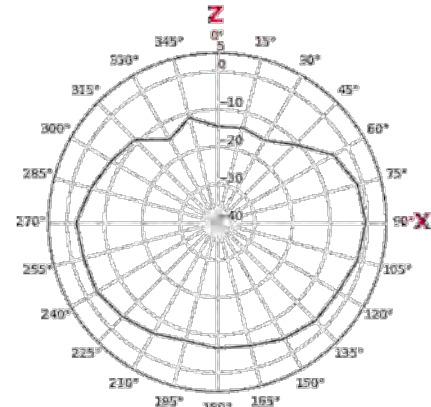
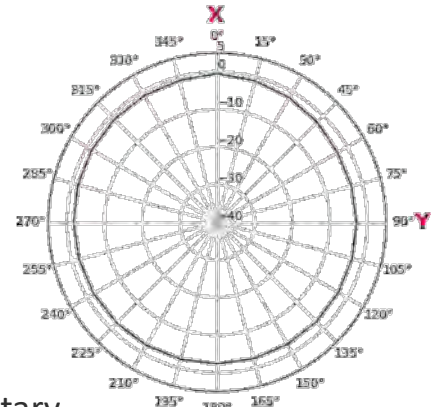

# 2D Radiation Pattern – DA4 @MHB

B66

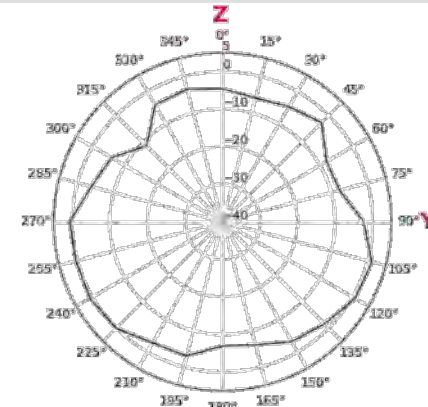
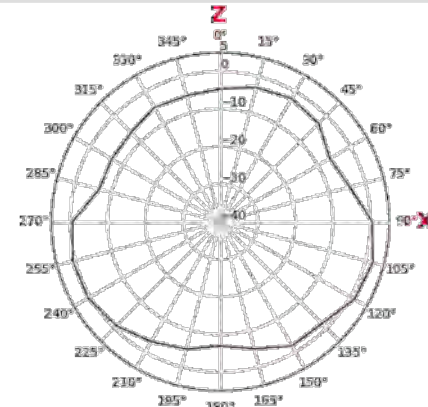
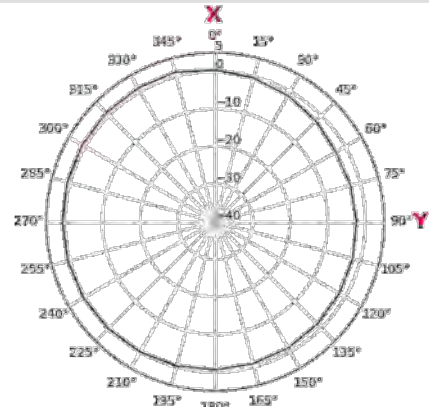

B2/25

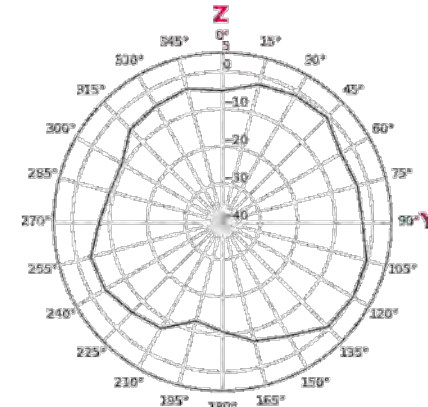
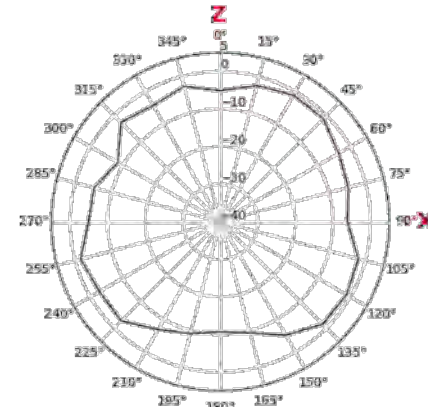
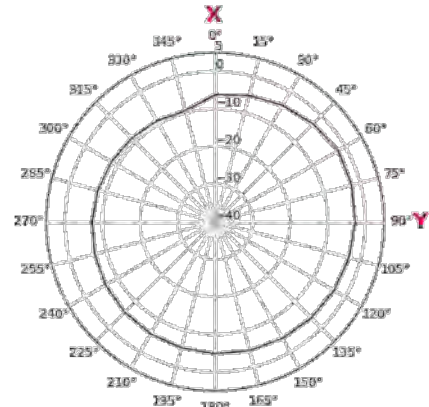

n41

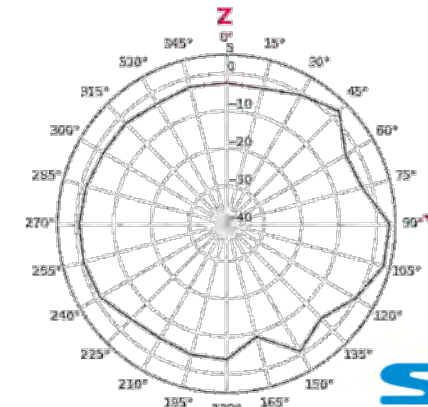
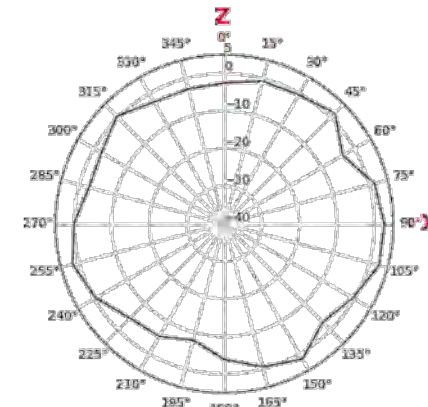
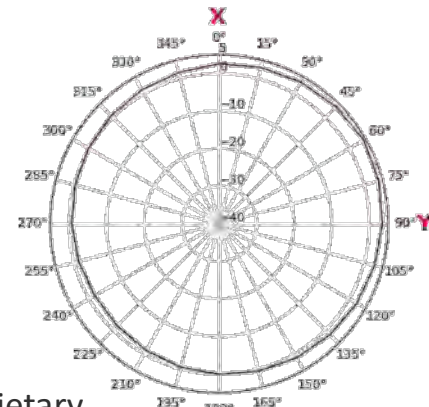

# 2D Radiation Pattern – DA4 @UHB

n77/B48

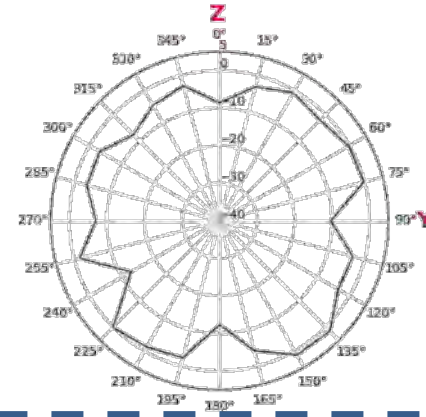
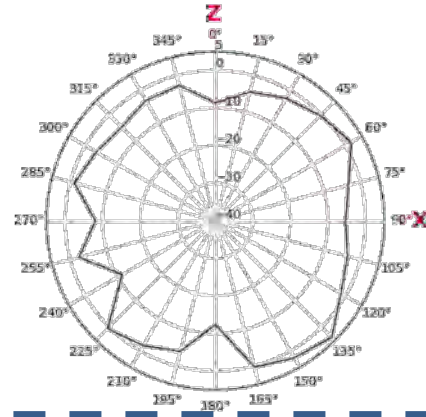
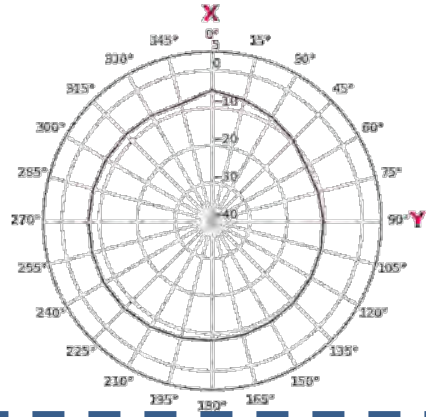



# 2D Radiation Pattern – WFO

2G

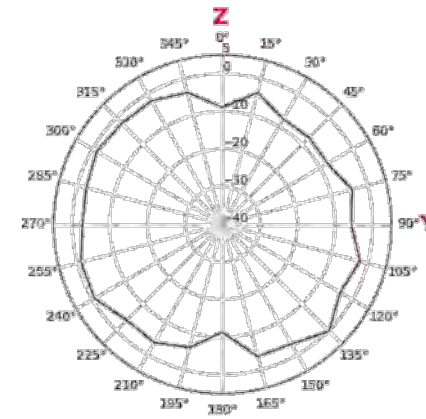
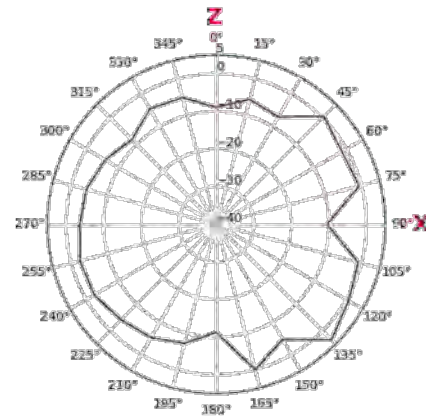
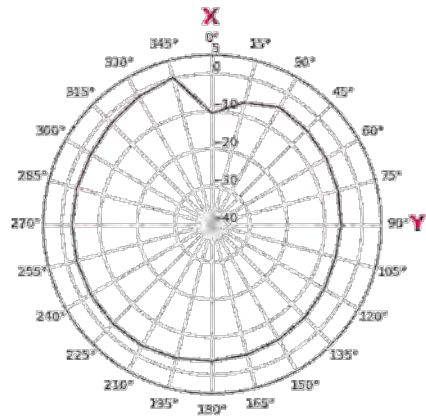

5G

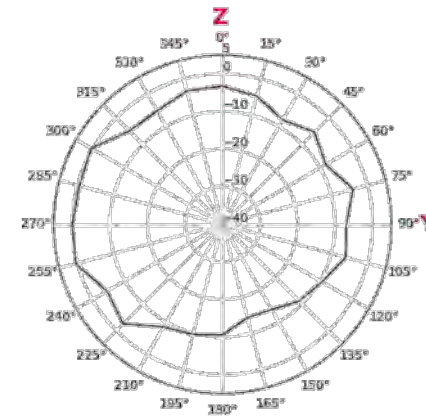
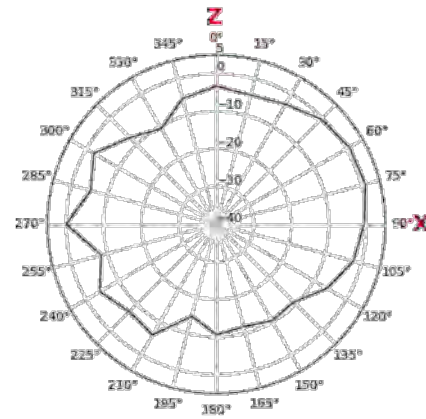
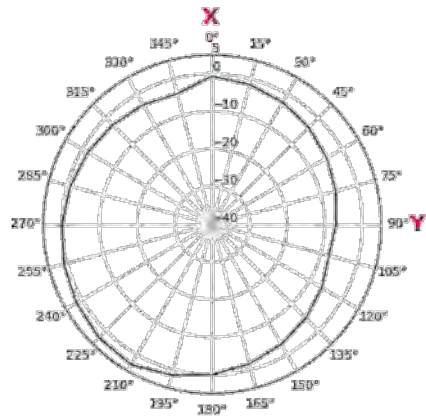



# 2D Radiation Pattern – WF1

2G

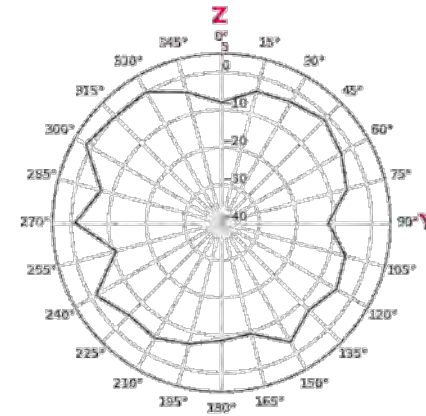
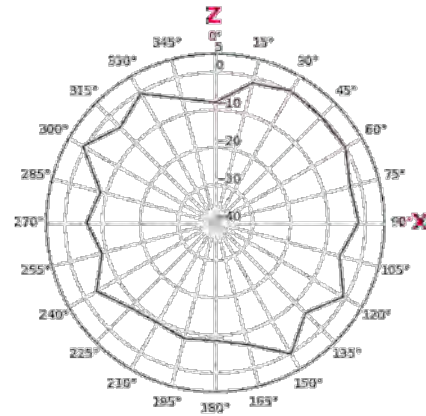
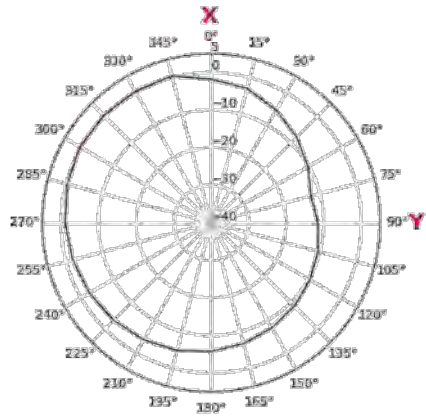

5G

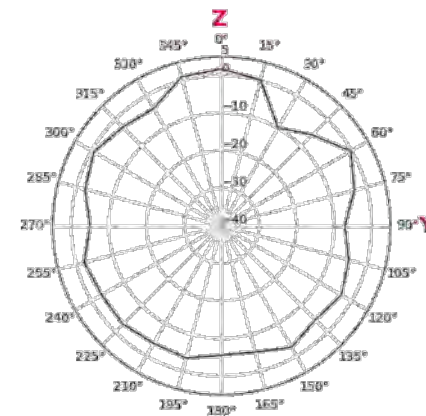
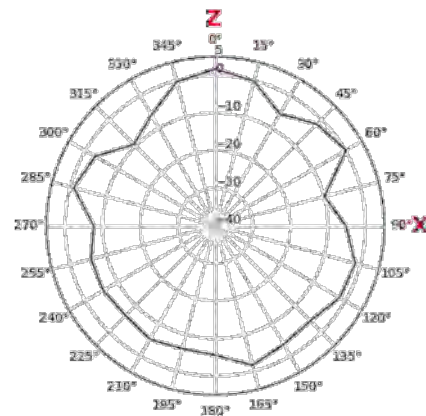
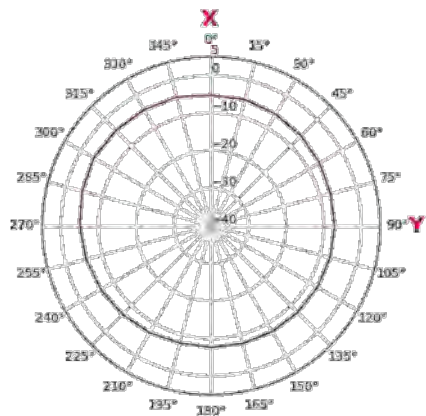

# 2D Radiation Pattern – WF2

2G

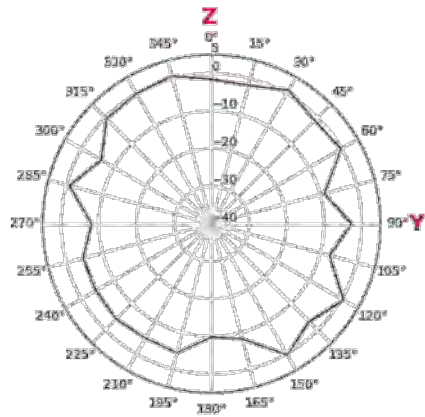
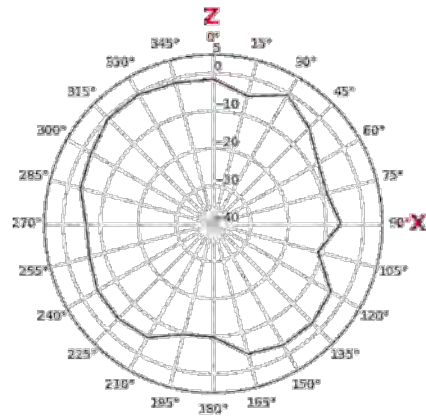
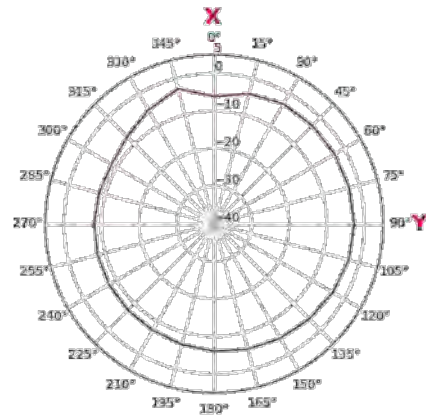

5G

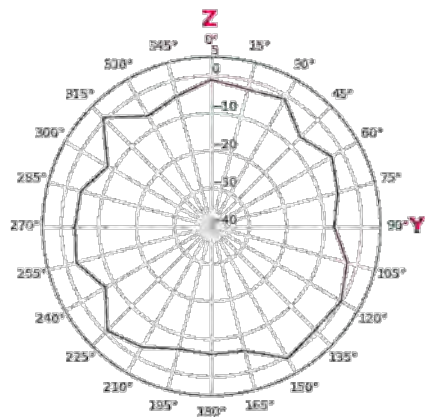
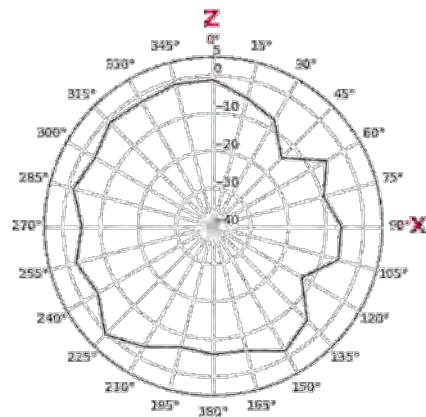
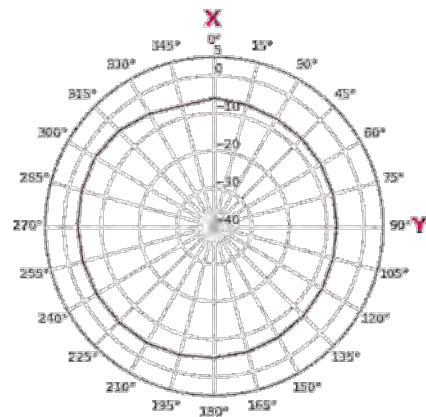

# 2D Radiation Pattern – WF3

2G

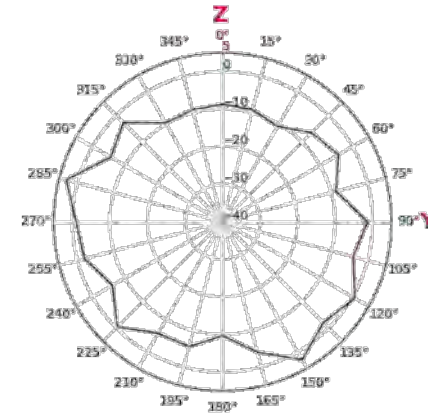
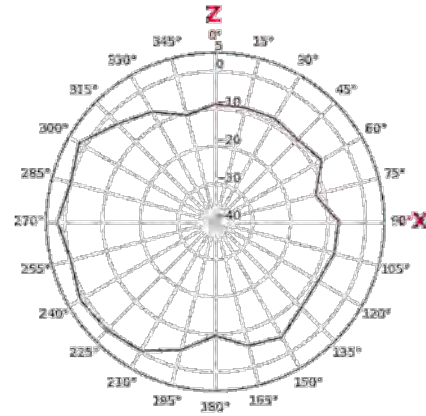
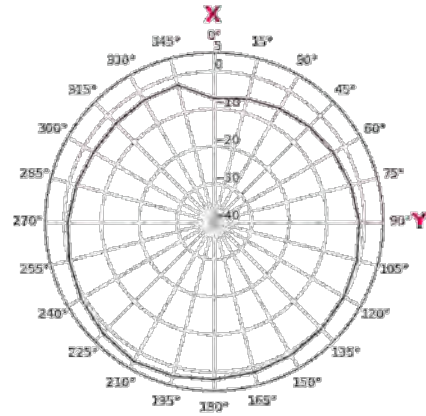

5G

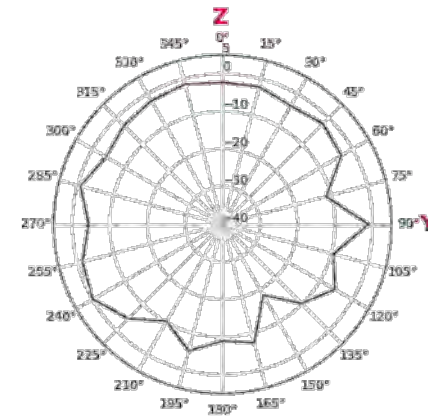
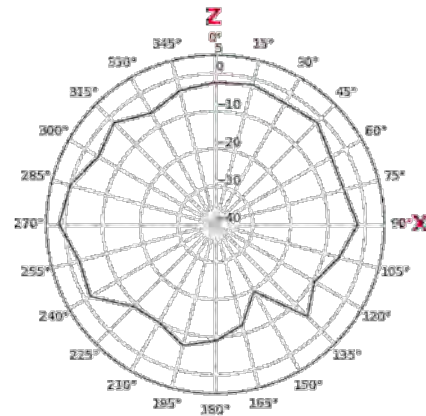
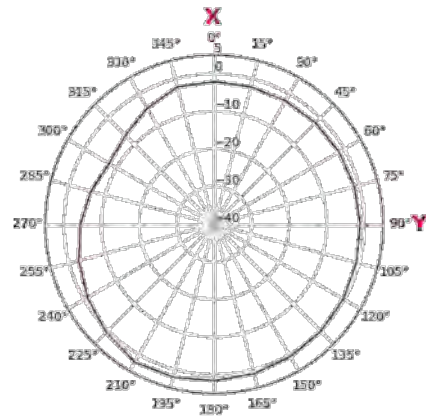

# 3D Radiation Pattern – GPS & BT

## GPS

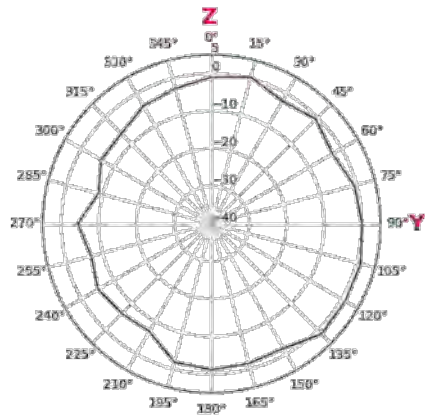
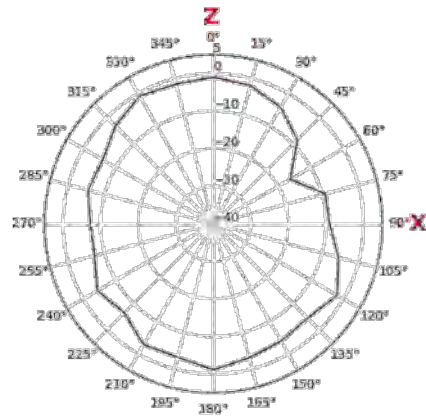
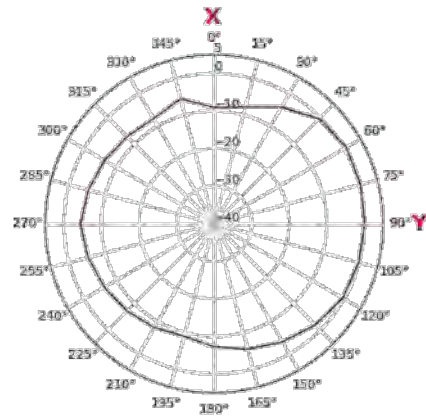

---

## BT



# 3D Radiation Pattern – Ant 0

n71

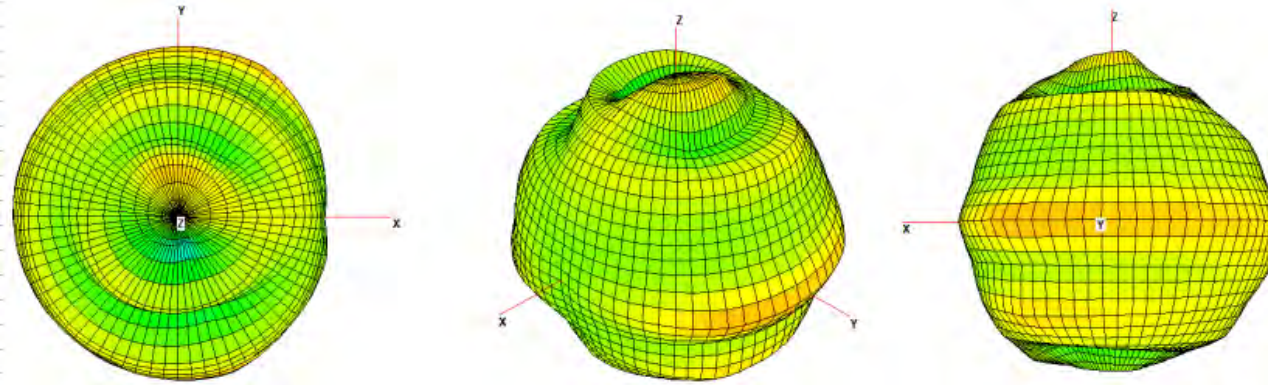

B12

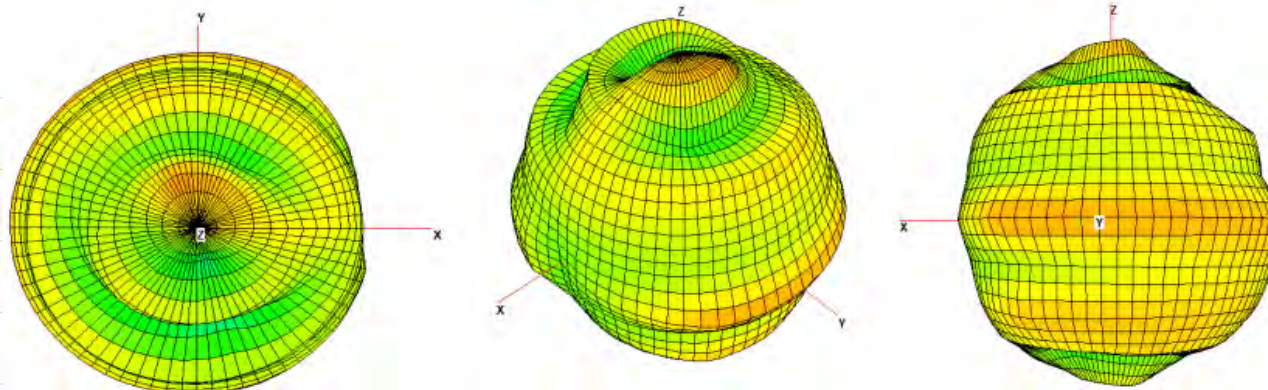

B5

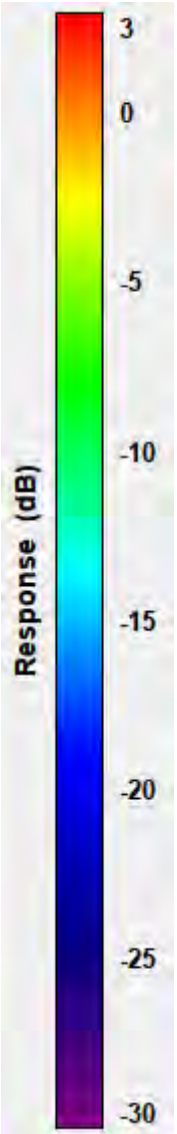
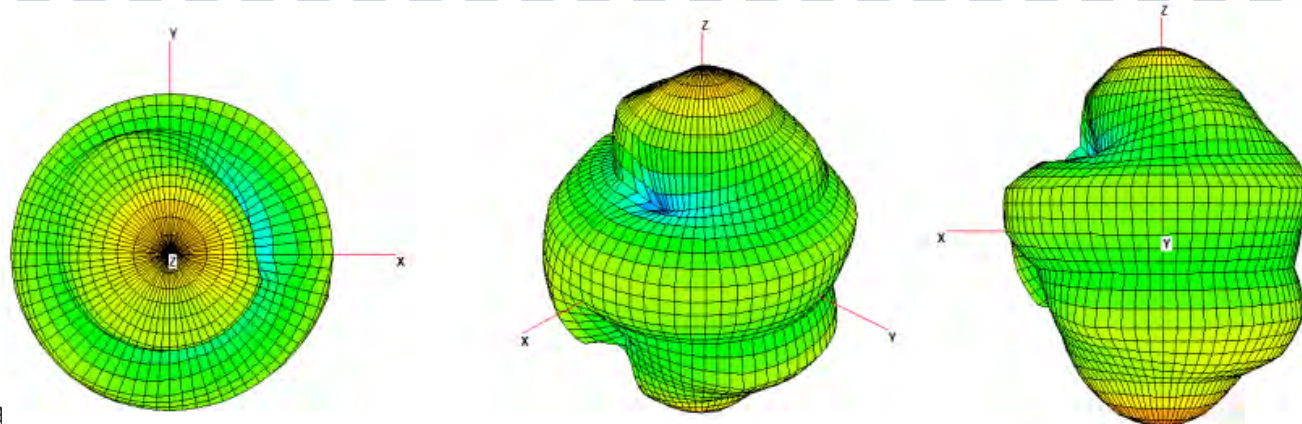



# 3D Radiation Pattern – Ant 1 @LB

n71

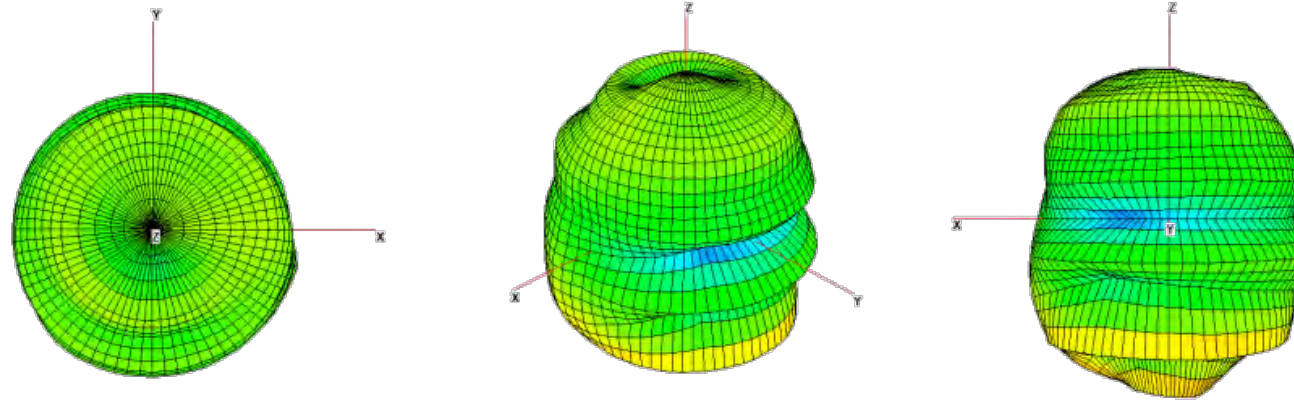

B12

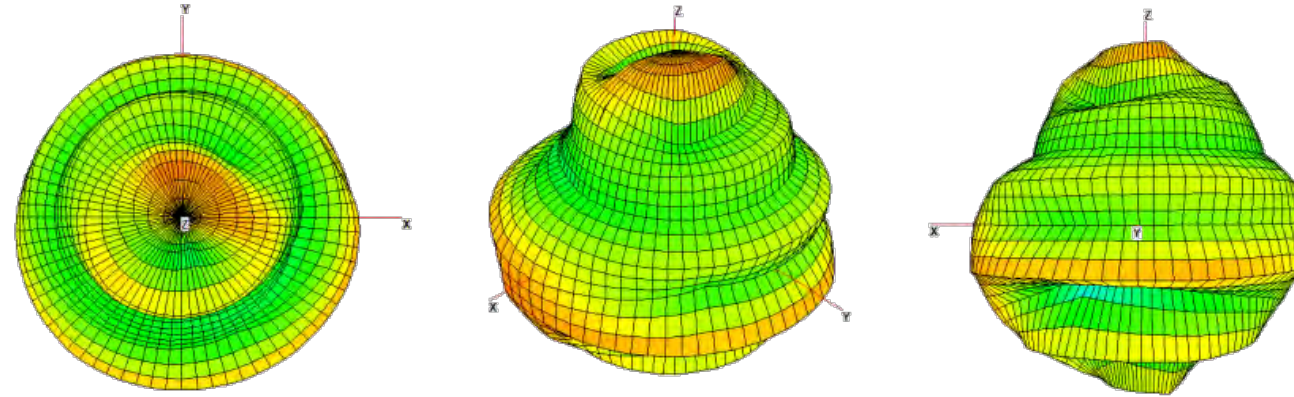

B5

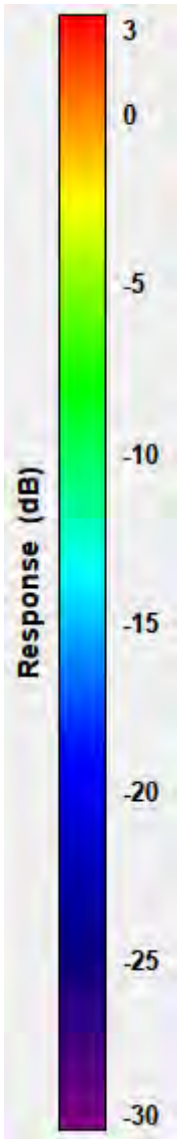
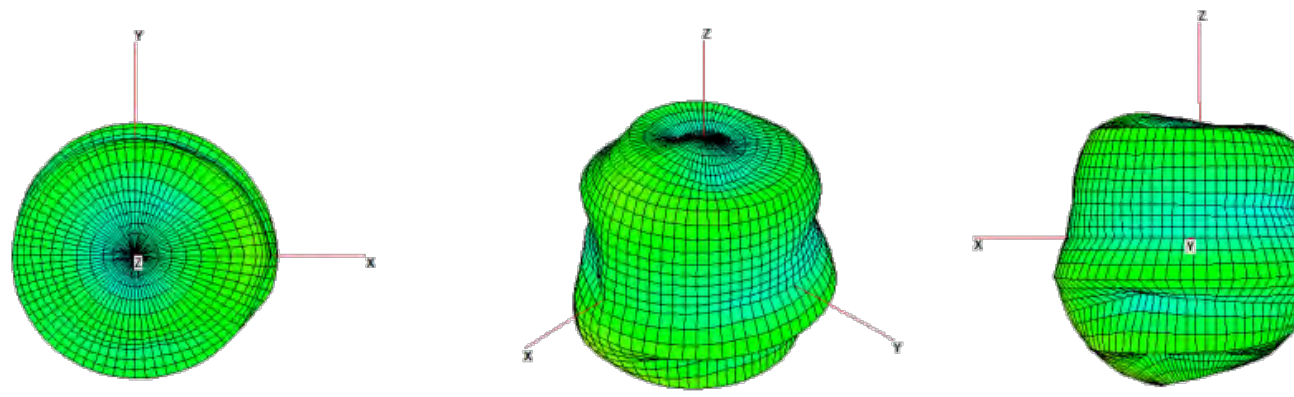

# 3D Radiation Pattern – Ant 1 @MHB

B66

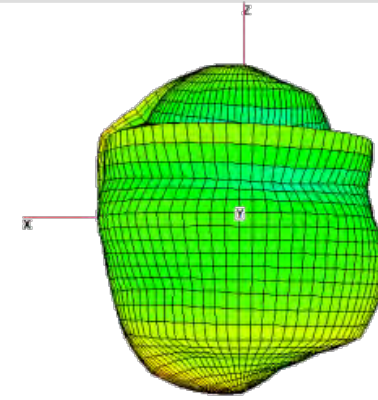
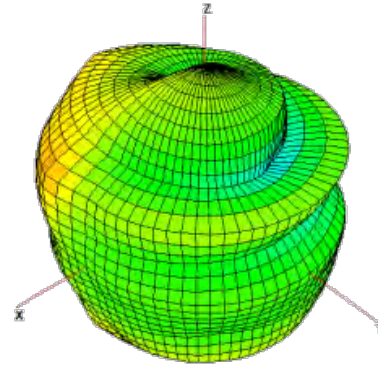
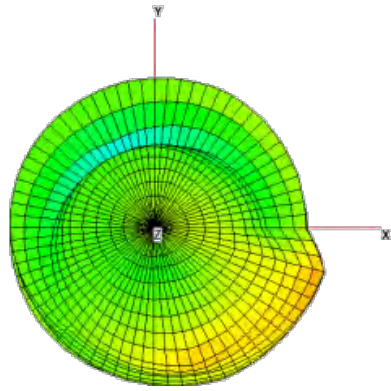

B2/25

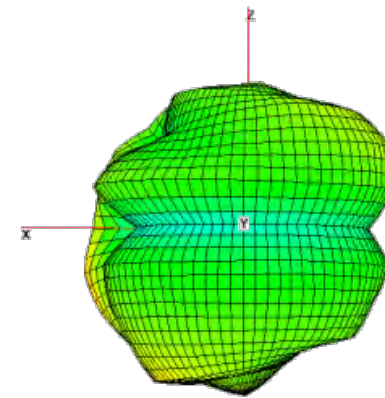
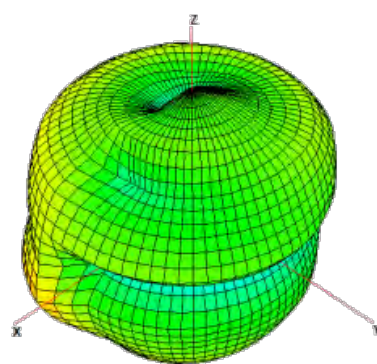
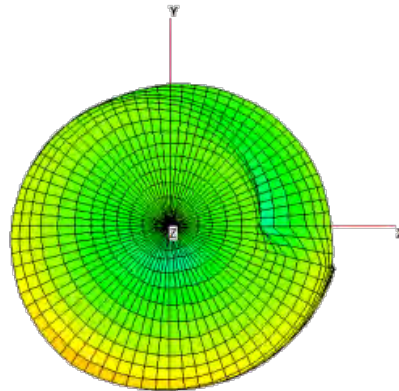

n41

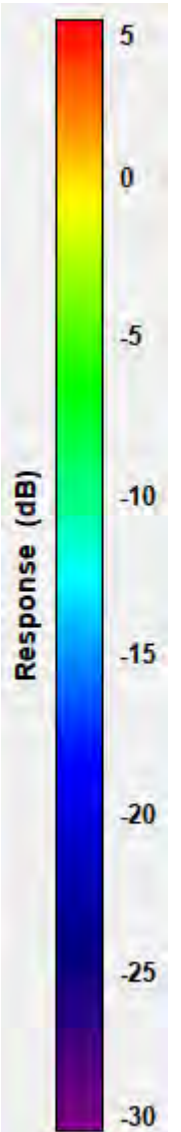
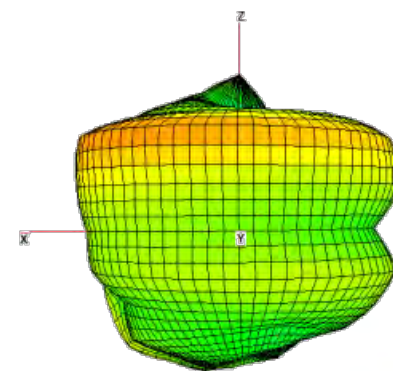
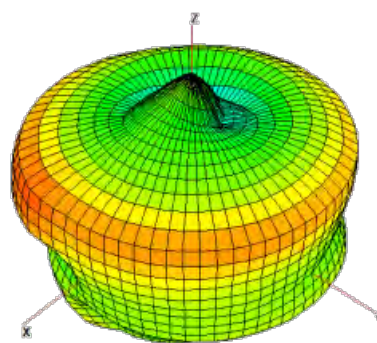
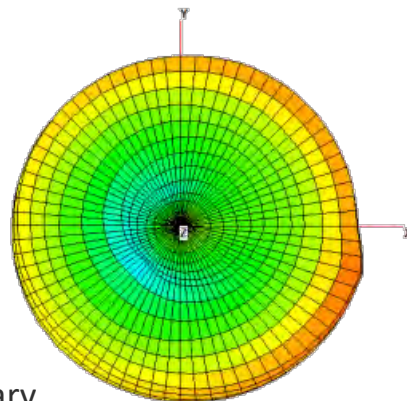



# 3D Radiation Pattern – Ant 2 @MHB

B66

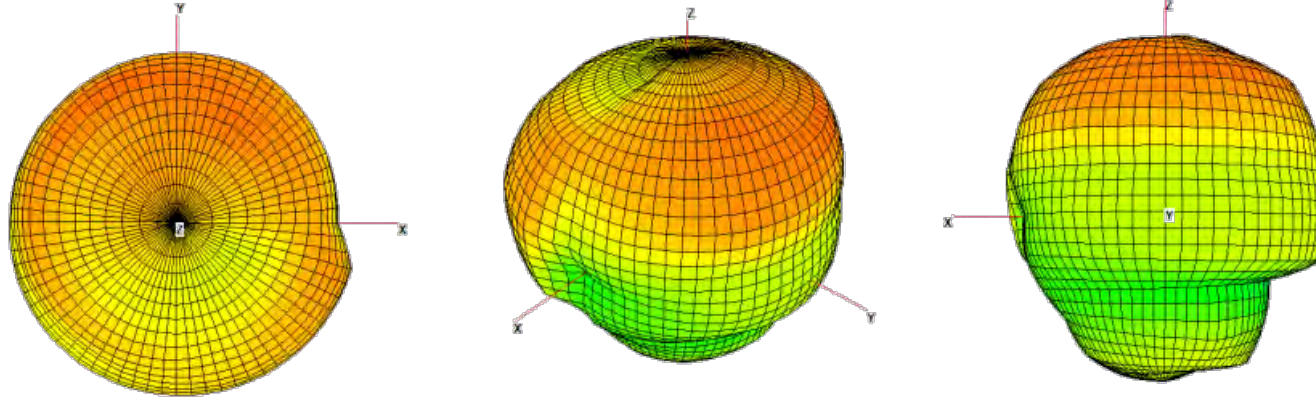

B2/25

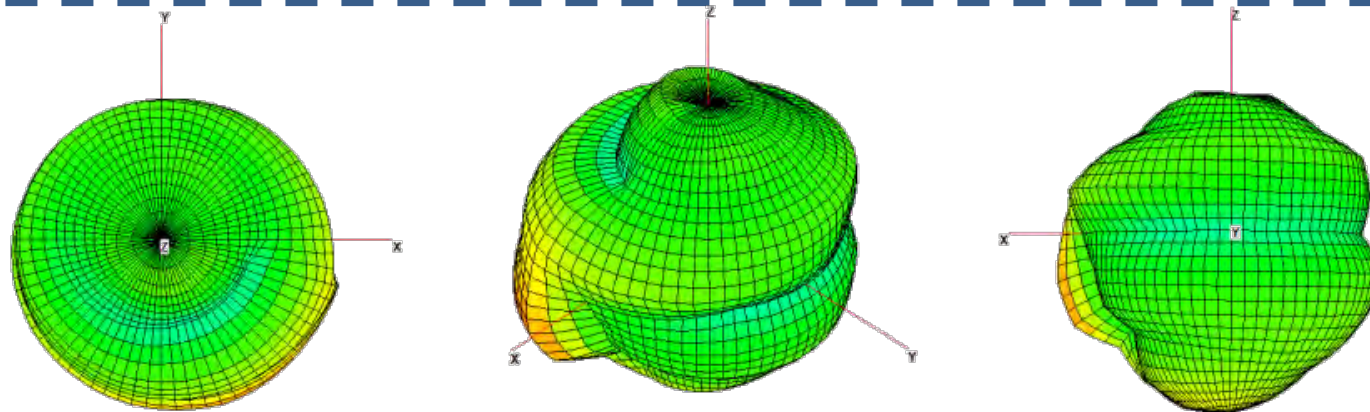

n41

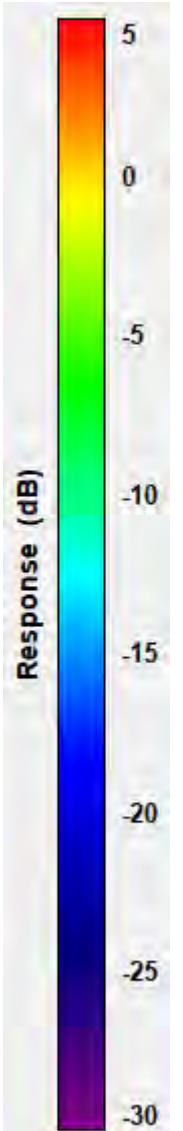
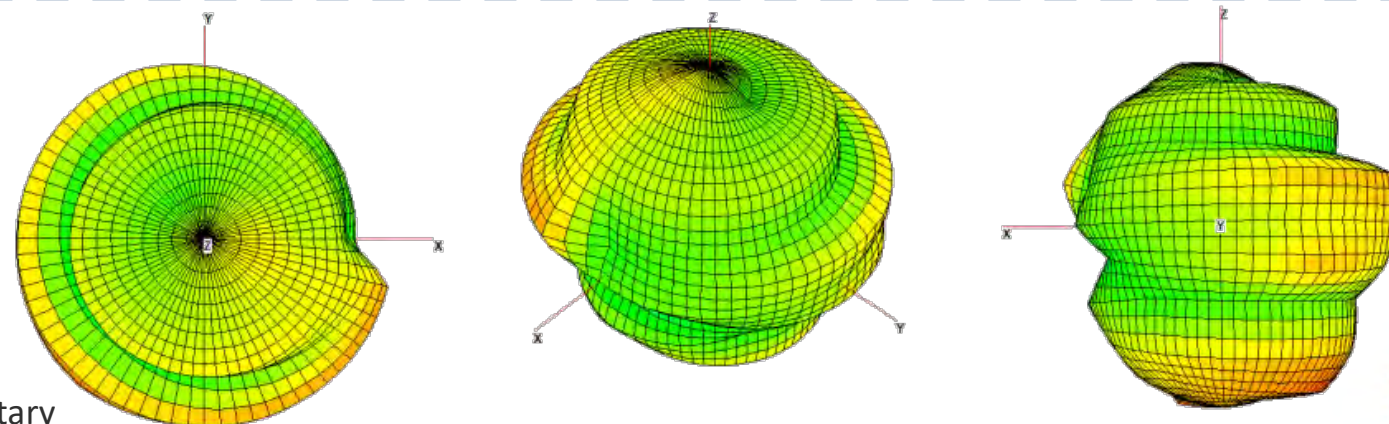



# 3D Radiation Pattern – Ant 2 @UHB

n77/B48

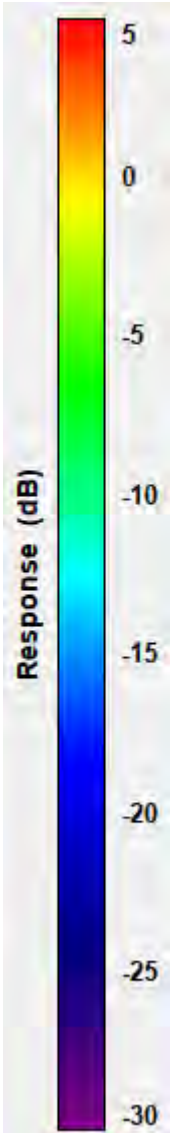
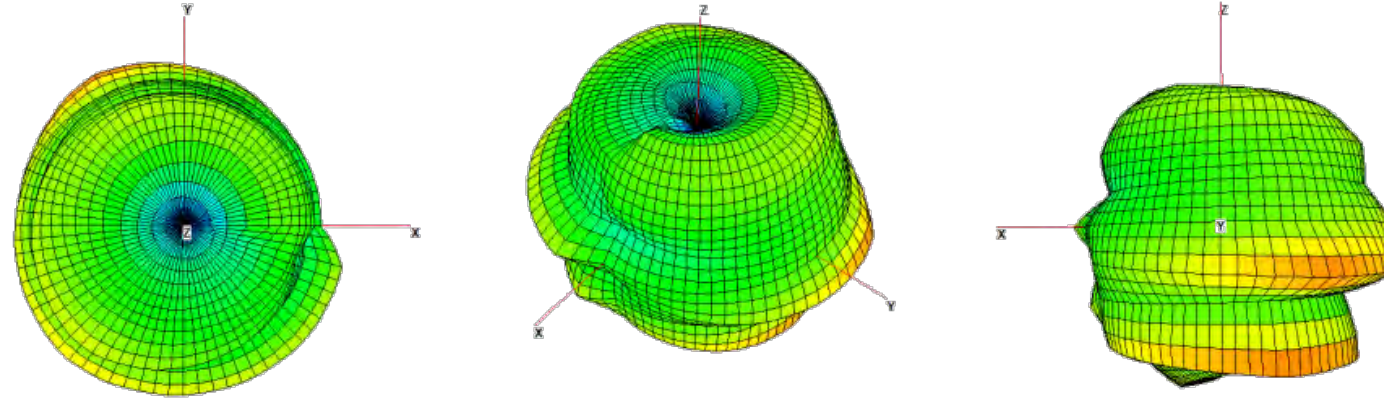

# 3D Radiation Pattern – Ant 3 @LB

n71

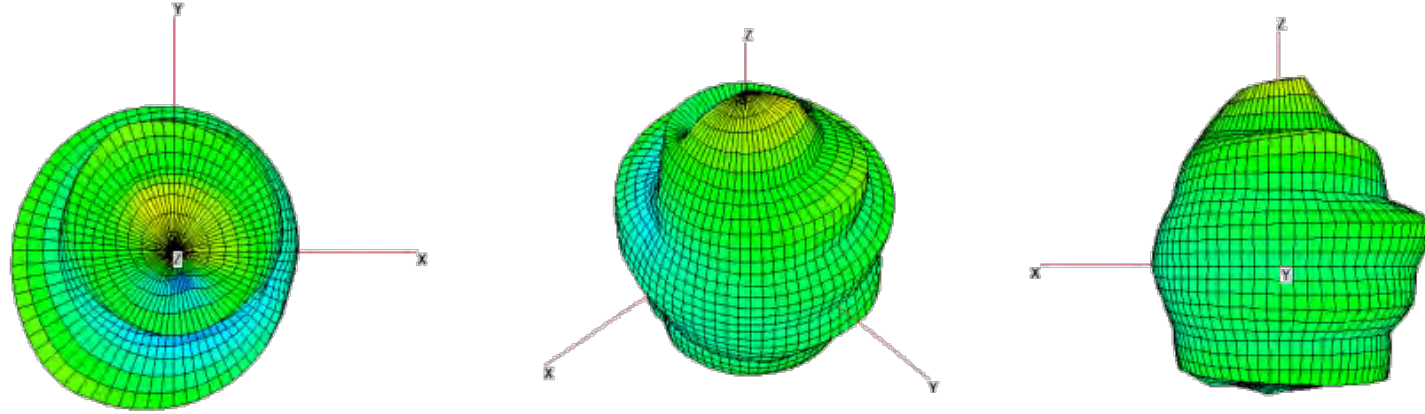

B12

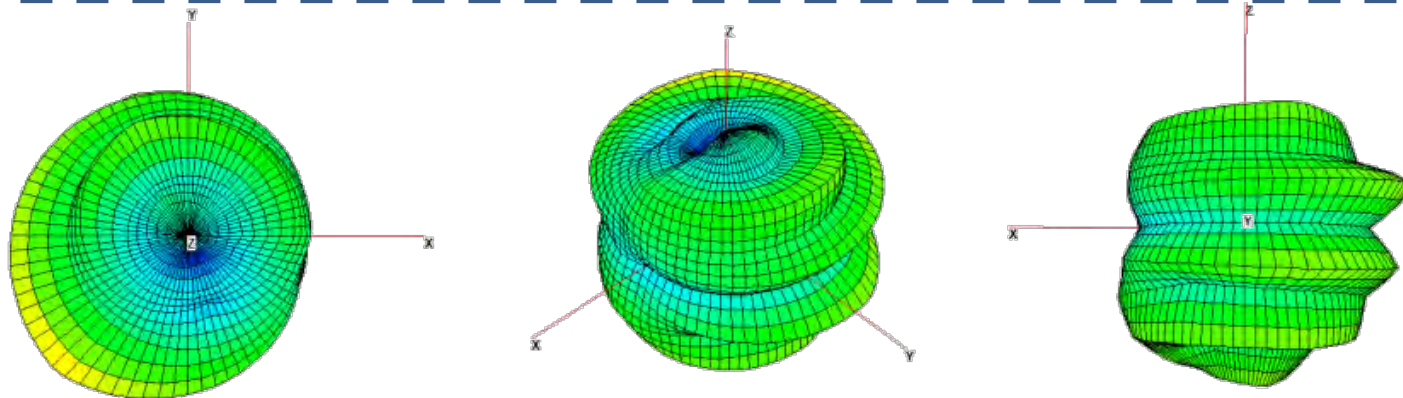

B5

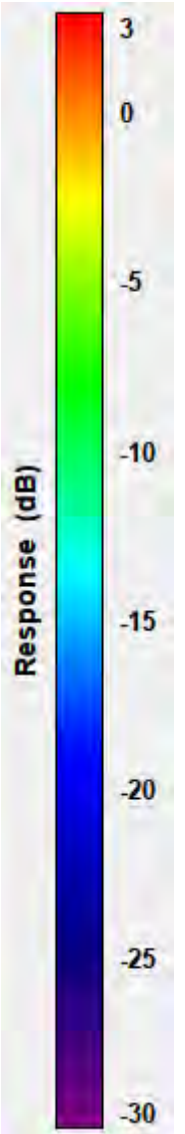
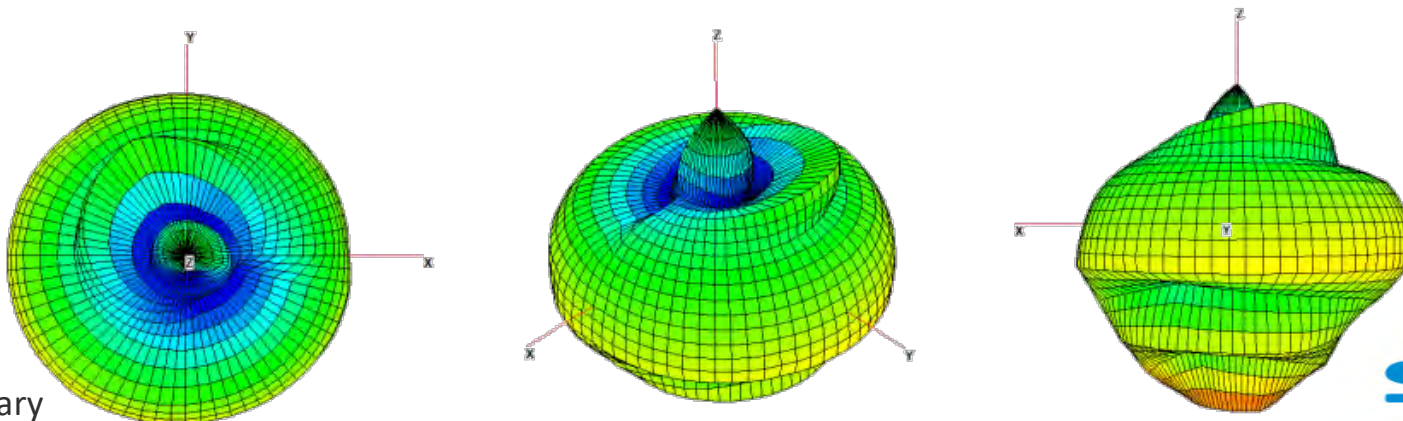



# 3D Radiation Pattern – Ant 3 @MHB

B66

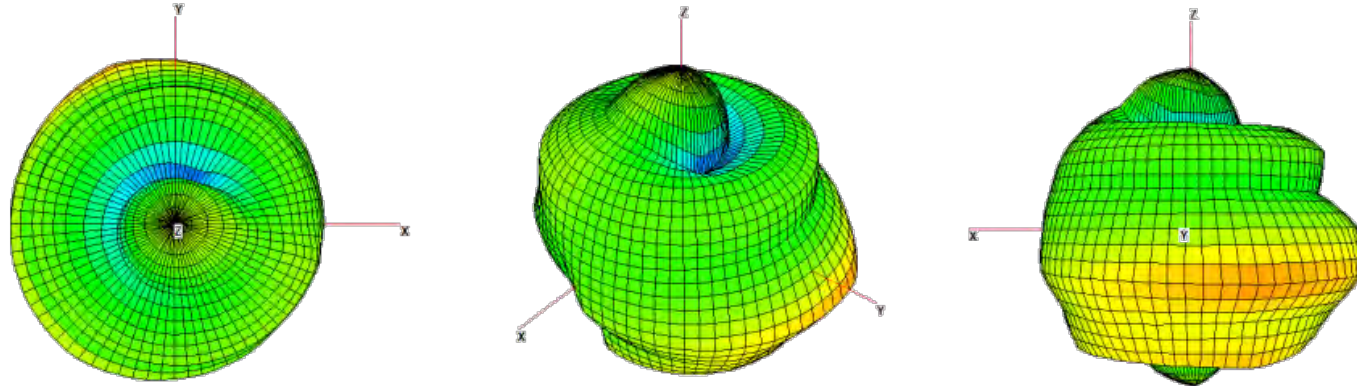

B2/25

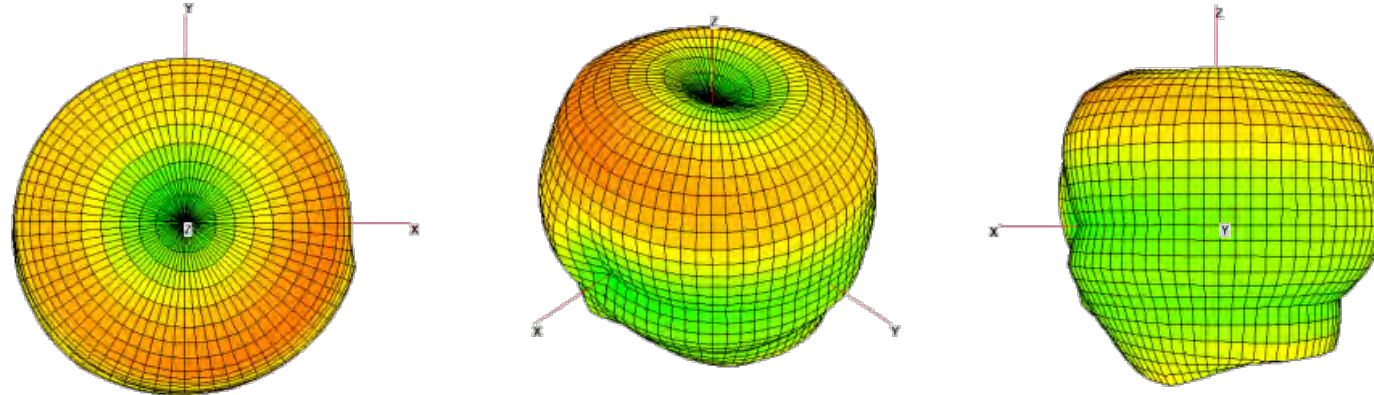

n41

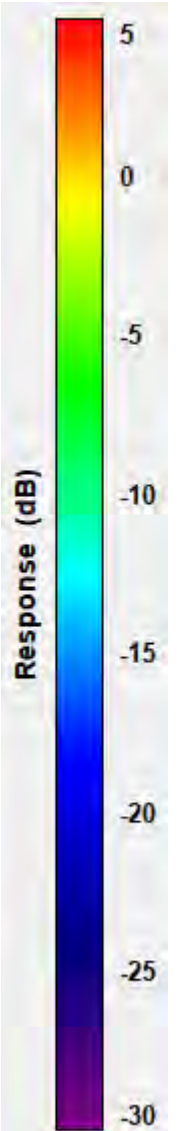
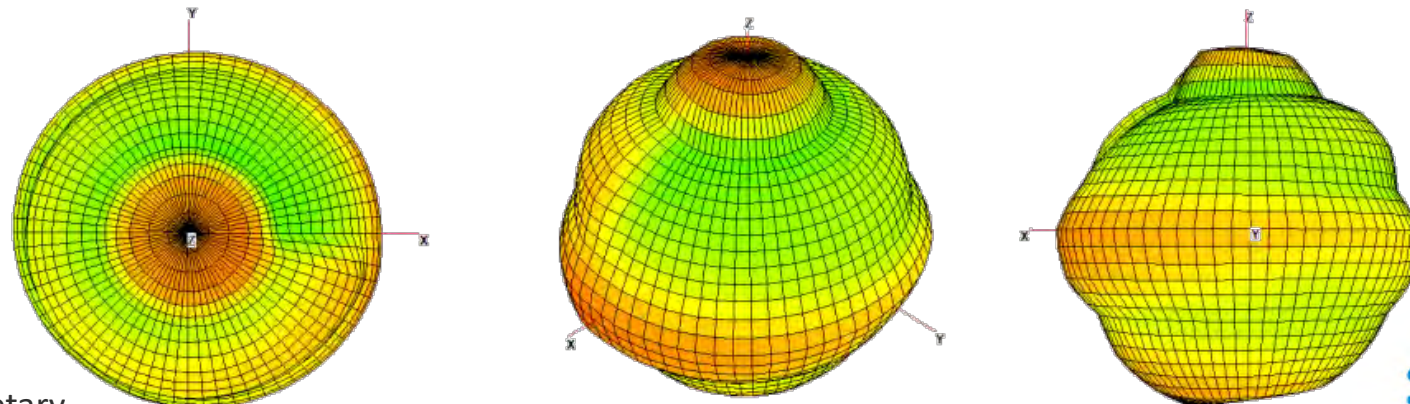



# 3D Radiation Pattern – Ant 4 @LB

n71

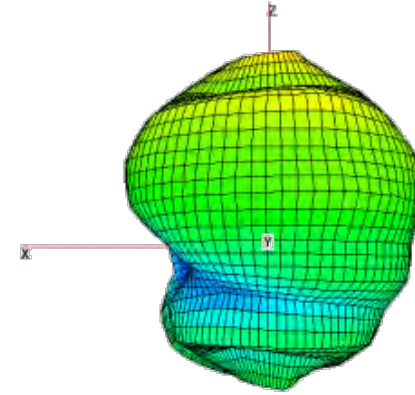
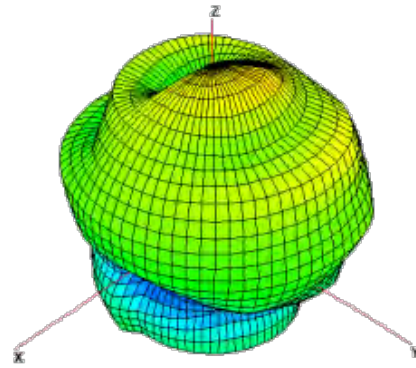
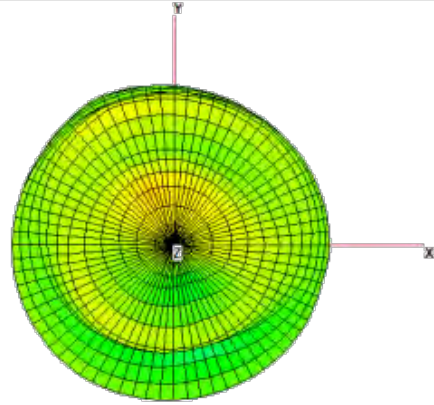

B12

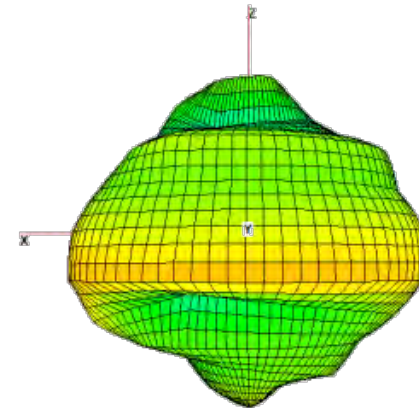
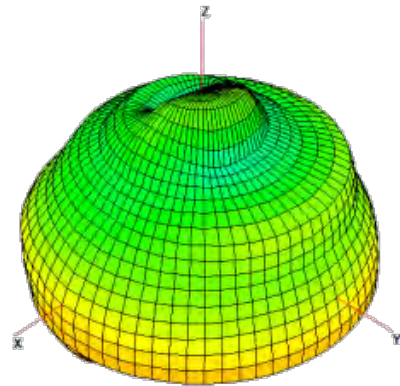
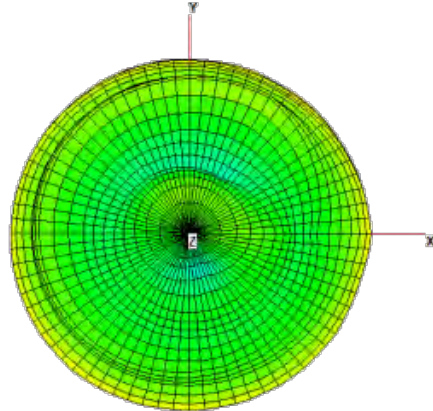

B5

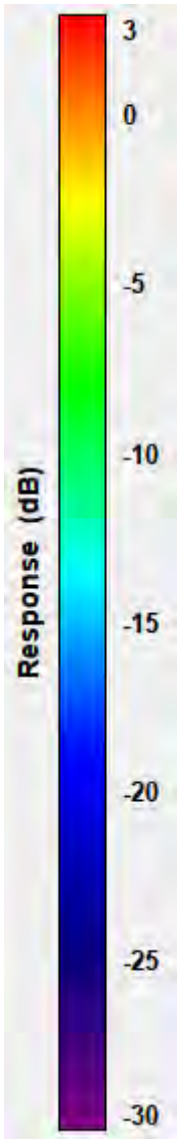
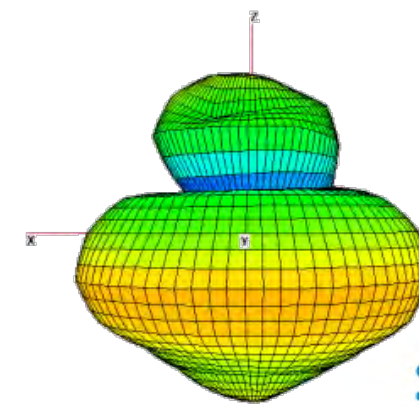
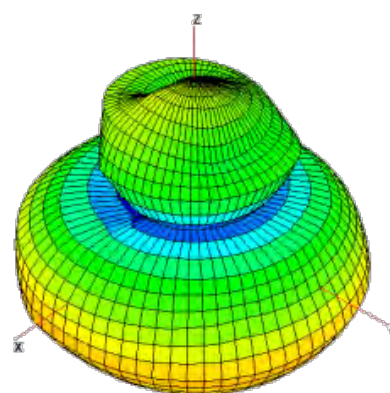
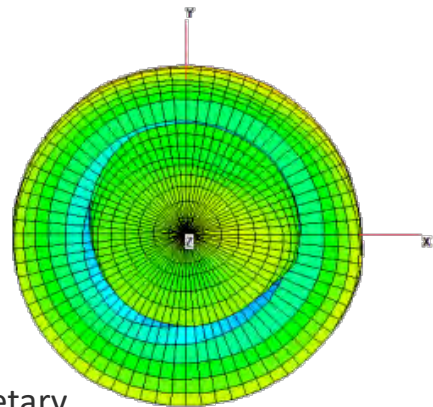



# 3D Radiation Pattern – Ant 4 @MHB

B66

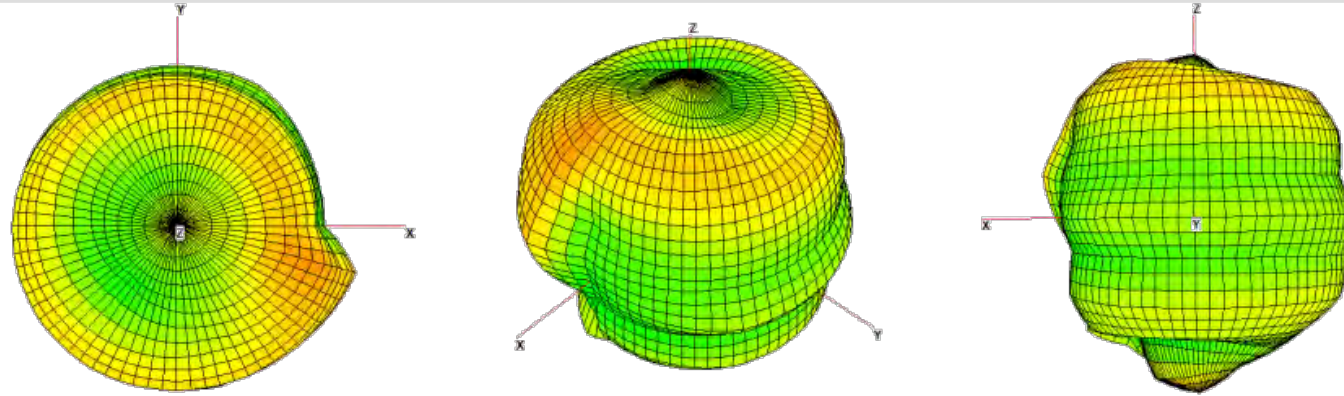

B2/25

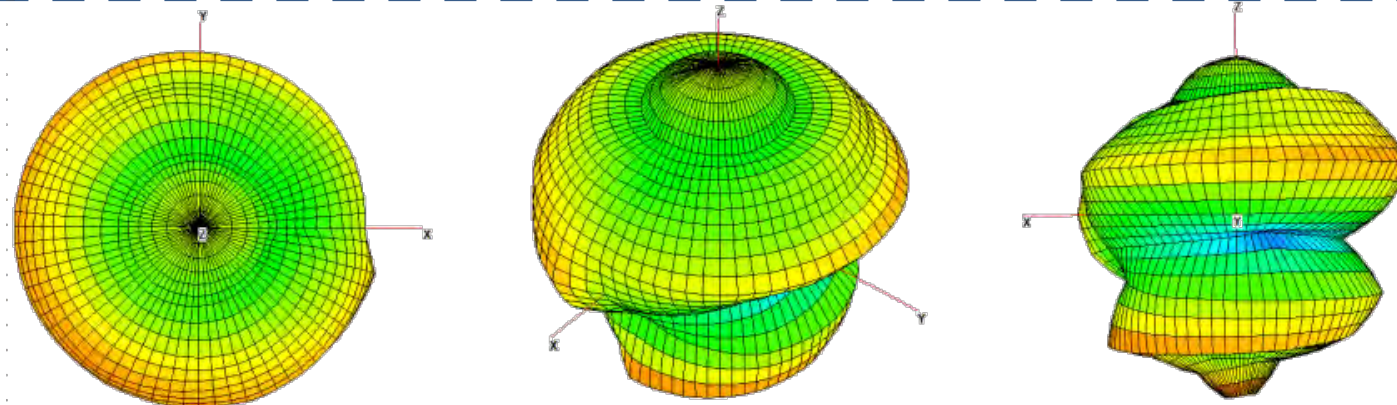

n41

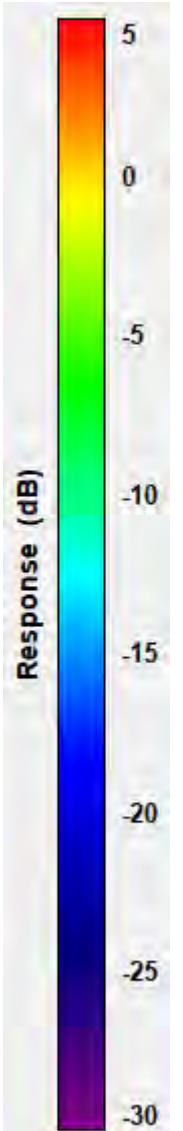
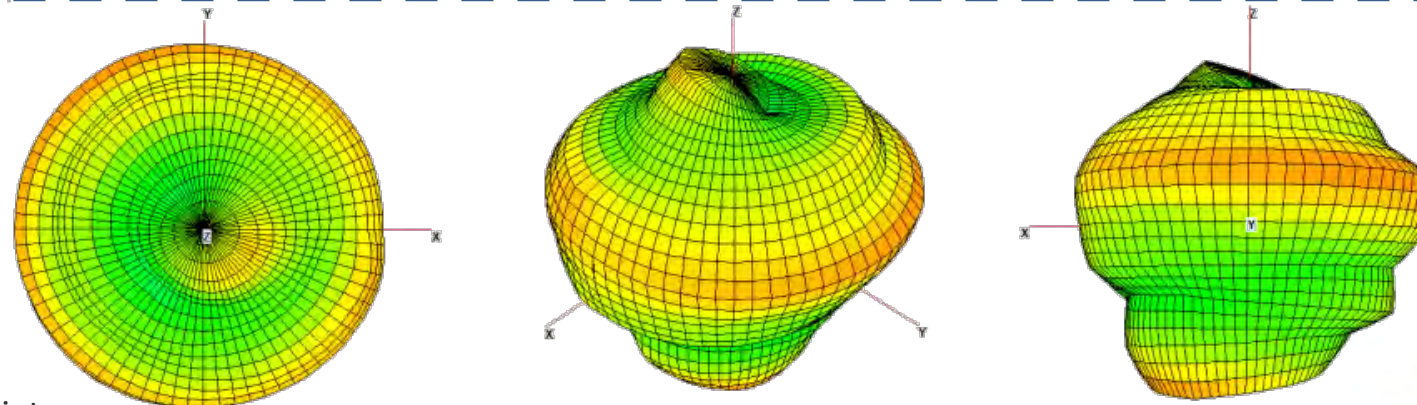

# 3D Radiation Pattern – Ant 4 @UHB

n77/B48

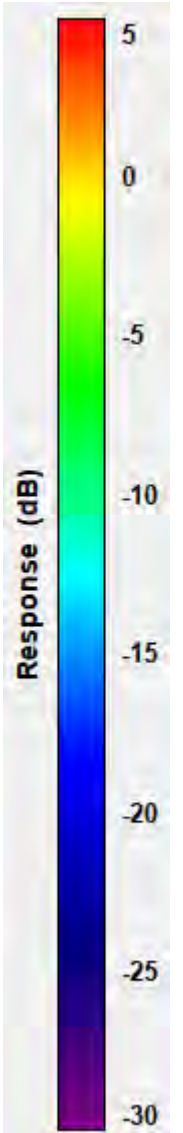
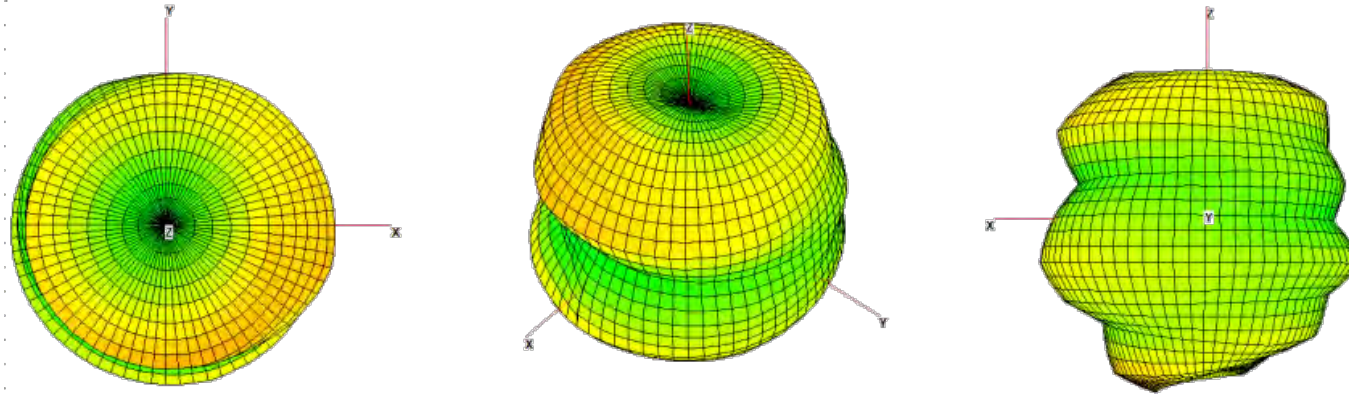



# 3D Radiation Pattern – Ant 5/6 @UHB

n77/B48

Ant 5

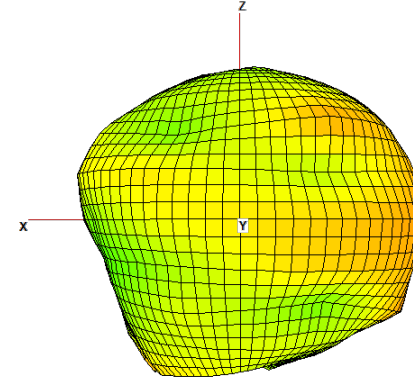
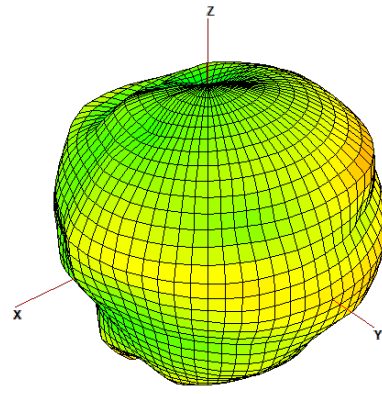
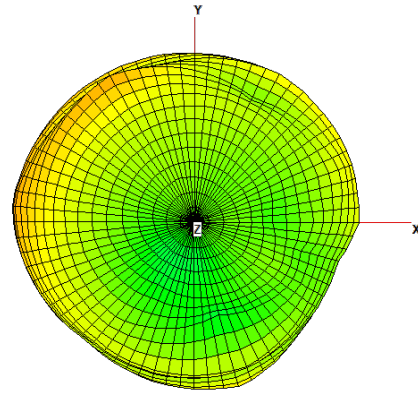

n77/B48

Ant 6

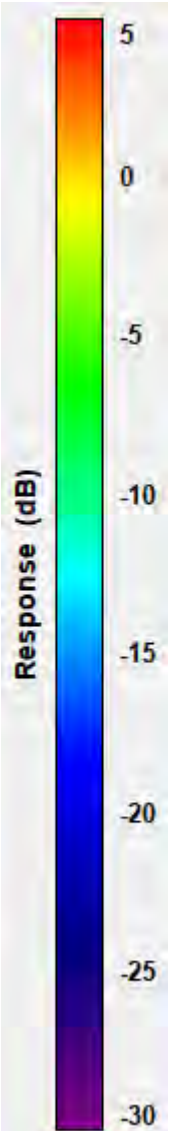
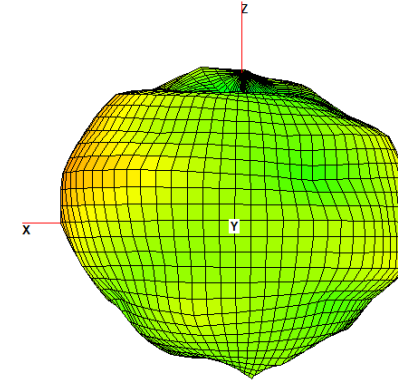
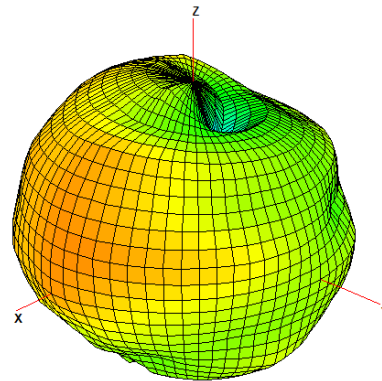
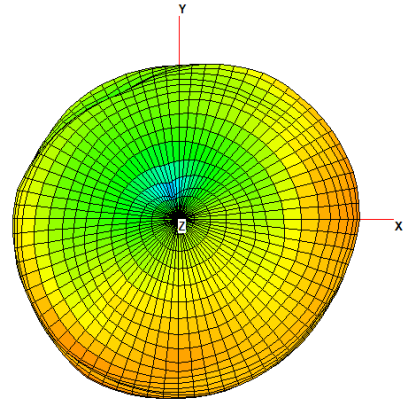

# 3D Radiation Pattern – DA2 @MHB

B66

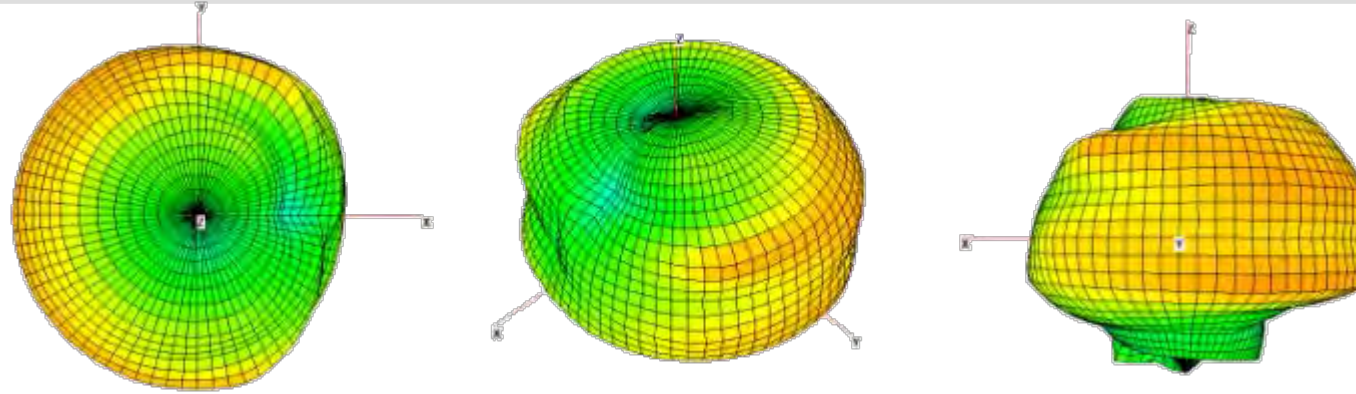

B2/25

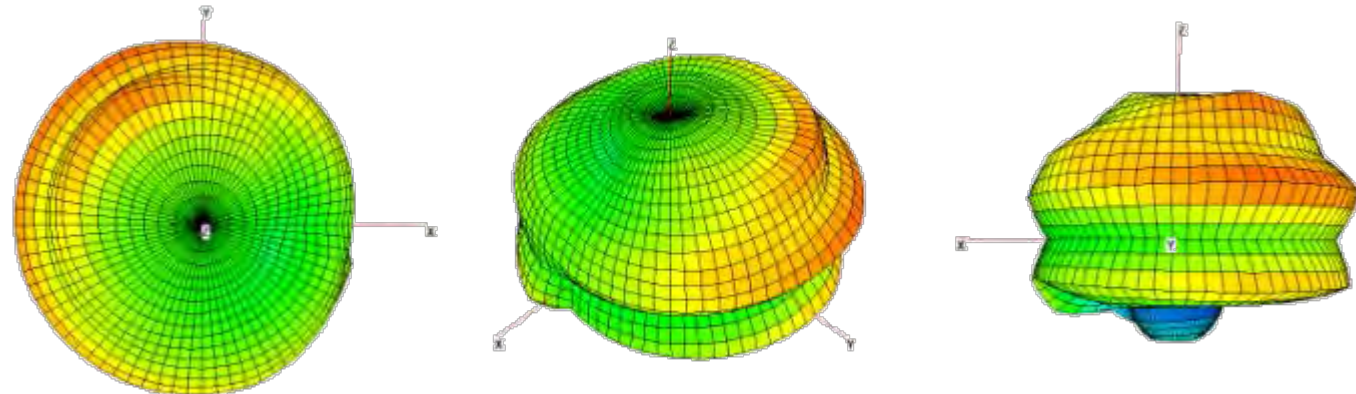

n41

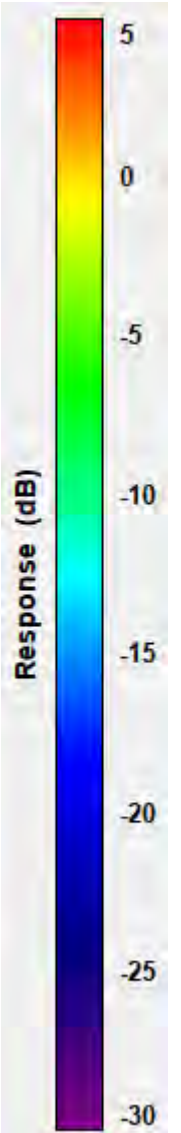
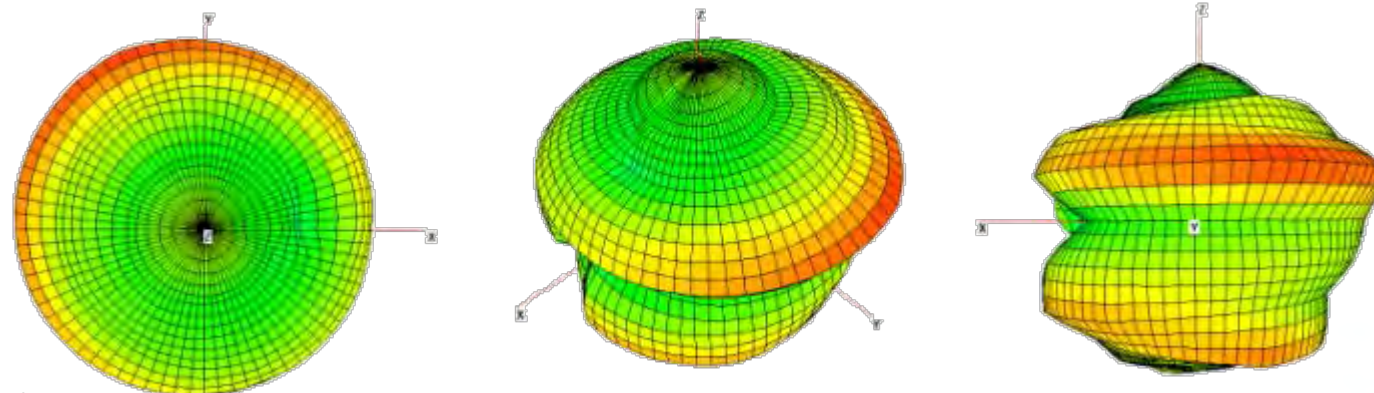



# 3D Radiation Pattern – DA2 @UHB

n77/B48

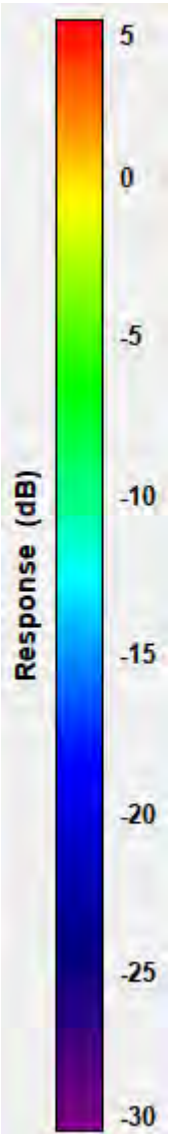
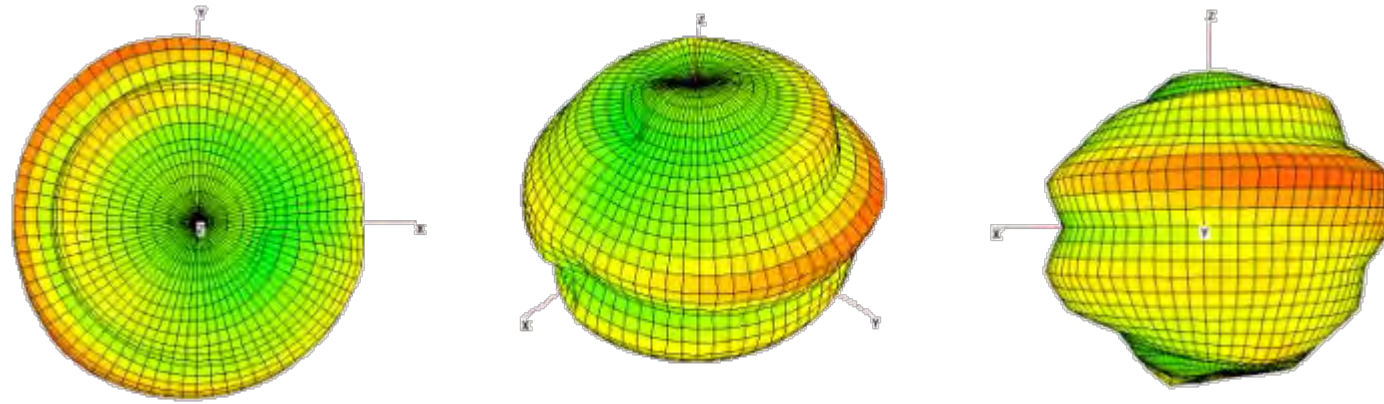

# 3D Radiation Pattern – DA4 @LB

n71

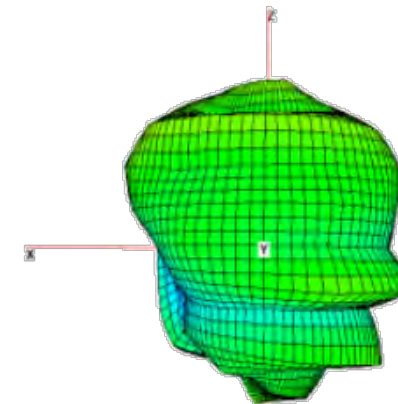
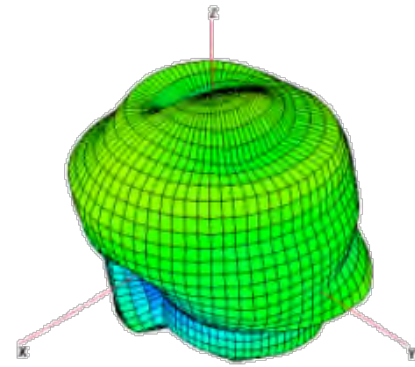
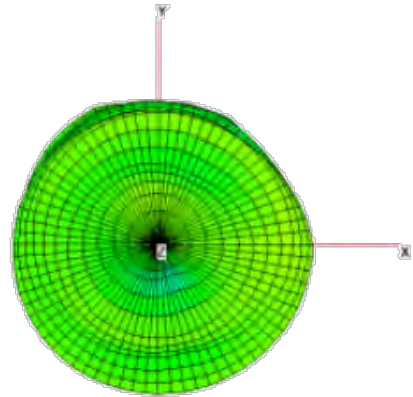

B12

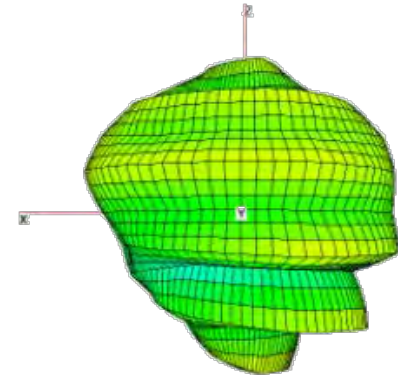
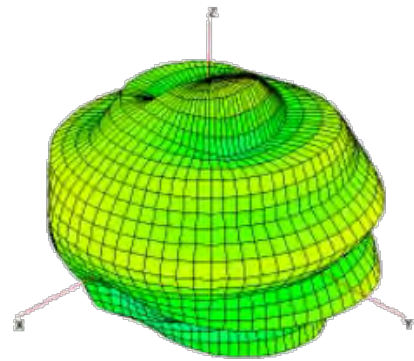
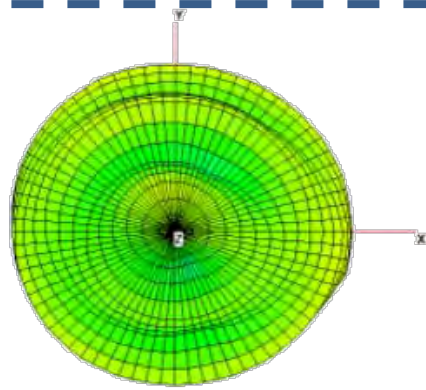

B5

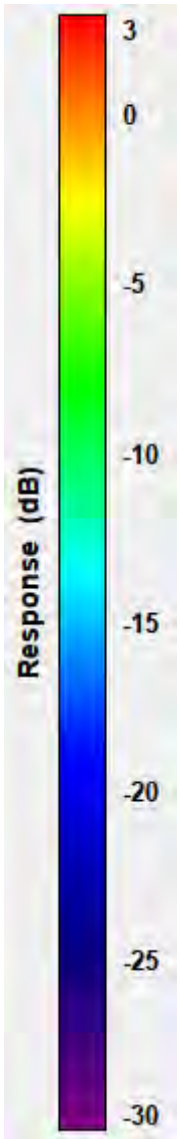
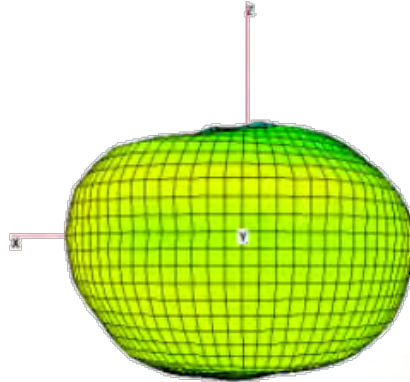
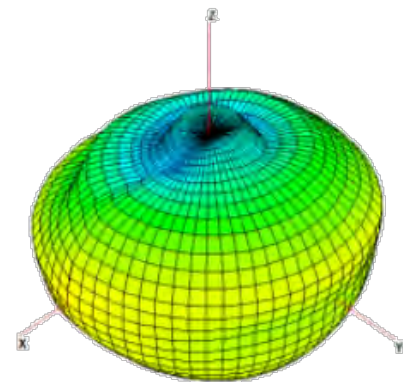
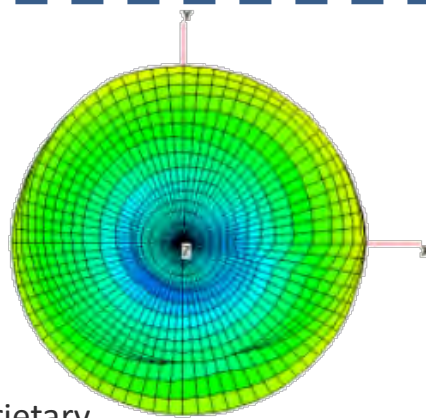



# 3D Radiation Pattern – DA4 @MHB

B66

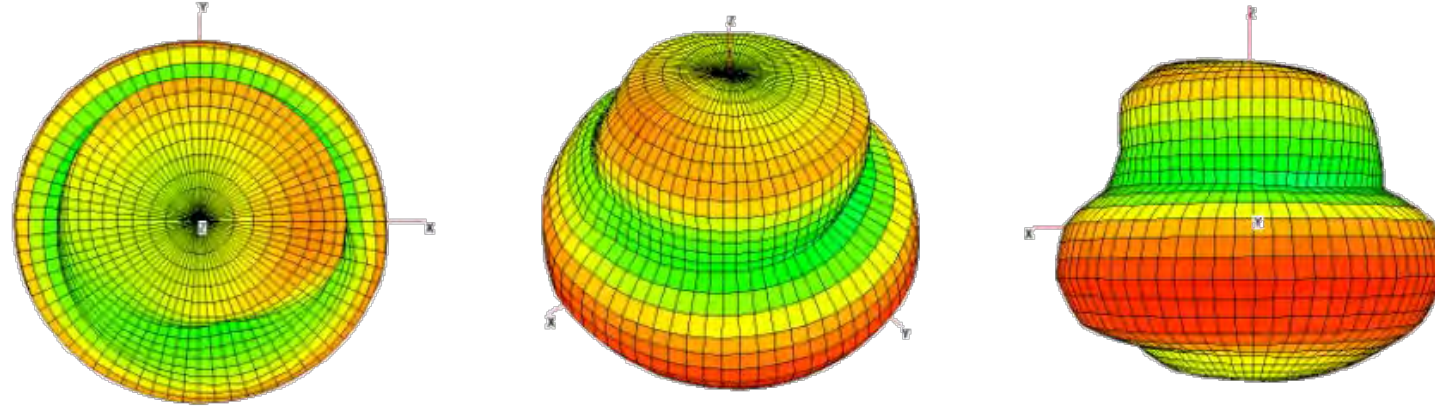

B2/25

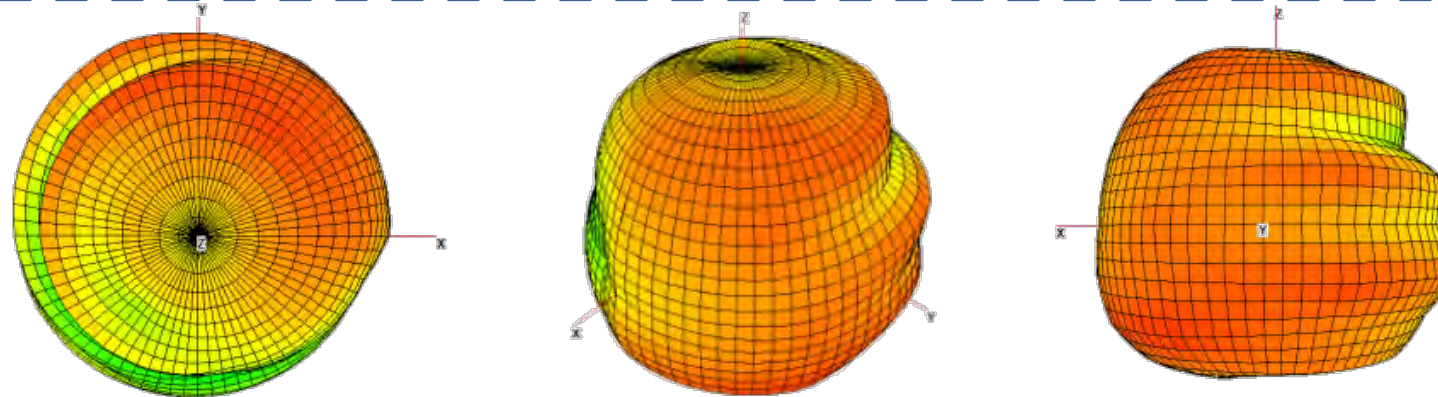

n41

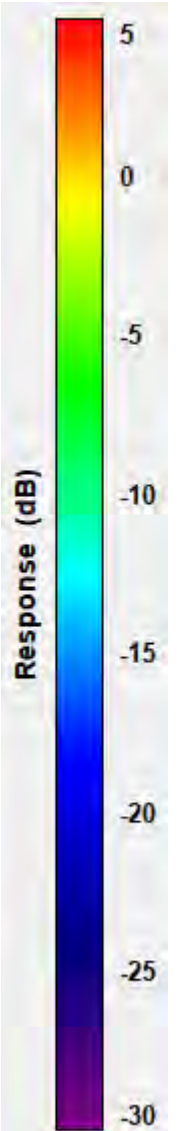
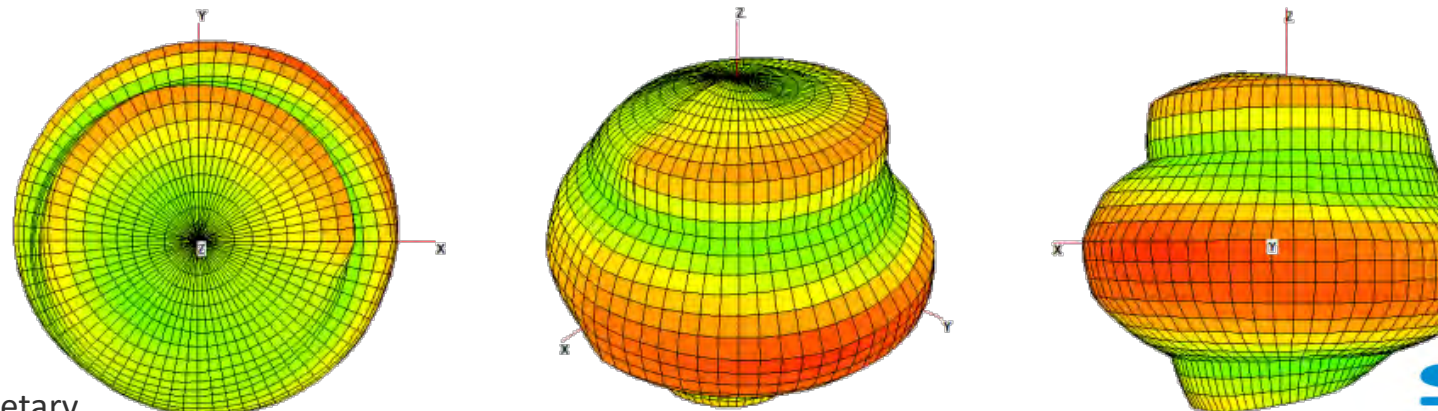



# 3D Radiation Pattern – DA4 @UHB

n77/B48

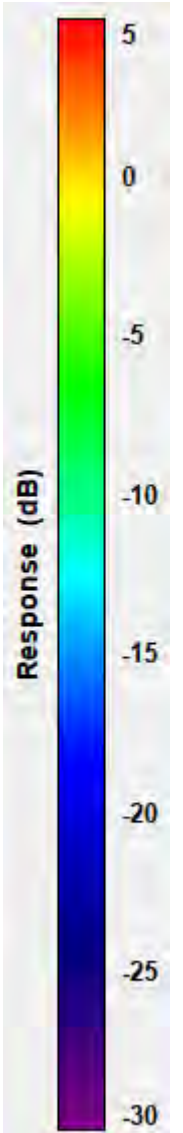
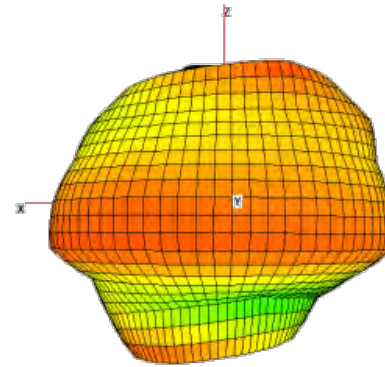
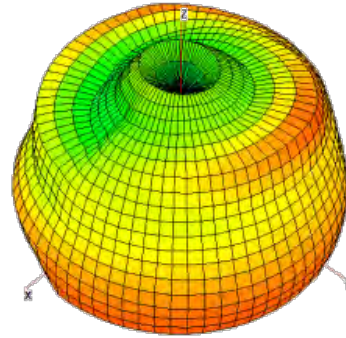
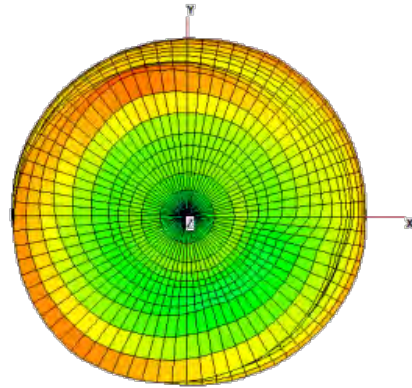

# 3D Radiation Pattern – WFO

2G

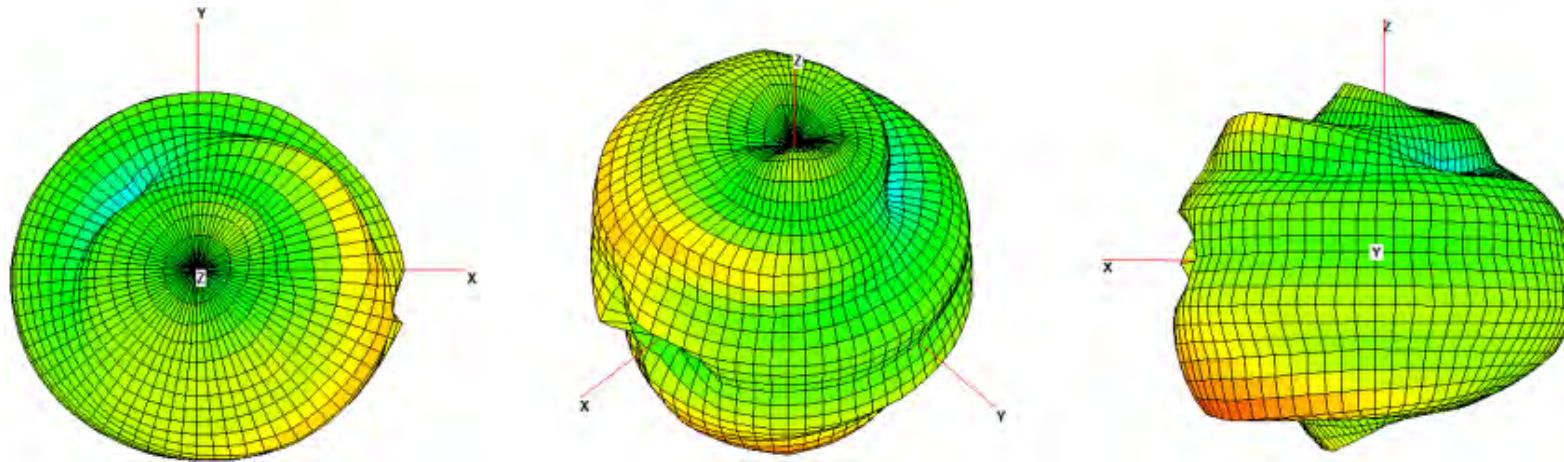

5G

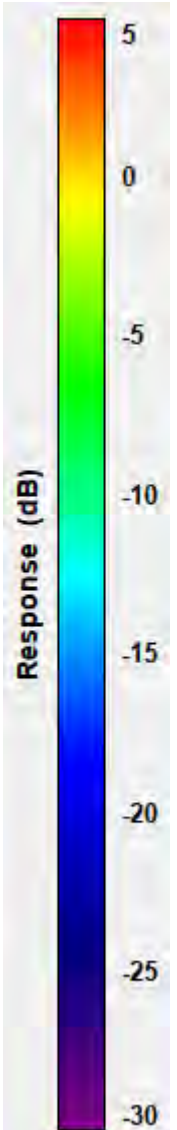
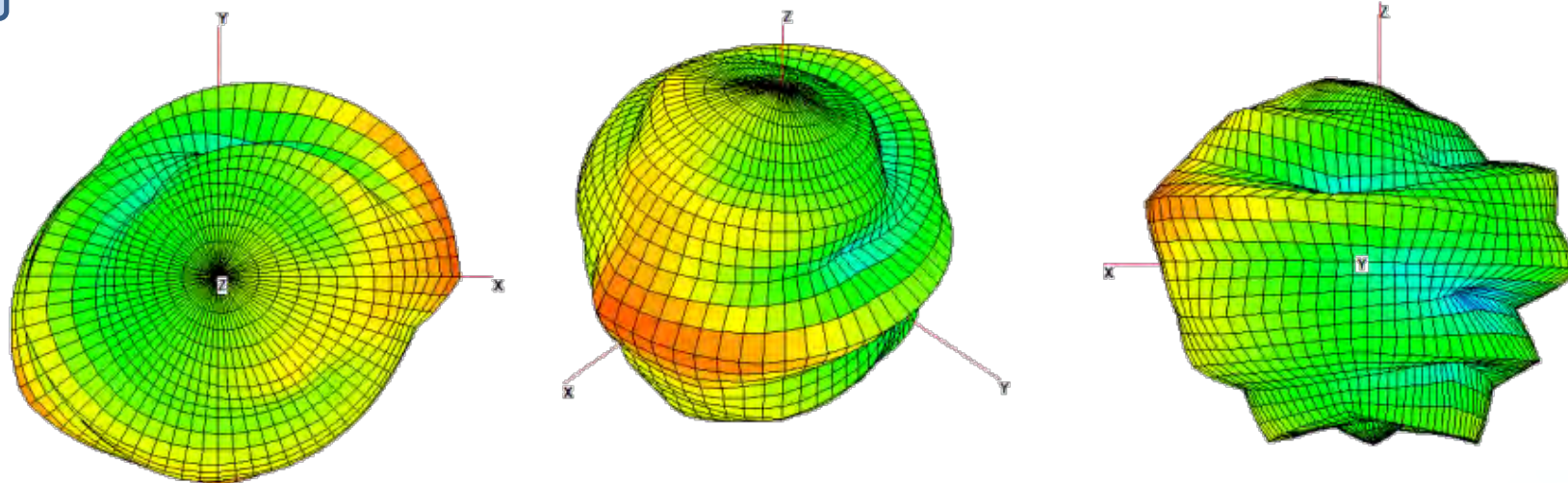



# 3D Radiation Pattern – WF1

2G

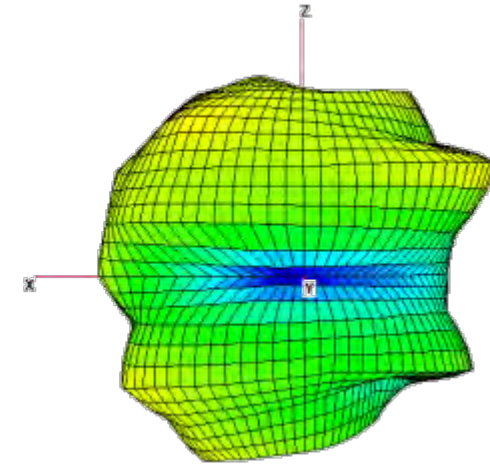
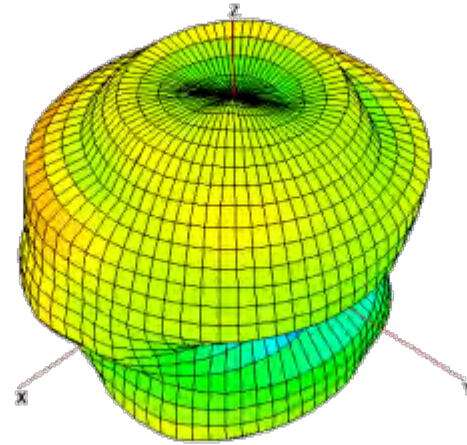
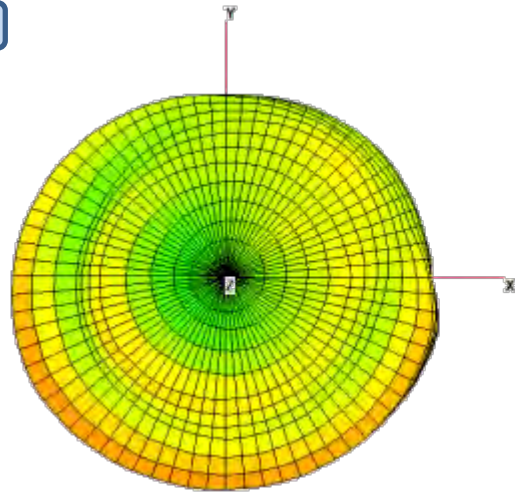

5G

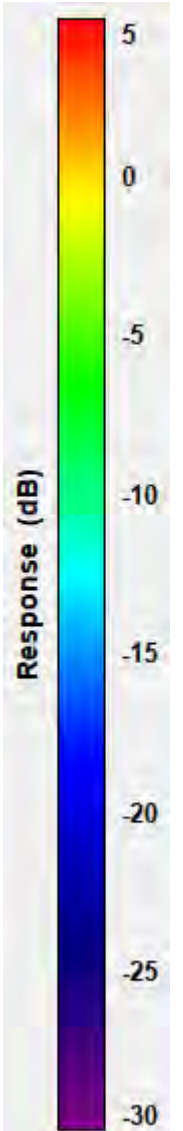
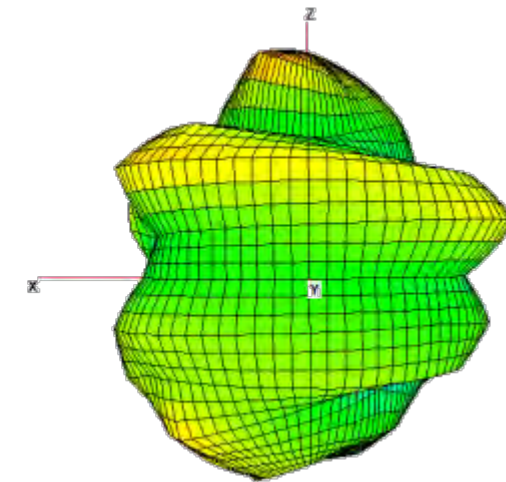
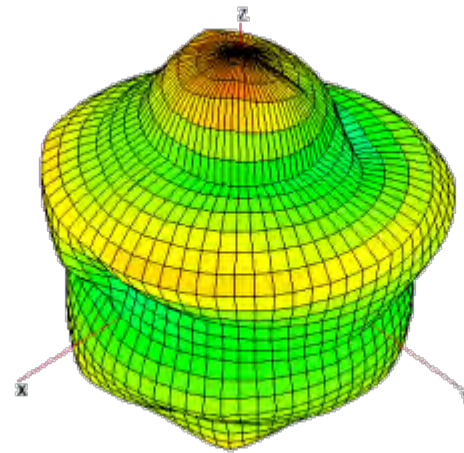
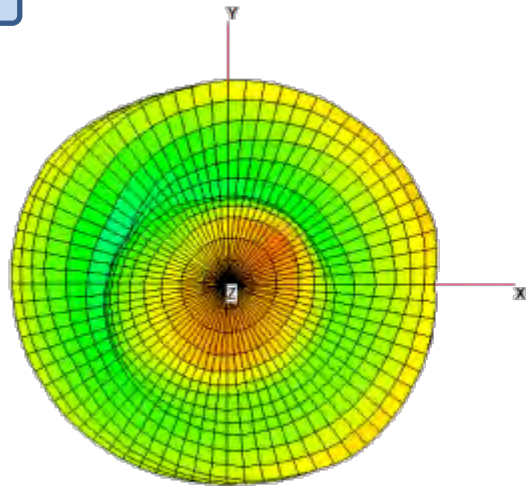



# 3D Radiation Pattern – WF2

2G

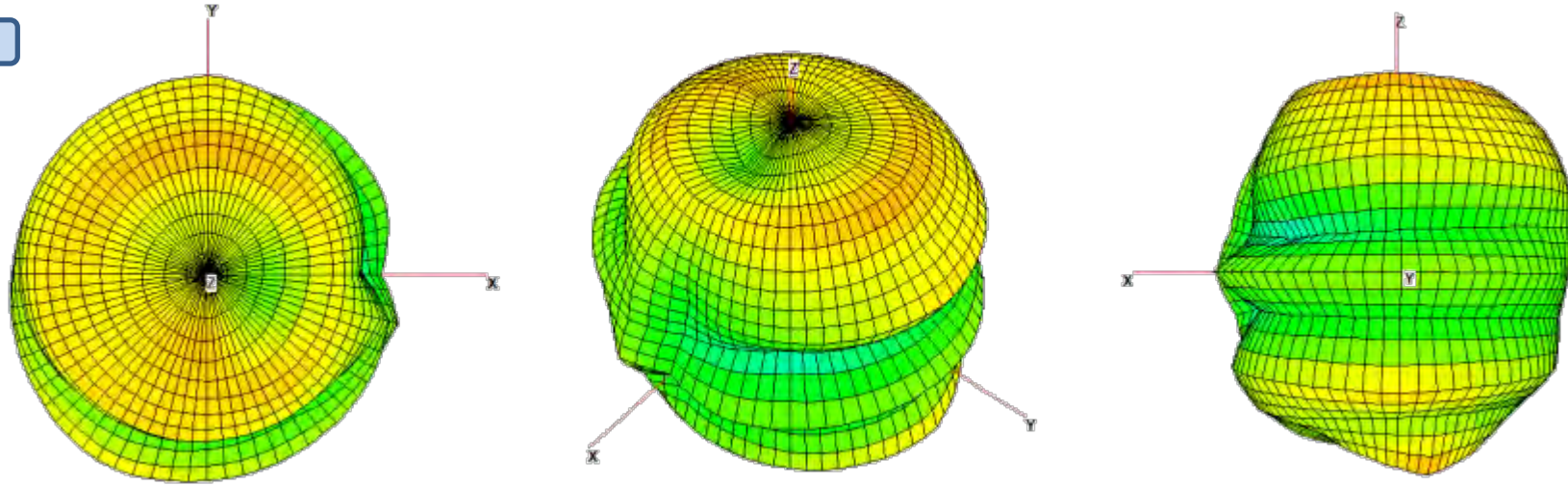

5G

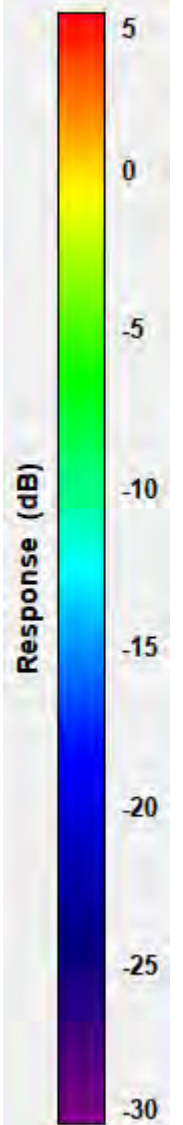
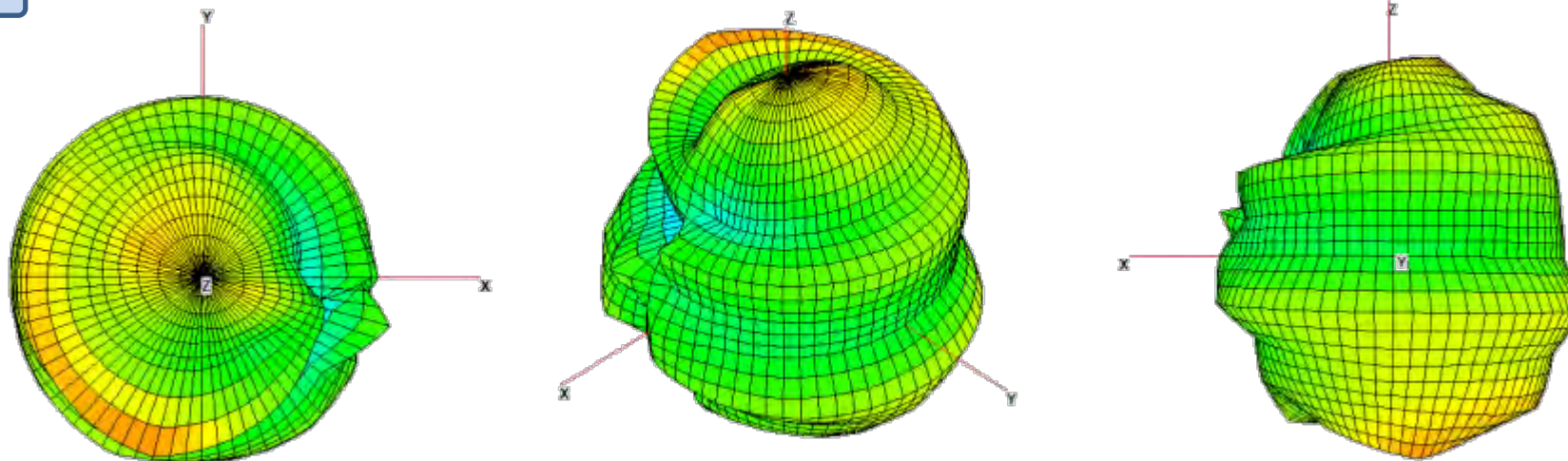

# 3D Radiation Pattern – WF3

2G

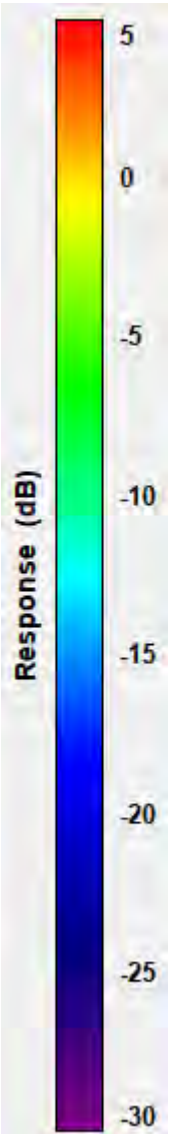
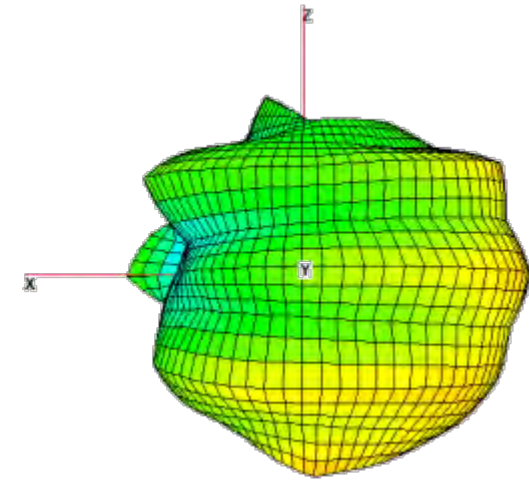
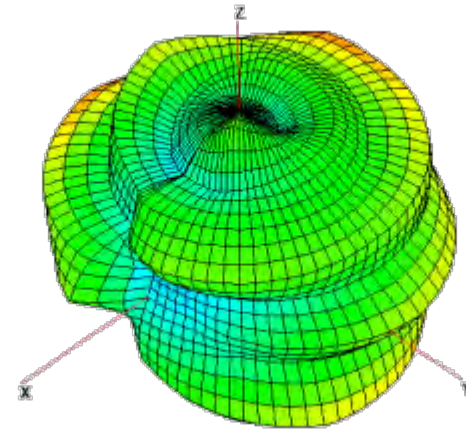
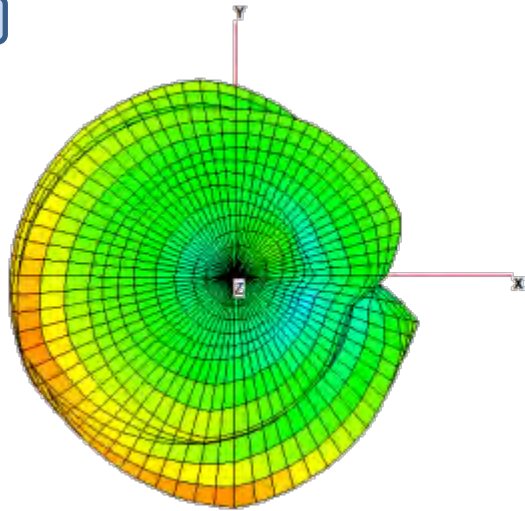

5G

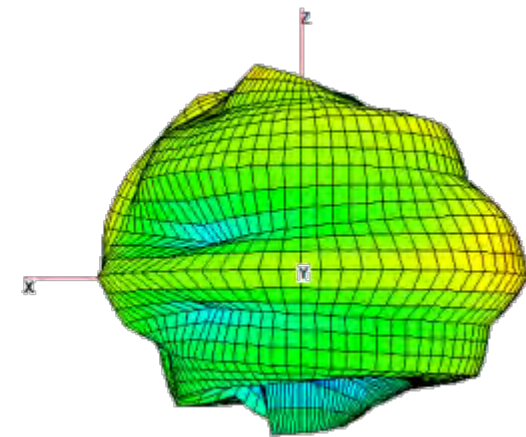
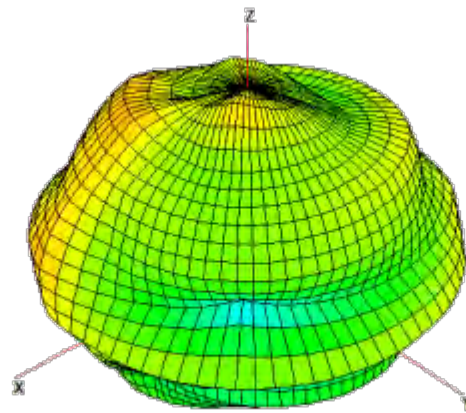
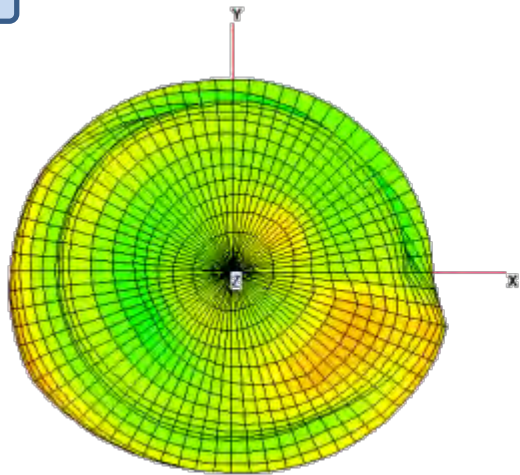



# 3D Radiation Pattern – GPS & BT

GPS

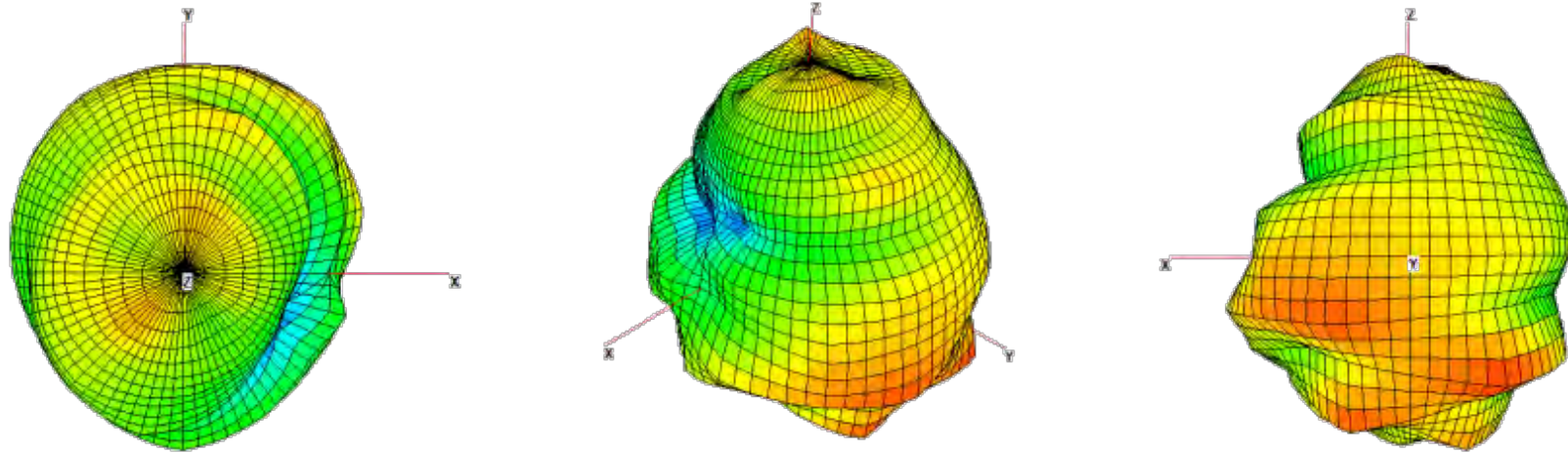

BT

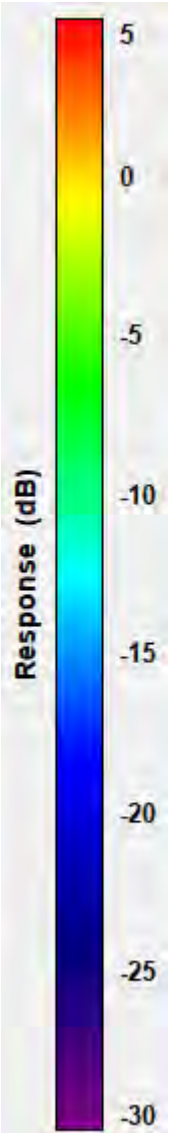
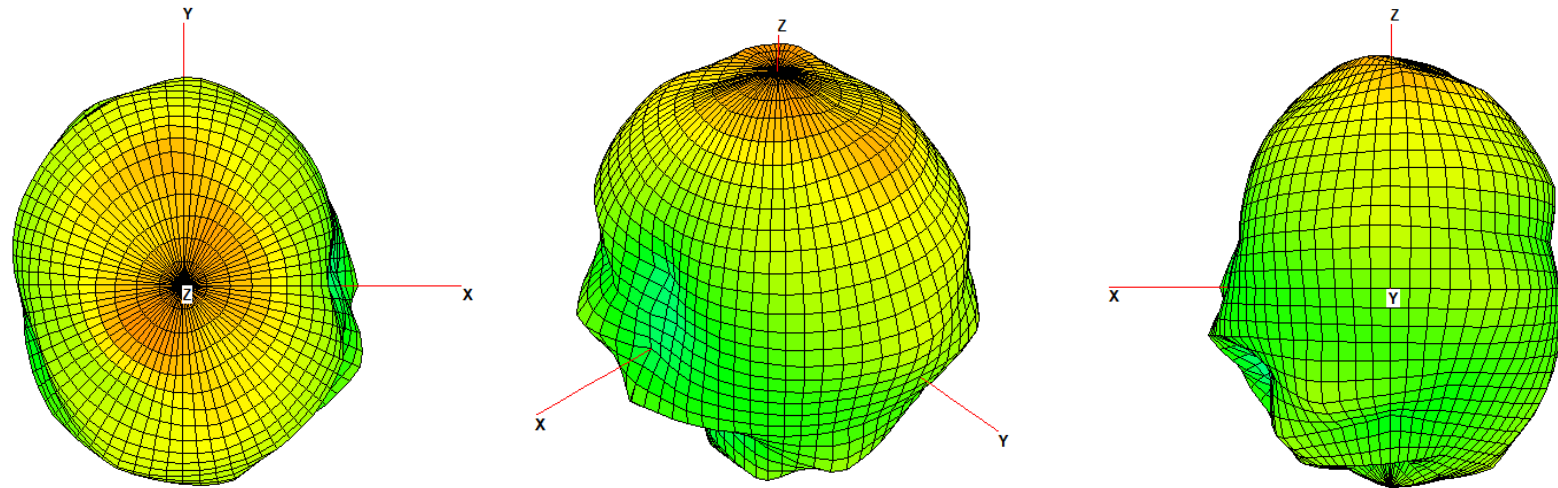



# Peak Gain & Efficiency

		Antenna Performance Data															
		Frequency (MHz)	Ant 0			Ant 1			Ant 2			Ant 3			Ant 4		
			Efficiency (dB)	Efficiency (%)	Gain (dBi)	Efficiency (dB)	Efficiency (%)	Gain (dBi)	Efficiency (dB)	Efficiency (%)	Gain (dBi)	Efficiency (dB)	Efficiency (%)	Gain (dBi)	Efficiency (dB)	Efficiency (%)	Gain (dBi)
LTE Band 71	TX	663	-3.4	45.7	0.8												
		680.5	-3.8	41.9	1.3												
		698	-3.1	49.5	0.9												
	RX	617	-4.1	38.8	-1.9	-4.5	35.5	-1.6				-5.1	30.6	-0.9	-5.6	27.7	-1.6
		634.5	-3.6	44.1	-0.5	-4.3	37.2	0.0				-4.8	33.2	-1.4	-5.2	30.3	-0.9
		652	-3.5	44.8	0.1	-3.8	41.7	-0.2				-4.2	37.8	-1.0	-4.4	36.3	-1.1
LTE Band 12	TX	699	-3.1	49.5	0.9												
		707	-2.8	52.5	1.4												
		716	-2.7	53.2	-0.1												
	RX	729	-2.9	50.8	0.1	-3.3	46.7	0.5				-4.4	36.6	-0.5	-4.2	37.7	0.4
		737	-2.8	52.4	-0.3	-3.1	49.5	1.1				-4.0	39.7	0.3	-4.6	34.5	1.1
		746	-2.5	55.7	0.9	-2.8	53.0	1.7				-3.5	45.1	0.5	-5.1	31.1	1.2
LTE Band 5	TX	824	-4.5	35.6	1.2												
		836	-4.5	35.9	1.7												
		849	-4.2	37.9	2.2												
	RX	869	-4.2	38.1	2.3	-4.3	36.8	-0.2				-5.9	25.8	-0.5	-4.4	36.6	1.1
		880	-4.1	39.2	2.0	-5.0	31.7	-1.1				-5.7	27.0	-0.2	-4.8	33.4	1.1
		894	-4.4	36.4	1.9	-5.5	27.9	-2.5				-5.0	31.6	-0.7	-5.0	31.4	1.3
LTE Band 66	TX	1710						-2.3	58.8	1.8				-2.8	53.1	1.2	
		1745									-2.1	62.3	1.7	-2.3	58.4	1.7	
		1780									-2.0	62.8	1.8	-2.3	59.3	1.8	
	RX	2110				-4.3	36.8	0.4	-3.5	44.4	1.6	-3.2	47.4	1.9	-1.9	64.7	1.9
		2155				-4.1	39.3	0.7	-2.8	52.9	1.8	-4.5	35.3	1.4	-2.3	58.3	1.7
		2200				-4.0	39.6	0.7	-2.4	57.2	2.5	-4.2	38.1	1.6	-2.2	60.2	1.5
LTE Band 2	TX	1850						-2.8	52.3	2.2				-3.0	50.6	1.6	
		1880									-2.9	51.2	1.9	-2.8	52.3	2.0	
		1910									-2.5	56.3	2.1	-2.2	59.9	2.1	
	RX	1930				-4.0	40.0	-0.6	-2.9	50.9	2.1	-2.9	51.5	2.5	-2.4	56.9	2.1
		1960				-4.4	36.6	-0.6	-2.8	52.3	1.8	-3.6	44.0	1.7	-2.6	54.9	2.3
		1990				-4.5	35.2	-0.1	-2.8	52.9	1.8	-3.8	41.6	1.6	-2.9	51.2	1.7
LTE Band 25	TX	1850						-2.8	52.3	2.2				-3.0	50.6	1.6	
		1883									-2.9	51.2	1.9	-2.8	52.3	2.0	
		1915									-2.5	56.3	2.1	-2.2	59.9	2.1	
	RX	1930				-4.0	40.0	-0.6	-2.9	50.9	2.1	-2.9	51.5	2.5	-2.4	56.9	2.1
		1963				-4.4	36.6	-0.6	-2.8	52.3	1.8	-3.6	44.0	1.7	-2.6	54.9	2.3
		1995				-4.5	35.2	-0.1	-2.8	52.9	1.8	-3.8	41.6	1.6	-2.9	51.2	1.7
LTEB41	TX/RX	2496				-4.1	39.0	2.2	-1.9	64.0	2.6	-3.9	40.4	2.3	-2.1	61.2	2.4
		2593				-4.7	36.2	2.1	-2.2	60.7	2.7	-3.4	46.2	2.3	-2.5	56.9	2.3
		2690				-4.5	38.3	2.4	-1.8	65.5	2.9	-4.0	39.5	2.1	-1.9	64.7	2.7
LTEB48	TX/RX	3550												-3.5	45.2	2.0	
		3625												-3.6	43.2	2.3	
		3700													-3.8	41.5	2.5
LTE n77	TX/RX	3300													-3.0	50.3	2.2
		3750													-3.7	42.3	2.6
		4200														-4.3	37.4

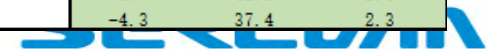

# Peak Gain & Efficiency

		Frequency (MHz)	Ant 5			Ant 6			DA2			DA4		
			Efficiency (dB)	Efficiency (%)	Gain (dBi)	Efficiency (dB)	Efficiency (%)	Gain (dBi)	Efficiency (dB)	Efficiency (%)	Gain (dBi)	Efficiency (dB)	Efficiency (%)	Gain (dBi)
LTE Band 71	TX	663												
		680.5												
		698												
LTE Band 71	RX	617												
		634.5									-6.8	21.0	-2.3	
		652										-6.6	22.0	-1.8
LTE Band 12	TX	699												
		707												
		716												
LTE Band 12	RX	729												
		737												
		746										-4.3	37.3	0.6
LTE Band 5	TX	824												
		836												
		849												
LTE Band 5	RX	869												
		880												
		894												
LTE Band 66	TX	1710												
		1745												
		1780												
LTE Band 66	RX	2110												
		2155												
		2200												
LTE Band 2	TX	1850												
		1880												
		1910												
LTE Band 2	RX	1930												
		1960												
		1990												
LTE Band 25	TX	1850												
		1883												
		1915												
LTE Band 25	RX	1930												
		1963												
		1995												
LTEB41	TX/RX	2496												
		2593												
		2690												
LTEB48	TX/RX	3550	-2.7	53.5	1.9	-2.9	51.3	1.7	-3.6	43.2	4.3	-4.5	35.1	4.5
		3625	-2.4	56.9	1.9	-2.6	55.2	1.8	-3.2	48.3	4.4	-4.2	38.1	4.7
		3700	-2.1	61.0	2.0	-2.2	60.1	2.0	-2.8	52.7	4.4	-3.4	45.5	4.6
LTE n77	TX/RX	3300	-1.7	68.3	1.7	-2.5	55.7	1.6	-3.1	49.3	4.1	-4.4	36.7	4.2
		3750	-2.2	60.3	2.1	-2.3	58.4	2.2	-2.2	59.8	4.6	-3.4	45.8	4.7
		4200	-2.7	54.0	2.0	-2.2	60.7	1.9	-1.8	65.7	4.2	-4.5	35.1	4.2

# Peak Gain & Efficiency

Frequency (MHz)	WIFI 0			WIFI 1			WIFI 2			WIFI 3		
	Efficiency (dB)	Efficiency (%)	Gain (dBi)	Efficiency (dB)	Efficiency (%)	Gain (dBi)	Efficiency (dB)	Efficiency (%)	Gain (dBi)	Efficiency (dB)	Efficiency (%)	Gain (dBi)
2400	-2.3	58.3	3.8	-2.8	52.1	2.4	-2.9	51.4	1.5	-2.5	56.8	3.1
2450	-2.5	56.5	3.6	-2.5	56.1	2.0	-2.9	50.8	1.6	-1.7	67.9	3.3
2500	-2.7	53.3	3.2	-2.3	59.5	2.7	-3.0	50.2	2.6	-1.6	69.3	3.1
5150	-2.6	55.1	3.4	-2.8	52.6	2.1	-2.9	50.9	3.2	-2.7	53.6	2.5
5500	-2.4	58.1	3.9	-2.9	51.3	1.7	-2.9	50.8	3.4	-2.4	56.9	2.5
5850	-2.5	55.9	3.8	-2.9	51.9	1.9	-2.9	51.2	3.6	-2.4	57.3	1.9
1575												

Frequency (MHz)	GPS			BT		
	Efficiency (dB)	Efficiency (%)	Gain (dBi)	Efficiency (dB)	Efficiency (%)	Gain (dBi)
2400				-3.6	43.6	1.2
2450				-3.4	45.5	1.6
2500				-3.4	45.8	1.7
5150						
5500						
5850						
1575	-2.5	56.5	4.8			



# Envelope Correlation Coefficient (ECC)\_Low Band

n71 ECC TMO Spec < 0.5					
	Ant 0	Ant 1	Ant 3	Ant 4	DA4
Ant 0					
Ant 1	0.342				
Ant 3	0.358	0.369			
Ant 4	0.322	0.359	0.377		
DA4	0.365	0.287	0.299	0.325	

B12 ECC TMO Spec < 0.5					
	Ant 1	Ant 2	Ant 3	Ant 4	DA4
Ant 1					
Ant 2	0.321				
Ant 3	0.295	0.303			
Ant 4	0.324	0.312	0.343		
DA4	0.288	0.379	0.284	0.361	

# Envelope Correlation Coefficient (ECC)\_Middle Band

B2/B25/n2/n25 ECC TMO Spec < 0.2						
	Ant 1	Ant 2	Ant 3	Ant 4	DA2	DA4
Ant 1						
Ant 2	0.120					
Ant 3	0.144	0.152				
Ant 4	0.151	0.149	0.129			
DA2	0.136	0.138	0.117	0.124		
DA4	0.111	0.157	0.102	0.168	0.121	

B66/n66 ECC TMO Spec < 0.2						
	Ant 1	Ant 2	Ant 3	Ant 4	DA2	DA4
Ant 1						
Ant 2	0.109					
Ant 3	0.162	0.114				
Ant 4	0.123	0.158	0.123			
DA2	0.100	0.162	0.112	0.117		
DA4	0.112	0.145	0.107	0.167	0.111	

# Envelope Correlation Coefficient (ECC)\_High Band

B41/n41 ECC TMO Spec < 0.2						
	Ant 1	Ant 2	Ant 3	Ant 4	DA2	DA4
Ant 1						
Ant 2	0.098					
Ant 3	0.126	0.109				
Ant 4	0.106	0.136	0.121			
DA2	0.137	0.164	0.131	0.110		
DA4	0.101	0.155	0.109	0.161	0.103	



# Envelope Correlation Coefficient (ECC)\_Ultra High Band

B48/n48/n77 ECC TMO Spec < 0.2						
	Ant 2	Ant 4	Ant 5	Ant 6	DA2	DA4
Ant 2						
Ant 4	0.102					
Ant 5	0.111	0.124				
Ant 6	0.085	0.128	0.132			
DA2	0.116	0.125	0.137	0.118		
DA4	0.100	0.112	0.131	0.129	0.153	

**SERCOMM**

[www.sercomm.com](http://www.sercomm.com)