

APPLICATION OF CERTIFICATION
For

Mad Catz, Inc.

Eclipse Wireless Litetouch Keyboard (Dongle)

Model Number: ECB43001

FCC ID: P25M043001C1011R

Prepared for : Mad Catz, Inc.
7480 Mission Valley Road, Suite 101, San Diego, California,
92108

Prepared By: Audix Technology (Shenzhen) Co., Ltd.
No. 6, Ke Feng Rd., 52 Block,
Shenzhen Science & Industrial Park,
Nantou, Shenzhen, Guangdong, China

Tel: (0755) 26639496

Fax: (0755) 26632877

Report Number : ACS-F10050

Date of Test : Feb.11, 2010

Date of Report : Mar.18, 2010

TABLE OF CONTENTS

Description	Page
1. SUMMARY OF STANDARDS AND RESULTS	1-1
1.1. Description of Standards and Results	1-1
2. GENERAL INFORMATION.....	2-1
2.1. Description of Device (EUT).....	2-1
2.2. Tested Supporting System Details	2-1
2.3. Test Facility	2-2
2.4. Measurement Uncertainty (95% confidence levels, k=2).....	2-2
3. POWER LINE CONDUCTED EMISSION TEST	3-1
3.1. Test Equipment.....	3-1
3.2. Block Diagram of Test Setup.....	3-1
3.3. Power Line Conducted Emission Test Limits	3-1
3.4. Configuration of EUT on Test.....	3-2
3.5. Operating Condition of EUT	3-2
3.6. Test Procedure	3-2
3.7. Conducted Disturbance at Mains Terminals Test Results	3-2
4. RADIATED EMISSION TEST.....	4-1
4.1. Test Equipment.....	4-1
4.2. Block Diagram of Test Setup.....	4-1
4.3. Radiated Emission Limit	4-2
4.4. EUT Configuration on Test	4-2
4.5. Operating Condition of EUT	4-2
4.6. Test Procedure	4-2
4.7. Radiated Disturbance Test Results	4-3
5. DEVIATION TO TEST SPECIFICATIONS	5-1
6. PHOTOGRAPH	6-1
6.1. Photos of Power Line Conducted Emission Test.....	6-1
6.2. Photos of Radiated Emission Test (In Anechoic Chamber)	6-2
7. PHOTOS OF THE EUT	7-1

TEST REPORT CERTIFICATION

Applicant : Mad Catz, Inc.
 EUT Description : Eclipse Wireless Litetouch Keyboard (Dongle)
 Model Number : ECB43001
 FCC ID : P25M043001C1011R
 Power Supply : DC 5V
 Test Voltage : DC 5V From Notebook Input AC 120V/60Hz

Measurement Standard Used:

FCC Rules and Regulations Part 15 Subpart B Class B 2008, ANSI C63.4-2003

The device described above is tested by Audix Technology (Shenzhen) Co., Ltd. to determine the maximum emission levels emanating from the device. The maximum emission levels are compared to the FCC Part 15 Subpart B Class B limits for radiated and conducted emissions. The test results are contained in this test report and Audix Technology (Shenzhen) Co., Ltd. is assumed full responsibility for the accuracy and completeness of tests. Also, this report shows that EUT is technically compliant with FCC requirements.

This report applies to above tested sample only. This report shall not be reproduced in parts without written approval of AUDIX TECHNOLOGY (SHENZHEN) CO., LTD.

Date of Test: Feb.11, 2010

Prepared by:

Edie Huang
 Edie Huang / Assistant

Reviewer:

Jamy Yu
 Jamy Yu / Supervisor

Approved & Authorized Signer:



Ken Lu / Manager

1. SUMMARY OF STANDARDS AND RESULTS

1.1. Description of Standards and Results

The EUT have been tested according to the applicable standards as referenced below.

EMISSION			
Description of Test Item	Standard	Limits	Results
Power Line Conducted Emission Test	FCC Part 15: 2008 ANSI C63.4: 2003	Class B	PASS
Radiated Emission Test	FCC Part 15: 2008 ANSI C63.4: 2003	Class B	PASS

2. GENERAL INFORMATION

2.1. Description of Device (EUT)

EUT Description : Eclipse Wireless Litetouch Keyboard (Dongle)

Model Number : ECB43001

FCC ID : P25M043001C1011R

Operation Frequency : 2405MHz~2480MHz

Applicant : Mad Catz, Inc.
7480 Mission Valley Road, Suite 101, San Diego,
California, 92108

Date of Test : Feb.11, 2010

Date of Receipt : Jan.10, 2010

Sample Type : Prototype production

2.2. Tested Supporting System Details

2.2.1. Notebook

M/N : PP09S

S/N : N/A

Manufacturer : DELL

Power Adaptor : Manufacturer: DELL,
M/N: LA65NS1-00
Cable: Unshielded, Detachable, 4.0m
(Bond one ferrite core)

2.2.2. Keyboard

M/N : ECB43001

Manufacturer : Mad Catz, Inc.

Power Adapter : Manufacturer: Mass Power
M/N: SDF0500150A1B13
Cable: Shielded, Undechangeable, 1.5m
(with one core)

2.3. Test Facility

Site Description	
Name of Firm	: Audix Technology (Shenzhen) Co., Ltd. No. 6, Ke Feng Rd., 52 Block, Shenzhen Science & Industrial Park, Nantou, Shenzhen, Guangdong, China
3m Anechoic Chamber	: Mar. 31, 2009 File on Federal Communication Commission Registration Number: 90454
3m & 10m Anechoic Chamber	: Dec. 30, 2009 File on Federal Communication Commission Registration Number: 794232
EMC Lab.	: Accredited by DATech, German Registration Number: DAT-P-091/99-01 Feb. 02, 2009 Accredited by NVLAP, USA NVLAP Code: 200372-0 Apr. 01, 2009

2.4. Measurement Uncertainty (95% confidence levels, k=2)

Test Item	Uncertainty
Uncertainty for Conduction emission test in No. 1 Conduction	2.40dB
Uncertainty for Radiation Emission test in 3m chamber	3.82 dB (Polarize: V)
	4.32 dB (Polarize: H)
Uncertainty for DC power test	0.038 %
Uncertainty for test site temperature and humidity	0.6°C
	3%

3. POWER LINE CONDUCTED EMISSION TEST

3.1. Test Equipment

Item	Equipment	Manufacturer	Model No.	Serial No.	Last Cal.	Cal. Interval
1	Test Receiver	Rohde & Schwarz	ESHS20	836600/006	May.08, 09	1 Year
2	L.I.S.N.#1	Rohde & Schwarz	ESH2-Z5	834066/011	May.08, 09	1 Year
3	L.I.S.N.#2	Kyoritsu	KNW-407	8-1636-1	May.08, 09	1 Year
4	Terminator	Hubersuhner	50Ω	No. 1	May.08, 09	1 Year
5	RF Cable	Fujikura	3D-2W	LISN Cable 1#	May.08, 09	1Year
6	Coaxial Switch	Anritsu	MP59B	M55367	May.08, 09	1 Year
7	Pulse Limiter	Rohde & Schwarz	ESH3-Z2	100341	May.08, 09	1 Year

3.2. Block Diagram of Test Setup

3.2.1. Block diagram of connection between the EUT and simulators

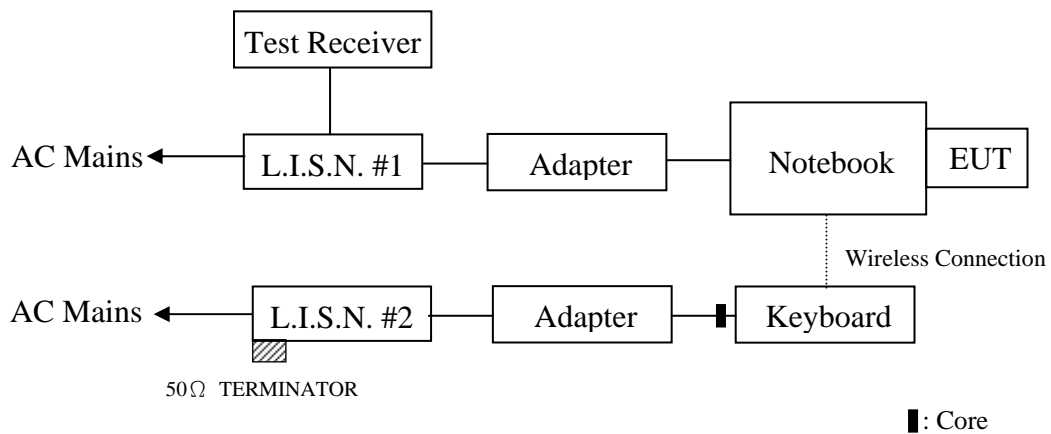

(EUT: Eclipse Wireless Litetouch Keyboard (Dongle))

3.3. Power Line Conducted Emission Test Limits

Frequency	Maximum RF Line Voltage	
	Quasi-Peak Level dB(μV)	Average Level dB(μV)
150kHz ~ 500kHz	66 ~ 56*	56 ~ 46*
500kHz ~ 5MHz	56	46
5MHz ~ 30MHz	60	50

Notes: 1. * Decreasing linearly with logarithm of frequency.

2. The lower limit shall apply at the transition frequencies.

3.4. Configuration of EUT on Test

The following equipment are installed on Power Line Conducted Emission Test to meet the commission requirement and operating regulations in a manner which tends to maximize its emission characteristics in a normal application.

3.4.1. Eclipse Wireless Litetouch Keyboard (Dongle) (EUT)

Model Number : ECB43001
Serial Number : N/A

3.4.2. Support Equipment : As Tested Supporting System Detail, in Section 2.2.

3.5. Operating Condition of EUT

3.5.1. Setup the EUT and simulator as shown as Section 3.2.

3.5.2. Turn on the power of all equipment.

3.5.3. Let the EUT worked in test mode (Tx Mode) and measured it.

3.6. Test Procedure

The EUT was placed on a non-metallic table, 80cm above the ground plane. The EUT Power connected to the power mains through a line impedance stabilization network (L.I.S.N. 1#). This provided a 50-ohm coupling impedance for the EUT (Please refer to the block diagram of the test setup and photographs). The other peripheral devices power cord connected to the power mains through a line impedance stabilization network (L.I.S.N.#2). Both sides of power line were checked for maximum conducted interference. In order to find the maximum emission, the relative positions of equipments and all of the interface cables were changed according to ANSI C63.4-2003 on conducted Emission test.

The bandwidth of test receiver (R&S TEST RECEIVER ESHS20) is set at 10kHz.

The frequency range from 150kHz to 30MHz is checked. The test result are reported on Section 3.7.

3.7. Conducted Disturbance at Mains Terminals Test Results

PASS. (All emissions not reported below are too low against the prescribed limits.)

The EUT with the following test mode was tested and selected (mode 1) to read Q.P values and Average values, all the test results are listed in next pages.

EUT: Eclipse Wireless Litetouch Keyboard (Dongle) Model No. : ECB43001

Test Date: Feb.11, 2010 Temperature: 23°C Humidity: 54%

The details of test mode are as follows :

NO.	Test Mode	Reference Test Data No.	
		VA	VB
1.	Tx Mode	#4	#3



NO.6 Ke Feng Road,Block 52,
Shenzhen Science&Industry Park
Nantou, Shenzhen,Guang dong, China.
Tel:+86-755-26639495
Fax:+86-755-26632877
Postcode:518057

Data: 4 File: D:\DATA\2010 test data\MMAD CATZ\ACS9QH357.EM6 (8)

Date: 2010-02-11

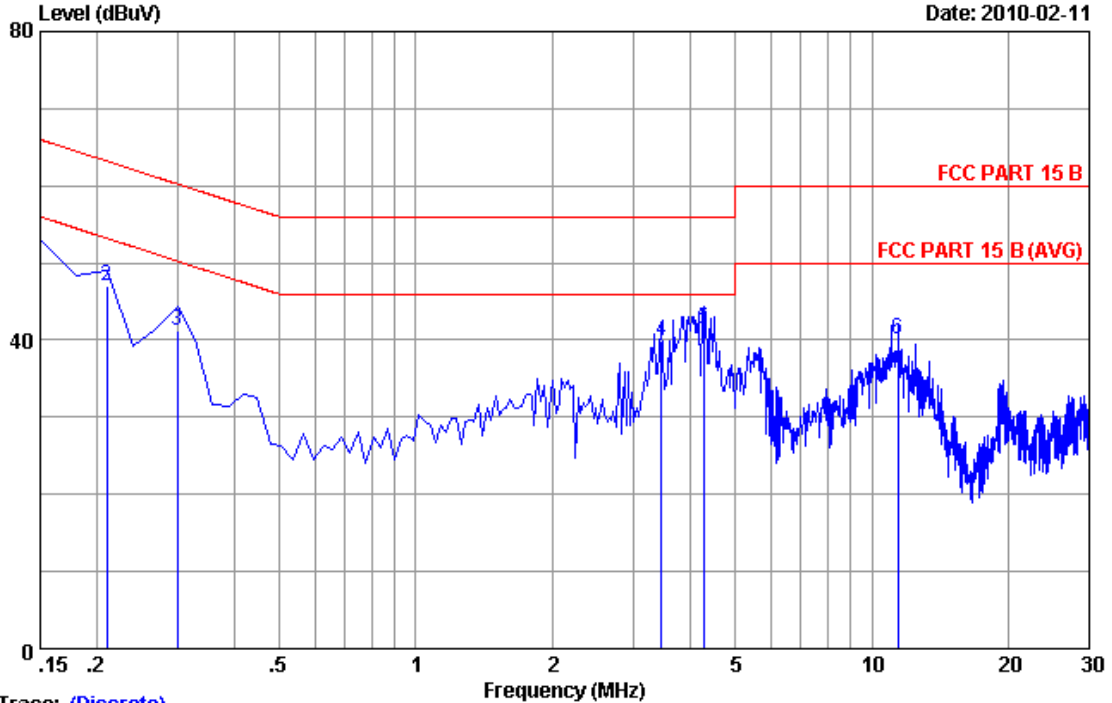

Trace: (Discrete)

Site no :Audix No.1 Conduction Data no :4
 Dis./Ant. **: 2009 KNW-242C VA
 Limit :FCC PART 15 B
 Env./Ins. :Temp:23'C Humi:54% Engineer :Power Feng
 EUT :Eclipse Wireless Litetouch Keyboard (Dongle)
 Power Rating :DC 5V From Notebook Input AC 120V/60Hz
 Test Mode :Tx Mode
 ECB43001

No	Freq (MHz)	LISN Factor (dB)	Cable Loss (dB)	Reading (dBuV)	Emission Level (dBuV)	Limits (dBuV)	Margin (dB)	Remark
1	0.15000	0.09	9.88	40.00	49.97	66.00	16.03	QP
2	0.20970	0.08	9.88	37.02	46.98	63.22	16.24	QP
3	0.29925	0.07	9.88	31.39	41.34	60.26	18.92	QP
4	3.463	0.10	9.91	29.86	39.87	56.00	16.13	QP
5	4.269	0.11	9.91	31.35	41.37	56.00	14.63	QP
6	11.433	0.21	9.95	29.86	40.02	60.00	19.98	QP

Remarks: 1.Emission Level=LISN Factor+Cable Loss+Reading.
 2.If the average limit is met when using a quasi-peak detector. the EUT shall be deemed to meet both limits and measurement with average detector is unnecessary.



NO.6 Ke Feng Road,Block 52,
Shenzhen Science&Industry Park
Nantou, Shenzhen,Guang dong, China.
Tel:+86-755-26639495
Fax:+86-755-26632877
Postcode:518057

Data: 3 File: D:\DATA\2010 test data\MMAD CATZ\ACS9QH357.EM6 (8)

Date: 2010-02-11

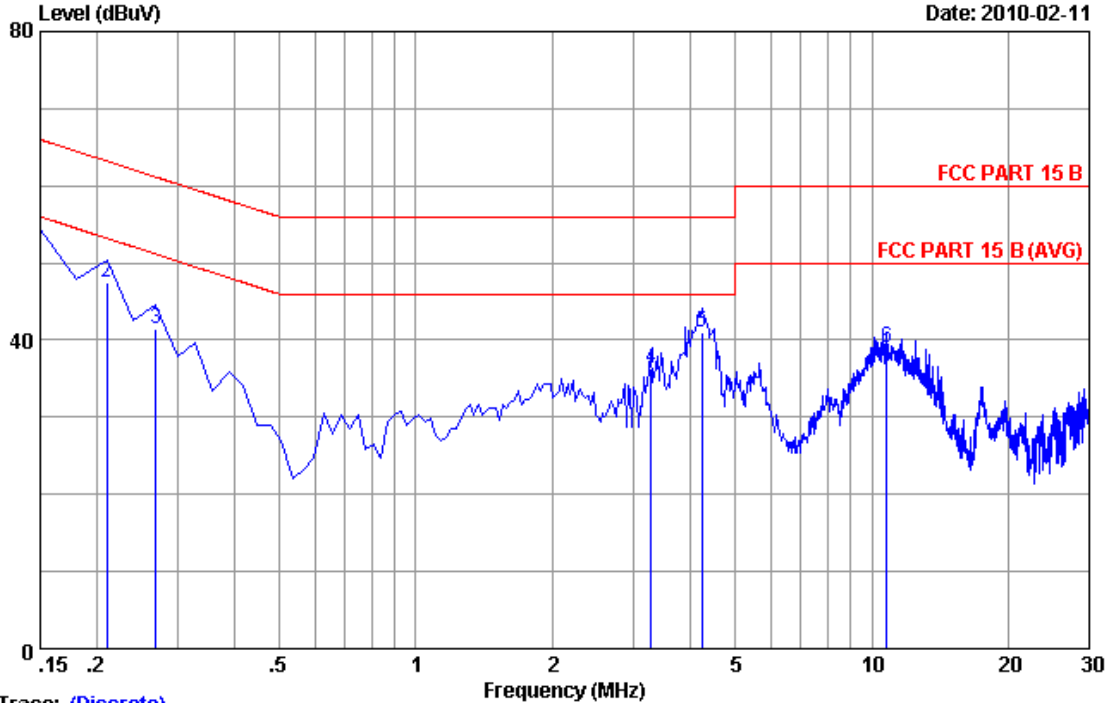

Trace: (Discrete)

Site no :Audix No.1 Conduction Data no :3
 Dis./Ant. **: 2009 KNW-242C VB
 Limit :FCC PART 15 B
 Env./Ins. :Temp:23'C Humi:54% Engineer :Power Feng
 EUT :Eclipse Wireless Litetouch Keyboard (Dongle)
 Power Rating :DC 5V From Notebook Input AC 120V/60Hz
 Test Mode :Tx Mode
 ECB43001

No	Freq (MHz)	LISN Factor (dB)	Cable Loss (dB)	Reading (dBuV)	Emission Level (dBuV)	Limits (dBuV)	Margin (dB)	Remark
1	0.15000	0.62	9.88	40.89	51.39	66.00	14.61	QP
2	0.20970	0.07	9.88	37.51	47.46	63.22	15.76	QP
3	0.26940	0.09	9.88	31.55	41.52	61.14	19.62	QP
4	3.284	0.38	9.91	25.93	36.22	56.00	19.78	QP
5	4.239	0.41	9.91	30.73	41.05	56.00	14.95	QP
6	10.806	0.51	9.94	28.49	38.94	60.00	21.06	QP

Remarks: 1.Emission Level=LISN Factor+Cable Loss+Reading.
 2.If the average limit is met when using a quasi-peak detector. the EUT shall be deemed to meet both limits and measurement with average detector is unnecessary.

4. RADIATED EMISSION TEST

4.1. Test Equipment

Item	Equipment	Manufacturer	Model No.	Serial No.	Last Cal.	Cal. Interval
1	3#Chamber	AUDIX	N/A	N/A	Dec.05,09	1 Year
2	EMI Spectrum	Agilent	E4407B	MY41440292	May.08, 09	1 Year
3	Test Receiver	Rohde & Schwarz	ESVS10	834468/011	May.08, 09	1 Year
4	Amplifier	HP	8447D	2648A04738	May.08, 09	1 Year
5	Bilog Antenna	Schaffner	CBL6111C	2598	Dec.14, 09	1 Year
6	RF Cable	MIYAZAKI	8D-FB	3# Chamber No.1	May.08, 09	1 Year
7	Coaxial Switch	Anritsu	MP59B	M73989	May.08, 09	1 Year

4.2. Block Diagram of Test Setup

4.2.1. Block diagram of connection between the EUT and simulators

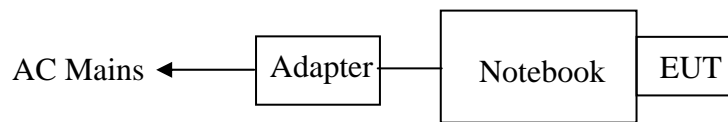

(EUT: Eclipse Wireless Litetouch Keyboard (Dongle))

4.2.2. In Anechoic Chamber

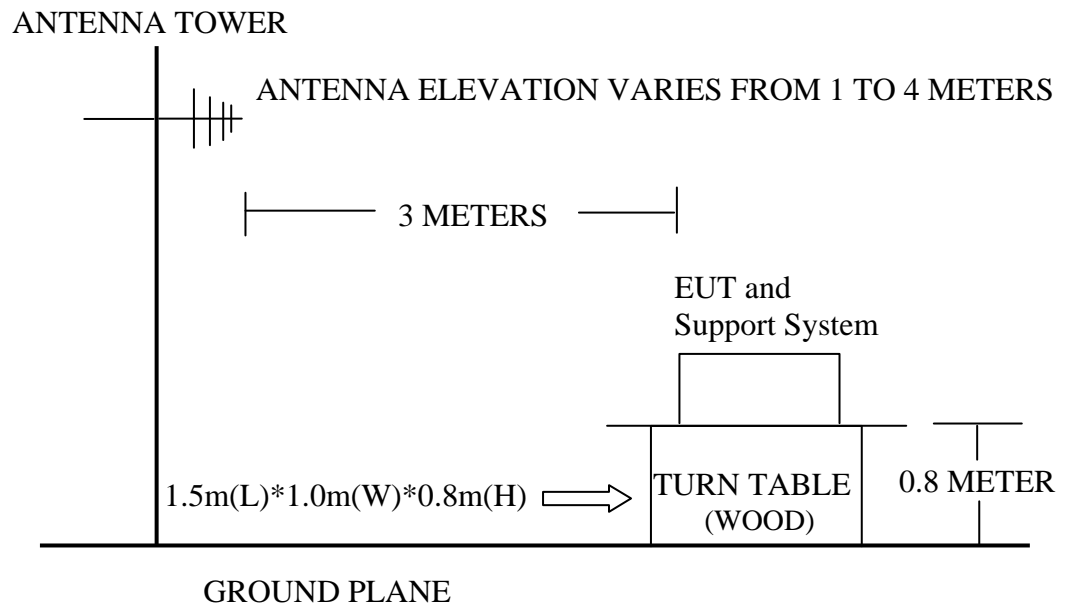

4.3. Radiated Emission Limit

FREQUENCY MHz	DISTANCE Meters	FIELD STRENGTHS LIMIT
		dB(μ V)/m
30 ~ 88	3	40.0
88 ~ 216	3	43.5
216 ~ 960	3	46.0
960 ~ 1000	3	54.0

- Remark: (1) Emission level = Antenna Factor + Cable Loss + Reading
 (2) The smaller limit shall apply at the cross point between two frequency bands.
 (3) Distance is the distance in meters between the measuring instrument, antenna and the closest point of any part of the device or system.

4.4. EUT Configuration on Test

The following equipment are installed on Radiated Emission Test to meet the commission requirements and operating regulations in a manner that tends to maximize its emission characteristics in normal application.

4.4.1. Eclipse Wireless Litetouch Keyboard (Dongle) (EUT)

Model Number : ECB43001
 Serial Number : N/A

4.4.2. Support Equipment : As Tested Supporting System Detail, in Section 2.2.

4.5. Operating Condition of EUT

4.5.1. Setup the EUT as shown in Section 4.2.

4.5.2. Turn on the power of all equipment.

4.5.3. Let the EUT worked in test mode (Tx Mode) and tested it.

4.6. Test Procedure

The EUT was placed on a turn table, which is 0.8 meter high above ground. An antenna was located 3m from the EUT on an adjustable mast. A pre-scan was first performed in order to find prominent radiated emissions. For final emissions measurements at each frequency of interest, the EUT were rotated and the antenna height was varied between 1m and 4m in order to maximize the emission. Measurements in both horizontal and vertical polarities were made and the data was recorded. In order to find the maximum emission, the relative positions of equipments and all of the interface cables were changed according to ANSI C63.4-2003 on Radiated Emission test.

The bandwidth setting on the test receiver (R&S TEST RECEIVER ESVS10) is 120 kHz.

The frequency range from 30MHz to 1000MHz is checked. The test results are reported on Section 4.7.

4.7. Radiated Disturbance Test Results

PASS. (All emissions not reported below are too low against the prescribed limits.)

The EUT with the following test mode was tested and selected (mode 1) to read Q.P values, all the test results are listed in next pages.

EUT: Eclipse Wireless Litetouch Keyboard (Dongle) Model No. : ECB43001

Test Date: Feb.11, 2010 Temperature: 24°C Humidity: 56%

The details of test mode are as follows :

NO.	Test Mode	Reference Test Data No.	
		Horizontal	Vertical
1.	Tx Mode	#1	#2

For above 1GHz frequency

Due to the EUT's highest frequency generated and the highest frequency below 108MHz , therefore the above 1GHz frequency is no need to measurement.



No.6 Ke Feng Road,Block 52,
ShenZhen Science & Industry Park
Noutou,ShenZhen,GuangDong,China
Tel:+86-755-26639495-7
Fax:+86-755-26632877
Postcode:518057

Data: 1 File: D:\2010 Reput Data\W\ACS9QH357.EM6 (4)

Date: 2010-02-11

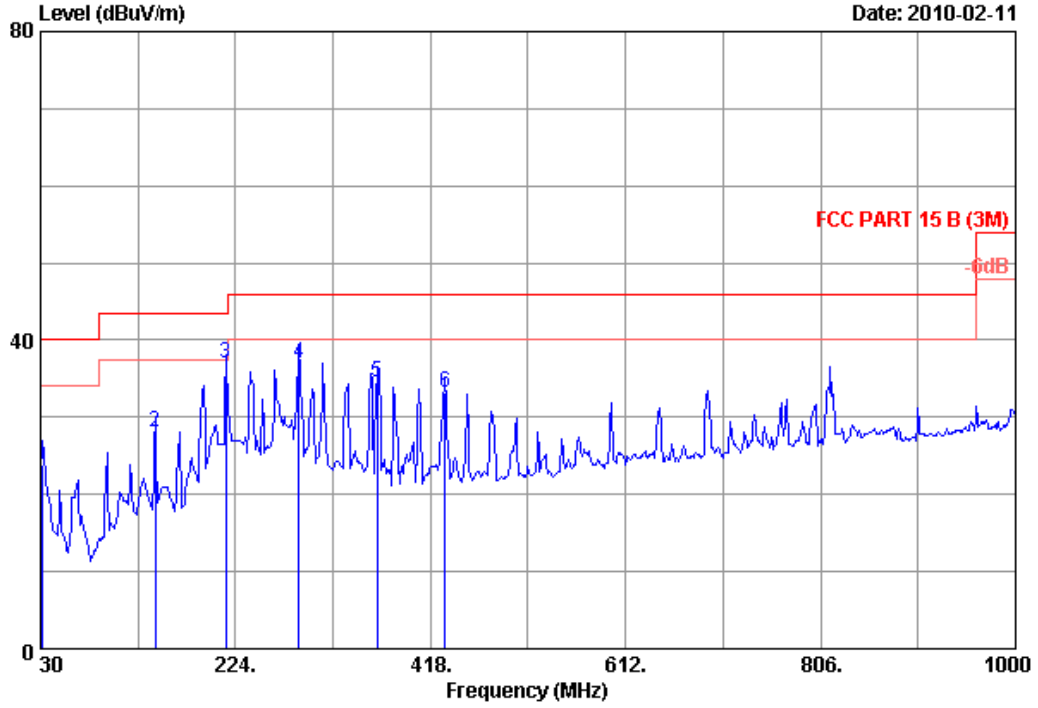

Site no. : 3m chamber Data no. : 1
 Dis. / Ant. : 3m CBL6111C Ant. pol. : HORIZONTAL
 Limit : FCC PART 15 B (3M)
 Env. / Ins. : 24°C/56% Engineer : Power Feng
 EUT : Eclipse Wireless Litetouch Keyboard (Dongle)
 Power Rating : DC 5V From Notebook Input AC 120V/60Hz
 Test Mode : Tx mode
 M/N : ECB43001

No.	Freq. (MHz)	Ant. Factor (dB/m)	Cable Loss (dB)	Reading (dBuV)	Emission Level (dBuV/m)	Limits (dBuV/m)	Margin (dB)	Remark
1	31.940	18.73	0.53	4.67	23.93	40.00	16.07	QP
2	144.460	11.78	1.07	15.13	27.98	43.50	15.52	QP
3	214.300	9.98	1.40	25.55	36.93	43.50	6.57	QP
4	287.050	13.34	1.71	21.88	36.93	46.00	9.07	QP
5	364.650	15.38	1.86	17.41	34.65	46.00	11.35	QP
6	432.550	16.90	2.03	14.23	33.16	46.00	12.84	QP

Remarks: 1. Emission Level= Antenna Factor + Cable Loss + Reading.
 2. The emission levels that are 20dB below the official limit are not reported.
 3. The worst emission was detected at 214.300MHz with corrected signal level of 36.93dBμV/m (Limit is 43.50dBμV/m) when the antenna was at horizontal polarization and at 2.0m high and the turn table was at 145°.
 4. 0° was the table front facing the antenna. Degree is calculated from 0° clockwise facing the antenna.



No.6 Ke Feng Road,Block 52,
ShenZhen Science & Industry Park
Noutou,ShenZhen,GuangDong,China
Tel:+86-755-26639495-7
Fax:+86-755-26632877
Postcode:518057

Data: 2

File: D:\2010 Reput Data\W\ACS9QH357.EM6 (4)

Date: 2010-02-11

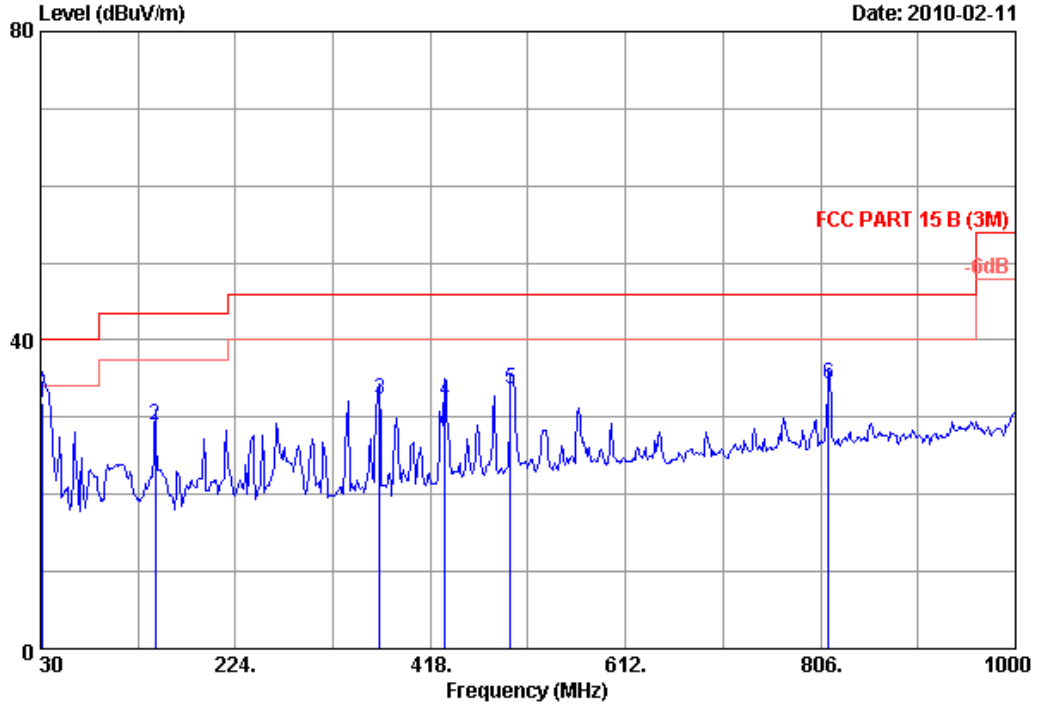

Site no. : 3m chamber
Dis. / Ant. : 3m CBL6111C
Limit : FCC PART 15 B (3M)
Env. / Ins. : 24°C/56%
EUT : Eclipse Wireless Litetouch Keyboard (Dongle)
Power Rating : DC 5V From Notebook Input AC 120V/60Hz
Test Mode : Tx mode
M/N : ECB43001

Data no. : 2
Ant. pol. : VERTICAL
Engineer : Power Feng

No.	Freq. (MHz)	Ant. Factor (dB/m)	Cable Loss (dB)	Reading (dBuV)	Emission Level (dBuV/m)	Limits (dBuV/m)	Margin (dB)	Remark
1	31.940	18.73	0.53	12.54	31.80	40.00	8.20	QP
2	144.460	11.78	1.07	16.16	29.01	43.50	14.49	QP
3	367.560	15.41	1.87	14.95	32.23	46.00	13.77	QP
4	432.550	16.90	2.03	13.13	32.06	46.00	13.94	QP
5	497.540	17.99	2.24	13.45	33.68	46.00	12.32	QP
6	813.760	21.88	3.07	9.39	34.34	46.00	11.66	QP

- Remarks:
1. Emission Level= Antenna Factor + Cable Loss + Reading.
 2. The emission levels that are 20dB below the official limit are not reported.
 3. The worst emission was detected at 31.940MHz with corrected signal level of 31.80dBμV/m (Limit is 40.00dBμV/m) when the antenna was at vertical polarization and at 1.0m high and the turn table was at 310°.
 4. 0° was the table front facing the antenna. Degree is calculated from 0° clockwise facing the antenna.

5. DEVIATION TO TEST SPECIFICATIONS

[NONE]