



FCC ID:P25H890977R

AUDIX Technology (Shenzhen) Co., Ltd.

FCC PART 15C TEST REPORT FOR CERTIFICATION

On Behalf of

Mad Catz, Inc.

Katana HD 7.1 Base Station Receiver

Model No.: 90977R

FCC ID: P25H890977R

Prepared for : Mad Catz, Inc.

10680 Treena Street Suite 500 San Diego, CA 92131

Prepared By : Audix Technology (Shenzhen) Co., Ltd.

No. 6, Ke Feng Rd., 52 Block,
Shenzhen Science & Industrial Park,
Nantou, Shenzhen, Guangdong, China

Tel: (0755) 26639496

Report Number : ACS-F16077

Date of Test : Dec.28, 2015~Mar.23, 2016

Date of Report : Apr.01, 2016

TABLE OF CONTENTS

<u>Description</u>	<u>Page</u>
1. SUMMARY OF STANDARDS AND RESULTS	1-1
1.1. Description of Standards and Results	1-1
2. GENERAL INFORMATION	2-1
2.1. Description of Device (EUT)	2-1
2.2. Tested Supporting System Details	2-2
2.3. Block diagram of connection between the EUT and simulators	2-2
2.4. Test information	2-3
2.5. Test Facility	2-4
2.6. Measurement Uncertainty (95% confidence levels, k=2)	2-4
3. POWER LINE CONDUCTED EMISSION TEST	3-1
3.1. Test Equipments	3-1
3.2. Block Diagram of Test Setup	3-1
3.3. Power Line Conducted Emission Test Limits	3-1
3.4. Configuration of EUT on Test	3-1
3.5. Operating Condition of EUT	3-2
3.6. Test Procedure	3-2
3.7. Power Line Conducted Emission Test Results	3-2
4. RADIATED EMISSION MEASUREMENT	4-1
4.1. Test Equipment	4-1
4.2. Block Diagram of Test Setup	4-2
4.3. Radiated Emission Limit Standard:	4-3
4.4. EUT Configuration on Test	4-3
4.5. Operating Condition of EUT	4-3
4.6. Test Procedure	4-3
4.7. Radiated Emission Test Results	4-4
5. CONDUCTED SPURIOUS EMISSIONS	5-1
5.1. Test Equipment	5-1
5.2. Limit	5-1
5.3. Test Procedure	5-1
5.4. Test result	5-1
6. 6dB BANDWIDTH TEST	6-1
6.1. Test Equipment	6-1
6.2. Limit	6-1
6.3. Test Procedure	6-1
6.4. Test Results	6-1
7. MAXIMUM PEAK OUTPUT POWER TEST	7-1
7.1. Test Equipment	7-1
7.2. Limit	7-1
7.3. Test Procedure	7-1
7.4. Test Results	7-1
8. BAND EDGE COMPLIANCE TEST	8-1
8.1. Test Equipment	8-1
8.2. Limit	8-1
8.3. Test Produce	8-1
8.4. Test Results	8-1

9.	POWER SPECTRAL DENSITY TEST	9-1
9.1.	Test Equipment	9-1
9.2.	Limit.....	9-1
9.3.	Test Procedure.....	9-1
9.4.	Test Results	9-1
10.	ANTENNA REQUIREMENT	10-1
10.1.	STANDARD APPLICABLE.....	10-1
10.2.	ANTENNA CONNECTED CONSTRUCTION	10-1
11.	DEVIATION TO TEST SPECIFICATIONS.....	11-1
12.	HOTOGRAPH OF TEST	12-1
12.1.	Photos of Power Line Conducted Emission Test.....	12-1
12.2.	Photos of Radiated Emission Test.....	12-2
13.	PHOTOS OF THE EUT.....	13-1

TEST REPORT CERTIFICATION

Applicant : Mad Catz, Inc.
 Manufacture : Mad Catz, Inc.
 EUT Description : Katana HD 7.1 Base Station Receiver
 FCC ID : P25H890977R
 (A) Model No. : 90977R
 (B) Power Supply : DC 5V
 (C) Test Voltage : DC 5V From PC Input AC 120V/60Hz

Tested for comply with:

FCC CFR 47 Part 15 Subpart C: 2014
 Test procedure used: ANSI C63.10: 2013;
 KDB558074 D01 v03r04

The device described above is tested by AUDIX TECHNOLOGY (SHENZHEN) CO., LTD. to confirm comply with all the FCC Part 15 Subpart C requirements. The test results are contained in this test report and AUDIX TECHNOLOGY (SHENZHEN) CO., LTD. is assumed full responsibility for the accuracy and completeness of these tests. Also, this report shows that the Equipment Under Test (EUT) is to be technically compliant with the FCC requirements. This report contains data that are not covered by the NVLAP accreditation.

This Report is made under FCC Part 2.1075. No modifications were required during testing to bring this product into compliance.

This report applies to above tested sample only. This report shall not be reproduced in part without written approval of AUDIX TECHNOLOGY (SHENZHEN) CO., LTD.

The report must not be used by the client to claim product certification, approval, or endorsement by NVLAP, NIST, or any agency of the federal government.

Date of Test : Dec.28, 2015~Mar.23, 2016 Report of date: Apr.01, 2016

Prepared by : Cindy Zhu / Assistant Reviewed by : Sunny Lu / Assistant Manager



Approved & Authorized Signer :

1. SUMMARY OF STANDARDS AND RESULTS

1.1. Description of Standards and Results

The EUT have been tested according to the applicable standards as referenced below.

EMISSION		
Description of Test Item	Standard	Results
Power Line Conducted Emission Test	FCC Part 15: 15.207 ANSI C63.10 :2013	PASS
Radiated Emission Test	FCC Part 15: 15.209 FCC Part 15: 15.247(d) ANSI C63.10 : 2013	PASS
Conducted Spurious Emissions	FCC Part 15: 15.247(a)(1) ANSI C63.10 : 2013	PASS
Carrier Frequency Separation Test	FCC Part 15: 15.247(a)(1) ANSI C63.10 : 2013	PASS
6dB Bandwidth Test	FCC Part 15: 15.215 ANSI C63.10 : 2013	PASS
Maximum Peak Output Power Test	FCC Part 15: 15.247(b)(1) ANSI C63.10 : 2013	PASS
Band Edge Compliance Test	FCC Part 15: 15.247(d) ANSI C63.10 : 2013	PASS
Power Spectral Density Test	FCC Part 15: 15.247(d) ANSI C63.10 : 2013	PASS

2. GENERAL INFORMATION

2.1. Description of Device (EUT)

Product Name : Katana HD 7.1 Base Station Receiver

Model Number : 90977R

FCC ID : P25H890977R

Radio : 2.4GHz Wireless

Operation frequency : 2406MHz-2474MHz

Antenna : Integrated PCB Antenna, 3.7874dBi PK gain

Modulation : GFSK

Applicant : Mad Catz, Inc.
10680 Treena Street Suite 500 San Diego, CA 92131

Manufacturer : Mad Catz, Inc.
10680 Treena Street Suite 500 San Diego, CA 92131

Audio Cable : Unshielded, Detachable; 0.9m

USB Cable : Shielded, Detachable; 1m

HDMI Cable : Shielded, Detachable; 1m

Date of Test : Dec.28, 2015~Mar.23, 2016

Date of Receipt : Dec.26, 2015

Sample Type : Prototype production

2.2. Tested Supporting System Details

No.	Description	ACS No.	Manufacturer	Model	Serial Number
1.	Notebook	N/A	SONY	SVF143A1QT	N/A
		Power Adapter: Manufacturer: SONY, Model: VGP-AC19V77 Input: 100-240V~, 1.5A, 50/60Hz Output: 19.5V----3.3A Power Cord: Unshielded, Detachable, 1.8m			
2.	Monitor	--	Lenovo	L2361pwA	--
		Power Cord: Unshielded, Detachable, 1.8m HDMI Cable: Shielded, Detachable, 1.8m (with two cores)			

2.3. Block diagram of connection between the EUT and simulators

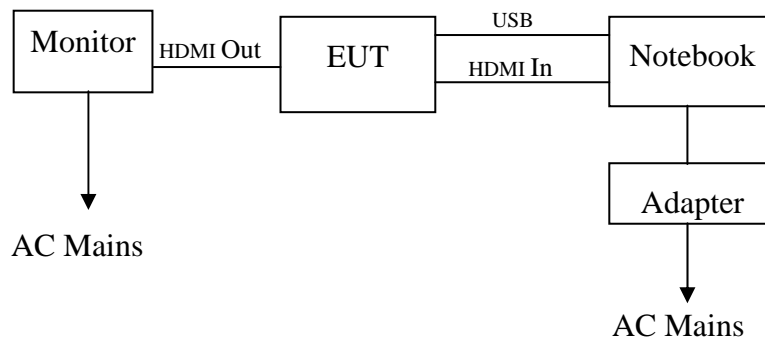

(EUT: Katana HD 7.1 Base Station Receiver)

2.4. Test information

A Special Test Software was used to control EUT work in Continuous TX mode (GFSK modulation), and select test channel.

Tested mode, channel, and data rate information			
Mode	data rate (Mbps)	Channel	Frequency (MHz)
Tx Mode GFSK modulation	3	Low :CH 1	2406
	3	Middle: CH 10	2442
	3	High: CH 18	2474

All Channel List:

Channel 1	2406 MHz
Channel 2	2410 MHz
Channel 3	2414 MHz
Channel 4	2418 MHz
Channel 5	2422 MHz
Channel 6	2426 MHz
Channel 7	2430 MHz
Channel 8	2434 MHz
Channel 9	2438 MHz
Channel 10	2442 MHz
Channel 11	2446 MHz
Channel 12	2450 MHz
Channel 13	2454 MHz
Channel 14	2458 MHz
Channel 15	2462 MHz
Channel 16	2466 MHz
Channel 17	2470 MHz
Channel 18	2474 MHz

2.5. Test Facility

Site Description

Name of Firm : Audix Technology (Shenzhen) Co., Ltd.
 No. 6, Ke Feng Rd., 52 Block, Shenzhen
 Science & Industrial Park, Nantou, Shenzhen,
 Guangdong, China

3m Anechoic Chamber : Certificated by FCC, USA
 Registration Number: 90454
 Valid Date: Dec.30,2017

3m & 10m Anechoic Chamber : Certificated by FCC, USA
 Registration Number: 794232
 Valid Date: Jul.12, 2016

EMC Lab. : Certificated by Industry Canada
 Registration Number: IC 5183A-1
 Valid Date: May.14, 2017

: Certificated by DAkkS, Germany
 Registration No: D-PL-12151-01-00
 Valid Date: Dec.15, 2016

: Accredited by NVLAP, USA
 NVLAP Code: 200372-0
 Valid Date: Mar.31, 2016

2.6. Measurement Uncertainty (95% confidence levels, k=2)

Test Item	Uncertainty
Uncertainty for Radiation Emission test in 3m chamber	2.6 dB(30~200MHz, Polarization: H)
	2.6 dB(30~200MHz, Polarization: V)
	3.0 dB(200M~1GHz, Polarization: H)
	2.8 dB(200M~1GHz, Polarization: V)
Uncertainty for Radiation Emission test in 3m chamber (1GHz-18GHz)	6.3 dB (1~6GHz, Distance: 3m)
	5.7 dB (6~18GHz, Distance: 3m)
Uncertainty for Radiated Spurious Emission test in RF chamber	3.6 dB
Uncertainty for Conduction Spurious emission test	2.0 dB
Uncertainty for Output power test	0.8 dB
Uncertainty for Bandwidth test	83 kHz
Uncertainty for DC power test	0.1 %
Uncertainty for test site temperature and humidity	0.6
	3%

3. POWER LINE CONDUCTED EMISSION TEST

3.1. Test Equipments

Item	Equipment	Manufacturer	Model No.	Serial No.	Last Cal.	Cal. Interval
1.	1# Shielding Room	AUDIX	N/A	N/A	Apr.17,15	1 Year
2.	Test Receiver	Rohde & Schwarz	ESCI	100842	Apr.28,15	1 Year
3.	L.I.S.N.#1	Rohde & Schwarz	ESH2-Z5	100429	Oct.18,15	1 Year
4.	L.I.S.N.#2	Kyoritsu	K NW-403D	8-1750-2	Apr.28,15	1 Year
5.	Terminator	Hubersuhner	50Ω	No.1	Apr.28,15	1 Year
6.	Terminator	Hubersuhner	50Ω	No.2	Apr.28,15	1 Year
7.	RF Cable	MIYAZAKI	3D-2W	No.1	Apr.28,15	1 Year
8.	Coaxial Switch	Anritsu	MP59B	6200766906	Apr.28,15	1 Year
9.	Test Software	AUDIX	e3	6.100913a	N/A	N/A

3.2. Block Diagram of Test Setup

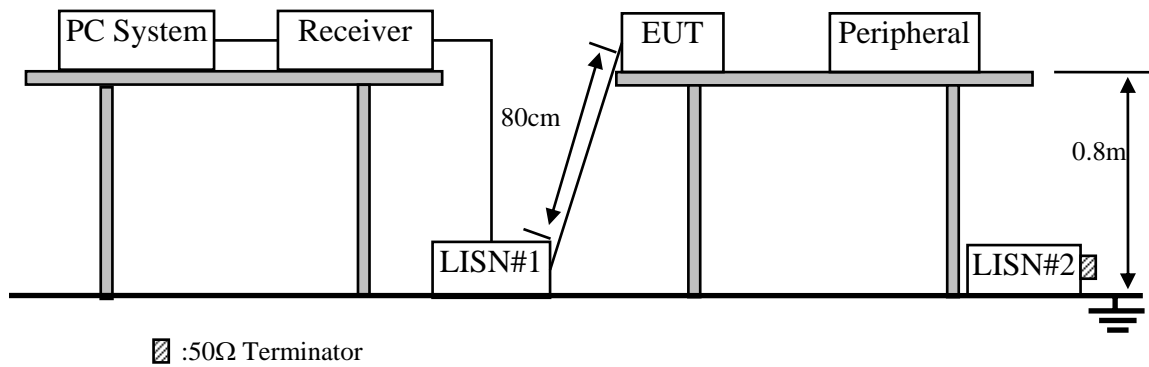

3.3. Power Line Conducted Emission Test Limits

Frequency	Maximum RF Line Voltage	
	Quasi-Peak Level dB(μV)	Average Level dB(μV)
150kHz ~ 500kHz	66 ~ 56*	56 ~ 46*
500kHz ~ 5MHz	56	46
5MHz ~ 30MHz	60	50

Notes: 1. * Decreasing linearly with logarithm of frequency.

2. The lower limit shall apply at the transition frequencies.

3.4. Configuration of EUT on Test

The following equipment are installed on Power Line Conducted Emission Test to meet the commission requirement and operating regulations in a manner which tends to maximize its emission characteristics in a normal application.

3.4.1. Katana HD 7.1 Base Station Receiver (EUT)

Model Number : P25H890977R
Serial Number : N/A

3.4.2. Support Equipment: As Tested Supporting System Details, in Section 2.2.

3.5. Operating Condition of EUT

- 3.5.1. Setup the EUT and simulator as shown as Section 3.2.
- 3.5.2. Turn on the power of all equipments.
- 3.5.3. PC run test software to control EUT work in Tx mode.

3.6. Test Procedure

The EUT was placed on a non-metallic table, 80cm above the ground plane. The EUT Power Via PC connected to the power mains through a line impedance stabilization network (L.I.S.N. #1). This provides a 50 ohm coupling impedance for the EUT (Please refer the block diagram of the test setup and photographs). The AC line are checked to find out the maximum conducted emission. In order to find the maximum emission levels, the relative positions of equipment and all of the interface cables shall be changed according to ANSI C63.10: 2013 on Conducted Emission Test.

The bandwidth of test receiver (R & S ESCI) is set at 9kHz.

The frequency range from 150kHz to 30MHz is checked.

3.7. Power Line Conducted Emission Test Results

PASS. (All emissions not reported below are too low against the prescribed limits.)

Data: 2 File: E:\1#CE\2015 Report Data\MMad Catz\ACS15QH066R2.EM6 (4) Date: 2016-03-23

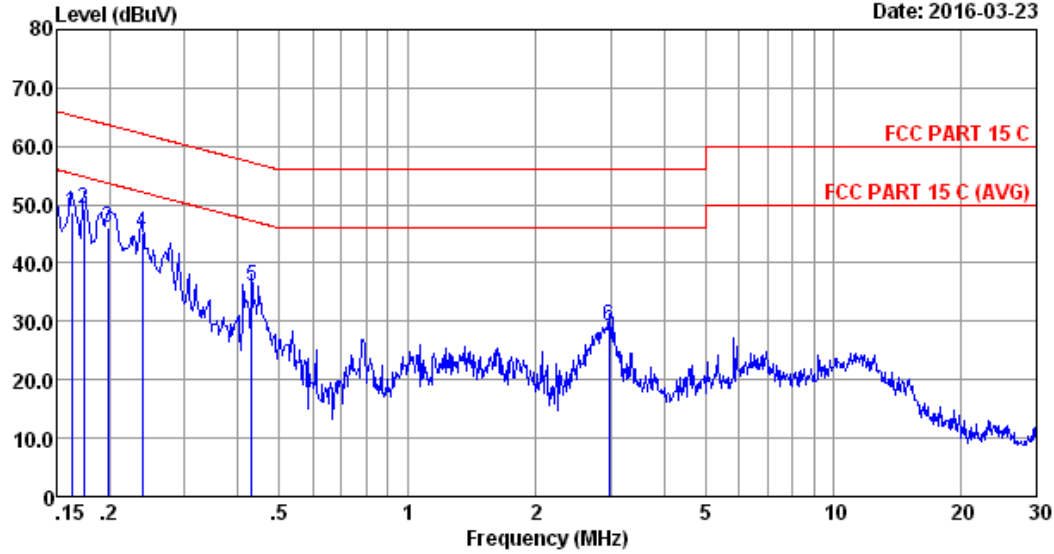

Site no :1# Conduction Data No :2
 Dis./Lisn :2015 ESH2-Z5 LINE
 Limit :FCC PART 15 C
 Env./Ins. :21.2*C/51% Engineer :Leo-Li
 EUT :Katana HD 7.1 Base Station Receiver
 Power Rating :DC 5V From PC Input AC 120V/60Hz
 Test Mode :Tx Mode
 M/N:90977R

No	Freq (MHz)	LISN Factor (dB)	Cable Loss (dB)	Reading (dBuV)	Emission Level (dBuV)	Limits (dBuV)	Margin (dB)	Remark
1	0.162	0.12	0.05	48.68	48.85	65.34	16.49	QP
2	0.174	0.12	0.05	49.00	49.17	64.77	15.60	QP
3	0.198	0.12	0.05	45.87	46.04	63.71	17.67	QP
4	0.238	0.12	0.05	44.98	45.15	62.17	17.02	QP
5	0.431	0.57	0.06	35.36	35.99	57.24	21.25	QP
6	2.978	0.21	0.12	29.02	29.35	56.00	26.65	QP

Remarks: 1.Emission Level=LISN Factor+Cable Loss+Reading.
 2.If the average limit is met when using a quasi-peak detector, the EUT shall be deemed to meet both limits and measurement with average detector is unnecessary.

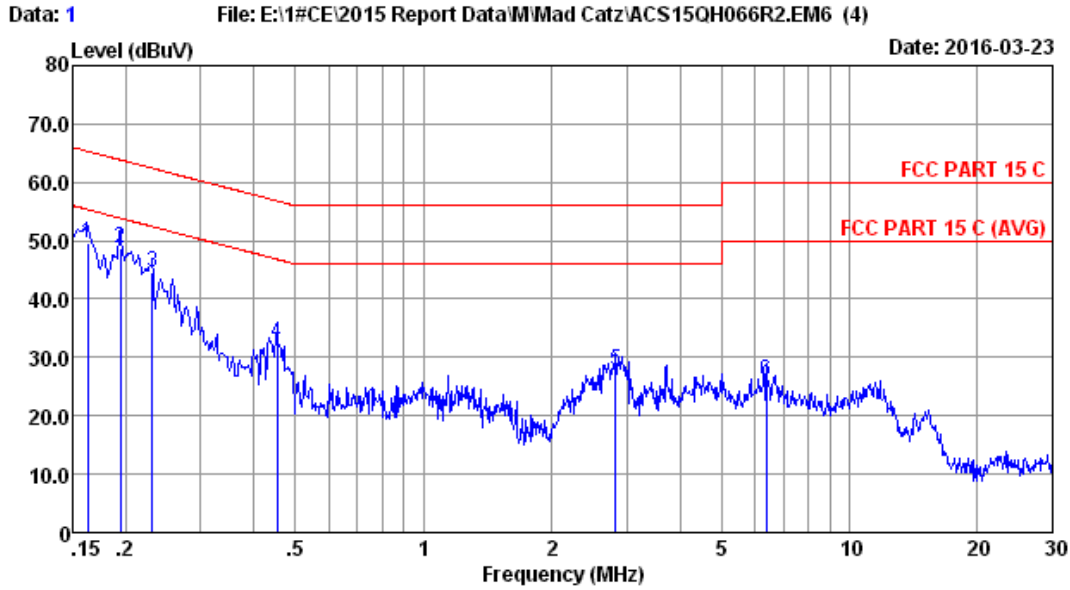

Site no :1# Conduction Data No :1
 Dis./Lisn :2015 ESH2-25 NEUTRAL
 Limit :FCC PART 15 C
 Env./Ins. :21.2*C/51% Engineer :Leo-Li
 EUT :Katana HD 7.1 Base Station Receiver
 Power Rating :DC 5V From PC Input AC 120V/60Hz
 Test Mode :Tx Mode
 M/N:90977R

No	Freq (MHz)	LISN Factor (dB)	Cable Loss (dB)	Reading (dBuV)	Emission Level (dBuV)	Limits (dBuV)	Margin (dB)	Remark
1	0.162	0.12	0.05	49.51	49.68	65.34	15.66	QP
2	0.194	0.12	0.05	48.66	48.83	63.84	15.01	QP
3	0.230	0.13	0.05	44.45	44.63	62.44	17.81	QP
4	0.454	0.14	0.06	32.16	32.36	56.80	24.44	QP
5	2.824	0.22	0.12	27.31	27.65	56.00	28.35	QP
6	6.386	0.33	0.15	25.39	25.87	60.00	34.13	QP

Remarks: 1.Emission Level=LISN Factor+Cable Loss+Reading.
 2.If the average limit is met when using a quasi-peak detector, the EUT shall be deemed to meet both limits and measurement with average detector is unnecessary.

4. RADIATED EMISSION MEASUREMENT

4.1. Test Equipment

Frequency range: 30~1000MHz

Item	Equipment	Manufacturer	Model No.	Serial No.	Last Cal.	Cal. Interval
1.	3#Chamber	AUDIX	N/A	N/A	Mar.28,15	1 Year
2.	EMI Spectrum	Agilent	E4407B	MY41440292	Apr.28,15	1 Year
3.	Test Receiver	Rohde & Schwarz	ESVS10	834468/011	Apr.28,15	1 Year
4.	Amplifier	HP	8447D	2648A04738	Apr.28,15	1 Year
5.	Trilog-Broadband Antenna	SCHWARZBECK	VULB 9168	9168-493	May.06,15	1 Year
6.	RF Cable	MIYAZAKI	CFD400-N W(3.5M)	No.3	Apr.28,15	1 Year
7.	RF Cable	MIYAZAKI	CFD400-L W(22M)	No.7	Apr.28,15	1 Year
8.	Coaxial Switch	Anritsu	MP59B	6201397222	Apr.28,15	1 Year
9.	Test Software	AUDIX	e3	6.2009-5-21a(n)	N/A	N/A

Frequency range: above 1000MHz

Item	Equipment	Manufacturer	Model No.	Serial No.	Last Cal.	Cal. Interval
1.	Spectrum Analyzer	Agilent	E4446A	US44300459	Apr.28,15	1 Year
2.	Horn Antenna	ETC	MCTD 1209	DRH15F03007	Feb.03,15	1 Year
3.	Amplifier	Agilent	8449B	3008A02495	Apr.28,15	1 Year
4.	RF Cable	Hubersuhner	SUCOFLEX106	77977/6	Apr.28,15	1 Year
5.	Horn Antenna	ETS	3116	00060088	Nov.18.15	1 Year
6.	Test Software	AUDIX	e3	6.2009-5-21a(n)	N/A	N/A

4.2. Block Diagram of Test Setup
For frequency range 30MHz-1000MHz

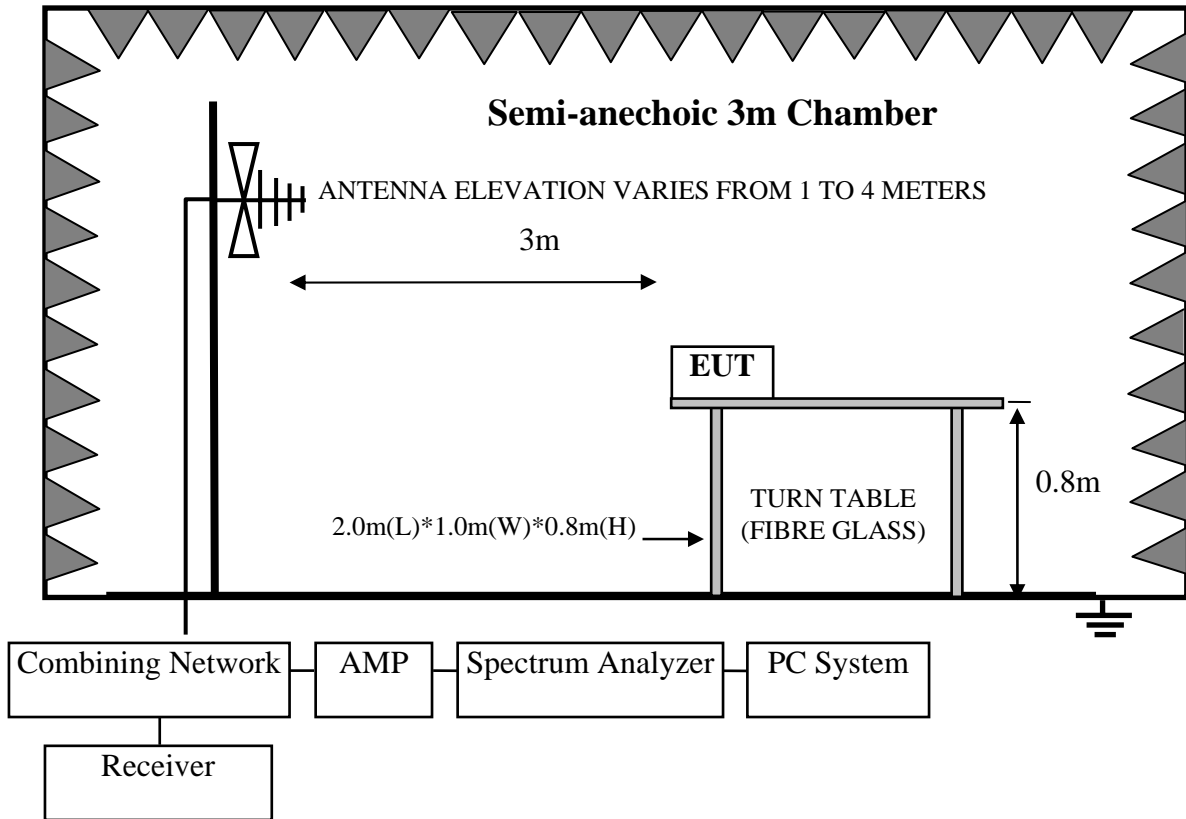

For frequency range 1GHz-25GHz

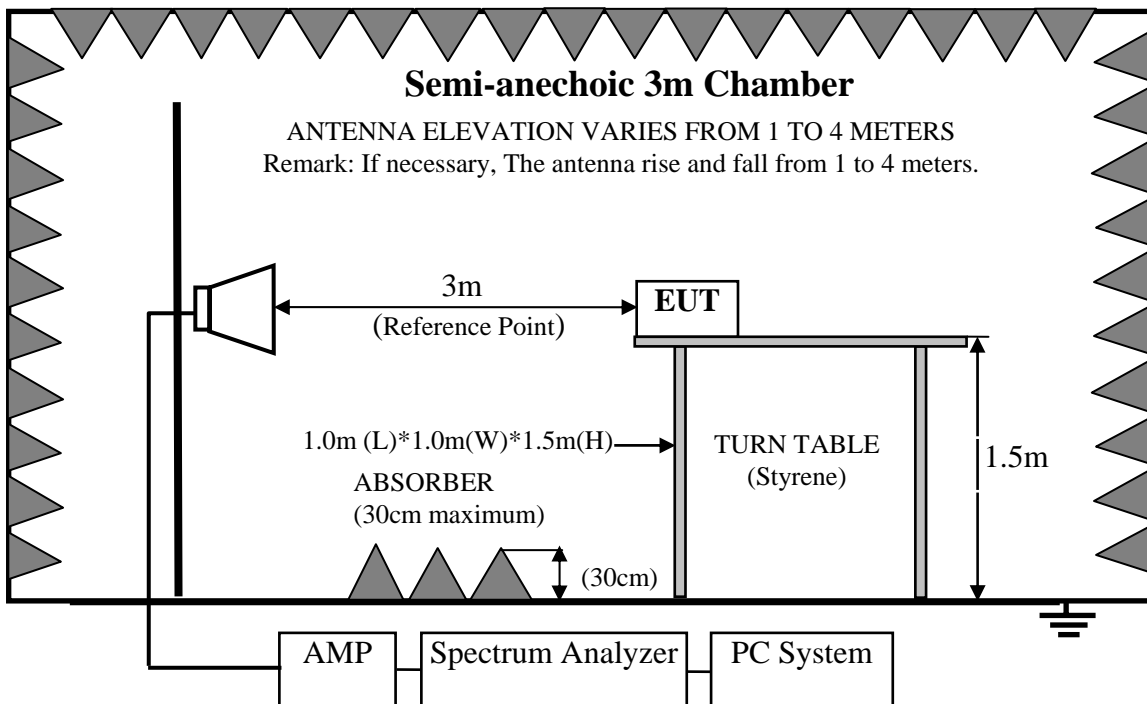

4.3. Radiated Emission Limit Standard:

FREQUENCY MHz	DISTANCE Meters	FIELD STRENGTHS LIMIT	
		μV/m	dB(μV)/m
30 ~ 88	3	100	40.0
88 ~ 216	3	150	43.5
216 ~ 960	3	200	46.0
960 ~ 1000	3	500	54.0
Above 1000MHz	3	74.0 dB(μV)/m (Peak) 54.0 dB(μV)/m (Average)	

- Remark :
- (1) Emission level dBμV = 20 log Emission level μV/m
 - (2) The smaller limit shall apply at the cross point between two frequency bands.
 - (3) Distance is the distance in meters between the measuring instrument, antenna and the closest point of any part of the device or system.
 - (4) The emission limits shown in the above table are based on measurements employing a CISPR quasi-peak detector except for the frequency bands 9-90 kHz, 110-490 kHz and above 1000 MHz. Radiated emission limits in these three bands are based on measurements employing an average detector.

4.4. EUT Configuration on Test

The following equipment are installed on Radiated Emission Test to meet the commission requirements and operating regulations in a manner which tends to maximize its emission characteristics in normal application.

4.4.1. Katana HD 7.1 Base Station Receiver (EUT)

Model Number : 90977R
 Serial Number : N/A

4.5. Operating Condition of EUT

- 4.5.1. Setup the EUT and simulator as shown as Section 4.2.
- 4.5.2. Turn on the power of all equipments.
- 4.5.3. Let EUT work in Tx mode.

4.6. Test Procedure

EUT and its simulators are placed on a turn table, which is 0.8 meter high above ground for frequency 30MHz~1000MHz, 1.5 meter high above ground for frequency above 1GHz and put the absorbing with 2.4m(L)*2.4m(W)*0.3m(H) on the ground . The turn table can rotate 360 degrees to determine the position of the maximum emission level. Power on the EUT and let it working in test mode, then test it.EUT is set 3 meters away from the receiving antenna, which is mounted on a antenna tower. The antenna can be moved up and down between 1 meter and 4 meters to find out the maximum emission level. Broadband antenna (calibrated bilog antenna) is used as receiving antenna for frequency 30MHz~1000MHz, and the Horn antenna is used as receiving antenna for frequency above 1GHz. Both horizontal and vertical polarization of the antenna is set on Test. In order to find the maximum emission levels, all of the interface cables must be manipulated according to ANSI C63.10-2013 on radiated emission Test.

This test was performed with EUT in X, Y, Z position, and the worse case was found when EUT in X position as the test photo indicated.

The bandwidth of the EMI test receiver (R&S ESVS10) is set at 120kHz for frequency range from 30MHz to 1000 MHz.

The bandwidth of the Spectrum's RBW is set at 1MHz and VBW is set at 3MHz for peak emissions measurement and RBW is set at 1MHz, VBW is set at 10MHz for average measurement

The frequency range from 30MHz to 10th harmonic (25GHz) are checked. and no any emissions were found from 18GHz to 25 GHz, So the radiated emissions from 18GHz to 25GHz were not record.

4.7. Radiated Emission Test Results

PASS.

All the emissions from 30MHz to 25GHz were comply with the 15.209 Limit.

Note: For emissions above 1GHz, if peak level comply with average limit, then the average level is deemed to comply with average limit.

Duty cycle

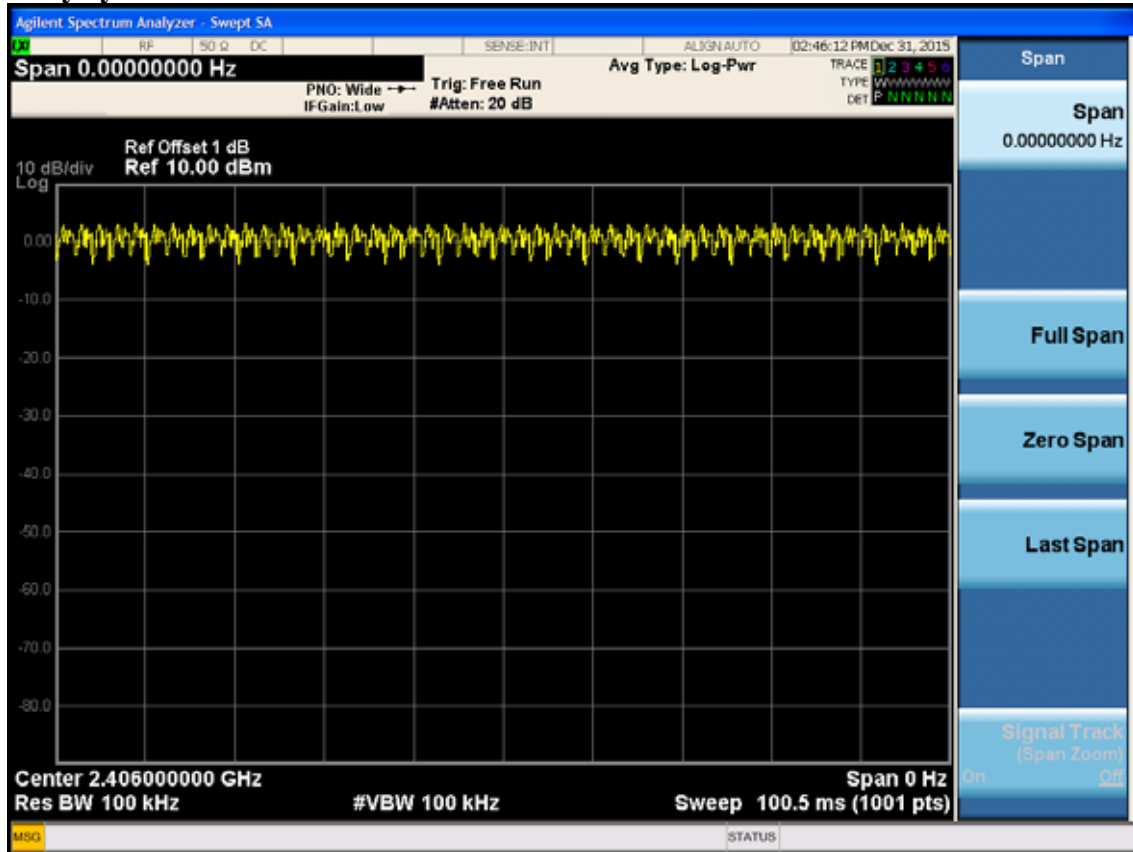

Note: The Duty Cycle is close to 100%.

Frequency: 30MHz~1GHz

Data: 12

File: E:\2015 Report Data\M\mad catz\ACS15QH066R2.EM6 (12)

Date: 2016-03-22

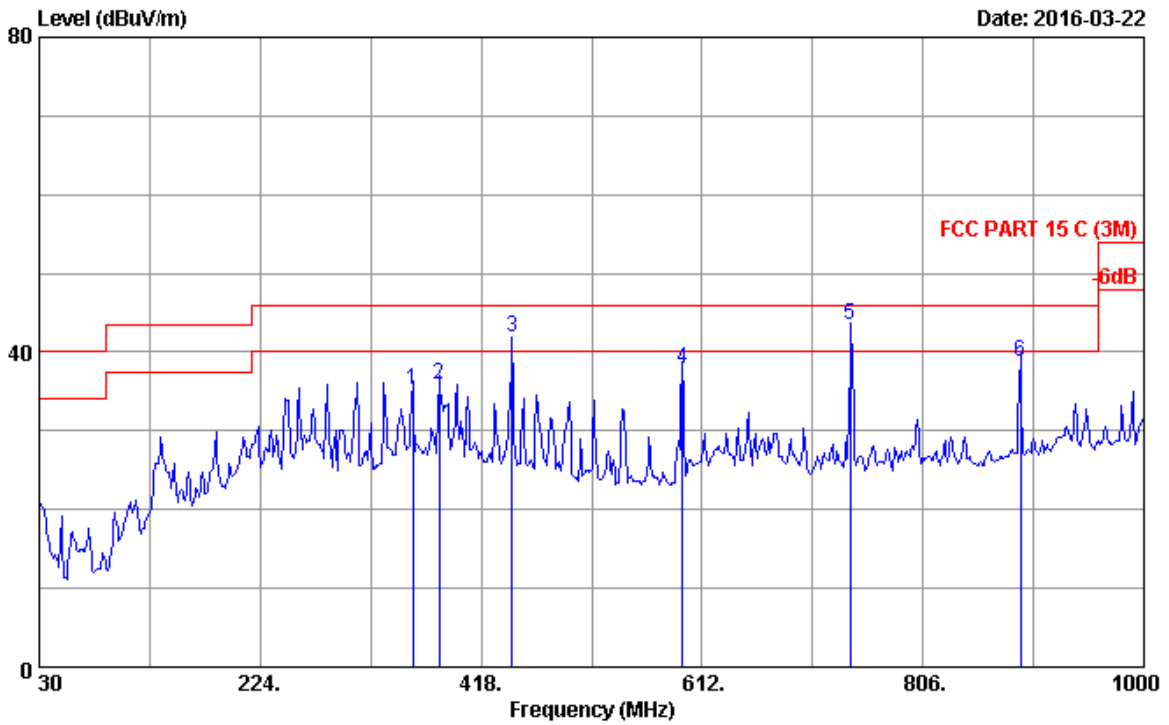

Site no. : 3m Chamber Data no. : 12
 Dis. / Ant. : 3m 2015 CBL6112D 35375 Ant. pol. : HORIZONTAL
 Limit : FCC PART 15 C (3M)
 Env. / Ins. : 25.1°C/48% Engineer : Leo-Li
 EUT : Katana HD 7.1 Base Station Receiver
 Power rating : DC 5V From PC Input AC 120V/60Hz
 Test Mode : Tx Mode
 M/N:90977R

No.	Freq. (MHz)	Ant. Factor (dB/m)	Cable Loss (dB)	Reading (dBuV)	Emission Level (dBuV/m)	Limits (dBuV/m)	Margin (dB)	Remark
1	357.860	15.77	2.07	17.44	35.28	46.00	10.72	QP
2	381.140	16.40	2.14	17.41	35.95	46.00	10.05	QP
3	445.160	17.58	2.36	21.93	41.87	46.00	4.13	QP
4	594.540	19.25	2.75	15.83	37.83	46.00	8.17	QP
5	741.748	20.52	3.12	19.80	43.44	46.00	2.56	QP
6	891.360	21.92	3.47	13.48	38.87	46.00	7.13	QP

Remarks: 1. Emission Level= Antenna Factor + Cable Loss + Reading.
 2. The emission levels that are 20dB below the official limit are not reported.

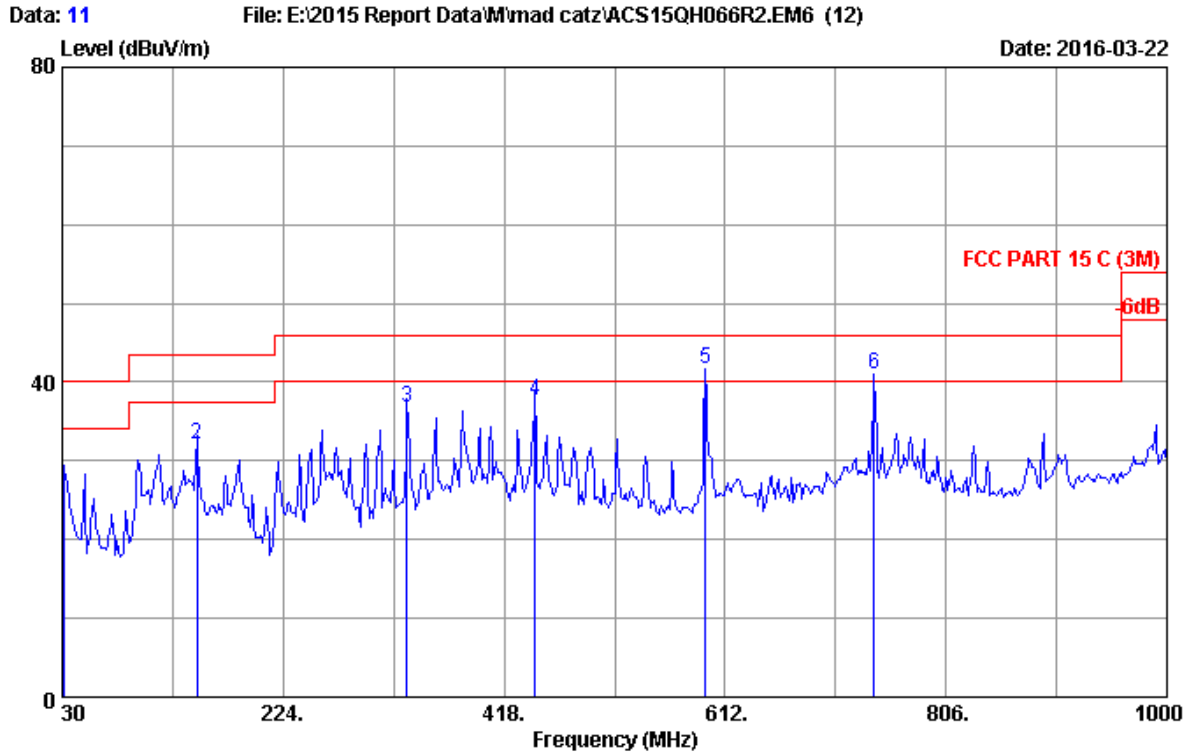

Site no. : 3m Chamber Data no. : 11
 Dis. / Ant. : 3m 2015 CBL6112D 35375 Ant. pol. : VERTICAL
 Limit : FCC PART 15 C (3M)
 Env. / Ins. : 25.1°C/48% Engineer : Leo-Li
 EUT : Katana HD 7.1 Base Station Receiver
 Power rating : DC 5V From PC Input AC 120V/60Hz
 Test Mode : Tx Mode
 M/N:90977R

No.	Freq. (MHz)	Ant. Factor (dB/m)	Cable Loss (dB)	Reading (dBuV)	Emission Level (dBuV/m)	Limits (dBuV/m)	Margin (dB)	Remark
1	31.940	19.06	0.61	7.09	26.76	40.00	13.24	QP
2	148.340	11.71	1.29	19.11	32.11	43.50	11.39	QP
3	332.640	15.09	2.01	19.68	36.78	46.00	9.22	QP
4	445.160	17.58	2.36	17.78	37.72	46.00	8.28	QP
5	594.540	19.25	2.75	19.60	41.60	46.00	4.40	QP
6	742.950	20.53	3.12	17.44	41.09	46.00	4.91	QP

Remarks: 1. Emission Level= Antenna Factor + Cable Loss + Reading.
 2. The emission levels that are 20dB below the official limit are not reported.

Frequency: 1GHz~18GHz

Data: 1

File: F:\2015 Report\MMadcatz\ACS15QH066R2.EM6 (40)

Date: 2015-12-28

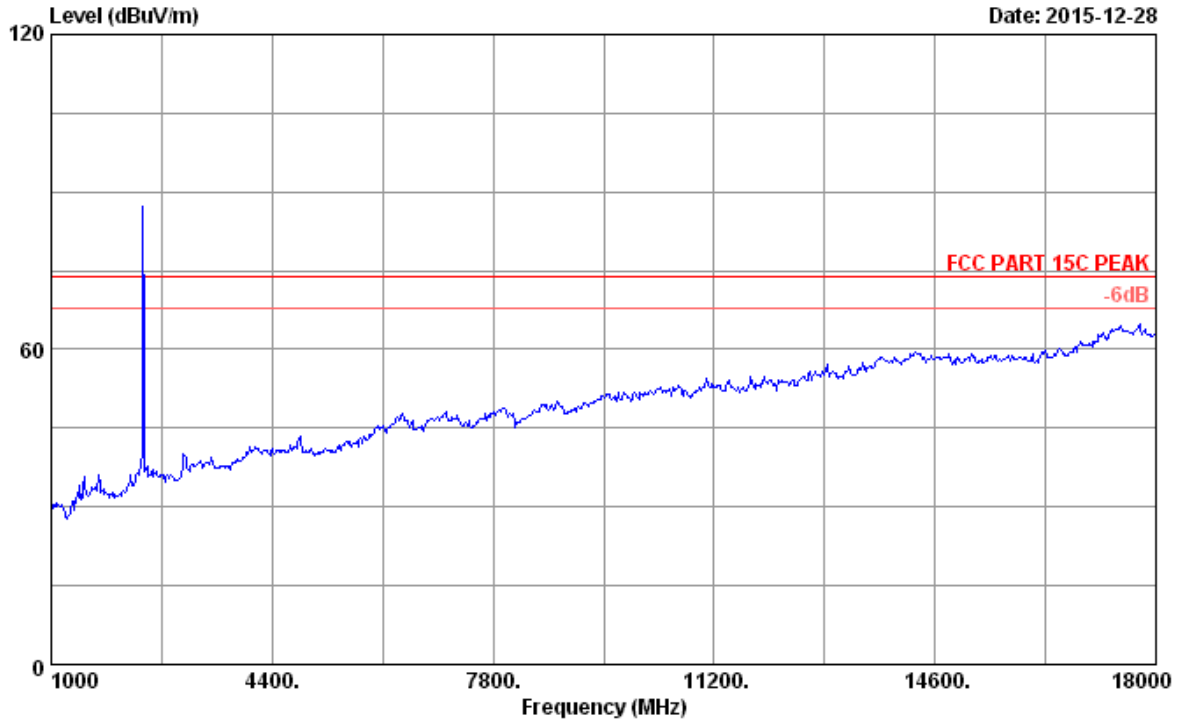

Site no. : 3m Chamber Data no. : 1
Dis. / Ant. : 3m 2015 MCTD1209 3007 Ant. pol. : VERTICAL
Limit : FCC PART 15C PEAK
Env. / Ins. : 23.4*C/53.2%
Engineer : Leo-Li
EUT : Katana HD 7.1 Base Station Receiver
Power rating : DC 5V From PC Input AC 120V/60Hz
Test Mode : 2406MHz Tx
90977R

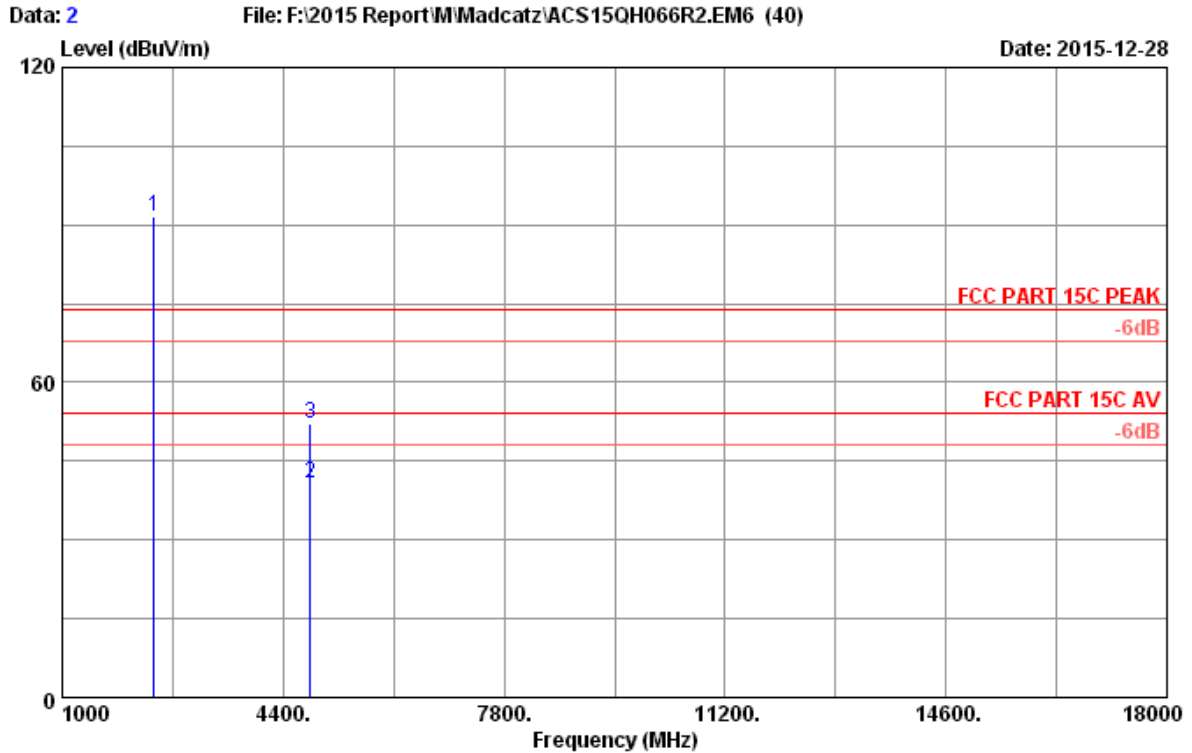

Site no. : 3m Chamber Data no. : 2
 Dis. / Ant. : 3m 2015 MCTD1209 3007 Ant. pol. : VERTICAL
 Limit : FCC PART 15C PEAK
 Env. / Ins. : 23.4°C/53.2%
 Engineer : Leo-Li
 EUT : Katana HD 7.1 Base Station Receiver
 Power rating : DC 5V From PC Input AC 120V/60Hz
 Test Mode : 2406MHz Tx
 90977R

No.	Freq. (MHz)	Ant. Factor (dB/m)	Cable Loss (dB)	AMP factor (dB)	Reading (dBuV)	Emission Level (dBuV/m)	Limits (dBuV/m)	Margin (dB)	Remark
1	2406.000	27.81	7.32	36.62	93.03	91.54	74.00	-17.54	Peak
2	4812.000	32.29	9.46	35.54	34.70	40.91	54.00	13.09	Average
3	4812.000	32.29	9.46	35.54	46.08	52.29	74.00	21.71	Peak

Remarks: 1. Emission Level= Antenna Factor + Cable Loss + Reading - Amp Factor
 2. The emission levels that are 20dB below the official limit are not reported.

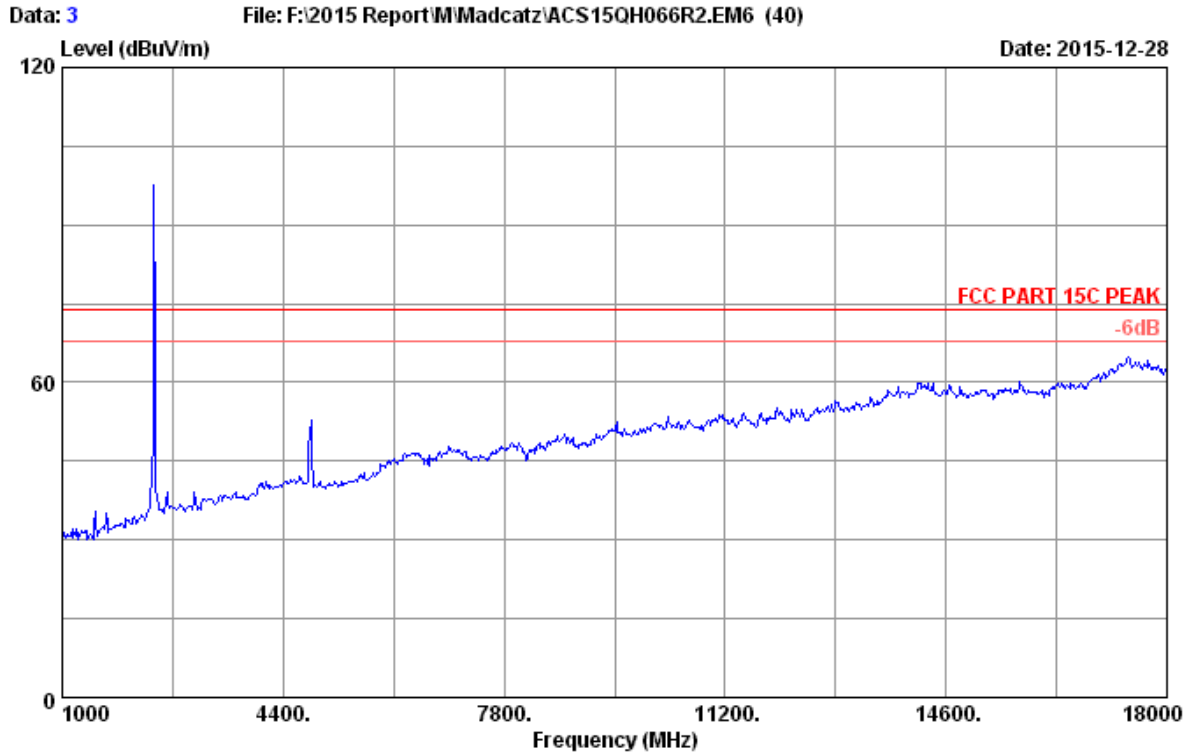

Site no. : 3m Chamber Data no. : 3
Dis. / Ant. : 3m 2015 MCTD1209 3007 Ant. pol. : HORIZONTAL
Limit : FCC PART 15C PEAK
Env. / Ins. : 23.4°C/53.2%
Engineer : Leo-Li
EUT : Katana HD 7.1 Base Station Receiver
Power rating : DC 5V From PC Input AC 120V/60Hz
Test Mode : 2406MHz Tx
90977R

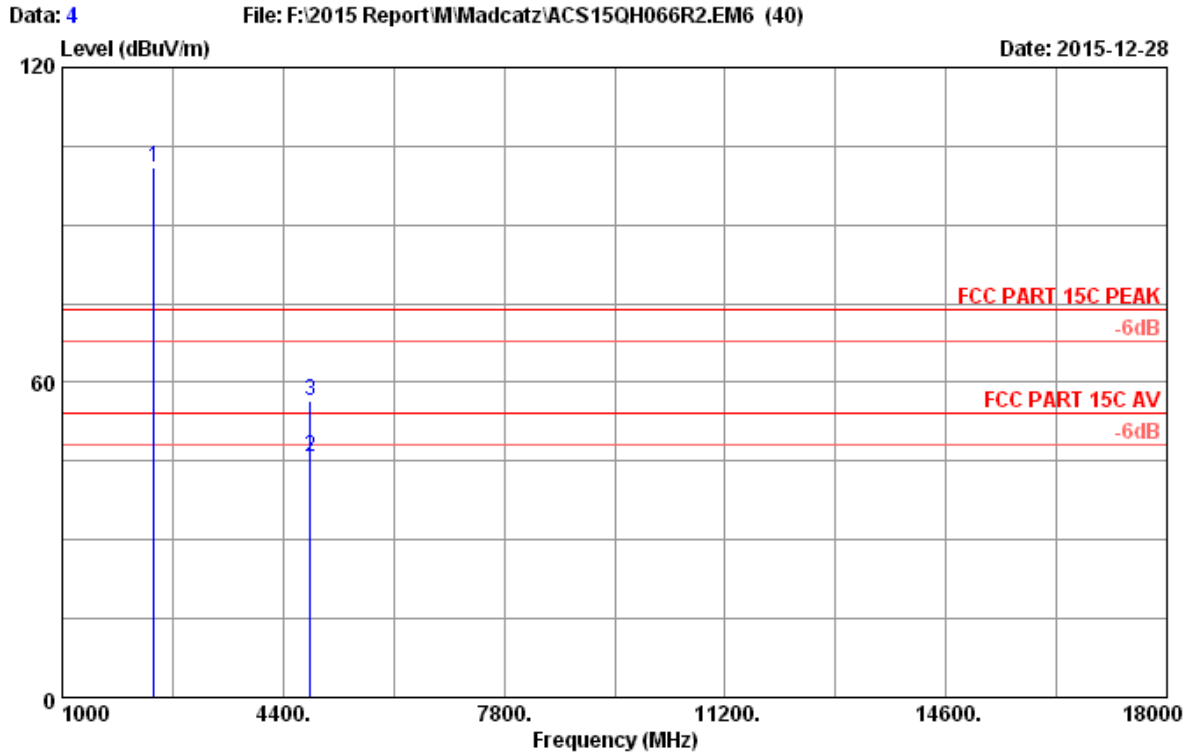

Site no. : 3m Chamber Data no. : 4
 Dis. / Ant. : 3m 2015 MCTD1209 3007 Ant. pol. : HORIZONTAL
 Limit : FCC PART 15C PEAK
 Env. / Ins. : 23.4°C/53.2%
 Engineer : Leo-Li
 EUT : Katana HD 7.1 Base Station Receiver
 Power rating : DC 5V From PC Input AC 120V/60Hz
 Test Mode : 2406MHz Tx
 90977R

No.	Freq. (MHz)	Ant. Factor (dB/m)	Cable Loss (dB)	AMP factor (dB)	Reading (dBUV)	Emission Level (dBUV/m)	Limits (dBUV/m)	Margin (dB)	Remark
1	2406.000	27.81	7.32	36.62	102.54	101.05	74.00	-27.05	Peak
2	4812.000	32.29	9.46	35.54	39.69	45.90	54.00	8.10	Average
3	4812.000	32.29	9.46	35.54	50.34	56.55	74.00	17.45	Peak

Remarks: 1. Emission Level= Antenna Factor + Cable Loss + Reading - Amp Factor
 2. The emission levels that are 20dB below the official limit are not reported.

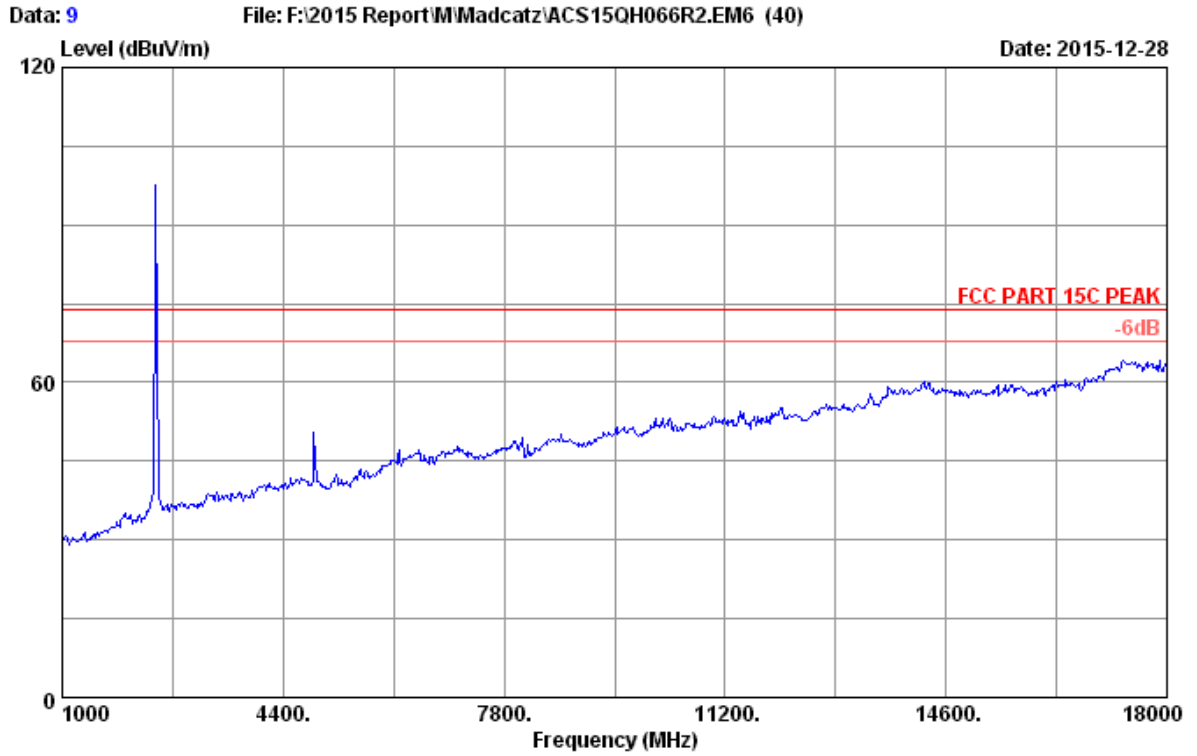

Site no. : 3m Chamber Data no. : 9
Dis. / Ant. : 3m 2015 MCTD1209 3007 Ant. pol. : HORIZONTAL
Limit : FCC PART 15C PEAK
Env. / Ins. : 23.4°C/53.2%
Engineer : Leo-Li
EUT : Katana HD 7.1 Base Station Receiver
Power rating : DC 5V From PC Input AC 120V/60Hz
Test Mode : 2442MHz Tx
90977R

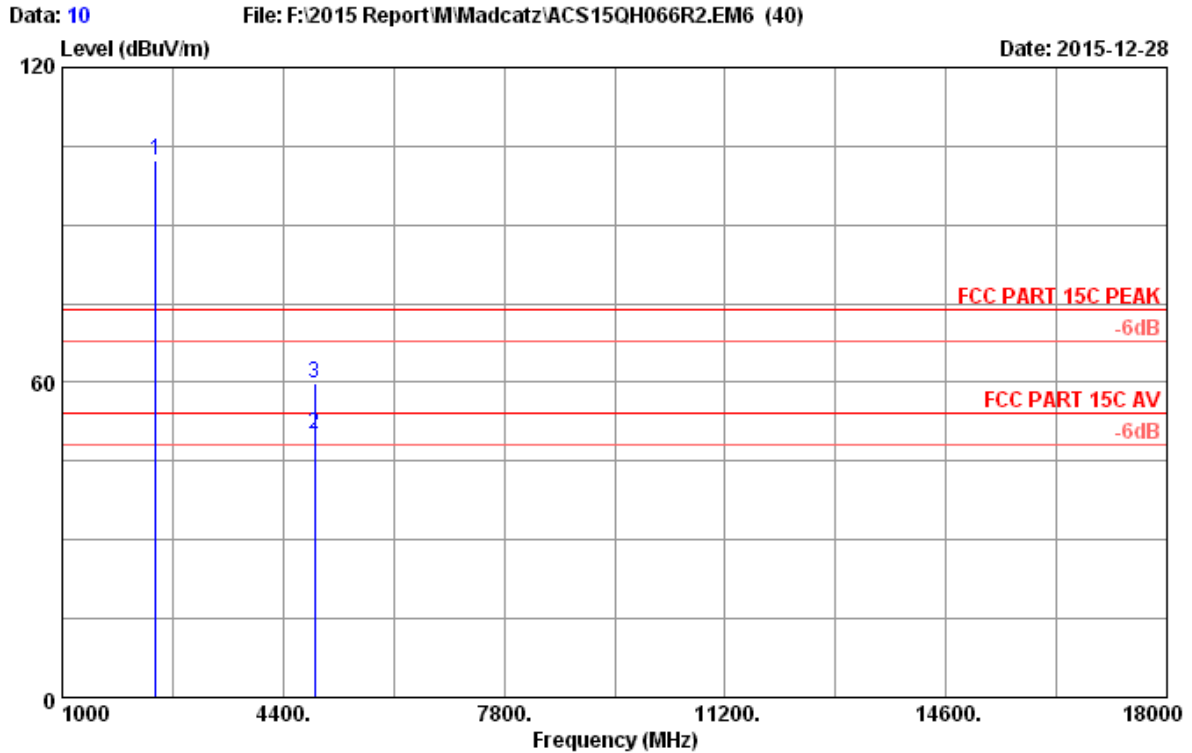

Site no. : 3m Chamber Data no. : 10
 Dis. / Ant. : 3m 2015 MCTD1209 3007 Ant. pol. : HORIZONTAL
 Limit : FCC PART 15C PEAK
 Env. / Ins. : 23.4°C/53.2%
 Engineer : Leo-Li
 EUT : Katana HD 7.1 Base Station Receiver
 Power rating : DC 5V From PC Input AC 120V/60Hz
 Test Mode : 2442MHz Tx
 90977R

No.	Freq. (MHz)	Ant. Factor (dB/m)	Cable Loss (dB)	AMP factor (dB)	Reading (dBUV)	Emission Level (dBUV/m)	Limits (dBUV/m)	Margin (dB)	Remark
1	2442.000	27.88	7.39	36.60	103.61	102.28	74.00	-28.28	Peak
2	4884.000	32.22	9.49	35.51	44.06	50.26	54.00	3.74	Average
3	4884.000	32.22	9.49	35.51	53.55	59.75	74.00	14.25	Peak

Remarks: 1. Emission Level= Antenna Factor + Cable Loss + Reading - Amp Factor
 2. The emission levels that are 20dB below the official limit are not reported.

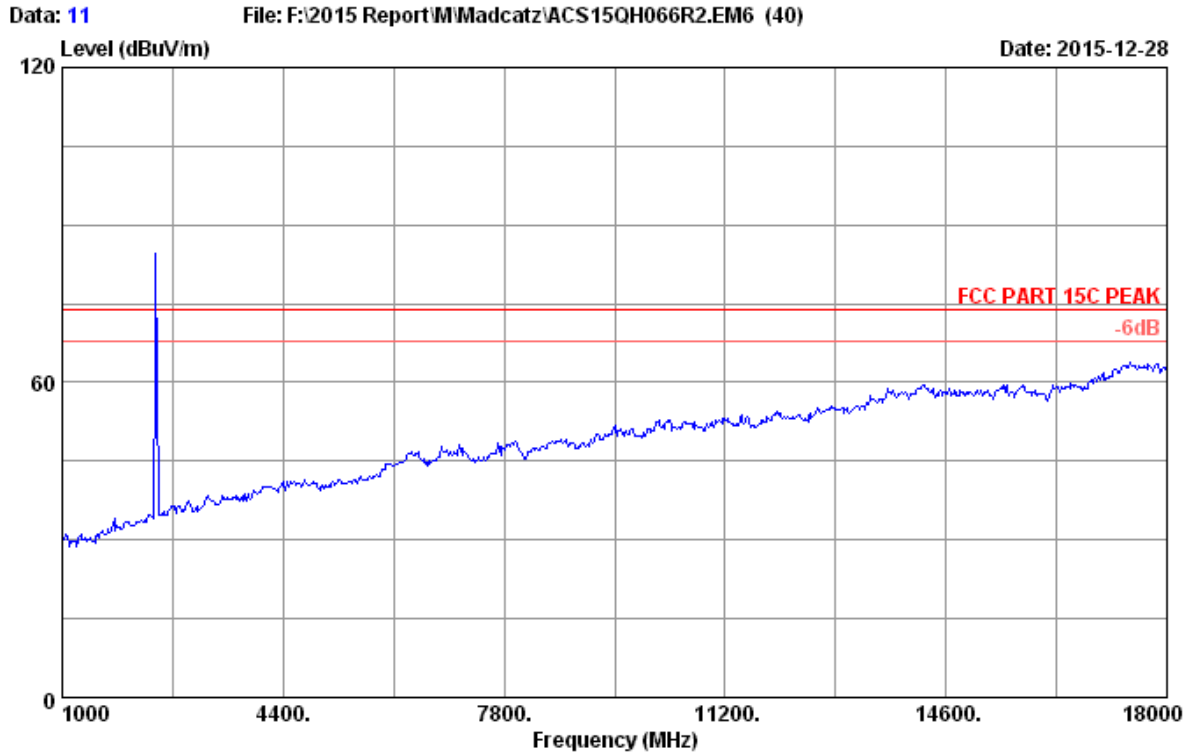

Site no. : 3m Chamber Data no. : 11
Dis. / Ant. : 3m 2015 MCTD1209 3007 Ant. pol. : VERTICAL
Limit : FCC PART 15C PEAK
Env. / Ins. : 23.4°C/53.2%
Engineer : Leo-Li
EUT : Katana HD 7.1 Base Station Receiver
Power rating : DC 5V From PC Input AC 120V/60Hz
Test Mode : 2442MHz Tx
90977R

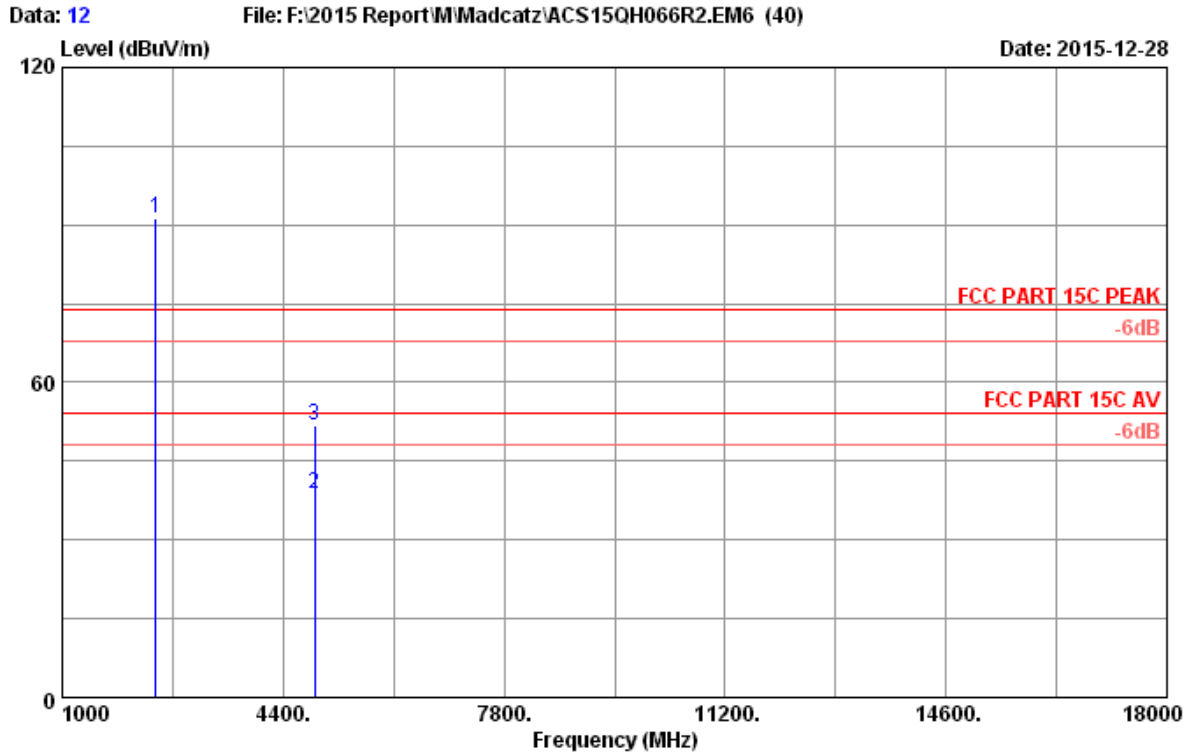

Site no. : 3m Chamber Data no. : 12
 Dis. / Ant. : 3m 2015 MCTD1209 3007 Ant. pol. : VERTICAL
 Limit : FCC PART 15C PEAK
 Env. / Ins. : 23.4°C/53.2%
 Engineer : Leo-Li
 EUT : Katana HD 7.1 Base Station Receiver
 Power rating : DC 5V From PC Input AC 120V/60Hz
 Test Mode : 2442MHz Tx
 90977R

No.	Freq. (MHz)	Ant. Factor (dB/m)	Cable Loss (dB)	AMP factor (dB)	Reading (dBUV)	Emission Level (dBUV/m)	Limits (dBUV/m)	Margin (dB)	Remark
1	2442.000	27.88	7.39	36.60	92.56	91.23	74.00	-17.23	Peak
2	4884.000	32.22	9.49	35.51	32.47	38.67	54.00	15.33	Average
3	4884.000	32.22	9.49	35.51	45.53	51.73	74.00	22.27	Peak

Remarks: 1. Emission Level= Antenna Factor + Cable Loss + Reading - Amp Factor
 2. The emission levels that are 20dB below the official limit are not reported.

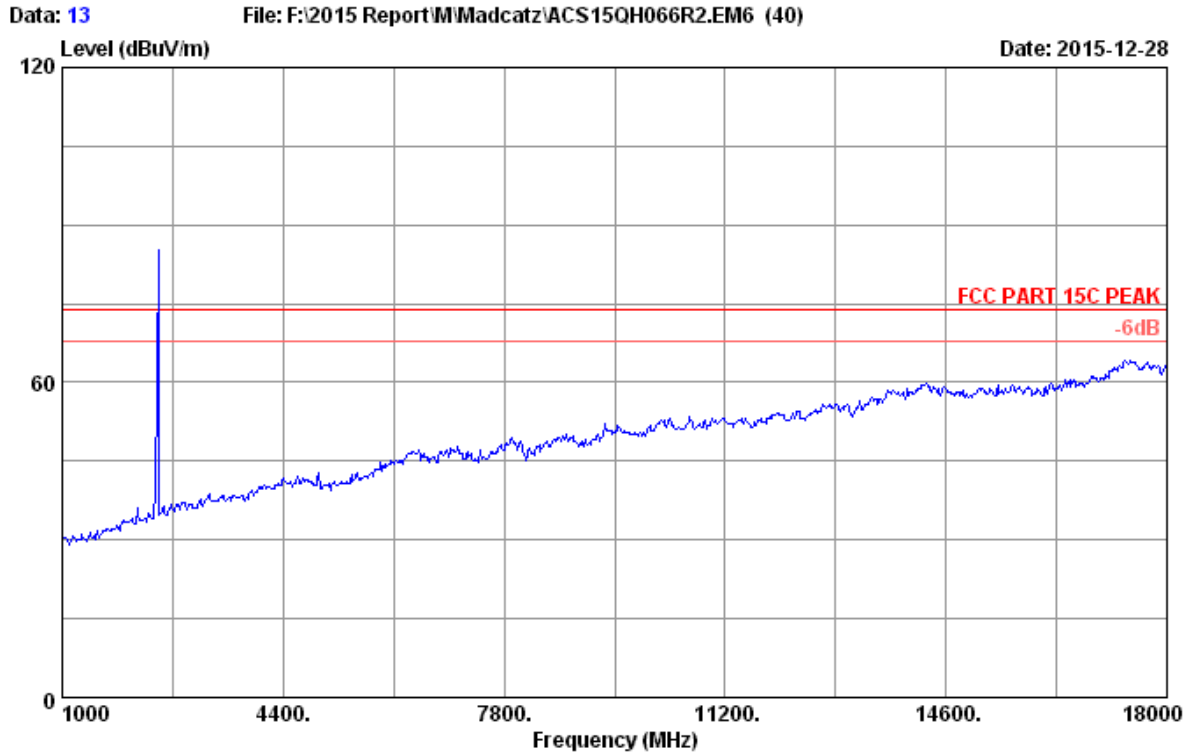

Site no. : 3m Chamber Data no. : 13
Dis. / Ant. : 3m 2015 MCTD1209 3007 Ant. pol. : VERTICAL
Limit : FCC PART 15C PEAK
Env. / Ins. : 23.4°C/53.2%
Engineer : Leo-Li
EUT : Katana HD 7.1 Base Station Receiver
Power rating : DC 5V From PC Input AC 120V/60Hz
Test Mode : 2474MHz Tx
90977R

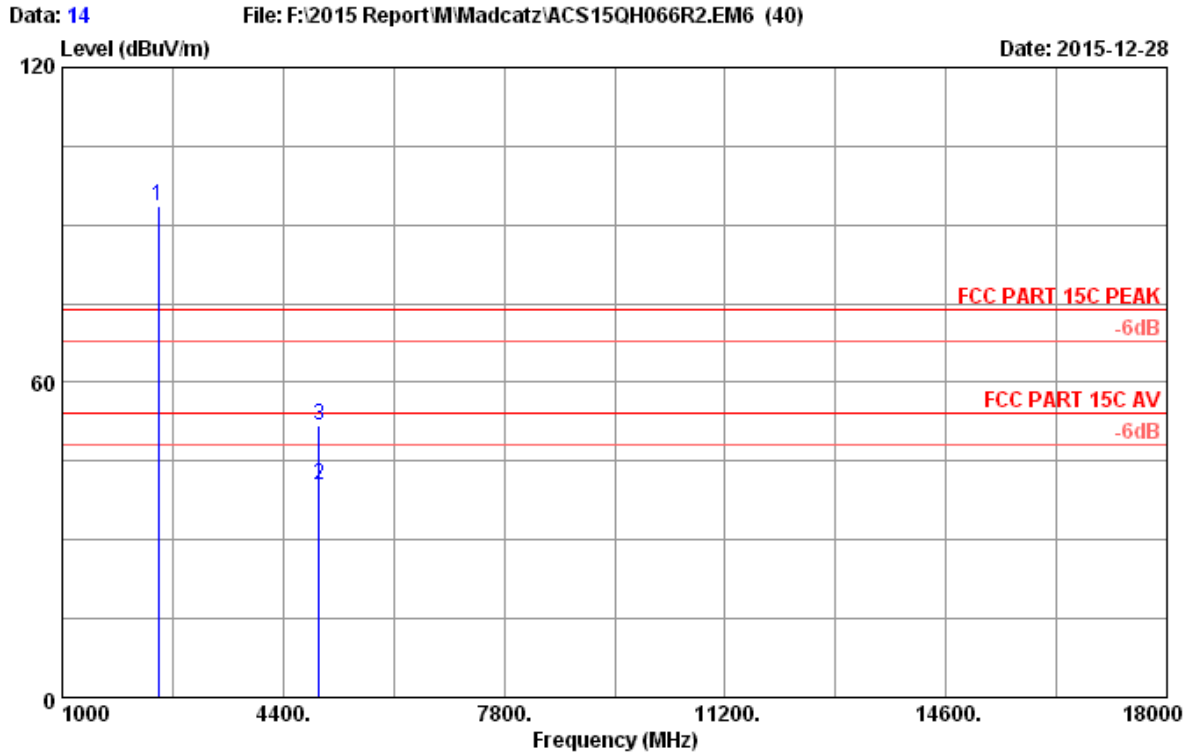

Site no. : 3m Chamber Data no. : 14
 Dis. / Ant. : 3m 2015 MCTD1209 3007 Ant. pol. : VERTICAL
 Limit : FCC PART 15C PEAK
 Env. / Ins. : 23.4°C/53.2%
 Engineer : Leo-Li
 EUT : Katana HD 7.1 Base Station Receiver
 Power rating : DC 5V From PC Input AC 120V/60Hz
 Test Mode : 2474MHz Tx
 90977R

No.	Freq. (MHz)	Ant. Factor (dB/m)	Cable Loss (dB)	AMP factor (dB)	Reading (dBUV)	Emission Level (dBUV/m)	Limits (dBUV/m)	Margin (dB)	Remark
1	2474.000	27.95	7.47	36.59	94.68	93.51	74.00	-19.51	Peak
2	4958.000	32.14	9.52	35.47	34.26	40.45	54.00	13.55	Average
3	4958.000	32.14	9.52	35.47	45.47	51.66	74.00	22.34	Peak

Remarks: 1. Emission Level= Antenna Factor + Cable Loss + Reading - Amp Factor
 2. The emission levels that are 20dB below the official limit are not reported.

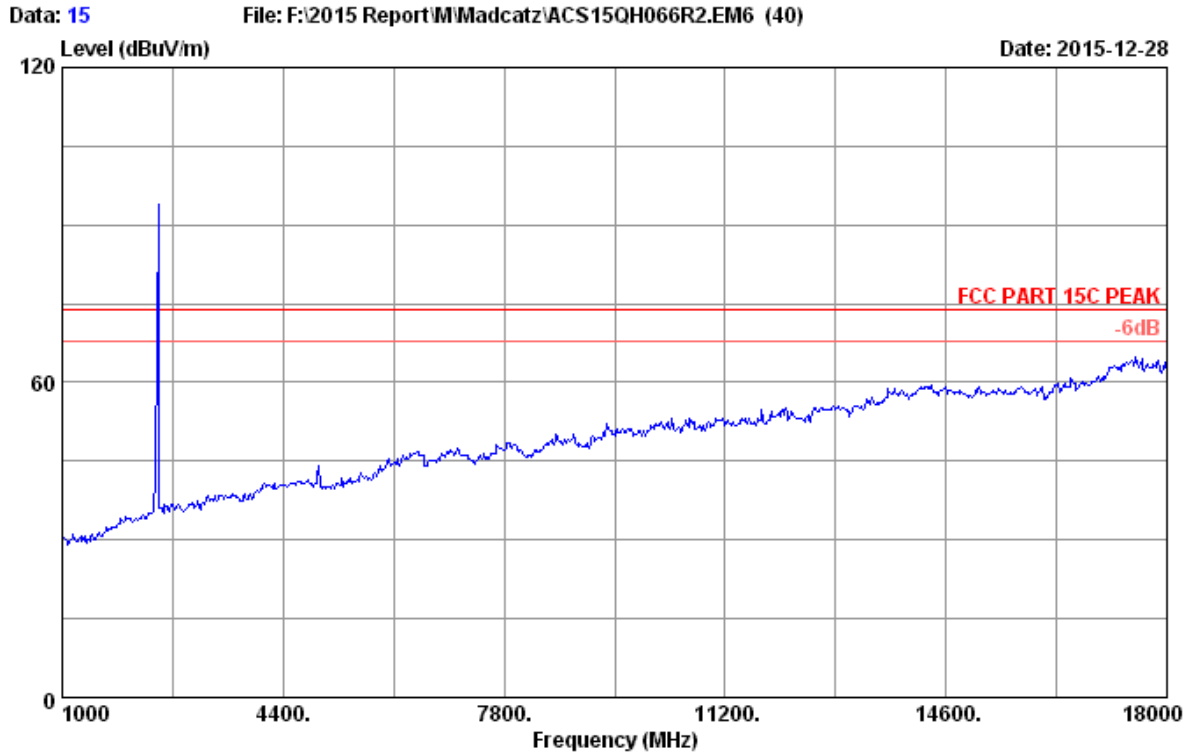

Site no. : 3m Chamber Data no. : 15
Dis. / Ant. : 3m 2015 MCTD1209 3007 Ant. pol. : HORIZONTAL
Limit : FCC PART 15C PEAK
Env. / Ins. : 23.4°C/53.2%
Engineer : Leo-Li
EUT : Katana HD 7.1 Base Station Receiver
Power rating : DC 5V From PC Input AC 120V/60Hz
Test Mode : 2474MHz Tx
90977R

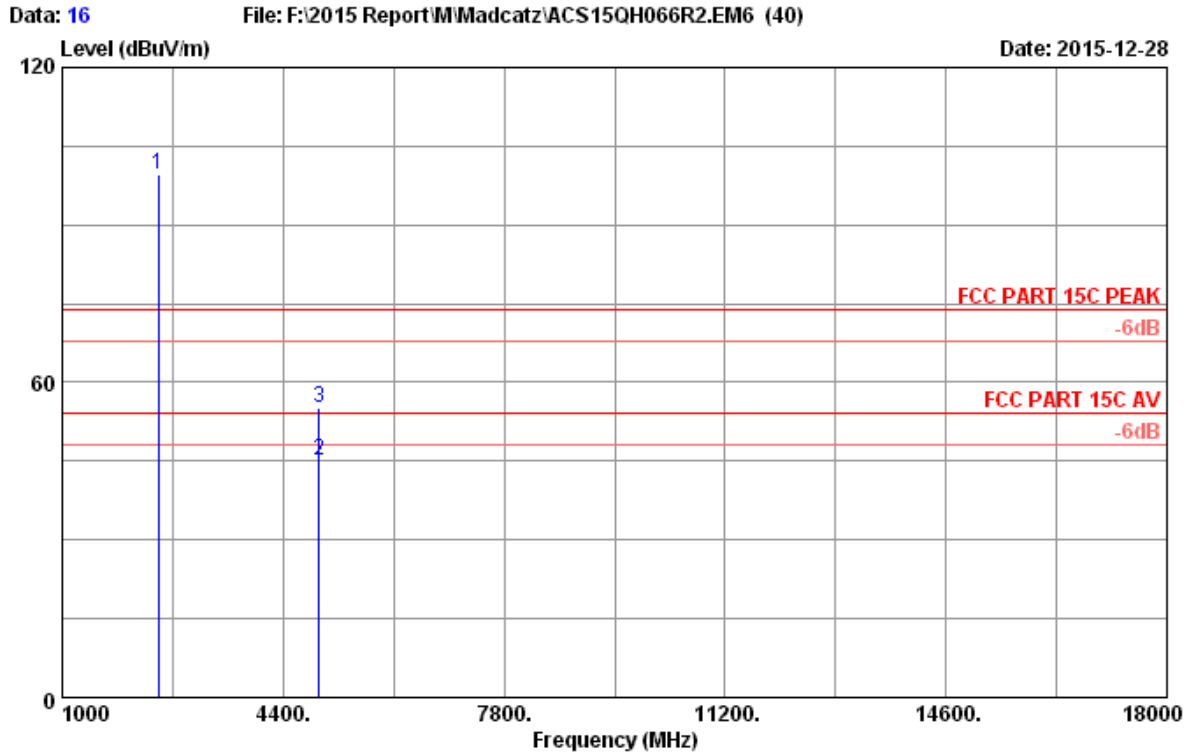

Site no. : 3m Chamber Data no. : 16
 Dis. / Ant. : 3m 2015 MCTD1209 3007 Ant. pol. : HORIZONTAL
 Limit : FCC PART 15C PEAK
 Env. / Ins. : 23.4°C/53.2%
 Engineer : Leo-Li
 EUT : Katana HD 7.1 Base Station Receiver
 Power rating : DC 5V From PC Input AC 120V/60Hz
 Test Mode : 2474MHz Tx
 90977R

No.	Freq. (MHz)	Ant. Factor (dB/m)	Cable Loss (dB)	AMP factor (dB)	Reading (dBUV)	Emission Level (dBUV/m)	Limits (dBUV/m)	Margin (dB)	Remark
1	2474.000	27.95	7.47	36.59	100.87	99.70	74.00	-25.70	Peak
2	4948.000	32.15	9.52	35.47	38.76	44.96	54.00	9.04	Average
3	4948.000	32.15	9.52	35.47	49.01	55.21	74.00	18.79	Peak

Remarks: 1. Emission Level= Antenna Factor + Cable Loss + Reading - Amp Factor
 2. The emission levels that are 20dB below the official limit are not reported.

5. CONDUCTED SPURIOUS EMISSIONS

5.1. Test Equipment

Item	Equipment	Manufacturer	Model No.	Serial No.	Last Cal.	Cal. Interval
1.	Spectrum	Agilent	N9030A	MY51380221	Oct.17,15	1Year
2.	Attenuator (20dB)	Agilent	8491B	MY39262165	Apr.28,15	1 Year
3.	RF Cable	Marvelous Microwave Inc	SFL402105FLEX	NO.1	Oct.17,15	1 Year

5.2. Limit

In any 100kHz bandwidth outside the frequency bands in which the spread spectrum intentional radiator is operating, the radio frequency power that is produced by the intentional radiator shall be at least 20dB below that in the 100kHz bandwidth within the band that contains the highest level of the desired power.

5.3. Test Procedure

The transmitter output was connected to a spectrum analyzer, The resolution bandwidth is set to 100 kHz, The video bandwidth is set to 300 kHz and measure all the emissions With peak detector.

5.4. Test result

PASS (The testing data was attached in the next pages.)



2442MHz(10GHz-25GHz)

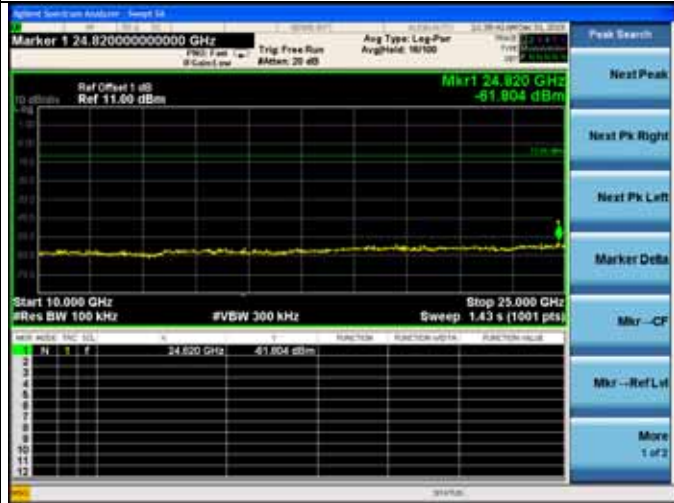

2474MHz(10GHz-25GHz)

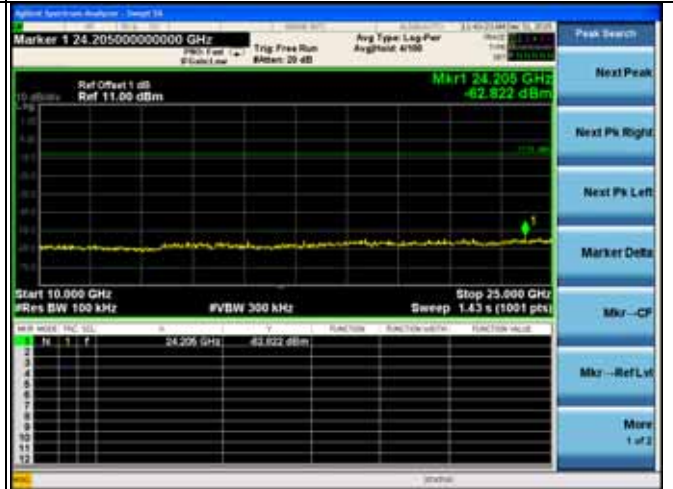

2474MHz(30MHz-1GHz)

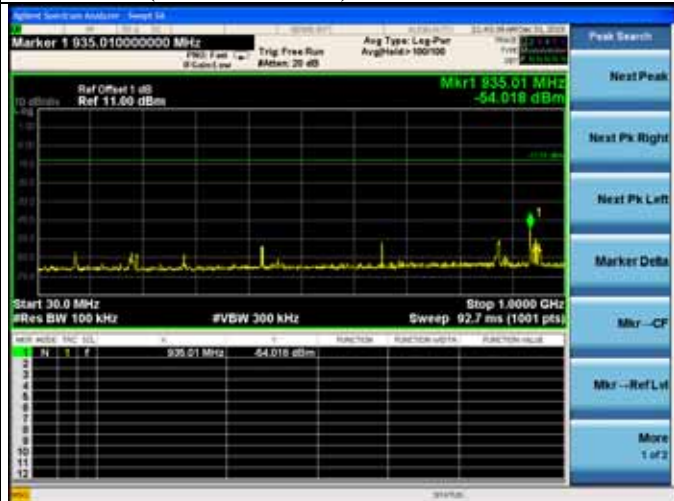

2474MHz(2.477GHz-2.51GHz)



2474MHz(1GHz-10GHz)

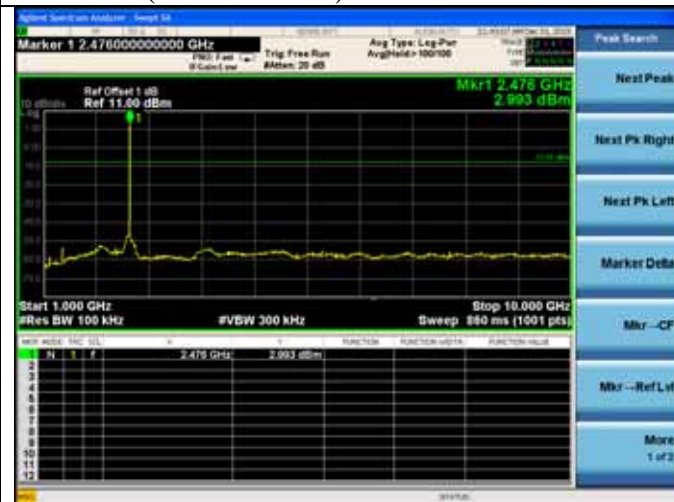

6. 6dB BANDWIDTH TEST

6.1. Test Equipment

Item	Equipment	Manufacturer	Model No.	Serial No.	Last Cal.	Cal. Interval
1.	Spectrum	Agilent	N9030A	MY51380221	Oct.17,15	1Year
2.	RF Cable	Marvelous Microwave Inc	SFL402105FLEX	NO.1	Oct.17.15	1 Year

6.2. Limit

For direct sequence systems, the minimum 6dB bandwidth shall be at least 500kHz.

6.3. Test Procedure

The transmitter output was connected to a spectrum analyzer, The bandwidth of the fundamental frequency was measured by spectrum analyzer with 100kHz RBW and 300KHz VBW. The 6dB bandwidth is defined as the total spectrum the power of which is higher than peak power minus 6dB.

6.4. Test Results

EUT: Katana HD 7.1 Base Station Receiver		
M/N: 90977R		
Test date: 2015-12-29	Pressure: 101.1±1.0 kpa	Humidity:52.7±3.0%
Tested by: Leo-Li	Test site: RF site	Temperature:22.8±0.6

Test Mode	Frequency (MHz)	6 dB bandwidth (kHz)	Limit (KHz)
Tx	2406	2154	500
	2442	2285	500
	2474	2144	500

Conclusion : PASS

<p>GFSK</p>	<p>2474MHz</p>																																								
<p>2406MHz</p> <table border="1"> <tr> <td>Center Freq</td> <td>2.406 GHz</td> <td>Total Power</td> <td>17.0 dBm</td> </tr> <tr> <td>Res BW</td> <td>30 kHz</td> <td>Occupied Bandwidth</td> <td>3.7215 MHz</td> </tr> <tr> <td>#VBW</td> <td>100 kHz</td> <td>Transmit Freq Error</td> <td>131.00 kHz</td> </tr> <tr> <td>Sweep</td> <td>10.8 ms</td> <td>OBW Power</td> <td>99.00 %</td> </tr> <tr> <td colspan="2">x dB Bandwidth</td> <td colspan="2">-6.00 dB</td> </tr> </table>	Center Freq	2.406 GHz	Total Power	17.0 dBm	Res BW	30 kHz	Occupied Bandwidth	3.7215 MHz	#VBW	100 kHz	Transmit Freq Error	131.00 kHz	Sweep	10.8 ms	OBW Power	99.00 %	x dB Bandwidth		-6.00 dB		<table border="1"> <tr> <td>Center Freq</td> <td>2.474 GHz</td> <td>Total Power</td> <td>15.3 dBm</td> </tr> <tr> <td>Res BW</td> <td>30 kHz</td> <td>Occupied Bandwidth</td> <td>3.6963 MHz</td> </tr> <tr> <td>#VBW</td> <td>100 kHz</td> <td>Transmit Freq Error</td> <td>-136.96 kHz</td> </tr> <tr> <td>Sweep</td> <td>10.8 ms</td> <td>OBW Power</td> <td>99.00 %</td> </tr> <tr> <td colspan="2">x dB Bandwidth</td> <td colspan="2">-6.00 dB</td> </tr> </table>	Center Freq	2.474 GHz	Total Power	15.3 dBm	Res BW	30 kHz	Occupied Bandwidth	3.6963 MHz	#VBW	100 kHz	Transmit Freq Error	-136.96 kHz	Sweep	10.8 ms	OBW Power	99.00 %	x dB Bandwidth		-6.00 dB	
Center Freq	2.406 GHz	Total Power	17.0 dBm																																						
Res BW	30 kHz	Occupied Bandwidth	3.7215 MHz																																						
#VBW	100 kHz	Transmit Freq Error	131.00 kHz																																						
Sweep	10.8 ms	OBW Power	99.00 %																																						
x dB Bandwidth		-6.00 dB																																							
Center Freq	2.474 GHz	Total Power	15.3 dBm																																						
Res BW	30 kHz	Occupied Bandwidth	3.6963 MHz																																						
#VBW	100 kHz	Transmit Freq Error	-136.96 kHz																																						
Sweep	10.8 ms	OBW Power	99.00 %																																						
x dB Bandwidth		-6.00 dB																																							
<p>2442MHz</p> <table border="1"> <tr> <td>Center Freq</td> <td>2.442 GHz</td> <td>Total Power</td> <td>16.2 dBm</td> </tr> <tr> <td>Res BW</td> <td>30 kHz</td> <td>Occupied Bandwidth</td> <td>3.6894 MHz</td> </tr> <tr> <td>#VBW</td> <td>100 kHz</td> <td>Transmit Freq Error</td> <td>-128.71 kHz</td> </tr> <tr> <td>Sweep</td> <td>10.8 ms</td> <td>OBW Power</td> <td>99.00 %</td> </tr> <tr> <td colspan="2">x dB Bandwidth</td> <td colspan="2">-6.00 dB</td> </tr> </table>	Center Freq	2.442 GHz	Total Power	16.2 dBm	Res BW	30 kHz	Occupied Bandwidth	3.6894 MHz	#VBW	100 kHz	Transmit Freq Error	-128.71 kHz	Sweep	10.8 ms	OBW Power	99.00 %	x dB Bandwidth		-6.00 dB																						
Center Freq	2.442 GHz	Total Power	16.2 dBm																																						
Res BW	30 kHz	Occupied Bandwidth	3.6894 MHz																																						
#VBW	100 kHz	Transmit Freq Error	-128.71 kHz																																						
Sweep	10.8 ms	OBW Power	99.00 %																																						
x dB Bandwidth		-6.00 dB																																							

7. MAXIMUM PEAK OUTPUT POWER TEST

7.1. Test Equipment

Item	Equipment	Manufacturer	Model No.	Serial No.	Last Cal.	Cal. Interval
1.	Spectrum	Agilent	N9030A	MY51380221	Oct.18,15	1Year
2.	Power meter	Anritsu	ML2487A	6K00002472	Aug.21,15	1Year
3.	Power sensor	Anritsu	MA2491A	0033005	Aug.21,15	1Year
4.	RF Cable	Marvelous Microwave Inc	SFL402105FLEX	NO.1	Oct.17,15	1 Year

7.2. Limit

For systems using digital modulation in the 2400—2483.5MHz, The Peak out put Power shall not exceed 1W(30dBm).

7.3. Test Procedure

Connected the EUT's antenna port to Power Sensor, and use power meter to test peak output power.

7.4. Test Results

EUT: Katana HD 7.1 Base Station Receiver			
M/N: 90977R			
Test date: 2015-12-29		Pressure: 101.4±1.0 kpa	Humidity:52.4±3.0%
Tested by: Leo-Li		Test site: RF site	Temperature:23.7±0.6
Test Mode	Frequency (MHz)	Peak output Power (dBm)	Limit (dBm)
Tx	2406	8.913	30
	2442	8.153	30
	2474	7.290	30
Conclusion: PASS			

8. BAND EDGE COMPLIANCE TEST

8.1. Test Equipment

Item	Equipment	Manufacturer	Model No.	Serial No.	Last Cal.	Cal. Interval
1.	Spectrum	Agilent	N9030A	MY51380221	Oct.18,15	1 Year
2.	Amp	HP	8449B	3008A02495	Apr.28,15	1 Year
3.	Horn Antenna	ETC	MCTD 1209	DRH15F03007	Feb.03,15	1 Year
4.	HF Cable	Hubersuhner	Sucoflex104	274094/4	Apr.28,15	1 Year

8.2. Limit

All the lower and upper band-edges emissions appearing within 2310MHz to 2390MHz and 2483.5MHz to 2500MHz restricted frequency bands shall not exceed the limits shown in 15.209, all the other emissions outside operation frequency band 2400MHz to 2483.5MHz shall be at least 20dB below the fundamental emissions, or comply with 15.209 limits.

8.3. Test Produce

For upper band emissions that are up to two bandwidths(2MHz) away (2483.5MHz to 2485.5MHz) from the band-edge use below produce:

1. Choose a spectrum analyzer span that encompasses both the peak of the fundamental emission and the band-edge emission under investigation. Set the analyzer RBW to 100KHz and with a video bandwidth 300KHz. Record the peak levels of the fundamental emission and the relevant band-edge emission, Observe the stored trace and measure the amplitude delta between the peak of the fundamental and the peak of the band-edge emission. This is not a field strength measurement, it is only a relative measurement to determine the amount by which the emission drops at the band edge relative to the highest fundamental emission level.
2. Subtract the delta measured in step (1) from the maximum field strengths measured in clause 4 .The resultant field strengths are then used to determine band-edge compliance as required by Section 15.205

For emissions above two bandwidths away from the band-edge use below produce:

1. The EUT is placed on a turntable, which is 0.8m above the ground plane and worked at highest radiated power.
2. The turntable was rotated for 360 degrees to determine the position of maximum emission level.
3. EUT is set 3m away from the receiving antenna, which is varied from 1m to 4m to find out the highest emission.
4. Set the spectrum analyzer in the following setting in order to capture the lower and upperband-edges of the emission:
 - (a) PEAK: RBW=1MHz; VBW=3MHz, PK detector, Sweep=AUTO
 - (b) Average: RBW=1MHz; VBW=10MHz, Sweep=AUTO

8.4. Test Results

Pass (The testing data was attached in the next pages.)

Note: If the PK measured levels comply with average limit, then the average level were deemed to comply with average limit.

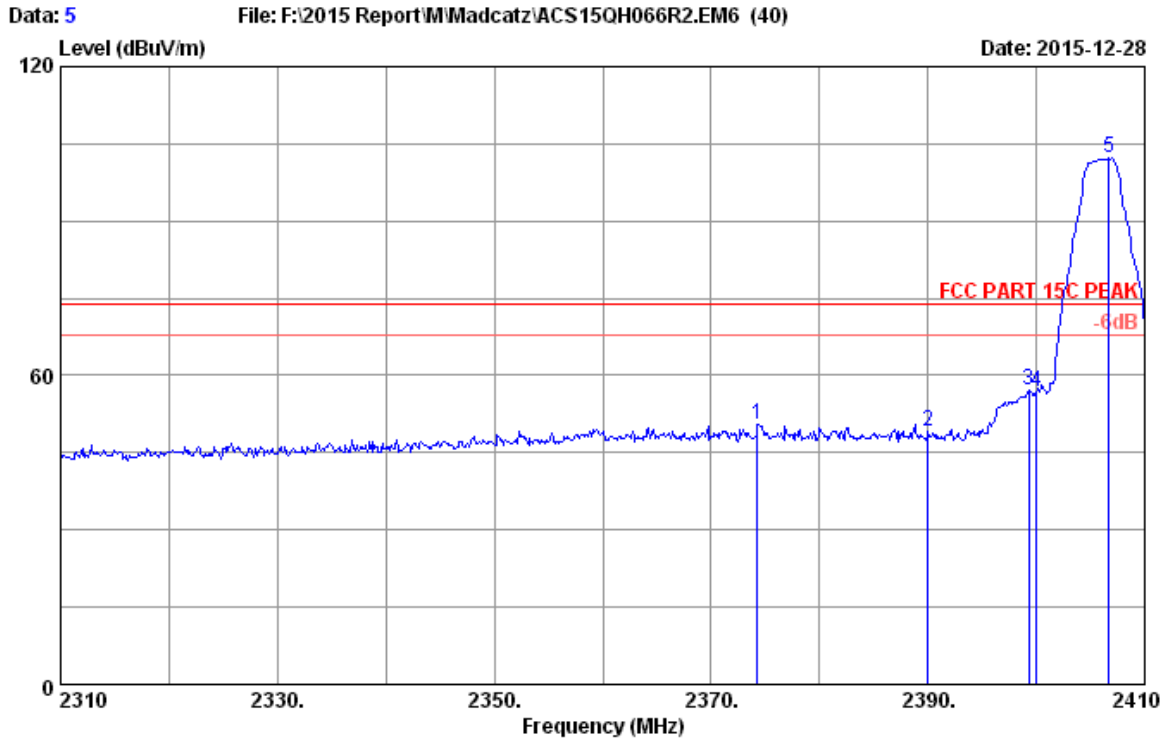

Site no. : 3m Chamber Data no. : 5
 Dis. / Ant. : 3m 2015 MCTD1209 3007 Ant. pol. : HORIZONTAL
 Limit : FCC PART 15C PEAK
 Env. / Ins. : 23.4°C/53.2%
 Engineer : Leo-Li
 EUT : Katana HD 7.1 Base Station Receiver
 Power rating : DC 5V From PC Input AC 120V/60Hz
 Test Mode : 2406MHz Tx
 90977R

No.	Freq. (MHz)	Ant. Factor (dB/m)	Cable Loss (dB)	AMP factor (dB)	Reading (dBuV)	Emission Level (dBuV/m)	Limits (dBuV/m)	Margin (dB)	Remark
1	2374.300	27.75	7.24	36.63	52.10	50.46	74.00	23.54	Peak
2	2390.000	27.78	7.28	36.62	50.53	48.97	74.00	25.03	Peak
3	2399.300	27.80	7.32	36.62	58.56	57.06	74.00	16.94	Peak
4	2400.000	27.80	7.32	36.62	58.42	56.92	74.00	17.08	Peak
5	2406.700	27.81	7.32	36.62	103.69	102.20	74.00	-28.20	Peak

Remarks: 1. Emission Level= Antenna Factor + Cable Loss + Reading - Amp Factor
 2. The emission levels that are 20dB below the official limit are not reported.

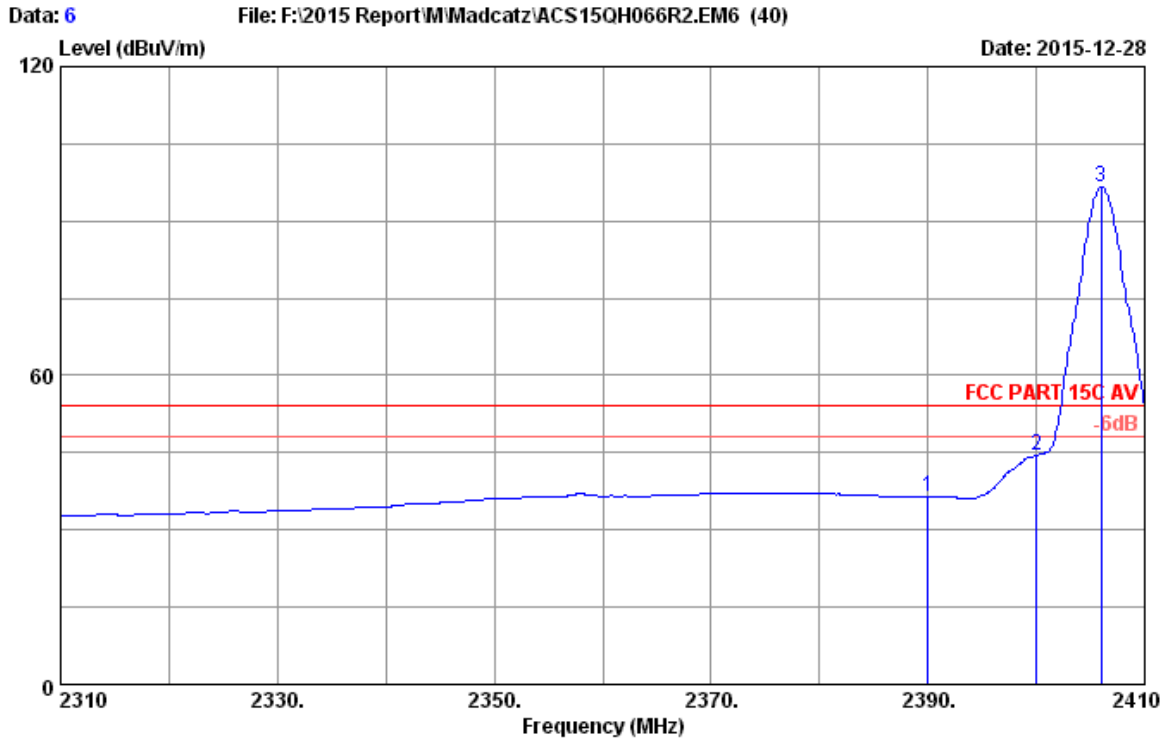

Site no. : 3m Chamber Data no. : 6
 Dis. / Ant. : 3m 2015 MCTD1209 3007 Ant. pol. : HORIZONTAL
 Limit : FCC PART 15C AV
 Env. / Ins. : 23.4°C/53.2%
 Engineer : Leo-Li
 EUT : Katana HD 7.1 Base Station Receiver
 Power rating : DC 5V From PC Input AC 120V/60Hz
 Test Mode : 2406MHz Tx
 90977R

No.	Freq. (MHz)	Ant. Factor (dB/m)	Cable Loss (dB)	AMP factor (dB)	Reading (dBuV)	Emission Level (dBuV/m)	Limits (dBuV/m)	Margin (dB)	Remark
1	2390.000	27.78	7.28	36.62	37.95	36.39	54.00	17.61	Average
2	2400.000	27.80	7.32	36.62	45.92	44.42	54.00	9.58	Average
3	2406.000	27.81	7.32	36.62	98.25	96.76	54.00	-42.76	Average

Remarks: 1. Emission Level= Antenna Factor + Cable Loss + Reading
 -Amp Factor
 2. The emission levels that are 20dB below the official limit are not reported.

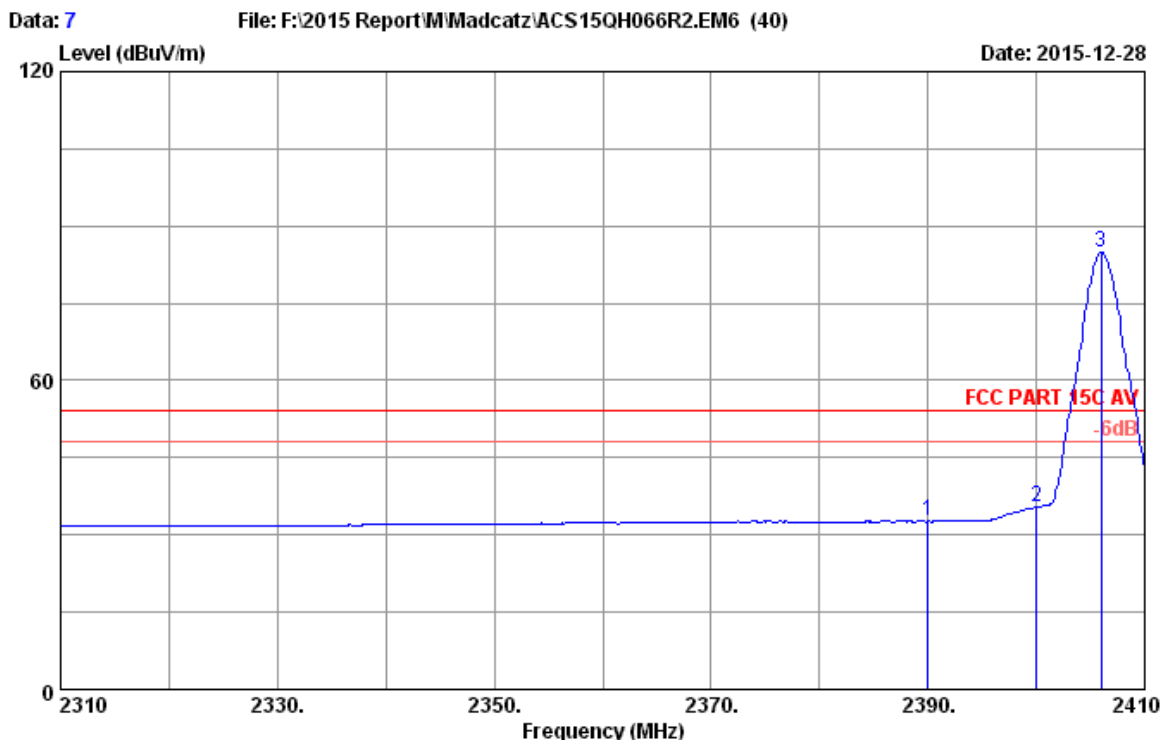

Site no. : 3m Chamber Data no. : 7
 Dis. / Ant. : 3m 2015 MCTD1209 3007 Ant. pol. : VERTICAL
 Limit : FCC PART 15C AV
 Env. / Ins. : 23.4*C/53.2%
 Engineer : Leo-Li
 EUT : Katana HD 7.1 Base Station Receiver
 Power rating : DC 5V From PC Input AC 120V/60Hz
 Test Mode : 2406MHz Tx
 90977R

No.	Freq. (MHz)	Ant. Factor (dB/m)	Cable Loss (dB)	AMP factor (dB)	Reading (dBuV)	Emission Level (dBuV/m)	Limits (dBuV/m)	Margin (dB)	Remark
1	2390.000	27.78	7.28	36.62	34.16	32.60	54.00	21.40	Average
2	2400.000	27.80	7.32	36.62	36.86	35.36	54.00	18.64	Average
3	2406.000	27.81	7.32	36.62	86.39	84.90	54.00	-30.90	Average

Remarks: 1. Emission Level= Antenna Factor + Cable Loss + Reading - Amp Factor
 2. The emission levels that are 20dB below the official limit are not reported.

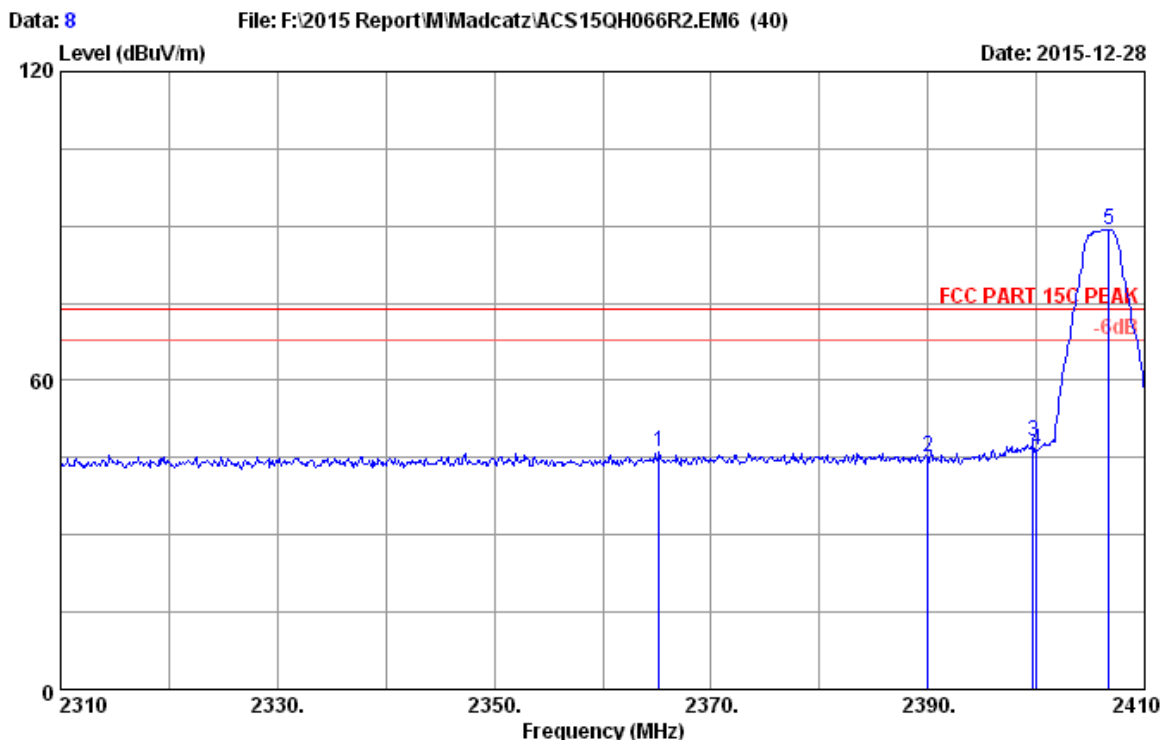

Site no. : 3m Chamber Data no. : 8
 Dis. / Ant. : 3m 2015 MCTD1209 3007 Ant. pol. : VERTICAL
 Limit : FCC PART 15C PEAK
 Env. / Ins. : 23.4°C/53.2%
 Engineer : Leo-Li
 EUT : Katana HD 7.1 Base Station Receiver
 Power rating : DC 5V From PC Input AC 120V/60Hz
 Test Mode : 2406MHz Tx
 90977R

No.	Freq. (MHz)	Ant. Factor (dB/m)	Cable Loss (dB)	AMP factor (dB)	Reading (dBuV)	Emission Level (dBuV/m)	Limits (dBuV/m)	Margin (dB)	Remark
1	2365.200	27.73	7.24	36.63	47.70	46.04	74.00	27.96	Peak
2	2390.000	27.78	7.28	36.62	46.76	45.20	74.00	28.80	Peak
3	2399.700	27.80	7.32	36.62	49.74	48.24	74.00	25.76	Peak
4	2400.000	27.80	7.32	36.62	48.11	46.61	74.00	27.39	Peak
5	2406.700	27.81	7.32	36.62	90.83	89.34	74.00	-15.34	Peak

Remarks: 1. Emission Level= Antenna Factor + Cable Loss + Reading - Amp Factor
 2. The emission levels that are 20dB below the official limit are not reported.

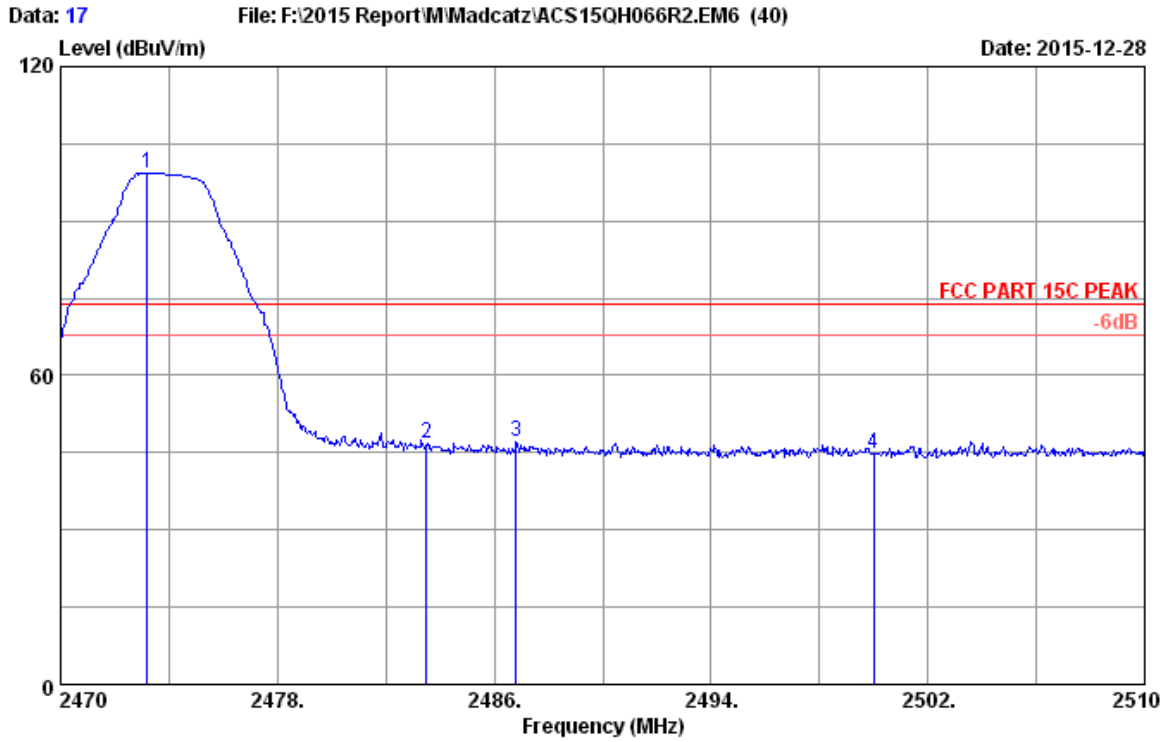

Site no. : 3m Chamber Data no. : 17
 Dis. / Ant. : 3m 2015 MCTD1209 3007 Ant. pol. : HORIZONTAL
 Limit : FCC PART 15C PEAK
 Env. / Ins. : 23.4°C/53.2%
 Engineer : Leo-Li
 EUT : Katana HD 7.1 Base Station Receiver
 Power rating : DC 5V From PC Input AC 120V/60Hz
 Test Mode : 2474MHz Tx
 90977R

No.	Freq. (MHz)	Ant. Factor (dB/m)	Cable Loss (dB)	AMP factor (dB)	Reading (dBuV)	Emission Level (dBuV/m)	Limits (dBuV/m)	Margin (dB)	Remark
1	2473.200	27.95	7.47	36.59	100.52	99.35	74.00	-25.35	Peak
2	2483.500	27.97	7.51	36.59	48.05	46.94	74.00	27.06	Peak
3	2486.800	27.97	7.51	36.59	48.22	47.11	74.00	26.89	Peak
4	2500.000	28.00	7.51	36.58	45.76	44.69	74.00	29.31	Peak

Remarks: 1. Emission Level= Antenna Factor + Cable Loss + Reading
 -Amp Factor
 2. The emission levels that are 20dB below the official
 limit are not reported.

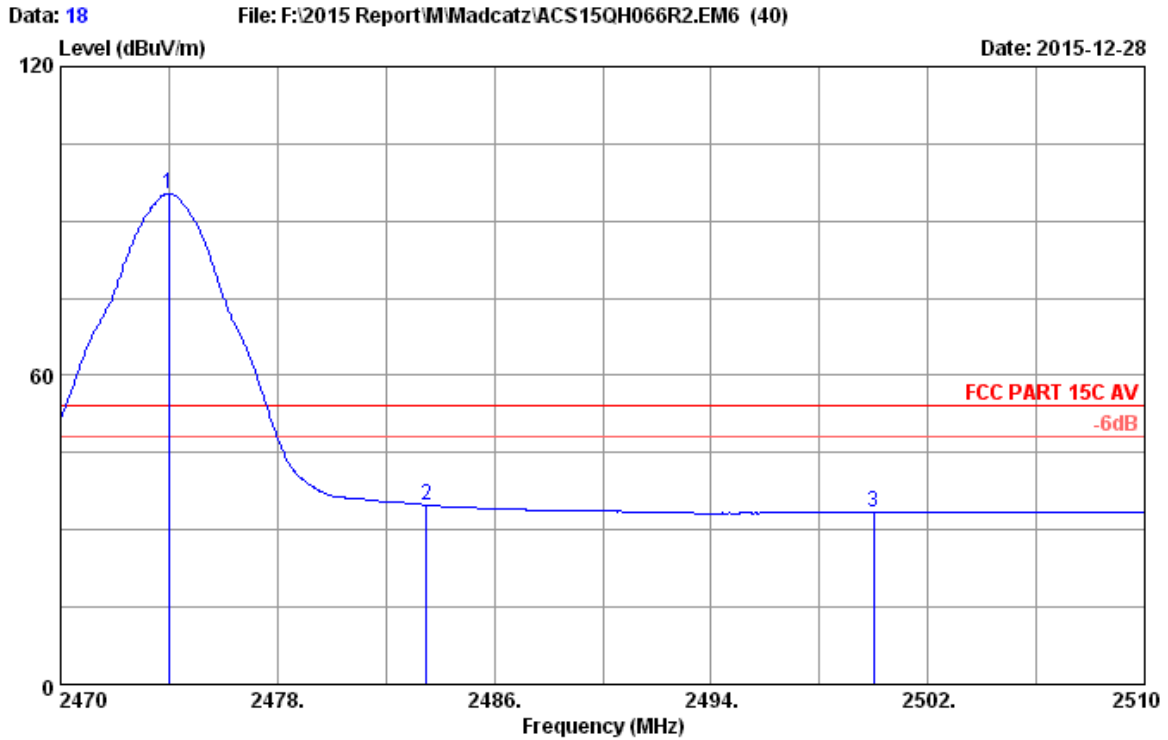

Site no. : 3m Chamber Data no. : 18
 Dis. / Ant. : 3m 2015 MCTD1209 3007 Ant. pol. : HORIZONTAL
 Limit : FCC PART 15C AV
 Env. / Ins. : 23.4°C/53.2%
 Engineer : Leo-Li
 EUT : Katana HD 7.1 Base Station Receiver
 Power rating : DC 5V From PC Input AC 120V/60Hz
 Test Mode : 2474MHz Tx
 90977R

No.	Freq. (MHz)	Ant. Factor (dB/m)	Cable Loss (dB)	AMP factor (dB)	Reading (dBuV)	Emission Level (dBuV/m)	Limits (dBuV/m)	Margin (dB)	Remark
1	2474.000	27.95	7.47	36.59	96.55	95.38	54.00	-41.38	Average
2	2483.500	27.97	7.51	36.59	35.95	34.84	54.00	19.16	Average
3	2500.000	28.00	7.51	36.58	34.43	33.36	54.00	20.64	Average

Remarks: 1. Emission Level= Antenna Factor + Cable Loss + Reading -Amp Factor
 2. The emission levels that are 20dB below the official limit are not reported.

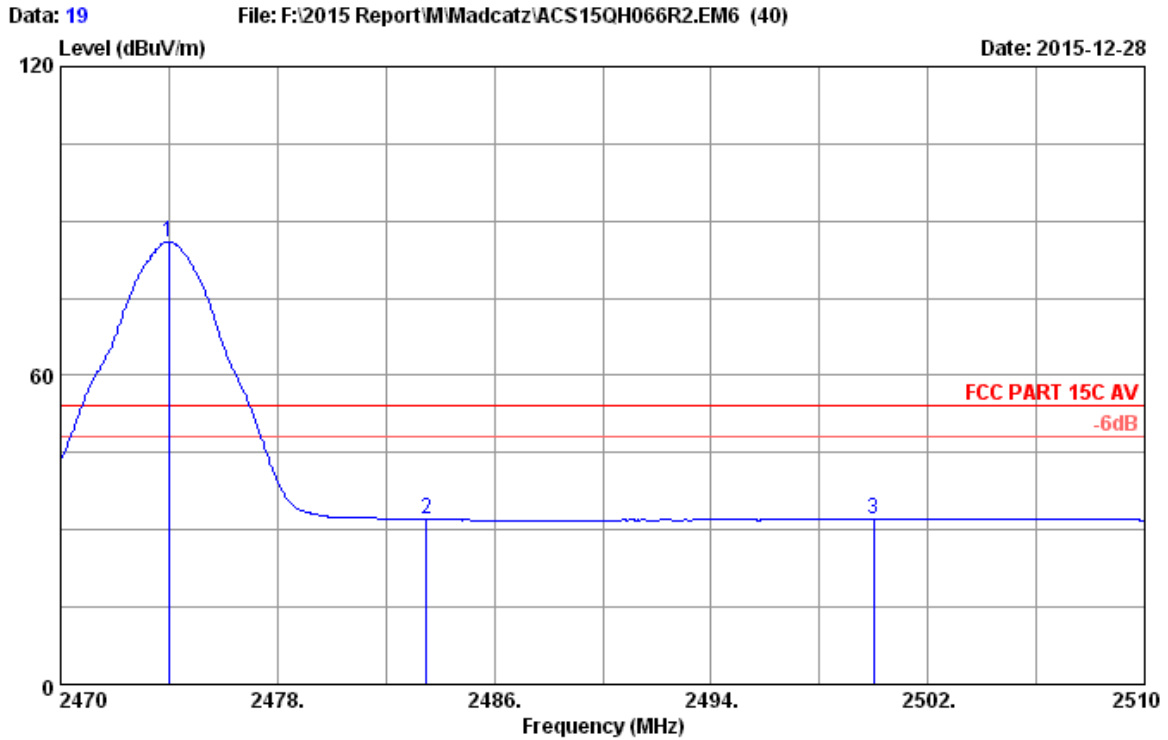

Site no. : 3m Chamber Data no. : 19
 Dis. / Ant. : 3m 2015 MCTD1209 3007 Ant. pol. : VERTICAL
 Limit : FCC PART 15C AV
 Env. / Ins. : 23.4°C/53.2%
 Engineer : Leo-Li
 EUT : Katana HD 7.1 Base Station Receiver
 Power rating : DC 5V From PC Input AC 120V/60Hz
 Test Mode : 2474MHz Tx
 90977R

No.	Freq. (MHz)	Ant. Factor (dB/m)	Cable Loss (dB)	AMP factor (dB)	Reading (dBuV)	Emission Level (dBuV/m)	Limits (dBuV/m)	Margin (dB)	Remark
1	2474.000	27.95	7.47	36.59	87.20	86.03	54.00	-32.03	Average
2	2483.500	27.97	7.51	36.59	33.16	32.05	54.00	21.95	Average
3	2500.000	28.00	7.51	36.58	33.09	32.02	54.00	21.98	Average

Remarks: 1. Emission Level= Antenna Factor + Cable Loss + Reading - Amp Factor
 2. The emission levels that are 20dB below the official limit are not reported.

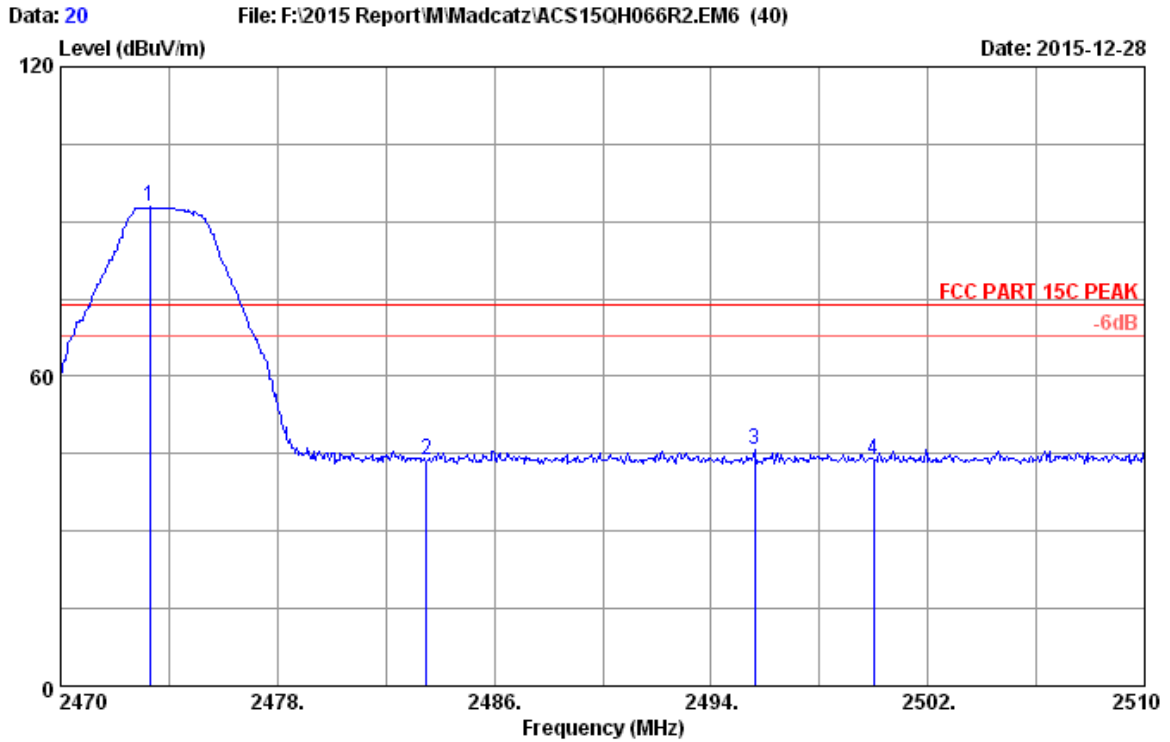

Site no. : 3m Chamber Data no. : 20
 Dis. / Ant. : 3m 2015 MCTD1209 3007 Ant. pol. : VERTICAL
 Limit : FCC PART 15C PEAK
 Env. / Ins. : 23.4°C/53.2%
 Engineer : Leo-Li
 EUT : Katana HD 7.1 Base Station Receiver
 Power rating : DC 5V From PC Input AC 120V/60Hz
 Test Mode : 2474MHz Tx
 90977R

No.	Freq. (MHz)	Ant. Factor (dB/m)	Cable Loss (dB)	AMP factor (dB)	Reading (dBuV)	Emission Level (dBuV/m)	Limits (dBuV/m)	Margin (dB)	Remark
1	2473.280	27.95	7.47	36.59	93.93	92.76	74.00	-18.76	Peak
2	2483.500	27.97	7.51	36.59	44.74	43.63	74.00	30.37	Peak
3	2495.600	27.99	7.51	36.58	46.74	45.66	74.00	28.34	Peak
4	2500.000	28.00	7.51	36.58	44.77	43.70	74.00	30.30	Peak

Remarks: 1. Emission Level= Antenna Factor + Cable Loss + Reading - Amp Factor
 2. The emission levels that are 20dB below the official limit are not reported.

9. POWER SPECTRAL DENSITY TEST

9.1. Test Equipment

Item	Equipment	Manufacturer	Model No.	Serial No.	Last Cal.	Cal. Interval
1.	Spectrum	Agilent	N9030A	MY51380221	Oct.18,15	1 Year
2.	RF Cable	Marvelous Microwave Inc	SFL402105FLEX	NO.1	Oct.17,15	1 Year

9.2. Limit

For digitally modulated systems, the power spectral density conducted from the intentional radiator to the antenna shall not be greater than 8dBm in any 3kHz band during any time interval of continuous transmission.

9.3. Test Procedure

1. Connected the EUT's antenna port to spectrum analyzer device by 20dB attenuator.
2. Set the test frequency as center frequency, Set RBW=3KHz,VBW=10KHz,Span large enough capture the entire frequency, Read out maximum peak level frequency
3. Set the span to 1.5 times of the DTS Bandwidth Detector= Peak; Sweep time= Auto Couple; Trace Mode= Max hold.
4. Allow trace to fully stabilize use the peak marker function to determine the maximum amplitude level within the RBW.

Note: The cable loss and attenuator loss were offset into measure device as an amplitude

9.4. Test Results

EUT: Katana HD 7.1 Base Station Receiver		
M/N: 90977R		
Test date: 2015-12-29	Pressure: 101.2±1.0 kpa	Humidity:53.6±3.0%
Tested by: Leo-Li	Test site: RF site	Temperature:23.2±0.6

Test Mode	Frequency (MHz)	Power density (dBm/3KHz)	Limit (dBm/3KHz)
Tx	2406	-8.551	8
	2442	-10.121	8
	2474	-10.684	8

Conclusion : PASS

GFSK

2406MHz



2474MHz

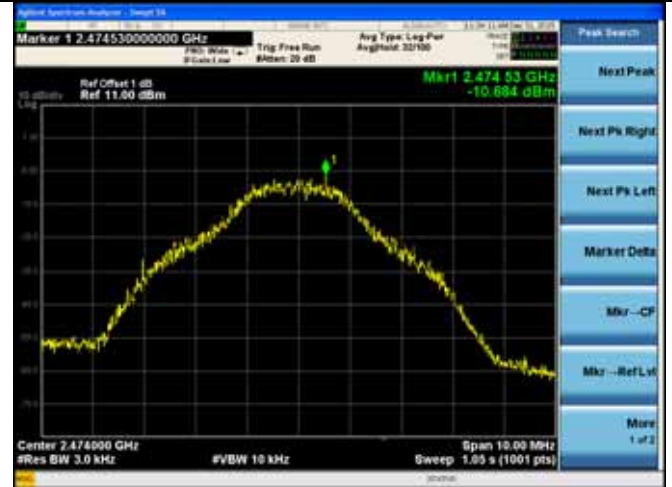

2442MHz



10. ANTENNA REQUIREMENT

10.1. STANDARD APPLICABLE

For intentional device, according to FCC 47 CFR Section 15.203, an intentional radiator shall be designed to ensure that no antenna other than that furnished by the responsible party shall be used with the device. And according to FCC 47 CFR Section 15.247 (b), if transmitting antennas of directional gain greater than 6dBi are used, the power shall be reduced by the amount in dB that the directional gain of the antenna exceeds 6dBi.

10.2. ANTENNA CONNECTED CONSTRUCTION

The antennas used for this product are Integrated PCB Antenna that no antenna other than that furnished by the responsible party shall be used with the device, the maximum peak gain of the transmit antenna is 3.7874dBi.

11. DEVIATION TO TEST SPECIFICATIONS

[NONE]