

APPLICATION FOR CERTIFICATION

On Behalf of

Mad Catz, Inc.

EUT Description	Model Number
PS3 Wireless Stratocaster guitar controller	9756
PS3 Wireless American P-Bass guitar controller	9766

FCC ID: P25G0MC9766S0709R

Prepared for : Mad Catz, Inc.
7480 Mission Valley Road, Suite 101, San Diego,
California, 92108

Prepared By : Audix Technology (Shenzhen) Co., Ltd.
No. 6, Ke Feng Rd., 52 Block,
Shenzhen Science & Industrial Park,
Nantou, Shenzhen, Guangdong, China

Tel: (0755) 26639496

Report Number : ACS-F09035
Date of Test : Feb.05~24, 2009
Date of Report : Mar.03, 2009

TABLE OF CONTENTS

Description	Page
1. SUMMARY OF STANDARDS AND RESULTS	1-1
1.1. Description of Standards and Results.....	1-1
2. GENERAL INFORMATION	2-1
2.1. Description of Device (EUT)	2-1
2.2. Tested Supporting System Details	2-1
2.3. Test Facility.....	2-2
2.4. Test Uncertainty(95% confidence levels, k=2)	2-2
3. POWER LINE CONDUCTED EMISSION TEST	3-1
3.1. Test Equipments.....	3-1
3.2. Block Diagram of Test Setup.....	3-1
3.3. Power Line Conducted Emission Test Limits	3-1
3.4. Configuration of EUT on Test	3-1
3.5. Operating Condition of EUT.....	3-2
3.6. Test Procedure.....	3-2
3.7. Power Line Conducted Emission Test Results.....	3-2
4. RADIATED EMISSION TEST	4-1
4.1. Test Equipment	4-1
4.2. Block Diagram of Test Setup.....	4-1
4.3. Radiated Emission Limit Standard: FCC 15.209 and 15.249	4-2
4.4. EUT Configuration on Test.....	4-3
4.5. Operating Condition of EUT.....	4-3
4.6. Test Procedure.....	4-3
4.7. Radiated Emission Test Results	4-3
5. BAND EDGE COMPLIANCE TEST	5-1
5.1. Test Equipment	5-1
5.2. Limit.....	5-1
5.3. Test Produce	5-1
5.4. Test Results	5-1
6. 20DB BANDWIDTH TEST	6-5
6.1. Test Equipment	6-5
6.2. Limit.....	6-5
6.3. Test Results	6-5
7. DEVIATION TO TEST SPECIFICATIONS	7-5
8. PHOTOGRAPH OF TEST	8-5
8.1. Photos of Power Line Conducted Emission Test	8-5
8.2. Photos of Radiated Emission Test (In Anechoic Chamber).....	8-5
9. PHOTOGRAPH OF EUT	9-5

TEST REPORT CERTIFICATION

Applicant : Mad Catz, Inc.

EUT Description &
Model No.

EUT Description	Model Number
PS3 Wireless Stratocaster guitar controller	9756
PS3 Wireless American P-Bass guitar controller	9766

FCC ID : P25G0MC9766S0709R

Power Supply : DC 5V

Test Voltage : DC 5V From PS3 Input AC 120V/60Hz

Test Procedure Used:

FCC Rules and Regulations Part 15 Subpart C 2008

The device described above is tested by Audix Technology (Shenzhen) Co., Ltd. to determine the maximum emission levels emanating from the device. The maximum emission levels are compared to the FCC Part 15 Subpart C limits for radiated and conducted emissions.

The test results are contained in this test report and Audix Technology (Shenzhen) Co., Ltd. is assumed full responsibility for the accuracy and completeness of tests. Also, this report shows that EUT is technically compliant with FCC requirements.

This report applies to above tested sample only. This report shall not be reproduced in part without written approval of Audix Technology (Shenzhen) Co., Ltd.

Date of Test :

Feb.05~ 24, 2009

Prepared by :

Edie Huang
Edie Huang / Assistant

Reviewer :

Jamy Yu
Jamy Yu / Senior Engineer

Approved & Authorized Signer :

Ken Lu
Ken Lu / Manager



1. SUMMARY OF STANDARDS AND RESULTS

1.1. Description of Standards and Results

The EUT have been tested according to the applicable standards as referenced below.

EMISSION		
Description of Test Item	Standard	Results
Power Line Conducted Emission Test	FCC Part 15C: 15.207 ANSI C63.4-2003	PASS
Radiated Emission Test	FCC Part 15C: 15.209 FCC Part 15C: 15.249 ANSI C63.4-2003	PASS
Band Edge Compliance Test	FCC Part 15: 15.249	PASS
20dB Bandwidth Test	FCC Part 15: 15.215	PASS

2. GENERAL INFORMATION

2.1. Description of Device (EUT)

Product Name & Model Number	EUT Description	Model Number
	PS3 Wireless Stratocaster guitar controller	9756
	PS3 Wireless American P-Bass guitar controller	9766

The size and appearance are different only.

Test Model No.: 9766

FCC ID : P25G0MC9766S0709R

Operation frequency : 2403MHz~2480MHz

Power Supply : DC 5V From PS3
(The supply voltage was varied between 85% and 115% of the nominal rated (120V/60Hz) supply voltage. And all the emissions include fundamental emissions had no change. So only the nominal power supply test data were recorded.)

Applicant : Mad Catz, Inc.
7480 Mission Valley Road, Suite 101, San Diego, California, 92108

Date of Test : Feb.05~24, 2009

Date of Receipt : Feb.04, 2009

Sample Type : Prototype production

Note: This EUT has two parts, one is guitar, the other one is dongle. We test dongle in this report.

2.2. Tested Supporting System Details

2.2.1.TV

EMC CODE : ACS-EMC-TV01T
M/N : 1419A
Manufacturer : TCL
Power cord : Unshielded,Undetachabled, 1.8m

2.2.2.PS3

Manufacturer : SONY
M/N : CECHC04

2.3. Test Facility

Site Description

- Name of Firm : Audix Technology (Shenzhen) Co., Ltd.
No. 6, Ke Feng Rd., 52 Block, Shenzhen Science & Industrial Park, Nantou, Shenzhen, Guangdong, China
- 3m Anechoic Chamber : Jun. 13, 2006 File on Federal Communication Commission
Registration Number: 90454
- 3m & 10m Anechoic Chamber : Jan. 31, 2007 File on Federal Communication Commission
Registration Number: 794232
- EMC Lab. : Accredited by DATech, German
Registration Number: DAT-P-091/99-01
Feb. 02, 2009
- Accredited by NVLAP, USA
NVLAP Code: 200372-0
Apr.01, 2008

2.4. Test Uncertainty(95% confidence levels, k=2)

Item	MU	Remark
Uncertainty for Power point Conducted Emissions Test	2.88dB	
Uncertainty for Radiation Emission test in 3m chamber (30MHz to 1GHz)	3.86dB	Polarize: V
	4.3dB	Polarize: H
Uncertainty for Radiation Emission test in 3m chamber (1GHz to 25GHz)	2.78dB	Polarize: H
	2.82dB	Polarize: V

3. POWER LINE CONDUCTED EMISSION TEST

3.1. Test Equipments

Item	Equipment	Manufacturer	Model No.	Serial No.	Last Cal.	Cal. Interval
1.	Test Receiver	Rohde & Schwarz	ESCI	100843	Oct.24, 08	1 Year
2.	L.I.S.N.#2	Kyoritsu	KNW-407	8-1636-1	May 10,08	1 Year
3.	L.I.S.N.#3	Kyoritsu	KNW-242C	8-1920-1	May 10,08	1 Year
4.	Terminator	Hubersuhner	50Ω	No. 1	May 10,08	1 Year
5.	RF Cable	Fujikura	3D-2W	LISN Cable 1#	Nov.10, 08	1/2 Year
6.	Coaxial Switch	Anritsu	MP59B	M55367	Nov.10, 08	1/2 Year
7.	Pulse Limiter	Rohde & Schwarz	ESH3-Z2	100341	Nov.10, 08	1/2 Year

3.2. Block Diagram of Test Setup

3.2.1. Block diagram of connection between the EUT and simulators

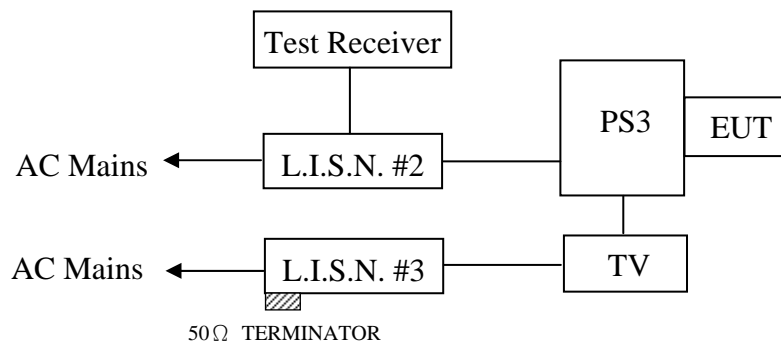

(EUT: PS3 Wireless American P-Bass guitar controller)

3.3. Power Line Conducted Emission Test Limits

Frequency	Maximum RF Line Voltage	
	Quasi-Peak Level dB(μV)	Average Level dB(μV)
150kHz ~ 500kHz	66 ~ 56*	56 ~ 46*
500kHz ~ 5MHz	56	46
5MHz ~ 30MHz	60	50

Notes: 1. * Decreasing linearly with logarithm of frequency.

2. The lower limit shall apply at the transition frequencies.

3.4. Configuration of EUT on Test

The following equipment are installed on Power Line Conducted Emission Test to meet the commission requirement and operating regulations in a manner which tends to maximize its emission characteristics in a normal application.

3.4.1. PS3 Wireless American P-Bass guitar controller (EUT)

Model Number : 9766

Serial Number : N/A

3.4.2. Support Equipment: As Tested Supporting System Detail, in Section 2.2..

3.5. Operating Condition of EUT

3.5.1. Setup the EUT as shown in Section 3.2..

3.5.2. Let the EUT work in test mode (Running) and test it.

3.6. Test Procedure

The EUT was placed on a non-metallic table, 80cm above the ground plane. The EUT Power Via PS3 connected to the power mains through a line impedance stabilization network (L.I.S.N. 2#). This provides a 50 ohm coupling impedance for the EUT (Please refer the block diagram of the test setup and photographs). The other peripheral devices power cord connected to the power mains through a line impedance stabilization network (L.I.S.N.#3). Power on the PS3 and let it work normally, we use a test software, let EUT working in test mode, then test it. Both sides of AC line are checked to find out the maximum conducted emission. In order to find the maximum emission levels, the relative positions of equipment and all of the interface cables shall be changed according to ANSI C63.4: 2003 on Conducted Emission Test.

The bandwidth of test receiver (R & S ESCI) is set at 10kHz.

The frequency range from 150kHz to 30MHz is checked.

The test result are reported on Section 3.7.

3.7. Power Line Conducted Emission Test Results

PASS. (All emissions not reported below are too low against the prescribed limits.)



NO.6 Ke Feng Road,Block 52,
Shenzhen Science&Industry Park
Nantou, Shenzhen,Guang dong, China.
Tel:+86-755-26639495
Fax:+86-755-26632877
Postcode:518057

Data: 3

File: D:\DATA\2009 Report\M\ACS9QH026\ACS9QH026.EM6 (4)

Date: 2009-02-05

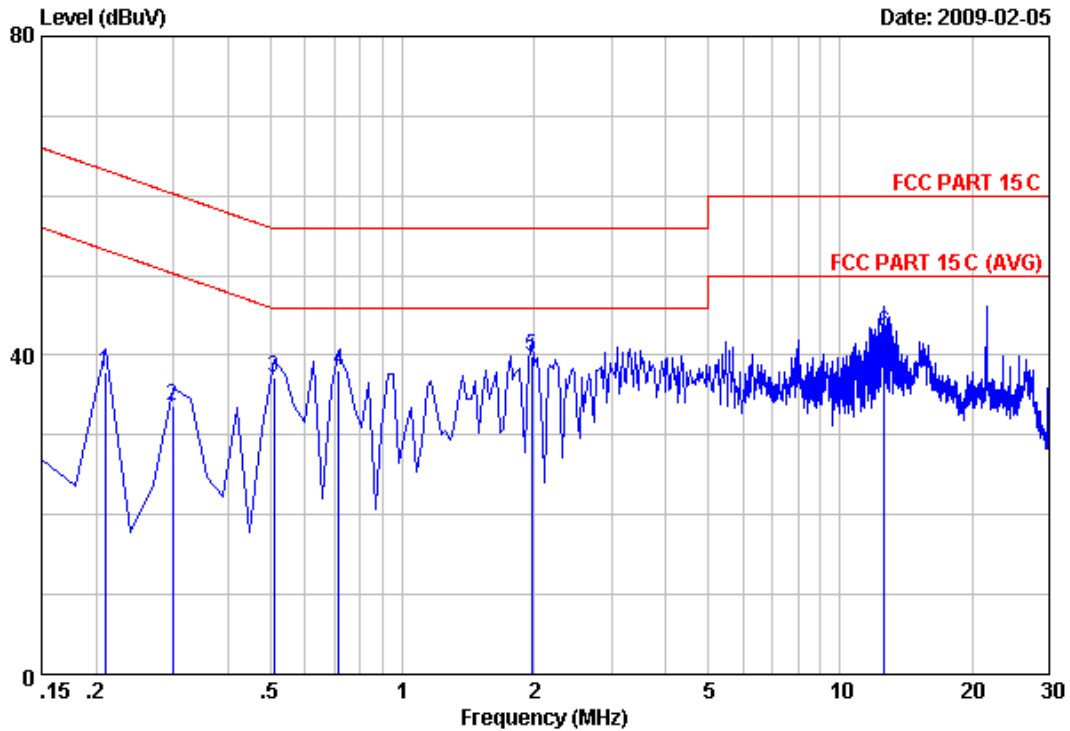

Site no :Audix No.1 Conduction Data no :3
 Dis./Ant. **: KNW407 1# VA LISN phase:
 Limit :FCC PART 15 C
 Env./Ins. :Temp:23'C Humi:54% Engineer :LUCK
 EUT :PS3 Wireless American P-Bass guitar controller
 Power Rating :DC 5V from PS3 input AC 120V/60Hz
 Test Mode :Running
 M/N : 9766 (Dongle)

No	Freq (MHz)	LISN Factor (dB)	Cable Loss (dB)	Reading (dBuV)	Emission Level (dBuV)	Limits (dBuV)	Margin (dB)	Remark
1	0.20970	0.29	9.91	27.61	37.81	63.22	25.41	QP
2	0.29925	0.26	9.89	23.51	33.66	60.26	26.60	QP
3	0.50820	0.20	9.87	27.18	37.25	56.00	18.75	QP
4	0.71715	0.19	9.88	27.99	38.06	56.00	17.94	QP
5	1.971	0.10	9.90	29.81	39.81	56.00	16.19	QP
6	12.627	0.26	10.01	32.42	42.69	60.00	17.31	QP

Remarks: 1.Emission Level=LISN Factor+Cable Loss(Include 10dB pulse limit)+Reading
 2.If the average limit is met when using a quasi-peak detector.
 the EUT shall be deemed to meet both limits and measurement
 with average detector is unnecessary.



NO.6 Ke Feng Road,Block 52,
Shenzhen Science&Industry Park
Nantou, Shenzhen,Guang dong, China.
Tel:+86-755-26639495
Fax:+86-755-26632877
Postcode:518057

Data: 4

File: D:\DATA\2009 Report\M\ACS9QH026\ACS9QH026.EM6 (4)

Date: 2009-02-05

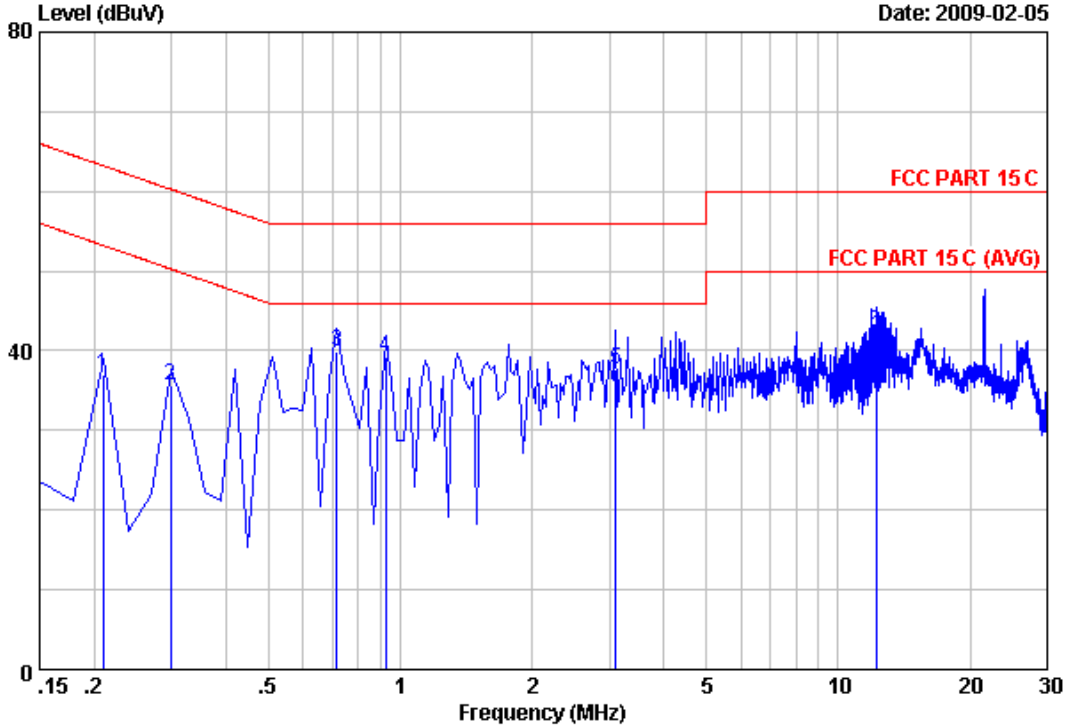

Site no :Audix No.1 Conduction Data no :4
 Dis./Ant. **: KNW407 1# VB LISN phase:
 Limit :FCC PART 15 C
 Env./Ins. :Temp:23'C Humi:54% Engineer :LUCK
 EUT :PS3 Wireless American P-Bass guitar controller
 Power Rating :DC 5V from PS3 input AC 120V/60Hz
 Test Mode :Running
 M/N : 9766 (Dongle)

No	Freq (MHz)	LISN Factor (dB)	Cable Loss (dB)	Reading (dBuV)	Emission Level (dBuV)	Limits (dBuV)	Margin (dB)	Remark
1	0.20970	0.11	9.91	27.03	37.05	63.22	26.17	QP
2	0.29925	0.14	9.89	25.57	35.60	60.26	24.66	QP
3	0.71715	0.10	9.88	29.82	39.80	56.00	16.20	QP
4	0.92610	0.10	9.89	29.14	39.13	56.00	16.87	QP
5	3.105	0.03	9.91	27.62	37.56	56.00	18.44	QP
6	12.209	0.18	10.00	32.26	42.44	60.00	17.56	QP

Remarks: 1.Emission Level=LISN Factor+Cable Loss(Include 10dB pulse limit)+Reading
 2.If the average limit is met when using a quasi-peak detector,
 the EUT shall be deemed to meet both limits and measurement
 with average detector is unnecessary.

4. RADIATED EMISSION TEST

4.1. Test Equipment

Frequency rang: 30~1000MHz

Item	Equipment	Manufacturer	Model No.	Serial No.	Last Cal.	Cal. Interval
1.	3#Chamber	AUDIX	N/A	N/A	Dec.05,08	1/2 Year
2.	EMI Spectrum	Agilent	E4407B	MY41440292	May 10, 08	1 Year
3.	Test Receiver	Rohde & Schwarz	ESVS10	834468/011	May 10, 08	1 Year
4.	Amplifier	HP	8447D	2648A04738	Nov.04, 08	1/2 Year
5.	Bilog Antenna	Schaffner	CBL6111C	2598	Nov.10, 08	1 Year
6.	RF Cable	JINGCHENG	JB Y400	3# Chamber No.1	Nov.01, 08	1/2 Year
7.	RF Cable	JINGCHENG	JB Y400	3# Chamber No.2	Nov.01, 08	1/2 Year
8.	RF Cable	JINGCHENG	JB Y400	3# Chamber No.3	Nov.01, 08	1/2 Year
9.	RF Cable	JINGCHENG	JB Y400	3# Chamber No.4	Nov.01, 08	1/2 Year
10.	Coaxial Switch	Anritsu	MP59B	M73989	Nov.01, 08	1/2 Year

Frequency rang: above 1000MHz

Item	Equipment	Manufacturer	Model No.	Serial No.	Last Cal.	Cal. Interval
1.	Spectrum Analyzer	Agilent	E4446A	US44300459	May.10, 08	1 Year
2.	Horn Antenna	EMCO	3115	9607-4877	May.27, 08	1.5 Year
3.	Horn Antenna	EMCO	3116	00060088	May.27, 08	1Year
4.	Amplifier	Agilent	8449B	3008A02495	Nov.24,08	1 Year
5.	RF Cable	Hubersuhner	SUCOFLEX102	28620/2	May.28, 08	1 Year
6.	RF Cable	Hubersuhner	SUCOFLEX102	271471/4	May.28, 08	1 Year
7.	RF Cable	Hubersuhner	SUCOFLEX102	29086/2	May.28, 08	1 Year

4.2. Block Diagram of Test Setup

4.2.1. Block Diagram of connection between EUT and simulators

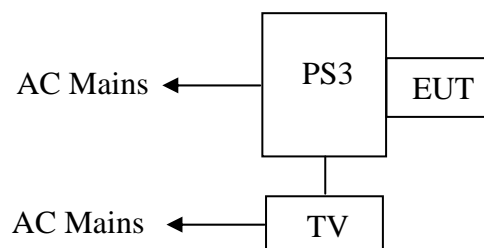

(EUT: PS3 Wireless American P-Bass guitar controller)

4.2.2.Anechoic Chamber Setup Diagram

ANTENNA TOWER

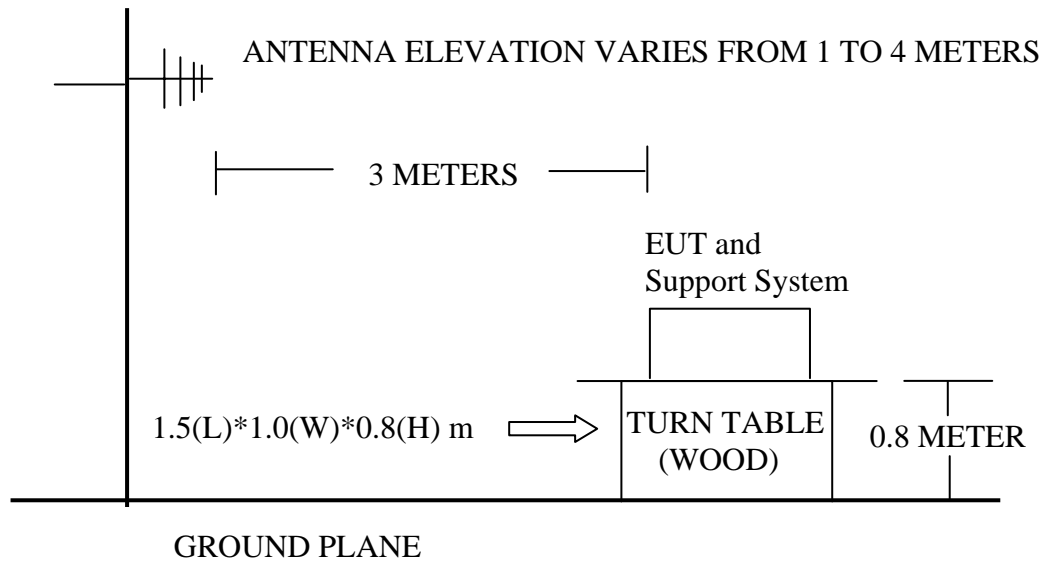

4.3. Radiated Emission Limit Standard: FCC 15.209 and 15.249

FREQUENCY MHz	DISTANCE Meters	FIELD STRENGTHS LIMIT	
		μV/m	dB(μV)/m
30 ~ 88	3	100	40.0
88 ~ 216	3	150	43.5
216 ~ 960	3	200	46.0
960 ~ 1000	3	500	54.0
Above 960MHz	3	74.0 dB(μV)/m (Peak) 54.0 dB(μV)/m (Average)	
Field Strength of Fundamental emission for 2.4GHz-2.4835GHz	3	94.0 dB(μV)/m (Average) 114.0 dB(μV)/m(Peak)	
Field Strength of Harmonics	3	74.0 dB(μV)/m (Peak) 54.0 dB(μV)/m (Average)	

- Remark :
- (1) Emission level $\text{dB}\mu\text{V} = 20 \log \text{Emission level } \mu\text{V}/\text{m}$
 - (2) The smaller limit shall apply at the cross point between two frequency bands.
 - (3) Distance is the distance in meters between the measuring instrument, antenna and the closest point of any part of the device or system.
 - (4) The emission limits shown in the above table are based on measurements employing a CISPR quasi-peak detector except for the frequency bands 9-90 kHz, 110-490 kHz and above 1000 MHz. Radiated emission limits in these three bands are based on measurements employing an average detector.

4.4. EUT Configuration on Test

The following equipment are installed on Radiated Emission Test to meet the commission requirements and operating regulations in a manner which tends to maximize its emission characteristics in normal application.

4.4.1. PS3 Wireless American P-Bass guitar controller (EUT)

Model Number : 9766

Serial Number : N/A

4.4.2. Support Equipment: As Tested Supporting System Detail, in Section 2.2..

4.5. Operating Condition of EUT

4.5.1. Setup the EUT as shown in Section 4.2..

4.5.2. Let the EUT worked in test mode (Tx Mode) and tested it.

4.6. Test Procedure

The EUT and its simulators are placed on a turn table, which is 0.8 meter high above ground. The turn table can rotate 360 degrees to determine the position of the maximum emission level. The EUT is set 3 meters away from the receiving antenna, which is mounted on a antenna tower. The antenna can be moved up and down between 1 meter and 4 meters to find out the maximum emission level. Broadband antenna (calibrated bilog antenna) is used as receiving antenna. Both horizontal and vertical polarization of the antenna is set on Test. In order to find the maximum emission levels, all of the interface cables must be manipulated according to ANSI C63.4-2003 on radiated emission Test.

The bandwidth of the EMI test receiver (R&S ESVS10) is set at 120kHz for frequency range from 30MHz to 1000 MHz.

The bandwidth of the VBW is set at 1MHz and RBW is set at 1MHz, PK detector for peak emissions measurement above 1GHz.

The duty cycle factor was use to calculate Average Level above 1 GHz.

The frequency range from 30MHz to 10th harmonic (25GHz) are checked and no any emissions were found from 18GHz to 25 GHz, So the radiated emissions from 18GHz to 25GHz were not record.

4.7. Radiated Emission Test Results

PASS.

All the emissions from 30MHz to 25GHz were comply with the 15.209 and 15.249 Limit.

Duty factor = $20 \log(1/x) = 29.61$
 $X = T_x \text{ on} / (T_x \text{ on} + T_x \text{ off}) = 0.033$

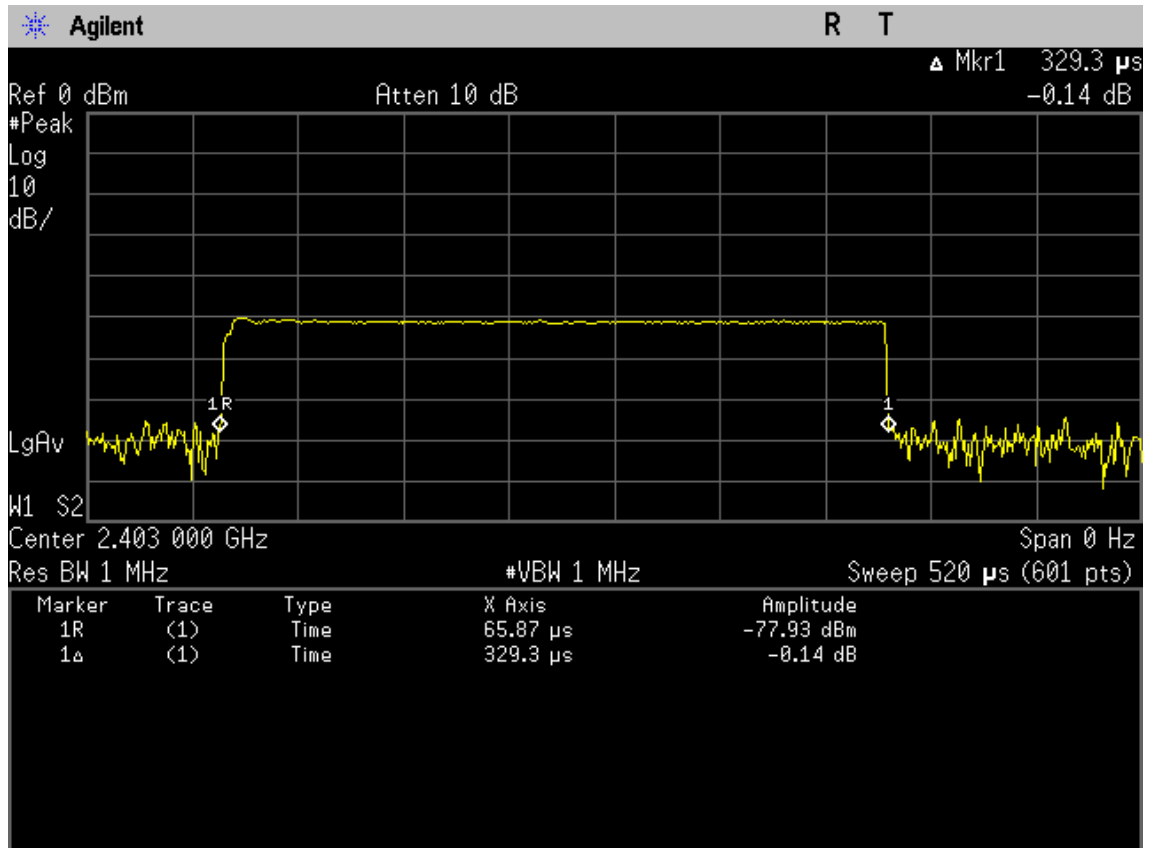
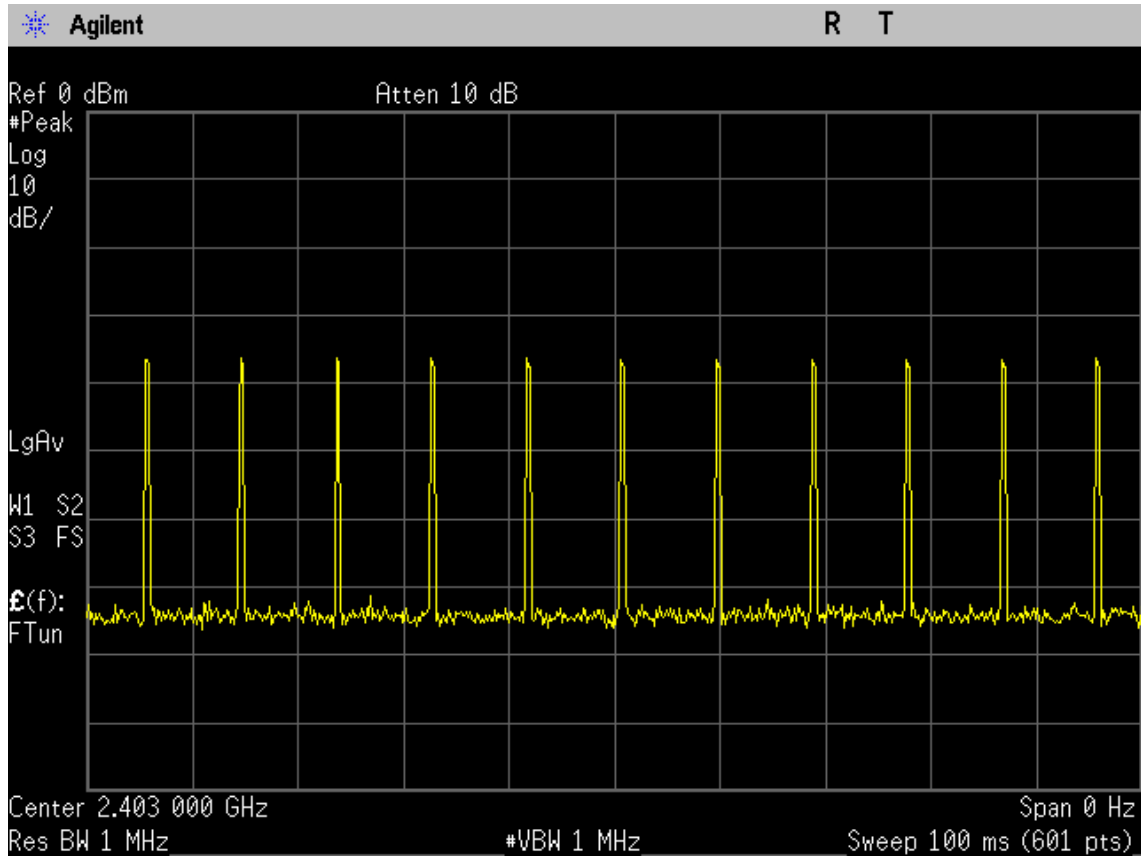

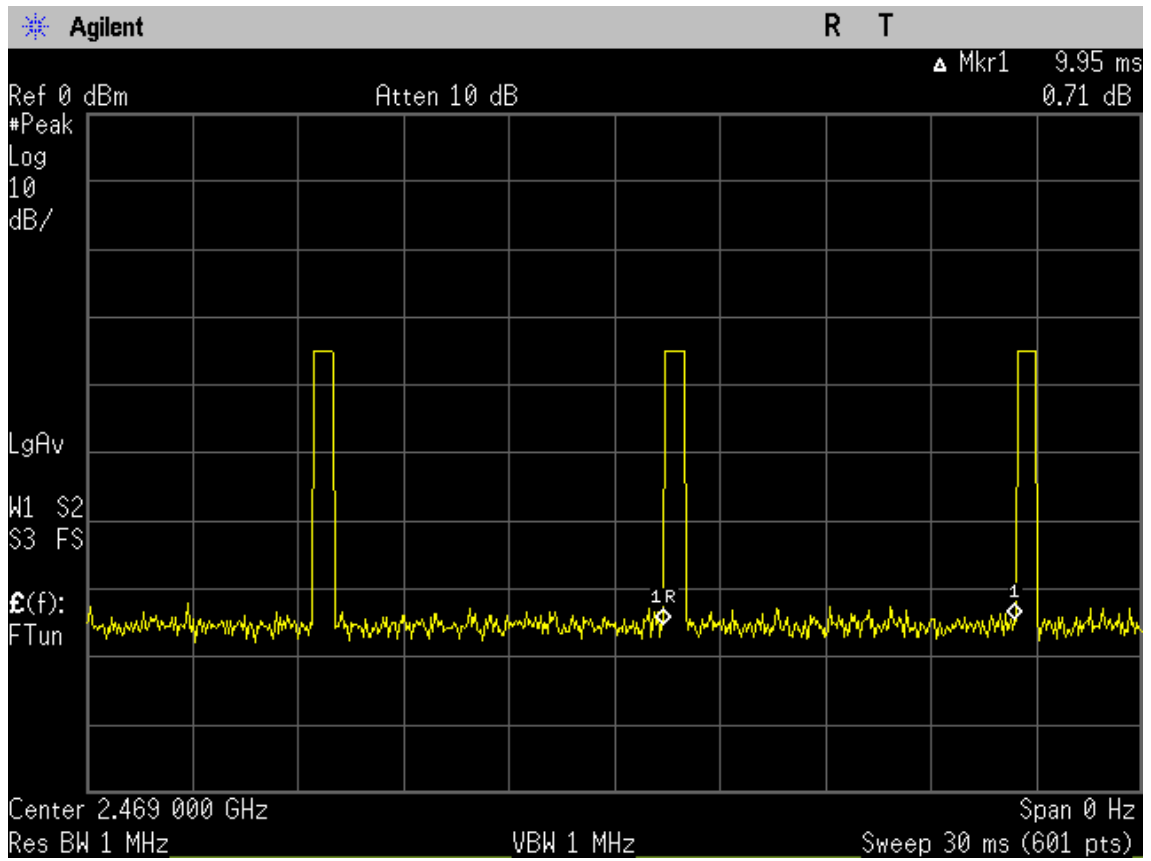

Test Frequency: 30MHz-1000MHz



No.6,Ke Feng Road,Block 52,
Shenzhen Science&Industry Park
Nantou Shenzhen,Guangdong,China
Tel:+86-755-26639495
Fax:+86-755-26632877
Postcode:518057

Data: 4 File: D:\2009 Report Data\MMAD CATZ\ACS9QH026.EM6 (4) Date: 2009-02-24

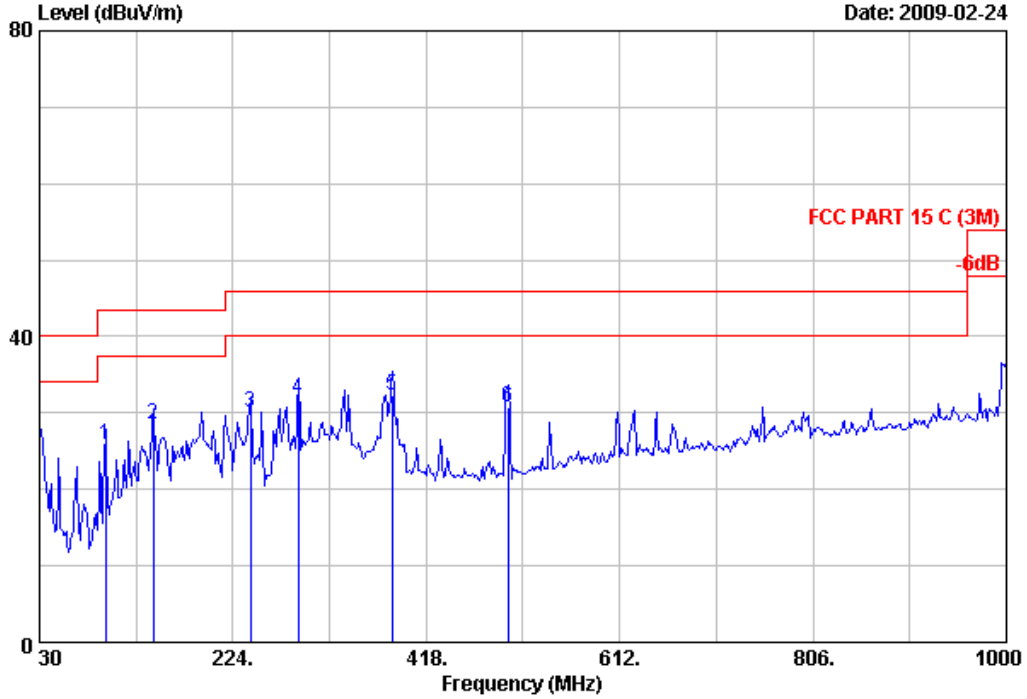

Site no. : 3m Chamber Data no. : 4
Dis. / Ant. : 3m CBL6111C Ant. pol. : HORIZONTAL
Limit : FCC PART 15 C (3M)
Env. / Ins. : 24°C/47% Engineer : Power
EUT : PS3 Wireless American P-Bass guitar controller
Power Rating : DC 5V from PS3 input AC120V/60Hz
Test Mode : Running
M/N : 9766 (Dongle)

	Freq. (MHz)	Ant. Factor (dB/m)	Cable Loss (dB)	Reading (dBuV)	Emission Level (dBuV/m)	Limits (dBuV/m)	Margin (dB)	Remark
1	95.960	9.74	0.91	15.18	25.83	43.50	17.67	QP
2	144.460	11.78	1.15	15.68	28.61	43.50	14.89	QP
3	241.460	11.80	1.57	16.82	30.19	46.00	15.81	QP
4	289.960	13.43	1.79	16.57	31.79	46.00	14.21	QP
5	384.050	15.72	2.14	14.49	32.35	46.00	13.65	QP
6	500.450	18.04	2.52	10.16	30.72	46.00	15.28	QP

Remarks: 1. Emission Level= Antenna Factor + Cable Loss + Reading.
2. The emission levels that are 20dB below the official limit are not reported.



No.6,Ke Feng Road,Block 52,
Shenzhen Science&Industry Park
Nantou Shenzhen,Guangdong,China
Tel:+86-755-26639495
Fax:+86-755-26632877
Postcode:518057

Data: 3 File: D:\2009 Report Data\MMAD CATZ\ACS9QH026.EM6 (4)

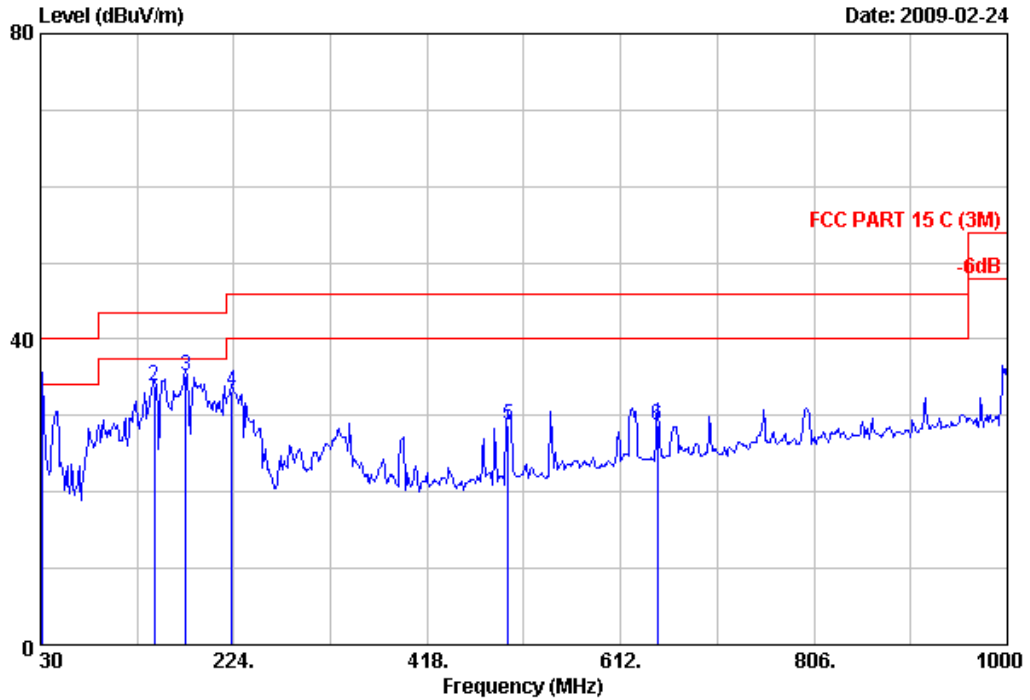

Site no. : 3m Chamber Data no. : 3
 Dis. / Ant. : 3m CBL6111C Ant. pol. : VERTICAL
 Limit : FCC PART 15 C (3M)
 Env. / Ins. : 24°C/47% Engineer : Power
 EUT : PS3 Wireless American P-Bass guitar controller
 Power Rating : DC 5V from PS3 input AC120V/60Hz
 Test Mode : Running
 M/N : 9766 (Dongle)

	Freq. (MHz)	Ant. Factor (dB/m)	Cable Loss (dB)	Reading (dBuV)	Emission Level (dBuV/m)	Limits (dBuV/m)	Margin (dB)	Remark
1	31.940	18.73	0.49	13.85	33.07	40.00	6.93	QP
2	144.460	11.78	1.15	20.90	33.83	43.50	9.67	QP
3	175.500	9.64	1.28	24.22	35.14	43.50	8.36	QP
4	222.060	10.26	1.49	21.35	33.10	46.00	12.90	QP
5	499.480	18.02	2.51	8.29	28.82	46.00	17.18	QP
6	648.860	19.98	3.11	5.57	28.66	46.00	17.34	QP

Remarks: 1. Emission Level= Antenna Factor + Cable Loss + Reading.
 2. The emission levels that are 20dB below the official limit are not reported.

Test Frequency: 1GHz-18GHz



No.6 Ke Feng Road,Block 52,
ShenZhen Science & Industry Park
Noutou,ShenZhen,GuangDong,China
Tel:+86-755-26639495-7
Fax:+86-755-26632877
Postcode:518057

Data: 23 File: E:\2009 report data\M\Mad Catz\ACS90H026.EM6 (36)

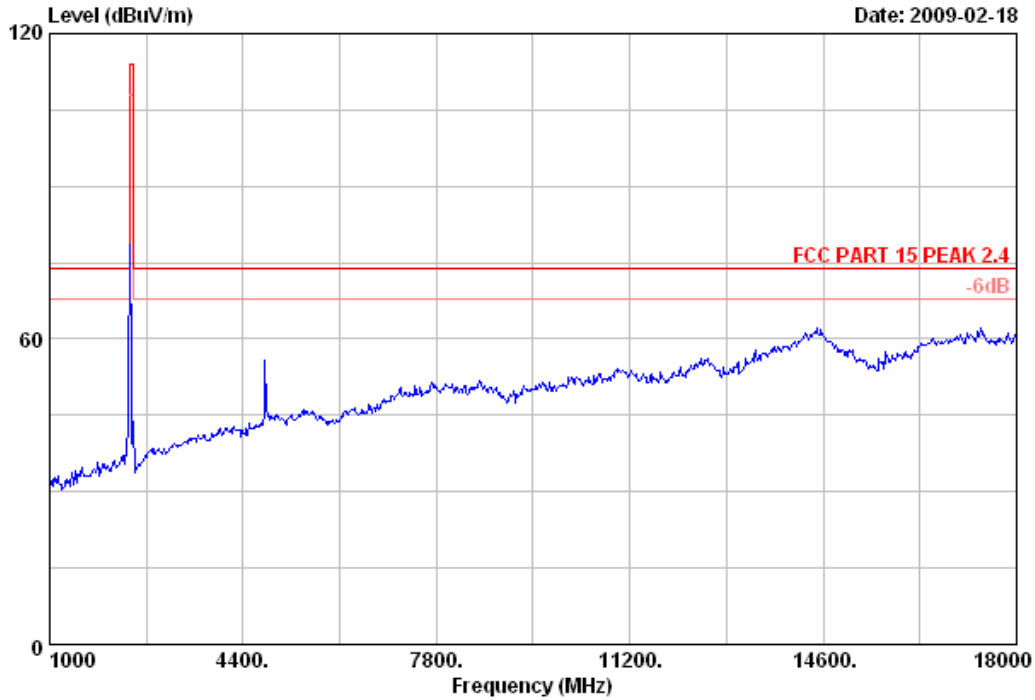

Site no.	: 3# Chamber	Data no.	: 23
Dis. / Ant.	: 3m 3115	Ant. pol.	: HORIZONTAL
Limit	: FCC PART 15 PEAK 2.4		
Env. / Ins.	: 23°C/54%	Engineer	: Alan
EUT	: PS3 Wireless American P-Bass giutar controller		
Power Rating	: DC 5V from PS3 input AC 120V/60Hz		
Test mode	: TX 2403MHz		
M/N	: 9766 (Dongle)		



No.6 Ke Feng Road,Block 52,
ShenZhen Science & Industry Park
Noutou,ShenZhen,GuangDong,China
Tel:+86-755-26639495-7
Fax:+86-755-26632877
Postcode:518057

Data: 24 File: E:\2009 report data\M\Mad Catz\ACS9QH026.EM6 (36)

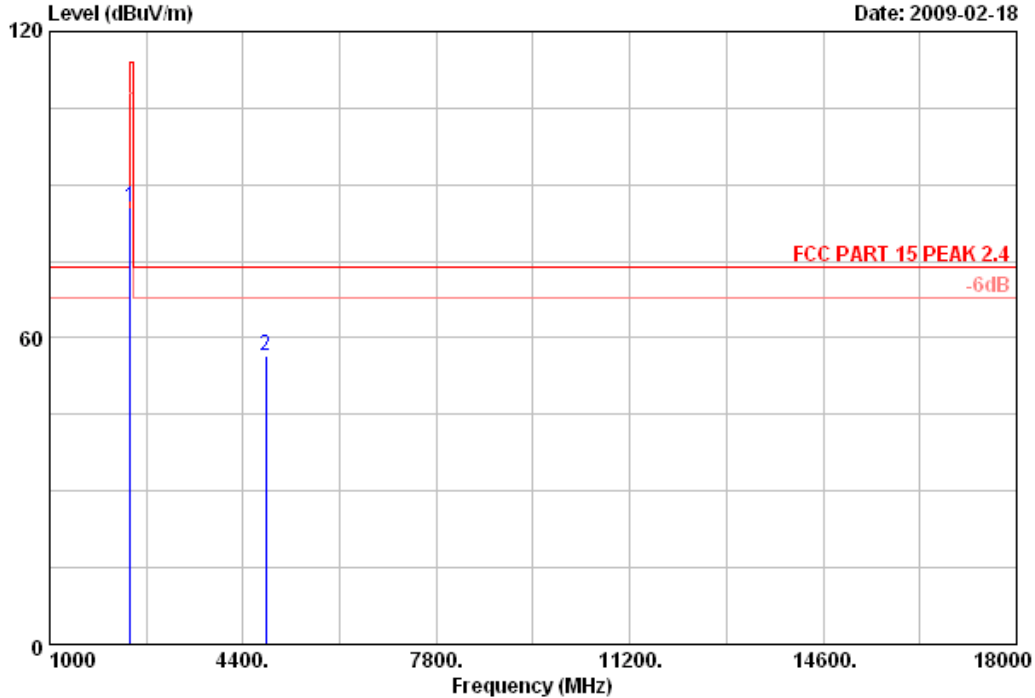

Site no. : 3# Chamber Data no. : 24
 Dis. / Ant. : 3m 3115 Ant. pol. : HORIZONTAL
 Limit : FCC PART 15 PEAK 2.4
 Env. / Ins. : 23*C/54% Engineer : Alan
 EUT : PS3 Wireless American P-Bass giutar controller
 Power Rating : DC 5V from PS3 input AC 120V/60Hz
 Test mode : TX 2403MHz
 M/N : 9766 (Dongle)

	Freq.	Ant.	Cable	Amp	Emission				Remark
	(MHz)	Factor	Loss	Factor	Reading	Level	Limits	Margin	
		(dB/m)	(dB)	(dB)	(dBuV)	(dBuV/m)	(dBuV/m)	(dB)	
1	2403.000	28.48	6.73	35.12	85.54	85.63	114.00	28.37	Peak
2	4806.000	34.36	10.54	34.60	46.25	56.55	74.00	17.45	Peak

Remarks:

- Emission Level= Antenna Factor + Cable Loss -Amp Factor + Reading.
- The emission levels that are 20dB below the official limit are not reported.

Frequency (MHz)	PK Level (dBuV/m)	Duty cycle factor (dB)	Average Level (dBuV/m)	Limit (dBuV/m)	Margin (dB)
2403	85.63	29.61	56.02	94	37.98
4806	56.55	29.61	26.94	54	27.06



No.6 Ke Feng Road,Block 52,
ShenZhen Science & Industry Park
Noutou,ShenZhen,GuangDong,China
Tel:+86-755-26639495-7
Fax:+86-755-26632877
Postcode:518057

Data: 21 File: E:\2009 report data\M\Mad Catz\ACS9QH026.EM6 (36)

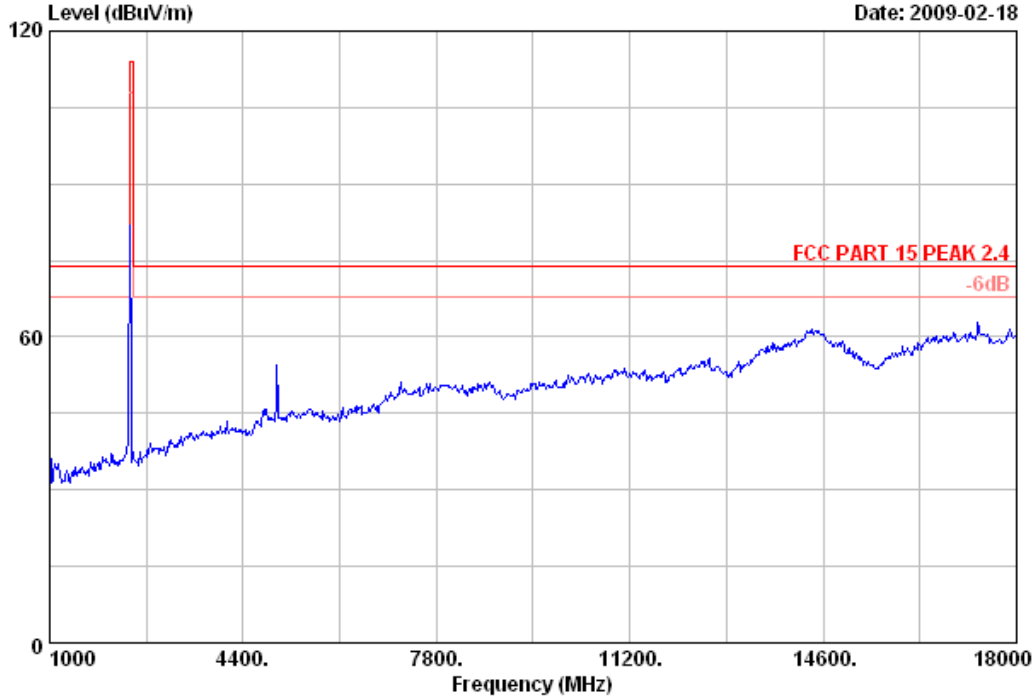

Site no. : 3# Chamber Data no. : 21
Dis. / Ant. : 3m 3115 Ant. pol. : VERTICAL
Limit : FCC PART 15 PEAK 2.4
Env. / Ins. : 23*C/54% Engineer : Alan
EUT : PS3 Wireless American P-Bass giutar controller
Power Rating : DC 5V from PS3 input AC 120V/60Hz
Test mode : TX 2403MHz
M/N : 9766 (Dongle)



No.6 Ke Feng Road,Block 52,
ShenZhen Science & Industry Park
Noutou, ShenZhen, GuangDong, China
Tel:+86-755-26639495-7
Fax:+86-755-26632877
Postcode:518057

Data: 22 File: E:\2009 report data\MMad Catz\ACS9QH026.EM6 (36) Date: 2009-02-18

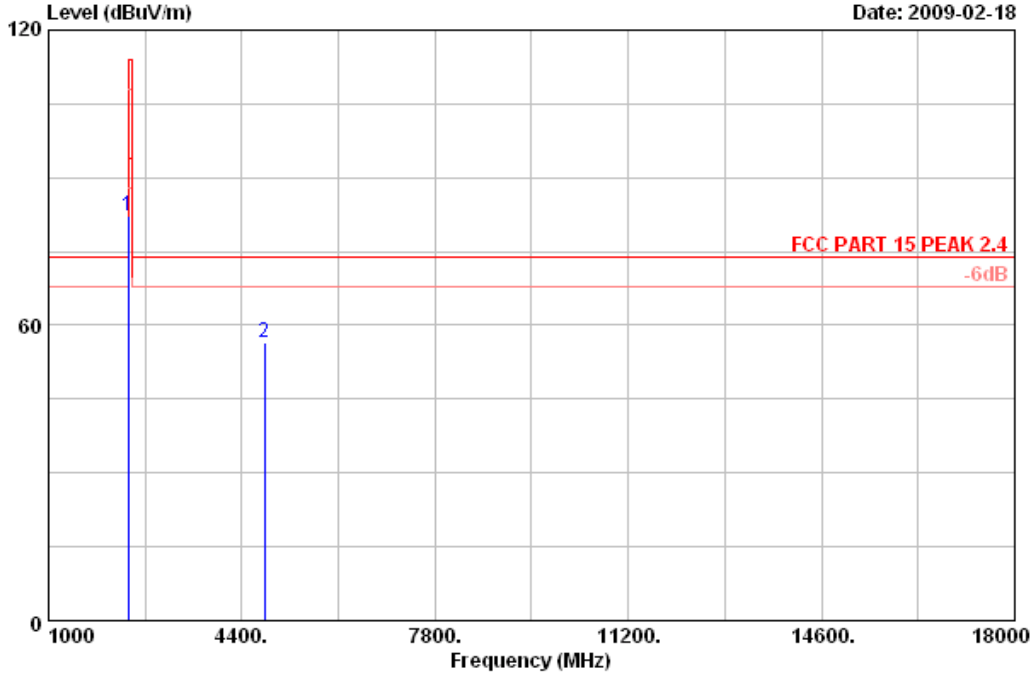

Site no. : 3# Chamber Data no. : 22
 Dis. / Ant. : 3m 3115 Ant. pol. : VERTICAL
 Limit : FCC PART 15 PEAK 2.4
 Env. / Ins. : 23°C/54% Engineer : Alan
 EUT : PS3 Wireless American P-Bass guitar controller
 Power Rating : DC 5V from PS3 input AC 120V/60Hz
 Test mode : TX 2403MHz
 M/N : 9766 (Dongle)

	Ant.	Cable	Amp	Emission					
Freq.	Factor	Loss	Factor	Reading	Level	Limits	Margin	Remark	
(MHz)	(dB/m)	(dB)	(dB)	(dBuV)	(dBuV/m)	(dBuV/m)	(dB)		
1 2403.000	28.48	6.73	35.12	82.25	82.34	114.00	31.66	Peak	
2 4806.000	34.36	10.54	34.60	46.70	57.00	74.00	17.00	Peak	

Remarks:
 1. Emission Level= Antenna Factor + Cable Loss -Amp Factor + Reading.
 2. The emission levels that are 20dB below the official limit are not reported.

Frequency (MHz)	PK Level (dBuV/m)	Duty cycle factor (dB)	Average Level (dBuV/m)	Limit (dBuV/m)	Margin (dB)
2403	82.34	29.61	52.73	94	41.27
4806	57.00	29.61	27..39	54	26.61



No.6 Ke Feng Road,Block 52,
ShenZhen Science & Industry Park
Noutou, ShenZhen, GuangDong, China
Tel:+86-755-26639495-7
Fax:+86-755-26632877
Postcode:518057

Data: 25 File: E:\2009 report data\M\Mad Catz\ACS9QH026.EM6 (36)

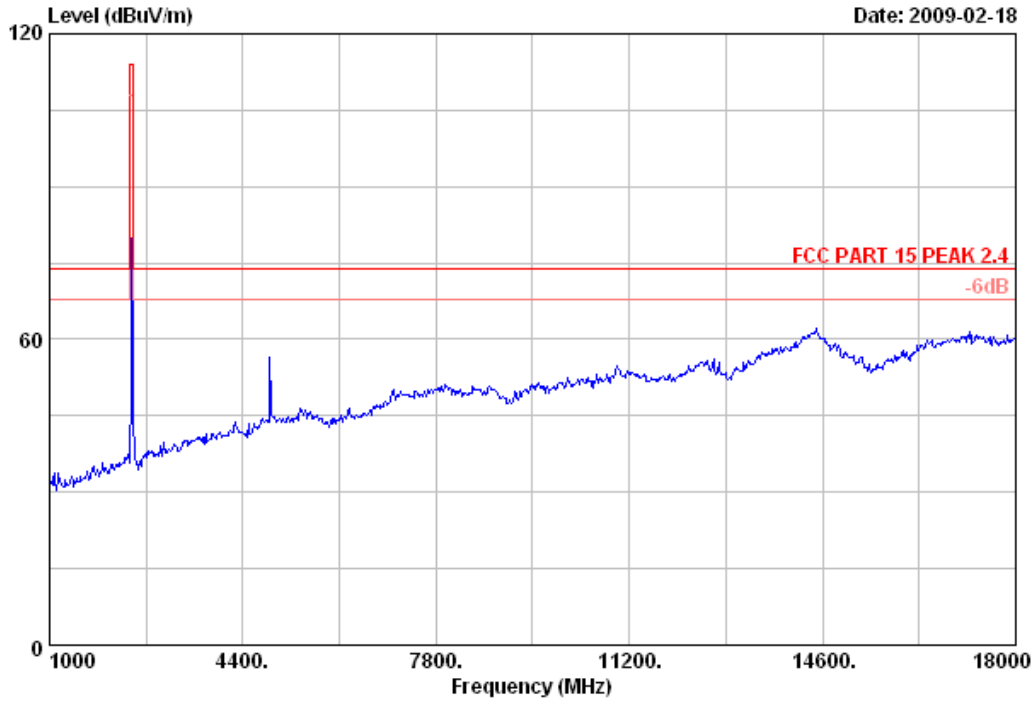

Site no. : 3# Chamber Data no. : 25
Dis. / Ant. : 3m 3115 Ant. pol. : HORIZONTAL
Limit : FCC PART 15 PEAK 2.4
Env. / Ins. : 23*C/54% Engineer : Alan
EUT : PS3 Wireless American P-Bass giutar controller
Power Rating : DC 5V from PS3 input AC 120V/60Hz
Test mode : TX 2441MHz
M/N : 9766 (Dongle)



No.6 Ke Feng Road,Block 52,
Shenzhen Science & Industry Park
Noutou,Shenzhen,GuangDong,China
Tel:+86-755-26639495-7
Fax:+86-755-26632877
Postcode:518057

Data: 26 File: E:\2009 report data\M\Mad Catz\ACS90H026.EM6 (36) Date: 2009-02-18

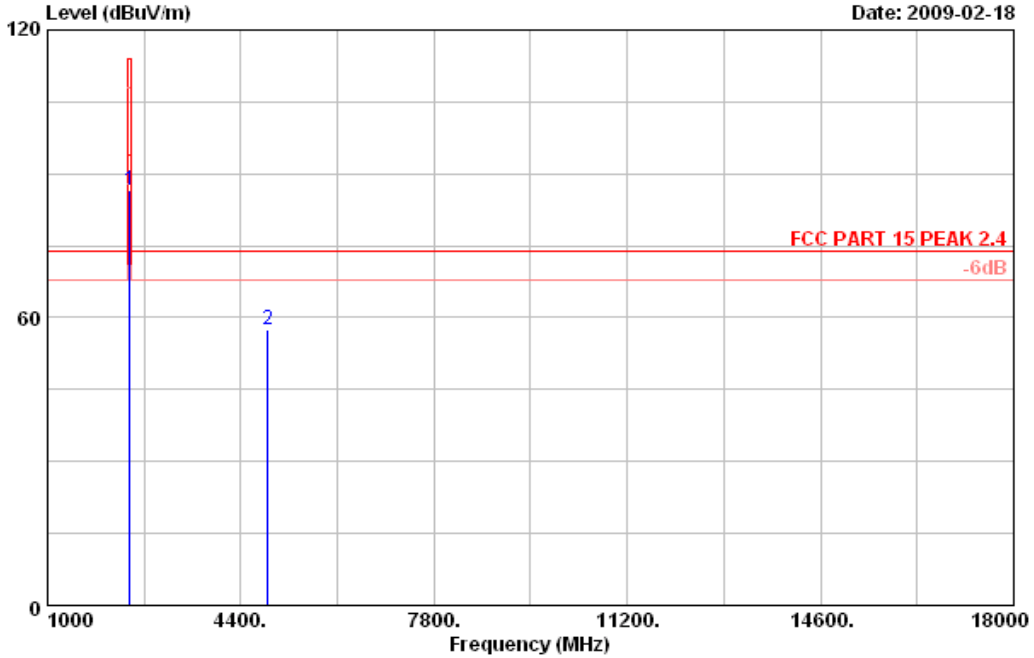

Site no. : 3# Chamber Data no. : 26
 Dis. / Ant. : 3m 3115 Ant. pol. : HORIZONTAL
 Limit : FCC PART 15 PEAK 2.4
 Env. / Ins. : 23*C/54% Engineer : Alan
 EUT : PS3 Wireless American P-Bass giutar controller
 Power Rating : DC 5V from PS3 input AC 120V/60Hz
 Test mode : TX 2441MHz
 M/N : 9766 (Dongle)

	Freq. (MHz)	Ant. Factor (dB/m)	Cable Loss (dB)	Amp Factor (dB)	Reading (dBuV)	Emission Level (dBuV/m)	Limits (dBuV/m)	Margin (dB)	Remark
1	2441.000	28.53	6.80	35.11	86.19	86.41	114.00	27.59	Peak
2	4882.000	34.78	10.57	34.58	46.80	57.57	74.00	16.43	Peak

- Remarks:
1. Emission Level= Antenna Factor + Cable Loss -Amp Factor + Reading.
 2. The emission levels that are 20dB below the official limit are not reported.

Frequency (MHz)	PK Level (dBuV/m)	Duty cycle factor (dB)	Average Level (dBuV/m)	Limit (dBuV/m)	Margin (dB)
2441	86.41	29.61	56.80	94	37.20
4882	57.57	29.61	27.96	54	26.04



No.6 Ke Feng Road,Block 52,
ShenZhen Science & Industry Park
Noutou, ShenZhen, GuangDong, China
Tel:+86-755-26639495-7
Fax:+86-755-26632877
Postcode:518057

Data: 27 File: E:\2009 report data\MMad Catz\ACS9QH026.EM6 (36)

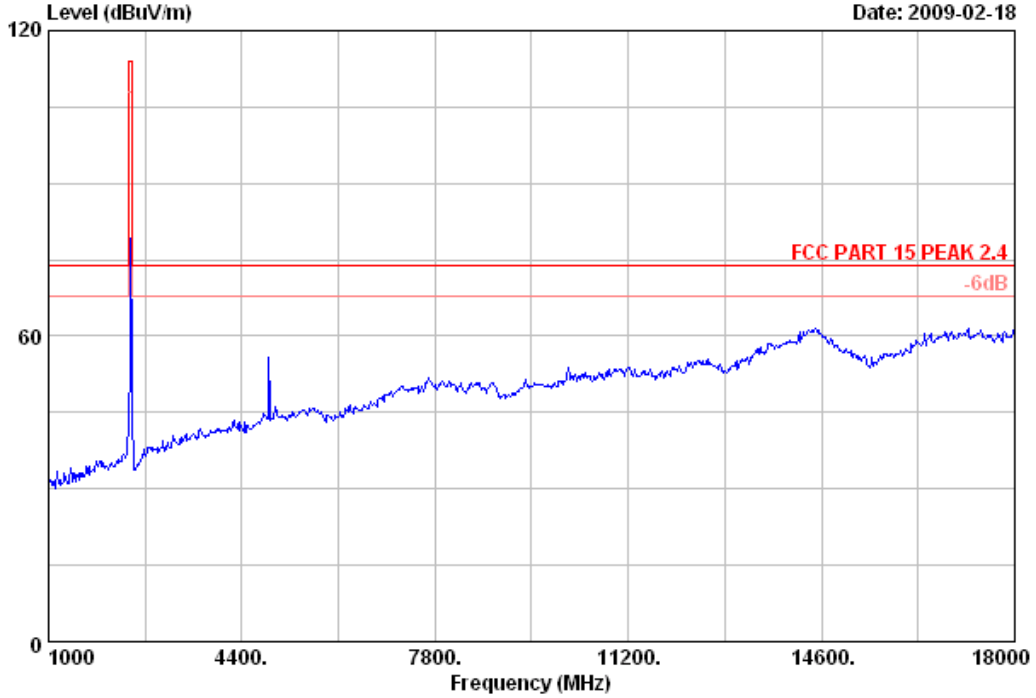

Site no. : 3# Chamber Data no. : 27
Dis. / Ant. : 3m 3115 Ant. pol. : VERTICAL
Limit : FCC PART 15 PEAK 2.4
Env. / Ins. : 23*C/54% Engineer : Alan
EUT : PS3 Wireless American P-Bass giutar controller
Power Rating : DC 5V from PS3 input AC 120V/60Hz
Test mode : TX 2441MHz
M/N : 9766 (Dongle)



No.6 Ke Feng Road,Block 52,
ShenZhen Science & Industry Park
Noutou, ShenZhen, GuangDong, China
Tel:+86-755-26639495-7
Fax:+86-755-26632877
Postcode:518057

Data: 28 File: E:\2009 report data\MMad Catz\ACS9QH026.EM6 (36)

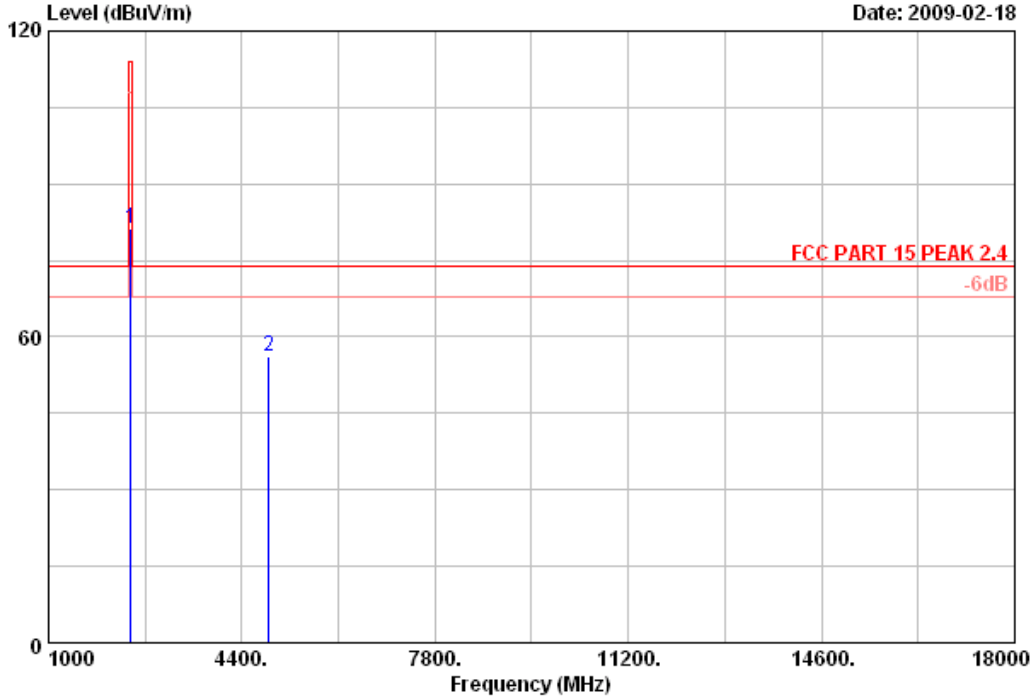

Site no. : 3# Chamber Data no. : 28
 Dis. / Ant. : 3m 3115 Ant. pol. : VERTICAL
 Limit : FCC PART 15 PEAK 2.4
 Env. / Ins. : 23*C/54% Engineer : Alan
 EUT : PS3 Wireless American P-Bass giutar controller
 Power Rating : DC 5V from PS3 input AC 120V/60Hz
 Test mode : TX 2441MHz
 M/N : 9766 (Dongle)

	Freq. (MHz)	Ant. Factor (dB/m)	Cable Loss (dB)	Amp Factor (dB)	Reading (dBuV)	Emission Level (dBuV/m)	Limits (dBuV/m)	Margin (dB)	Remark
1	2441.000	28.53	6.80	35.11	81.07	81.29	114.00	32.71	Peak
2	4882.000	34.78	10.57	34.58	45.36	56.13	74.00	17.87	Peak

Remarks:

- Emission Level= Antenna Factor + Cable Loss -Amp Factor + Reading.
- The emission levels that are 20dB below the official limit are not reported.

Frequency (MHz)	PK Level (dBuV/m)	Duty cycle factor (dB)	Average Level (dBuV/m)	Limit (dBuV/m)	Margin (dB)
2441	81.29	29.61	51.68	94	42.32
4882	56.13	29.61	26.52	54	27.48



No.6 Ke Feng Road,Block 52,
ShenZhen Science & Industry Park
Noutou, ShenZhen, GuangDong, China
Tel:+86-755-26639495-7
Fax:+86-755-26632877
Postcode:518057

Data: 17 File: E:\2009 report data\MMad Catz\ACS9QH026.EM6 (36)

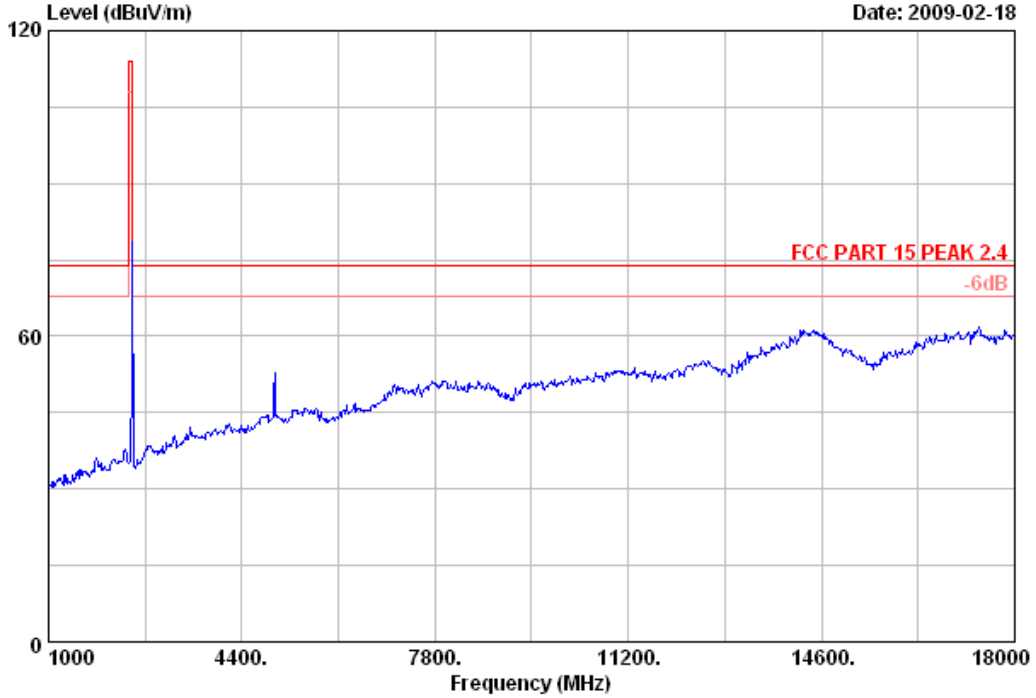

Site no. : 3# Chamber Data no. : 17
Dis. / Ant. : 3m 3115 Ant. pol. : HORIZONTAL
Limit : FCC PART 15 PEAK 2.4
Env. / Ins. : 23*C/54% Engineer : Alan
EUT : PS3 Wireless American P-Bass giutar controller
Power Rating : DC 5V from PS3 input AC 120V/60Hz
Test mode : TX 2480MHz
M/N : 9766 (Dongle)



No.6 Ke Feng Road,Block 52,
ShenZhen Science & Industry Park
Noutou, ShenZhen, GuangDong, China
Tel:+86-755-26639495-7
Fax:+86-755-26632877
Postcode:518057

Data: 18 File: E:\2009 report data\M\Mad Catz\ACS9QH026.EM6 (36)

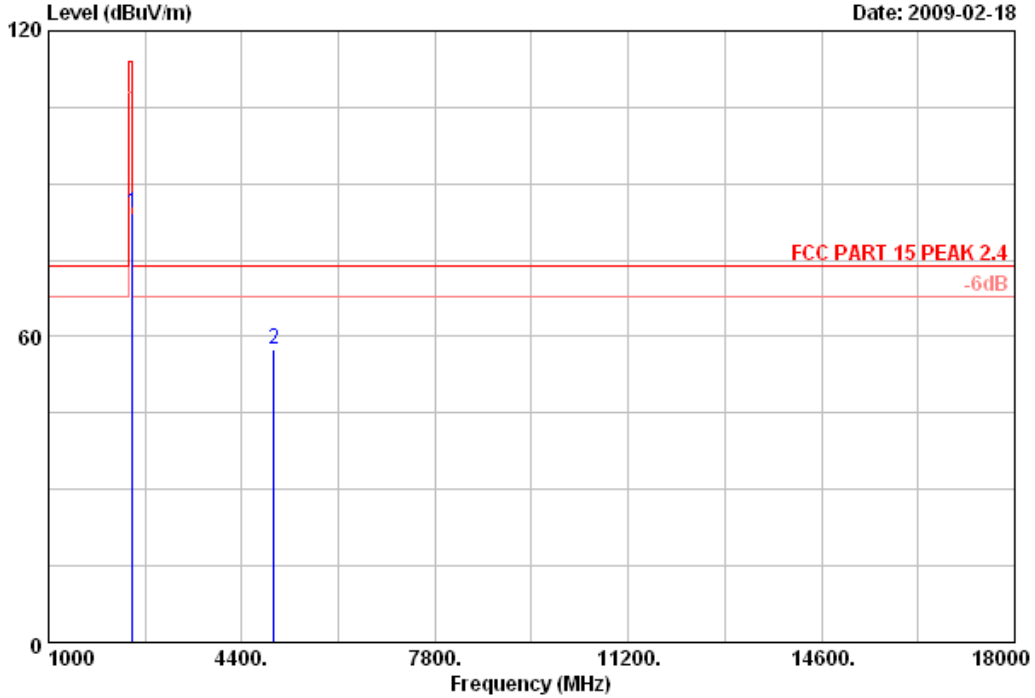

Site no. : 3# Chamber Data no. : 18
 Dis. / Ant. : 3m 3115 Ant. pol. : HORIZONTAL
 Limit : FCC PART 15 PEAK 2.4
 Env. / Ins. : 23*C/54% Engineer : Alan
 EUT : PS3 Wireless American P-Bass giutar controller
 Power Rating : DC 5V from PS3 input AC 120V/60Hz
 Test mode : TX 2480MHz
 M/N : 9766 (Dongle)

	Freq.	Ant. Factor	Cable Loss	Amp Factor	Emission Reading	Emission Level	Limits	Margin	Remark
	(MHz)	(dB/m)	(dB)	(dB)	(dBuV)	(dBuV/m)	(dBuV/m)	(dB)	
1	2480.000	28.58	6.87	35.10	83.90	84.25	114.00	29.75	Peak
2	4960.000	35.29	10.59	34.56	46.22	57.54	74.00	16.46	Peak

Remarks:

- Emission Level= Antenna Factor + Cable Loss -Amp Factor + Reading.
- The emission levels that are 20dB below the official limit are not reported.

Frequency (MHz)	PK Level (dBuV/m)	Duty cycle factor (dB)	Average Level (dBuV/m)	Limit (dBuV/m)	Margin (dB)
2480	84.25	29.61	54.64	94	39.36
4960	57.54	29.61	27.93	54	26.07



No.6 Ke Feng Road,Block 52,
ShenZhen Science & Industry Park
Noutou, ShenZhen, GuangDong, China
Tel:+86-755-26639495-7
Fax:+86-755-26632877
Postcode:518057

Data: 19 File: E:\2009 report data\MMad Catz\ACS9QH026.EM6 (36)

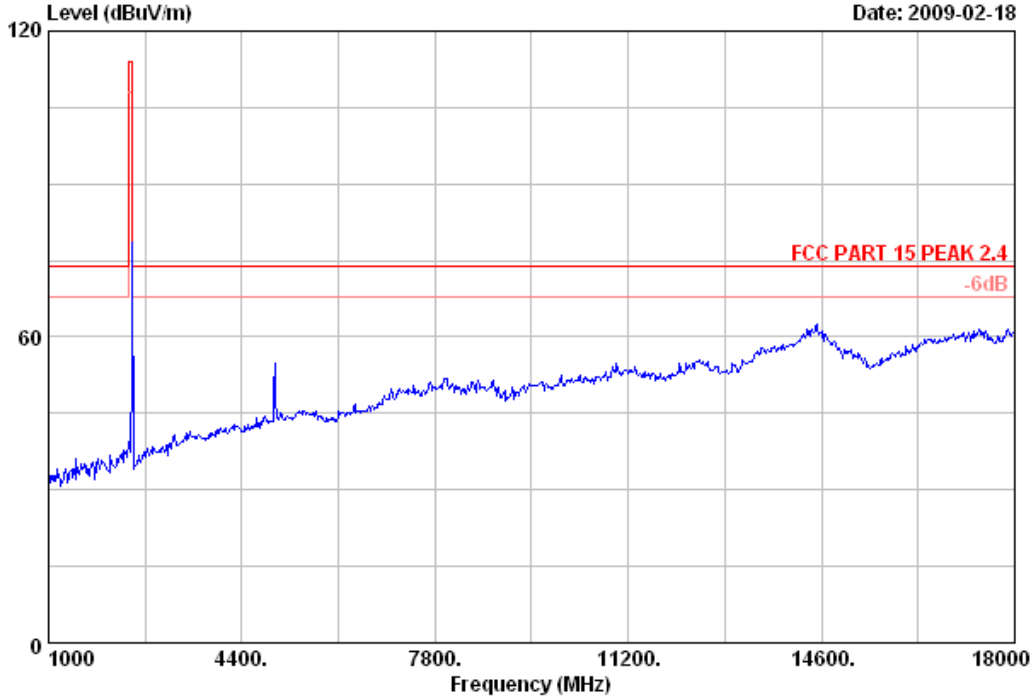

Site no.	: 3# Chamber	Data no.	: 19
Dis. / Ant.	: 3m 3115	Ant. pol.	: VERTICAL
Limit	: FCC PART 15 PEAK 2.4		
Env. / Ins.	: 23°C/54%	Engineer	: Alan
EUT	: PS3 Wireless American P-Bass giutar controller		
Power Rating	: DC 5V from PS3 input AC 120V/60Hz		
Test mode	: TX 2480MHz		
M/N	: 9766 (Dongle)		



No.6 Ke Feng Road,Block 52,
ShenZhen Science & Industry Park
Noutou, ShenZhen, GuangDong, China
Tel:+86-755-26639495-7
Fax:+86-755-26632877
Postcode:518057

Data: 20 File: E:\2009 report data\M\Mad Catz\ACS9QH026.EM6 (36)

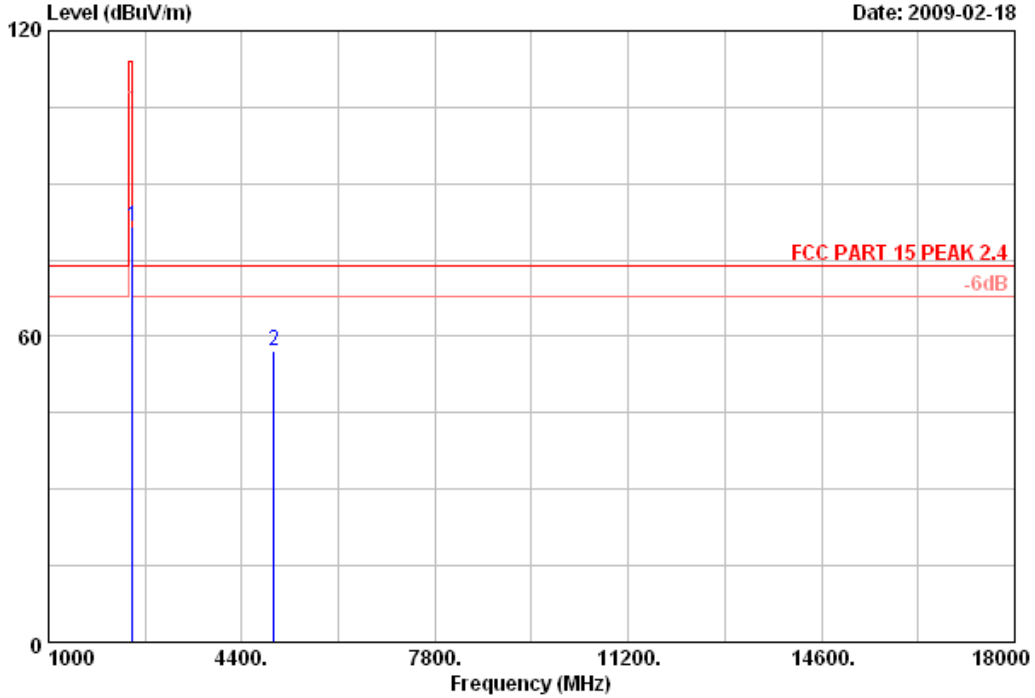

Site no. : 3# Chamber Data no. : 20
 Dis. / Ant. : 3m 3115 Ant. pol. : VERTICAL
 Limit : FCC PART 15 PEAK 2.4
 Env. / Ins. : 23*C/54% Engineer : Alan
 EUT : PS3 Wireless American P-Bass giutar controller
 Power Rating : DC 5V from PS3 input AC 120V/60Hz
 Test mode : TX 2480MHz
 M/N : 9766 (Dongle)

	Ant.	Cable	Amp	Emission					
Freq.	Factor	Loss	Factor	Reading	Level	Limits	Margin	Remark	
(MHz)	(dB/m)	(dB)	(dB)	(dBuV)	(dBuV/m)	(dBuV/m)	(dB)		
1 2480.000	28.58	6.87	35.10	81.22	81.57	114.00	32.43	Peak	
2 4960.000	35.29	10.59	34.56	45.85	57.17	74.00	16.83	Peak	

Remarks:

- Emission Level= Antenna Factor + Cable Loss -Amp Factor + Reading.
- The emission levels that are 20dB below the official limit are not reported.

Frequency (MHz)	PK Level (dBuV/m)	Duty cycle factor (dB)	Average Level (dBuV/m)	Limit (dBuV/m)	Margin (dB)
2480	81.57	29.61	51.96	94	42.04
4960	57.17	29.61	27.56	54	26.44

5. BAND EDGE COMPLIANCE TEST

5.1. Test Equipment

Item	Equipment	Manufacturer	Model No.	Serial No.	Last Cal.	Cal. Interval
1	Spectrum Analyzer	Agilent	E4446A	US44300459	May,10, 08	1 Year
2	Horn Antenna	EMCO	3115	9607-4877	May, 27, 08	1.5 Year
3	Amplifier	Agilent	8449B	3008A02495	Nov 6.08	1 Year
4	RF Cable	Hubersuhner	SUCOFLEX 102	28620/2	May,28, 08	1 Year
5	RF Cable	Hubersuhner	SUCOFLEX 102	271471/4	May,28, 08	1 Year
6	RF Cable	Hubersuhner	SUCOFLEX 102	29086/2	May,28, 08	1 Year

5.2. Limit

Emissions radiated outside of the specified frequency bands, except for harmonics, shall be attenuated by at least 50dB below the level of the fundamental or to the general radiated emission limits in section 15.209, which is the lesser attenuation.

5.3. Test Produce

1. The EUT is placed on a turntable, which is 0.8m above the ground plane and worked at highest radiated power.
2. The turntable was rotated for 360 degrees to determine the position of maximum emission level.
3. EUT is set 3m away from the receiving antenna, which is varied from 1m to 4m to find out the highest emission.
4. Set the spectrum analyzer in the following setting in order to capture the lower and upperband-edges of the emission:
 - (a) PEAK: RBW=VBW=1MHz, PK detector, Sweep=AUTO

5.4. Test Results

Pass (The testing data was attached in the next pages.)



No.6 Ke Feng Road,Block 52,
 ShenZhen Science & Industry Park
 Noutou,ShenZhen,GuangDong,China
 Tel:+86-755-26639495-7
 Fax:+86-755-26632877
 Postcode:518057

Data: 30 File: E:\2009 report data\M\Mad Catz\ACS9QH026.EM6 (36)

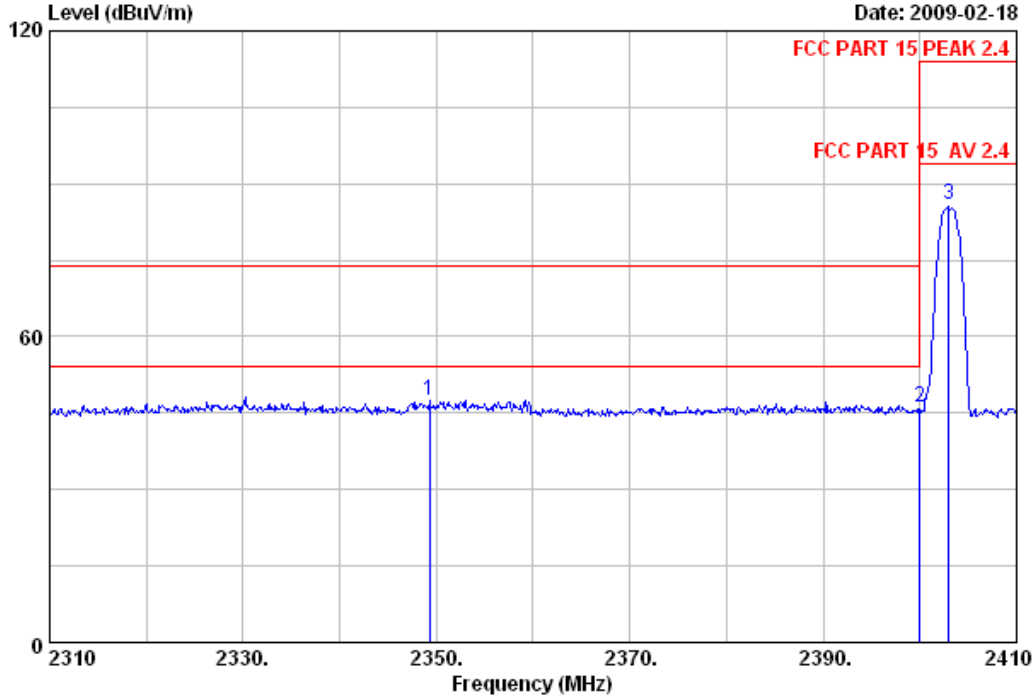

Site no. : 3# Chamber Data no. : 30
 Dis. / Ant. : 3m 3115 Ant. pol. : HORIZONTAL
 Limit : FCC PART 15 PEAK 2.4
 Env. / Ins. : 23°C/54% Engineer : Alan
 EUT : PS3 Wireless American P-Bass guitar controller
 Power Rating : DC 5V from PS3 input AC 120V/60Hz
 Test mode : TX 2403MHz
 M/N : 9766 (Dongle)

	Freq. (MHz)	Ant. Factor (dB/m)	Cable Loss (dB)	Amp Factor (dB)	Reading Level (dBuV)	Emission Level (dBuV/m)	Limits (dBuV/m)	Margin (dB)	Remark
1	2349.300	28.38	6.67	35.13	47.41	47.33	74.00	26.67	Peak
2	2400.000	28.46	6.73	35.12	46.09	46.16	74.00	27.84	Peak
3	2403.000	28.48	6.73	35.12	85.71	85.80	114.00	28.20	Peak

Remarks:

1. Emission Level= Antenna Factor + Cable Loss -Amp Factor + Reading.
2. The emission levels that are 20dB below the official limit are not reported.

Note: All the PK levels fall in the restricted bands comply with Average limit, so the average levels are deemed to comply with average limit.



No.6 Ke Feng Road,Block 52,
 ShenZhen Science & Industry Park
 Noutou, ShenZhen, GuangDong, China
 Tel:+86-755-26639495-7
 Fax:+86-755-26632877
 Postcode:518057

Data: 29 File: E:\2009 report data\M\Mad Catz\ACS9QH026.EM6 (36)

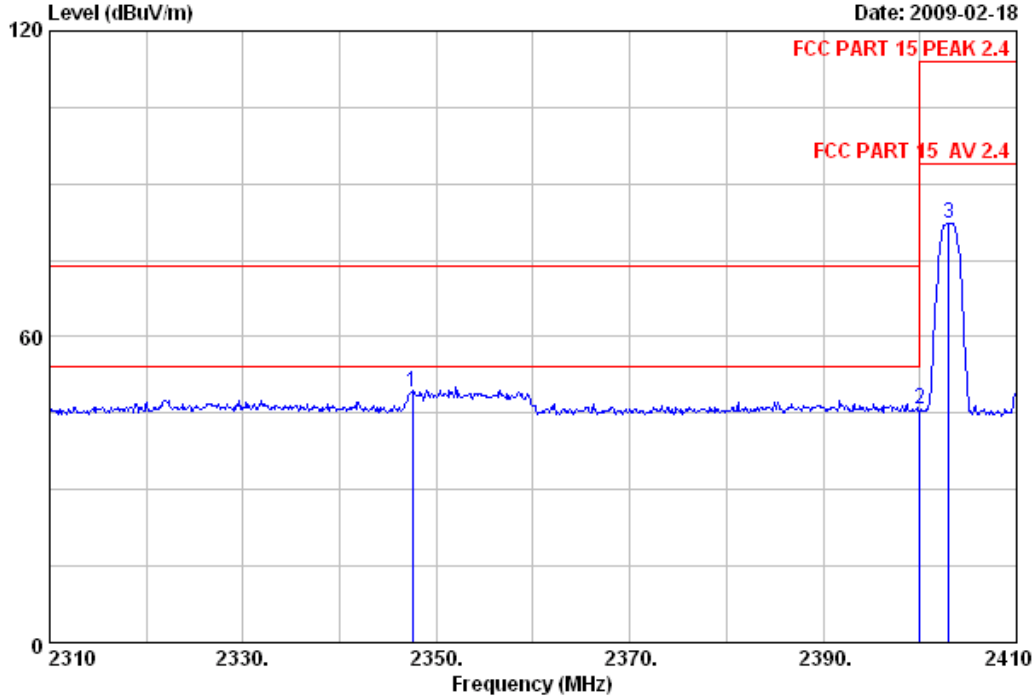

Site no. : 3# Chamber Data no. : 29
 Dis. / Ant. : 3m 3115 Ant. pol. : VERTICAL
 Limit : FCC PART 15 PEAK 2.4
 Env. / Ins. : 23*C/54% Engineer : Alan
 EUT : PS3 Wireless American P-Bass giutar controller
 Power Rating : DC 5V from PS3 input AC 120V/60Hz
 Test mode : TX 2403MHz
 M/N : 9766 (Dongle)

	Freq. (MHz)	Ant. Factor (dB/m)	Cable Loss (dB)	Amp Factor (dB)	Emission				Remark
					Reading (dBuV)	Level (dBuV/m)	Limits (dBuV/m)	Margin (dB)	
1	2347.500	28.38	6.67	35.13	49.08	49.00	74.00	25.00	Peak
2	2400.000	28.46	6.73	35.12	45.84	45.91	74.00	28.09	Peak
3	2403.000	28.48	6.73	35.12	82.20	82.29	114.00	31.71	Peak

Remarks:

1. Emission Level= Antenna Factor + Cable Loss -Amp Factor + Reading.
2. The emission levels that are 20dB below the official limit are not reported.

Note: All the PK levels fall in the restricted bands comply with Average limit, so the average levels are deemed to comply with average limit.



No.6 Ke Feng Road,Block 52,
 ShenZhen Science & Industry Park
 Noutou,ShenZhen,GuangDong,China
 Tel:+86-755-26639495-7
 Fax:+86-755-26632877
 Postcode:518057

Data: 31 File: E:\2009 report data\M\Mad Catz\ACS9QH026.EM6 (36)

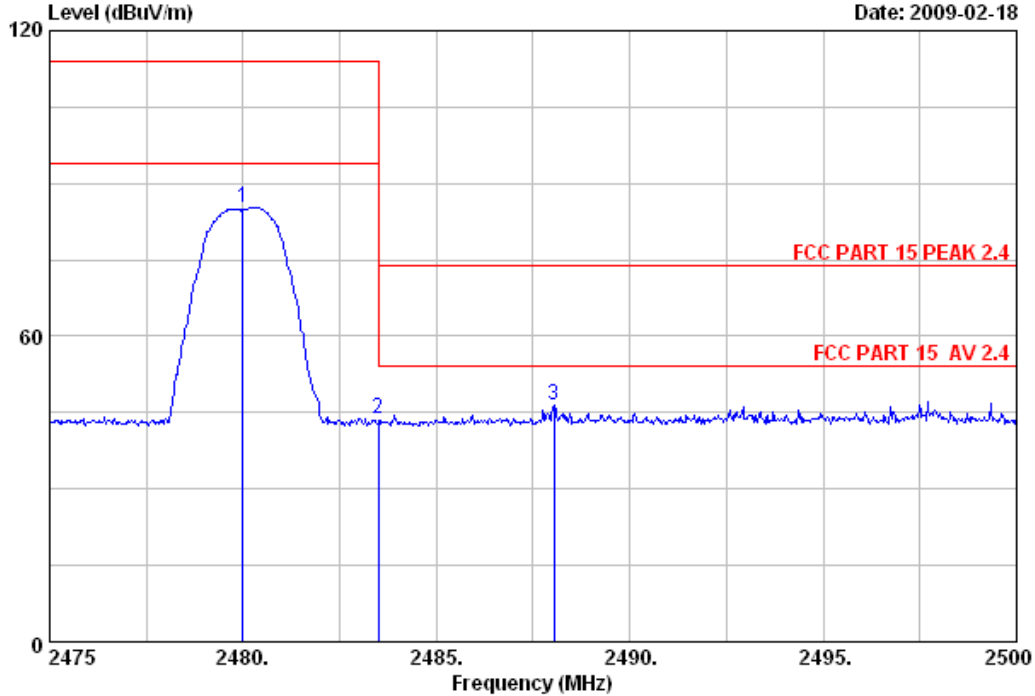

Site no. : 3# Chamber Data no. : 31
 Dis. / Ant. : 3m 3115 Ant. pol. : HORIZONTAL
 Limit : FCC PART 15 PEAK 2.4
 Env. / Ins. : 23°C/54% Engineer : Alan
 EUT : PS3 Wireless American P-Bass guitar controller
 Power Rating : DC 5V from PS3 input AC 120V/60Hz
 Test mode : TX 2480MHz
 M/N : 9766 (Dongle)

	Freq. (MHz)	Ant. Factor (dB/m)	Cable Loss (dB)	Amp Factor (dB)	Emission		Limits (dBuV/m)	Margin (dB)	Remark
					Reading (dBuV)	Level (dBuV/m)			
1	2480.000	28.58	6.87	35.10	84.96	85.31	114.00	28.69	Peak
2	2483.500	28.58	6.87	35.10	43.55	43.90	74.00	30.10	Peak
3	2488.050	28.60	6.87	35.10	46.06	46.43	74.00	27.57	Peak

Remarks:

- Emission Level= Antenna Factor + Cable Loss -Amp Factor + Reading.
- The emission levels that are 20dB below the official limit are not reported.

Note: All the PK levels fall in the restricted bands comply with Average limit, so the average levels are deemed to comply with average limit.



No.6 Ke Feng Road,Block 52,
 ShenZhen Science & Industry Park
 Noutou,ShenZhen,GuangDong,China
 Tel:+86-755-26639495-7
 Fax:+86-755-26632877
 Postcode:518057

Data: 32 File: E:\2009 report data\M\Mad Catz\ACS9QH026.EM6 (36)

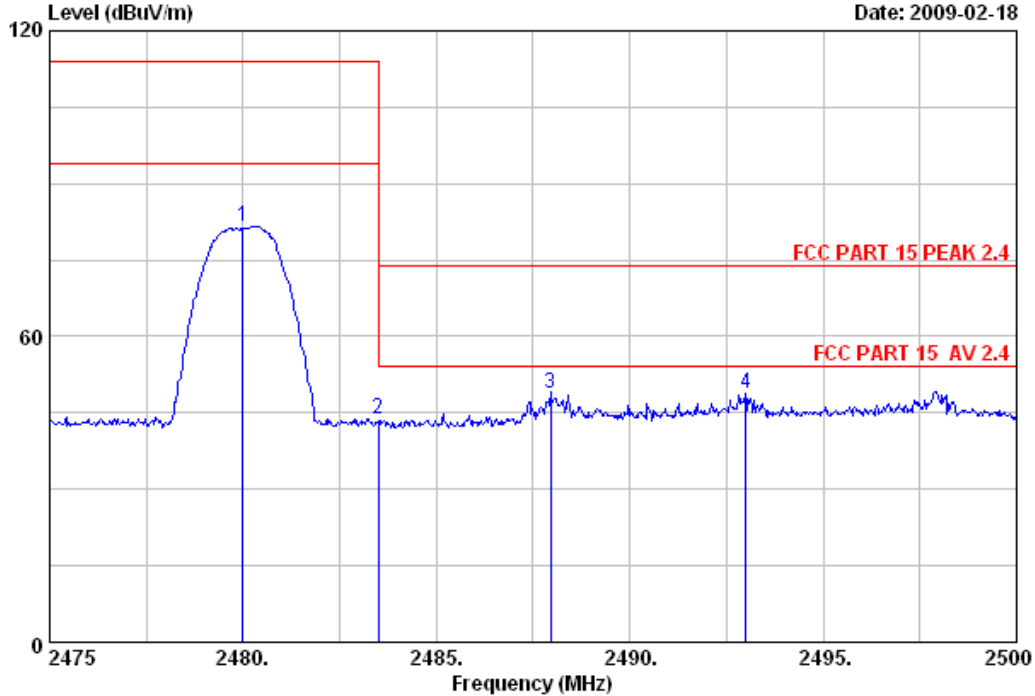

Site no. : 3# Chamber Data no. : 32
 Dis. / Ant. : 3m 3115 Ant. pol. : VERTICAL
 Limit : FCC PART 15 PEAK 2.4
 Env. / Ins. : 23°C/54% Engineer : Alan
 EUT : PS3 Wireless American P-Bass guitar controller
 Power Rating : DC 5V from PS3 input AC 120V/60Hz
 Test mode : TX 2480MHz
 M/N : 9766 (Dongle)

	Freq.	Ant.	Cable	Amp	Emission		Limits	Margin	Remark
	(MHz)	(dB/m)	(dB)	(dB)	Reading	Level	(dBuV/m)	(dB)	
					(dBuV)	(dBuV/m)			
1	2480.000	28.58	6.87	35.10	81.18	81.53	114.00	32.47	Peak
2	2483.500	28.58	6.87	35.10	43.60	43.95	74.00	30.05	Peak
3	2487.950	28.60	6.87	35.10	48.55	48.92	74.00	25.08	Peak
4	2493.000	28.60	6.91	35.10	48.35	48.76	74.00	25.24	Peak

- Remarks:
- Emission Level= Antenna Factor + Cable Loss -Amp Factor + Reading.
 - The emission levels that are 20dB below the official limit are not reported.

Note: All the PK levels fall in the restricted bands comply with Average limit, so the average levels are deemed to comply with average limit.

6. 20DB BANDWIDTH TEST

6.1. Test Equipment

Item	Equipment	Manufacturer	Model No.	Serial No.	Last Cal.	Cal. Interval
1	Spectrum Analyzer	Agilent	E4446A	US44300459	May,10, 08	1 Year
2	Attenuator	Agilent	8491B	MY39262165	May,28, 08	1 Year
3	RF Cable	Hubersuhner	SUCOFLEX 102	28618/2	May,28, 08	1Year

6.2. Limit

Intentional radiators operating under the alternative provisions to the general emission limits, as contained in §§ 15.217 through 15.257 and in Subpart E of this part, must be designed to ensure that the 20 dB bandwidth of the emission, or whatever bandwidth may otherwise be specified in the specific rule section under which the equipment operates, is contained within the frequency band designated in the rule section under which the equipment is operated.

6.3. Test Results

CH	20dB Bandwidth (kHz)	Limit (kHz)	Conclusion
(Low)	1250	---	PASS
(Mid)	1033	---	PASS
(High)	908	---	PASS

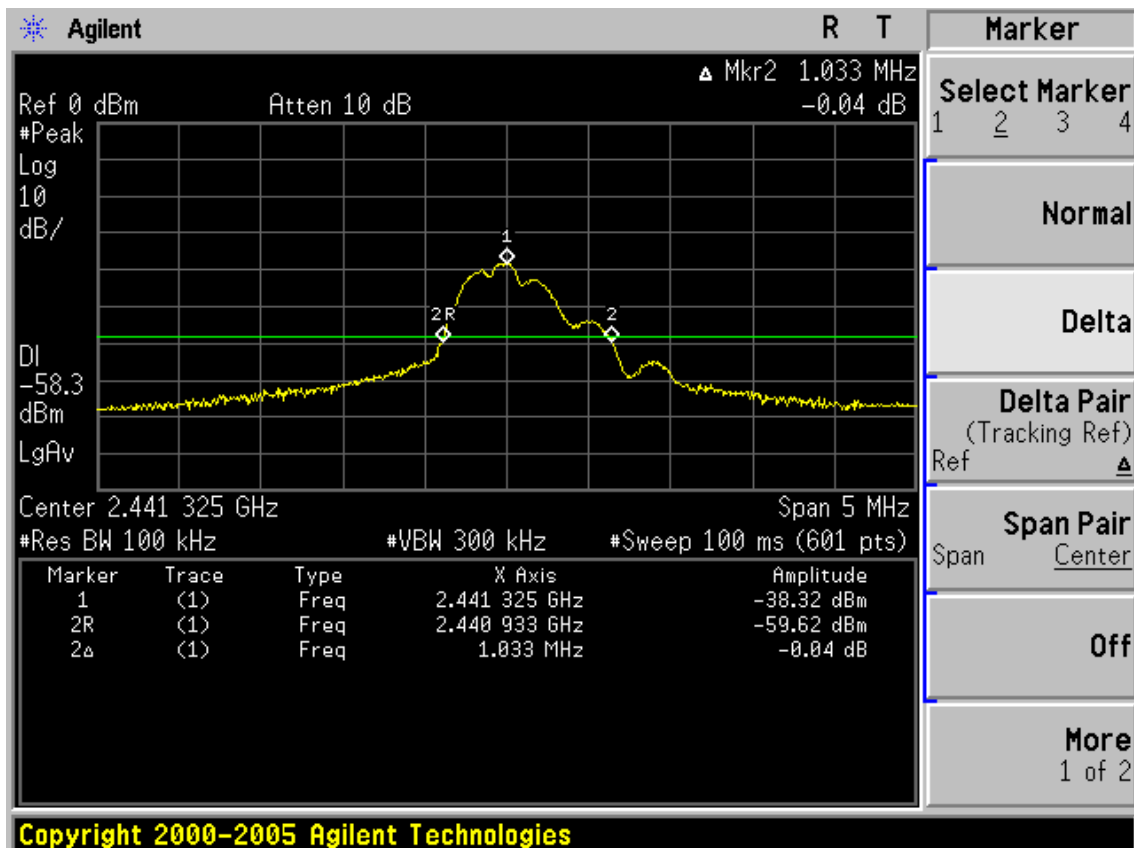
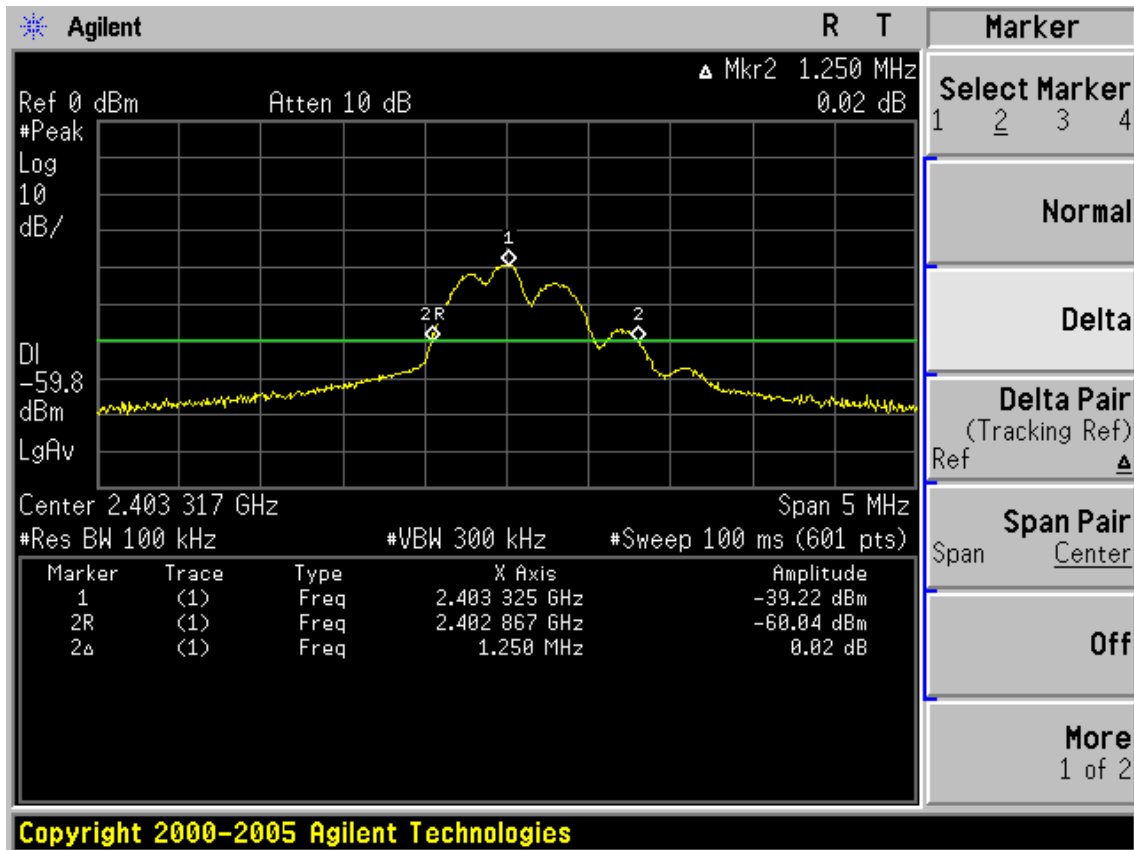

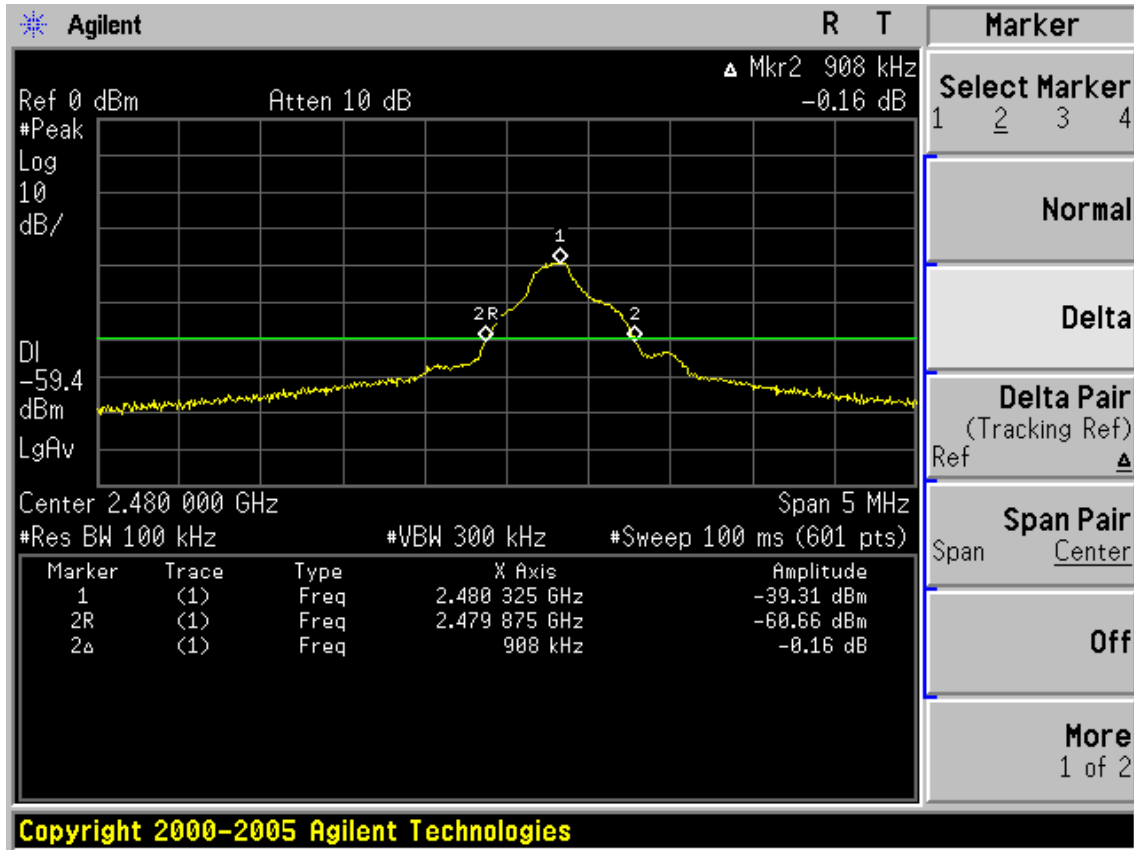

7. DEVIATION TO TEST SPECIFICATIONS

[NONE]

8. PHOTOGRAPH OF TEST

8.1. Photos of Power Line Conducted Emission Test



8.2. Photos of Radiated Emission Test (In Anechoic Chamber)

30~1000MHz

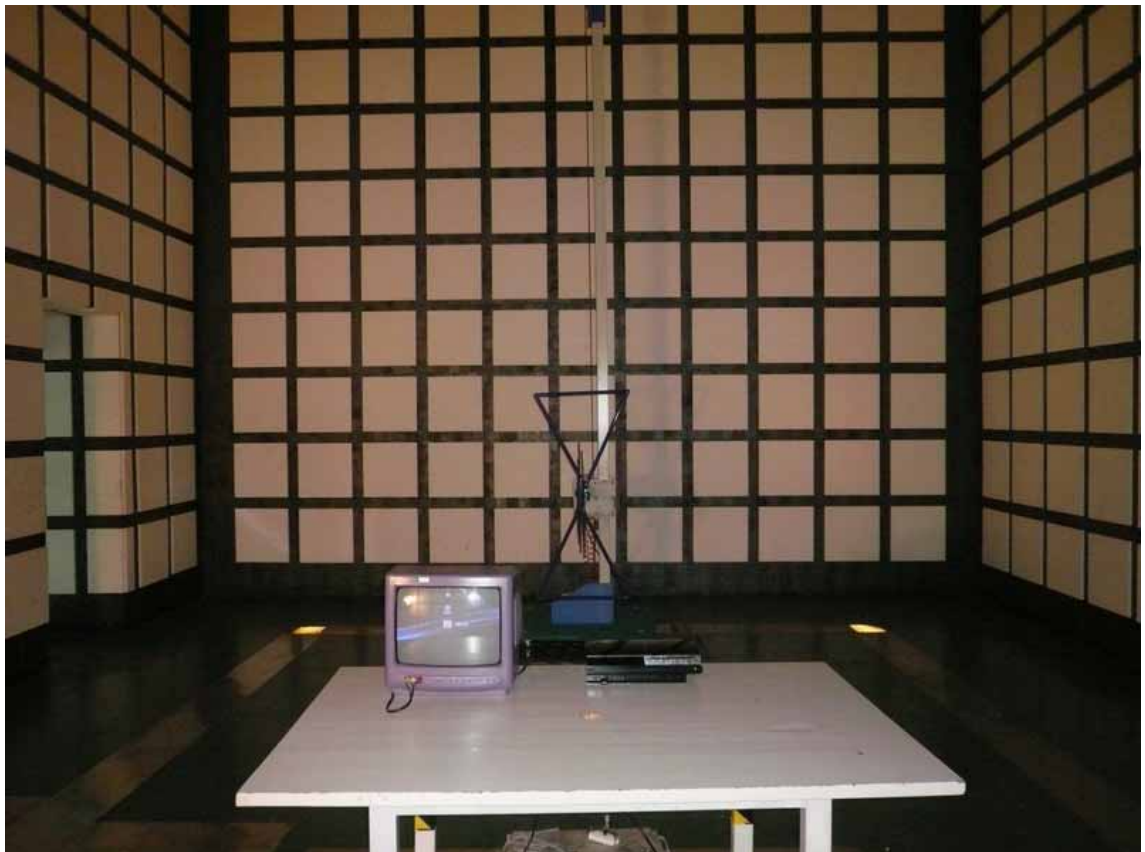

above 1000MHz



9. PHOTOGRAPH OF EUT

Figure 1
General Appearance of the EUT



Figure 2
General Appearance of the EUT

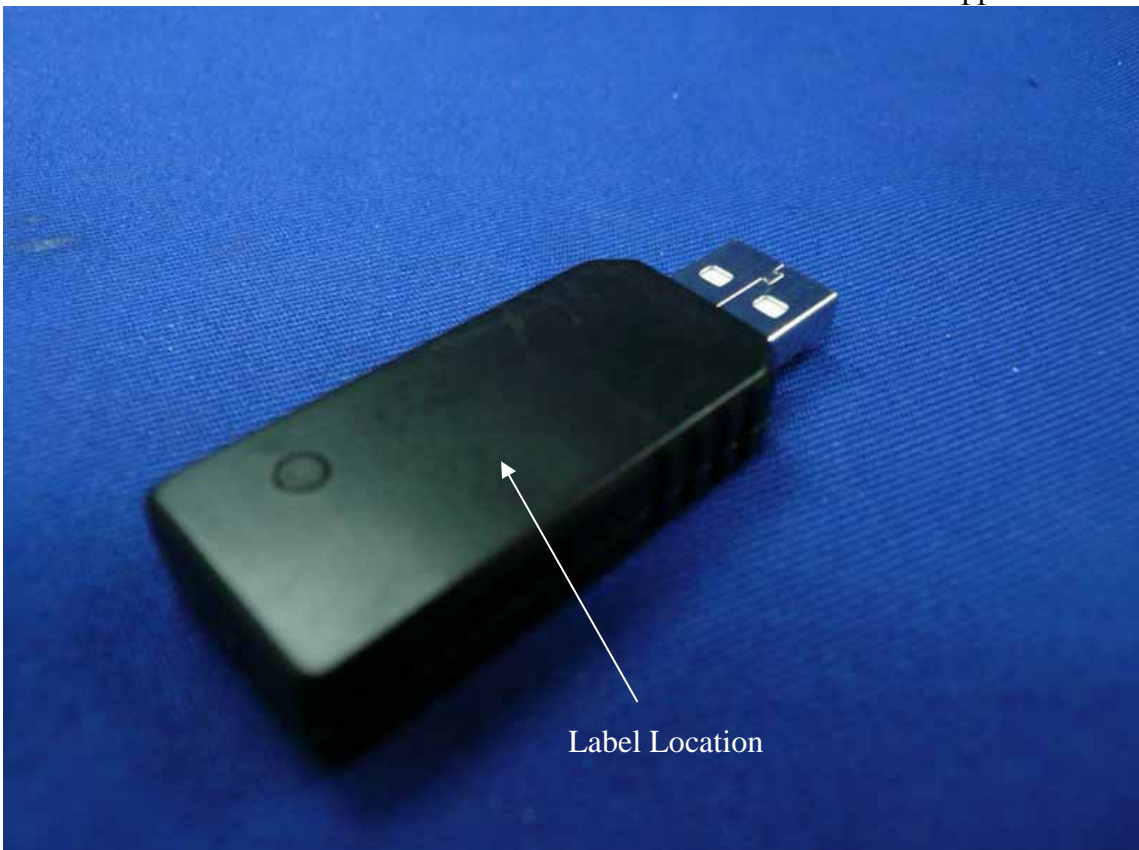

Figure 3
Inside of the EUT



Figure 4
Inside of the EUT

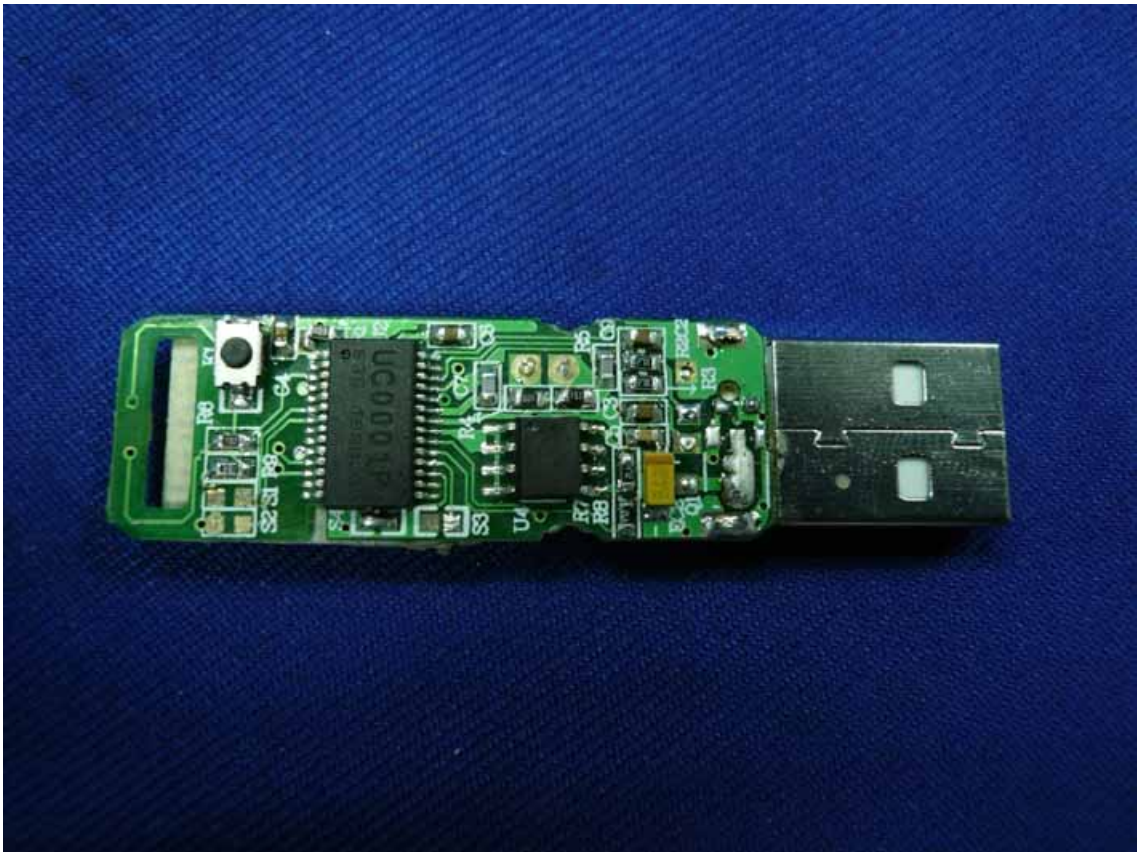

Figure 5
Inside of the EUT

