

6

5

4

3

2

1

REVISION RECORD			
LTR	ECO NO.	APPROVED	DATE

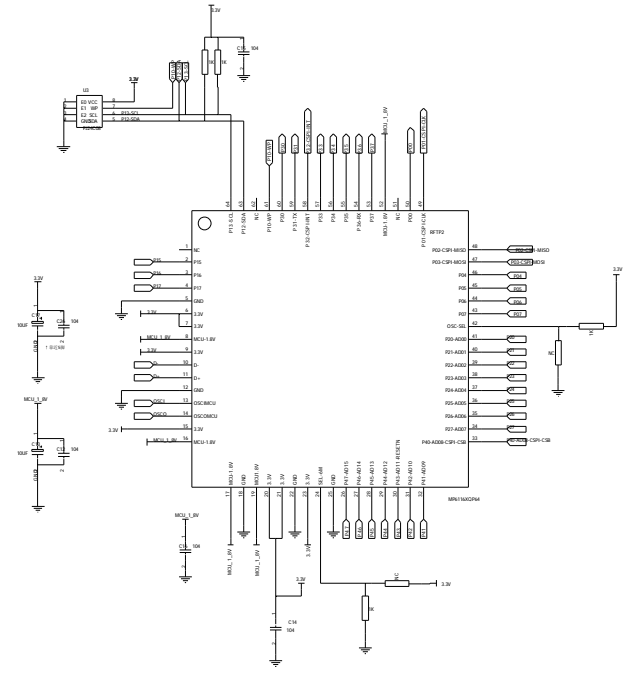
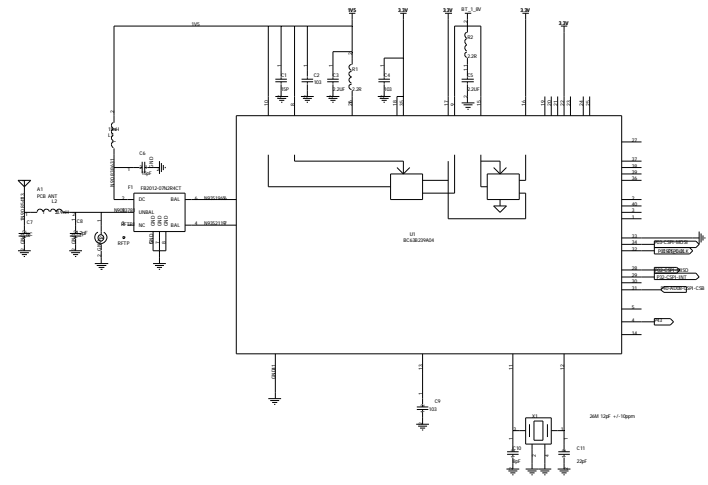
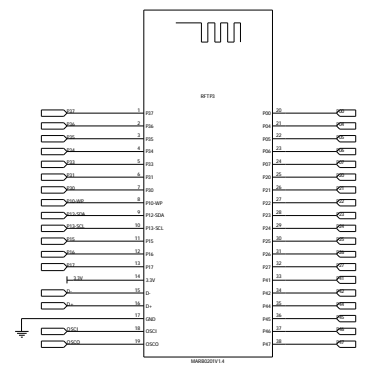

COMPANY:				
TITLE:				
DESIGN:	DATE:	CODE:	SIZE:	DRAWING NO.:
CHECKED:	DATE:	SCALE:	REV:	REV:
QUALITY CONTROL:	DATE:	D		
RELEASED:	DATE:	SHEET 1		