

## ***FCC EVALUATION REPORT FOR CERTIFICATION***

**Applicant: Ohsung Electronics Co., Ltd.**

**Date of Issue: March 02, 2016**

**#181 Gongdan-dong, Gumi-si, Gyeongsangbuk-Do,**

**Order Number: GETEC-C1-16-110**

**Republic of Korea.**

**Test Report Number: GETEC-E3-16-010**

**Attn : Mr. Ju-Ho Yoon / Q.A Team**

**Test Site: GUMI UNIVERSITY EMC CENTER**

**(Test firm Registration Number: 269701)**

**FCC ID. : OZ5URCMX990I**

**Applicant : Ohsung Electronics Co., Ltd.**

**Rule Part(s) : FCC Part 15 Subpart C-Intentional Radiator § 15.231**  
**Equipment Class : Remote Control Transmitter (DSC)**  
**EUT Type : RF REMOTE CONTROLLER**  
**Type of Authority : Certification**  
**Model Name : MX-990i**  
**Trade Name : UNIVERSAL Remote Control**

**This equipment has been shown to be in compliance with the applicable technical standards as indicated in the measurement report and was tested in accordance with the measurement procedures specified in ANSI C63.10 (2013)**

**I attest to the accuracy of data. All measurements reported herein were performed by me or were made under my supervision and are correct to the vest of my knowledge and belief. I assume full responsibility for the completeness of these measurements and vouch for the qualifications of all persons taking them.**

**Tested by,**

**Reviewed by,**

*Soon Hoon*

**Soon-Hoon Jeong, Senior Engineer**  
**GUMI UNIVERSITY EMC CENTER**

*Jae-Hoon Jeong*

**Jae-Hoon Jeong, Technical Manager**  
**GUMI UNIVERSITY EMC CENTER**



## CONTENTS

<b>1. GENERAL INFORMATION .....</b>	<b>4</b>
<b>2. INTRODUCTION .....</b>	<b>5</b>
<b>3. PRODUCT INFORMATION .....</b>	<b>6</b>
<b>3.1 DESCRIPTION OF EUT.....</b>	<b>6</b>
<b>3.2 SUPPORT EQUIPMENT / CABLES USED .....</b>	<b>7</b>
<b>3.3 MODIFICATION ITEM(S).....</b>	<b>7</b>
<b>4. ANTENNA REQUIREMENT - §15.203 .....</b>	<b>8</b>
<b>4.1 DESCRIPTION OF ANTENNA.....</b>	<b>8</b>
<b>5. DESCRIPTION OF TESTS.....</b>	<b>8</b>
<b>5.1 TEST CONDITION.....</b>	<b>8</b>
<b>5.2 CONDUCTED EMISSION .....</b>	<b>9</b>
<b>5.3 RADIATED EMISSION.....</b>	<b>10</b>
<b>5.4 DUTY CYCLE CORRECTION .....</b>	<b>11</b>
<b>5.5 OCCUPIED BANDWIDTH .....</b>	<b>11</b>
<b>6. CONDUCTED EMISSION.....</b>	<b>12</b>
<b>6.1 OPERATING ENVIRONMENT .....</b>	<b>12</b>
<b>6.2 TEST SET-UP .....</b>	<b>12</b>
<b>6.3 MEASUREMENT UNCERTAINTY.....</b>	<b>12</b>
<b>6.4 LIMIT .....</b>	<b>13</b>
<b>6.5 TEST EQUIPMENT USED.....</b>	<b>13</b>
<b>6.6 TEST DATA FOR CONDUCTED EMISSION .....</b>	<b>13</b>
<b>7. DUTY CYCLE CORRECTION.....</b>	<b>15</b>
<b>7.1 OPERATING ENVIRONMENT .....</b>	<b>15</b>
<b>7.2 TEST SET-UP .....</b>	<b>15</b>
<b>7.3 TEST EQUIPMENT USED.....</b>	<b>15</b>
<b>7.4 TEST RESULT OF DUTY CYCLE.....</b>	<b>15</b>
<b>8. ACTIVATION TIME.....</b>	<b>17</b>
<b>8.1 OPERATING ENVIRONMENT .....</b>	<b>17</b>
<b>8.2 LIMIT .....</b>	<b>17</b>
<b>8.3 TEST EQUIPMENT USED.....</b>	<b>17</b>
<b>8.4 TEST RESULT OF ACTIVATION TIME .....</b>	<b>17</b>
<b>9. RADIATED EMISSION .....</b>	<b>18</b>
<b>9.1 OPERATING ENVIRONMENT .....</b>	<b>18</b>
<b>9.2 TEST SET-UP.....</b>	<b>18</b>
<b>9.3 MEASUREMENT UNCERTAINTY .....</b>	<b>18</b>
<b>9.4 LIMIT .....</b>	<b>19</b>
<b>9.5 TEST EQUIPMENT USED.....</b>	<b>19</b>
<b>9.6 TEST DATA FOR RADIATED EMISSION.....</b>	<b>20</b>
<b>10. OCCUPIED BANDWIDTH MEASUREMENT.....</b>	<b>22</b>
<b>10.1 OPERATING ENVIRONMENT .....</b>	<b>22</b>
<b>10.2 TEST SET-UP .....</b>	<b>22</b>
<b>10.3 LIMIT .....</b>	<b>22</b>
<b>10.4 TEST EQUIPMENT USED.....</b>	<b>22</b>
<b>10.5 TEST RESULT OF OCCUPIED BANDWIDTH.....</b>	<b>22</b>





**11. SAMPLE CALCULATIONS.....24**  
 11.1 EXAMPLE 1 : .....24  
 11.2 EXAMPLE 2 : .....24  
**12. RECOMMENDATION & CONCLUSION.....25**

- APPENDIX A – ATTESTATION STATEMENT**
- APPENDIX B – ID SAMPLE LABEL & LOCATION**
- APPENDIX C – BLOCK DIAGRAM**
- APPENDIX D – SCHEMATIC DIAGRAM**
- APPENDIX E – TEST SET-UP PHOTOGRAPHS**
- APPENDIX F – EXTERNAL PHOTOGRAPHS**
- APPENDIX G – INTERNAL PHOTOGRAPHS**
- APPENDIX H – USER’S MANUAL**
- APPENDIX I – OPERATIONAL DESCRIPTION**
- APPENDIX J – DECLARATION OF CONFORMITY LETTER**





*Scope: Measurement and determination of electromagnetic emissions (EME) of radio frequency devices including intentional and / or unintentional radiators for compliance with technical rules and regulations of the Federal Communications Commission.*

## 1. General Information

**Applicant: Ohsung Electronics CO., LTD.**

**Applicant Address: #181 Gongdan-dong, Gumi-si, Gyeongsangbuk-Do, Republic of Korea.**

**Manufacturer: Ohsung Electronics CO., LTD.**

**Manufacturer Address: #181 Gongdan-dong, Gumi-si, Gyeongsangbuk-Do, Republic of Korea.**

**Contact Person: Mr. Ju-Ho Yoon / Q.A. Team**

**Tel. Number: +82-54-468-0831 Fax Number: +82-54-461-8368**

- **FCC ID.** OZ5URCMX990I
- **Equipment Class** Remote Control Transmitter (DSC)
- **EUT Type** RF REMOTE CONTROLLER
- **Model Name** MX-990i
- **Trade Name** UNIVERSAL Remote Control
- **Serial Number** Prototype
- **Rule Part(s)** FCC Part 15 Subpart C
- **Type of Authority** Certification
- **Test Procedure(s)** ANSI C63.10 (2013)
- **Dates of Test** February 22 ~ 29, 2016
- **Place of Test** GUMI UNIVERSITY EMC CENTER (FCC Test firm Registration No.: 269701)  
37 Yaeun-ro, Gumi-si, Gyeongsangbuk-do, 730-711, Republic of Korea
- **Test Report Number** GETEC-E3-16-010
- **Dates of Issue** March 02, 2016





## 2. Introduction

The measurement procedure described in American National Standard for Methods of Measurement of Radio-Nose Emissions From Low-Voltage Electrical and Electronic Equipment in the Range of 9 kHz to 40 GHz (ANSI C63.10-2013) was used in determining radiated and conducted emissions emanating from **Ohsung Electronics CO., LTD. RF REMOTE CONTROLLER (Model Name: MX-990i) FCC ID.: OZ5URCMX990I**

These measurement tests were conducted at **GUMI UNIVERSITY EMC CENTER**.

The site address is 37 Yaeun-ro, Gumi-si, Gyeongsangbuk-do, 730-711, Republic of Korea.

This test site is one of the highest point of GUMI UNIVERSITY at about 200 km away from Seoul city and 40 km away from Daegu city. It is located in the valley surrounded by mountains in all directions where ambient radio signal conditions are quiet and a favorable area to measure the radio frequency interference on open field test site for the computing and ISM devices manufactures. The detailed description of the measurement facility was found to be in compliance with the requirements of FCC §2.948 according to ANSI C63.10 (2013)



Fig 1. The map above shows the GUMI UNIVERSITY in vicinity area.



### 3. Product Information

#### 3.1 Description of EUT

The Equipment under Test (EUT) is the **Ohsung Electronics CO., LTD.**  
**RF REMOTE CONTROLLER (Model Name: MX-990i) FCC ID.: OZ5URCMX990I**

- <b>Microprocessor</b>	: ARM9 454 MHz
- <b>RAM</b>	: 64 Mbyte Mobile DDR
- <b>NAND</b>	: 128 Mbyte
- <b>LCD</b>	: 2.4 Inch Screen (240 by 320) LCD, Backlighting by LED
- <b>Devices</b>	: Supports up to 255 Devices with text, less with heavy graphics
- <b>Usage Pages</b>	: Supports up to 255 Pages on each Device with text, less with heavy graphics usage
- <b>Macro Capability</b>	: Up to 255 steps each, however nesting is allowed
- <b>IR Range (Line of sight via infrared)</b>	: 30 to 50 feet, depending on the environment
- <b>RF Range (Radio Frequency)</b>	: 50 to 100 feet, depending on the environment
- <b>Battery</b>	: Lithium polymer, 1330mAh
- <b>Battery charging time</b>	: 5 Hours
- <b>Size</b>	: 8.98"(H) x 2.32"(W) x 0.874"(D)
- <b>Battery Warranty</b>	: 1 Year
- <b>Weight (with Battery loaded)</b>	: 6.21 oz
- <b>SMPS</b>	: 5 V / 1 A USB Connector
- <b>Highest Clock frequency</b>	: 24 MHz



### 3.2 Support Equipment / Cables used

#### 3.2.1 Used Support Equipment

Description	Manufacturer	Model Name	S/N & FCC ID
Charging Cradle	Ohsung Electronics Co., Ltd.	MX-990CG	S/N: None FCC ID.: None
AC/DC Adapter <sup>1)</sup>	MEILE GROUP LTD.	MLF-A00060501000U0021	S/N: None FCC ID.: None

1) Input rating: AC 100 ~ 240 V, 50/60 Hz

Output rating: DC 5 V, 1 A

See “Appendix E– Test Setup Photographs” for actual system test set-up

#### 3.2.2 System configuration

Description	Manufacturer	Model Name	S/N & FCC ID.
Li-ion Rechargeable Battery <sup>1)</sup>	Neonix Corporation	-	S/N: None FCC ID.: None

1) Output rating: DC 3.7 V / 1330 mAh

#### 3.2.3 Used Cable(s)

Cable Name	Condition	Description
None.	-	-

### 3.3 Modification Item(s)

- None





#### 4. Antenna Requirement - §15.203

An intentional radiator antenna shall be designed to ensure that no antenna other than that furnished by the applicant can be used with the device. The use of permanently attached antenna or of an antenna that uses a unique coupling to the intentional radiator shall be considered sufficient to comply with this requirement.

##### 4.1 Description of Antenna

The **Ohsung Electronics CO., LTD. / RF REMOTE CONTROLLER** comply with the requirement of §15.203 with a built-in PCB pattern antenna permanently attached to the transmitter.

#### 5. Description of tests

##### 5.1 Test Condition

- Test Voltage / Frequency:

RF Test: DC 3.7 V supplied from a Lithium battery.  
AC Line Conducted Emission: AC 120 V / 60 Hz

- Test Mode(s) are:

RF Test: Continuous RF transmitting mode  
AC Line Conducted Emission: Continuous RF transmitting and battery changing mode

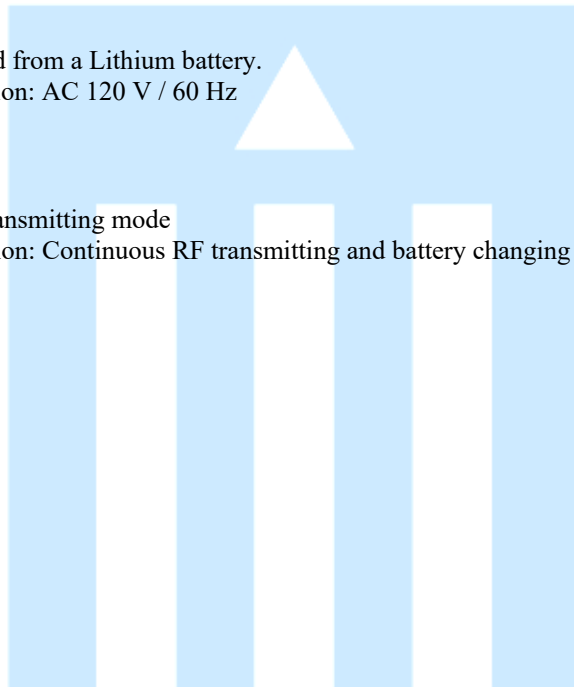





## 5.2 Conducted Emission

The Line conducted emission test facility is inside a 4 m × 8 m × 2.5 m shielded enclosure.

The EUT was placed on a non-conducting 1.0 m by 1.5 m table, which is 0.8 m in height and 0.4 m away from the vertical wall of the shielded enclosure.

The EUT is powered from the Rohde & Schwarz LISN (ESH2-Z5) and the support equipment is powered from the Rohde & Schwarz LISN (ESH3-Z5). Powers to the LISN are filtered by high-current high insertion loss power line filter.

Sufficient time for EUT, support equipment, and test equipment was allowed in order for them to warm up to their normal operating condition.

The RF output of the LISN was connected to the EMI test receiver (Rohde & Schwarz, ESCS30).

Exploratory measurements were conducted to identify the highest emission by operating the EUT in a range of typical modes of operation, cable positions, system configuration and arrangement.

Based on exploratory measurements, the final measurements were conducted at the worst test conditions.

Exploratory measurements were scanned using Peak mode of EMI Test receiver from 150 kHz to 30 MHz with 20 ms sweep time. The final measurements were measured with Quasi-Peak and Average mode.

The bandwidth of EMI Test Receiver was set to 9 kHz. Interface cables were connected to the available interface ports of the test unit. Excess cable lengths were bundled at center with 30 cm ~ 40 cm.

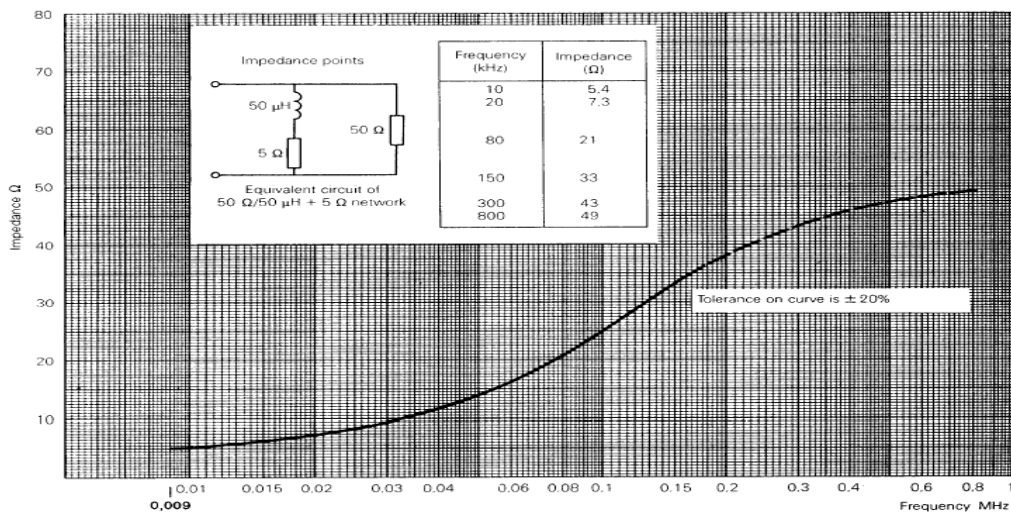

Fig 2. Impedance of LISN





### 5.3 Radiated Emission

Exploratory Radiated measurements were conducted at the 3m semi anechoic chamber in order to identify the highest emission by operating the EUT in a range of typical modes of operation, cable positions, system configuration and arrangement.

Based on exploratory measurements, the final measurements were conducted at the worst test conditions.

Final measurements of below 1GHz were made at 3m or 10 m Chamber that complies with CISPR 16/ANSI C63.10. Above 1GHz final measurements were conducted at the 3m Chamber only.

For measurements above 1GHz, the bottom side of 3m chamber was installed with absorbers in order to meet SVSWR Limit.

Exploratory measurements were scanned using Peak mode of EMI Test receiver and final measurements were measured with Quasi-Peak mode (Below 1GHz) and Peak & Average mode (Above 1GHz).

The measurements were performed by rotating the EUT 360° and adjusting the receive antenna height from 1.0 m to 4.0 m. All frequencies were investigated in both horizontal and vertical antenna polarity.

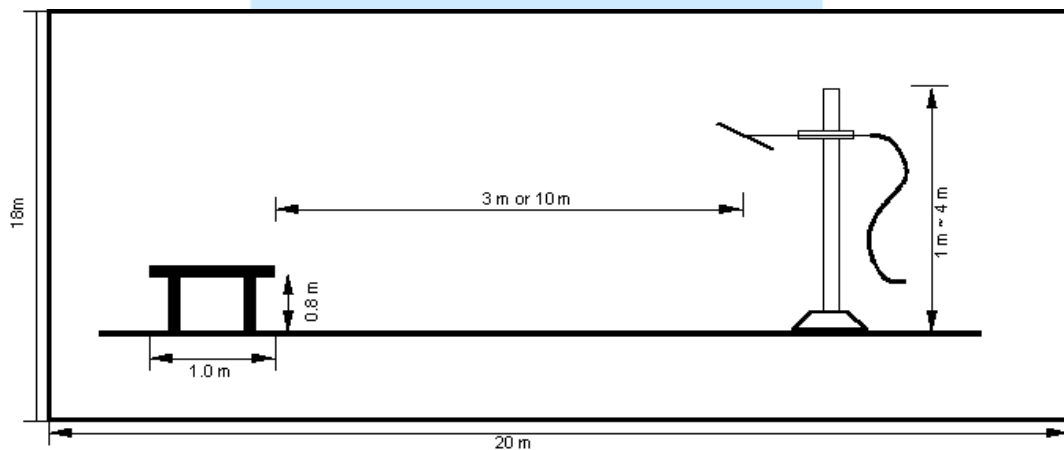

Fig 3. Dimensions of test site (Below 1GHz)

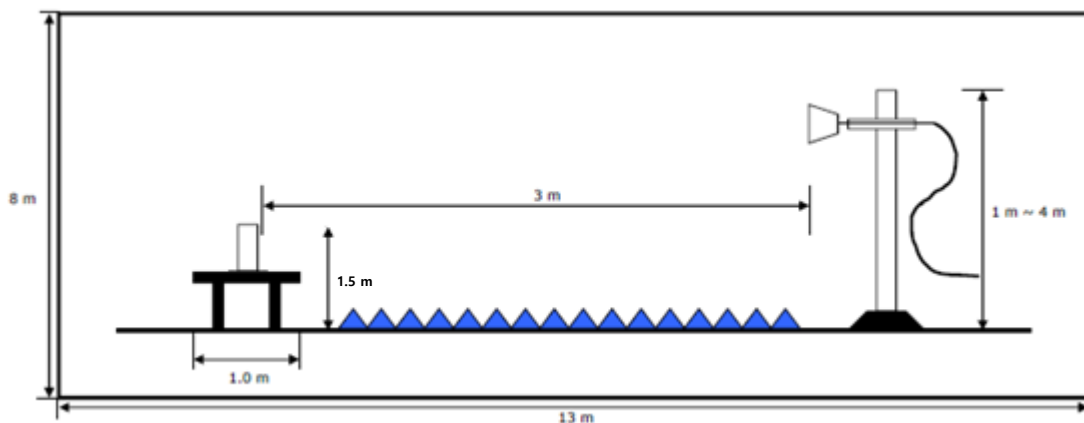

Fig 4. Dimensions of test site (Above 1GHz)





#### 5.4 Duty Cycle Correction

Measurements may be adjusted where pulsed RF is utilized to find the average level associated with a quantity.

This calculation is applied to limits for pulsed licensed and unlicensed devices.

For unlicensed intentional radiator under 47CFR Part 15 §15.35, all duty cycle measurements are compared to a 0.1 seconds. As an alternative (provided the transmitter operates for longer than 0.1 seconds) or in cases where the pulse train exceeds 0.1 seconds, the measured field strength shall be determined from the average absolute voltage during a 0.1 second interval during which the field strength is at its maximum value. The exact method of calculating the average field strength shall be submitted with any application for certification or shall be retained in the measurement data file for equipment subject to notification or verification.

On time =  $N_1L_1 + N_2L_2 + \dots + N_nL_n$ , where  $N_1$  is number of type 1 pulses,  $L_1$  is length of type 2 pulses, etc.

**Duty Cycle = On time/ Pulse train length or 100 ms**

#### 5.5 Occupied Bandwidth

Occupied bandwidth was performed by coupling the output of the EUT to the input of a spectrum analyzer.

The bandwidth of the emission shall be no wider than 0.25 % of the center frequency for device operating above 70 MHz and below 900 MHz. For device operating above 900 MHz, the emission shall be no wider than 0.5 % of the center frequency. The bandwidth is determined at the points 20 dB down from the modulated carrier.

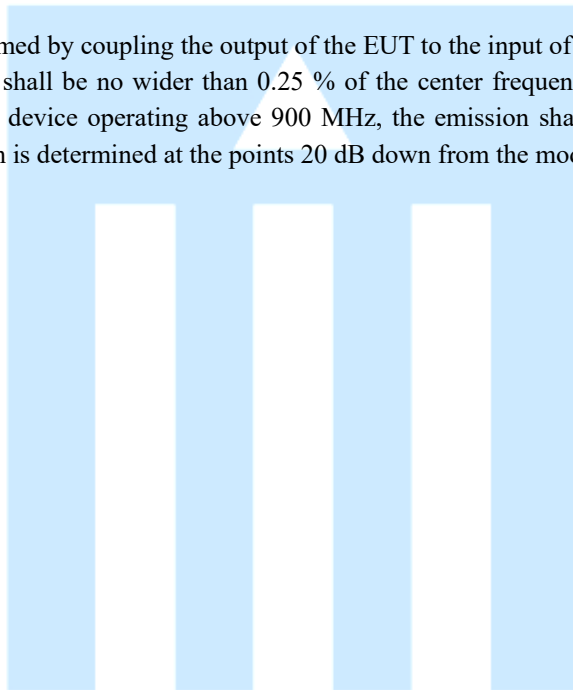



## 6. Conducted Emission

### 6.1 Operating Environment

Temperature : 22.2 °C  
Relative Humidity : 28.4 % R.H.

### 6.2 Test Set-up

The conducted emission measurements were performed in the shielded room.

The EUT was placed on wooden table, 0.8 m heights above the floor, 0.4 m from the reference ground plane (GRP) wall and 0.8 m from AMN & ISN.

AMN is bonded on horizontal reference ground plane.

The ground plane, which was electrically bonded to the shield room, ground system and all power lines entering the shield room, were filtered.

### 6.3 Measurement Uncertainty

The measurement uncertainty was calculated in accordance with ISO "Guide to the expression of uncertainty in measurement."

The measurement uncertainty was given with a confidence of 95 %.

Test Items	Uncertainty	Remark
Conducted emission (9 kHz ~ 150 kHz)	3.94 dB	Confidence level of approximately 95 % ( $k = 2$ )
Conducted emission (150 kHz ~ 30 MHz)	3.43 dB	Confidence level of approximately 95 % ( $k = 2$ )



#### 6.4 Limit

RFI Conducted	FCC Limit(dBμV/m) Class B	
	Quasi-Peak	Average
150 kHz ~ 0.5 MHz	66 ~ 56*	56 ~ 46*
0.5 MHz ~ 5 MHz	56	46
5 MHz ~ 30 MHz	60	50

\*Limits decreases linearly with the logarithm of frequency.

#### 6.5 Test Equipment used

Model Name	Manufacturer	Description	Serial Number	Due to Calibration
■ - ESCI	Rohde & Schwarz	EMI test receiver	100237	Apr 23. 2016
■ - ENV216	Rohde & Schwarz	LISN	100172	Apr 23. 2016
□- ENV216	Rohde & Schwarz	LISN	100173	Apr 23. 2016
□ - ISN T8	TESEQ. GmbH	ISN	24568	Apr 27. 2016

#### 6.6 Test data for Conducted Emission

- Test Date : Feb. 23, 2014
- Reference Standard : Part 15 Subpart C, Sec. 15.207
- Test Procedure(s) : ANSI C63.10 (2013)
- Operating Condition : RF transmitting with charging mode
- Frequency rage : 0.15MHz ~ 30 MHz
- Comment : None.



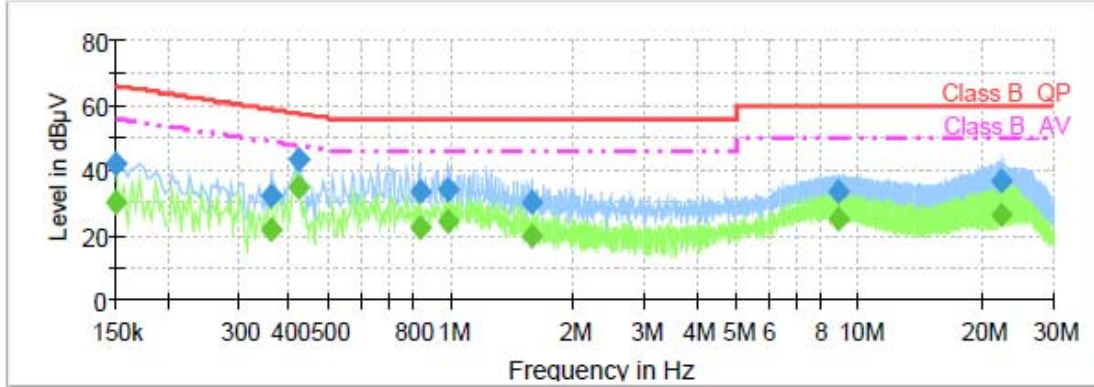

**Final Result 1**

Frequency (MHz)	QuasiPeak (dBµV)	Meas. Time (ms)	Bandwidth (kHz)	Filter	Line	Corr. (dB)	Margin (dB)	Limit (dBµV)	Comment
0.150000	42.0	100.0	9.000	Off	L1	9.7	24.0	66.0	
0.362681	31.8	100.0	9.000	Off	L1	9.7	26.8	58.7	
0.422381	43.0	100.0	9.000	Off	L1	9.7	14.4	57.4	
0.836550	33.7	100.0	9.000	Off	L1	9.7	22.3	56.0	
0.985800	34.0	100.0	9.000	Off	L1	9.7	22.0	56.0	
1.567875	30.0	100.0	9.000	Off	L1	9.8	26.0	56.0	
8.892319	33.4	100.0	9.000	Off	L1	9.9	26.6	60.0	
22.313625	36.4	100.0	9.000	Off	L1	10.2	23.6	60.0	

**Final Result 2**

Frequency (MHz)	CAverage (dBµV)	Meas. Time (ms)	Bandwidth (kHz)	Filter	Line	Corr. (dB)	Margin (dB)	Limit (dBµV)	Comment
0.150000	30.2	100.0	9.000	Off	L1	9.7	25.8	56.0	
0.362681	21.6	100.0	9.000	Off	L1	9.7	27.0	48.7	
0.422381	34.7	100.0	9.000	Off	L1	9.7	12.7	47.4	
0.836550	22.4	100.0	9.000	Off	L1	9.7	23.6	46.0	
0.985800	24.5	100.0	9.000	Off	L1	9.7	21.5	46.0	
1.567875	19.6	100.0	9.000	Off	L1	9.8	26.4	46.0	
8.892319	25.1	100.0	9.000	Off	L1	9.9	24.9	50.0	
22.313625	26.3	100.0	9.000	Off	L1	10.2	23.7	50.0	

< Fig 5. Conducted emission result >





## 7. Duty Cycle Correction

### 7.1 Operating Environment

Temperature : 21.5 °C  
 Relative humidity : 42.3 % R.H.

### 7.2 Test Set-up

The spectrum analyzer was set to Zero span and the video triggered to collect the pulse train of the modulation. Calculations of the duty cycle correction factor were obtained from time data provided by the plots.

### 7.3 Test Equipment used

Model Name	Manufacturer	Description	Serial Number	Due to Calibration
■ - FSP	Rohde & Schwarz	EMI Test Receiver	101431	Jan. 04, 2017
■ - 56-10	Weinschel	10dB Attenuator	53184	Apr. 26, 2016

### 7.4 Test result of Duty Cycle

- Test Date : Feb. 22, 2016
- Reference Standard : Part 15 Subpart C, Sec. 15.231 (a)(1)
- Operating Condition : RF transmitting mode
- Spectrum Resolution Bandwidth (3 dB) : 1MHz

#### 7.4.1 Test Frequency: 433.92 MHz

Define of duty cycle

- Number of Code groups per Pulse train or 100 ms = 2
- Number of Pulse#1(Head) = 338
- Width of Pulses = 0.011 2 ms
- Number of Pulse#2(Data) = 693
- Width of Pulses = 0.011 187 5 ms

Calculation of duty cycle

- Total width of pulse train:  $(338 \times 0.011\ 2\ \text{ms}) + (693 \times 0.011\ 187\ 5\ \text{ms}) = 11.538\ 54\ \text{ms}$
- Duty Cycle (%):  $11.538\ 54\ \text{ms} / 100\ \text{ms} = 0.115\ 385\ \text{ms} \times 100 = 11.538\ 54\ \%$
- Duty Cycle (dB):  $20 \times \log(\text{duty}) = 20 \times \log(0.115\ 385) = -18.76\ \text{dB}$

Fundamental Frequency	Total width of ON-Time	Duty Cycle (%)	Duty Cycle (dB)
433.92 MHz	11.54 ms	11.54%	-18.76 dB





### 7.4.2 Test Plots

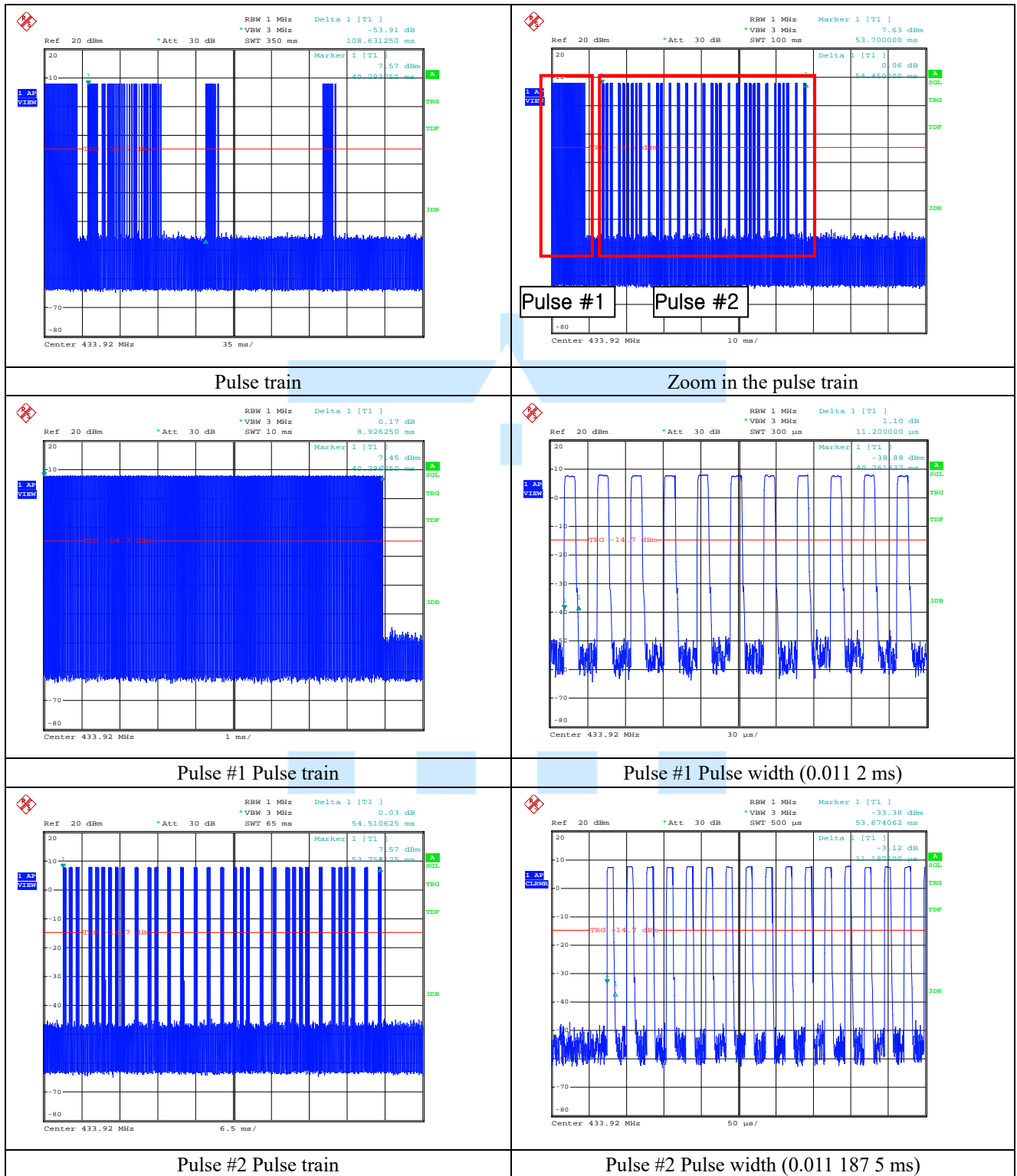

< Fig 6. Duty Cycle >







## 8. Activation time

### 8.1 Operating Environment

Temperature : 21.5 °C  
 Relative humidity : 42.3 % R.H.

### 8.2 Limit

A manually operated transmitter shall employ a switch that will automatically deactivate the transmitter within not more than 5 seconds of being released.

### 8.3 Test Equipment used

Model Name	Manufacturer	Description	Serial Number	Due to Calibration
■ - FSP	Rohde & Schwarz	EMI Test Receiver	101431	Jan. 04, 2017
■ - 56-10	Weinschel	10dB Attenuator	53184	Apr. 26, 2016

### 8.4 Test result of Activation time

- Test Date : Feb. 22, 2016
- Reference Standard : Part 15 Subpart C, Sec. 15.35
- Operating Condition : RF transmitting mode
- Spectrum Resolution Bandwidth (6 dB) : 100 kHz

Fundamental Frequency	Activate ON-Time	Limit	Result
433.92 MHz	4.94 s	< 5 s	PASS

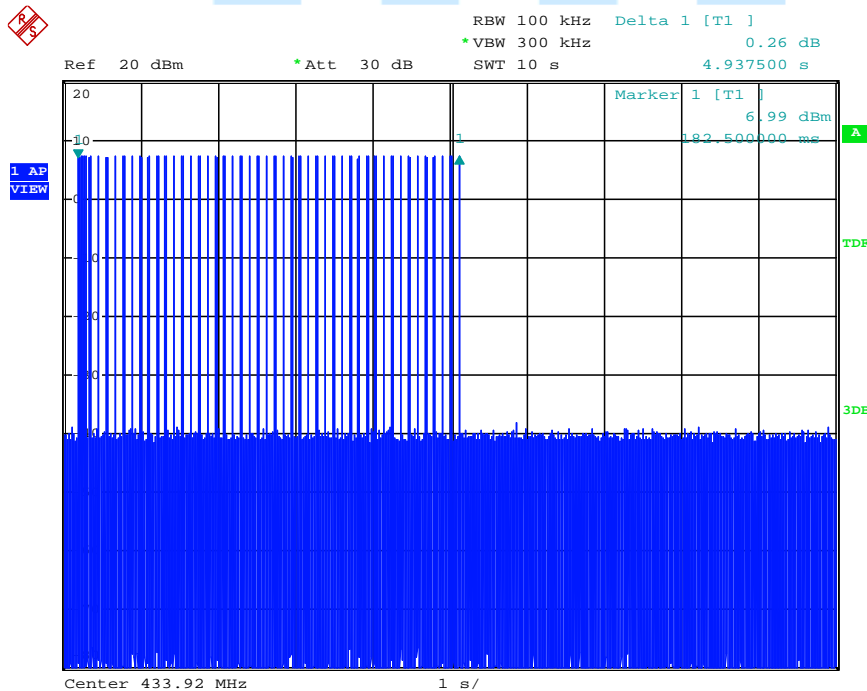

Date: 22.FEB.2016 16:06:33

< Fig 7. Activation time >





## 9. Radiated Emission

### 9.1 Operating environment

Temperature : 16.1 °C  
 Relative humidity : 27.4 % R.H.

### 9.2 Test set-up

A preliminary and final measurement was at 3 m anechoic chamber.

The EUT was placed on a non-conducting table.

For emissions testing at or below 1 GHz, the table height is 80 cm above the reference ground plane.

For emission measurements above 1 GHz, the table height is 1.5 m.

The turntable with EUT was rotated 360°, and the antenna was varied in height between 1.0 m and 4.0 m in order to determine the maximum emission levels.

This procedure was performed for both horizontal and vertical polarization of the receiving antenna.

### 9.3 Measurement uncertainty

The measurement uncertainty was calculated in accordance with ISO “Guide to the expression of uncertainty in measurement”.

The measurement uncertainty was given with a confidence of 95 %.

Test items(Anechoic Chamber)	Uncertainty	Remark
Radiated emission (30 MHz ~ 300 MHz, 3 m, Vertical)	4.66 dB	Confidence level of approximately 95 % ( $k = 2$ )
Radiated emission (30 MHz ~ 300 MHz, 3 m, Horizontal)	4.65 dB	Confidence level of approximately 95 % ( $k = 2$ )
Radiated emission (300 MHz ~ 1 000 MHz, 3 m, Vertical)	4.91 dB	Confidence level of approximately 95 % ( $k = 2$ )
Radiated emission (300 MHz ~ 1 000 MHz, 3 m, Horizontal)	4.88 dB	Confidence level of approximately 95 % ( $k = 2$ )
Radiated emission (1 000 MHz ~ 6 000 MHz, 3 m)	5.32 dB	Confidence level of approximately 95 % ( $k = 2$ )





**9.4 Limit**

Fundamental Frequency (MHz)	Field strength of Fundamental			Field strength of Spurious Emission	
	$\mu\text{V/m}$	$\text{dB}\mu\text{V/m}$	$\mu\text{V/m}$	$\mu\text{V/m}$	$\text{dB}\mu\text{V/m}$
40.66 ~ 40.7	2 250	67.04		225	47.04
70 ~ 130	1 250	61.94		125	41.94
130 ~ 174	1 250 to 3 750	61.94 to 71.48	56.818 18(F)-6136.363 6	125 to 375	41.94 to 51.48
174 ~ 260	3 750	71.48		375	51.48
260 ~ 470	3 750 to 12 500	71.48 to 81.94	41.666 7(F)-7083.333 3	375 to 1 250	51.48 to 61.94
Above 470	12 500	81.94		1 250	61.94
Restricted Band	N/A			500	54.0

**9.5 Test Equipment used**

Model Name	Manufacturer	Description	Serial Number	Due to Calibration
■ - ESIB26	Rohde & Schwarz	EMI Test Receiver	830482/010	Apr. 23, 2016
■ - VULB9160	Schwarzbeck	Broadband Test Antenna	3193	Mar. 25. 2016
■ - BBHA9120D	Schwarzbeck	Horn Antenna	207	Mar. 06. 2016
■ - MCU066	maturo GmbH	Position Controller	1390306	N/A
■ - TT2.5SI	maturo GmbH	Turntable	1390307	N/A
■ - AM 4.0	maturo GmbH	Antenna Mast	1390308	N/A
■ - AFS 44 00101800-25-10P-44	MITEQ	Preamplifier	1258943	Jan. 05. 2017





### 9.6 Test data for Radiated Emission

- Test Date : Feb 23 ~ 29, 2016
- Reference Standard : Part 15 Subpart C, Sec.15.231
- Measuring Distance : 3 m
- Note : Through three orthogonal axes were investigated and the worst case is reported.

- Measurement

Frequency range	30 MHz ~ 1 GHz	Above 1 GHz
Detector mode	Quasi peak	Peak / Average
Resolution bandwidth	120 kHz	1 MHz

#### 9.6.1 Operating condition: Continuous RF transmitting mode (433.92 MHz)

- ♦ Field Strength of the fundamental & harmonic frequencies.

Frequency (MHz)	Measurement Level					Limit		Margin		Positioning System		
	Reading (dBuV)	Tranduce (dB/m)	Duty cycle (dB)	Peak (dBuV/m)	Average (dBuV/m)	Peak (dBuV/m)	Aveage (dBuV/m)	Peak (dBuV/m)	Average (dBuV/m)	Pol. (H/V)	Height (cm)	Angle (deg)
<b>Fundamental</b>												
433.92	79.46	20.10	-18.76	99.56	80.80	100.83	80.83	1.27	0.02	H	200	258
<b>Spurious</b>												
867.73	20.12	27.65	-18.76	47.77	29.01	80.83	60.83	33.06	31.81	H	100	274
1301.69	71.54	-30.02	-18.76	40.27	22.76	74.00	54.00	32.48	31.24	V	107	247
1735.73	79.17	-27.73	-18.76	49.44	32.68	80.83	60.83	29.39	28.14	V	207	33
2169.37	84.82	-26.48	-18.76	54.31	39.58	80.83	60.83	22.49	21.24	H	100	344
2603.28	88.88	-25.53	-18.76	61.01	44.59	80.83	60.83	17.48	16.23	H	197	338
3037.32	83.43	-24.54	-18.76	60.52	40.13	80.83	60.83	21.94	20.69	H	125	344
3470.97	91.31	-23.46	-18.76	65.89	49.09	80.83	60.83	12.98	11.73	H	148	206
3904.87	84.35	-22.98	-18.76	61.01	42.61	74.00	54.00	12.63	11.39	H	121	297
4338.92	93.81	-22.66	-18.76	68.20	52.39	74.00	54.00	2.85	1.61	H	100	173

\*Comment ; below 1GHz : Tranduce = ANT factor + cable loss  
 above 1GHz : Tranduce = ANT factor + cable loss + AMP gain

Note: "H": Horizontal, "V": Vertical





♦ Field Strength of the spurious emission except the fundamental and harmonic frequencies

Frequency (MHz)	Measurement Level				Limit (dBµV/m)	Margin (dB)	Positioning System			
	Reading		Antenna	Cable			Test Result	Pol. (H/V)	Height (cm)	Angle (°)
	Value(dBµV)	Factor(dB/m)	Loss(dB)	(dBµV/m)						
32.18	20.86	11.95	1.13	33.94	40.00	6.06	V	150	256	
262.25	16.64	12.50	3.24	32.38	46.00	13.62	H	100	71	
595.19	17.01	18.63	4.92	40.56	46.00	5.44	H	150	263	

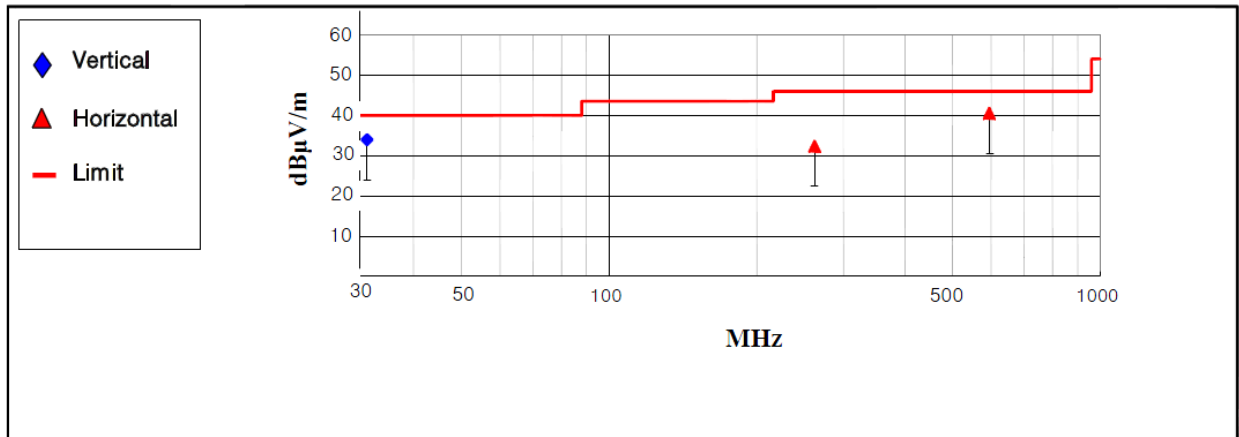

< Fig 8. Radiated emission result (30 MHz ~ 1 000 MHz) >

♦ Field Strength of the spurious emission except the harmonic frequencies

Frequency (MHz)	Measurement Level					Limit (dBµV/m)		Margin (dB)		Positioning System		
	Reading Value (dBµV/m)		AF	AMP / CL	Test Result (dBµV/m)	Peak	Average	Peak	Average	Pol. (H/V)	Height (cm)	Angle (°)
	Peak	Average	(dB/m)	(dB)	Peak							
<b>Not found critical peak</b>												

< Fig 9. Radiated emission result (1 GHz ~ 5 GHz) >





## 10. Occupied Bandwidth Measurement

### 10.1 Operating Environment

Temperature : 17.0 °C  
 Relative humidity : 27.3 %R.H.

### 10.2 Test Set-up

This measurement is performed with the antenna located close enough to give a full-scale deflection of the modulated carrier on the spectrum analyzer. The plot is taken at 200 kHz/division frequency span, 10 kHz 3 dB resolution bandwidth and 5 dB/division logarithmic display from an ESI spectrum analyzer.

The measuring bandwidth shall be set to a value greater than 5 % of the allowed bandwidth (ANSI C63.10-2013)

### 10.3 Limit

Frequency Range(MHz)	Occupied Bandwidth Limit
70 ~ 900	0.25 %
> 900	0.5 %

### 10.4 Test Equipment used

Model Name	Manufacturer	Description	Serial Number	Due to Calibration
■ - ESIB26	Rohde & Schwarz	EMI Test Receiver	830482/010	Apr. 23, 2016
■ - VULB9160	Schwarzbeck	Bi-log antenna	3193	Mar. 25, 2016

### 10.5 Test result of occupied bandwidth

- Test Date : Feb 18, 2016  
 - Reference standard : Part 15 Subpart C, Sec. 15.231  
 - Operating condition : RF transmitting mode  
 - Spectrum resolution bandwidth(3 dB) : 10 kHz





### 10.5.1 Test Frequency: 433.92 MHz

Allowed Bandwidth: Test frequency  $\times 0.0025 = 433.92 \text{ MHz} \times 0.0025 = 1084.8 \text{ kHz}$

Fundamental Frequency	Bandwidth	Allowed Bandwidth	Result
433.92 MHz	978.28 kHz	1084.8 kHz	PASS

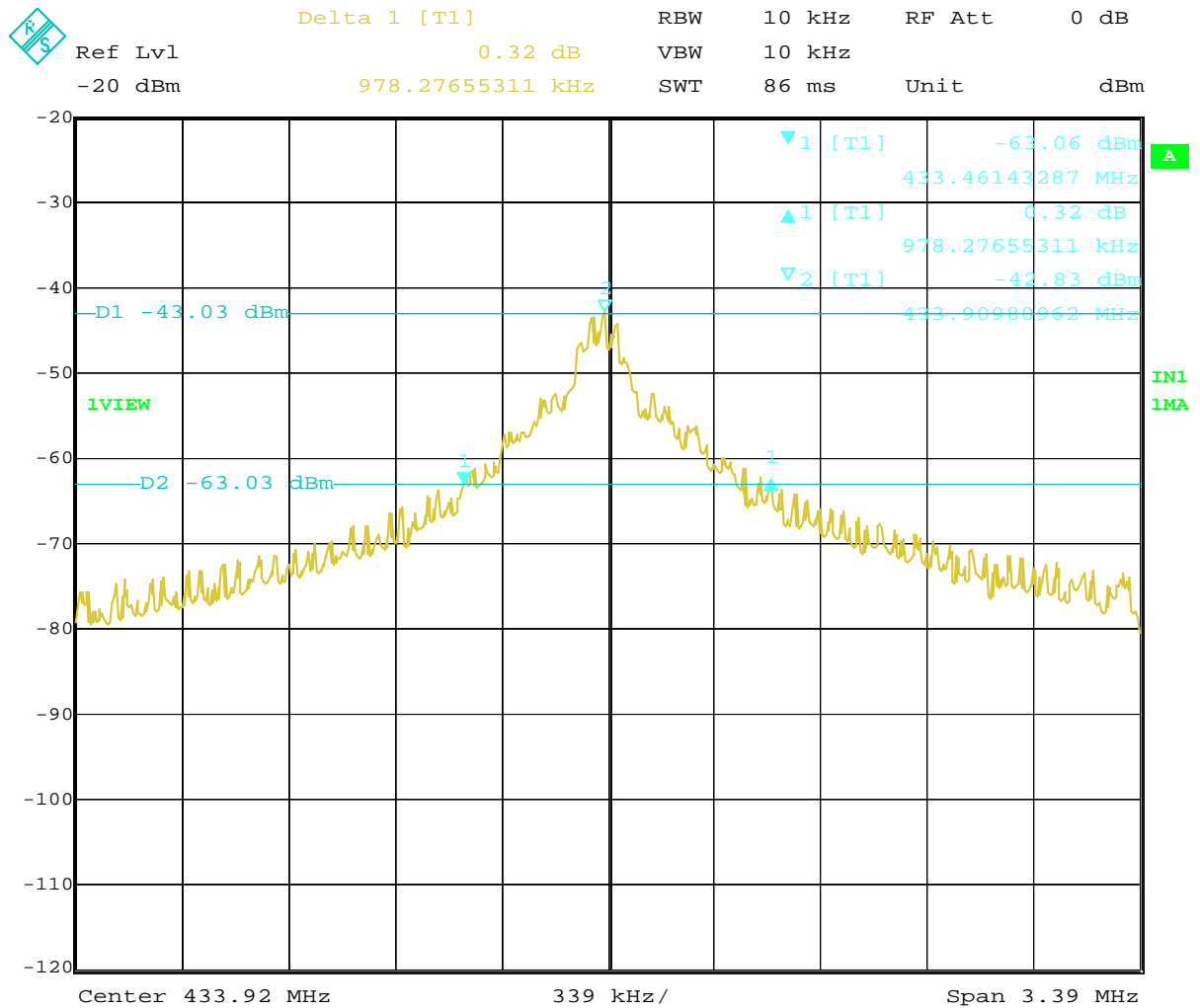

Date: 18.FEB.2016 12:37:45

< Fig 10. Occupied bandwidth >





## 11. Sample Calculations

$$\begin{aligned} \text{dB}\mu\text{V} &= 20 \text{ Log}_{10}(\mu\text{V}/\text{m}) \\ \text{dB}\mu\text{V} &= \text{dBm} + 107 \\ \mu\text{V} &= 10^{(\text{dB}\mu\text{V}/20)} \end{aligned}$$

### 11.1 Example 1 :

#### ■ 20.3 MHz

<b>Class B Limit</b>	= 250 $\mu\text{V}$ = 48 dB $\mu\text{V}$
<b>Reading</b>	= 39.2 dB $\mu\text{V}$
$10^{(39.2\text{dB}\mu\text{V}/20)}$	= 91.2 $\mu\text{V}$
<b>Margin</b>	= 48 dB $\mu\text{V}$ - 39.2 dB $\mu\text{V}$ = 8.8 dB

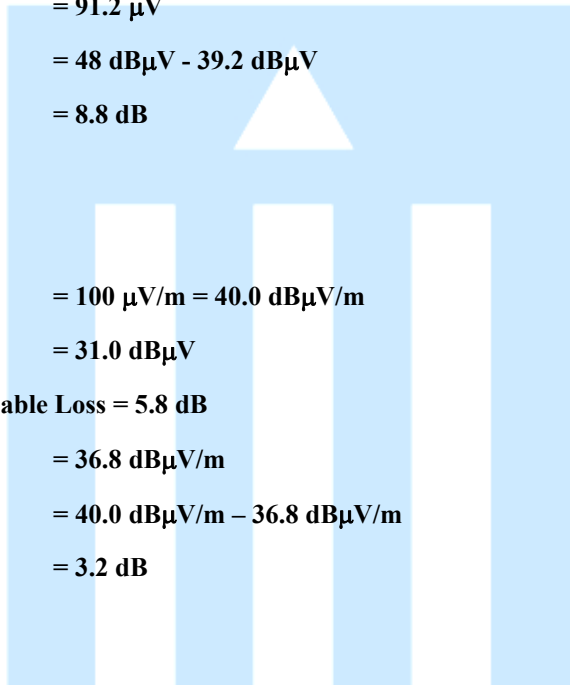

### 11.2 Example 2 :

#### ■ 66.7 MHz

<b>Class B Limit</b>	= 100 $\mu\text{V}/\text{m}$ = 40.0 dB $\mu\text{V}/\text{m}$
<b>Reading</b>	= 31.0 dB $\mu\text{V}$
<b>Antenna Factor + Cable Loss</b>	= 5.8 dB
<b>Total</b>	= 36.8 dB $\mu\text{V}/\text{m}$
<b>Margin</b>	= 40.0 dB $\mu\text{V}/\text{m}$ - 36.8 dB $\mu\text{V}/\text{m}$ = 3.2 dB







## 12. Recommendation & Conclusion

The data collected shows that the **Ohsung Electronics CO., LTD. RF REMOTE CONTROLLER (Model Name: MX-990i)** was complies with §15.231 of the FCC Rules.

- The end -

