



APPENDIX J
: ANTENNA SPECIFICATION

APPROVAL SHEET

MESSERS : (주)오성전자
DESCRIPTION : CHIP ANTENNA
MANUFACTURER : AMOTECH Co.,LTD
MODEL No. : ALA621C4
DATE : 2009.04.13.

APPROVAL		Prepared	Checked	Approved
	Name			
	Sign			



TEL) 054-462-8348 FAX)054-462-8351

경북 구미시 사곡동 354-18

리텍세미컴
대표이 문 호



APPROVAL SHEET

Type : Multilayer Chip Antenna
 Part No. : ALA621C4
 고객사 Model 명 : MX-880Z



오성 전자			

	Written	Checked		Approved
Amotech				
부서	개발	개발	품질	개발
이름	임기상	권정민	김준	김민석
날짜	3/5	3/5	3/5	3/5

2009. 03. 05

AMOTECH Co., Ltd.

Content

1. Revision History	3
2. Specifications	4
2.1 Electrical Specifications		
2.2 Mechanical Specifications		
2.3 Index method of Part No. & Lot No.		
3. Test Method	6
3.1 VSWR		
3.2 Radiation Gain		
4. Reliability Test	7
5. Soldering Recommend	8
5.1 Reflow profile for Pb-free		
5.2 PCB land pattern		
6. Structure and Material	9
6.1 Material		
6.2 Equivalent symbol		
7. Cautions	10
8. Packing Method	10
8.1 Carrier-tape		
8.2 Reel		
8.3 Packing box		
9. ROHS Test Report	12

1. Revision Record

Date	Title	Content	Remark
2009.03.05		New drawing up	

2. Specifications

2.1 Electrical specifications

No	Item	Spec.	Remark
1	Frequency Range	2400~2500	ISM Band
2	VSWR	Max. 2.5 : 1 @ 3103±45 MHz	On manual jig
3	Radiation Gain	Max. 0 dBi @azimuth co-pol.	Measured after matching on testboard
4	Radiation Pattern	Omni-directional	
5	Impedance	Nominal 50 Ω	

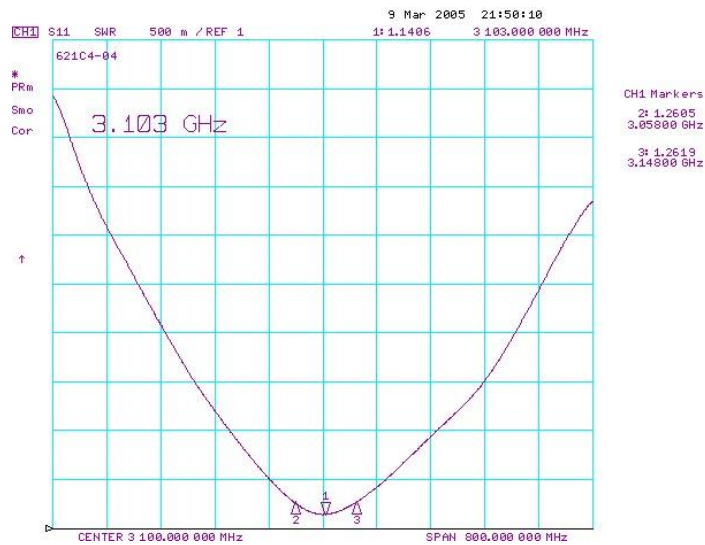

[VSWR : measured on manual jig]

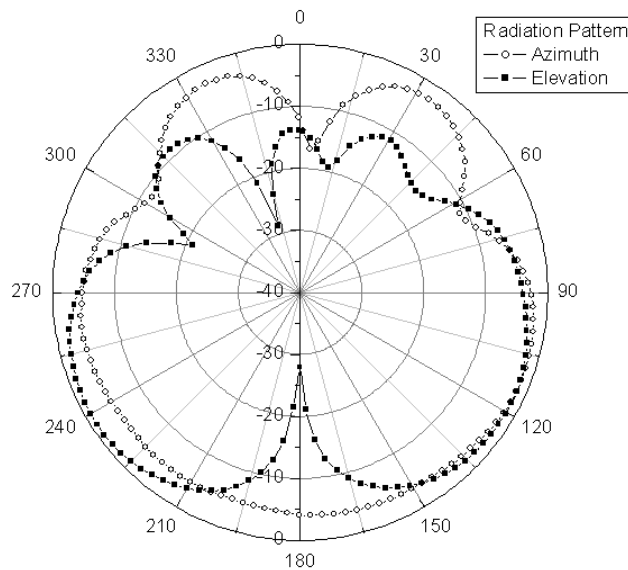

[Radiation Gain : Measured on Ref. Board]

2.2 Mechanical specifications

No	Item	Spec.		Unit
1	Dimensions	W	6.0 ± 0.3	mm
		D	2.0 ± 0.2	
		H	1.2 ± 0.2	
2	Unit Weight	46 ± 5		mg
3	Operation Temp.	$-30 \sim +70$		°C
4	Storage Temp.	$-40 \sim +85$		°C

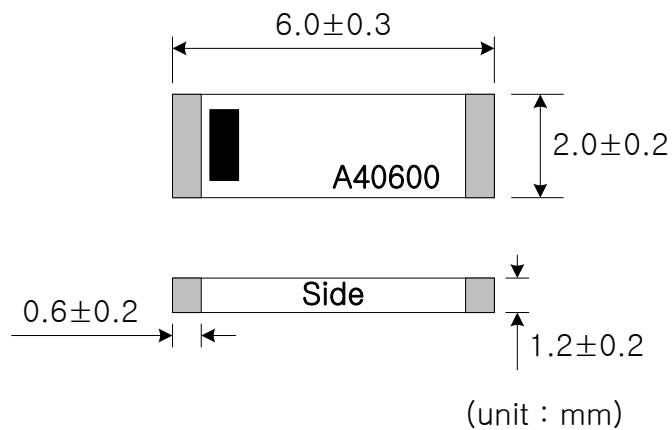

[Chip Antenna dimension]

2.3 Index method of Part No. & Lot No.

Part No.	<u>ALA</u>	621	<u>C4</u>		
	(1)	(2)	(3)		
(1) : Amotech Antenna					
(2) : Chip size					
(3) : Version & frequency					
Lot No.	<u>MA</u>	<u>06</u>	<u>A4</u>	<u>0506</u>	<u>01</u>
	(1)	(2)	(3)	(4)	(5)
(1) : Mass product Antenna					
(2) : Chip size					
(3) : Version & frequency					
(4) : Y/M					
(5) : Serial No. of product					

3. Test Method

3.1 VSWR

Equipment : Network Analyzer 8753ES

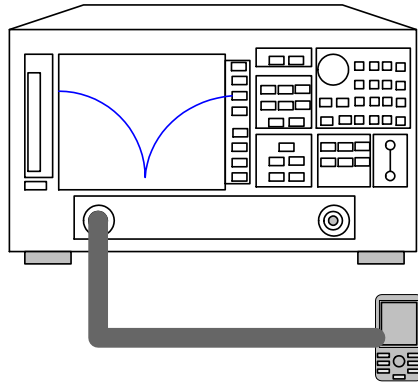

[Test procedure]

- a) Setup as shown picture.
- b) Calibrate Network Analyzer in frequency range of $f_0 \pm 400$ MHz, verify that the value of return loss(S_{11}) is under -55 dB with termination(50ohm)
- c) After connect a mobile set or manual jig for single chip antenna to Network Analyzer, measure the max. value of VSWR in frequency range of spec.

3.2 Radiation gain

Equipment : Anechoic chamber , Network Analyzer 8753ES

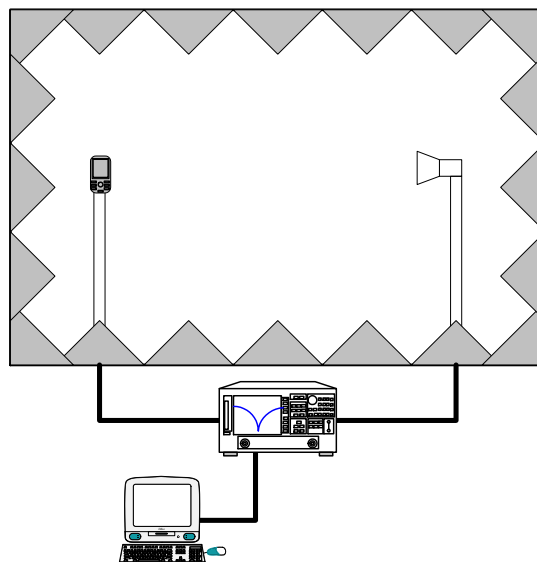

[Test procedure]

- a) Calibrate network analyzer and anechoic chamber using reference horn antenna.
- b) Set-up operation software (frequency, angle step, etc.)
- c) After connecting AUT on holder, measure radiation gain.

4. Reliability Test

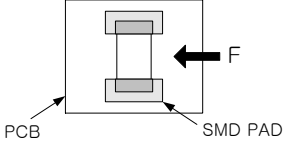
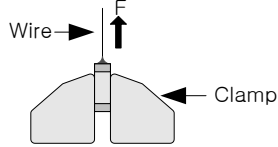
No	ITEM	TEST CONDITION	TEST REQUIREMENTS
1	Adhesive Strength of Termination	<p>1. Applied force on SMD chip till detached point from PCB.</p> 	<p>1. No mechanical damage by forces applied on the right. 2. Strength (F) > 5 kgf</p>
2	Tensile Strength	<p>1. Wire : 0.6~0.8 tined Cu wire</p> 	<p>1. No mechanical damage by forces applied on the right. 2. Strength (F) > 3 kgf</p>
3	Thermal Shock (Temperature Cycle)	<p>1. 1 cycle / step 1 : $-40 \pm 3^\circ\text{C}$, 30 min step 2 : $+125 \pm 3^\circ\text{C}$, 30 min 2. Number of cycle : 30 3. Measure after left for 48 hrs min. at room temperature</p>	<p>1. No visual damage 2. Within electric spec (VSWR)</p>
4	High Temperature Resistance	<p>1. Temperature : $+125 \pm 5^\circ\text{C}$ 2. Time : 1000 ± 24 hrs 3. Measure f_c after left for 24 hrs min. at room temperature</p>	<p>1. No visual damage 2. Within electric spec (VSWR)</p>
5	Low Temperature Resistance	<p>1. Temperature : $-40 \pm 5^\circ\text{C}$ 2. Time : 1000 ± 24 hrs 3. Measure f_c after left for 48 hrs min. at room temperature</p>	<p>1. No visual damage 2. Within electric spec (VSWR)</p>
6	Humidity (Steady Condition)	<p>1. Humidity : 85 % RH 1. Temperature : $+85 \pm 3^\circ\text{C}$ 2. Time : 1000 ± 24 hrs 3. Measure f_c after left for 48 hrs min. at room temperature</p>	<p>1. No visual damage 2. Within electric spec (VSWR)</p>

5. Soldering Recommend

5.1 Reflow profile for Pb-free

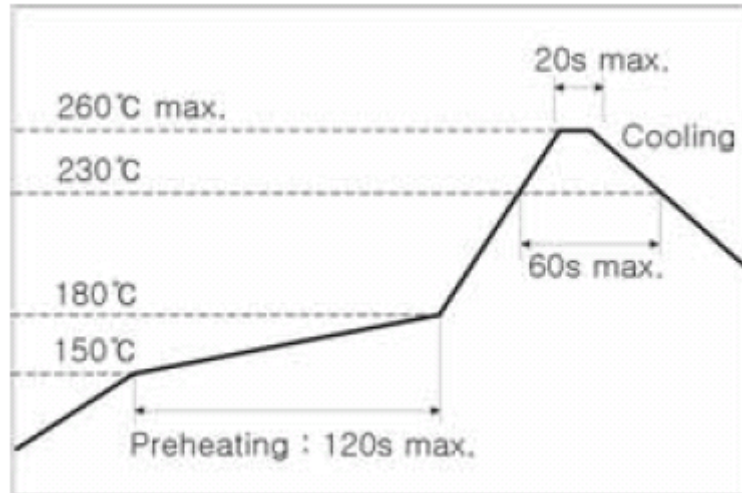

This product is designed for reflow soldering only. Do not use flow (wave) soldering.

- ① Use non-activated flux (Cl content 0.2% max.)
- ② Follow the recommended soldering conditions to avoid damage.
- ③ Reflow-cycle is max. 3 times.

5.2 PCB land pattern

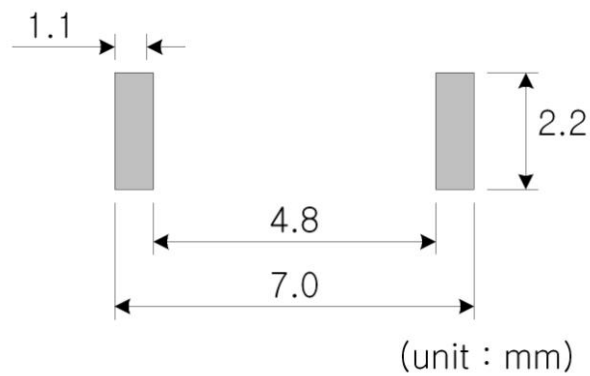

6. Structure and Material

6.1 Material

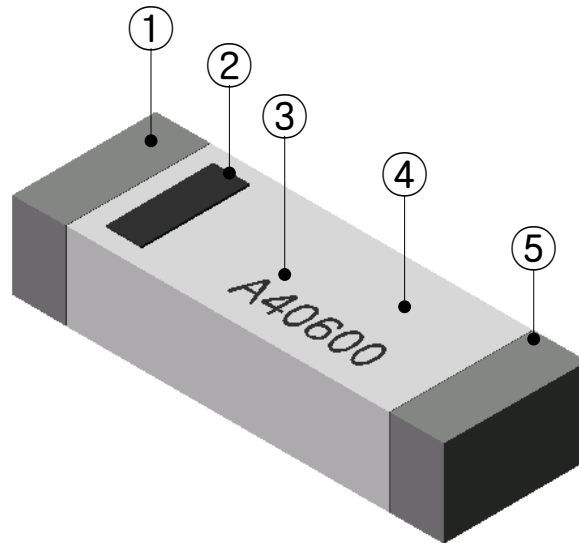

No	Part	Function	Material
1	External Electrode	Soldering, Feeding	Ag/Ni/Sn
2	Direction Index	Feeding Index	Ceramic
3	Ceramic Body	-	Ceramic
4	Text	Part No. Index	Ceramic
5	External Electrode	Soldering	Ag/Ni/Sn

6.2 Equivalent symbol

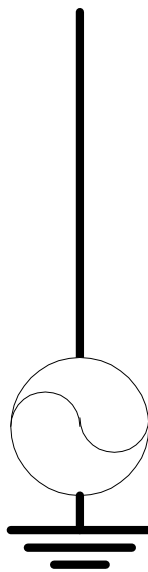

7. Cautions

- ① Storage environment must be at ambient temperature of 15~35°C and ambient humidity of 45~75 % RH. (MSL Level 2)
- ② Chip antenna can experience degradation of termination solder ability when subjected to high temperature of humidity, or if exposed to sulfur or chlorine gases.
- ③ Avoid mechanical shock (ex. falling) to the chip antenna to prevent mechanical cracking inside of the ceramic dielectric due to its own weight.

8. Packing Method

8.1 Carrier-tape

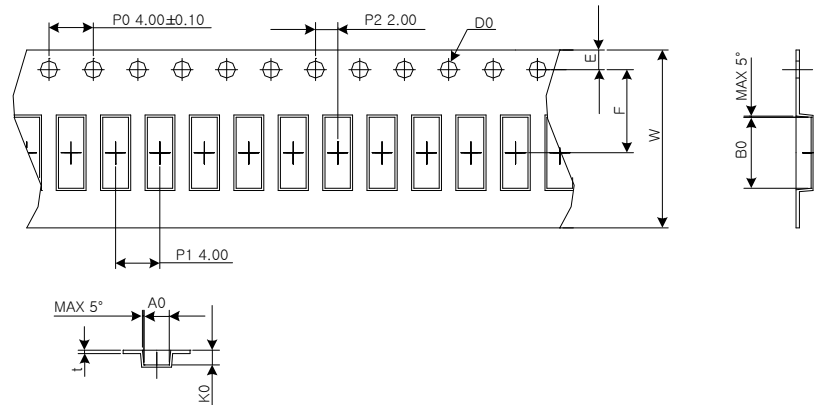

A0	2.30 ± 0.10	E	1.75 ± 0.10
B0	6.40 ± 0.10	F	7.50
K0	1.35 ± 0.10	t	0.30 ± 0.05
D0	1.55 ± 0.05	W	16.00 ± 0.30

8.2 Reel

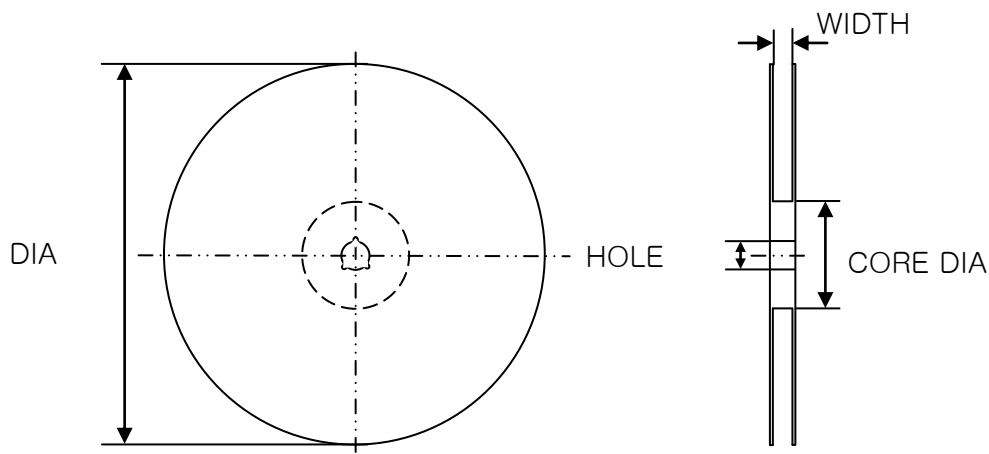

item	DIA	WIDTH	CORE DIA	HOLE
dimension(mm)	180.0 ± 0.3	17.0 ± 0.3	60.0 ± 1	13.0 ± 0.5

8.3 Packing box

8.3.1 Small box

Size : 183 (W) x 75 (D) x 185 (H) (mm)

Q'TY : 3 reel (2,000 ea/reel × 3 reel = 6,000 ea)



8.3.2 Middle box

Size : 365 (W) x 200 (D) x 200 (H) (mm)

Q'TY : 5 small box(6,000 ea/small box × 5 small box = 30,000 ea)

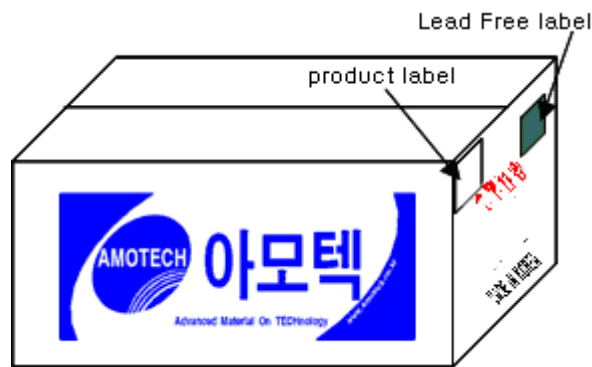

8.3.3 Large box

Size : 390 (W) x 390 (D) x 280 (H) (mm)

Q'TY : 14 small box(6,000 ea/ small box × 14 small box = 84,000 ea)

