

1. SET NAME ; RF RECEIVER

2. MODEL No ; MRF-250

3. SUMMARY

THIS PRODUCT IS A KIND OF RECEIVER THAT TRANSMIT DEMODULATED SIGNAL WITH IR LED AFTEN RECEIVING ELECTRONIC WAVE OF UHF SIGNAL(418KHz)

4. Electrical Characteristics

PARAMETER	UNIT	Min	Typ	Max	CONDITION&REMARK
Operating Voltage	V		9.0	12.0	User DC Adaptor
Operating Current	mA	8	10	12	Rms
Center Frequency	MHz	417.5	418.0	418.5	
IR LED Frequency	KHz	37	38	39	IR LED OUT

5. R/F MULTI RECEIVER BLOCK DIAGRAM & OPERATING SYSTEM

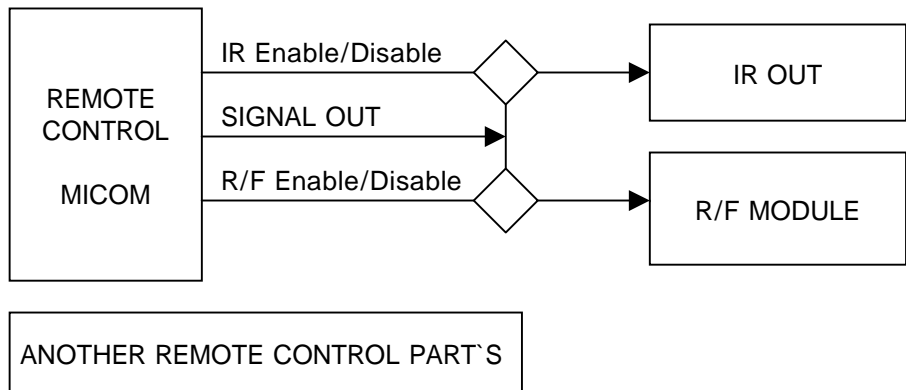

YOU CAN REMOTE CONTROL ACCORDING TO THE FOLLOWING TERMS TO ASSIGN R/F ENABLE/DISABLE PORT AND IR ENABLE/DISABLE

- 1)FIXING OF RF OUT(DEFAULT STATE)
> THE SIGNAL OUT GENERATE ID INFORMATION FIRST AND SIGNAL TO ENABLE "R/F E/D" PORT AND, TO DISABLE "IR E/D" PORT.
- 2)FIXING OF IR OUT
> THE SIGNAL OUT GENERATE SIGNAL ONLY TO DISABLE "R/F E/D" PORT AND, TO ENABLE "IR E/D" PORT.
- 3)FIXING BOTH RF AND IR
> THE SIGNAL OUT GENERATE ID INFORMATION FIRST AND SIGNAL TO CONNECT SIGNAL OUT LINE TO "IR MODULE" AND "RF MODULE" SIMULTANEOUSLY.
DEFAULT STATE IS ON STATE OF "IR OUT -BUILT IN" AND OFF STATE OF "IR OUT -1~6 BUILT OUT"

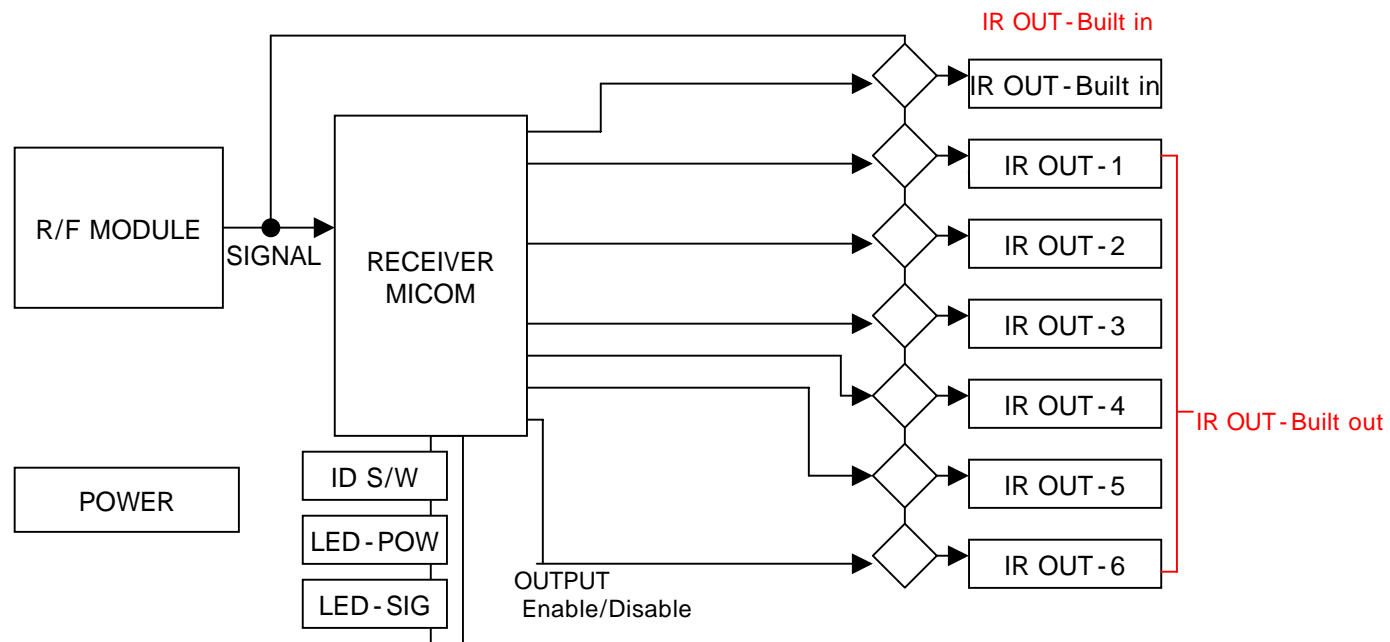

- 1) IN CASE OF (RECEIVED) ID IS THE SAME AS THE SET ID IN THE RECEIVER
 - > GENERATE THE SIGNAL TO SET ON APPOINTED IR OUT BETWEEN "IR OUT-BUILT IN" OR "IR OUT-1~6 BUILT OUT".
 - > TO BE SET ON WITH IN 10ms AT AVAILABLE ID AFTER READ ID

- 2) IN CASD OF (RECEIVED) ID IS DIFFERENT FROM THE SET ID IN THE RE RECEIVER.
 - > CUT THE SIGNAL TO OFF BETWEEN "OR OUT-BUILT IN" OR "IR OUT-1~6" BUILT OUT"
 - > BE ABLE TO SET ON/OFF APART IN "IR OUT-BUILT IN" OUTPUT