

FCC EVALUATION REPORT FOR CERTIFICATION

Applicant: OHSUNG ELECTRONICS CO., LTD.

Date of Issue: Dec. 14, 2016

#181 Gongdan-dong , Gumi-si, Gyeongbuk

Order Number: GETEC-C1-16-415

Republic of Korea.

Test Report Number: GETEC-E3-16-053

Attn : Mr. Hak-Ki Kim / General Manager

Test Site: GUMI UNIVERSITY EMC CENTER

FCC Registration Number: 269701

FCC ID. : OZ5URCDMSIN

Applicant : OHSUNG ELECTRONICS CO.,LTD.

Rule Part(s) : FCC Part 15 Subpart B
Equipment Class : Class B computing device peripheral (JBP)
EUT Type : Stream Injector Input Device
Type of Authority : Certification
Model Name : DMS-IN
Trade Name : UNIVERSAL remote control

This equipment has been shown to be in compliance with the applicable technical standards as indicated in the measurement report and was tested in accordance with the measurement procedures specified in ANSI C63.4 (2014) / Canadian standard ICES-003

I attest to the accuracy of data. All measurements reported herein were performed by me or were made under my supervision and are correct to the vest of my knowledge and belief. I assume full responsibility for the completeness of these measurements and vouch for the qualifications of all persons taking them.

Tested by,

Reviewed by,



Sang Hyun Park, Associate Engineer
GUMI UNIVERSITY EMC CENTER



Jae-Hoon Jeong, Technical Manager
GUMI UNIVERSITY EMC CENTER



CONTENTS

1. GENERAL INFORMATION	3
2. INTRODUCTION	4
3. PRODUCT INFORMATION	5
3.1 DESCRIPTION OF EUT.....	5
3.2 SUPPORT EQUIPMENT / CABLES USED	6
3.3 MODIFICATION ITEM(S).....	6
4. DESCRIPTION OF TESTS.....	7
4.1 TEST CONDITION.....	7
4.2 CONDUCTED EMISSION	8
4.3 RADIATED EMISSION.....	9
5. CONDUCTED EMISSION.....	10
5.1 OPERATING ENVIRONMENT	10
5.2 TEST SET-UP	10
5.3 MEASUREMENT UNCERTAINTY.....	10
5.4 LIMIT	11
5.5 TEST EQUIPMENT USED.....	11
5.6 TEST DATA FOR CONDUCTED EMISSION	11
6. RADIATED EMISSION	18
6.1 OPERATING ENVIRONMENT	18
6.2 TEST SET-UP	18
6.3 MEASUREMENT UNCERTAINTY.....	18
6.4 LIMIT	19
6.5 TEST EQUIPMENT USED.....	20
6.6 TEST DATA FOR RADIATED EMISSION.....	20
11. SAMPLE CALCULATIONS	33
11.1 EXAMPLE 1 :	33
11.2 EXAMPLE 2 :	33
12. RECOMMENDATION & CONCLUSION.....	34
APPENDIX A – ATESTSTATION STATEMENT	
APPENDIX B – ID SAMPLE LABEL & LOCATION	
APPENDIX C – BLOCK DIAGRAM	
APPENDIX D – TEST SET-UP PHOTOGRAPHS	
APPENDIX E – EXTERNAL PHOTOGRAPHS	
APPENDIX F – INTERNAL PHOTOGRAPHS	
APPENDIX G – USER’S MANUAL	



Scope: Measurement and determination of electromagnetic emissions (EME) of radio frequency devices including intentional and / or unintentional radiators for compliance with technical rules and regulations of the Federal Communications Commission.

1. General Information

Applicant: OHSUNG ELECTRONICS CO.,LTD.

Applicant Address: #181, Gongdan 1-dong, Gumi-si, Gyeongsangbuk-do, Republic of Korea

Manufacturer: OHSUNG ELECTRONICS CO.,LTD.

Manufacturer Address: #181, Gongdan 1-dong, Gumi-si, Gyeongsangbuk-do, Republic of Korea

Contact Person: Mr. Hak-Ki Kim / General Manager

Telephone Number: +82-54-468-7281 Fax Number: +82-54-461-8368

● FCC ID	OZ5URCDMSIN
● EUT Type	Stream Injector Input Device
● Equipment Class	Class B computing device peripheral (JBP)
● Model Name	DMS-IN
● Trade Name	UNIVERSAL remote control
● Serial Number	Prototype
● Rule Part(s)	FCC Part 15 Subpart B
● Type of Authority	Certification
● Test Procedure(s)	ANSI C63.4 (2014)
● Dates of Test	Nov. 22 ~ Dec.14, 2016
● Place of Test	GUMI UNIVERSITY EMC CENTER (FCC Test Firm Registration Number: 269701) 37 Yaeun-ro, Gumi-si, Gyeongsangbuk-do, 730-711, Republic of Korea.
● Test Report Number	GETEC-E3-16-053
● Date of Issue	Dec. 14, 2016

EUT Type: Stream Injector Input Device

FCC ID.: OZ5URCDMSIN





2. Introduction

The measurement procedure described in American National Standard for Methods of Measurement of Radio-Nose Emissions From Low-Voltage Electrical and Electronic Equipment in the Range of 9 kHz to 40 GHz (ANSI C63.4-2014) was used in determining radiated and conducted emissions emanating from **OHSUNG ELECTRONICS CO.,LTD. Stream Injector Input Device (Model Name: DMS-IN)**

These measurement tests were conducted at **GUMI UNIVERSITY EMC CENTER**

The site address is 37 Yaeun-ro, Gumi-si, Gyeongsangbuk-do, 730-711, Republic of Korea.

This test site is one of the highest point of Gumi UNIVERSITY at about 200 km away from Seoul city and 40 km away from Daegu city. It is located in the valley surrounded by mountains in all directions where ambient radio signal conditions are quiet and a favorable area to measure the radio frequency interference on open field test site for the computing and ISM devices manufactures. The detailed description of the measurement facility was found to be in compliance with the requirements of §2.948 according to ANSI C63.4 (2014)

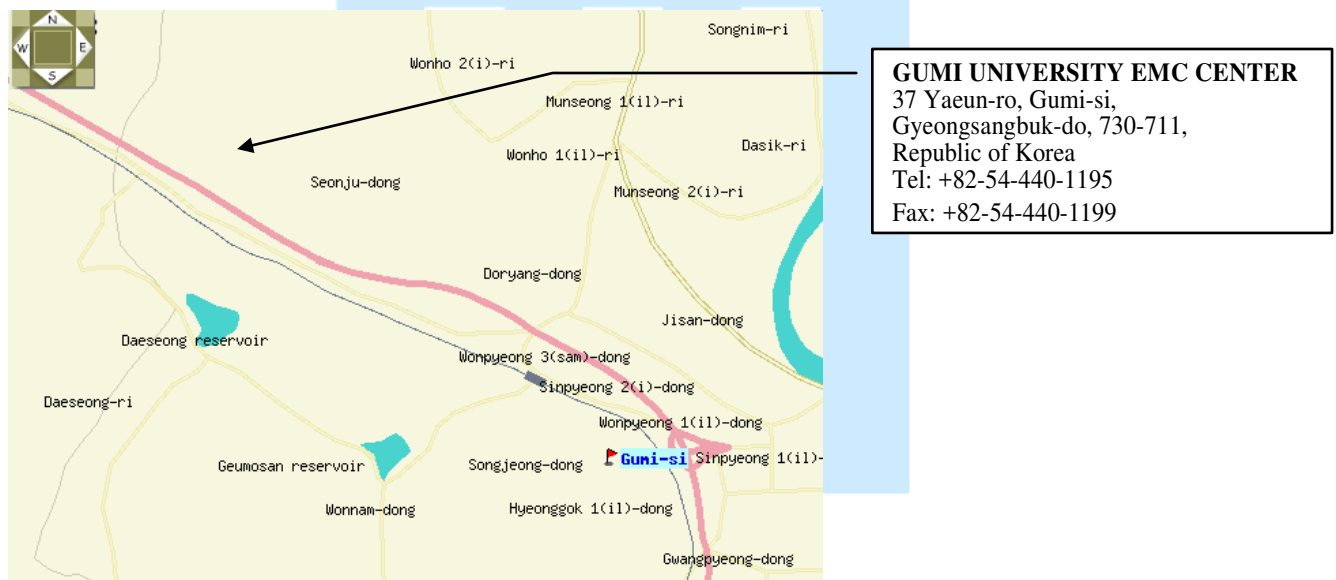

Fig 1. The map above shows the Gumi UNIVERSITY in vicinity area.



3. Product Information

3.1 Description of EUT

The Equipment under Test (EUT) is the **OHSUNG Electronics Co.,Ltd.**
Stream Injector Input Device (Model Name: DMS-IN) FCC ID.: OZ5URCDMSIN

Type of product	Stream Injector Input Device
Model Name	DMS-IN
Power	DC 5V(Standard PoE Injector or PoE Switch(purchased separately)
Microprocessor	Coretex-A5 600MHz
Memory	128 MB NAND, 128 MB RAM
Network	One 10/100 Ethernet port (PoE)
Weight	5.8 oz
Size	4.6" x 4.6" x 1.2"



3.2 Support Equipment / Cables used

3.2.1 Used Support Equipment

Description	Manufacturer	Model Name	S/N & FCC ID.
Stream Injector Output Device	OHSUNG ELECTRONICS CO.,LTD.	DMS-OUT	S/N: None FCC ID.: OZ5URCDMSOUT
TP-Link network	TP-LINK Technologies Co., Ltd	TL-SG1008P	S/N: None FCC ID.: None
Wireless router	EFM networks	N8004	S/N: N8004 11062501912 FCC ID.: Verification
DVD Player	LG Electronics inc	LC-954	S/N: None FCC ID.: Verification

See “Appendix D – Test Setup Photographs” for actual system test set-up

3.2.2 System configuration

Description	Manufacturer	Model Name	S/N & FCC ID.
AC-DC Adapter ¹⁾	Dongguan MLF Tech Co., Ltd	MLF-A250501000CU	-

1) Input: 100 – 240V , 50/60Hz 0.4A ; Output 5 V, 1A

3.2.3 Used Cable(s)

Cable Name	Condition	Description
LAN cable	Connected to the EUT and Network	10.00 m shielded
Multi tap	Connected to the AC Adapter and AC Power Source	1.80 m Unshielded
AC-DC adapter	Connected to the EUT and Multi tap	1.80 m shielded
Analog audio	Connected to the EUT and DVD Player	3.00 m shielded
Digital audio	Connected to the EUT and DVD Player	3.00 m shielded
Optical audio	Connected to the EUT and DVD Player	3.00 m Unshielded

3.3 Modification Item(s)

- None



4. Description of tests

4.1 Test Condition

The EUT was installed, arranged and operated in a manner that is most representative of equipment as typically used. The measurements were carried out while varying operating modes and cable positions within typically arrangement to determine maximum emission level.

The test conditions of the noted test mode(s) in this test report are;

- Test Voltage / Frequency : AC 120 V / 60 Hz
- Test Mode(s)
 - . Network communication
- Operating test pattern
 - . Conducted Emission: The EUT was communication via LAN port to Network
 - . Radiated Emission: The EUT was communication via LAN port to Network

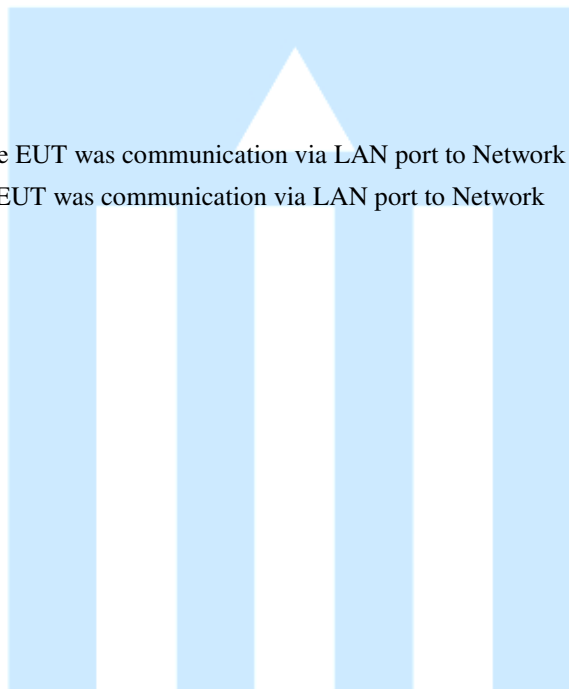



4.2 Conducted Emission

The Line conducted emission test facility is inside a 4 m × 8 m × 2.5 m shielded enclosure.
(FCC Test Film Registration No.: 269701)

The EUT was placed on a non-conducting 1.0 m by 1.5 m table, which is 0.4 m in height and 0.8 m away from the vertical wall of the shielded enclosure.

The EUT is powered from the Rohde & Schwarz LISN (ENV216) and the support equipment is powered from the Rohde & Schwarz LISN (ENV216). Powers to the LISN are filtered by high-current high insertion loss power line filter.

Sufficient time for EUT, support equipment, and test equipment was allowed in order for them to warm up to their normal operating condition.

The RF output of the LISN was connected to the EMI test receiver (Rohde & Schwarz, ESCI).

Exploratory measurements were conducted to identify the highest emission by operating the EUT in a range of typical modes of operation, cable positions, system configuration and arrangement.

Based on exploratory measurements, the final measurements were conducted at the worst test conditions.

Exploratory measurements were scanned using Peak mode of EMI Test receiver from 150 kHz to 30 MHz with 20 ms sweep time. The final measurements were measured with Quasi-Peak and Average mode.

The bandwidth of EMI Test Receiver was set to 9 kHz. Interface cables were connected to the available interface ports of the test unit. Excess cable lengths were bundled at center with 30 cm ~ 40 cm.

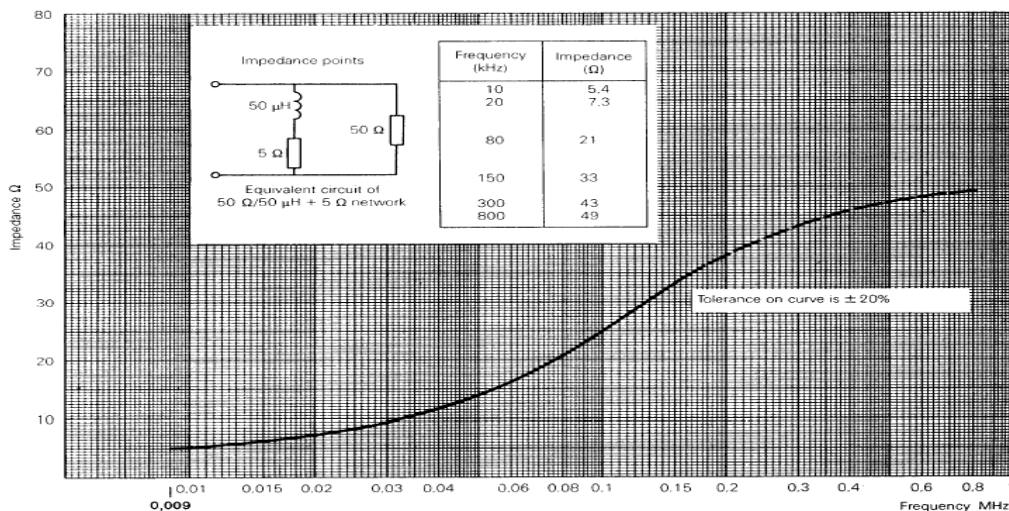

Fig 2. Impedance of LISN



4.3 Radiated Emission

Exploratory Radiated measurements were conducted at the 3 m or 10 m semi anechoic chamber in order to identify the highest emission by operating the EUT in a range of typical modes of operation, cable positions, system configuration and arrangement.

Based on exploratory measurements, the final measurements were conducted at the worst test conditions.

Final measurements of below 1 GHz were made at 3 m or 10 m Chamber (FCC Test Firm Registration No.: 269701) or Open area test site (FCC Test Firm Registration No.: 269701) that complies with CISPR 16/ANSI C63.4.

Above 1 GHz final measurements were conducted at the 3m Chamber (FCC Test Firm Registration No.: 269701) only.

For measurements above 1GHz, the bottom side of 3 m chamber was installed with absorbers in order to meet SVSWR Limit.

Exploratory measurements were scanned using Peak mode of EMI Test receiver and final measurements were measured with Quasi-Peak mode (Below 1 GHz) and Peak & Average mode (Above 1 GHz).

The measurements were performed by rotating the EUT 360° and adjusting the receive antenna height from 1.0 m to 4.0 m. All frequencies were investigated in both horizontal and vertical antenna polarity.

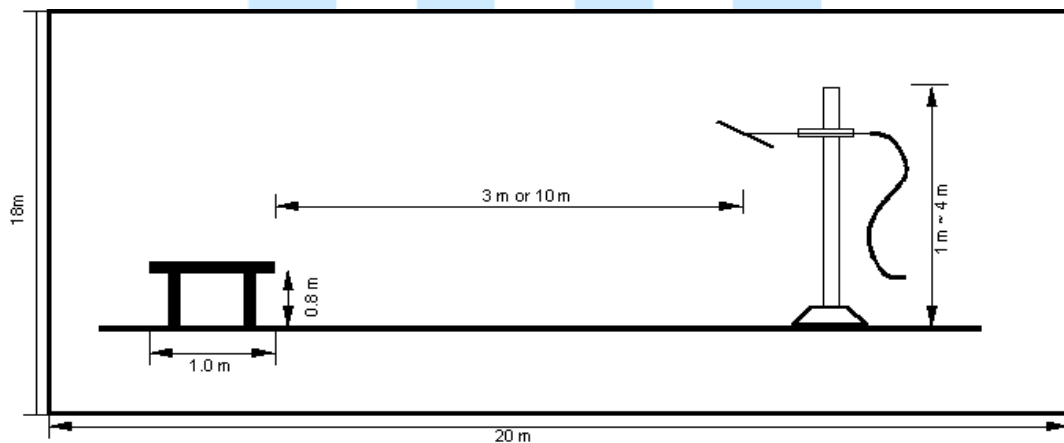

Fig 3. Dimensions of test site (Below 1 GHz)

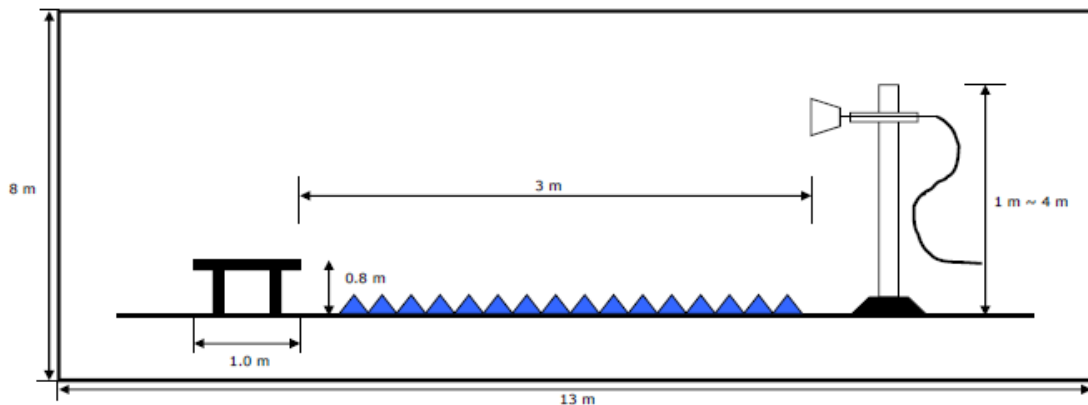

Fig 4. Dimensions of test site (Above 1 GHz)



5. Conducted Emission

5.1 Operating Environment

Temperature : 23.5 °C
Relative Humidity : 40.4 % R.H.

5.2 Test Set-up

The conducted emission measurements were performed in the shielded room.

The EUT was placed on wooden table, 0.4 m heights above the floor, 0.8 m from the reference ground plane (GRP) wall and 0.8 m from AMN & ISN.

AMN is bonded on horizontal reference ground plane.

The ground plane, which was electrically bonded to the shield room, ground system and all power lines entering the shield room, were filtered.

5.3 Measurement Uncertainty

The measurement uncertainty was calculated in accordance with ISO "Guide to the expression of uncertainty in measurement."

The measurement uncertainty was given with a confidence of 95 %.

Test Items	Uncertainty	Remark
Conducted emission (9 kHz ~ 150 kHz)	3.85 dB	Confidence level of approximately 95 % ($k = 2$)
Conducted emission (150 kHz ~ 30 MHz)	3.32 dB	Confidence level of approximately 95 % ($k = 2$)

Where relevant, the following measurement uncertainty levels have been estimated for tests performed on the EUT as specified in CISPR 16-4-2.

The listed uncertainties are the worst case uncertainty for the entire range of measurement. please note that the uncertainty values are provided for informational purposes only are not used in determining the PASS/FAIL results



5.4 Limit

RFI Conducted	FCC Limit(dB μ V) Class B	
Freq. Range	Quasi-Peak	Average
150 kHz ~ 0.5 MHz	66 ~ 56*	56 ~ 46*
0.5 MHz ~ 5 MHz	56	46
5 MHz ~ 30 MHz	60	50

*Limits decreases linearly with the logarithm of frequency.

5.5 Test Equipment used

Model Name	Manufacturer	Description	Serial Number	Due to Calibration
■ - ESCI	Rohde & Schwarz	EMI Test Receiver	100237	Apr. 18, 2017
■ - ENV216	Rohde & Schwarz	LISN	100172	Apr. 19, 2017
■ - ENV216	Rohde & Schwarz	LISN	100173	Apr. 19, 2017
□ - ISN T8	TESEQ.GmbH	ISN	24568	Apr. 22, 2017
□ - ST 08	TESEQ.GmbH	ISN	42870	Jun. 09, 2017
■ - EMC 32	Rohde & Schwarz	Software	Ver 8.53	N/A

5.6 Test data for Conducted Emission

- Test Date : Nov. 29~30, 2016
- Resolution Bandwidth : 9 kHz
- Frequency Range : 0.15 MHz ~ 30 MHz
- Line : L1: Live, N: Neutral



Operating condition: Network Communication mode (Digital input & PoE Injector)

Red(♦) marker: Quasi Peak detector ; Green(♦) marker: Average detector

Blue line: Peak value ; Green line: Average value

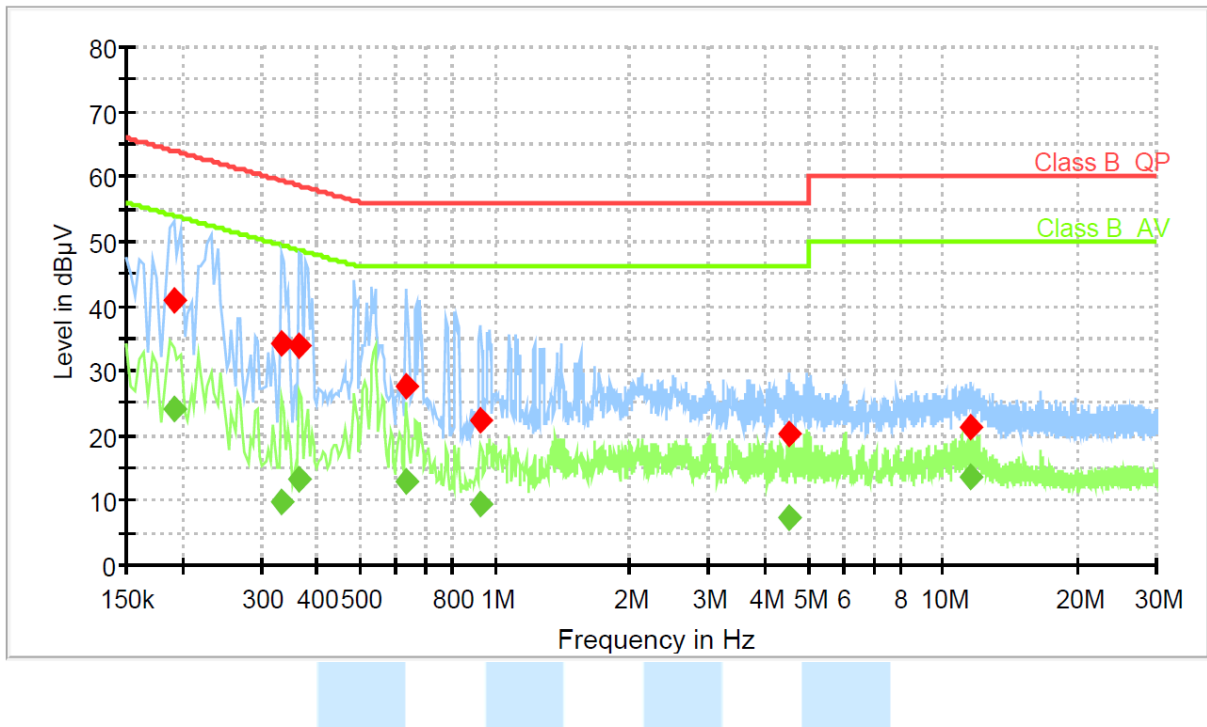

Final Result 1

Frequency (MHz)	QuasiPeak (dBµV)	Meas. Time (ms)	Bandwidth (kHz)	Filter	Line	Corr. (dB)	Margin (dB)	Limit (dBµV)	Comment
0.191044	40.7	100.0	9.000	Off	N	9.6	23.3	64.0	
0.332831	34.2	100.0	9.000	Off	N	9.7	25.2	59.4	
0.366413	34.0	100.0	9.000	Off	N	9.7	24.6	58.6	
0.631331	27.7	100.0	9.000	Off	L1	9.7	28.3	56.0	
0.926100	22.5	100.0	9.000	Off	L1	9.7	33.5	56.0	
4.523025	20.2	100.0	9.000	Off	L1	9.8	35.8	56.0	
11.537775	21.3	100.0	9.000	Off	L1	9.9	38.7	60.0	

Final Result 2

Frequency (MHz)	CAverage (dBµV)	Meas. Time (ms)	Bandwidth (kHz)	Filter	Line	Corr. (dB)	Margin (dB)	Limit (dBµV)	Comment
0.191044	24.2	100.0	9.000	Off	N	9.6	29.8	54.0	
0.332831	9.7	100.0	9.000	Off	N	9.7	39.7	49.4	
0.366413	13.4	100.0	9.000	Off	N	9.7	35.2	48.6	
0.631331	13.1	100.0	9.000	Off	L1	9.7	32.9	46.0	
0.926100	9.4	100.0	9.000	Off	L1	9.7	36.6	46.0	
4.523025	7.5	100.0	9.000	Off	L1	9.8	38.5	46.0	
11.537775	13.8	100.0	9.000	Off	L1	9.9	36.2	50.0	

< Fig 5. Graph of continuous disturbance >



Operating condition: Network Communication mode (Digital input & AC-DC Adapter)

Red(♦) marker: Quasi Peak detector ; Green(♦) marker: Average detector

Blue line: Peak value ; Green line: Average value

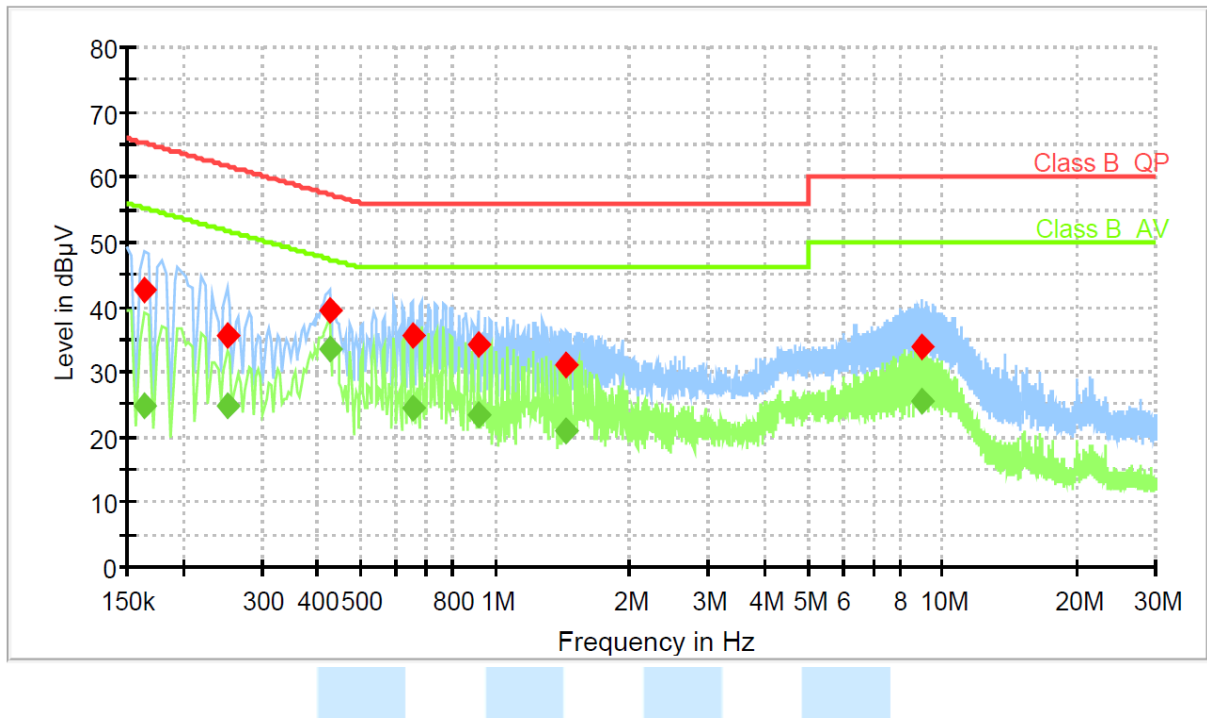

Final Result 1

Frequency (MHz)	QuasiPeak (dBµV)	Meas. Time (ms)	Bandwidth (kHz)	Filter	Line	Corr. (dB)	Margin (dB)	Limit (dBµV)	Comment
0.164925	42.6	100.0	9.000	Off	N	9.6	22.6	65.2	
0.250744	35.7	100.0	9.000	Off	L1	9.6	26.0	61.7	
0.426113	39.5	100.0	9.000	Off	L1	9.6	17.8	57.3	
0.653719	35.5	100.0	9.000	Off	L1	9.7	20.5	56.0	
0.914906	34.1	100.0	9.000	Off	L1	9.7	21.9	56.0	
1.444744	31.1	100.0	9.000	Off	L1	9.7	24.9	56.0	
9.000525	33.7	100.0	9.000	Off	L1	9.9	26.3	60.0	

Final Result 2

Frequency (MHz)	CAverage (dBµV)	Meas. Time (ms)	Bandwidth (kHz)	Filter	Line	Corr. (dB)	Margin (dB)	Limit (dBµV)	Comment
0.164925	24.7	100.0	9.000	Off	N	9.6	30.5	55.2	
0.250744	24.7	100.0	9.000	Off	L1	9.6	27.1	51.7	
0.426113	33.4	100.0	9.000	Off	L1	9.6	13.9	47.3	
0.653719	24.5	100.0	9.000	Off	L1	9.7	21.5	46.0	
0.914906	23.2	100.0	9.000	Off	L1	9.7	22.8	46.0	
1.444744	21.0	100.0	9.000	Off	L1	9.7	25.0	46.0	
9.000525	25.5	100.0	9.000	Off	L1	9.9	24.5	50.0	

< Fig 6. Graph of continuous disturbance >



- Operating condition: Network Communication mode (Analog input & PoE Injector)
- Red(♦) marker: Quasi Peak detector ; Green(◆) marker: Average detector
- Blue line: Peak value ; Green line: Average value

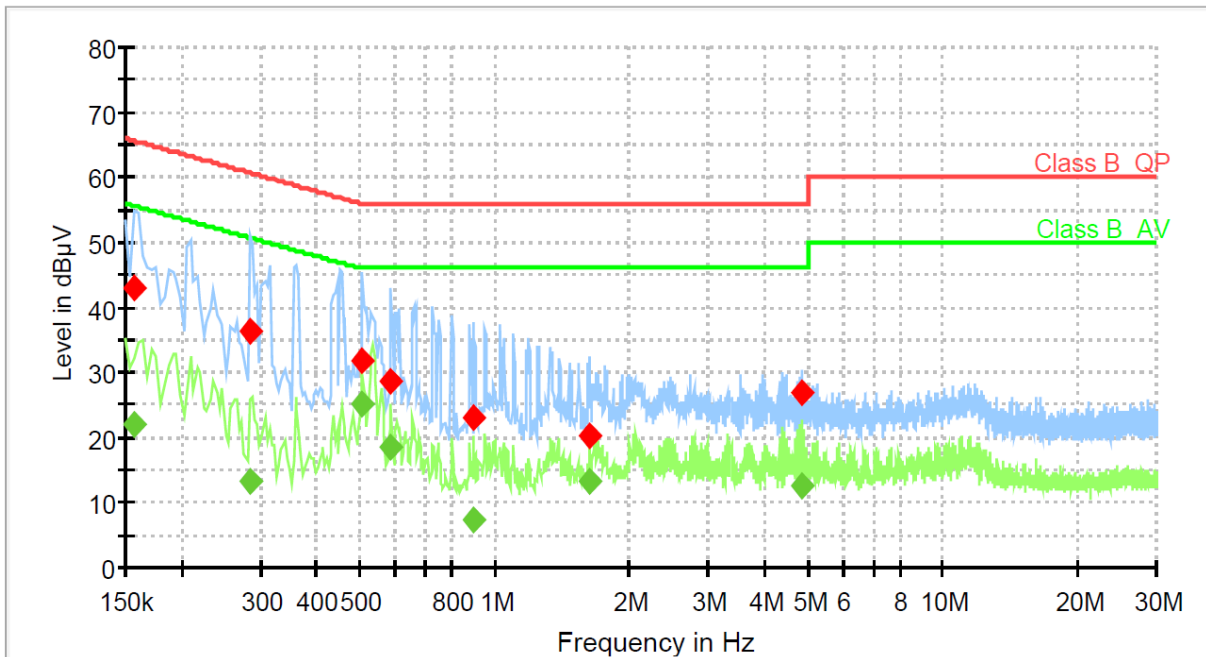

Final Result 1

Frequency (MHz)	QuasiPeak (dBµV)	Meas. Time (ms)	Bandwidth (kHz)	Filter	Line	Corr. (dB)	Margin (dB)	Limit (dBµV)	Comment
0.157463	43.0	100.0	9.000	Off	N	9.6	22.6	65.6	
0.284325	36.4	100.0	9.000	Off	N	9.6	24.3	60.7	
0.508200	31.7	100.0	9.000	Off	L1	9.6	24.3	56.0	
0.586556	28.6	100.0	9.000	Off	N	9.7	27.4	56.0	
0.896250	22.9	100.0	9.000	Off	N	9.7	33.1	56.0	
1.631306	20.3	100.0	9.000	Off	N	9.7	35.7	56.0	
4.828988	26.9	100.0	9.000	Off	L1	9.8	29.1	56.0	

Final Result 2

Frequency (MHz)	CAverage (dBµV)	Meas. Time (ms)	Bandwidth (kHz)	Filter	Line	Corr. (dB)	Margin (dB)	Limit (dBµV)	Comment
0.157463	22.2	100.0	9.000	Off	N	9.6	33.4	55.6	
0.284325	13.4	100.0	9.000	Off	N	9.6	37.3	50.7	
0.508200	25.1	100.0	9.000	Off	L1	9.6	20.9	46.0	
0.586556	18.7	100.0	9.000	Off	N	9.7	27.3	46.0	
0.896250	7.4	100.0	9.000	Off	N	9.7	38.6	46.0	
1.631306	13.3	100.0	9.000	Off	N	9.7	32.7	46.0	
4.828988	12.7	100.0	9.000	Off	L1	9.8	33.3	46.0	

< Fig 7. Graph of continuous disturbance >



Operating condition: Network Communication mode (Analog input & AC-DC Adapter)

Red(♦) marker: Quasi Peak detector ; Green(◆) marker: Average detector

Blue line: Peak value ; Green line: Average value

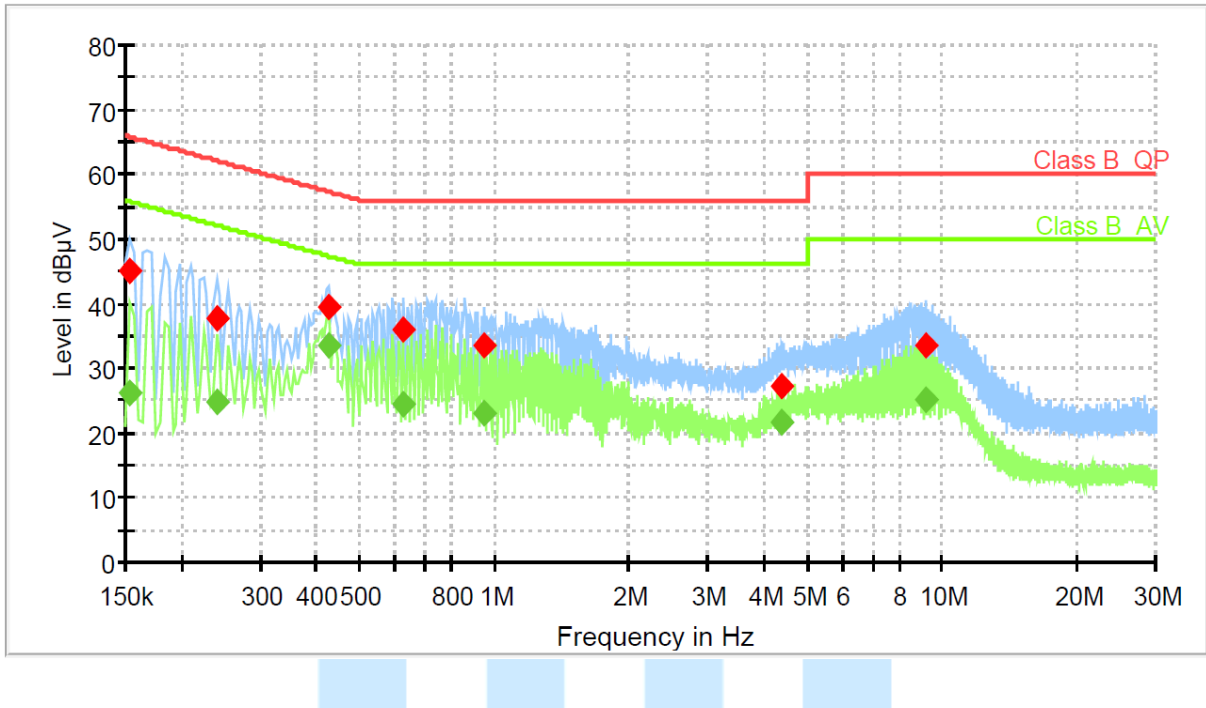

Final Result 1

Frequency (MHz)	QuasiPeak (dBµV)	Meas. Time (ms)	Bandwidth (kHz)	Filter	Line	Corr. (dB)	Margin (dB)	Limit (dBµV)	Comment
0.153731	45.2	100.0	9.000	Off	N	9.6	20.6	65.8	
0.239550	37.8	100.0	9.000	Off	L1	9.6	24.3	62.1	
0.426113	39.4	100.0	9.000	Off	L1	9.6	17.9	57.3	
0.627600	35.9	100.0	9.000	Off	L1	9.7	20.1	56.0	
0.952219	33.6	100.0	9.000	Off	L1	9.7	22.4	56.0	
4.388700	27.4	100.0	9.000	Off	L1	9.8	28.6	56.0	
9.183356	33.6	100.0	9.000	Off	L1	9.9	26.4	60.0	

Final Result 2

Frequency (MHz)	CAverage (dBµV)	Meas. Time (ms)	Bandwidth (kHz)	Filter	Line	Corr. (dB)	Margin (dB)	Limit (dBµV)	Comment
0.153731	26.1	100.0	9.000	Off	N	9.6	29.7	55.8	
0.239550	25.0	100.0	9.000	Off	L1	9.6	27.1	52.1	
0.426113	33.5	100.0	9.000	Off	L1	9.6	13.8	47.3	
0.627600	24.3	100.0	9.000	Off	L1	9.7	21.7	46.0	
0.952219	22.9	100.0	9.000	Off	L1	9.7	23.1	46.0	
4.388700	21.5	100.0	9.000	Off	L1	9.8	24.5	46.0	
9.183356	25.3	100.0	9.000	Off	L1	9.9	24.7	50.0	

< Fig 8. Graph of continuous disturbance >



- Operating condition: Network Communication mode (Optical input & PoE Injector)
- Red(♦) marker: Quasi Peak detector ; Green(♦) marker: Average detector
- Blue line: Peak value ; Green line: Average value

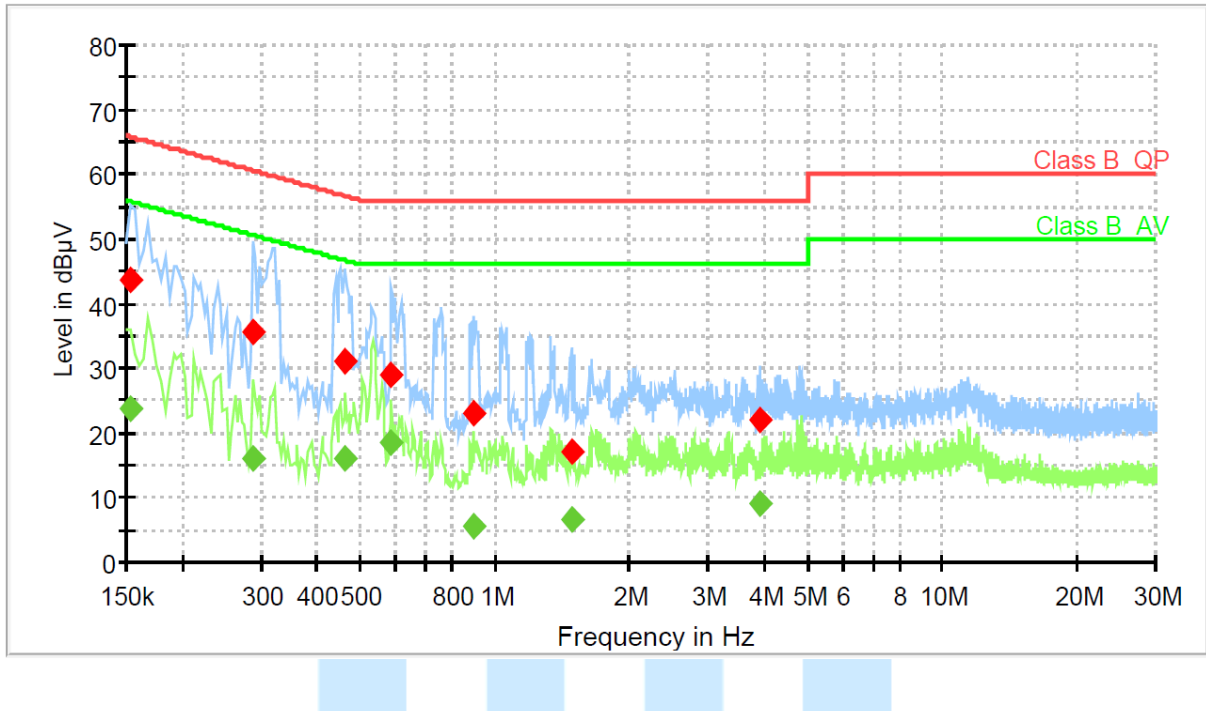

Final Result 1

Frequency (MHz)	QuasiPeak (dBµV)	Meas. Time (ms)	Bandwidth (kHz)	Filter	Line	Corr. (dB)	Margin (dB)	Limit (dBµV)	Comment
0.153731	43.6	100.0	9.000	Off	N	9.6	22.2	65.8	
0.288056	35.5	100.0	9.000	Off	N	9.6	25.1	60.6	
0.459694	31.0	100.0	9.000	Off	N	9.7	25.7	56.7	
0.586556	28.9	100.0	9.000	Off	N	9.7	27.1	56.0	
0.892519	23.2	100.0	9.000	Off	N	9.7	32.8	56.0	
1.482056	17.2	100.0	9.000	Off	L1	9.7	38.8	56.0	
3.926025	22.0	100.0	9.000	Off	L1	9.8	34.0	56.0	

Final Result 2

Frequency (MHz)	CAverage (dBµV)	Meas. Time (ms)	Bandwidth (kHz)	Filter	Line	Corr. (dB)	Margin (dB)	Limit (dBµV)	Comment
0.153731	23.9	100.0	9.000	Off	N	9.6	31.9	55.8	
0.288056	16.0	100.0	9.000	Off	N	9.6	34.6	50.6	
0.459694	16.2	100.0	9.000	Off	N	9.7	30.5	46.7	
0.586556	18.6	100.0	9.000	Off	N	9.7	27.4	46.0	
0.892519	5.7	100.0	9.000	Off	N	9.7	40.3	46.0	
1.482056	6.8	100.0	9.000	Off	L1	9.7	39.2	46.0	
3.926025	9.0	100.0	9.000	Off	L1	9.8	37.0	46.0	

< Fig 9. Graph of continuous disturbance >



Operating condition: Network Communication mode (Optical input & AC-DC Adapter)

Red(♦) marker: Quasi Peak detector ; Green(◆) marker: Average detector

Blue line: Peak value ; Green line: Average value

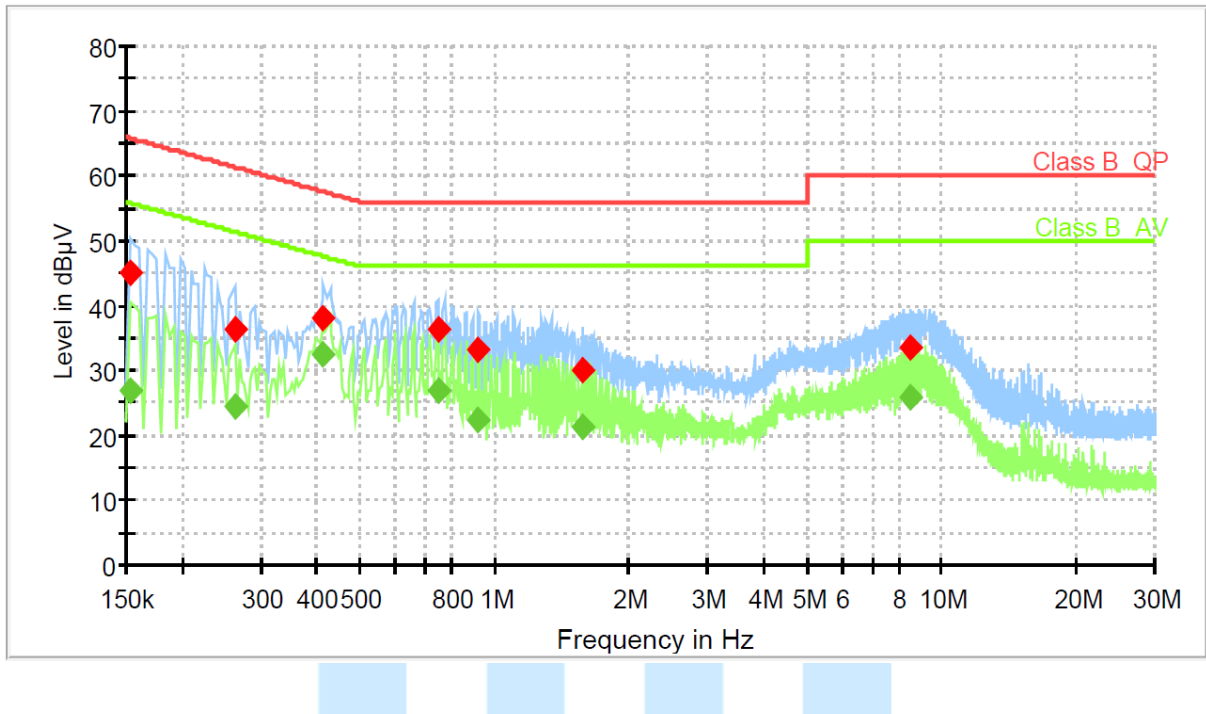

Final Result 1

Frequency (MHz)	QuasiPeak (dBµV)	Meas. Time (ms)	Bandwidth (kHz)	Filter	Line	Corr. (dB)	Margin (dB)	Limit (dBµV)	Comment
0.153731	45.2	100.0	9.000	Off	N	9.6	20.6	65.8	
0.261938	36.4	100.0	9.000	Off	L1	9.6	25.0	61.4	
0.414919	38.0	100.0	9.000	Off	L1	9.6	19.6	57.5	
0.747000	36.3	100.0	9.000	Off	L1	9.7	19.7	56.0	
0.922369	33.3	100.0	9.000	Off	L1	9.7	22.7	56.0	
1.571606	30.2	100.0	9.000	Off	L1	9.7	25.8	56.0	
8.519194	33.7	100.0	9.000	Off	L1	9.9	26.3	60.0	

Final Result 2

Frequency (MHz)	CAverage (dBµV)	Meas. Time (ms)	Bandwidth (kHz)	Filter	Line	Corr. (dB)	Margin (dB)	Limit (dBµV)	Comment
0.153731	26.7	100.0	9.000	Off	N	9.6	29.1	55.8	
0.261938	24.6	100.0	9.000	Off	L1	9.6	26.8	51.4	
0.414919	32.5	100.0	9.000	Off	L1	9.6	15.0	47.5	
0.747000	27.0	100.0	9.000	Off	L1	9.7	19.0	46.0	
0.922369	22.5	100.0	9.000	Off	L1	9.7	23.5	46.0	
1.571606	21.3	100.0	9.000	Off	L1	9.7	24.7	46.0	
8.519194	25.7	100.0	9.000	Off	L1	9.9	24.3	50.0	

< Fig 10. Graph of continuous disturbance >



6. Radiated Emission

6.1 Operating Environment

Temperature : 22.9 °C
 Relative Humidity : 42.0 % R.H.

6.2 Test Set-up

A preliminary and final measurement was at 3 m & 10 m anechoic chamber.

The EUT was placed on a non-conductive turntable approximately 1.0 m above the ground plane.

The turntable with EUT was rotated 360°, and the antenna was varied in height between 1.0 m and 4.0 m in order to determine the maximum emission levels.

This procedure was performed for both horizontal and vertical polarization of the receiving antenna.

6.3 Measurement Uncertainty

The measurement uncertainty was calculated in accordance with ISO “Guide to the expression of uncertainty in measurement”.

Test Items(3 m Anechoic Chamber)	Uncertainty	Remark
Radiated emission (30 MHz ~ 300 MHz, 3 m, Vertical)	4.78 dB	Confidence level of approximately 95 % ($k = 2$)
Radiated emission (30 MHz ~ 300 MHz, 3 m, Horizontal)	4.77 dB	Confidence level of approximately 95 % ($k = 2$)
Radiated emission (300 MHz ~ 1 000 MHz, 3 m, Vertical)	5.06 dB	Confidence level of approximately 95 % ($k = 2$)
Radiated emission (300 MHz ~ 1 000 MHz, 3 m, Horizontal)	5.03 dB	Confidence level of approximately 95 % ($k = 2$)
Radiated emission (1 000 MHz ~ 6 000 MHz, 3 m)	5.42 dB	Confidence level of approximately 95 % ($k = 2$)
Radiated emission (1 000 MHz ~ 18 000 MHz, 3 m)	5.64 dB	Confidence level of approximately 95 % ($k = 2$)
Test Items(10 m Anechoic Chamber)	Uncertainty	Remark
Radiated emission (30 MHz ~ 300 MHz, 3 m, Vertical)	4.36 dB	Confidence level of approximately 95 % ($k = 2$)
Radiated emission (30 MHz ~ 300 MHz, 3 m, Horizontal)	4.37 dB	Confidence level of approximately 95 % ($k = 2$)
Radiated emission (300 MHz ~ 1 000 MHz, 3 m, Vertical)	4.49 dB	Confidence level of approximately 95 % ($k = 2$)
Radiated emission (300 MHz ~ 1 000 MHz, 3 m, Horizontal)	4.47 dB	Confidence level of approximately 95 % ($k = 2$)
Radiated emission (1 000 MHz ~ 6 000 MHz, 3 m)	5.27 dB	Confidence level of approximately 95 % ($k = 2$)

Where relevant, the following measurement uncertainty levels have been estimated for tests performed on the EUT as specified in CISPR 16-4-2.

The listed uncertainties are the worst case uncertainty for the entire range of measurement. please note that the uncertainty values are provided for informational purposes only are not used in determining the PASS/FAIL results

EUT Type: Stream Injector Input Device

FCC ID.: OZ5URCDMSIN





6.4 Limit

Frequency (MHz)	FCC Limit @ 3 m. dB μ V/m	CISPR Limit @ 10 m. dB μ V/m
30 ~ 88	40.0	30.0
88 ~ 216	43.5	30.0
216 ~ 230	46.0	30.0
230 ~ 960	46.0	37.0
960 ~ 1 000	54.0	37.0

Frequency (MHz)	FCC Class B Peak Limit @ 3 m dB μ V/m	FCC Class B Average Limit@ 3 m dB μ V/m
> 1 000	74.0	54.0

Frequency (MHz)	CISPR Class B Peak Limit @ 3 m dB μ V/m	CISPR Class B Average Limit@ 3 m dB μ V/m
> 1 000	70.0	50.0



6.5 Test Equipment used

Model Name	Manufacturer	Description	Serial Number	Due to Calibration
<input type="checkbox"/> - ESIB26	Rohde & Schwarz	EMI Test Receiver	830482/010	Apr. 18, 2017
■ - ESU40	Rohde & Schwarz	EMI Test Receiver	100266	Jul. 20, 2017
■ - ESR7	Rohde & Schwarz	EMI Test Receiver	101382	Apr. 18, 2017
■ - VULB9160	Schwarzbeck	Broad Band Test Antenna	3193	Mar. 28, 2018
■ - BBHA9120D	Schwarzbeck	Horn ANT	207	Oct. 13, 2017
■ - MCU066	maturu GmbH	Position Controller	1390306	N/A
■ - TT2.5SI	maturu GmbH	Turntable	1390307	N/A
■ - AM 4.0	maturu GmbH	Antenna Mast	1390308	N/A
■ - CO3000	Innco system GmbH	Position Controller	1390306	N/A
■ - DT3000	Innco system GmbH	Turntable	1390307	N/A
■ - MA4000-EP	Innco system GmbH	Antenna Mast	1390308	N/A
<input type="checkbox"/> - MA4640-XP-ET	Innco system GmbH	Antenna Mast	MA4640/558	N/A
■ - AFS 44 00101800-25-10P-44	MITEQ	Preamplifier	1258943	Jan. 05,2017
■ - 87405A	Agilent	Preamplifier	MY39500777	Jan. 05,2017
■ - EMC 32	Rohde & Schwarz	Software	Ver.9.26.01	N/A

6.6 Test data for Radiated Emission

- Test Date : Nov 22~Dec. 14 ,2016
- Measurement Distance : 3 m, 10 m
- Note : The highest frequency of the internal source of the EUT is between 500 MHz and 1 000 MHz(600 MHz). The measurement was made up to 5 000 MHz.

- Measurement

Frequency range	30 MHz ~ 1 GHz	Above 1 GHz
Detector mode	Quasi peak	Peak / Average
Resolution bandwidth	120 kHz	1 MHz



- 30 MHz ~ 1 GHz

- Operating condition: Network Communication mode(Digital input & PoE Injector)
- Black(◆) marker: Quasi Peak detector;
- Pink line: Peak value of vertical polarization ; Blue line: Peak value of Horizontal polarization

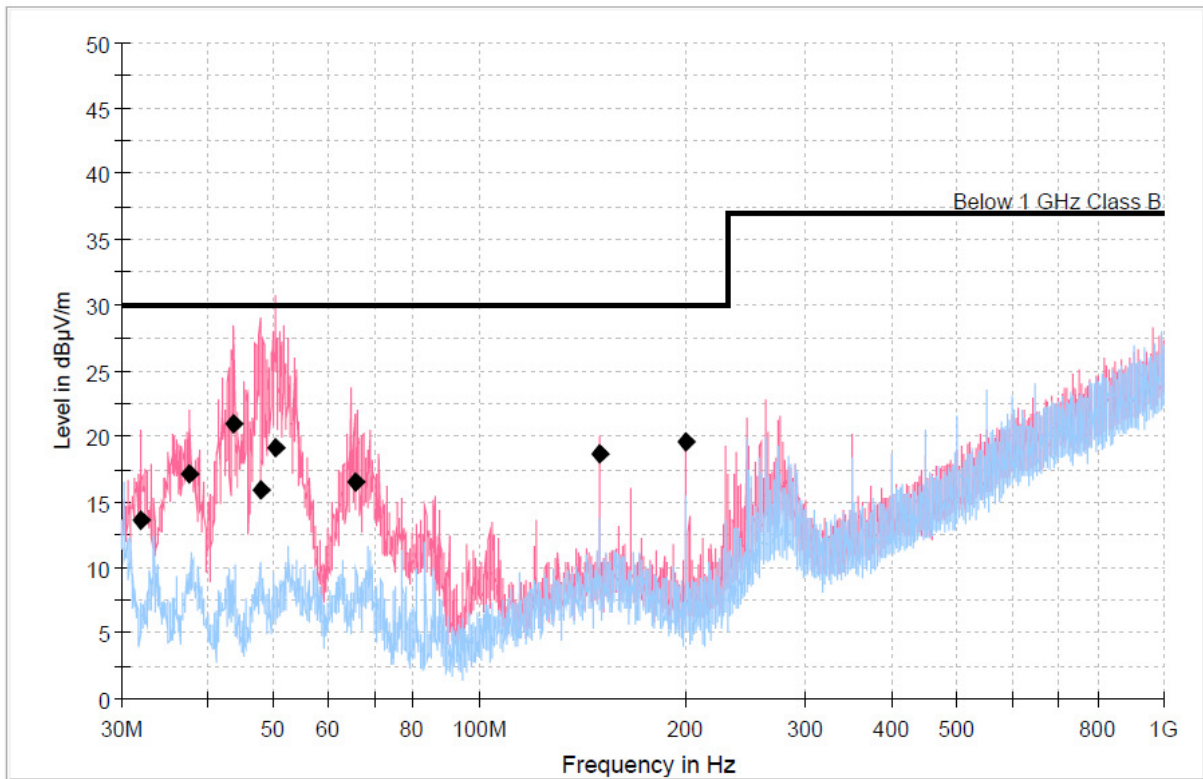

Final Result

Frequency (MHz)	QuasiPeak (dBµV/m)	Limit (dBµV/m)	Margin (dB)	Meas. Time (ms)	Bandwidth (kHz)	Height (cm)	Pol	Azimuth (deg)	Corr. (dB)
32.015	13.56	30.00	16.44	10000.0	120.000	105.4	V	332.0	-13.1
37.593	17.08	30.00	12.92	10000.0	120.000	104.6	V	340.0	-12.5
43.765	20.97	30.00	9.03	10000.0	120.000	109.4	V	315.0	-11.7
47.745	15.96	30.00	14.04	10000.0	120.000	109.6	V	334.0	-11.5
50.483	19.11	30.00	10.89	10000.0	120.000	104.5	V	343.0	-11.4
65.743	16.46	30.00	13.54	10000.0	120.000	99.9	V	315.0	-12.3
150.007	18.61	30.00	11.39	10000.0	120.000	189.8	V	127.0	-9.8
199.998	19.57	30.00	10.43	10000.0	120.000	214.9	V	79.0	-12.4

< Fig 11. Radiated emission result (30 MHz ~ 1 000 MHz) >



- Operating condition: Network Communication mode(Digital input & AC-DC Adapter)
- Black(◆) marker: Quasi Peak detector;
- Pink line: Peak value of vertical polarization ; Blue line: Peak value of Horizontal polarization

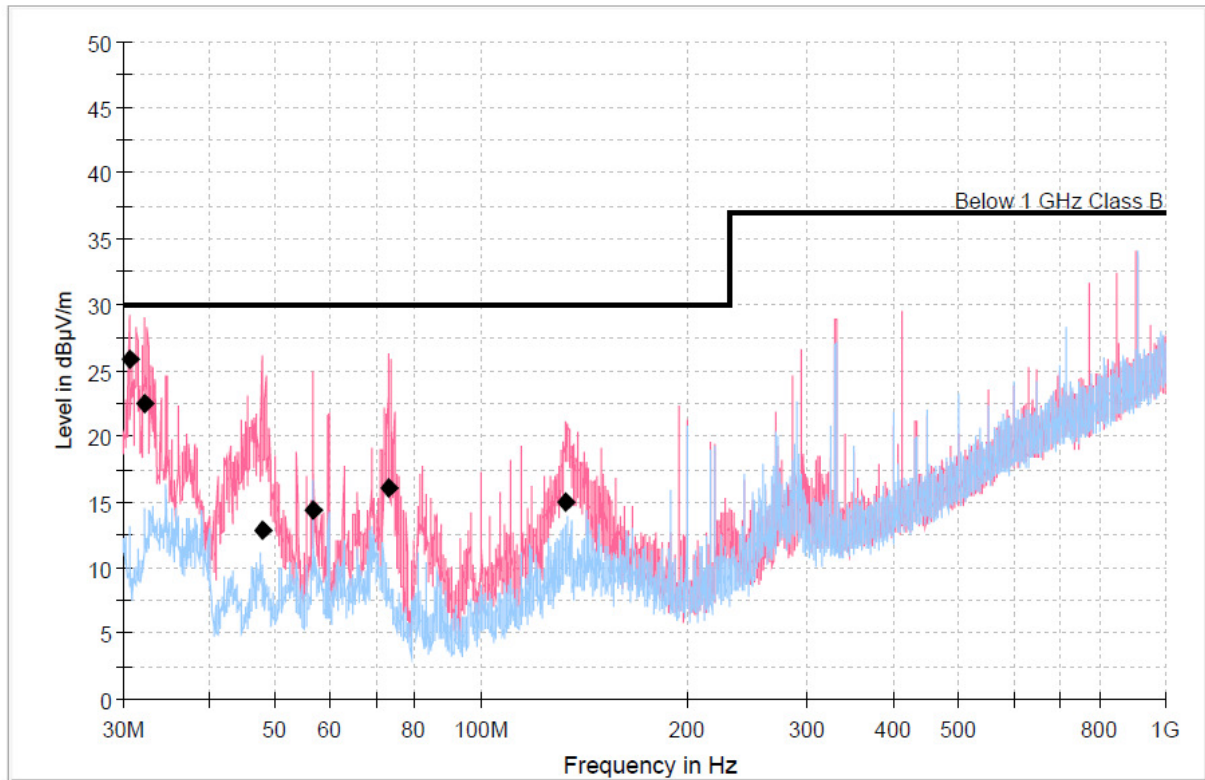

Final Result

Frequency (MHz)	QuasiPeak (dBµV/m)	Limit (dBµV/m)	Margin (dB)	Meas. Time (ms)	Bandwidth (kHz)	Height (cm)	Pol	Azimuth (deg)	Corr. (dB)
30.594	25.87	30.00	4.13	10000.0	120.000	390.1	V	296.0	-13.2
32.236	22.55	30.00	7.45	10000.0	120.000	390.1	V	291.0	-13.0
47.804	12.77	30.00	17.23	10000.0	120.000	294.8	V	353.0	-11.5
56.823	14.31	30.00	15.69	10000.0	120.000	104.1	V	63.0	-11.5
73.162	16.01	30.00	13.99	10000.0	120.000	294.3	V	6.0	-13.5
133.262	15.03	30.00	14.97	10000.0	120.000	115.0	V	173.0	-10.5

< Fig 12. Radiated emission result (30 MHz ~ 1 000 MHz) >



- Operating condition: Network Communication mode(Analog input & PoE Injector)
- Black(◆) marker: Quasi Peak detector;
- Pink line: Peak value of vertical polarization ; Blue line: Peak value of Horizontal polarization

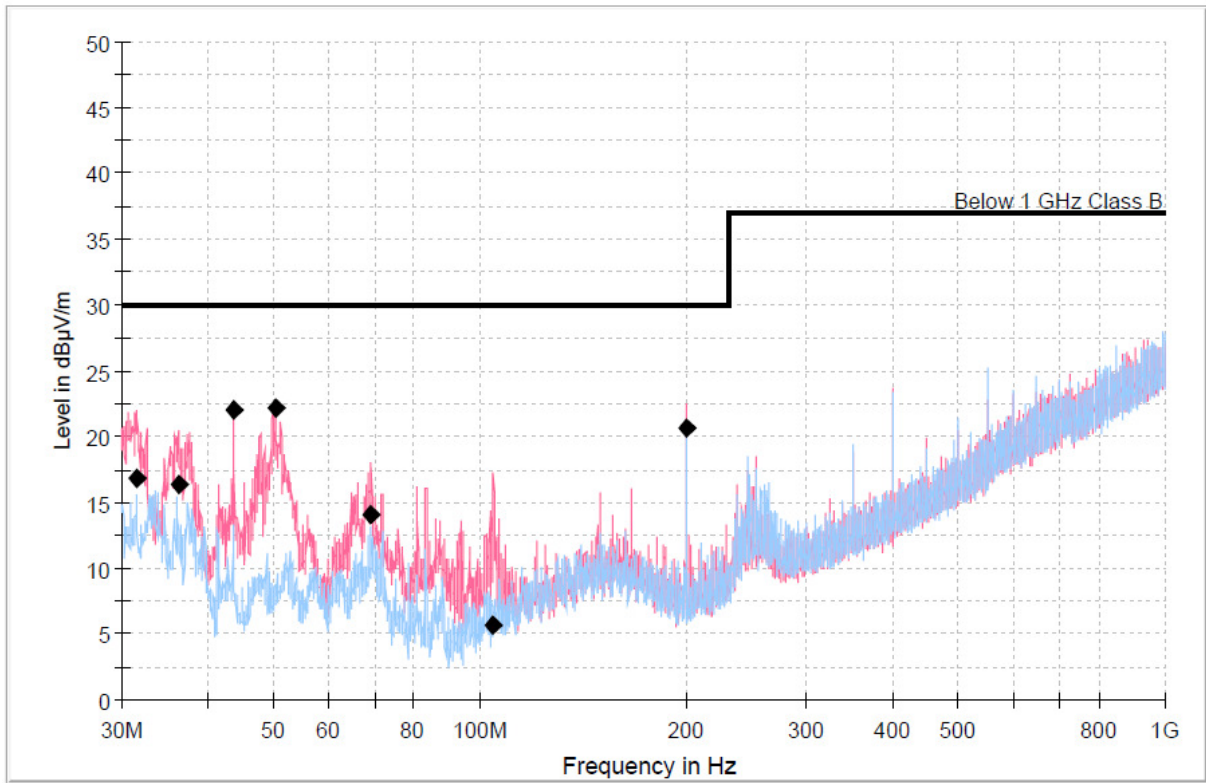

Final Result

Frequency (MHz)	QuasiPeak (dBµV/m)	Limit (dBµV/m)	Margin (dB)	Meas. Time (ms)	Bandwidth (kHz)	Height (cm)	Pol	Azimuth (deg)	Corr. (dB)
31.537	16.77	30.00	13.23	10000.0	120.000	400.0	V	217.0	-13.1
36.236	16.33	30.00	13.67	10000.0	120.000	104.1	V	1.0	-12.7
43.737	22.02	30.00	7.98	10000.0	120.000	100.0	V	256.0	-11.7
50.429	22.18	30.00	7.82	10000.0	120.000	115.1	V	271.0	-11.4
69.433	14.11	30.00	15.89	10000.0	120.000	102.1	V	229.0	-12.7
104.729	5.64	30.00	24.36	10000.0	120.000	100.0	V	237.0	-13.4
199.996	20.57	30.00	9.43	10000.0	120.000	100.0	V	15.0	-12.4

< Fig 13. Radiated emission result (30 MHz ~ 1 000 MHz) >



- Operating condition: Network Communication mode(Analog input & AC-DC Adapter)
- Black(◆) marker: Quasi Peak detector;
- Pink line: Peak value of vertical polarization; Blue line: Peak value of Horizontal polarization

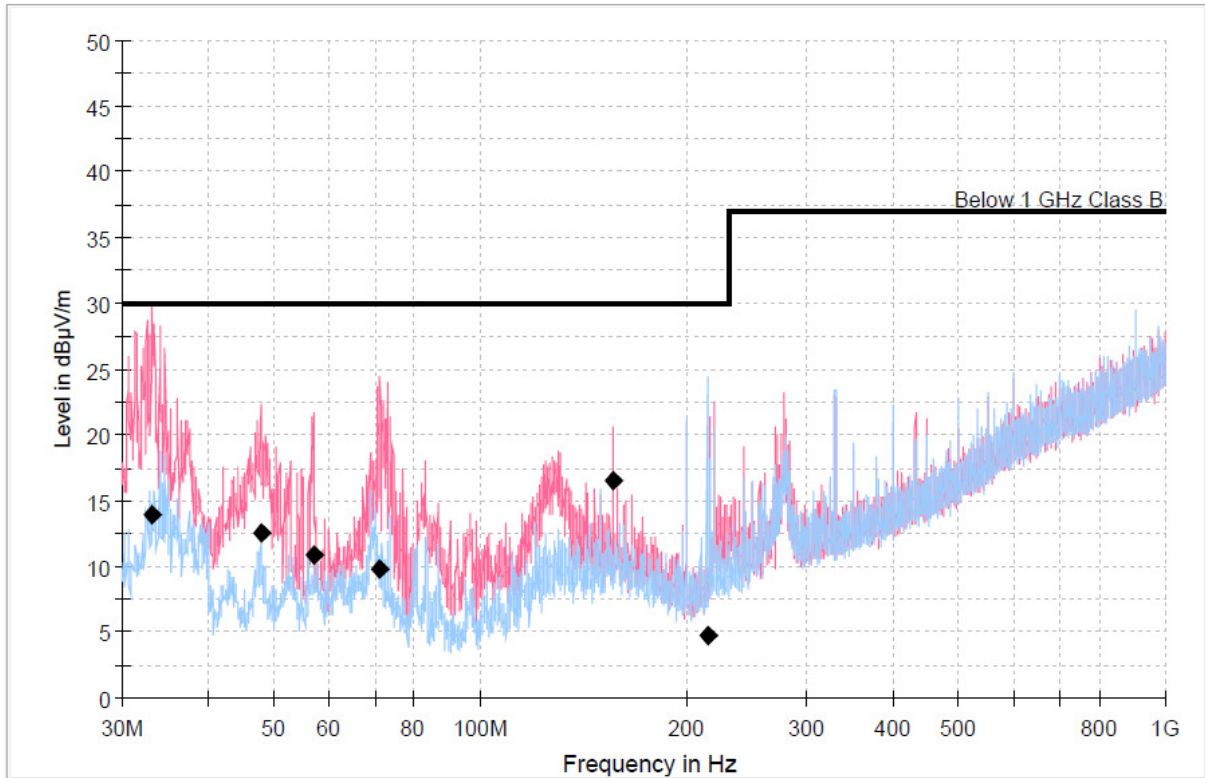

Final Result

Frequency (MHz)	QuasiPeak (dBµV/m)	Limit (dBµV/m)	Margin (dB)	Meas. Time (ms)	Bandwidth (kHz)	Height (cm)	Pol	Azimuth (deg)	Corr. (dB)
33.174	13.93	30.00	16.07	10000.0	120.000	215.1	V	294.0	-13.0
47.797	12.48	30.00	17.52	10000.0	120.000	184.9	V	287.0	-11.5
57.072	10.84	30.00	19.16	10000.0	120.000	115.1	V	48.0	-11.5
71.128	9.84	30.00	20.16	10000.0	120.000	197.3	V	302.0	-13.0
156.283	16.45	30.00	13.55	10000.0	120.000	100.0	V	159.0	-9.6
214.290	4.68	30.00	25.32	10000.0	120.000	389.3	H	121.0	-11.8

< Fig 14. Radiated emission result (30 MHz ~ 1 000 MHz) >



- Operating condition: Network Communication mode(Optical input & PoE Injector)
- Black(◆) marker: Quasi Peak detector; Pink line: Peak value of vertical polarization ; Blue lien: Peak value of Horizontal polarization

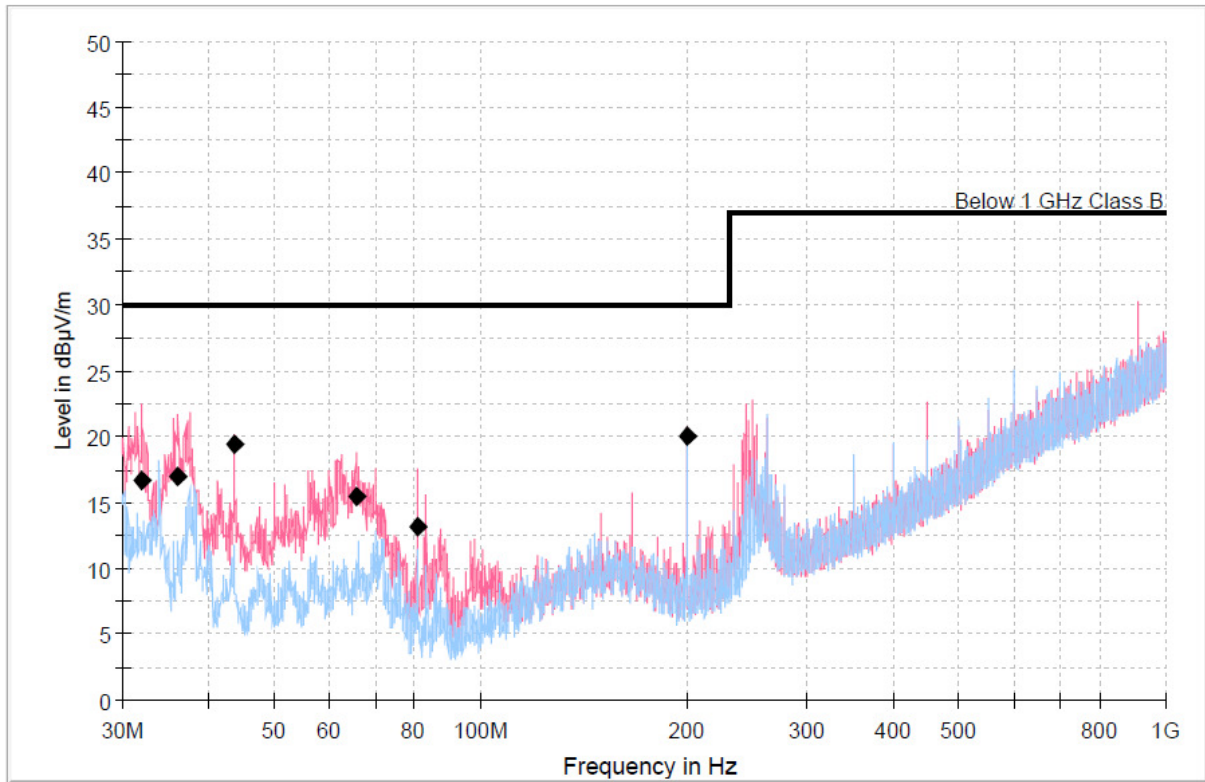

Final Result

Frequency (MHz)	QuasiPeak (dBµV/m)	Limit (dBµV/m)	Margin (dB)	Meas. Time (ms)	Bandwidth (kHz)	Height (cm)	Pol	Azimuth (deg)	Corr. (dB)
31.975	16.70	30.00	13.30	10000.0	120.000	289.5	V	177.0	-13.1
36.032	16.93	30.00	13.07	10000.0	120.000	103.8	V	89.0	-12.7
43.747	19.48	30.00	10.52	10000.0	120.000	109.4	V	68.0	-11.7
66.045	15.37	30.00	14.63	10000.0	120.000	284.9	V	265.0	-12.3
80.894	13.09	30.00	16.91	10000.0	120.000	315.0	V	15.0	-15.1
199.991	19.97	30.00	10.03	10000.0	120.000	384.9	V	211.0	-12.4

< Fig 15. Radiated emission result (30 MHz ~ 1 000 MHz) >



- Operating condition: Network Communication mode(Optical input & AC-DC Adapter)
- Black(◆) marker: Quasi Peak detector;
- Pink line: Peak value of vertical polarization ; Blue line: Peak value of Horizontal polarization

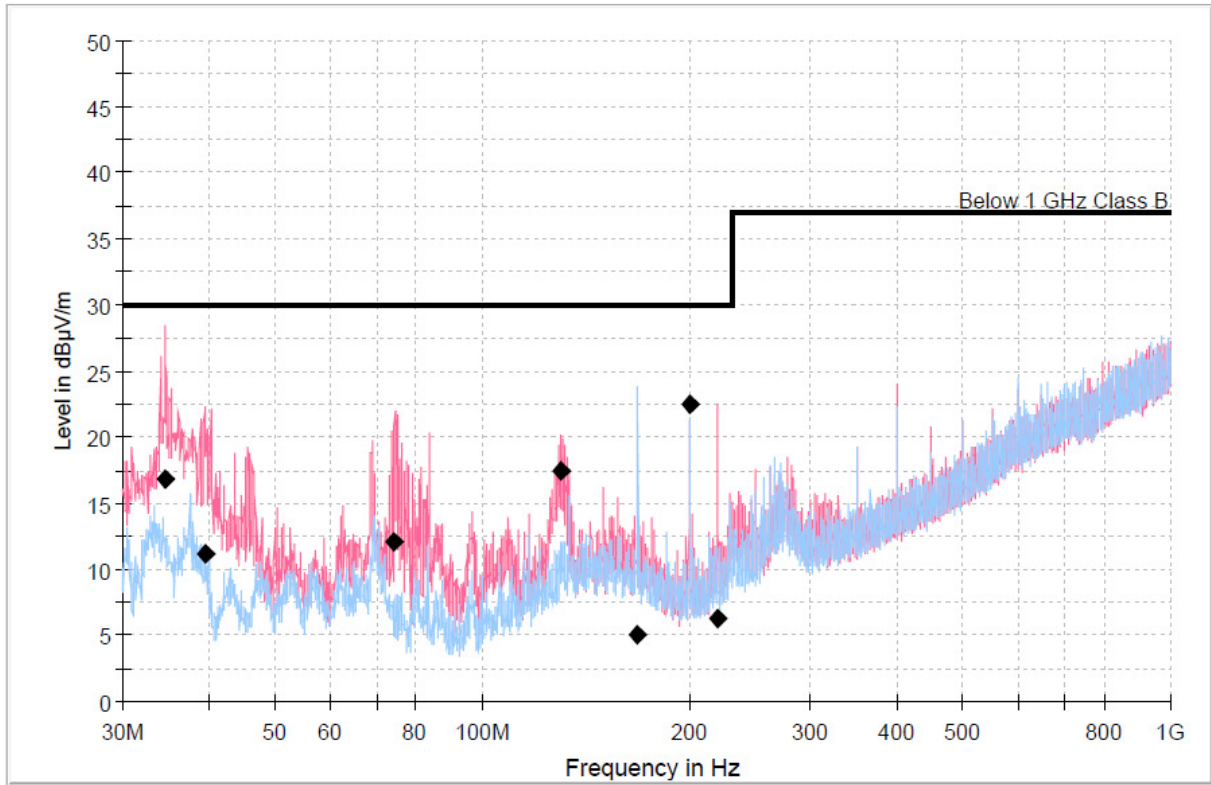

Final Result

Frequency (MHz)	QuasiPeak (dBµV/m)	Limit (dBµV/m)	Margin (dB)	Meas. Time (ms)	Bandwidth (kHz)	Height (cm)	Pol	Azimuth (deg)	Corr. (dB)
34.653	16.76	30.00	13.24	10000.0	120.000	301.3	V	295.0	-12.9
39.494	11.17	30.00	18.83	10000.0	120.000	284.2	V	254.0	-12.2
74.536	12.09	30.00	17.91	10000.0	120.000	279.2	V	225.0	-13.8
130.271	17.45	30.00	12.55	10000.0	120.000	106.9	V	48.0	-10.7
168.263	5.12	30.00	24.88	10000.0	120.000	105.4	H	-15.0	-10.1
200.001	22.50	30.00	7.50	10000.0	120.000	400.0	H	-23.0	-12.4
220.007	6.31	30.00	23.69	10000.0	120.000	125.0	V	350.0	-11.5

< Fig 16. Radiated emission result (30 MHz ~ 1 000 MHz) >



-. 1 GHz ~ 5 GHz

▪ Operating condition: Network Communication mode(Digital input & PoE Injector)

Black(◆) marker: Average detector, Blue (◆)marker: Peak detector

Pink line: Peak value of vertical polarization ; Blue lien: Peak value of Horizontal polarization

Black line: Average value of vertical polarization ; Green lien: Peak value of Horizontal polarization

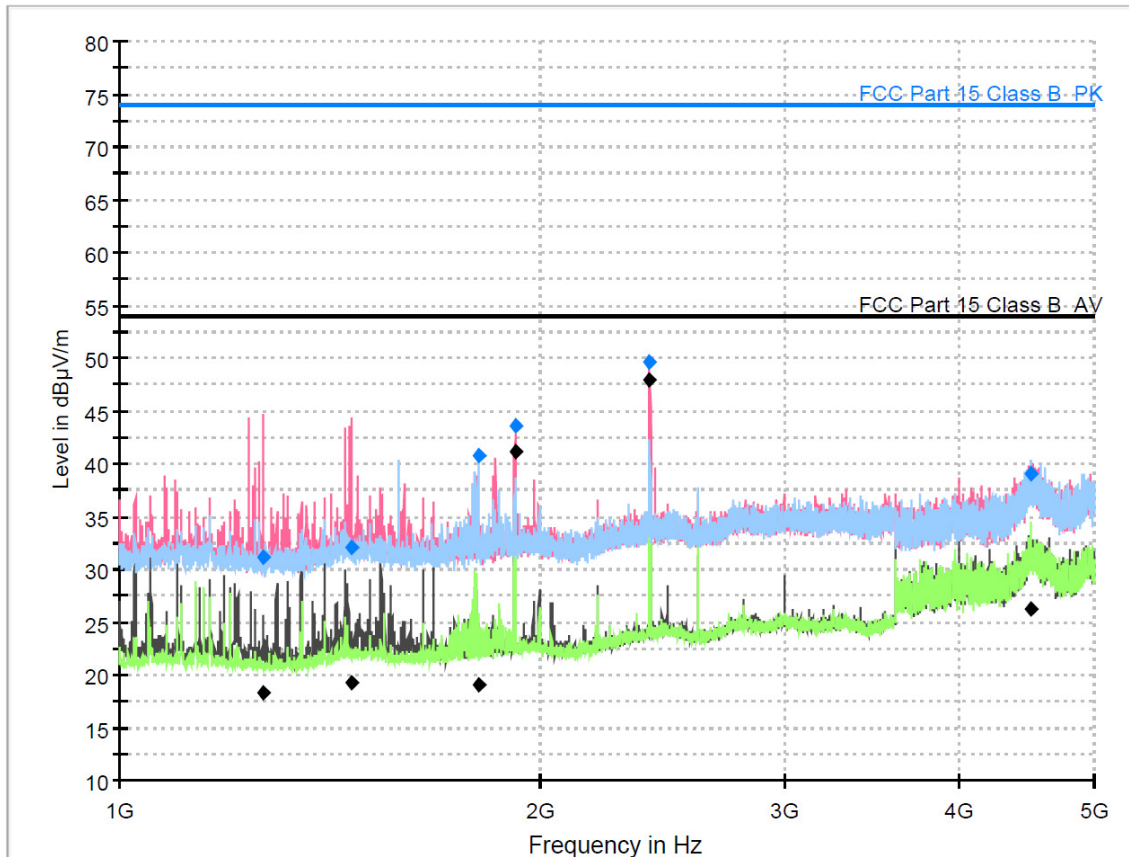

Final Result

Frequency (MHz)	MaxPeak (dBµV/m)	CAverage (dBµV/m)	Limit (dBµV/m)	Margin (dB)	Meas. Time (ms)	Bandwidth (kHz)	Height (cm)	Pol	Azimuth (deg)	Corr. (dB)
1268.125	---	18.31	54.00	35.69	1000.0	1000.000	207.0	V	39.0	-12.9
1268.125	31.14	---	74.00	42.86	1000.0	1000.000	207.0	V	39.0	-12.9
1467.188	32.10	---	74.00	41.90	1000.0	1000.000	203.0	V	32.0	-12.6
1467.188	---	19.17	54.00	34.83	1000.0	1000.000	203.0	V	32.0	-12.6
1807.188	40.71	---	74.00	33.29	1000.0	1000.000	110.0	H	20.0	-11.9
1807.188	---	19.05	54.00	34.95	1000.0	1000.000	110.0	H	20.0	-11.9
1920.313	---	41.06	54.00	12.94	1000.0	1000.000	107.0	V	312.0	-11.8
1920.313	43.66	---	74.00	30.34	1000.0	1000.000	107.0	V	312.0	-11.8
2400.625	49.58	---	74.00	24.42	1000.0	1000.000	106.0	V	334.0	-10.0
2400.625	---	47.99	54.00	6.01	1000.0	1000.000	106.0	V	334.0	-10.0
4506.563	39.03	---	74.00	34.97	1000.0	1000.000	110.0	V	38.0	-5.2
4506.563	---	26.23	54.00	27.77	1000.0	1000.000	110.0	V	38.0	-5.2

< Fig 17. Radiated emission result (1 000 MHz ~5 000 MHz) >



- Operating condition: Network Communication mode(Digital input & AC-DC Adapter)
- Black(◆) marker: Average detector, Blue (◆)marker: Peak detector
- Pink line: Peak value of vertical polarization ; Blue lien: Peak value of Horizontal polarization
- Black line: Average value of vertical polarization ; Green lien: Peak value of Horizontal polarization

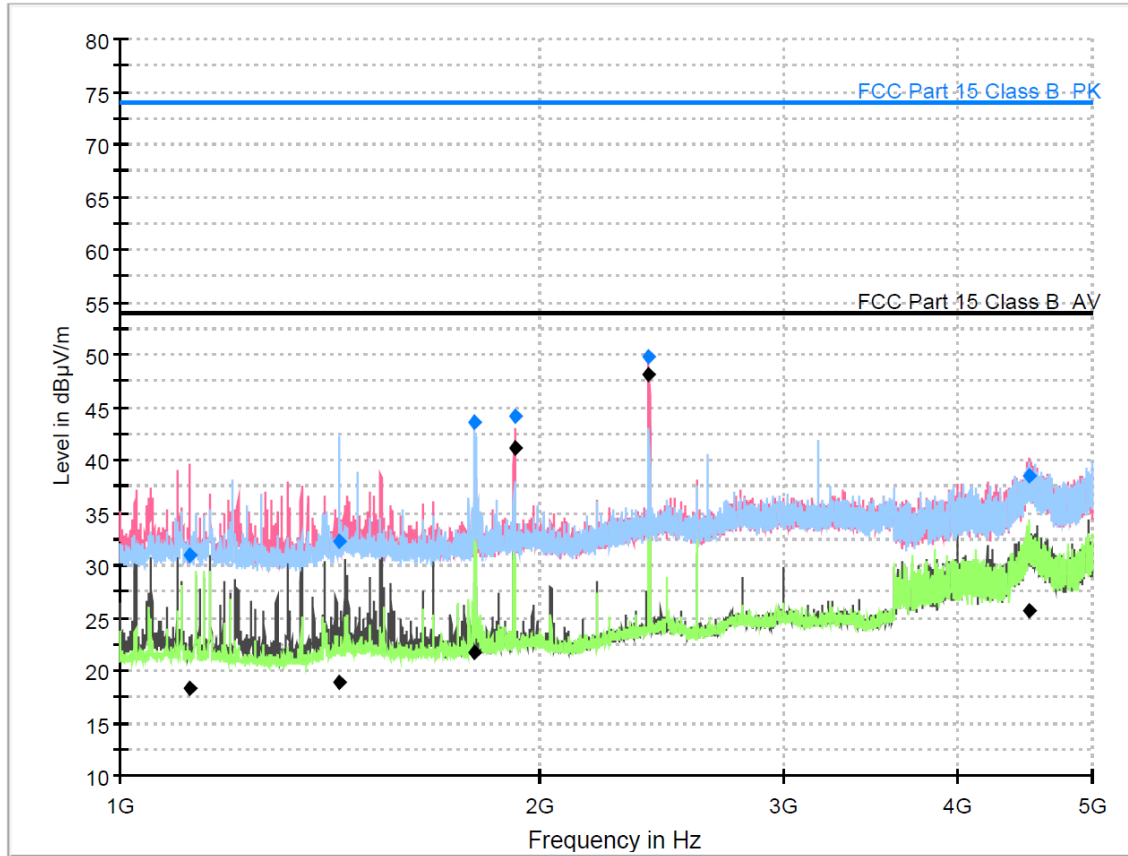

Final Result

Frequency (MHz)	MaxPeak (dBµV/m)	CAverage (dBµV/m)	Limit (dBµV/m)	Margin (dB)	Meas. Time (ms)	Bandwidth (kHz)	Height (cm)	Pol	Azimuth (deg)	Corr. (dB)
1121.563	---	18.37	54.00	35.63	1000.0	1000.000	225.0	V	96.0	-13.5
1121.563	31.01	---	74.00	42.99	1000.0	1000.000	225.0	V	96.0	-13.5
1437.500	---	18.87	54.00	35.13	1000.0	1000.000	220.0	H	209.0	-12.7
1437.500	32.29	---	74.00	41.71	1000.0	1000.000	220.0	H	209.0	-12.7
1798.750	43.63	---	74.00	30.37	1000.0	1000.000	100.0	H	24.0	-11.9
1798.750	---	21.67	54.00	32.33	1000.0	1000.000	100.0	H	24.0	-11.9
1920.313	---	41.18	54.00	12.82	1000.0	1000.000	100.0	V	314.0	-11.8
1920.313	44.14	---	74.00	29.86	1000.0	1000.000	100.0	V	314.0	-11.8
2400.625	---	48.03	54.00	5.97	1000.0	1000.000	107.0	V	333.0	-10.0
2400.625	49.72	---	74.00	24.28	1000.0	1000.000	107.0	V	333.0	-10.0
4508.438	38.42	---	74.00	35.58	1000.0	1000.000	125.0	V	212.0	-5.2
4508.438	---	25.59	54.00	28.41	1000.0	1000.000	125.0	V	212.0	-5.2

< Fig 18. Radiated emission result (1 000 MHz ~5 000 MHz) >



- Operating condition: Network Communication mode(Analog input & PoE Injector)
- Black(◆) marker: Average detector, Blue (◆)marker: Peak detector
- Pink line: Peak value of vertical polarization ; Blue lien: Peak value of Horizontal polarization
- Black line: Average value of vertical polarization ; Green lien: Peak value of Horizontal polarization

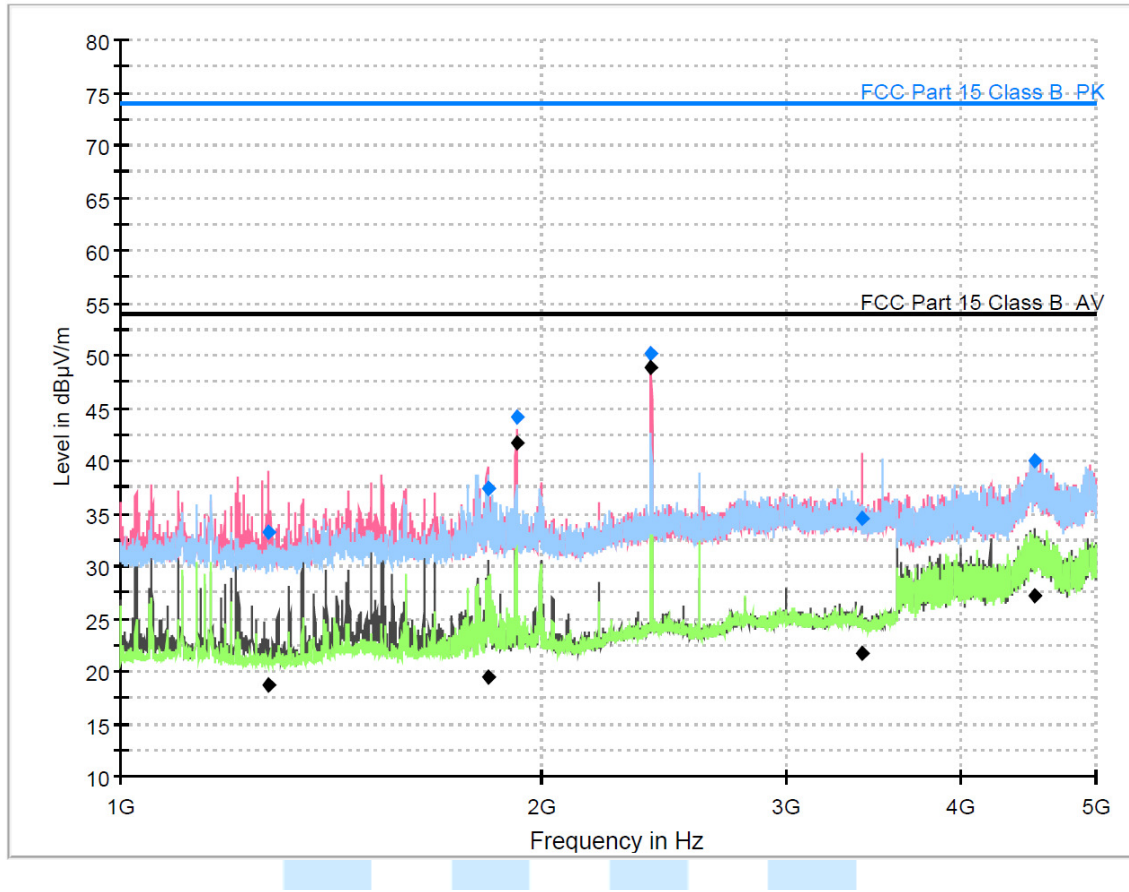

Final Result

Frequency (MHz)	MaxPeak (dBµV/m)	CAverage (dBµV/m)	Limit (dBµV/m)	Margin (dB)	Meas. Time (ms)	Bandwidth (kHz)	Height (cm)	Pol	Azimuth (deg)	Corr. (dB)
1277.813	---	18.59	54.00	35.41	1000.0	1000.000	110.0	V	-43.0	-12.9
1277.813	33.12	---	74.00	40.88	1000.0	1000.000	110.0	V	-43.0	-12.9
1830.938	---	19.44	54.00	34.56	1000.0	1000.000	109.0	V	222.0	-11.9
1830.938	37.28	---	74.00	36.72	1000.0	1000.000	109.0	V	222.0	-11.9
1920.313	---	41.68	54.00	12.32	1000.0	1000.000	100.0	V	314.0	-11.8
1920.313	44.16	---	74.00	29.84	1000.0	1000.000	100.0	V	314.0	-11.8
2400.625	50.10	---	74.00	23.90	1000.0	1000.000	100.0	V	332.0	-10.0
2400.625	---	48.80	54.00	5.20	1000.0	1000.000	100.0	V	332.0	-10.0
3395.000	34.52	---	74.00	39.48	1000.0	1000.000	125.0	V	341.0	-8.4
3395.000	---	21.70	54.00	32.30	1000.0	1000.000	125.0	V	341.0	-8.4
4518.750	---	27.14	54.00	26.86	1000.0	1000.000	225.0	V	179.0	-3.3
4518.750	39.97	---	74.00	34.03	1000.0	1000.000	225.0	V	179.0	-3.3

< Fig 19. Radiated emission result (1 000 MHz ~5 000 MHz) >



- Operating condition: Network Communication mode(Analog input & AC-DC Adapter)
- Black(◆) marker: Average detector, Blue (◆)marker: Peak detector
- Pink line: Peak value of vertical polarization ; Blue lien: Peak value of Horizontal polarization
- Black line: Average value of vertical polarization ; Green lien: Peak value of Horizontal polarization



Final Result

Frequency (MHz)	MaxPeak (dBµV/m)	CAverage (dBµV/m)	Limit (dBµV/m)	Margin (dB)	Meas. Time (ms)	Bandwidth (kHz)	Height (cm)	Pol	Azimuth (deg)	Corr. (dB)
1100.313	---	28.20	54.00	25.80	1000.0	1000.000	100.0	V	340.0	-13.5
1100.313	39.98	---	74.00	34.02	1000.0	1000.000	100.0	V	340.0	-13.5
1539.063	---	27.00	54.00	27.00	1000.0	1000.000	100.0	V	337.0	-12.5
1539.063	38.83	---	74.00	35.17	1000.0	1000.000	100.0	V	337.0	-12.5
1799.063	---	21.39	54.00	32.61	1000.0	1000.000	107.0	H	-9.0	-11.9
1799.063	44.72	---	74.00	29.28	1000.0	1000.000	107.0	H	-9.0	-11.9
1920.313	45.91	---	74.00	28.09	1000.0	1000.000	100.0	V	313.0	-11.8
1920.313	---	41.82	54.00	12.18	1000.0	1000.000	100.0	V	313.0	-11.8
2400.313	---	47.27	54.00	6.73	1000.0	1000.000	107.0	V	334.0	-10.0
2400.313	49.05	---	74.00	24.95	1000.0	1000.000	107.0	V	334.0	-10.0
4497.188	40.05	---	74.00	33.95	1000.0	1000.000	202.0	H	42.0	-3.3
4497.188	---	27.13	54.00	26.87	1000.0	1000.000	202.0	H	42.0	-3.3

< Fig 20. Radiated emission result (1 000 MHz ~5 000 MHz) >



- Operating condition: Network Communication mode(Optical input & PoE Injector)
- Black(◆) marker: Average detector, Blue (◆)marker: Peak detector
- Pink line: Peak value of vertical polarization ; Blue lien: Peak value of Horizontal polarization
- Black line: Average value of vertical polarization ; Green lien: Peak value of Horizontal polarization

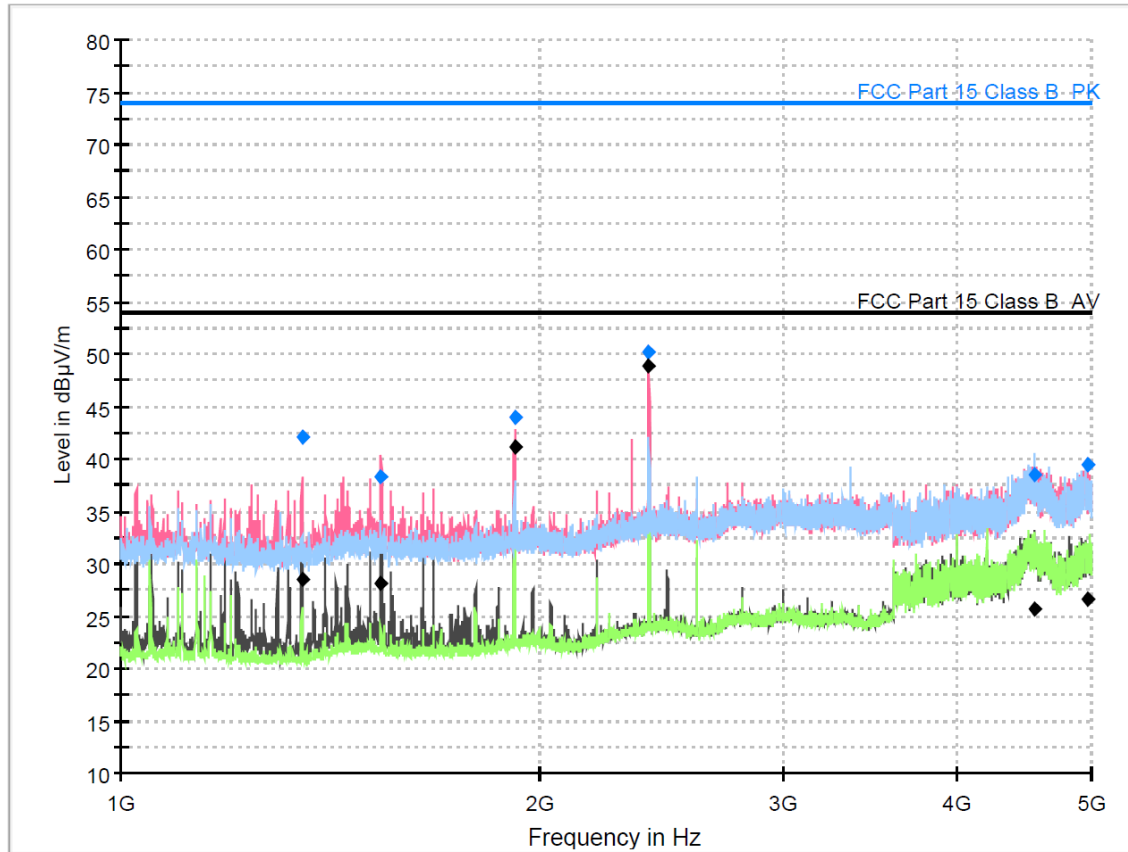

Final Result

Frequency (MHz)	MaxPeak (dBµV/m)	CAverage (dBµV/m)	Limit (dBµV/m)	Margin (dB)	Meas. Time (ms)	Bandwidth (kHz)	Height (cm)	Pol	Azimuth (deg)	Corr. (dB)
1349.688	42.11	---	74.00	31.89	1000.0	1000.000	112.0	V	0.0	-12.8
1349.688	---	28.43	54.00	25.57	1000.0	1000.000	112.0	V	0.0	-12.8
1540.313	---	28.20	54.00	25.80	1000.0	1000.000	106.0	V	339.0	-12.5
1540.313	38.39	---	74.00	35.61	1000.0	1000.000	106.0	V	339.0	-12.5
1920.313	---	41.14	54.00	12.86	1000.0	1000.000	100.0	V	315.0	-11.8
1920.313	43.95	---	74.00	30.05	1000.0	1000.000	100.0	V	315.0	-11.8
2400.625	50.18	---	74.00	23.82	1000.0	1000.000	100.0	V	333.0	-10.0
2400.625	---	48.79	54.00	5.21	1000.0	1000.000	100.0	V	333.0	-10.0
4550.938	---	25.75	54.00	28.25	1000.0	1000.000	125.0	H	163.0	-5.2
4550.938	38.40	---	74.00	35.60	1000.0	1000.000	125.0	H	163.0	-5.2
4971.813	---	26.64	54.00	27.36	1000.0	1000.000	210.0	V	282.0	-3.4
4971.813	39.36	---	74.00	34.64	1000.0	1000.000	210.0	V	282.0	-3.4

< Fig 21. Radiated emission result (1 000 MHz ~5 000 MHz) >



- Operating condition: Network Communication mode(Optical input & AC-DC Adapter)
- Black(◆) marker: Average detector, Blue (◆)marker: Peak detector
- Pink line: Peak value of vertical polarization ; Blue lien: Peak value of Horizontal polarization
- Black line: Average value of vertical polarization ; Green lien: Peak value of Horizontal polarization

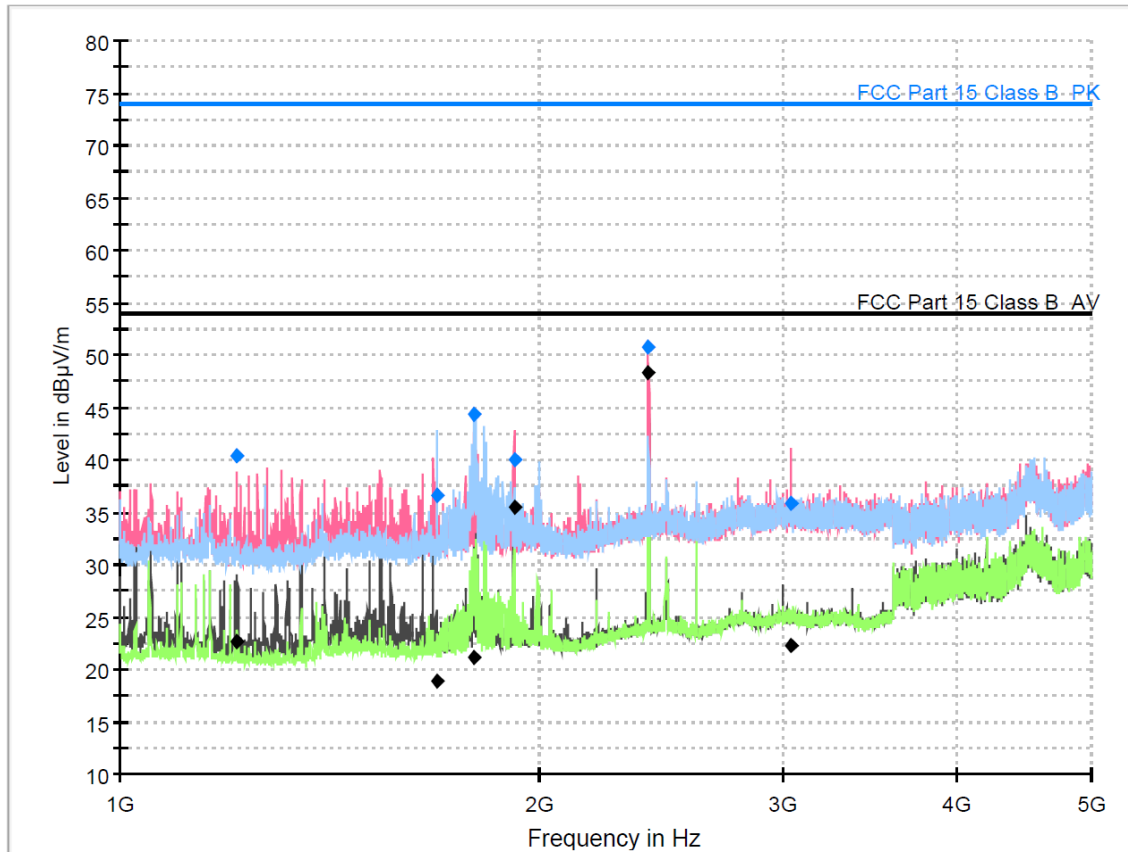

Final Result

Frequency (MHz)	MaxPeak (dBµV/m)	CAverage (dBµV/m)	Limit (dBµV/m)	Margin (dB)	Meas. Time (ms)	Bandwidth (kHz)	Height (cm)	Pol	Azimuth (deg)	Corr. (dB)
1214.375	---	22.70	54.00	31.30	1000.0	1000.000	100.0	V	358.0	-13.1
1214.375	40.46	---	74.00	33.54	1000.0	1000.000	100.0	V	358.0	-13.1
1690.938	---	18.80	54.00	35.20	1000.0	1000.000	225.0	H	45.0	-12.2
1690.938	36.63	---	74.00	37.37	1000.0	1000.000	225.0	H	45.0	-12.2
1795.938	44.35	---	74.00	29.65	1000.0	1000.000	107.0	H	-2.0	-11.9
1795.938	---	21.18	54.00	32.82	1000.0	1000.000	107.0	H	-2.0	-11.9
1920.000	---	35.51	54.00	18.49	1000.0	1000.000	100.0	V	344.0	-11.8
1920.000	40.08	---	74.00	33.92	1000.0	1000.000	100.0	V	344.0	-11.8
2400.625	50.73	---	74.00	23.27	1000.0	1000.000	107.0	V	331.0	-10.0
2400.625	---	48.39	54.00	5.61	1000.0	1000.000	107.0	V	331.0	-10.0
3034.688	---	22.19	54.00	31.81	1000.0	1000.000	220.0	V	17.0	-8.3
3034.688	35.78	---	74.00	38.22	1000.0	1000.000	220.0	V	17.0	-8.3

< Fig 22. Radiated emission result (1 000 MHz ~5 000 MHz) >



11. Sample Calculations

$$\begin{aligned} \text{dB}\mu\text{V} &= 20 \text{ Log}_{10}(\mu\text{V}/\text{m}) \\ \text{dB}\mu\text{V} &= \text{dBm} + 107 \\ \mu\text{V} &= 10^{(\text{dB}\mu\text{V}/20)} \end{aligned}$$

11.1 Example 1 :

■ 20.3 MHz

Class B Limit	= 250 μV = 48 dB μV
Reading	= 39.2 dB μV
$10^{(39.2\text{dB}\mu\text{V}/20)}$	= 91.2 μV
Margin	= 48 dB μV - 39.2 dB μV
	= 8.8 dB

11.2 Example 2 :

■ 66.7 MHz

Class B Limit	= 100 $\mu\text{V}/\text{m}$ = 40.0 dB $\mu\text{V}/\text{m}$
Reading	= 31.0 dB μV
Antenna Factor + Cable Loss	= 5.8 dB
Total	= 36.8 dB $\mu\text{V}/\text{m}$
Margin	= 40.0 dB $\mu\text{V}/\text{m}$ - 36.8 dB $\mu\text{V}/\text{m}$
	= 3.2 dB



12. Recommendation & Conclusion

The data collected shows that the **OHSUNG ELECTRONICS CO.,LTD.**
Stream Injector Input Device (Model Name: DMS-IN) was complies with §15.107, 15.109 of the FCC Rules.

- The end -

