

# Radio Test Report

## FCC ID: OYRCF-924AC

### Original Grant

**Report No.** : TB-FCC179822

**Applicant** : Shenzhen Four Seas Global Link Network Technology Co., Ltd.

**Equipment Under Test (EUT)**

**EUT Name** : AC Wireless Network Card

**Model No.** : CF-924AC V2

**Series Model No.** : CF-821AC, CF-813B, CF-727B, CF-938AC, CF-926AC, CF-926AC PRO, CF-WU785AC, CF-WU783AC, CF-958AC, CF-939AC

**Brand Name** : ----

**Sample ID** : 20210402-14-1#& 20210402-14-2#

**Receipt Date** : 2021-04-15

**Test Date** : 2021-04-16 to 2021-04-28

**Issue Date** : 2021-04-29

**Standards** : FCC Part 15, Subpart C 15.247

**Test Method** : ANSI C63.10: 2013  
KDB 558074 D01 15.247 Meas Guidance v05r02  
KDB 662911 D01 Multiple Transmitter Output v02r01

**Conclusions** : **PASS**

In the configuration tested, the EUT complied with the standards specified above.

**Test/Witness Engineer** : *Rebecca*

**Engineer Supervisor** : *Wan Su*

**Engineer Manager** : *Ray Lai*



This report details the results of the testing carried out on one sample. The results contained in this test report do not relate to other samples of the same product. The manufacturer should ensure that all products in series production are in conformity with the product sample detailed in the report.

## Contents

<b>CONTENTS</b> .....	<b>2</b>
<b>1. GENERAL INFORMATION ABOUT EUT</b> .....	<b>5</b>
1.1 Client Information.....	5
1.2 General Description of EUT (Equipment Under Test) .....	5
1.3 Block Diagram Showing the Configuration of System Tested.....	6
1.4 Description of Support Units .....	6
1.5 Description of Test Mode.....	7
1.6 Description of Test Software Setting .....	8
1.7 Measurement Uncertainty .....	9
1.8 Test Facility.....	9
<b>2. TEST SUMMARY</b> .....	<b>10</b>
<b>3. TEST SOFTWARE</b> .....	<b>10</b>
<b>4. TEST EQUIPMENT</b> .....	<b>11</b>
<b>5. CONDUCTED EMISSION TEST</b> .....	<b>12</b>
5.1 Test Standard and Limit.....	12
5.2 Test Setup.....	12
5.3 Test Procedure.....	13
5.4 Deviation From Test Standard.....	13
5.5 EUT Operating Mode .....	13
5.6 Test Data.....	13
<b>6. RADIATED EMISSION TEST</b> .....	<b>14</b>
6.1 Test Standard and Limit.....	14
6.2 Test Setup.....	15
6.3 Test Procedure.....	16
6.4 Deviation From Test Standard.....	17
6.5 EUT Operating Condition .....	17
6.6 Test Data.....	17
<b>7. RESTRICTED BANDS REQUIREMENT</b> .....	<b>18</b>
7.1 Test Standard and Limit.....	18
7.2 Test Setup.....	18
7.3 Test Procedure.....	19
7.4 Deviation From Test Standard.....	19
7.5 EUT Operating Condition .....	19
7.6 Test Data.....	19
<b>8. BANDWIDTH TEST</b> .....	<b>20</b>
8.1 Test Standard and Limit.....	20
8.2 Test Setup.....	20
8.3 Test Procedure.....	20
8.4 Deviation From Test Standard.....	20

---

8.5 EUT Operating Condition .....	20
8.6 Test Data.....	20
<b>9. PEAK OUTPUT POWER.....</b>	<b>21</b>
9.1 Test Standard and Limit.....	21
9.2 Test Setup.....	21
9.3 Test Procedure.....	21
9.4 Deviation From Test Standard.....	21
9.5 EUT Operating Condition .....	21
9.6 Test Data.....	21
<b>10. POWER SPECTRAL DENSITY TEST .....</b>	<b>22</b>
10.1 Test Standard and Limit .....	22
10.2 Test Setup.....	22
10.3 Test Procedure.....	22
10.4 Deviation From Test Standard.....	22
10.5 EUT Operating Condition .....	22
10.6 Test Data.....	22
<b>11. ANTENNA REQUIREMENT.....</b>	<b>23</b>
11.1 Standard Requirement.....	23
11.2 Deviation From Test Standard.....	23
11.3 Antenna Connected Construction.....	23
<b>ATTACHMENT A-- CONDUCTED EMISSION TEST DATA .....</b>	<b>24</b>
<b>ATTACHMENT B-- RADIATED EMISSION TEST DATA .....</b>	<b>26</b>
<b>ATTACHMENT C-- RESTRICTED BANDS REQUIREMENT AND BAND-EDGE TEST DATA .....</b>	<b>40</b>
<b>ATTACHMENT D-- BANDWIDTH TEST DATA.....</b>	<b>63</b>
<b>ATTACHMENT E-- PEAK OUTPUT POWER DATA .....</b>	<b>72</b>
<b>ATTACHMENT F-- POWER SPECTRAL DENSITY TEST DATA.....</b>	<b>76</b>

## Revision History

Report No.	Version	Description	Issued Date
TB-FCC179822	Rev.01	Initial issue of report	2021-04-29

# 1. General Information about EUT

## 1.1 Client Information

<b>Applicant</b>	:	Shenzhen Four Seas Global Link Network Technology Co., Ltd.
<b>Address</b>	:	Room 607-610, Block B, TAOJINDI Electronic Business Incubation Base, Tenglong Road, Longhua District, Shenzhen, China
<b>Manufacturer</b>	:	Shenzhen Four Seas Global Link Network Technology Co., Ltd.
<b>Address</b>	:	Room 607-610, Block B, TAOJINDI Electronic Business Incubation Base, Tenglong Road, Longhua District, Shenzhen, China

## 1.2 General Description of EUT (Equipment Under Test)

<b>EUT Name</b>	:	AC Wireless Network Card
<b>Models No.</b>	:	CF-924AC V2, CF-821AC, CF-813B, CF-727B, CF-938AC, CF-926AC, CF-926AC PRO, CF-WU785AC, CF-WU783AC, CF-958AC, CF-939AC
<b>Model Different</b>	:	All these models are identical in the same PCB, layout and electrical circuit, The only difference is appearance color and model name.
<b>Product Description</b>	Operation Frequency:	802.11b/g/n(HT20): 2412MHz~2462MHz 802.11n(HT40): 2422MHz~2452MHz
	Number of Channel:	802.11b/g/n(HT20):11 channels <b>see note(3)</b> 802.11n(HT40): 7 channels <b>see note(3)</b>
	Antenna Gain:	Please see Note(3)
	Modulation Type:	802.11b: DSSS(CCK, DQPSK, DBPSK) 802.11g/n:OFDM(BPSK,QPSK,16QAM,64QAM)
	Bit Rate of Transmitter:	802.11b:11/5.5/2/1 Mbps 802.11g:54/48/36/24/18/12/9/6 Mbps 802.11n:up to 150Mbps
<b>Power Rating</b>	:	USB Input: DC 5V
<b>Software Version</b>	:	N/A
<b>Hardware Version</b>	:	N/A
<b>Remark</b>	:	The antenna gain provided by the applicant, the verified for the RF conduction test provided by TOBY test lab.

**Note:**

- (1) For a more detailed features description, please refer to the manufacturer's specifications or the User's Manual.

## (2) Channel List:

Channel	Frequency (MHz)	Channel	Frequency (MHz)	Channel	Frequency (MHz)
01	2412	05	2432	09	2452
02	2417	06	2437	10	2457
03	2422	07	2442	11	2462
04	2427	08	2447		

Note: CH 01~CH 11 for 802.11b/g/n(HT20)  
CH 03~CH 09 for 802.11n(HT40)

## (3) Antenna information

Mode		TX Antenna (s)		Remark	
802.11b		1		The worst case is ANT. A TX	
802.11g		1		The worst case is ANT. A TX	
802.11n(HT20)		2		ANT. A+ ANT. B	
802.11n(HT40)		2		ANT. A+ ANT. B	
Antenna	Brand	Model Name		Type	Antenna Gain(dBi)
ANT. A	N/A	N/A		Dipole	2
ANT. B	N/A	N/A		Dipole	2

Note:  
For MIMO mode: Directional Gain=ANT. Gain+10\*LOG(N<sub>ANT</sub>) =5.01dBi  
2.4G working with 802.11n(HT20/HT40) has MIMO mode.

## 1.3 Block Diagram Showing the Configuration of System Tested

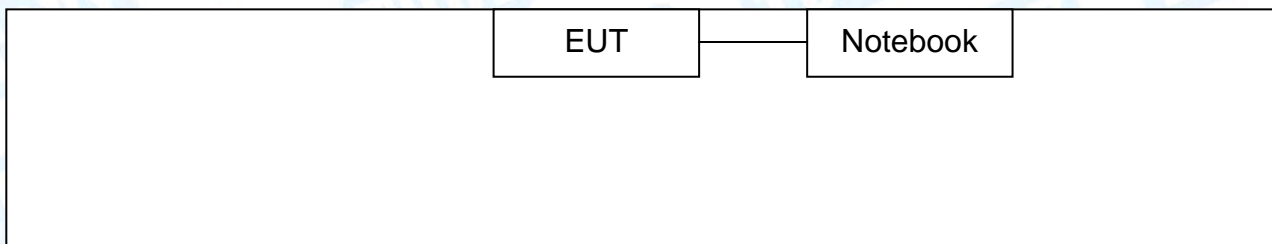

## 1.4 Description of Support Units

Name	Model	S/N	Manufacturer	Used “√”
Notebook	161301-CN	15987/00203076	Xiaomi	√
Notebook	T450s	-----	Thinkpad	√

### 1.5 Description of Test Mode

To investigate the maximum EMI emission characteristics generates from EUT, the test system was pre-scanning tested base on the consideration of following EUT operation mode or test configuration mode which possible have effect on EMI emission level. Each of these EUT operation mode(s) or test configuration mode(s) mentioned follow was evaluated respectively.

For Conducted Emission Test	
Final Test Mode	Description
Mode 1	Charging with TX B Mode Channel 01
For Radiated and RF Conducted Test	
Final Test Mode	Description
Mode 2	TX Mode B Mode Channel 01/06/11
Mode 3	TX Mode G Mode Channel 01/06/11
Mode 4	TX Mode N(HT20) Mode Channel 01/06/11
Mode 5	TX Mode N(HT40) Mode Channel 03/06/09

**Note:**

- (1) For all test, we have verified the construction and function in typical operation. And all the test modes were carried out with the EUT in transmitting operation in maximum power with all kinds of data rate.

According to ANSI C63.10 standards, the measurements are performed at the highest, Middle, lowest available channels, and the worst case data rate as follows:

- 802.11b Mode: CCK
- 802.11g Mode: OFDM
- 802.11n (HT20) Mode: MCS 0
- 802.11n (HT40) Mode: MCS 0

- (2) During the testing procedure, the continuously transmitting with the maximum power mode was programmed by the customer.
- (3) The EUT is considered a portable device; in normal use it was positioned on X-plane. The worst case was found positioned on X-plane. Therefore only the test data of this X-plane was used for radiated emission measurement test.

## 1.6 Description of Test Software Setting

During testing channel & Power controlling software provided by the customer was used to control the operating channel as well as the output power level. The RF output power selection is for the setting of RF output power expected by the customer and is going to be fixed on the firmware of the final end product power parameters of WLAN.

<b>Test Software: MPTOOL</b>				
<b>Test Mode:</b> Continuously transmitting				
<b>Mode</b>	<b>Data Rate</b>	<b>Channel</b>	<b>Parameters</b>	
			<b>Antenna A</b>	<b>Antenna B</b>
<b>802.11b</b>	CCK/ 1Mbps	01	24	13
	CCK/ 1Mbps	06	22	13
	CCK/ 1Mbps	11	22	17
<b>802.11g</b>	OFDM/ 6Mbps	01	22	13
	OFDM/ 6Mbps	06	22	12
	OFDM/ 6Mbps	11	22	12
<b>802.11n(HT20)</b>	MCS 0	01	18	10
	MCS 0	06	18	10
	MCS 0	11	18	10
<b>802.11n(HT40)</b>	MCS 0	03	20	10
	MCS 0	06	20	10
	MCS 0	09	20	10



## 1.7 Measurement Uncertainty

The reported uncertainty of measurement  $y \pm U$ , where expanded uncertainty  $U$  is based on a standard uncertainty multiplied by a coverage factor of  $k=2$ , providing a level of confidence of approximately 95 %.

Test Item	Parameters	Expanded Uncertainty ( $U_{Lab}$ )
Conducted Emission	Level Accuracy: 9kHz~150kHz 150kHz to 30MHz	$\pm 3.50$ dB $\pm 3.10$ dB
Radiated Emission	Level Accuracy: 9kHz to 30 MHz	$\pm 4.60$ dB
Radiated Emission	Level Accuracy: 30MHz to 1000 MHz	$\pm 4.50$ dB
Radiated Emission	Level Accuracy: Above 1000MHz	$\pm 4.20$ dB

## 1.8 Test Facility

The testing report were performed by the Shenzhen Toby Technology Co., Ltd., in their facilities located at 1/F.,Building 6, Rundongsheng Industrial Zone, Longzhu, Xixiang, Bao'an District, Shenzhen, Guangdong, China. At the time of testing, the following bodies accredited the Laboratory:

### **CNAS (L5813)**

The Laboratory has been accredited by CNAS to ISO/IEC 17025: 2017 General Requirements for the Competence of Testing and Calibration Laboratories for the competence in the field of testing. And the Registration No.: CNAS L5813.

### **A2LA Certificate No.: 4750.01**

The laboratory has been accredited by American Association for Laboratory Accreditation(A2LA) to ISO/IEC 17025: 2017 General Requirements for the Competence of Testing and Calibration Laboratories for the technical competence in the field of Electrical Testing. And the A2LA Certificate No.: 4750.01.FCC Accredited Test Site Number: 854351. Designation Number: CN1223.

### **IC Registration No.: (11950A)**

The Laboratory has been registered by Certification and Engineering Bureau of Industry Canada for radio equipment testing. The site registration: Site# 11950A.

## 2. Test Summary

FCC Part 15, Subpart C 15.247				
Standard Section	Test Item	Test Sample(s)	Judgment	Remark
15.203	Antenna Requirement	20210402-14-2#	PASS	N/A
15.207(a)	Conducted Emission	20210402-14-1#	PASS	N/A
15.205&15.247(d)	Band-Edge & Unwanted Emissions into Restricted Frequency	20210402-14-2#	PASS	N/A
15.247(a)(2)	6dB Bandwidth	20210402-14-2#	PASS	N/A
15.247(b)(3)	Conducted Max Output Power	20210402-14-2#	PASS	N/A
15.247(e)	Power Spectral Density	20210402-14-2#	PASS	N/A
15.205, 15.209&15.247(d)	Transmitter Radiated Spurious & Unwanted Emissions into Restricted Frequency	20210402-14-1# 20210402-14-2#	PASS	N/A

**Note:** “/” for no requirement for this test item.  
N/A is an abbreviation for Not Applicable.

## 3. Test Software

Test Item	Test Software	Manufacturer	Version No.
Conducted Emission	EZ-EMC	EZ	CDI-03A2
Radiation Emission	EZ-EMC	EZ	FA-03A2RE
RF Conducted Measurement	MTS-8310	MWRfTest	V2.0.0.0

## 4. Test Equipment

<b>Conducted Emission Test</b>					
<b>Equipment</b>	<b>Manufacturer</b>	<b>Model No.</b>	<b>Serial No.</b>	<b>Last Cal.</b>	<b>Cal. Due Date</b>
EMI Test Receiver	Rohde & Schwarz	ESCI	100321	Jul. 06, 2020	Jul. 05, 2021
RF Switching Unit	Compliance Direction Systems Inc	RSU-A4	34403	Jul. 06, 2020	Jul. 05, 2021
AMN	SCHWARZBECK	NNBL 8226-2	8226-2/164	Jul. 06, 2020	Jul. 05, 2021
LISN	Rohde & Schwarz	ENV216	101131	Jul. 06, 2020	Jul. 05, 2021
<b>Radiation Emission Test</b>					
<b>Equipment</b>	<b>Manufacturer</b>	<b>Model No.</b>	<b>Serial No.</b>	<b>Last Cal.</b>	<b>Cal. Due Date</b>
Spectrum Analyzer	Agilent	E4407B	MY45106456	Jul. 06, 2020	Jul. 05, 2021
EMI Test Receiver	Rohde & Schwarz	ESPI	100010/007	Jul. 06, 2020	Jul. 05, 2021
Spectrum Analyzer	Rohde & Schwarz	FSV40-N	102197	Jul. 06, 2020	Jul. 05, 2021
Bilog Antenna	ETS-LINDGREN	3142E	00117537	Mar.01, 2020	Feb. 28, 2022
Horn Antenna	ETS-LINDGREN	3117	00143207	Mar.01, 2020	Feb. 28, 2022
Horn Antenna	ETS-LINDGREN	BBHA 9170	BBHA9170582	Mar.01, 2020	Feb. 28, 2022
Loop Antenna	SCHWARZBECK	FMZB 1519 B	1519B-059	Jul. 07, 2020	Jul. 06, 2021
Pre-amplifier	Sonoma	310N	185903	Feb. 25, 2021	Feb. 24, 2022
Pre-amplifier	HP	8449B	3008A00849	Feb. 25, 2021	Feb. 24, 2022
Pre-amplifier	SKET	LNPA_1840G-50	SK201904032	Feb. 25, 2021	Feb. 24, 2022
Cable	HUBER+SUHNER	100	SUCOFLEX	Feb. 25, 2021	Feb. 24, 2022
Positioning Controller	ETS-LINDGREN	2090	N/A	N/A	N/A
<b>Antenna Conducted Emission</b>					
<b>Equipment</b>	<b>Manufacturer</b>	<b>Model No.</b>	<b>Serial No.</b>	<b>Last Cal.</b>	<b>Cal. Due Date</b>
Spectrum Analyzer	Agilent	E4407B	MY45106456	Jul. 06, 2020	Jul. 05, 2021
Spectrum Analyzer	Rohde & Schwarz	ESPI	100010/007	Jul. 06, 2020	Jul. 05, 2021
MXA Signal Analyzer	Agilent	N9020A	MY49100060	Sep. 11, 2020	Sep. 10, 2021
Vector Signal Generator	Agilent	N5182A	MY50141294	Sep. 11, 2020	Sep. 10, 2021
Analog Signal Generator	Agilent	N5181A	MY50141953	Sep. 11, 2020	Sep. 10, 2021
RF Power Sensor	DARE!! Instruments	RadiPowerRPR3006W	17100015SNO26	Sep. 11, 2020	Sep. 10, 2021
	DARE!! Instruments	RadiPowerRPR3006W	17100015SNO29	Sep. 11, 2020	Sep. 10, 2021
	DARE!! Instruments	RadiPowerRPR3006W	17100015SNO31	Sep. 11, 2020	Sep. 10, 2021
	DARE!! Instruments	RadiPowerRPR3006W	17100015SNO33	Sep. 11, 2020	Sep. 10, 2021

## 5. Conducted Emission Test

### 5.1 Test Standard and Limit

#### 5.1.1 Test Standard

FCC Part 15.207

#### 5.1.2 Test Limit

**Conducted Emission Test Limit**

Frequency	Maximum RF Line Voltage (dB $\mu$ V)	
	Quasi-peak Level	Average Level
150kHz~500kHz	66 ~ 56 *	56 ~ 46 *
500kHz~5MHz	56	46
5MHz~30MHz	60	50

Notes:

(1) \*Decreasing linearly with logarithm of the frequency.

(2) The lower limit shall apply at the transition frequencies.

(3) The limit decrease in line with the logarithm of the frequency in the range of 0.15 to 0.50MHz.

### 5.2 Test Setup

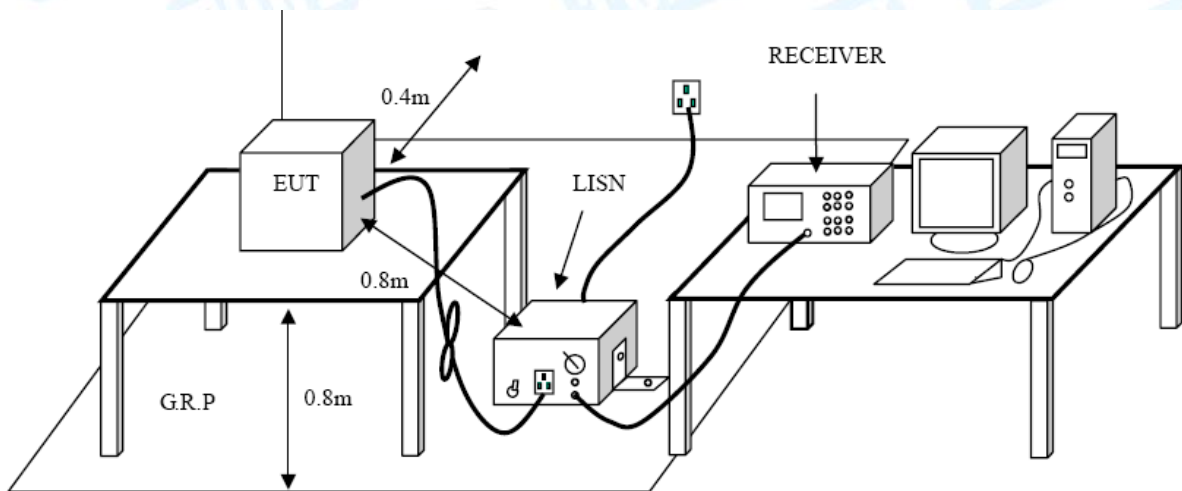

### 5.3 Test Procedure

- (1) The EUT was placed 0.8 meters from the horizontal ground plane with EUT being connected to the power mains through a line impedance stabilization network (LISN). All other support equipments powered from additional LISN(s). The LISN provide 50 Ohm/ 50uH of coupling impedance for the measuring instrument.
- (2) Interconnecting cables that hang closer than 40 cm to the ground plane shall be folded back and forth in the center forming a bundle 30 to 40 cm long.
- (3) I/O cables that are not connected to a peripheral shall be bundled in the center. The end of the cable may be terminated, if required, using the correct terminating impedance. The overall length shall not exceed 1 m.
- (4) LISN at least 80 cm from nearest part of EUT chassis.
- (5) The bandwidth of EMI test receiver is set at 9kHz, and the test frequency band is from 0.15MHz to 30MHz.

### 5.4 Deviation From Test Standard

No deviation

### 5.5 EUT Operating Mode

Please refer to the description of test mode.

### 5.6 Test Data

Please refer to the Attachment A.

## 6. Radiated Emission Test

### 6.1 Test Standard and Limit

#### 6.1.1 Test Standard

FCC Part 15.209

#### 6.1.2 Test Limit

#### General field strength limits at frequencies above 30 MHz

Frequency (MHz)	Field strength ( $\mu\text{V}/\text{m}$ at 3 m)	Measurement Distance (meters)
30~88	100	3
88~216	150	3
216~960	200	3
Above 960	500	3

#### General field strength limits at frequencies Above 1000MHz

Frequency (MHz)	Distance of 3m (dBuV/m)	
	Peak	Average
Above 1000	74	54

**Note:**

(1) The tighter limit applies at the band edges.

(2) Emission Level(dBuV/m)=20log Emission Level(uV/m)

#### General field strength limits at frequencies Below 30MHz

Frequency (MHz)	Field Strength ( $\mu\text{A}/\text{m}$ )	Field Strength (microvolt/meter)	Measurement Distance (meters)
0.009~0.490	6.37/F (F in kHz)	2400/F(KHz)	300
0.490~1.705	63.7/F (F in kHz)	24000/F(KHz)	30
1.705~30.0	0.08	30	30

**Note 1:** The emission limits for the ranges 9-90 kHz and 110-490 kHz are based on measurements employing a linear average detector.

6.2 Test Setup

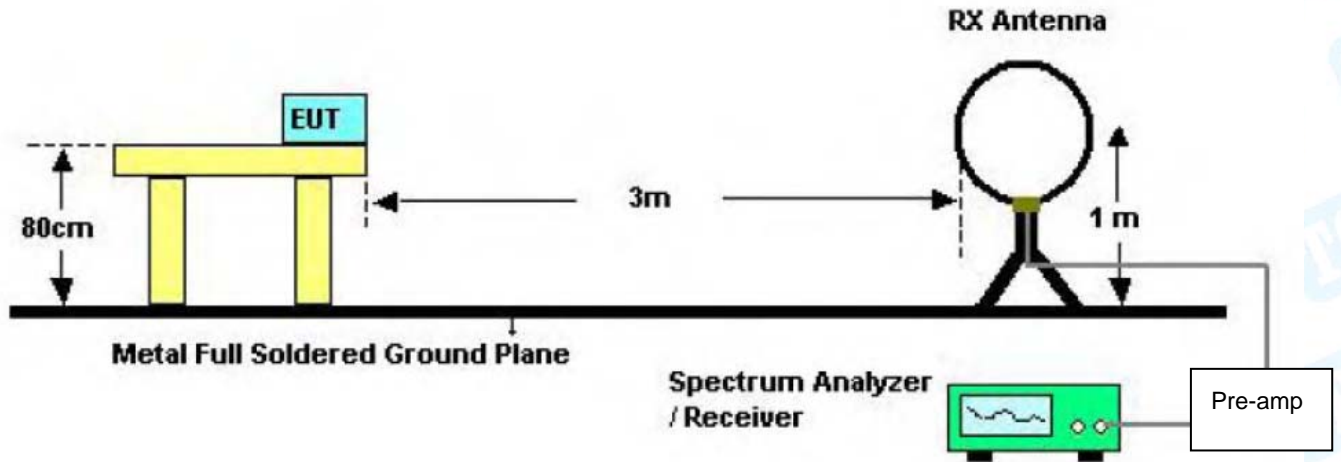

Below 30MHz Test Setup

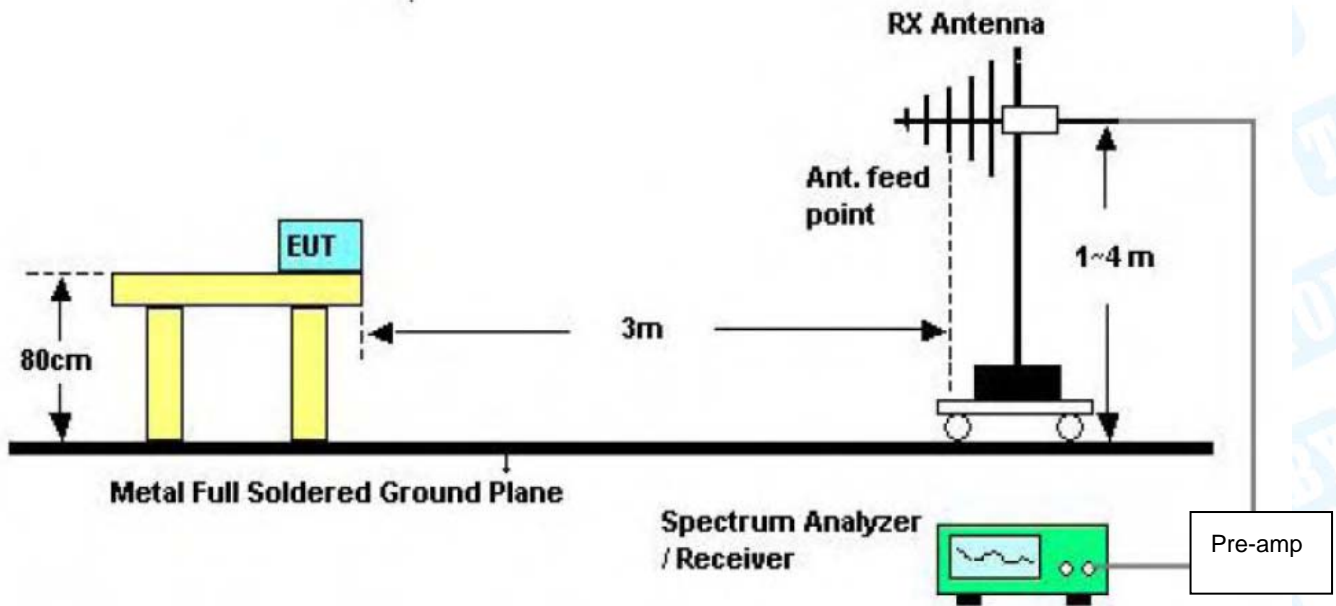

Below 1000MHz Test Setup

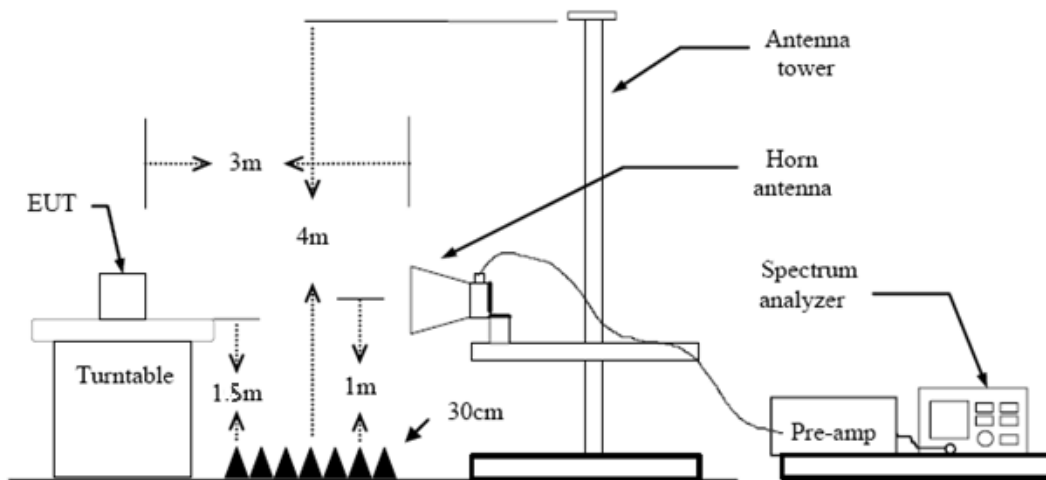

Above 1GHz Test Setup

### 6.3 Test Procedure

- (1) Measurements at frequency above 1GHz. The EUT was placed on a rotating 1.5m high above the ground. RF absorbers covered the ground plane with a minimum area of 3.0m by 3.0m between the EUT and measurement receiver antenna. The RF absorber shall not exceed 30cm in high above the conducting floor. The table was rotated 360 degrees to determine the position of the highest radiation.
- (2) Measurements at frequency Below 1GHz. The EUT was placed on a rotating 0.8m high above the ground. RF absorbers covered the ground plane with a minimum area of 3.0m by 3.0m between the EUT and measurement receiver antenna. The RF absorber shall not exceed 30cm in high above the conducting floor. The table was rotated 360 degrees to determine the position of the highest radiation.
- (3) The Test antenna shall vary between 1m and 4m, Both Horizontal and Vertical antenna are set to make measurement.
- (4) The initial step in collecting conducted emission data is a spectrum analyzer peak detector mode pre-scanning the measurement frequency range. Significant peaks are then marked and then Quasi Peak detector mode re-measured.
- (5) If the Peak Mode measured value compliance with and lower than Quasi Peak Mode Limit Bellow 1 GHz, the EUT shall be deemed to meet QP Limits and then no additional QP Mode measurement performed. But the Peak Value and average value both need to comply with applicable limit above 1 GHz.
- (6) Testing frequency range below 1GHz the measuring instrument use VBW=120 kHz with Quasi-peak detection.
- (7) Testing frequency range above 1GHz the measuring instrument use RBW=1 MHz and VBW=3 MHz with Peak Detector for Peak Values, and use RBW=1 MHz and VBW=10 Hz with Peak Detector for Average Values.
- (8) For the actual test configuration, please see the test setup photo.



#### 6.4 Deviation From Test Standard

No deviation

#### 6.5 EUT Operating Condition

The Equipment Under Test was set to Continual Transmitting in maximum power.

#### 6.6 Test Data

Remark: During testing above 1GHz the measuring instrument use RBW=1 MHz and VBW=3 MHz with Peak Detector for Peak Values, and use RBW=1 MHz and VBW=10 Hz with Peak Detector for Average Values.

Please refer to the Attachment B.

## 7. Restricted Bands Requirement

### 7.1 Test Standard and Limit

#### 7.1.1 Test Standard

FCC Part 15.247(d)  
FCC Part 15.209  
FCC Part 15.205

#### 7.1.2 Test Limit

Restricted Frequency Band (MHz)	Distance of 3m (dBuV/m)	
	Peak	Average
2310 ~2390	74	54
2483.5 ~2500	74	54

### 7.2 Test Setup

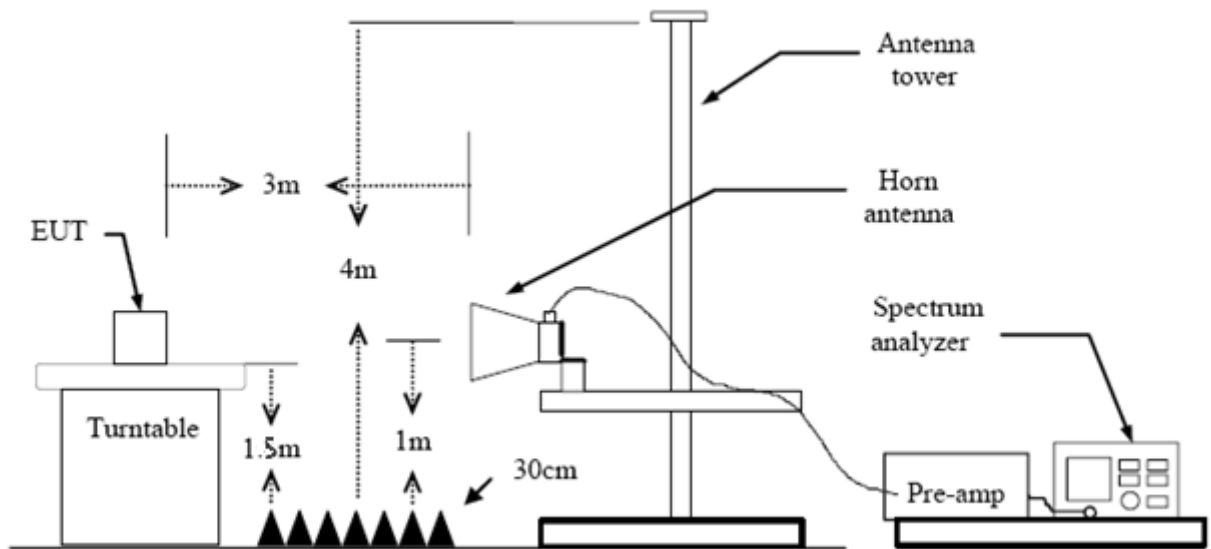

### 7.3 Test Procedure

- (1) The measuring distance of 3m shall be used for measurements at frequency Below 1GHz and above 1 GHz. The EUT was placed on a rotating 0.8m high above ground, the table was rotated 360 degrees to determine the position of the highest radiation.
- (2) Measurements at frequency above 1GHz. The EUT was placed on a rotating 1.5m high above the ground. RF absorbers covered the ground plane with a minimum area of 3.0m by 3.0m between the EUT and measurement receiver antenna. The RF absorber shall not exceed 30cm in high above the conducting floor. The table was rotated 360 degrees to determine the position of the highest radiation.
- (3) The Test antenna shall vary between 1m and 4m, Both Horizontal and Vertical antenna are set to make measurement.
- (4) The initial step in collecting conducted emission data is a spectrum analyzer peak detector mode pre-scanning the measurement frequency range. Significant peaks are then marked and then Quasi Peak detector mode re-measured.
- (5) If the Peak Mode measured value compliance with and lower than Quasi Peak Mode Limit Bellow 1 GHz, the EUT shall be deemed to meet QP Limits and then no additional QP Mode measurement performed. But the Peak Value and average value both need to comply with applicable limit above 1 GHz.
- (6) Testing frequency range below 1GHz the measuring instrument use VBW=120 kHz with Quasi-peak detection.
- (7) Testing frequency range above 1GHz the measuring instrument use RBW=1 MHz and VBW=3 MHz with Peak Detector for Peak Values, and use RBW=1 MHz and VBW=10 Hz with Peak Detector for Average Values.
- (8) For the actual test configuration, please see the test setup photo.

### 7.4 Deviation From Test Standard

No deviation

### 7.5 EUT Operating Condition

The Equipment Under Test was set to Continual Transmitting in maximum power.

### 7.6 Test Data

Please refer to the Attachment C.

## 8. Bandwidth Test

### 8.1 Test Standard and Limit

- 8.1.1 Test Standard  
FCC Part 15.247 (a)(2)
- 8.1.2 Test Limit

Test Item	Limit	Frequency Range(MHz)
Bandwidth	$\geq 500$ KHz (6dB bandwidth)	2400~2483.5

### 8.2 Test Setup

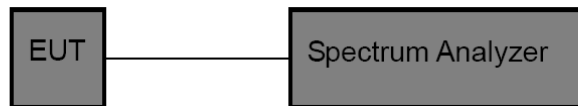

### 8.3 Test Procedure

- The transmitter shall be operated at its maximum carrier power measured under normal test conditions.
- The span of the spectrum analyzer shall be set large enough to capture all products of the modulation process, including the emission skirts, around the carrier frequency, but small enough to avoid having other emissions (e.g. on adjacent channels) within the span.
- The detector of the spectrum analyzer shall be set to “Sample”. However, a peak, or peak hold, may be used in place of the sampling detector since this usually produces a wider bandwidth than the actual bandwidth (worst-case measurement). Use of a peak hold (or “Max Hold”) may be necessary to determine the occupied / x dB bandwidth if the device is not transmitting continuously.
- The resolution bandwidth (RBW) shall be in the range of 1% to 5% of the actual occupied / x dB bandwidth and the video bandwidth (VBW) shall not be smaller than three times the RBW value. Video averaging is not permitted.

### 8.4 Deviation From Test Standard

No deviation

### 8.5 EUT Operating Condition

The EUT was set to continuously transmitting in each mode and low, Middle and high channel for the test.

### 8.6 Test Data

Please refer to the Attachment D.

## 9. Peak Output Power

### 9.1 Test Standard and Limit

#### 9.1.1 Test Standard

FCC Part 15.247 (b)

#### 9.1.2 Test Limit

Test Item	Limit	Frequency Range(MHz)
Peak Output Power	not exceed 1 W or 30dBm	2400~2483.5

### 9.2 Test Setup

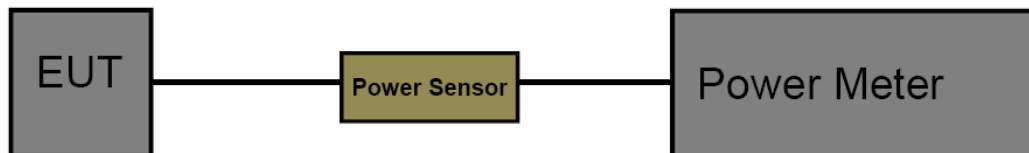

### 9.3 Test Procedure

The measurement is according to section 9.1.2 of KDB 558074 D01 v05r02.

The EUT was connected to RF power meter via a broadband power sensor as show the block above. The power sensor video bandwidth is greater than or equal to the DTS bandwidth of the equipment.

### 9.4 Deviation From Test Standard

No deviation

### 9.5 EUT Operating Condition

The EUT was set to continuously transmitting in the max power during the test.

### 9.6 Test Data

Please refer to the Attachment E.

## 10. Power Spectral Density Test

### 10.1 Test Standard and Limit

#### 10.1.1 Test Standard

FCC Part 15.247 (e)

#### 10.1.2 Test Limit

Test Item	Limit	Frequency Range(MHz)
Power Spectral Density	8dBm(in any 3 kHz)	2400~2483.5

### 10.2 Test Setup

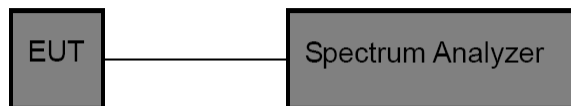

### 10.3 Test Procedure

The EUT was directly connected to the Spectrum Analyzer and antenna output port as show in the block diagram above. The measurement according to section 10.2 of KDB 558074 D01 D01 v05r02.

- (1) The EUT was directly connected to the spectrum analyzer and antenna output port as show in the block diagram above.
- (2) Set analyser centre frequency to DTS channel centre frequency.
- (3) Set the span to 1.5 times the DTS bandwidth.
- (4) Set the RBW to: 3 kHz
- (5) Set the VBW to: 10 kHz
- (6) Detector: peak
- (7) Sweep time: auto
- (8) Allow trace to fully stabilize. Then use the peak marker function to determine the maximum amplitude level.

### 10.4 Deviation From Test Standard

No deviation

### 10.5 EUT Operating Condition

The EUT was set to continuously transmitting in each mode and low, Middle and high channel for the test.

### 10.6 Test Data

Please refer to the Attachment F.

## 11. Antenna Requirement

### 11.1 Standard Requirement

#### 11.1.1 Standard

FCC Part 15.203

#### 11.1.2 Requirement

An intentional radiator shall be designed to ensure that no antenna other than that furnished by the responsible party shall be used with the device. The use of a permanently attached antenna or of an antenna that uses a unique coupling to the intentional radiator shall be considered sufficient to comply with the provisions of this Section. The manufacturer may design the unit so that a broken antenna can be replaced by the user, but the use of a standard antenna jack or electrical connector is prohibited.

### 11.2 Deviation From Test Standard

No deviation

### 11.3 Antenna Connected Construction

The gains of the antenna used for transmitting is 2dBi, and the antenna de-signed with unique connector antenna and no consideration of replacement. Please see the EUT photo for details.

#### Result

The EUT antenna is a Dipole Antenna. It complies with the standard requirement.

Antenna Type
<input checked="" type="checkbox"/> Permanent attached antenna
<input type="checkbox"/> Unique connector antenna
<input type="checkbox"/> Professional installation antenna

## Attachment A-- Conducted Emission Test Data

Remark: All channels have been tested and Shows only the worst channels.

<b>Temperature:</b>	23.6°C	<b>Relative Humidity:</b>	43%
<b>Test Voltage:</b>	AC 120V/60Hz		
<b>Terminal:</b>	Line		
<b>Test Mode:</b>	Mode 1 (TX B Mode Channel 01)		
<b>Remark:</b>	Only worst case is reported		

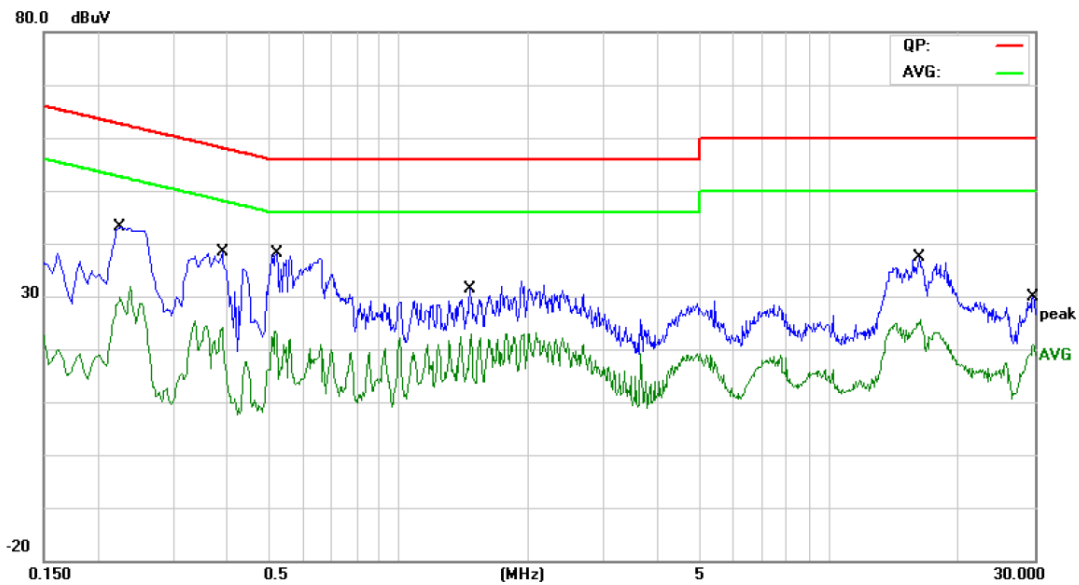

No.	Mk.	Freq. MHz	Reading Level dBuV	Correct Factor dB	Measure- ment dBuV	Limit dBuV	Over dB	Detector
1	*	0.2260	31.71	9.70	41.41	62.59	-21.18	QP
2		0.2260	16.97	9.70	26.67	52.59	-25.92	AVG
3		0.3899	22.28	9.70	31.98	58.06	-26.08	QP
4		0.3899	5.22	9.70	14.92	48.06	-33.14	AVG
5		0.5220	23.11	9.70	32.81	56.00	-23.19	QP
6		0.5220	5.92	9.70	15.62	46.00	-30.38	AVG
7		1.4700	11.87	9.75	21.62	56.00	-34.38	QP
8		1.4700	3.71	9.75	13.46	46.00	-32.54	AVG
9		16.1619	17.68	10.00	27.68	60.00	-32.32	QP
10		16.1619	11.55	10.00	21.55	50.00	-28.45	AVG
11		29.8380	13.60	10.08	23.68	60.00	-36.32	QP
12		29.8380	8.14	10.08	18.22	50.00	-31.78	AVG

**Remark:**

1. Corr. Factor (dB) = LISN Factor (dB) + Cable Loss (dB)

2. Margin (dB) = QuasiPeak/Average (dBuV) - Limit (dBuV)



<b>Temperature:</b>	23.6°C	<b>Relative Humidity:</b>	43%
<b>Test Voltage:</b>	AC 120V/60Hz		
<b>Terminal:</b>	Neutral		
<b>Test Mode:</b>	Mode 1(TX B Mode Channel 01)		
<b>Remark:</b>	Only worst case is reported		

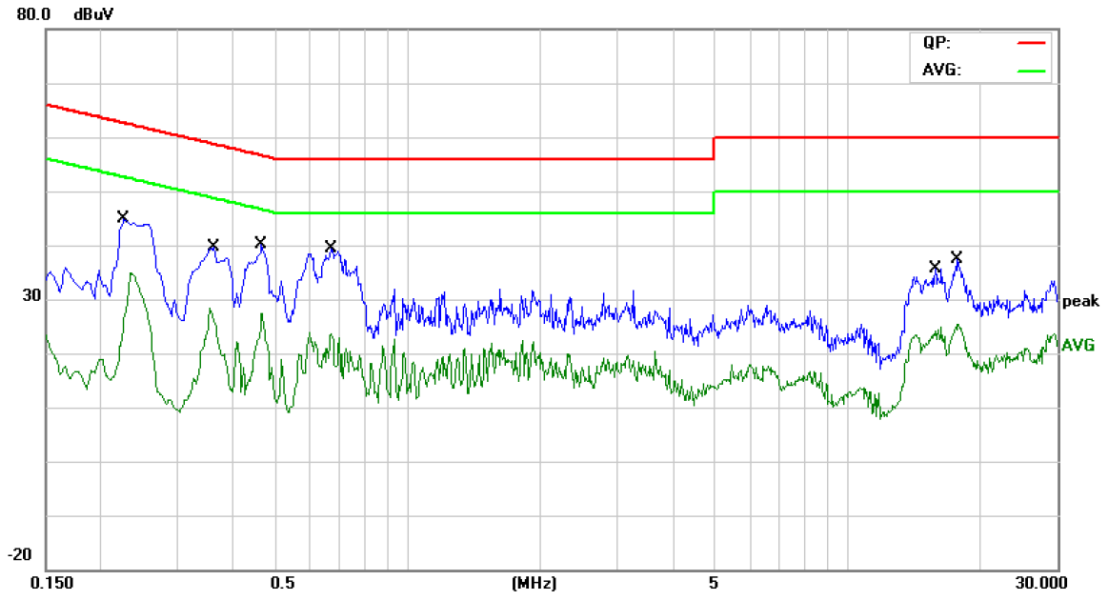

No.	Mk.	Freq. MHz	Reading Level dBuV	Correct Factor dB	Measure- ment dBuV	Limit dBuV	Over dB	Detector
1	*	0.2260	33.19	9.80	42.99	62.59	-19.60	QP
2		0.2260	18.42	9.80	28.22	52.59	-24.37	AVG
3		0.3620	28.01	9.80	37.81	58.68	-20.87	QP
4		0.3620	14.97	9.80	24.77	48.68	-23.91	AVG
5		0.4660	26.70	9.80	36.50	56.58	-20.08	QP
6		0.4660	16.35	9.80	26.15	46.58	-20.43	AVG
7		0.6700	25.03	9.80	34.83	56.00	-21.17	QP
8		0.6700	10.36	9.80	20.16	46.00	-25.84	AVG
9		15.8540	18.20	10.00	28.20	60.00	-31.80	QP
10		15.8540	12.30	10.00	22.30	50.00	-27.70	AVG
11		17.8380	19.71	10.00	29.71	60.00	-30.29	QP
12		17.8380	13.62	10.00	23.62	50.00	-26.38	AVG

**Remark:**

1. Corr. Factor (dB) = LISN Factor (dB) + Cable Loss (dB)
2. Margin (dB) = QuasiPeak/Average (dBuV) - Limit (dBuV)

## Attachment B-- Radiated Emission Test Data

### 9KHz~30MHz

From 9KHz to 30MHz: Conclusion: PASS

Note: The amplitude of spurious emissions which are attenuated by more than 20dB below the permissible value has no need to be reported.

### 30MHz~1GHz

<b>Temperature:</b>	23.6°C	<b>Relative Humidity:</b>	43%
<b>Test Voltage:</b>	DC 5V		
<b>Ant. Pol.</b>	Horizontal		
<b>Test Mode:</b>	TX B Mode 2412MHz		
<b>Remark:</b>	Only worst case is reported.		

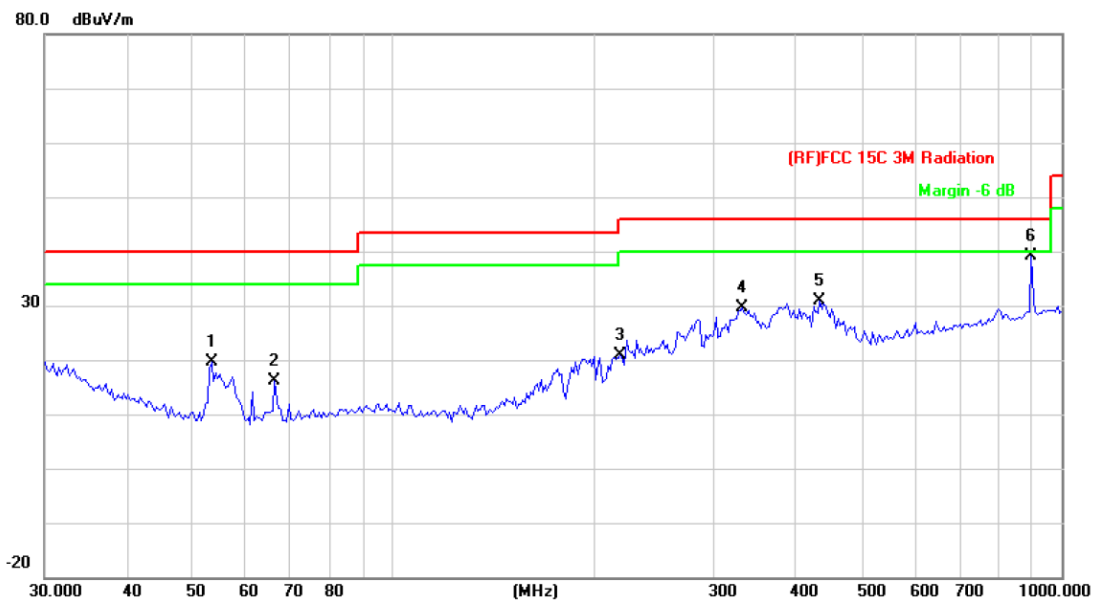

No.	Mk.	Freq. MHz	Reading Level dBuV	Correct Factor dB/m	Measure- ment dBuV/m	Limit dBuV/m	Over dB	Detector
1		53.3179	43.14	-23.44	19.70	40.00	-20.30	peak
2		66.2662	39.89	-23.70	16.19	40.00	-23.81	peak
3		218.3085	39.85	-18.95	20.90	46.00	-25.10	peak
4		332.5187	44.73	-15.21	29.52	46.00	-16.48	peak
5		434.0651	43.02	-12.04	30.98	46.00	-15.02	peak
6	*	900.1474	43.33	-4.24	39.09	46.00	-6.91	peak

\*:Maximum data    x:Over limit    !:over margin

**Remark:**

1. Corr. = Antenna Factor (dB/m) + Cable Loss (dB)
2. QuasiPeak (dBμV/m)= Corr. (dB/m)+ Read Level (dBμV)
3. Margin (dB) = QuasiPeak (dBμV/m)-Limit QPK(dBμV/m)

Temperature:	23.6°C	Relative Humidity:	43%
Test Voltage:	DC 5V		
Ant. Pol.	Vertical		
Test Mode:	TX B Mode 2412MHz		
Remark:	Only worst case is reported.		

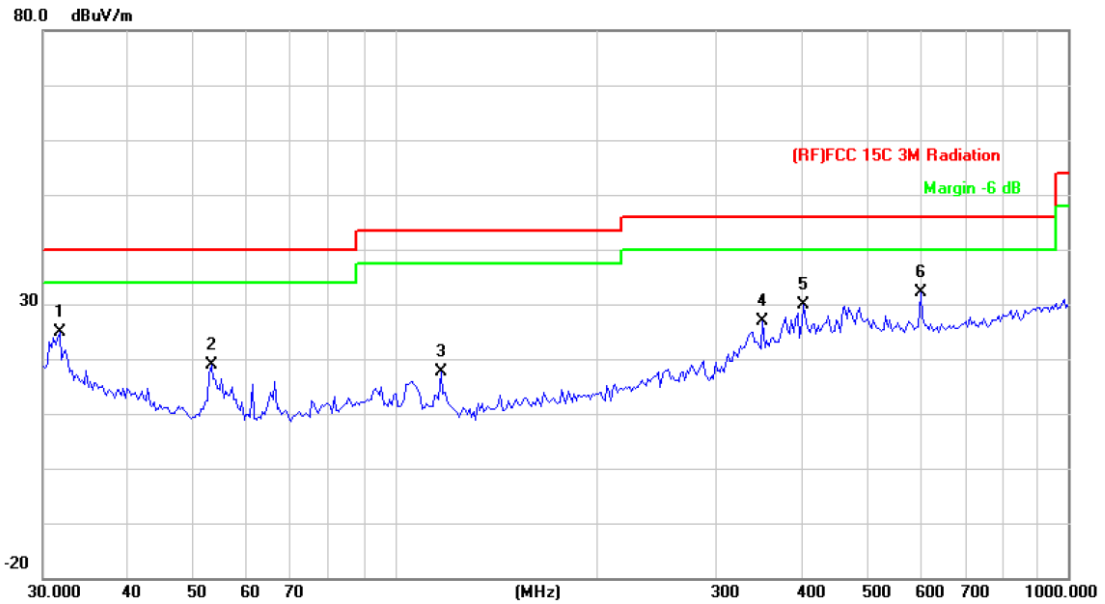

No.	Mk.	Freq. MHz	Reading Level dBuV	Correct Factor dB/m	Measure- ment dBuV/m	Limit dBuV/m	Over dB	Detector
1		31.7313	39.14	-14.25	24.89	40.00	-15.11	peak
2		53.3179	42.38	-23.44	18.94	40.00	-21.06	peak
3		116.9495	39.81	-22.21	17.60	43.50	-25.90	peak
4		351.7079	41.33	-14.55	26.78	46.00	-19.22	peak
5		404.6665	42.24	-12.25	29.99	46.00	-16.01	peak
6	*	603.5392	40.41	-8.28	32.13	46.00	-13.87	peak

\*:Maximum data    x:Over limit    !:over margin

**Remark:**

1. Corr. = Antenna Factor (dB/m) + Cable Loss (dB)
2. QuasiPeak (dBμV/m)= Corr. (dB/m)+ Read Level (dBμV)
3. Margin (dB) = QuasiPeak (dBμV/m)-Limit QPK(dBμV/m)

**Above 1GHz**

<b>Temperature:</b>	24.1°C	<b>Relative Humidity:</b>	41%
<b>Test Voltage:</b>	DC 5V		
<b>Ant. Pol.</b>	Horizontal		
<b>Test Mode:</b>	TX B Mode 2412MHz Antenna A		

No.	Mk.	Freq.	Reading Level	Correct Factor	Measurement	Limit	Over	Detector
		MHz	dBuV	dB	dBuV/m	dBuV/m	dB	
1		4823.800	45.64	13.16	58.80	74.00	-15.20	peak
2	*	4824.500	36.27	13.16	49.43	54.00	-4.57	AVG

**Remark:**

1. Corr. = Antenna Factor (dB/m) + Cable Loss (dB)
2. Peak/AVG (dBμV/m)= Corr. (dB/m)+ Read Level (dBμV)
3. Margin (dB) = Peak/AVG (dBμV/m)-Limit PK/AVG(dBμV/m)
4. The tests evaluated1-26.5GHz,The testing has been conformed to the 10th harmonic of the highest fundamental frequency.
5. No report for the emission which more than 20dB below the prescribed limit.

<b>Temperature:</b>	24.1°C	<b>Relative Humidity:</b>	41%
<b>Test Voltage:</b>	DC 5V		
<b>Ant. Pol.</b>	Vertical		
<b>Test Mode:</b>	TX B Mode 2412MHz Antenna A		

No.	Mk.	Freq.	Reading Level	Correct Factor	Measurement	Limit	Over	Detector
		MHz	dBuV	dB	dBuV/m	dBuV/m	dB	
1	*	4823.540	32.24	13.16	45.40	54.00	-8.60	AVG
2		4824.420	45.26	13.16	58.42	74.00	-15.58	peak

**Remark:**

1. Corr. = Antenna Factor (dB/m) + Cable Loss (dB)
2. Peak/AVG (dBμV/m)= Corr. (dB/m)+ Read Level (dBμV)
3. Margin (dB) = Peak/AVG (dBμV/m)-Limit PK/AVG(dBμV/m)
4. The tests evaluated1-26.5GHz,The testing has been conformed to the 10th harmonic of the highest fundamental frequency.
5. No report for the emission which more than 20dB below the prescribed limit.

<b>Temperature:</b>	24.1°C	<b>Relative Humidity:</b>	41%					
<b>Test Voltage:</b>	DC 5V							
<b>Ant. Pol.</b>	Horizontal							
<b>Test Mode:</b>	TX B Mode 2437MHz Antenna A							
No.	Mk.	Freq.	Reading Level	Correct Factor	Measurement	Limit	Over	Detector
		MHz	dBuV	dB	dBuV/m	dBuV/m	dB	
1		4874.020	40.73	13.53	54.26	74.00	-19.74	peak
2	*	4874.400	31.59	13.53	45.12	54.00	-8.88	AVG
<b>Remark:</b> 1. Corr. = Antenna Factor (dB/m) + Cable Loss (dB) 2. Peak/AVG (dBμV/m)= Corr. (dB/m)+ Read Level (dBμV) 3. Margin (dB) = Peak/AVG (dBμV/m)-Limit PK/AVG(dBμV/m) 4. The tests evaluated1-26.5GHz,The testing has been conformed to the 10th harmonic of the highest fundamental frequency. 5. No report for the emission which more than 20dB below the prescribed limit.								

<b>Temperature:</b>	24.1°C	<b>Relative Humidity:</b>	41%					
<b>Test Voltage:</b>	DC 5V							
<b>Ant. Pol.</b>	Vertical							
<b>Test Mode:</b>	TX B Mode 2437MHz Antenna A							
No.	Mk.	Freq.	Reading Level	Correct Factor	Measurement	Limit	Over	Detector
		MHz	dBuV	dB	dBuV/m	dBuV/m	dB	
1	*	4874.000	31.61	13.53	45.14	54.00	-8.86	AVG
2		4874.120	41.23	13.53	54.76	74.00	-19.24	peak
<b>Remark:</b> 1. Corr. = Antenna Factor (dB/m) + Cable Loss (dB) 2. Peak/AVG (dBμV/m)= Corr. (dB/m)+ Read Level (dBμV) 3. Margin (dB) = Peak/AVG (dBμV/m)-Limit PK/AVG(dBμV/m) 4. The tests evaluated1-26.5GHz,The testing has been conformed to the 10th harmonic of the highest fundamental frequency. 5. No report for the emission which more than 20dB below the prescribed limit.								

<b>Temperature:</b>	24.1°C	<b>Relative Humidity:</b>	41%				
<b>Test Voltage:</b>	DC 5V						
<b>Ant. Pol.</b>	Horizontal						
<b>Test Mode:</b>	TX B Mode 2462MHz Antenna A						
No.	Mk.	Freq.	Reading Level	Correct Factor	Measurement	Limit	Over
		MHz	dBuV	dB	dBuV/m	dBuV/m	dB
							Detector
1		4924.020	40.29	13.89	54.18	74.00	-19.82 peak
2	*	4924.400	30.97	13.89	44.86	54.00	-9.14 AVG
<b>Remark:</b>							
1. Corr. = Antenna Factor (dB/m) + Cable Loss (dB)							
2. Peak/AVG (dBμV/m)= Corr. (dB/m)+ Read Level (dBμV)							
3. Margin (dB) = Peak/AVG (dBμV/m)-Limit PK/AVG(dBμV/m)							
4. The tests evaluated1-26.5GHz,The testing has been conformed to the 10th harmonic of the highest fundamental frequency.							
5. No report for the emission which more than 20dB below the prescribed limit.							

<b>Temperature:</b>	24.1°C	<b>Relative Humidity:</b>	41%				
<b>Test Voltage:</b>	DC 5V						
<b>Ant. Pol.</b>	Vertical						
<b>Test Mode:</b>	TX B Mode 2462MHz Antenna A						
No.	Mk.	Freq.	Reading Level	Correct Factor	Measurement	Limit	Over
		MHz	dBuV	dB	dBuV/m	dBuV/m	dB
							Detector
1		4923.500	41.08	13.89	54.97	74.00	-19.03 peak
2	*	4924.020	30.57	13.89	44.46	54.00	-9.54 AVG
<b>Remark:</b>							
1. Corr. = Antenna Factor (dB/m) + Cable Loss (dB)							
2. Peak/AVG (dBμV/m)= Corr. (dB/m)+ Read Level (dBμV)							
3. Margin (dB) = Peak/AVG (dBμV/m)-Limit PK/AVG(dBμV/m)							
4. The tests evaluated1-26.5GHz,The testing has been conformed to the 10th harmonic of the highest fundamental frequency.							
5. No report for the emission which more than 20dB below the prescribed limit.							

<b>Temperature:</b>	24.1°C	<b>Relative Humidity:</b>	41%
<b>Test Voltage:</b>	DC 5V		
<b>Ant. Pol.</b>	Horizontal		
<b>Test Mode:</b>	TX G Mode 2412MHz Antenna A		

No.	Mk.	Freq.	Reading Level	Correct Factor	Measurement	Limit	Over	Detector
		MHz	dBuV	dB	dBuV/m	dBuV/m	dB	
1	*	4824.000	32.09	13.16	45.25	54.00	-8.75	AVG
2		4824.900	39.41	13.16	52.57	74.00	-21.43	peak

**Remark:**

1. Corr. = Antenna Factor (dB/m) + Cable Loss (dB)
2. Peak/AVG (dBμV/m)= Corr. (dB/m)+ Read Level (dBμV)
3. Margin (dB) = Peak/AVG (dBμV/m)-Limit PK/AVG(dBμV/m)
4. The tests evaluated1-26.5GHz,The testing has been conformed to the 10th harmonic of the highest fundamental frequency.
5. No report for the emission which more than 20dB below the prescribed limit.

<b>Temperature:</b>	24.1°C	<b>Relative Humidity:</b>	41%
<b>Test Voltage:</b>	DC 5V		
<b>Ant. Pol.</b>	Vertical		
<b>Test Mode:</b>	TX G Mode 2412MHz Antenna A		

No.	Mk.	Freq.	Reading Level	Correct Factor	Measurement	Limit	Over	Detector
		MHz	dBuV	dB	dBuV/m	dBuV/m	dB	
1	*	4824.440	29.42	13.16	42.58	54.00	-11.42	AVG
2		4824.500	39.83	13.16	52.99	74.00	-21.01	peak

**Remark:**

1. Corr. = Antenna Factor (dB/m) + Cable Loss (dB)
2. Peak/AVG (dBμV/m)= Corr. (dB/m)+ Read Level (dBμV)
3. Margin (dB) = Peak/AVG (dBμV/m)-Limit PK/AVG(dBμV/m)
4. The tests evaluated1-26.5GHz,The testing has been conformed to the 10th harmonic of the highest fundamental frequency.
5. No report for the emission which more than 20dB below the prescribed limit.

<b>Temperature:</b>	24.1°C	<b>Relative Humidity:</b>	41%
<b>Test Voltage:</b>	DC 5V		
<b>Ant. Pol.</b>	Horizontal		
<b>Test Mode:</b>	TX G Mode 2437MHz Antenna A		

No.	Mk.	Freq.	Reading Level	Correct Factor	Measurement	Limit	Over	Detector
		MHz	dBuV	dB	dBuV/m	dBuV/m	dB	
1	*	4872.000	29.33	13.51	42.84	54.00	-11.16	AVG
2		4873.000	37.50	13.52	51.02	74.00	-22.98	peak

**Remark:**

1. Corr. = Antenna Factor (dB/m) + Cable Loss (dB)
2. Peak/AVG (dBμV/m)= Corr. (dB/m)+ Read Level (dBμV)
3. Margin (dB) = Peak/AVG (dBμV/m)-Limit PK/AVG(dBμV/m)
4. The tests evaluated1-26.5GHz,The testing has been conformed to the 10th harmonic of the highest fundamental frequency.
5. No report for the emission which more than 20dB below the prescribed limit.

<b>Temperature:</b>	24.1°C	<b>Relative Humidity:</b>	41%
<b>Test Voltage:</b>	DC 5V		
<b>Ant. Pol.</b>	Vertical		
<b>Test Mode:</b>	TX G Mode 2437MHz Antenna A		

No.	Mk.	Freq.	Reading Level	Correct Factor	Measurement	Limit	Over	Detector
		MHz	dBuV	dB	dBuV/m	dBuV/m	dB	
1	*	4874.060	27.71	13.53	41.24	54.00	-12.76	AVG
2		4874.500	39.05	13.53	52.58	74.00	-21.42	peak

**Remark:**

1. Corr. = Antenna Factor (dB/m) + Cable Loss (dB)
2. Peak/AVG (dBμV/m)= Corr. (dB/m)+ Read Level (dBμV)
3. Margin (dB) = Peak/AVG (dBμV/m)-Limit PK/AVG(dBμV/m)
4. The tests evaluated1-26.5GHz,The testing has been conformed to the 10th harmonic of the highest fundamental frequency.
5. No report for the emission which more than 20dB below the prescribed limit.



<b>Temperature:</b>	24.1°C	<b>Relative Humidity:</b>	41%					
<b>Test Voltage:</b>	DC 5V							
<b>Ant. Pol.</b>	Horizontal							
<b>Test Mode:</b>	TX G Mode 2462MHz Antenna A							
No.	Mk.	Freq.	Reading Level	Correct Factor	Measurement	Limit	Over	
		MHz	dBuV	dB	dBuV/m	dBuV/m	dB	Detector
1	*	4924.000	29.27	13.89	43.16	54.00	-10.84	AVG
2		4924.880	37.28	13.90	51.18	74.00	-22.82	peak
<b>Remark:</b>								
1. Corr. = Antenna Factor (dB/m) + Cable Loss (dB)								
2. Peak/AVG (dBμV/m) = Corr. (dB/m) + Read Level (dBμV)								
3. Margin (dB) = Peak/AVG (dBμV/m) - Limit PK/AVG (dBμV/m)								
4. The tests evaluated 1-26.5GHz, The testing has been conformed to the 10th harmonic of the highest fundamental frequency.								
5. No report for the emission which more than 20dB below the prescribed limit.								

<b>Temperature:</b>	24.1°C	<b>Relative Humidity:</b>	41%					
<b>Test Voltage:</b>	DC 5V							
<b>Ant. Pol.</b>	Vertical							
<b>Test Mode:</b>	TX G Mode 2462MHz Antenna A							
No.	Mk.	Freq.	Reading Level	Correct Factor	Measurement	Limit	Over	
		MHz	dBuV	dB	dBuV/m	dBuV/m	dB	Detector
1	*	4924.060	27.34	13.89	41.23	54.00	-12.77	AVG
2		4924.100	38.64	13.89	52.53	74.00	-21.47	peak
<b>Remark:</b>								
1. Corr. = Antenna Factor (dB/m) + Cable Loss (dB)								
2. Peak/AVG (dBμV/m) = Corr. (dB/m) + Read Level (dBμV)								
3. Margin (dB) = Peak/AVG (dBμV/m) - Limit PK/AVG (dBμV/m)								
4. The tests evaluated 1-26.5GHz, The testing has been conformed to the 10th harmonic of the highest fundamental frequency.								
5. No report for the emission which more than 20dB below the prescribed limit.								

<b>Temperature:</b>	24.1°C	<b>Relative Humidity:</b>	41%
<b>Test Voltage:</b>	DC 5V		
<b>Ant. Pol.</b>	Horizontal		
<b>Test Mode:</b>	TX n(HT20) Mode 2412MHz Antenna A+B		

No.	Mk.	Freq.	Reading Level	Correct Factor	Measurement	Limit	Over	Detector
		MHz	dBuV	dB	dBuV/m	dBuV/m	dB	
1	*	4824.120	29.49	13.16	42.65	54.00	-11.35	AVG
2		4824.420	38.42	13.16	51.58	74.00	-22.42	peak

**Remark:**

1. Corr. = Antenna Factor (dB/m) + Cable Loss (dB)
2. Peak/AVG (dBμV/m)= Corr. (dB/m)+ Read Level (dBμV)
3. Margin (dB) = Peak/AVG (dBμV/m)-Limit PK/AVG(dBμV/m)
4. The tests evaluated1-26.5GHz,The testing has been conformed to the 10th harmonic of the highest fundamental frequency.
5. No report for the emission which more than 20dB below the prescribed limit.

<b>Temperature:</b>	24.1°C	<b>Relative Humidity:</b>	41%
<b>Test Voltage:</b>	DC 5V		
<b>Ant. Pol.</b>	Vertical		
<b>Test Mode:</b>	TX n(HT20) Mode 2412MHz Antenna A+B		

No.	Mk.	Freq.	Reading Level	Correct Factor	Measurement	Limit	Over	Detector
		MHz	dBuV	dB	dBuV/m	dBuV/m	dB	
1	*	4824.800	28.96	13.16	42.12	54.00	-11.88	AVG
2		4824.880	39.92	13.16	53.08	74.00	-20.92	peak

**Remark:**

1. Corr. = Antenna Factor (dB/m) + Cable Loss (dB)
2. Peak/AVG (dBμV/m)= Corr. (dB/m)+ Read Level (dBμV)
3. Margin (dB) = Peak/AVG (dBμV/m)-Limit PK/AVG(dBμV/m)
4. The tests evaluated1-26.5GHz,The testing has been conformed to the 10th harmonic of the highest fundamental frequency.
5. No report for the emission which more than 20dB below the prescribed limit.

<b>Temperature:</b>	24.1°C	<b>Relative Humidity:</b>	41%					
<b>Test Voltage:</b>	DC 5V							
<b>Ant. Pol.</b>	Horizontal							
<b>Test Mode:</b>	TX n(HT20) Mode 2437MHz Antenna A+B							
No.	Mk.	Freq.	Reading Level	Correct Factor	Measurement	Limit	Over	Detector
		MHz	dBuV	dB	dBuV/m	dBuV/m	dB	
1	*	4874.400	29.08	13.53	42.61	54.00	-11.39	AVG
2		4874.700	38.63	13.53	52.16	74.00	-21.84	peak
<b>Remark:</b>								
1. Corr. = Antenna Factor (dB/m) + Cable Loss (dB)								
2. Peak/AVG (dBμV/m)= Corr. (dB/m)+ Read Level (dBμV)								
3. Margin (dB) = Peak/AVG (dBμV/m)-Limit PK/AVG(dBμV/m)								
4. The tests evaluated1-26.5GHz,The testing has been conformed to the 10th harmonic of the highest fundamental frequency.								
5. No report for the emission which more than 20dB below the prescribed limit.								

<b>Temperature:</b>	24.1°C	<b>Relative Humidity:</b>	41%					
<b>Test Voltage:</b>	DC 5V							
<b>Ant. Pol.</b>	Vertical							
<b>Test Mode:</b>	TX n(HT20) Mode 2437MHz Antenna A+B							
No.	Mk.	Freq.	Reading Level	Correct Factor	Measurement	Limit	Over	Detector
		MHz	dBuV	dB	dBuV/m	dBuV/m	dB	
1		4874.180	39.93	13.53	53.46	74.00	-20.54	peak
2	*	4874.830	29.21	13.53	42.74	54.00	-11.26	AVG
<b>Remark:</b>								
1. Corr. = Antenna Factor (dB/m) + Cable Loss (dB)								
2. Peak/AVG (dBμV/m)= Corr. (dB/m)+ Read Level (dBμV)								
3. Margin (dB) = Peak/AVG (dBμV/m)-Limit PK/AVG(dBμV/m)								
4. The tests evaluated1-26.5GHz,The testing has been conformed to the 10th harmonic of the highest fundamental frequency.								
5. No report for the emission which more than 20dB below the prescribed limit.								

<b>Temperature:</b>	24.1°C	<b>Relative Humidity:</b>	41%				
<b>Test Voltage:</b>	DC 5V						
<b>Ant. Pol.</b>	Horizontal						
<b>Test Mode:</b>	TX n(HT20) Mode 2462MHz Antenna A+B						
No. Mk.	Freq.	Reading Level	Correct Factor	Measurement	Limit	Over	Detector
	MHz	dBuV	dB	dBuV/m	dBuV/m	dB	
1 *	4924.460	28.64	13.89	42.53	54.00	-11.47	AVG
2	4924.600	38.99	13.89	52.88	74.00	-21.12	peak
<b>Remark:</b>							
1. Corr. = Antenna Factor (dB/m) + Cable Loss (dB)							
2. Peak/AVG (dBμV/m)= Corr. (dB/m)+ Read Level (dBμV)							
3. Margin (dB) = Peak/AVG (dBμV/m)-Limit PK/AVG(dBμV/m)							
4. The tests evaluated1-26.5GHz,The testing has been conformed to the 10th harmonic of the highest fundamental frequency.							
5. No report for the emission which more than 20dB below the prescribed limit.							

<b>Temperature:</b>	24.1°C	<b>Relative Humidity:</b>	41%				
<b>Test Voltage:</b>	DC 5V						
<b>Ant. Pol.</b>	Vertical						
<b>Test Mode:</b>	TX n(HT20) Mode 2462MHz Antenna A+B						
No. Mk.	Freq.	Reading Level	Correct Factor	Measurement	Limit	Over	Detector
	MHz	dBuV	dB	dBuV/m	dBuV/m	dB	
1 *	4924.040	28.87	13.89	42.76	54.00	-11.24	AVG
2	4924.630	39.23	13.89	53.12	74.00	-20.88	peak
<b>Remark:</b>							
1. Corr. = Antenna Factor (dB/m) + Cable Loss (dB)							
2. Peak/AVG (dBμV/m)= Corr. (dB/m)+ Read Level (dBμV)							
3. Margin (dB) = Peak/AVG (dBμV/m)-Limit PK/AVG(dBμV/m)							
4. The tests evaluated1-26.5GHz,The testing has been conformed to the 10th harmonic of the highest fundamental frequency.							
5. No report for the emission which more than 20dB below the prescribed limit.							

<b>Temperature:</b>	24.1°C	<b>Relative Humidity:</b>	41%
<b>Test Voltage:</b>	DC 5V		
<b>Ant. Pol.</b>	Horizontal		
<b>Test Mode:</b>	TX n(HT40) Mode 2422MHz Antenna A+B		

No.	Mk.	Freq.	Reading Level	Correct Factor	Measurement	Limit	Over	Detector
		MHz	dBuV	dB	dBuV/m	dBuV/m	dB	
1	*	4844.000	28.76	13.31	42.07	54.00	-11.93	AVG
2		4844.050	39.06	13.31	52.37	74.00	-21.63	peak

**Remark:**

1. Corr. = Antenna Factor (dB/m) + Cable Loss (dB)
2. Peak/AVG (dBμV/m)= Corr. (dB/m)+ Read Level (dBμV)
3. Margin (dB) = Peak/AVG (dBμV/m)-Limit PK/AVG(dBμV/m)
4. The tests evaluated1-26.5GHz,The testing has been conformed to the 10th harmonic of the highest fundamental frequency.
5. No report for the emission which more than 20dB below the prescribed limit.

<b>Temperature:</b>	24.1°C	<b>Relative Humidity:</b>	41%
<b>Test Voltage:</b>	DC 5V		
<b>Ant. Pol.</b>	Vertical		
<b>Test Mode:</b>	TX n(HT40) Mode 2422MHz Antenna A+B		

No.	Mk.	Freq.	Reading Level	Correct Factor	Measurement	Limit	Over	Detector
		MHz	dBuV	dB	dBuV/m	dBuV/m	dB	
1	*	4844.420	29.00	13.31	42.31	54.00	-11.69	AVG
2		4844.540	39.82	13.31	53.13	74.00	-20.87	peak

**Remark:**

1. Corr. = Antenna Factor (dB/m) + Cable Loss (dB)
2. Peak/AVG (dBμV/m)= Corr. (dB/m)+ Read Level (dBμV)
3. Margin (dB) = Peak/AVG (dBμV/m)-Limit PK/AVG(dBμV/m)
4. The tests evaluated1-26.5GHz,The testing has been conformed to the 10th harmonic of the highest fundamental frequency.
5. No report for the emission which more than 20dB below the prescribed limit.

<b>Temperature:</b>	24.1°C	<b>Relative Humidity:</b>	41%
<b>Test Voltage:</b>	DC 5V		
<b>Ant. Pol.</b>	Horizontal		
<b>Test Mode:</b>	TX n(HT40) Mode 2437MHz Antenna A+B		

No.	Mk.	Freq.	Reading Level	Correct Factor	Measurement	Limit	Over	Detector
		MHz	dBuV	dB	dBuV/m	dBuV/m	dB	
1	*	4874.010	29.32	13.53	42.85	54.00	-11.15	AVG
2		4874.900	38.47	13.53	52.00	74.00	-22.00	peak

**Remark:**

1. Corr. = Antenna Factor (dB/m) + Cable Loss (dB)
2. Peak/AVG (dBμV/m)= Corr. (dB/m)+ Read Level (dBμV)
3. Margin (dB) = Peak/AVG (dBμV/m)-Limit PK/AVG(dBμV/m)
4. The tests evaluated 1-26.5GHz, The testing has been conformed to the 10th harmonic of the highest fundamental frequency.
5. No report for the emission which more than 20dB below the prescribed limit.

<b>Temperature:</b>	24.1°C	<b>Relative Humidity:</b>	41%
<b>Test Voltage:</b>	DC 5V		
<b>Ant. Pol.</b>	Vertical		
<b>Test Mode:</b>	TX n(HT40) Mode 2437MHz Antenna A+B		

No.	Mk.	Freq.	Reading Level	Correct Factor	Measurement	Limit	Over	Detector
		MHz	dBuV	dB	dBuV/m	dBuV/m	dB	
1		4873.880	38.65	13.53	52.18	74.00	-21.82	peak
2	*	4874.020	28.25	13.53	41.78	54.00	-12.22	AVG

**Remark:**

1. Corr. = Antenna Factor (dB/m) + Cable Loss (dB)
2. Peak/AVG (dBμV/m)= Corr. (dB/m)+ Read Level (dBμV)
3. Margin (dB) = Peak/AVG (dBμV/m)-Limit PK/AVG(dBμV/m)
4. The tests evaluated 1-26.5GHz, The testing has been conformed to the 10th harmonic of the highest fundamental frequency.
5. No report for the emission which more than 20dB below the prescribed limit.

<b>Temperature:</b>	24.1°C	<b>Relative Humidity:</b>	41%
<b>Test Voltage:</b>	DC 5V		
<b>Ant. Pol.</b>	Horizontal		
<b>Test Mode:</b>	TX n(HT40) Mode 2452MHz Antenna A+B		

No.	Mk.	Freq.	Reading Level	Correct Factor	Measurement	Limit	Over	Detector
		MHz	dBuV	dB	dBuV/m	dBuV/m	dB	
1		4903.980	38.65	13.74	52.39	74.00	-21.61	peak
2	*	4904.000	28.42	13.74	42.16	54.00	-11.84	AVG

**Remark:**

1. Corr. = Antenna Factor (dB/m) + Cable Loss (dB)
2. Peak/AVG (dBμV/m)= Corr. (dB/m)+ Read Level (dBμV)
3. Margin (dB) = Peak/AVG (dBμV/m)-Limit PK/AVG(dBμV/m)
4. The tests evaluated1-26.5GHz,The testing has been conformed to the 10th harmonic of the highest fundamental frequency.
5. No report for the emission which more than 20dB below the prescribed limit.

<b>Temperature:</b>	24.1°C	<b>Relative Humidity:</b>	41%
<b>Test Voltage:</b>	DC 5V		
<b>Ant. Pol.</b>	Vertical		
<b>Test Mode:</b>	TX n(HT40) Mode 2452MHz Antenna A+B		

No.	Mk.	Freq.	Reading Level	Correct Factor	Measurement	Limit	Over	Detector
		MHz	dBuV	dB	dBuV/m	dBuV/m	dB	
1	*	4904.000	28.82	13.74	42.56	54.00	-11.44	AVG
2		4904.500	38.71	13.76	52.47	74.00	-21.53	peak

**Remark:**

1. Corr. = Antenna Factor (dB/m) + Cable Loss (dB)
2. Peak/AVG (dBμV/m)= Corr. (dB/m)+ Read Level (dBμV)
3. Margin (dB) = Peak/AVG (dBμV/m)-Limit PK/AVG(dBμV/m)
4. The tests evaluated1-26.5GHz,The testing has been conformed to the 10th harmonic of the highest fundamental frequency.
5. No report for the emission which more than 20dB below the prescribed limit.

# Attachment C-- Restricted Bands Requirement and Band-edge Test Data

## (1) Radiation Test

Temperature:	24.1 °C	Relative Humidity:	41%
Test Voltage:	DC 5V		
Ant. Pol.	Horizontal		
Test Mode:	TX B Mode 2412MHz		
Remark:	Only show the worst case Antenna A.		

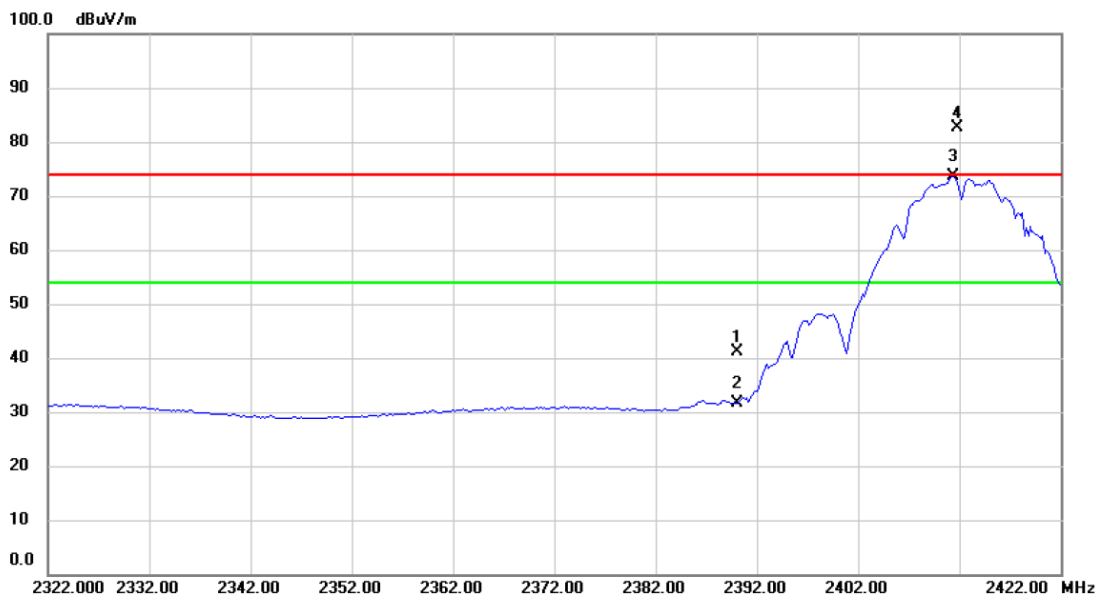

No.	Mk.	Freq. MHz	Reading Level dBuV	Correct Factor dB	Measure- ment dBuV/m	Limit dBuV/m	Over dB	Detector
1		2390.000	39.74	1.28	41.02	74.00	-32.98	peak
2		2390.000	30.37	1.28	31.65	54.00	-22.35	AVG
3	*	2411.400	72.16	1.39	73.55	Fundamental Frequency		AVG
4	X	2411.800	81.17	1.39	82.56	Fundamental Frequency		peak

**Remark:**

1. Corr. = Antenna Factor (dB/m) + Cable Loss (dB)

 2. Peak/AVG (dB $\mu$ V/m) = Corr. (dB/m) + Read Level (dB $\mu$ V)

 3. Margin (dB) = Peak/AVG (dB $\mu$ V/m) - Limit PK/AVG (dB $\mu$ V/m)



Temperature:	24.1°C	Relative Humidity:	41%
Test Voltage:	DC 5V		
Ant. Pol.	Vertical		
Test Mode:	TX B Mode 2412MHz		
Remark:	Only show the worst case Antenna A.		

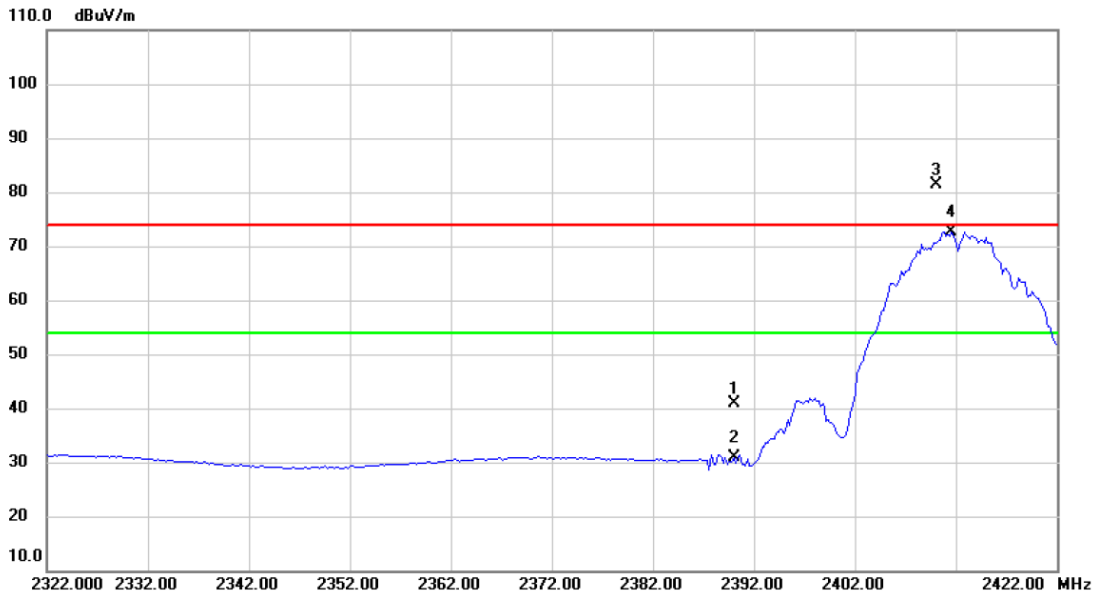

No.	Mk.	Freq. MHz	Reading Level dBuV	Correct Factor dB	Measure- ment dBuV/m	Limit dBuV/m	Over dB	Detector
1		2390.000	39.68	1.28	40.96	74.00	-33.04	peak
2		2390.000	29.68	1.28	30.96	54.00	-23.04	AVG
3	X	2410.000	80.08	1.38	81.46	Fundamental Frequency		peak
4	*	2411.600	71.33	1.39	72.72	Fundamental Frequency		AVG

**Remark:**

1. Corr. = Antenna Factor (dB/m) + Cable Loss (dB)
2. Peak/AVG (dBμV/m)= Corr. (dB/m)+ Read Level (dBμV)
3. Margin (dB) = Peak/AVG (dBμV/m)-Limit PK/AVG(dBμV/m)

<b>Temperature:</b>	24.1°C	<b>Relative Humidity:</b>	41%
<b>Test Voltage:</b>	DC 5V		
<b>Ant. Pol.</b>	Horizontal		
<b>Test Mode:</b>	TX B Mode 2462MHz		
<b>Remark:</b>	Only show the worst case Antenna A.		

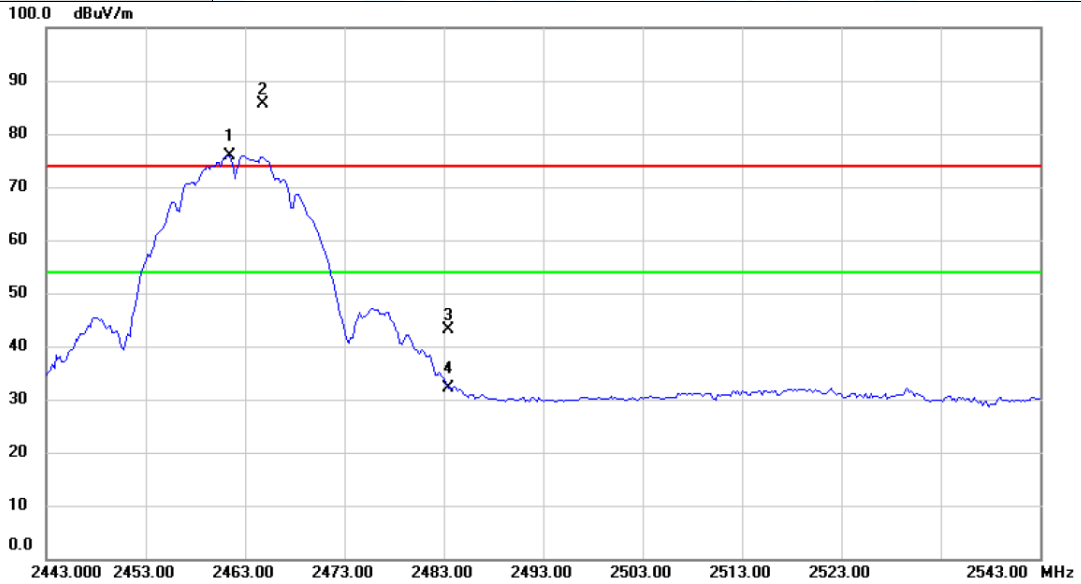

No.	Mk.	Freq. MHz	Reading Level dBuV	Correct Factor dB	Measure- ment dBuV/m	Limit dBuV/m	Over dB	Detector
1	*	2461.400	74.20	1.73	75.93			AVG
2	X	2464.800	83.79	1.75	85.54			peak
3		2483.500	41.24	1.88	43.12	74.00	-30.88	peak
4		2483.500	30.37	1.88	32.25	54.00	-21.75	AVG

**Remark:**

1. Corr. = Antenna Factor (dB/m) + Cable Loss (dB)
2. Peak/AVG (dBμV/m)= Corr. (dB/m)+ Read Level (dBμV)
3. Margin (dB) = Peak/AVG (dBμV/m)-Limit PK/AVG(dBμV/m)

<b>Temperature:</b>	24.1°C	<b>Relative Humidity:</b>	41%
<b>Test Voltage:</b>	DC 5V		
<b>Ant. Pol.</b>	Vertical		
<b>Test Mode:</b>	TX B Mode 2462MHz		
<b>Remark:</b>	Only show the worst case Antenna A.		

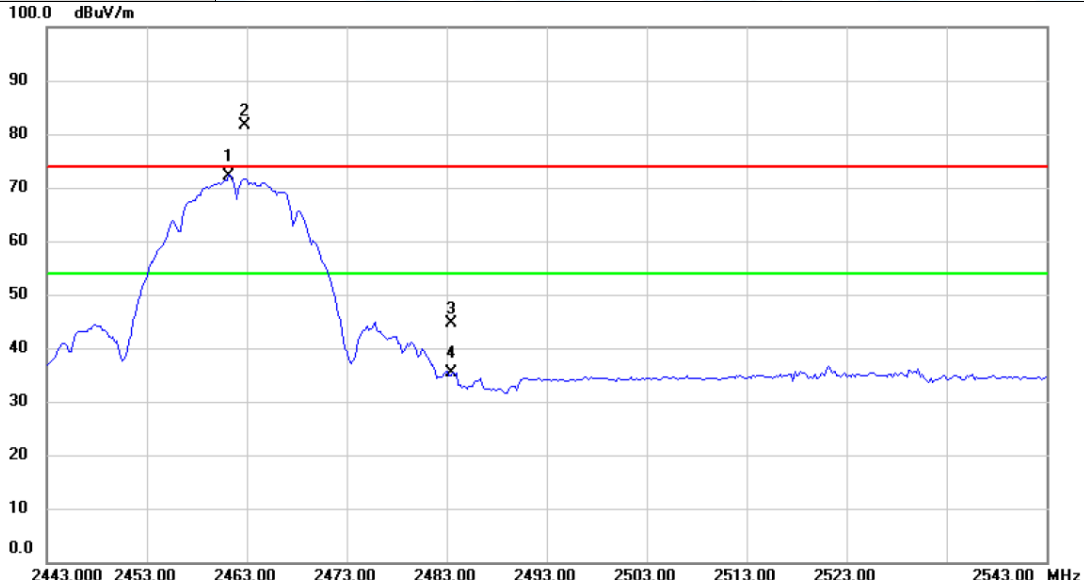

No.	Mk.	Freq. MHz	Reading Level dBuV	Correct Factor dB	Measure- ment dBuV/m	Limit dBuV/m	Over dB	Detector
1	*	2461.200	70.52	1.73	72.25	Fundamental Frequency		AVG
2	X	2462.800	79.82	1.74	81.56	Fundamental Frequency		peak
3		2483.500	42.68	1.88	44.56	74.00	-29.44	peak
4		2483.500	33.40	1.88	35.28	54.00	-18.72	AVG

**Remark:**

1. Corr. = Antenna Factor (dB/m) + Cable Loss (dB)
2. Peak/AVG (dBuV/m) = Corr. (dB/m) + Read Level (dBuV)
3. Margin (dB) = Peak/AVG (dBuV/m) - Limit PK/AVG (dBuV/m)

Temperature:	24.1°C	Relative Humidity:	41%
Test Voltage:	DC 5V		
Ant. Pol.	Horizontal		
Test Mode:	TX G Mode 2412MHz		
Remark:	Only show the worst case Antenna A.		

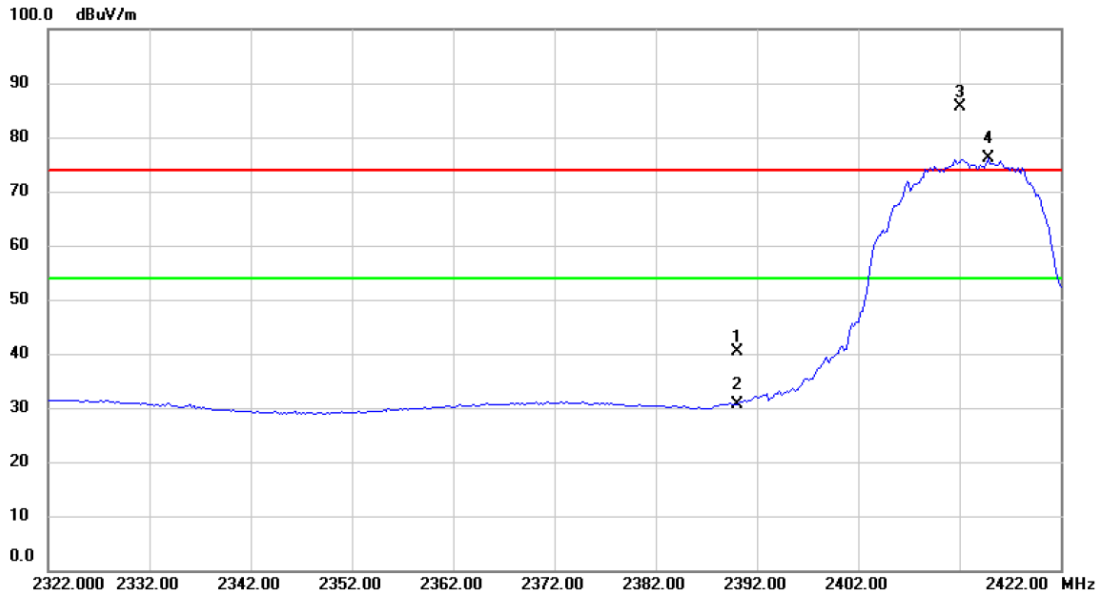

No.	Mk.	Freq. MHz	Reading Level dBuV	Correct Factor dB	Measure- ment dBuV/m	Limit dBuV/m	Over dB	Detector
1		2390.000	39.17	1.28	40.45	74.00	-33.55	peak
2		2390.000	29.42	1.28	30.70	54.00	-23.30	AVG
3	X	2412.133	84.27	1.39	85.66	Fundamental Frequency		peak
4	*	2414.800	74.82	1.41	76.23	Fundamental Frequency		AVG

**Remark:**

1. Corr. = Antenna Factor (dB/m) + Cable Loss (dB)
2. Peak/AVG (dBuV/m) = Corr. (dB/m) + Read Level (dBuV)
3. Margin (dB) = Peak/AVG (dBuV/m) - Limit PK/AVG (dBuV/m)

Temperature:	24.1°C	Relative Humidity:	41%
Test Voltage:	DC 5V		
Ant. Pol.	Vertical		
Test Mode:	TX G Mode 2412MHz		
Remark:	Only show the worst case Antenna A.		

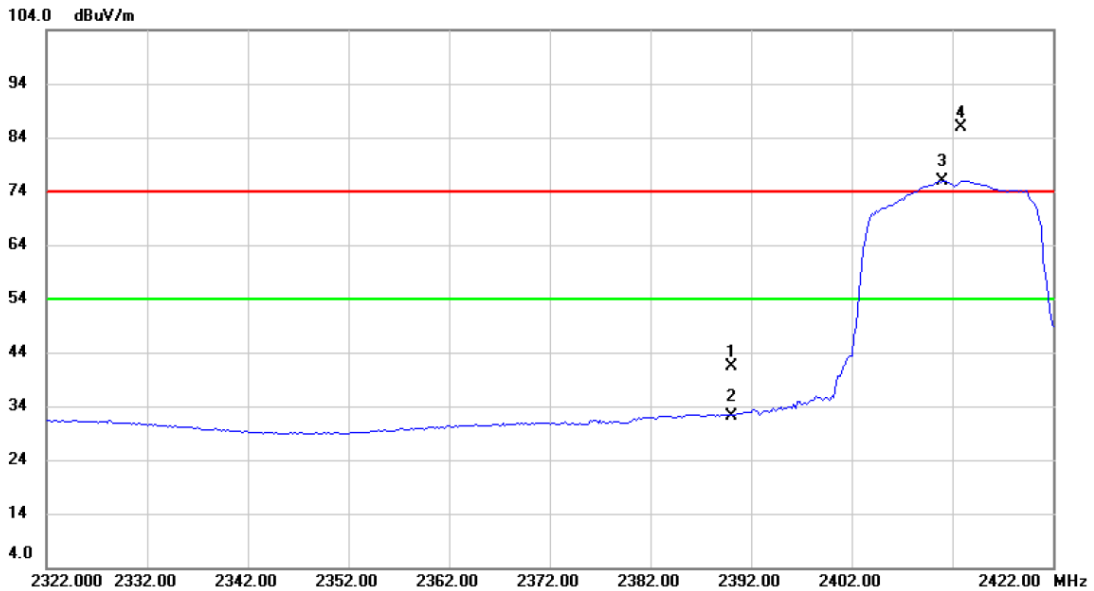

No.	Mk.	Freq. MHz	Reading Level dBuV	Correct Factor dB	Measure- ment dBuV/m	Limit dBuV/m	Over dB	Detector
1		2390.000	39.98	1.28	41.26	74.00	-32.74	peak
2		2390.000	30.97	1.28	32.25	54.00	-21.75	AVG
3	*	2411.000	74.60	1.38	75.98	Fundamental Frequency		AVG
4	X	2412.933	84.46	1.40	85.86	Fundamental Frequency		peak

**Remark:**

1. Corr. = Antenna Factor (dB/m) + Cable Loss (dB)
2. Peak/AVG (dBuV/m) = Corr. (dB/m) + Read Level (dBuV)
3. Margin (dB) = Peak/AVG (dBuV/m) - Limit PK/AVG (dBuV/m)

Temperature:	24.1°C	Relative Humidity:	41%
Test Voltage:	DC 5V		
Ant. Pol.	Horizontal		
Test Mode:	TX G Mode 2462MHz Antenna A+B		
Remark:	Only show the worst case.		

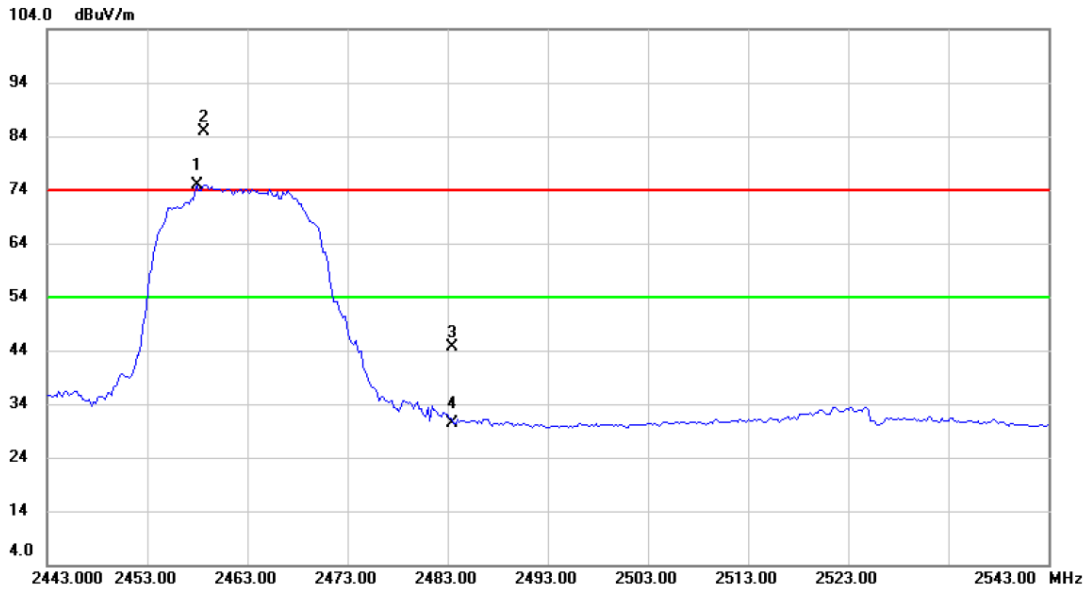

No.	Mk.	Freq. MHz	Reading Level dBuV	Correct Factor dB	Measure- ment dBuV/m	Limit dBuV/m	Over dB	Detector
1	*	2458.000	73.16	1.70	74.86	Fundamental Frequency		AVG
2	X	2458.733	83.10	1.70	84.80	Fundamental Frequency		peak
3		2483.500	42.68	1.88	44.56	74.00	-29.44	peak
4		2483.500	28.39	1.88	30.27	54.00	-23.73	AVG

**Remark:**

1. Corr. = Antenna Factor (dB/m) + Cable Loss (dB)
2. Peak/AVG (dBuV/m)= Corr. (dB/m)+ Read Level (dBuV)
3. Margin (dB) = Peak/AVG (dBuV/m)-Limit PK/AVG(dBuV/m)

<b>Temperature:</b>	24.1°C	<b>Relative Humidity:</b>	41%
<b>Test Voltage:</b>	DC 5V		
<b>Ant. Pol.</b>	Vertical		
<b>Test Mode:</b>	TX G Mode 2462MHz		
<b>Remark:</b>	Only show the worst case Antenna A.		

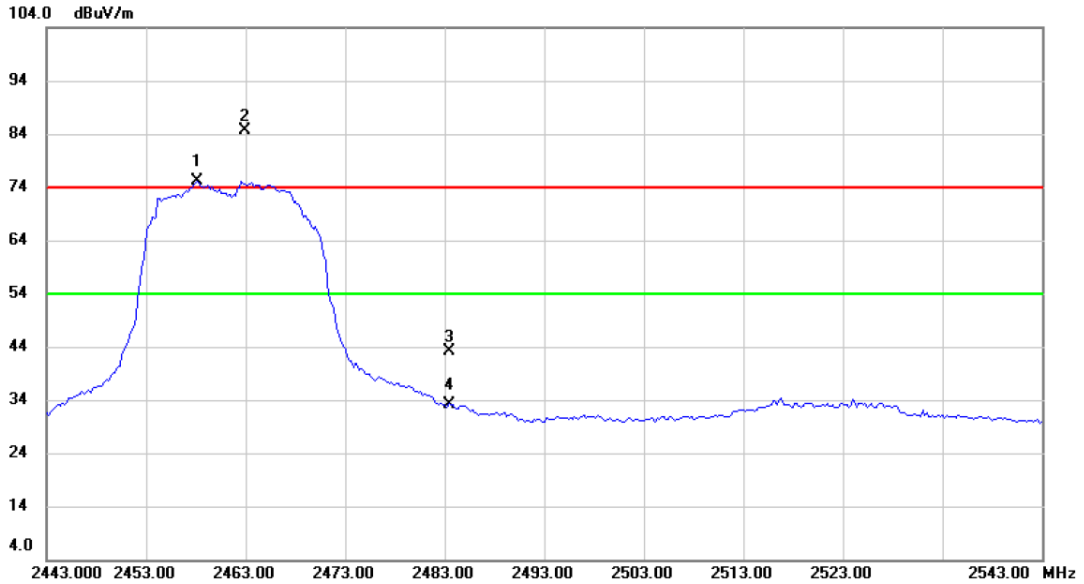

No.	Mk.	Freq. MHz	Reading Level dBuV	Correct Factor dB	Measure- ment dBuV/m	Limit dBuV/m	Over dB	Detector
1	*	2458.200	73.43	1.70	75.13	Fundamental Frequency		AVG
2	X	2462.867	82.86	1.74	84.60	Fundamental Frequency		peak
3		2483.500	41.24	1.88	43.12	74.00	-30.88	peak
4		2483.500	31.15	1.88	33.03	54.00	-20.97	AVG

**Remark:**

1. Corr. = Antenna Factor (dB/m) + Cable Loss (dB)
2. Peak/AVG (dBuV/m)= Corr. (dB/m)+ Read Level (dBuV)
3. Margin (dB) = Peak/AVG (dBuV/m)-Limit PK/AVG(dBuV/m)

<b>Temperature:</b>	24.1°C	<b>Relative Humidity:</b>	41%
<b>Test Voltage:</b>	DC 5V		
<b>Ant. Pol.</b>	Horizontal		
<b>Test Mode:</b>	TX N(HT20) Mode 2412MHz Antenna A+B		
<b>Remark:</b>	Only show the worst case.		

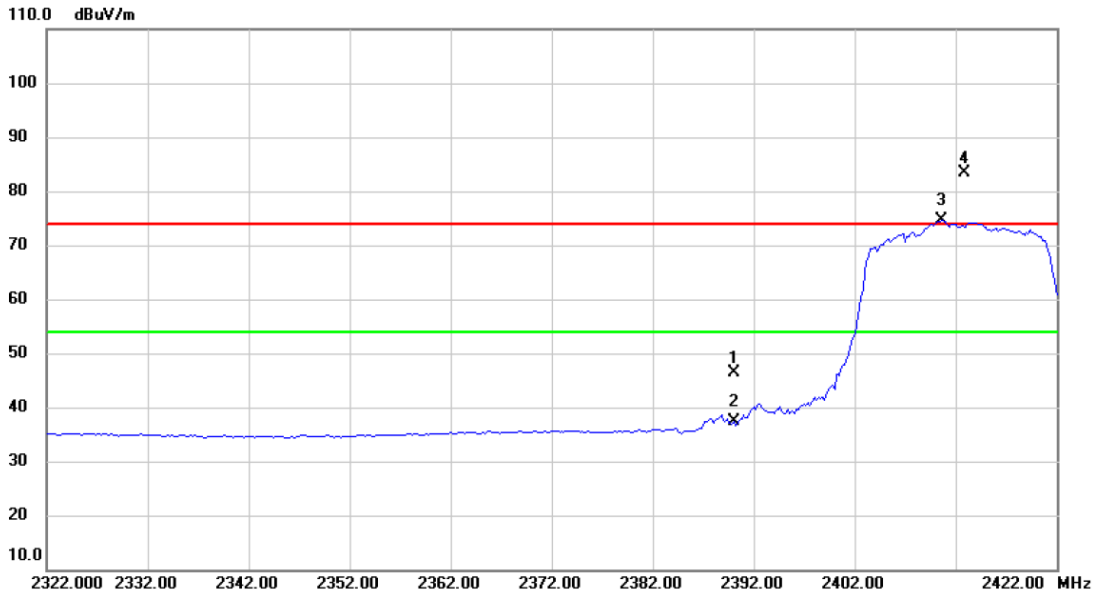

No.	Mk.	Freq. MHz	Reading Level dBuV	Correct Factor dB	Measure- ment dBuV/m	Limit dBuV/m	Over dB	Detector
1		2390.000	45.09	1.28	46.37	74.00	-27.63	peak
2		2390.000	36.13	1.28	37.41	54.00	-16.59	AVG
3	*	2410.600	73.13	1.38	74.51	Fundamental Frequency		AVG
4	X	2412.933	81.93	1.40	83.33	Fundamental Frequency		peak

**Remark:**

1. Corr. = Antenna Factor (dB/m) + Cable Loss (dB)
2. Peak/AVG (dBμV/m)= Corr. (dB/m)+ Read Level (dBμV)
3. Margin (dB) = Peak/AVG (dBμV/m)-Limit PK/AVG(dBμV/m)



Temperature:	24.1°C	Relative Humidity:	41%
Test Voltage:	DC 5V		
Ant. Pol.	Vertical		
Test Mode:	TX N(HT20) Mode 2412MHz Antenna A+B		
Remark:	Only show the worst case.		

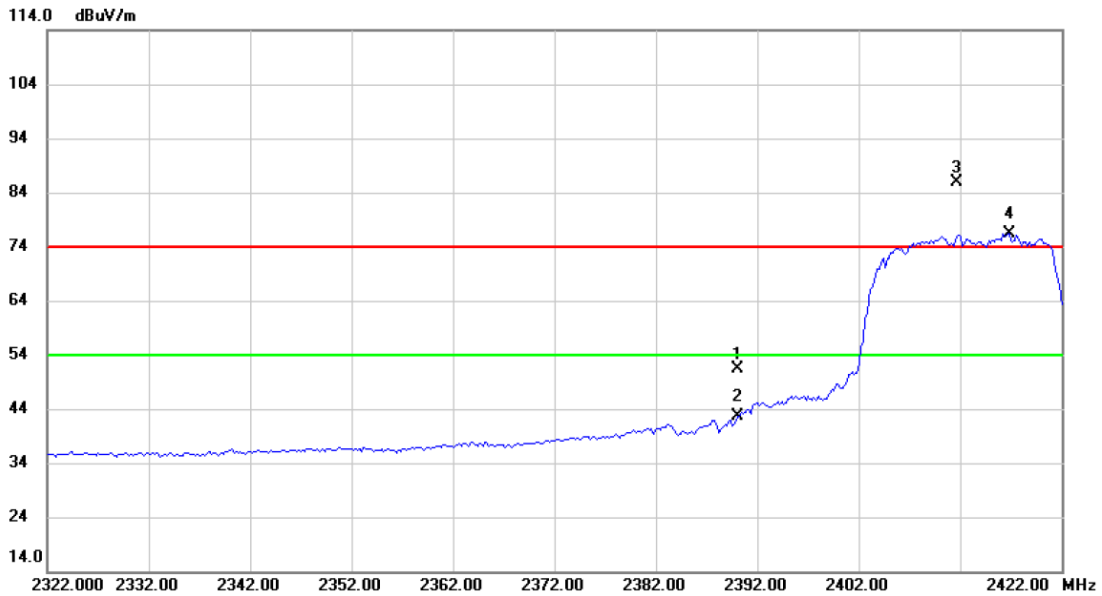

No.	Mk.	Freq. MHz	Reading Level dBuV	Correct Factor dB	Measure- ment dBuV/m	Limit dBuV/m	Over dB	Detector
1		2390.000	49.98	1.28	51.26	74.00	-22.74	peak
2		2390.000	41.29	1.28	42.57	54.00	-11.43	AVG
3	X	2411.733	84.54	1.39	85.93	Fundamental Frequency		peak
4	*	2416.800	74.98	1.43	76.41	Fundamental Frequency		AVG

**Remark:**

1. Corr. = Antenna Factor (dB/m) + Cable Loss (dB)
2. Peak/AVG (dBuV/m) = Corr. (dB/m) + Read Level (dBuV)
3. Margin (dB) = Peak/AVG (dBuV/m) - Limit PK/AVG (dBuV/m)

<b>Temperature:</b>	24.1°C	<b>Relative Humidity:</b>	41%
<b>Test Voltage:</b>	DC 5V		
<b>Ant. Pol.</b>	Horizontal		
<b>Test Mode:</b>	TX N(HT20) Mode 2462MHz Antenna A+B		
<b>Remark:</b>	Only show the worst case.		

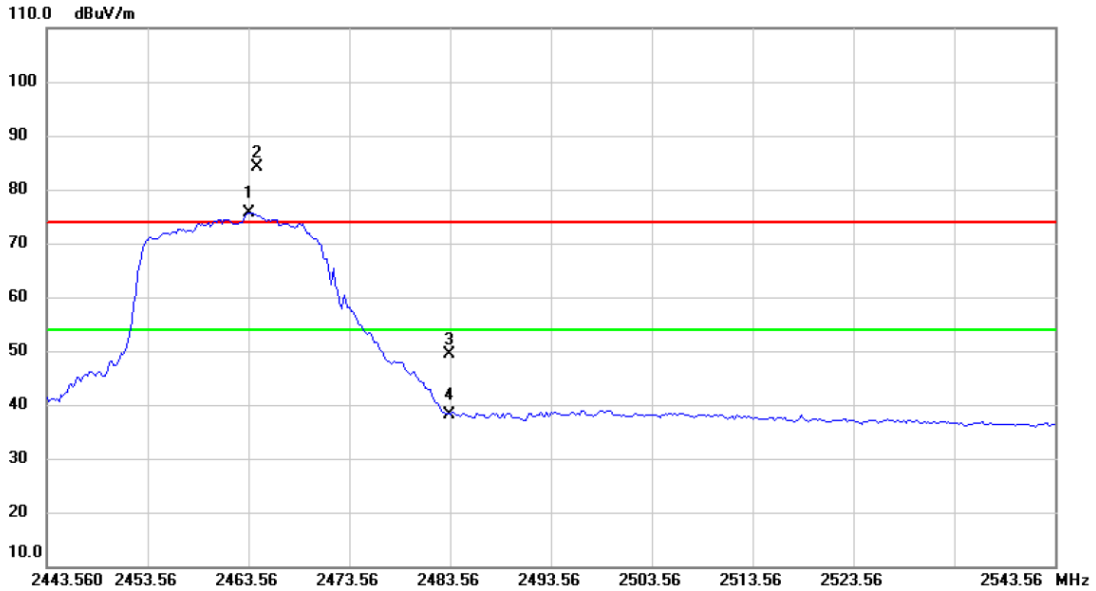

No.	Mk.	Freq. MHz	Reading Level dBuV	Correct Factor dB	Measure- ment dBuV/m	Limit dBuV/m	Over dB	Detector
1	*	2463.560	73.98	1.75	75.73	Fundamental Frequency		AVG
2	X	2464.360	82.47	1.75	84.22	Fundamental Frequency		peak
3		2483.500	47.55	1.88	49.43	74.00	-24.57	peak
4		2483.500	36.24	1.88	38.12	54.00	-15.88	AVG

**Remark:**

1. Corr. = Antenna Factor (dB/m) + Cable Loss (dB)
2. Peak/AVG (dBuV/m)= Corr. (dB/m)+ Read Level (dBuV)
3. Margin (dB) = Peak/AVG (dBuV/m)-Limit PK/AVG(dBuV/m)

Temperature:	24.1°C	Relative Humidity:	41%
Test Voltage:	DC 5V		
Ant. Pol.	Vertical		
Test Mode:	TX N(HT20) Mode 2462MHz Antenna A+B		
Remark:	Only show the worst case.		

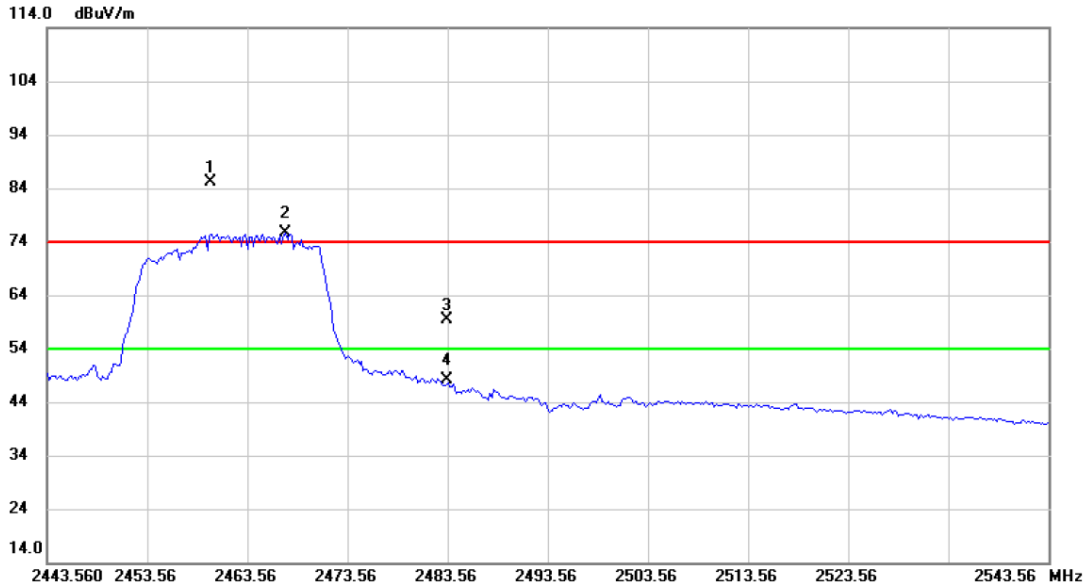

No.	Mk.	Freq. MHz	Reading Level dBuV	Correct Factor dB	Measure- ment dBuV/m	Limit dBuV/m	Over dB	Detector
1	X	2459.827	83.40	1.72	85.12	Fundamental Frequency		peak
2	*	2467.360	73.78	1.78	75.56	Fundamental Frequency		AVG
3		2483.500	57.55	1.88	59.43	74.00	-14.57	peak
4		2483.500	46.24	1.88	48.12	54.00	-5.88	AVG

**Remark:**

1. Corr. = Antenna Factor (dB/m) + Cable Loss (dB)
2. Peak/AVG (dBμV/m)= Corr. (dB/m)+ Read Level (dBμV)
3. Margin (dB) = Peak/AVG (dBμV/m)-Limit PK/AVG(dBμV/m)

<b>Temperature:</b>	24.1°C	<b>Relative Humidity:</b>	41%
<b>Test Voltage:</b>	DC 5V		
<b>Ant. Pol.</b>	Horizontal		
<b>Test Mode:</b>	TX N(HT40) Mode 2422MHz Antenna A+B		
<b>Remark:</b>	Only show the worst case.		

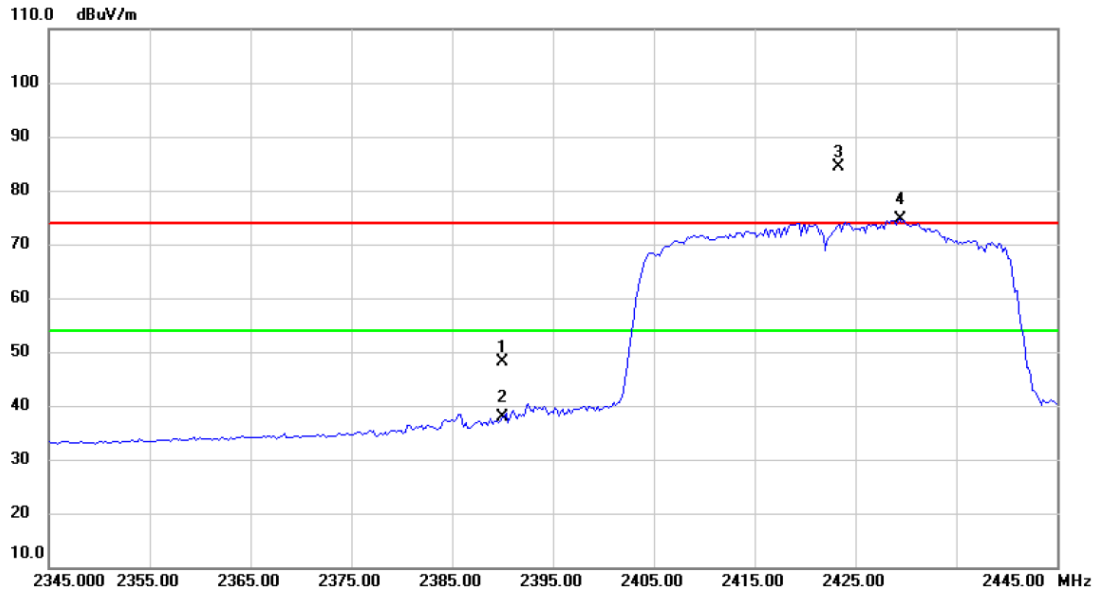

No.	Mk.	Freq. MHz	Reading Level dBuV	Correct Factor dB	Measure- ment dBuV/m	Limit dBuV/m	Over dB	Detector
1		2390.000	46.88	1.28	48.16	74.00	-25.84	peak
2		2390.000	36.66	1.28	37.94	54.00	-16.06	AVG
3	X	2423.267	82.95	1.48	84.43	Fundamental Frequency		peak
4	*	2429.400	73.03	1.51	74.54	Fundamental Frequency		AVG

**Remark:**

1. Corr. = Antenna Factor (dB/m) + Cable Loss (dB)
2. Peak/AVG (dBuV/m) = Corr. (dB/m) + Read Level (dBuV)
3. Margin (dB) = Peak/AVG (dBuV/m) - Limit PK/AVG (dBuV/m)

Temperature:	24.1°C	Relative Humidity:	41%
Test Voltage:	DC 5V		
Ant. Pol.	Vertical		
Test Mode:	TX N(HT40) Mode 2422MHz Antenna A+B		
Remark:	Only show the worst case.		

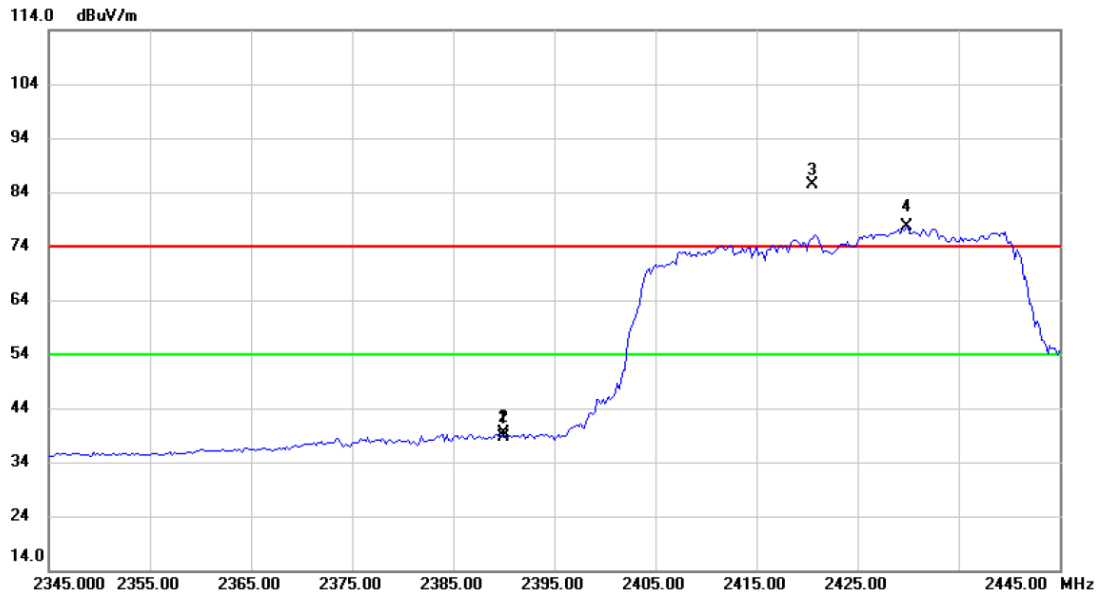

No.	Mk.	Freq. MHz	Reading Level dBuV	Correct Factor dB	Measure- ment dBuV/m	Limit dBuV/m	Over dB	Detector
1		2390.000	38.13	1.28	39.41	74.00	-34.59	peak
2		2390.000	37.32	1.28	38.60	54.00	-15.40	AVG
3	X	2420.600	83.99	1.45	85.44	Fundamental Frequency		peak
4	*	2429.800	76.05	1.51	77.56	Fundamental Frequency		AVG

**Remark:**

1. Corr. = Antenna Factor (dB/m) + Cable Loss (dB)
2. Peak/AVG (dBμV/m)= Corr. (dB/m)+ Read Level (dBμV)
3. Margin (dB) = Peak/AVG (dBμV/m)-Limit PK/AVG(dBμV/m)

<b>Temperature:</b>	24.1°C	<b>Relative Humidity:</b>	41%
<b>Test Voltage:</b>	DC 5V		
<b>Ant. Pol.</b>	Horizontal		
<b>Test Mode:</b>	TX N(HT40) Mode 2452MHz Antenna A+B		
<b>Remark:</b>	Only show the worst case.		

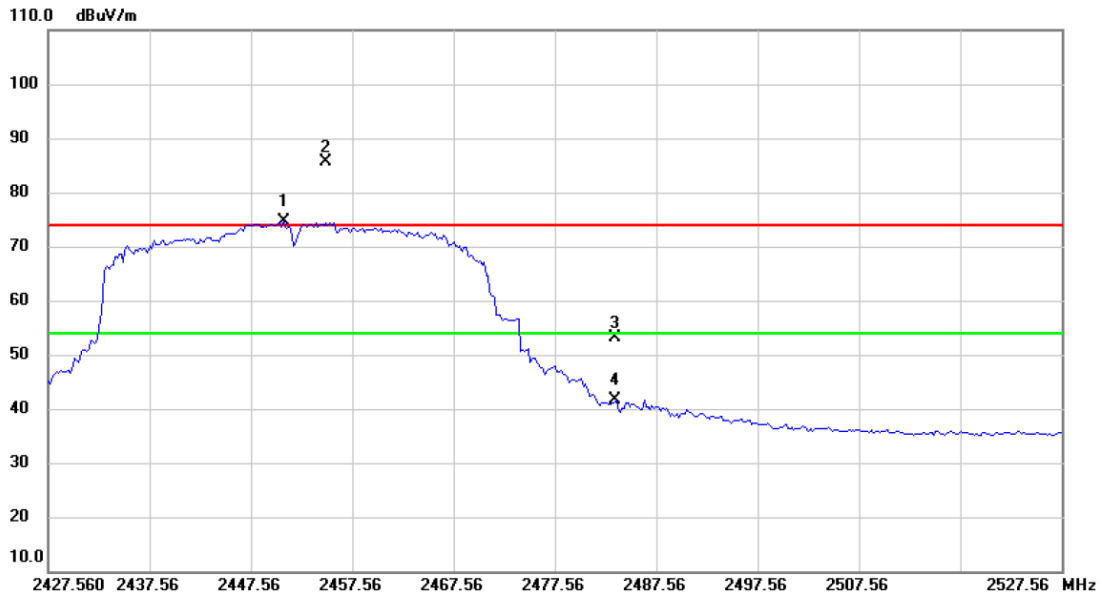

No.	Mk.	Freq. MHz	Reading Level dBuV	Correct Factor dB	Measure- ment dBuV/m	Limit dBuV/m	Over dB	Detector
1	*	2450.760	72.99	1.65	74.64	Fundamental Frequency		AVG
2	X	2454.960	83.83	1.68	85.51	Fundamental Frequency		peak
3		2483.500	51.30	1.88	53.18	74.00	-20.82	peak
4		2483.500	39.66	1.88	41.54	54.00	-12.46	AVG

**Remark:**

1. Corr. = Antenna Factor (dB/m) + Cable Loss (dB)
2. Peak/AVG (dBμV/m)= Corr. (dB/m)+ Read Level (dBμV)
3. Margin (dB) = Peak/AVG (dBμV/m)-Limit PK/AVG(dBμV/m)

Temperature:	24.1°C	Relative Humidity:	41%
Test Voltage:	DC 5V		
Ant. Pol.	Vertical		
Test Mode:	TX N(HT40) Mode 2452MHz Antenna A+B		
Remark:	Only show the worst case.		

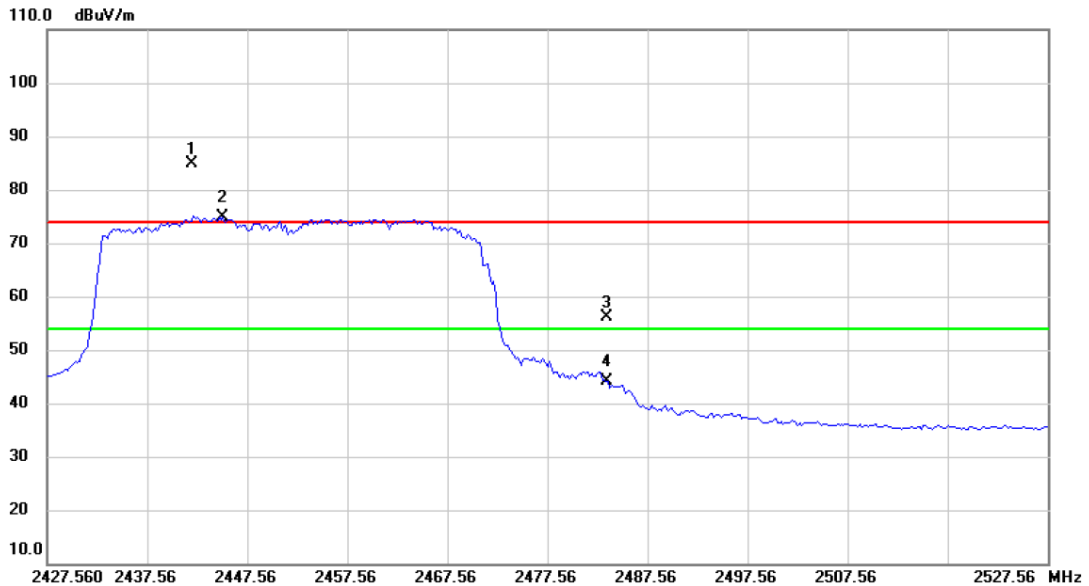

No.	Mk.	Freq. MHz	Reading Level dBuV	Correct Factor dB	Measure- ment dBuV/m	Limit dBuV/m	Over dB	Detector
1	X	2442.093	83.25	1.60	84.85	----- Fundamental Frequency	-----	peak
2	*	2445.160	73.33	1.63	74.96	Fundamental Frequency	-----	AVG
3		2483.500	54.17	1.88	56.05	74.00	-17.95	peak
4		2483.500	42.16	1.88	44.04	54.00	-9.96	AVG

**Remark:**

1. Corr. = Antenna Factor (dB/m) + Cable Loss (dB)
2. Peak/AVG (dBμV/m)= Corr. (dB/m)+ Read Level (dBμV)
3. Margin (dB) = Peak/AVG (dBμV/m)-Limit PK/AVG(dBμV/m)

**(2) Conducted Test**

Test Mode	Antenna	Ch Name	Channel	Ref Leve l[dBm]	Result [dBm]	Limit [dBm]	Verdict
11B	Ant.A	Low	2412	-9.51	-52.53	<=-29.51	PASS
	Ant.B	Low	2412	-9.32	-51.94	<=-29.32	PASS
	Ant.A	High	2462	-10.59	-50.1	<=-30.59	PASS
	Ant.B	High	2462	-9.01	-49.51	<=-29.01	PASS
11G	Ant.A	Low	2412	-17.79	-51.43	<=-37.79	PASS
	Ant.B	Low	2412	-16.86	-50.76	<=-36.86	PASS
	Ant.A	High	2462	-17.14	-50.24	<=-37.14	PASS
	Ant.B	High	2462	-17.21	-51.21	<=-37.21	PASS
11N20MIMO	Ant.A	Low	2412	-18.74	-52.11	<=-38.74	PASS
	Ant.B	Low	2412	-18.57	-51.81	<=-38.57	PASS
	Ant.A	High	2462	-18.68	-50.02	<=-38.68	PASS
	Ant.B	High	2462	-17.88	-50.15	<=-37.88	PASS
11N40MIMO	Ant.A	Low	2422	-21.50	-51.59	<=-41.5	PASS
	Ant.B	Low	2422	-21.25	-51.08	<=-41.25	PASS
	Ant.A	High	2452	-21.37	-50.25	<=-41.37	PASS
	Ant.B	High	2452	-20.98	-50.63	<=-40.98	PASS



Test Graphs

11B\_Ant.A\_Low\_2412



11B\_Ant.B\_Low\_2412

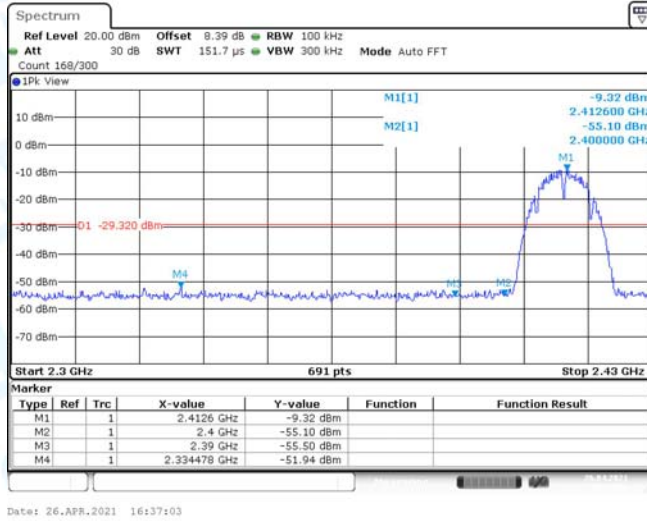

11B\_Ant.A\_High\_2462

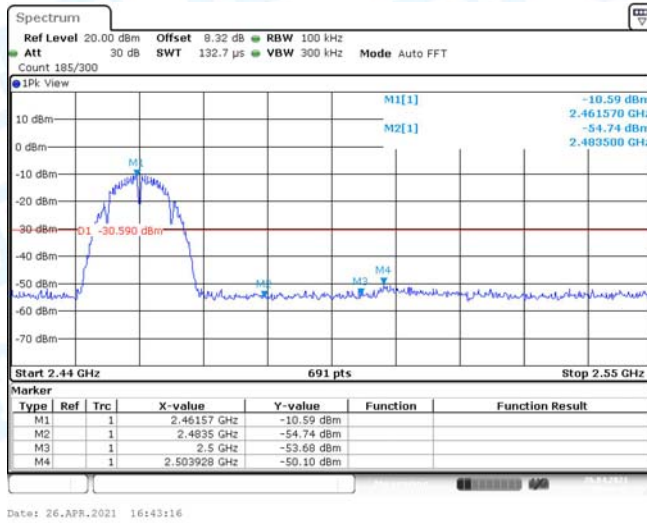

11B\_Ant.B\_High\_2462

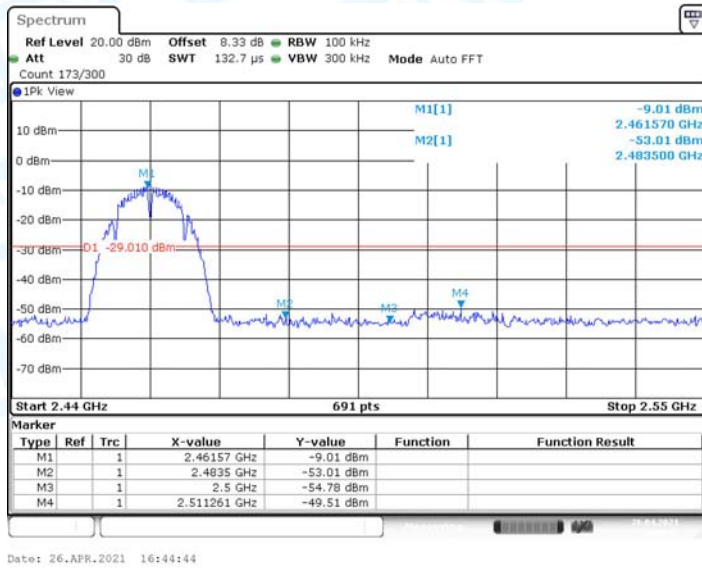

11G\_Ant.A\_Low\_2412

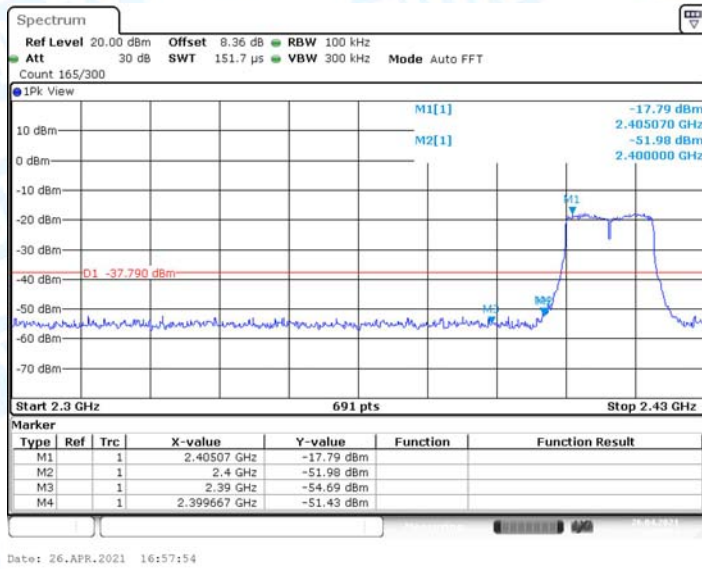

11G\_Ant.B\_Low\_2412

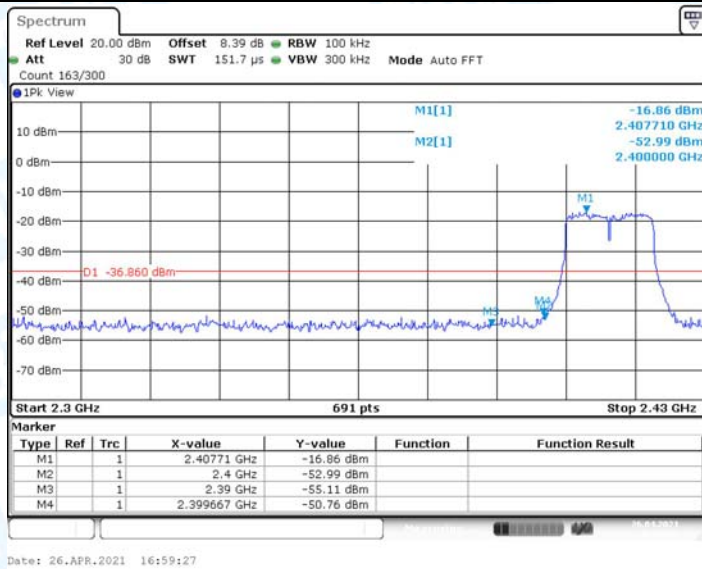

11G\_Ant.A\_High\_2462

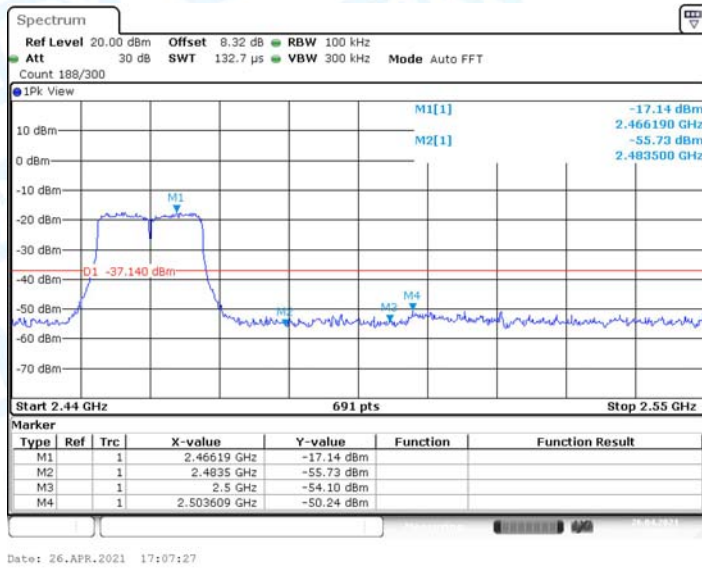

11G\_Ant.B\_High\_2462

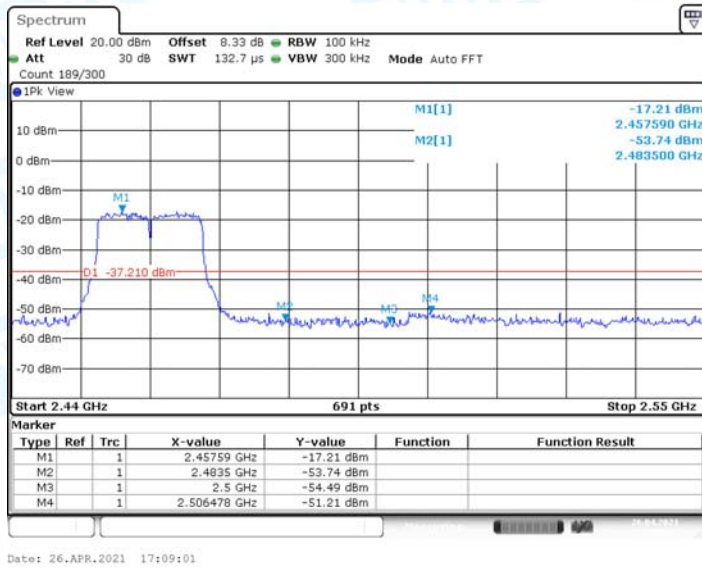

11N20MIMO\_Ant.A\_Low\_2412

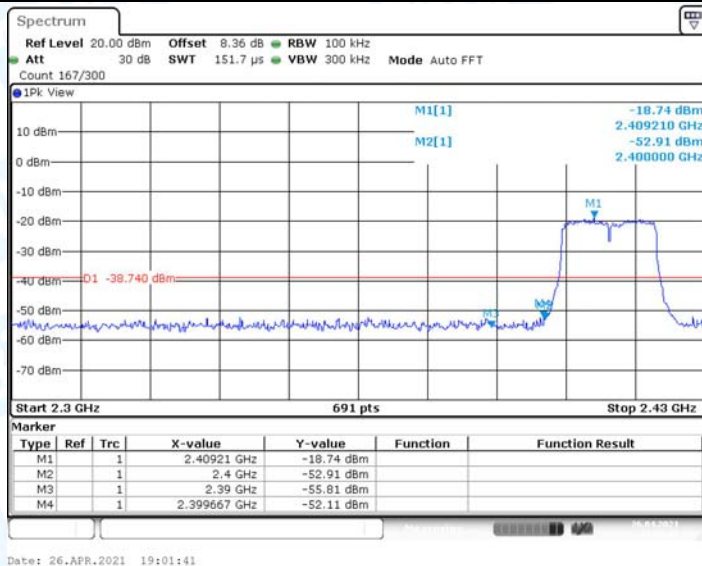

11N20MIMO\_Ant.B\_Low\_2412

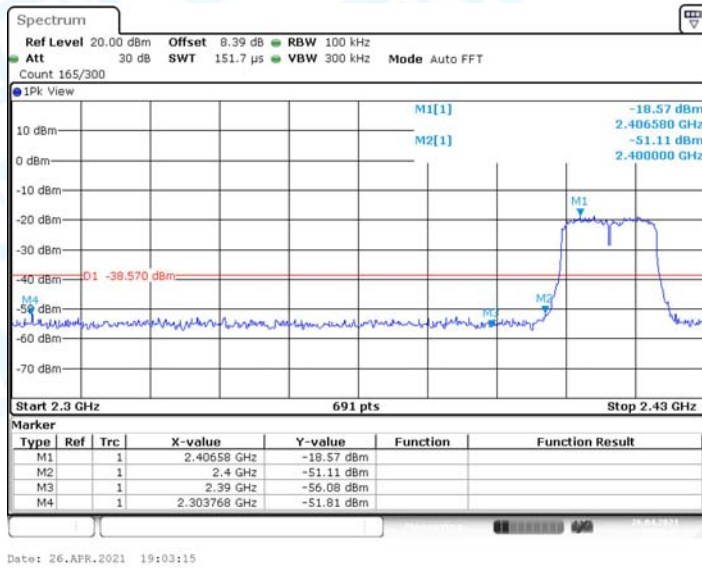

11N20MIMO\_Ant.A\_High\_2462

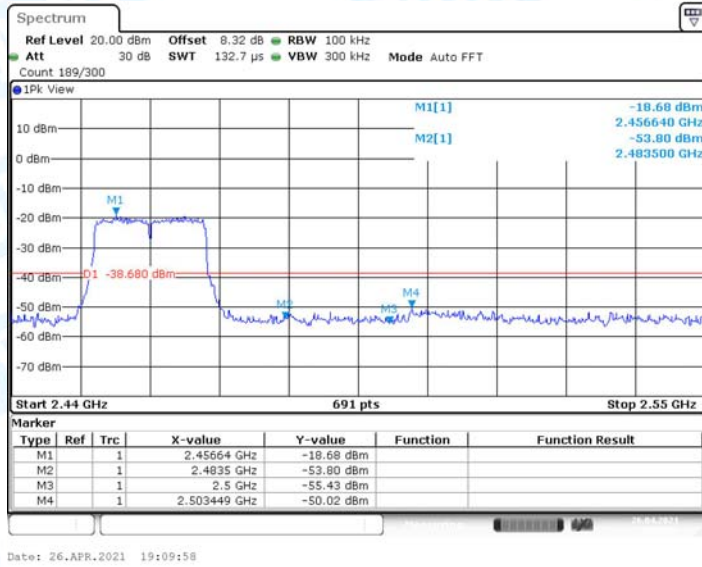

11N20MIMO\_Ant.B\_High\_2462

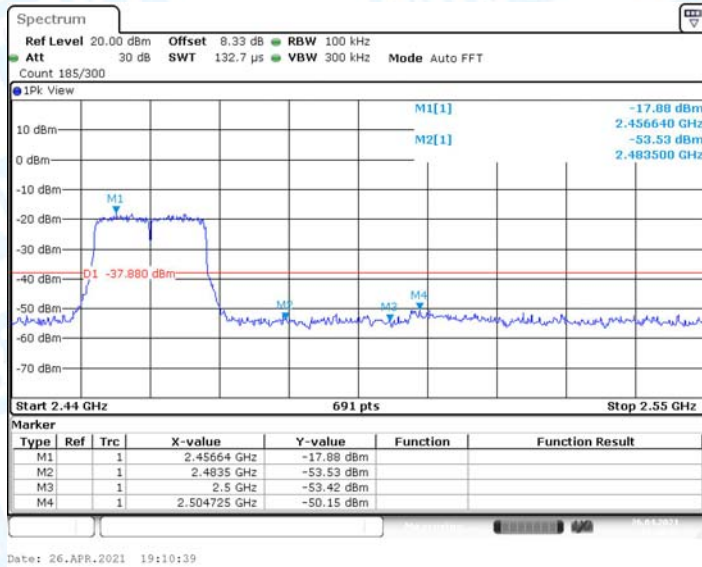

11N40MIMO\_Ant.A\_Low\_2422

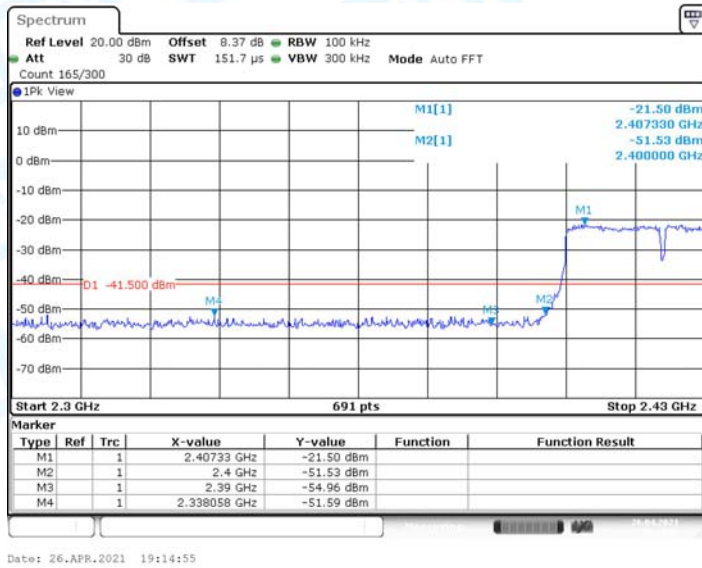

11N40MIMO\_Ant.B\_Low\_2422

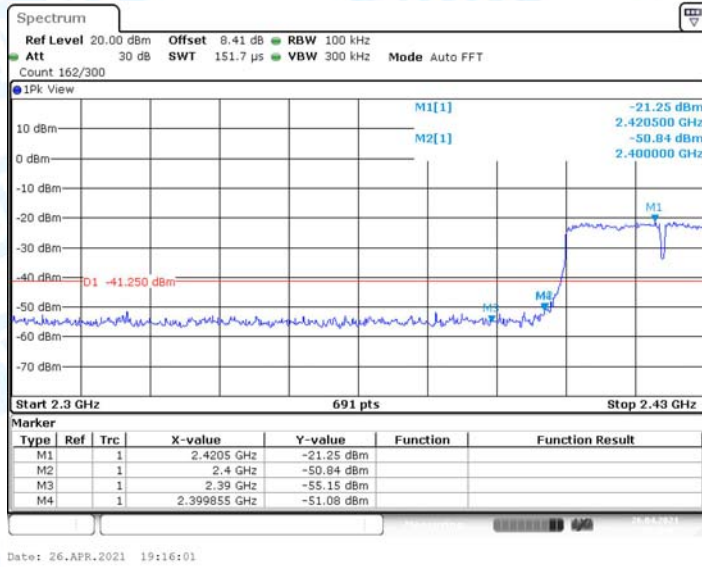

11N40MIMO\_Ant.A\_High\_2452

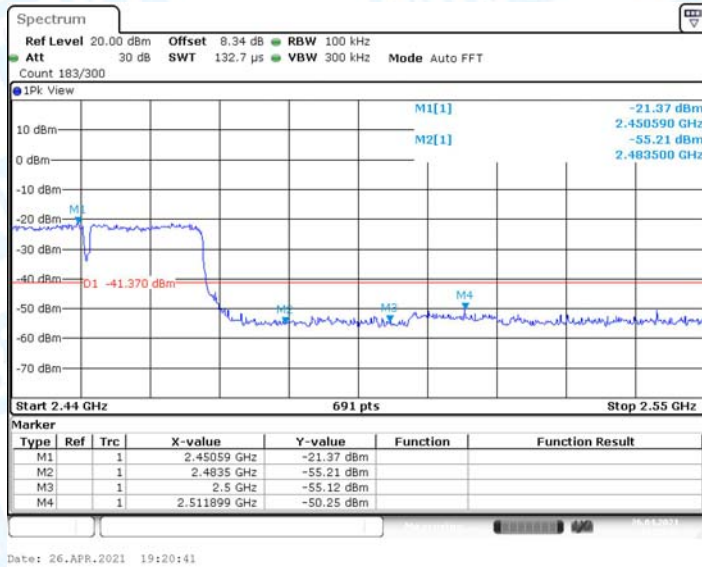

11N40MIMO\_Ant.B\_High\_2452

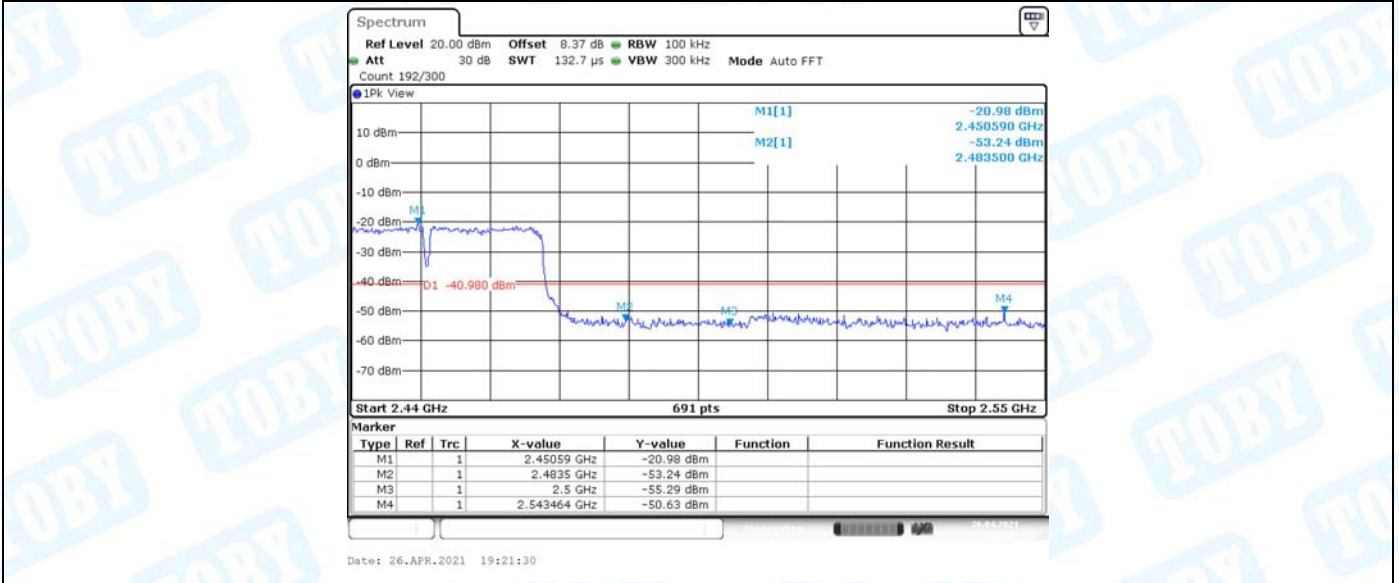

## Attachment D-- Bandwidth Test Data

Test Mode	Antenna	Channel	DTS BW [MHz]	FL[MHz]	FH[MHz]	Limit[MHz]	Verdict
11B	Ant.A	2412	9.200	2407.400	2416.600	0.5	PASS
	Ant.B	2412	9.200	2407.400	2416.600	0.5	PASS
	Ant.A	2437	9.200	2432.400	2441.600	0.5	PASS
	Ant.B	2437	9.200	2432.400	2441.600	0.5	PASS
	Ant.A	2462	9.640	2456.960	2466.600	0.5	PASS
	Ant.B	2462	9.640	2456.960	2466.600	0.5	PASS
11G	Ant.A	2412	16.640	2403.680	2420.320	0.5	PASS
	Ant.B	2412	16.560	2403.760	2420.320	0.5	PASS
	Ant.A	2437	16.560	2428.680	2445.240	0.5	PASS
	Ant.B	2437	16.520	2428.760	2445.280	0.5	PASS
	Ant.A	2462	16.600	2453.680	2470.280	0.5	PASS
	Ant.B	2462	16.560	2453.760	2470.320	0.5	PASS
11N20MIMO	Ant.A	2412	17.680	2403.160	2420.840	0.5	PASS
	Ant.B	2412	17.680	2403.160	2420.840	0.5	PASS
	Ant.A	2437	17.680	2428.160	2445.840	0.5	PASS
	Ant.B	2437	17.680	2428.160	2445.840	0.5	PASS
	Ant.A	2462	17.680	2453.160	2470.840	0.5	PASS
	Ant.B	2462	17.680	2453.160	2470.840	0.5	PASS
11N40MIMO	Ant.A	2422	36.640	2403.680	2440.320	0.5	PASS
	Ant.B	2422	36.640	2403.680	2440.320	0.5	PASS
	Ant.A	2437	36.640	2418.680	2455.320	0.5	PASS
	Ant.B	2437	36.640	2418.680	2455.320	0.5	PASS
	Ant.A	2452	36.640	2433.680	2470.320	0.5	PASS
	Ant.B	2452	36.640	2433.680	2470.320	0.5	PASS

Test Graphs

11B\_Ant.A\_2412

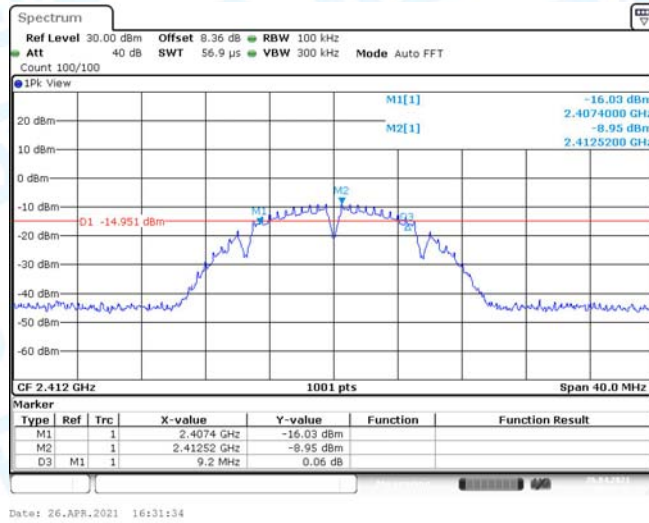

11B\_Ant.B\_2412

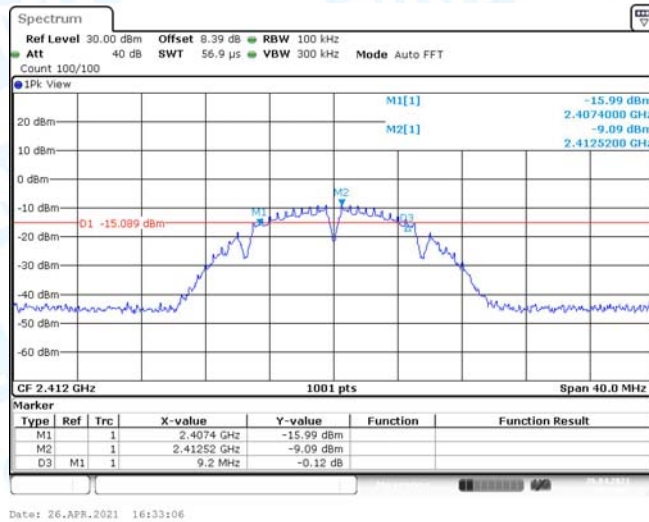

11B\_Ant.A\_2437

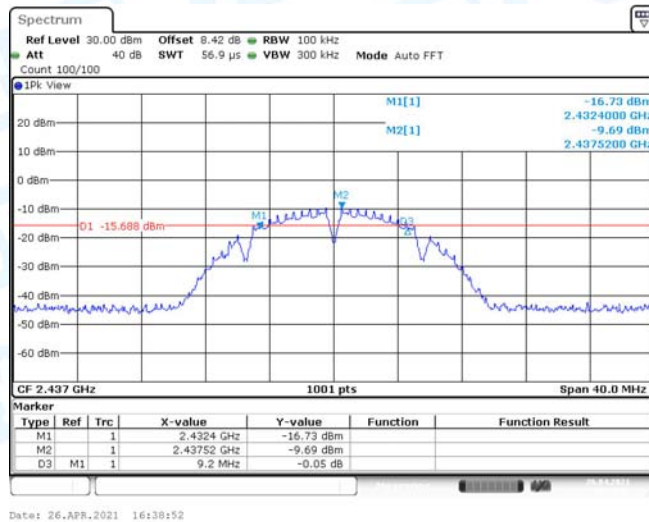



11B\_Ant.B\_2437

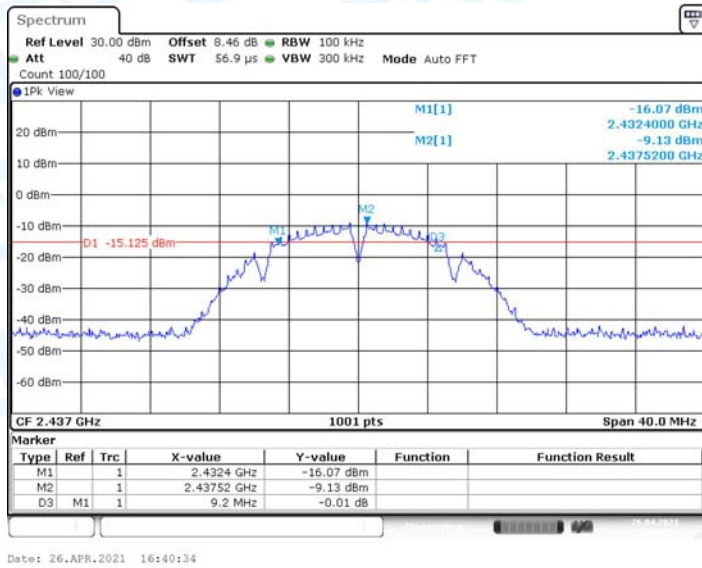

11B\_Ant.A\_2462

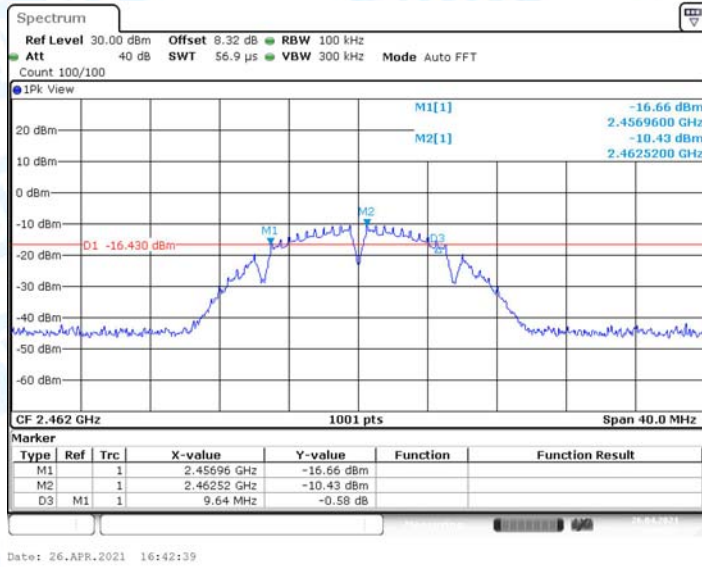

11B\_Ant.B\_2462

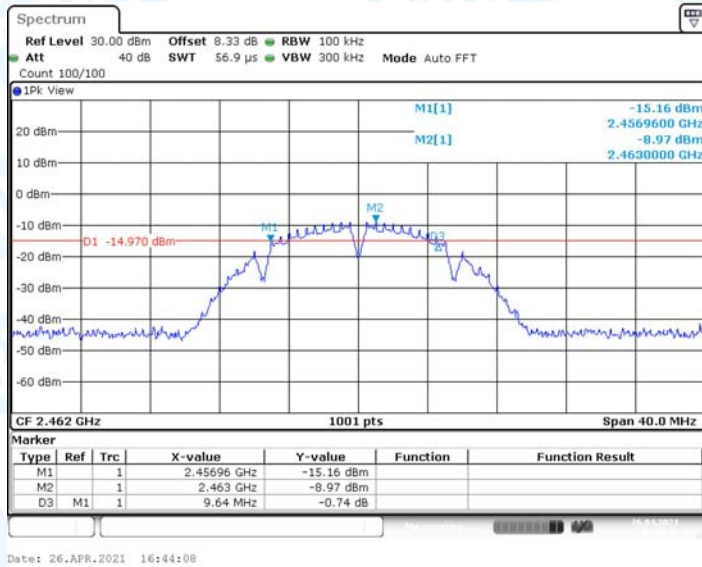

11G\_Ant.A\_2412

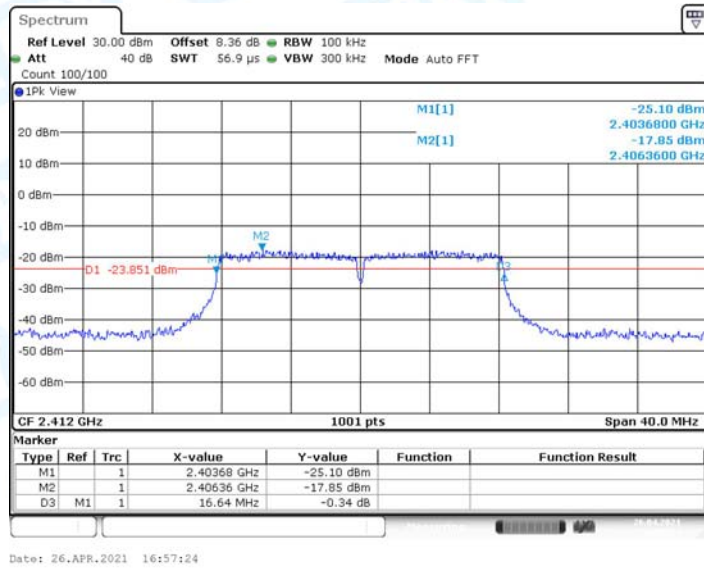

11G\_Ant.B\_2412

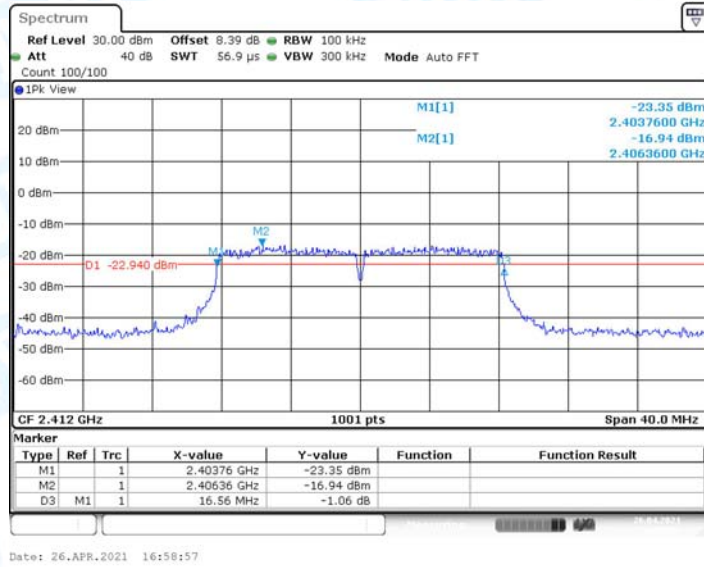

11G\_Ant.A\_2437

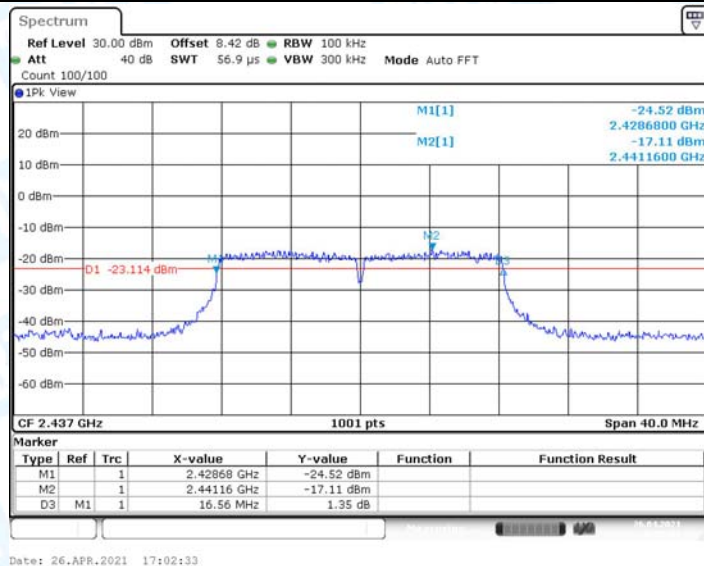

11G\_Ant.B\_2437

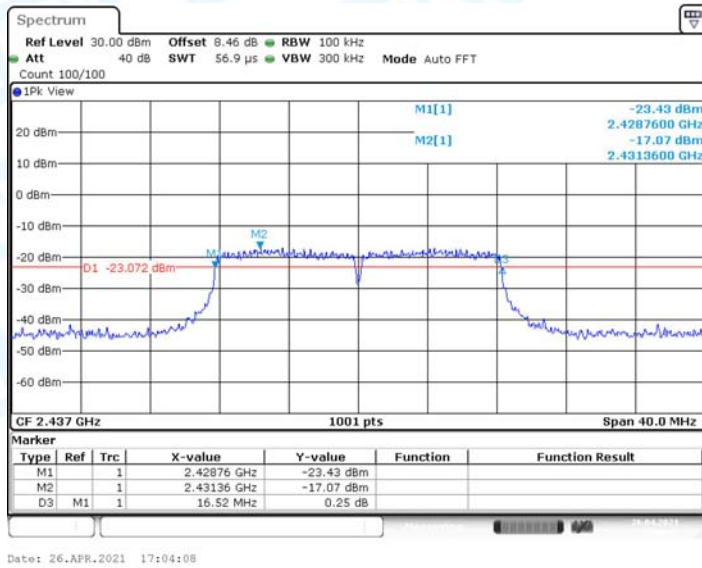

11G\_Ant.A\_2462

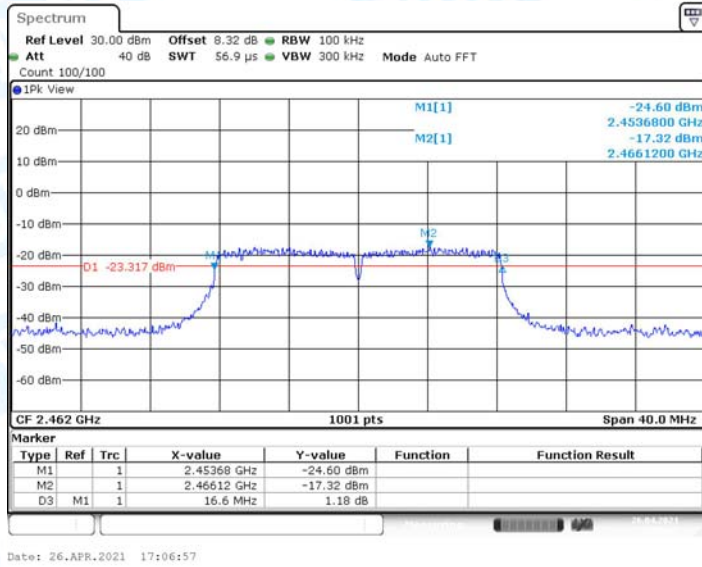

11G\_Ant.B\_2462

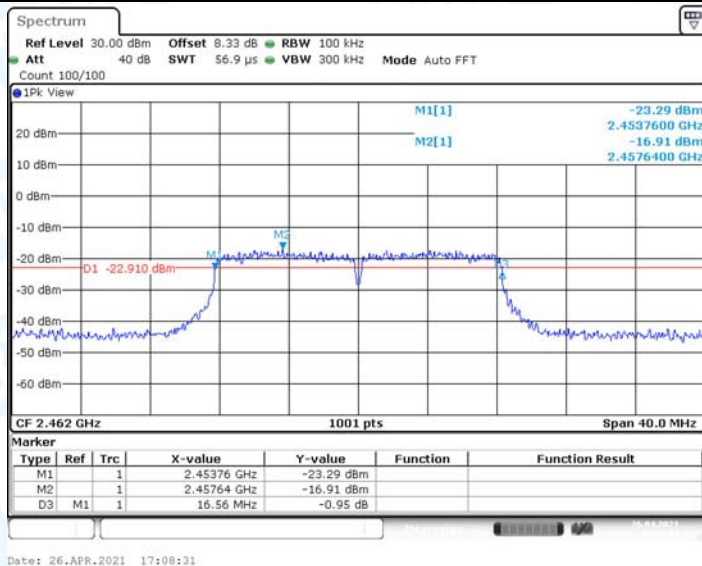

11N20MIMO\_Ant.A\_2412

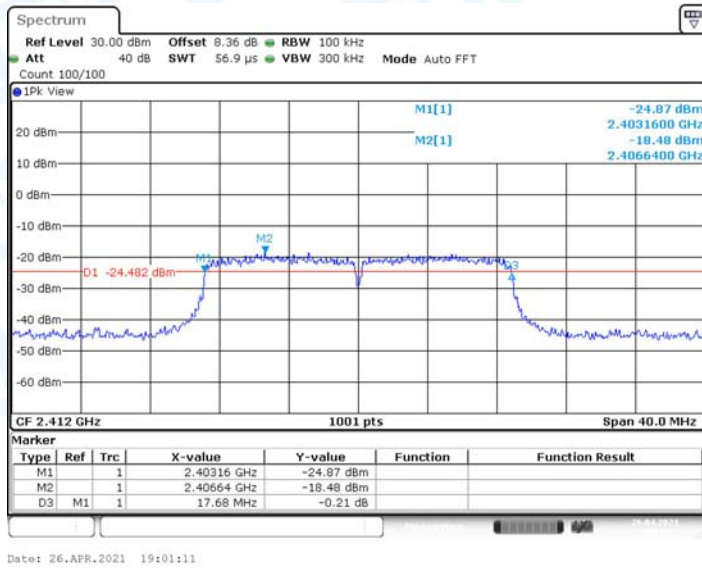

11N20MIMO\_Ant.B\_2412

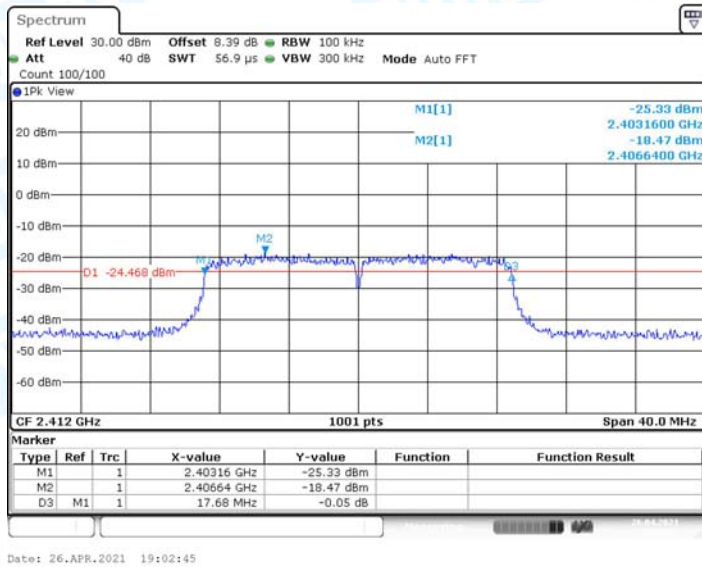

11N20MIMO\_Ant.A\_2437

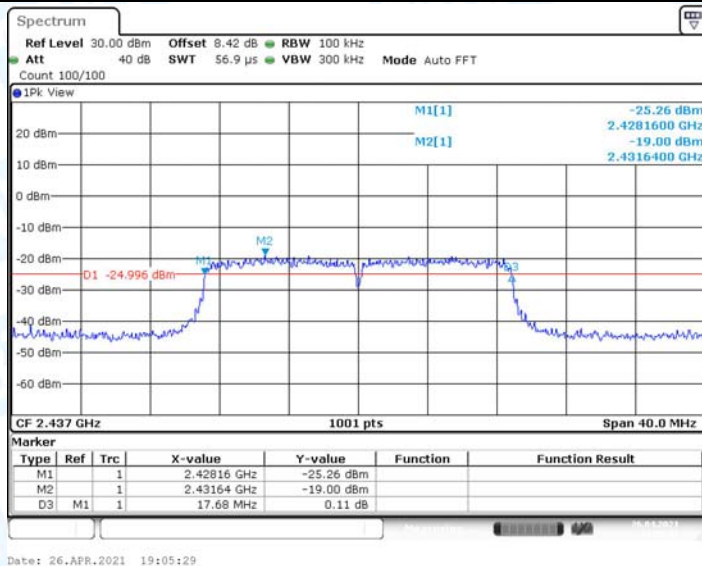

11N20MIMO\_Ant.B\_2437

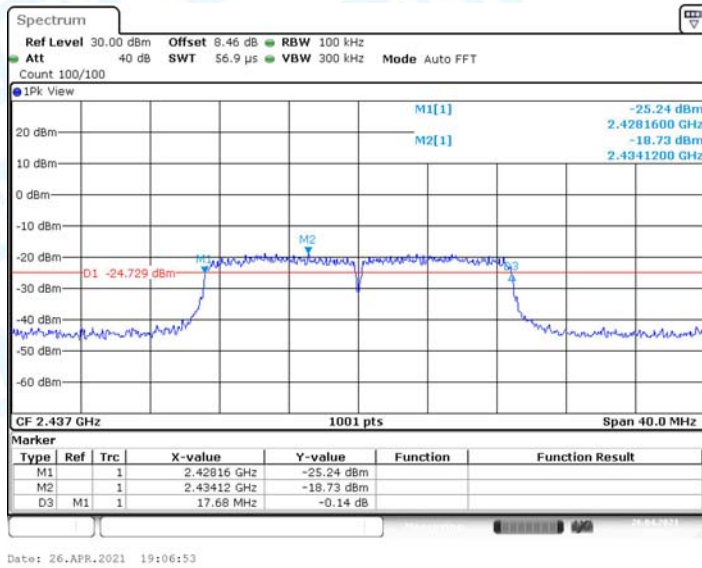

11N20MIMO\_Ant.A\_2462

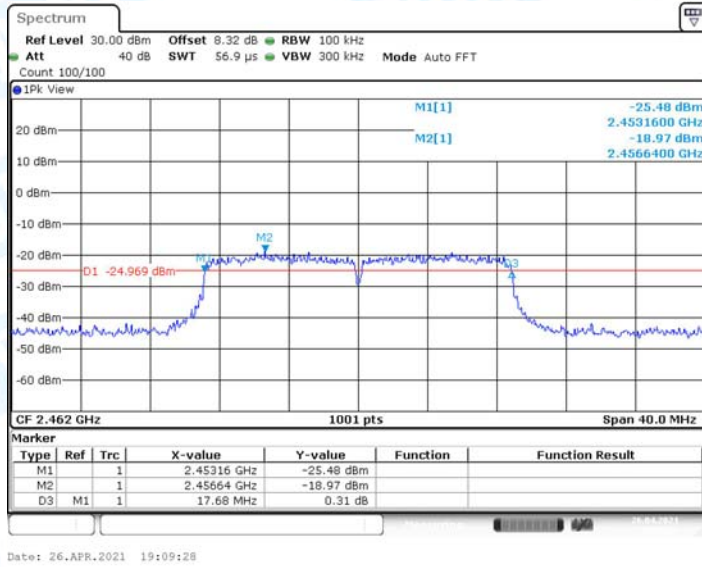

11N20MIMO\_Ant.B\_2462

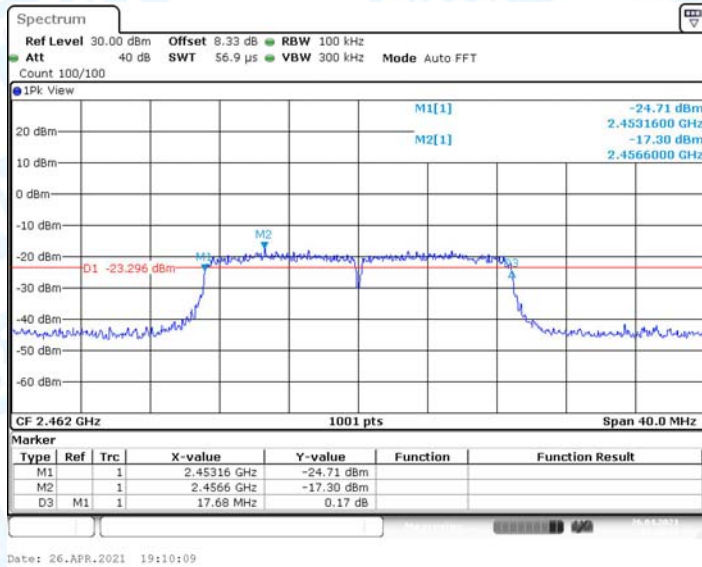

11N40MIMO\_Ant.A\_2422

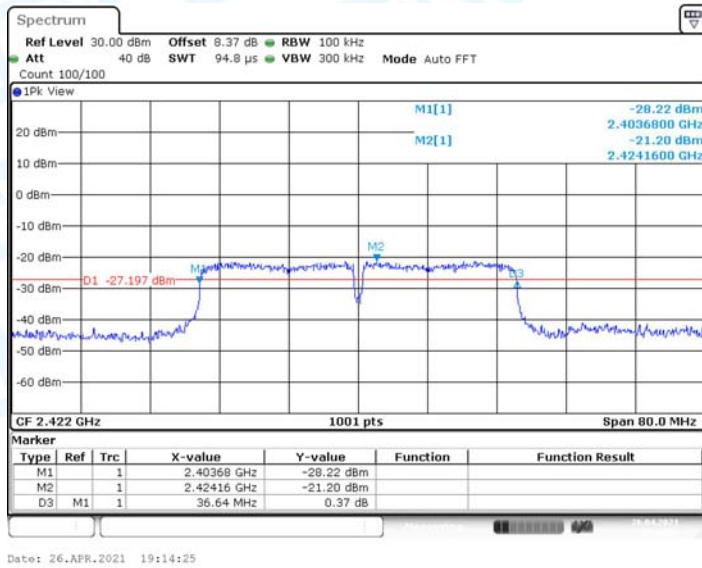

11N40MIMO\_Ant.B\_2422

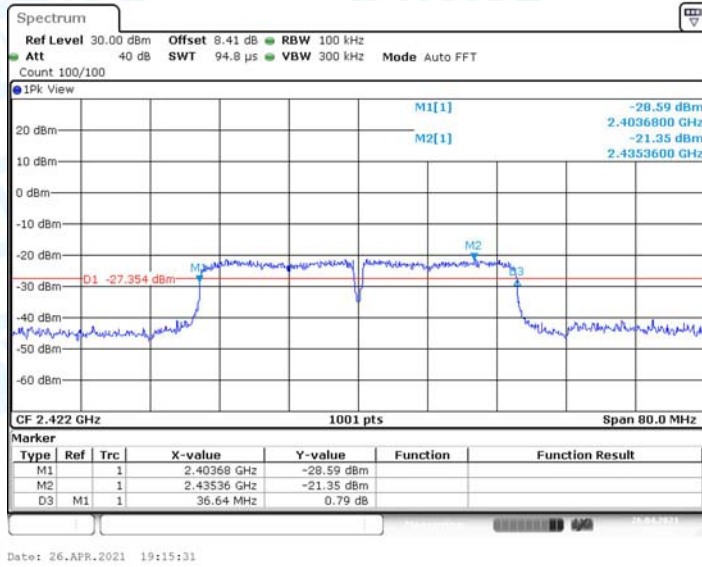

11N40MIMO\_Ant.A\_2437

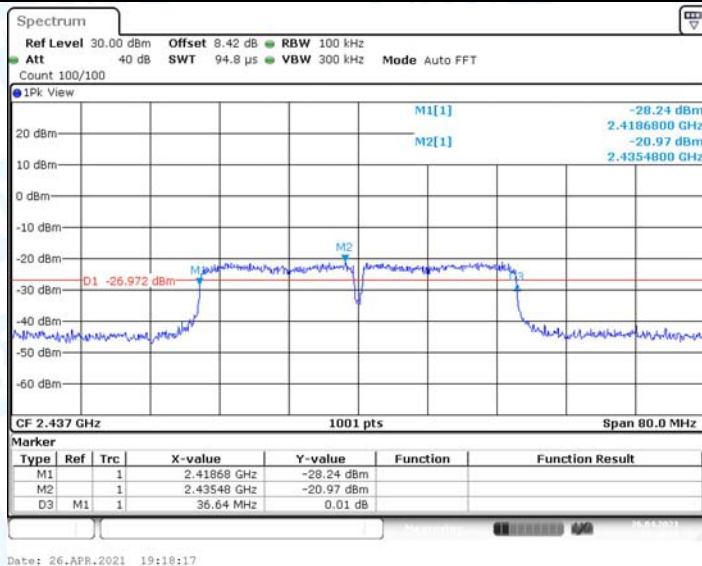

11N40MIMO\_Ant.B\_2437

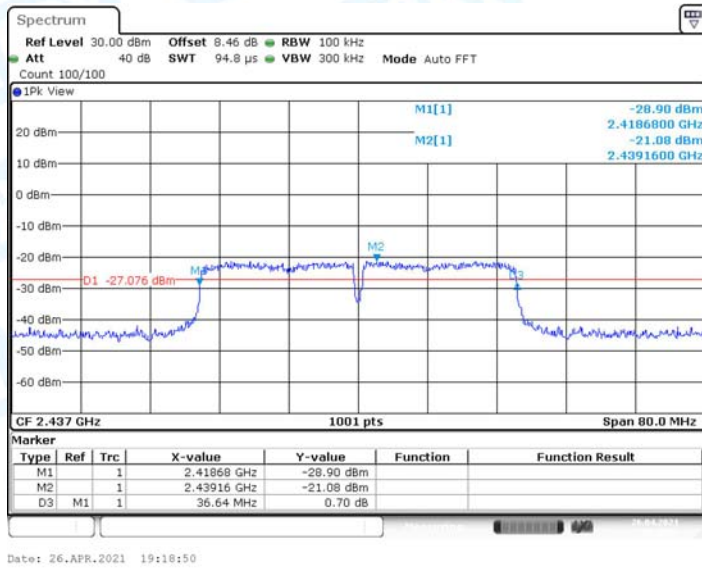

11N40MIMO\_Ant.A\_2452

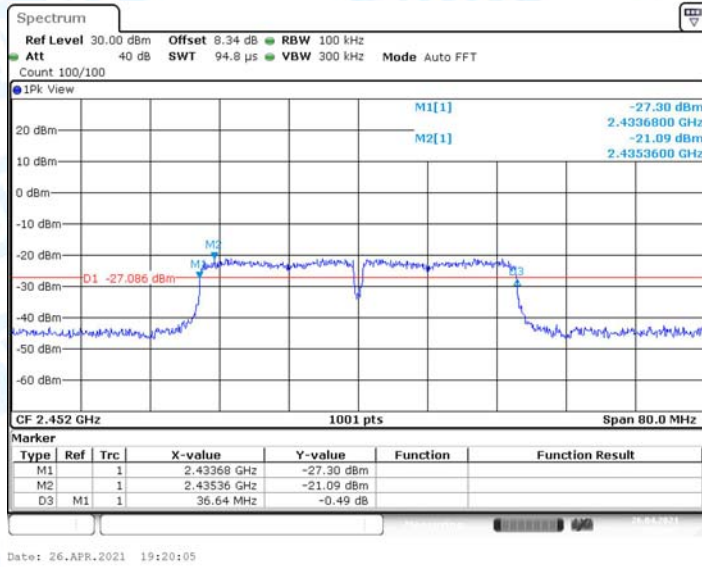

11N40MIMO\_Ant.B\_2452

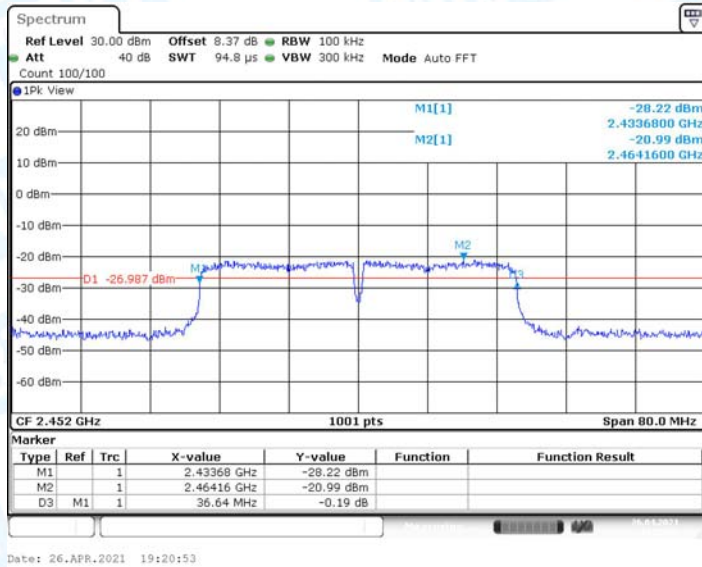

## Attachment E-- Peak Output Power Data

Test Mode	Antenna	Channel	Power [dBm]	Limit [dBm]	Verdict
11B	Ant.A	2412	4.07	<=30	PASS
	Ant.B	2412	3.97	<=30	PASS
	Ant.A	2437	3.42	<=30	PASS
	Ant.B	2437	3.99	<=30	PASS
	Ant.A	2462	2.73	<=30	PASS
	Ant.B	2462	4.23	<=30	PASS
11G	Ant.A	2412	3.53	<=30	PASS
	Ant.B	2412	4.17	<=30	PASS
	Ant.A	2437	3.97	<=30	PASS
	Ant.B	2437	4.06	<=30	PASS
	Ant.A	2462	4.13	<=30	PASS
	Ant.B	2462	4.08	<=30	PASS
11N20MIMO	Ant.A	2412	3.13	<=30	PASS
	Ant.B	2412	3.16	<=30	PASS
	<b>total</b>	<b>2412</b>	<b>6.2</b>	<b>&lt;=30</b>	<b>PASS</b>
	Ant.A	2437	2.73	<=30	PASS
	Ant.B	2437	2.86	<=30	PASS
	<b>total</b>	<b>2437</b>	<b>5.8</b>	<b>&lt;=30</b>	<b>PASS</b>
	Ant.A	2462	2.58	<=30	PASS
	Ant.B	2462	3.53	<=30	PASS
	<b>total</b>	<b>2462</b>	<b>6.1</b>	<b>&lt;=30</b>	<b>PASS</b>
11N40MIMO	Ant.A	2422	3.51	<=30	PASS
	Ant.B	2422	3.57	<=30	PASS
	<b>total</b>	<b>2422</b>	<b>6.6</b>	<b>&lt;=30</b>	<b>PASS</b>
	Ant.A	2437	3.50	<=30	PASS
	Ant.B	2437	3.59	<=30	PASS
	<b>total</b>	<b>2437</b>	<b>6.6</b>	<b>&lt;=30</b>	<b>PASS</b>
	Ant.A	2452	3.44	<=30	PASS
	Ant.B	2452	3.45	<=30	PASS
	<b>total</b>	<b>2452</b>	<b>6.5</b>	<b>&lt;=30</b>	<b>PASS</b>



Duty Cycle		
Mode	Channel frequency (MHz)	Test Result
802.11b	2412	>98%
	2437	
	2462	
802.11g	2412	
	2437	
	2462	
802.11n (HT20)	2412	
	2437	
	2462	
802.11n (HT40)	2422	
	2437	
	2452	

Please see below plots

Test Graphs

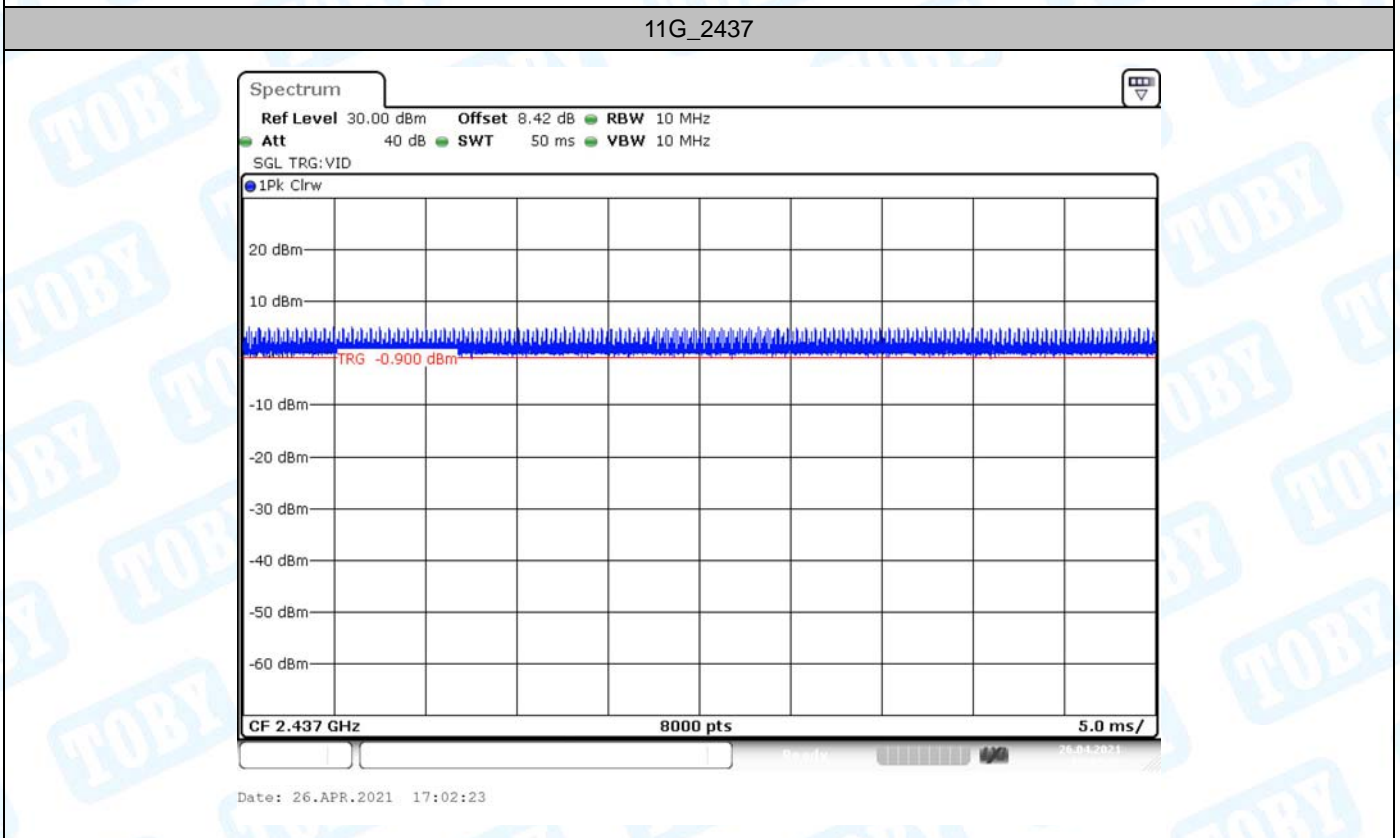
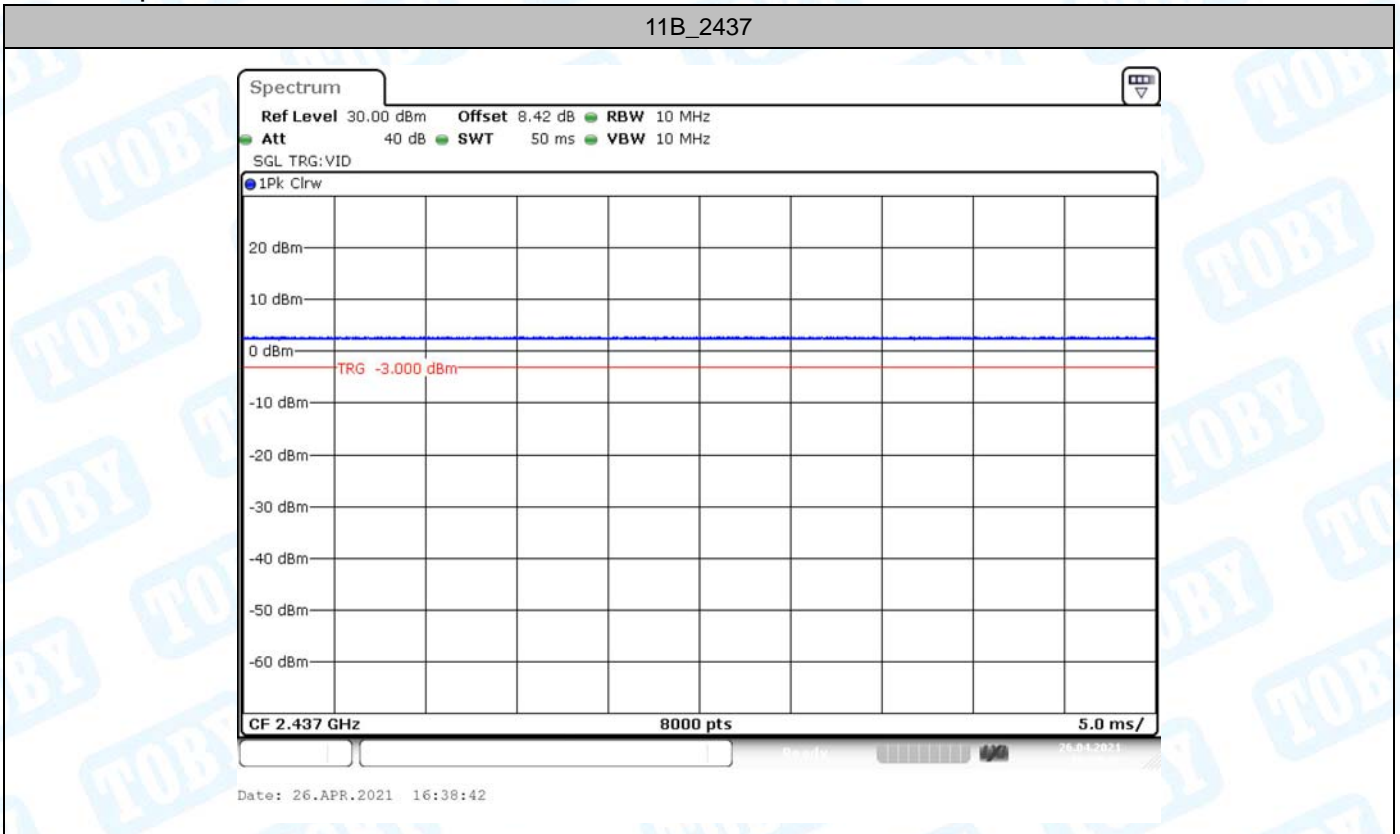

11N20MIMO\_2437

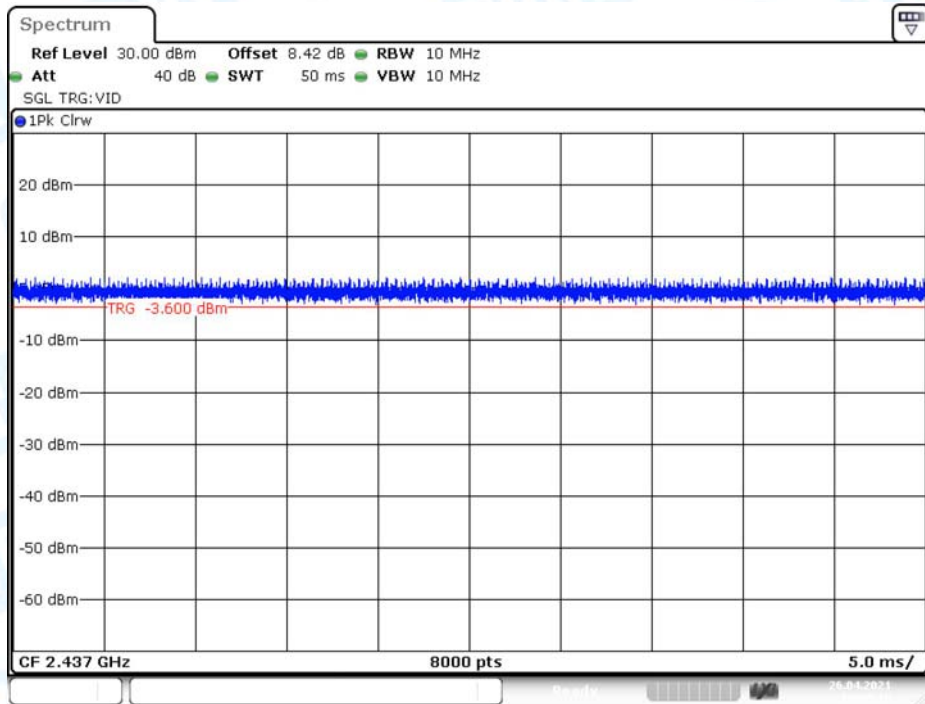

Date: 26.APR.2021 19:05:19

11N40MIMO\_2437

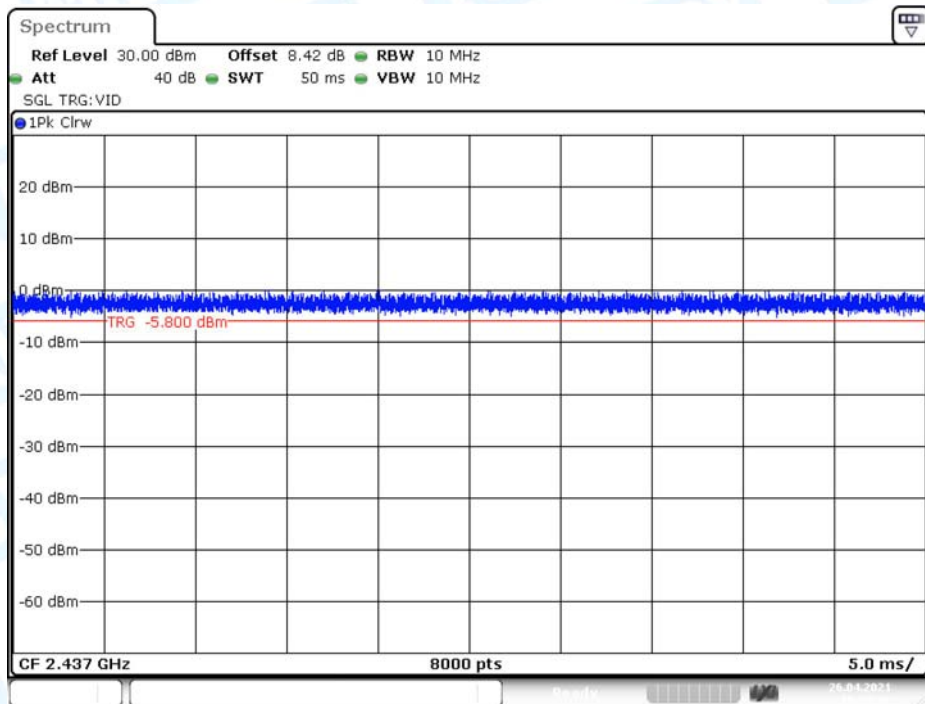

Date: 26.APR.2021 19:18:07

## Attachment F-- Power Spectral Density Test Data

Test Mode	Antenna	Channel	Result [dBm/3kHz]	Limit[dBm/3kHz]	Verdict
11B	Ant.A	2412	-29.66	<=8	PASS
	Ant.B	2412	-29.74	<=8	PASS
	Ant.A	2437	-30.38	<=8	PASS
	Ant.B	2437	-29.81	<=8	PASS
	Ant.A	2462	-31.09	<=8	PASS
	Ant.B	2462	-29.56	<=8	PASS
11G	Ant.A	2412	-32.3	<=8	PASS
	Ant.B	2412	-31.57	<=8	PASS
	Ant.A	2437	-32.17	<=8	PASS
	Ant.B	2437	-24.62	<=8	PASS
	Ant.A	2462	-32.12	<=8	PASS
	Ant.B	2462	-25.25	<=8	PASS
11N20MIMO	Ant.A	2412	-32.41	<=8	PASS
	Ant.B	2412	-32.45	<=8	PASS
	<b>total</b>	<b>2412</b>	<b>-29.42</b>	<b>&lt;=8</b>	<b>PASS</b>
	Ant.A	2437	-32.64	<=8	PASS
	Ant.B	2437	-32.62	<=8	PASS
	<b>total</b>	<b>2437</b>	<b>-29.62</b>	<b>&lt;=8</b>	<b>PASS</b>
	Ant.A	2462	-32.85	<=8	PASS
	Ant.B	2462	-31.91	<=8	PASS
	<b>total</b>	<b>2462</b>	<b>-29.34</b>	<b>&lt;=8</b>	<b>PASS</b>
11N40MIMO	Ant.A	2422	-32.78	<=8	PASS
	Ant.B	2422	-33.17	<=8	PASS
	<b>total</b>	<b>2422</b>	<b>-29.96</b>	<b>&lt;=8</b>	<b>PASS</b>
	Ant.A	2437	-34.01	<=8	PASS
	Ant.B	2437	-28.94	<=8	PASS
	<b>total</b>	<b>2437</b>	<b>-27.76</b>	<b>&lt;=8</b>	<b>PASS</b>
	Ant.A	2452	-32.93	<=8	PASS
	Ant.B	2452	-33.63	<=8	PASS
	<b>total</b>	<b>2452</b>	<b>-30.26</b>	<b>&lt;=8</b>	<b>PASS</b>

Test Graphs

11B\_Ant.A\_2412

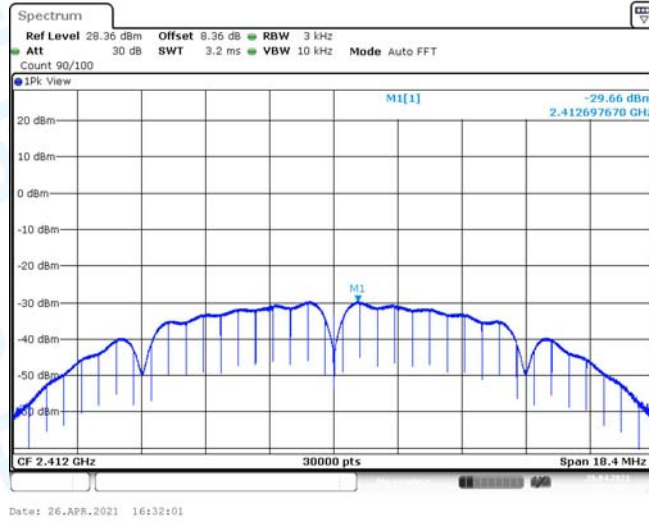

11B\_Ant.B\_2412

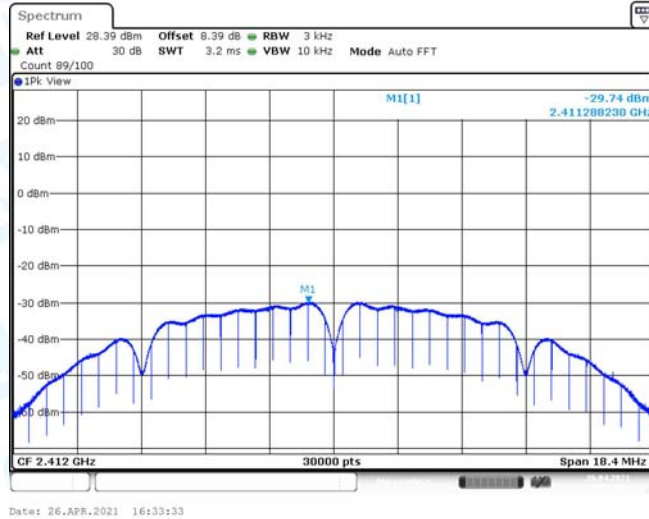

11B\_Ant.A\_2437



11B\_Ant.B\_2437

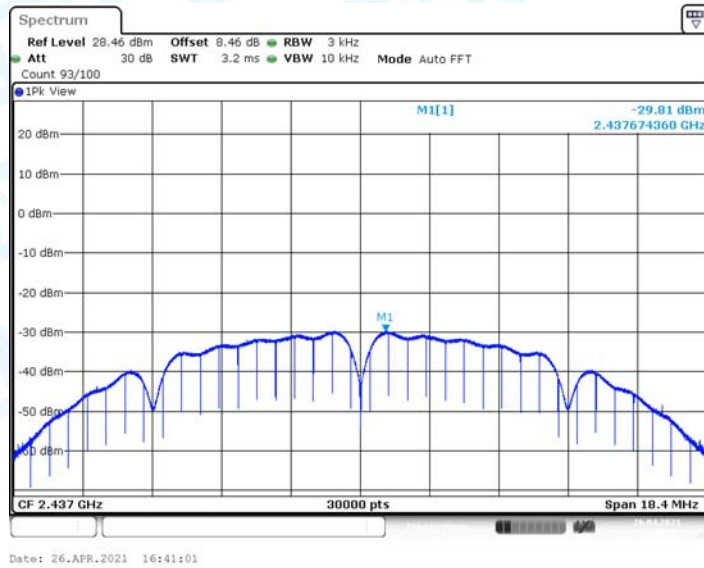

11B\_Ant.A\_2462

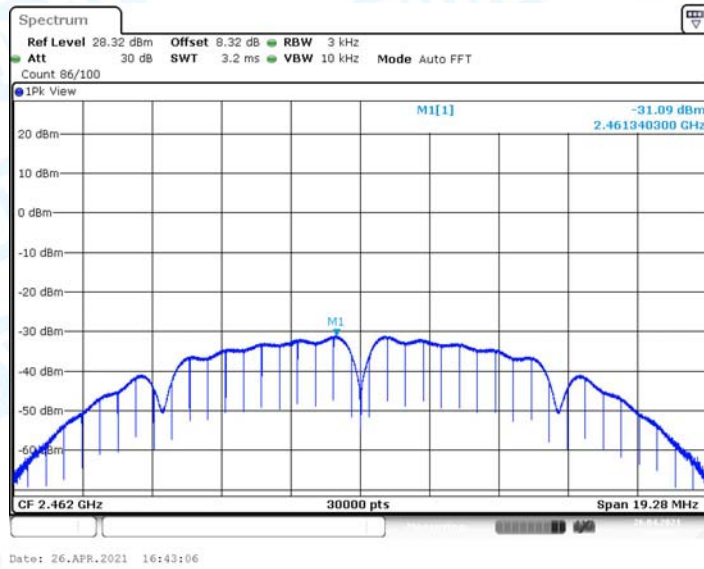

11B\_Ant.B\_2462

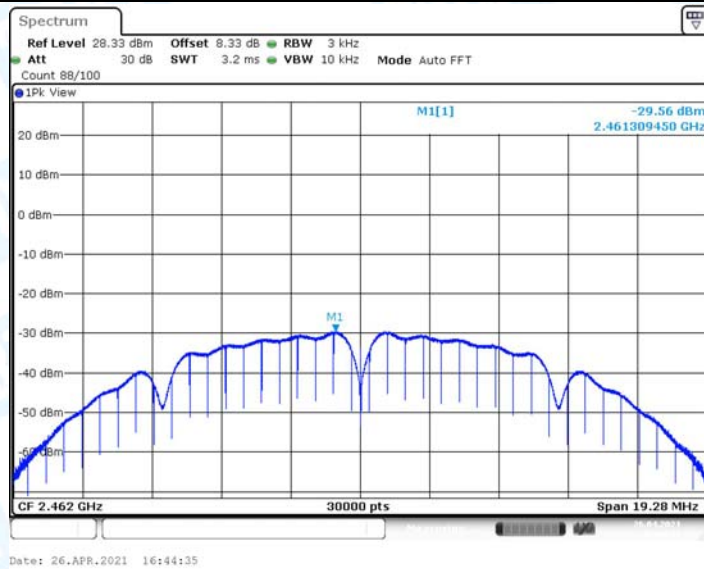

11G\_Ant.A\_2412

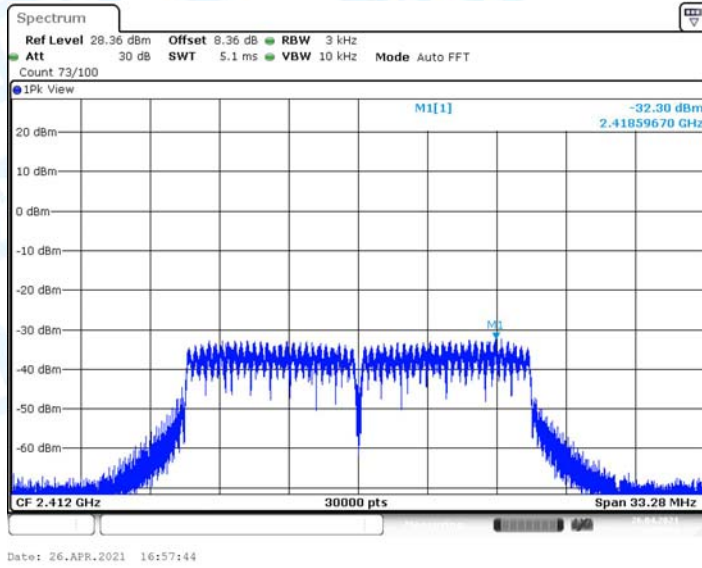

11G\_Ant.B\_2412

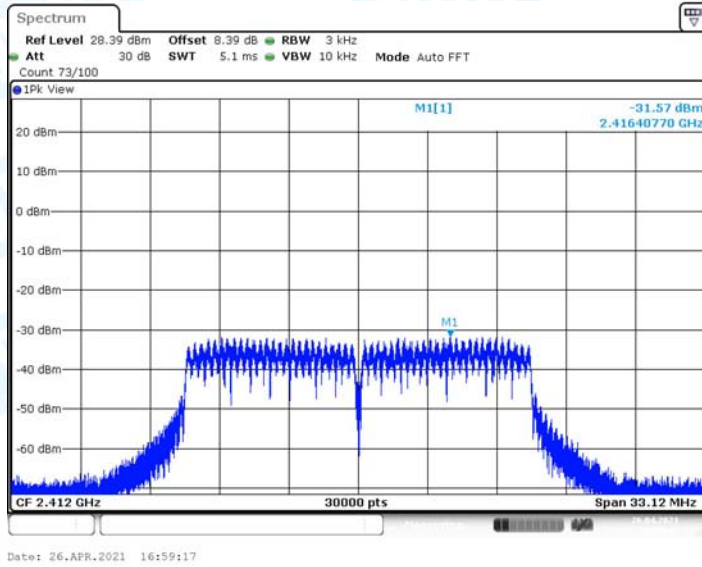

11G\_Ant.A\_2437

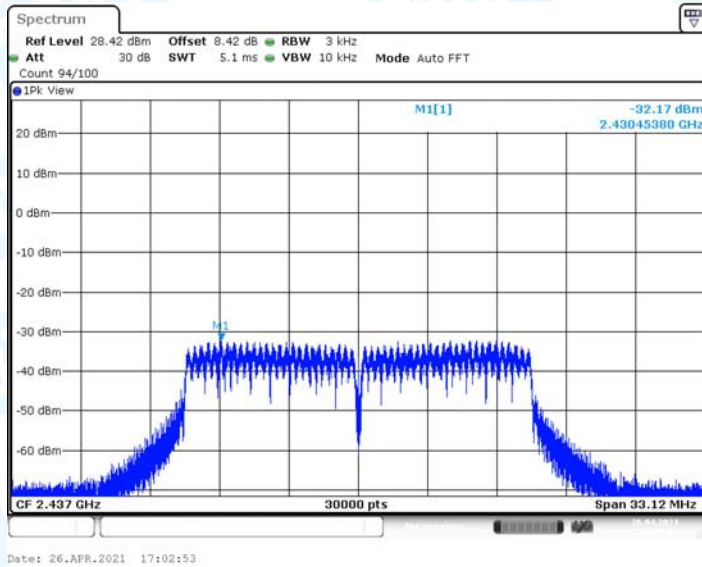

11G\_Ant.B\_2437

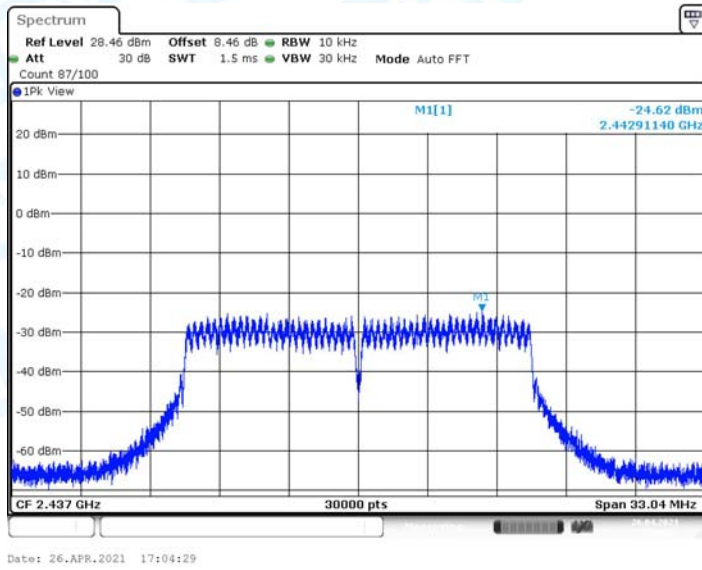

11G\_Ant.A\_2462

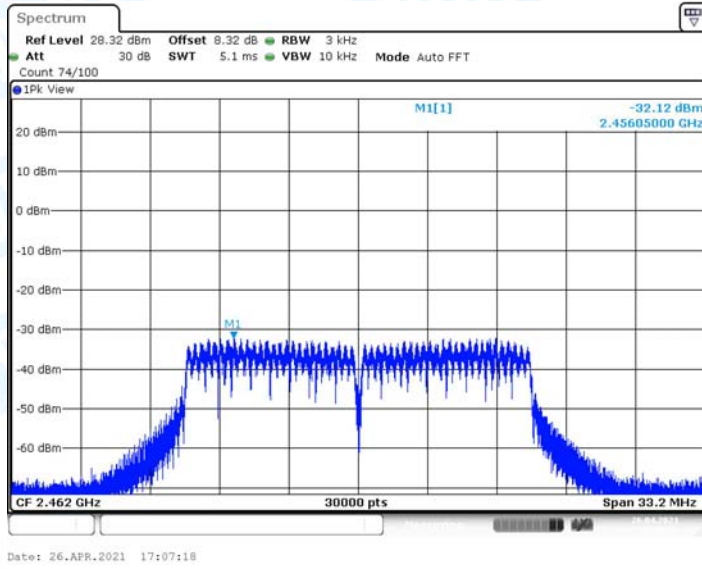

11G\_Ant.B\_2462

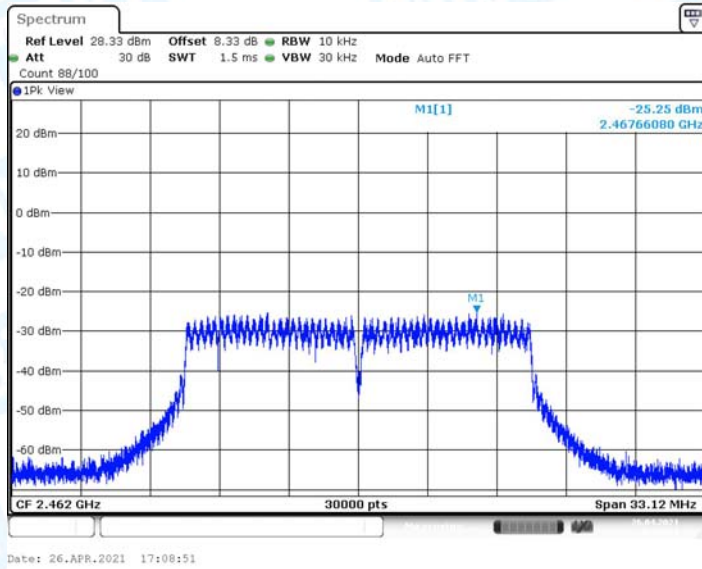



11N20MIMO\_Ant.A\_2412

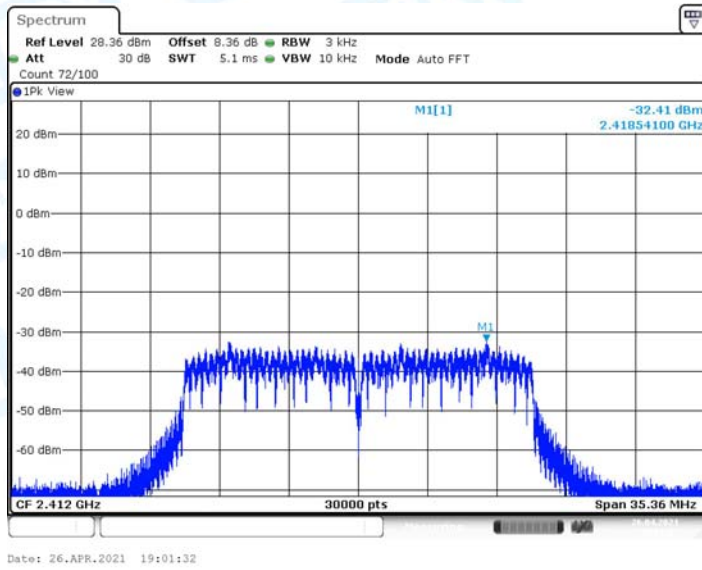

11N20MIMO\_Ant.B\_2412

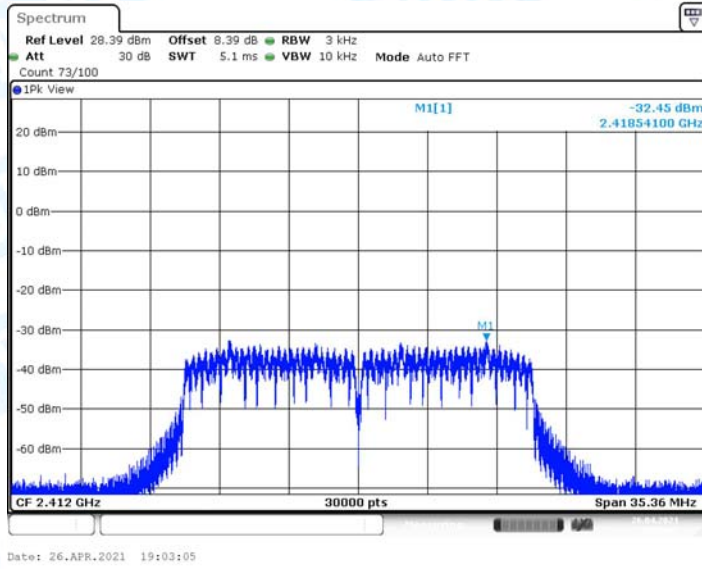

11N20MIMO\_Ant.A\_2437

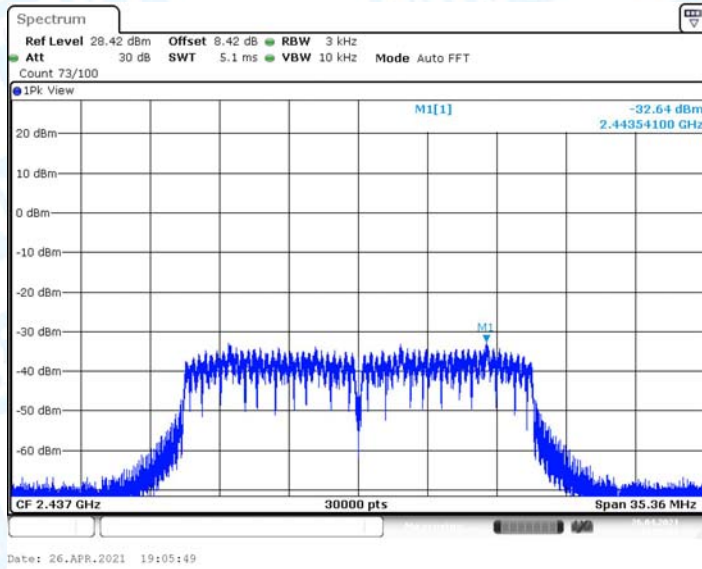

11N20MIMO\_Ant.B\_2437

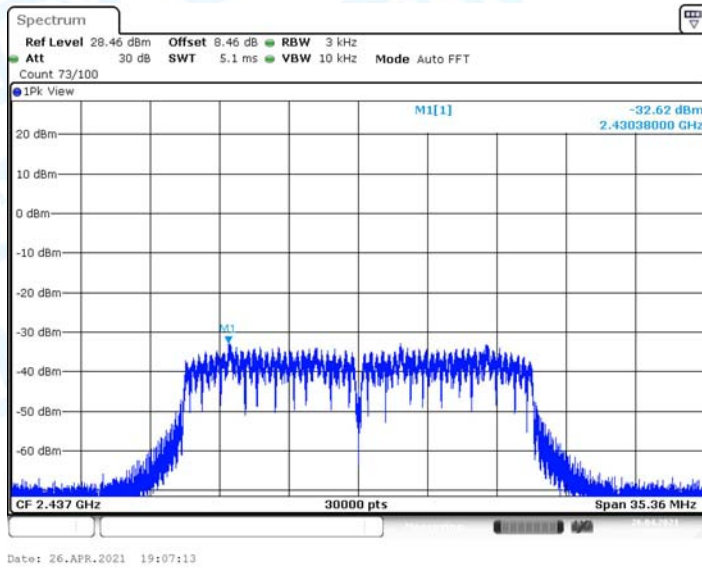

11N20MIMO\_Ant.A\_2462

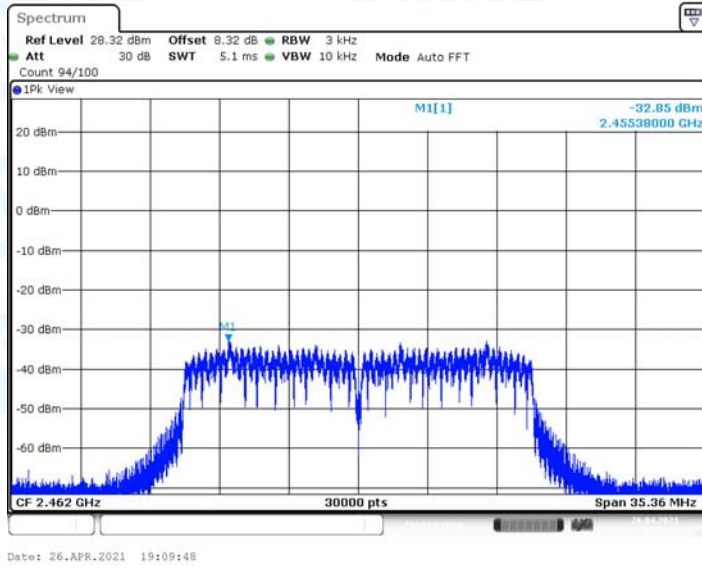

11N20MIMO\_Ant.B\_2462

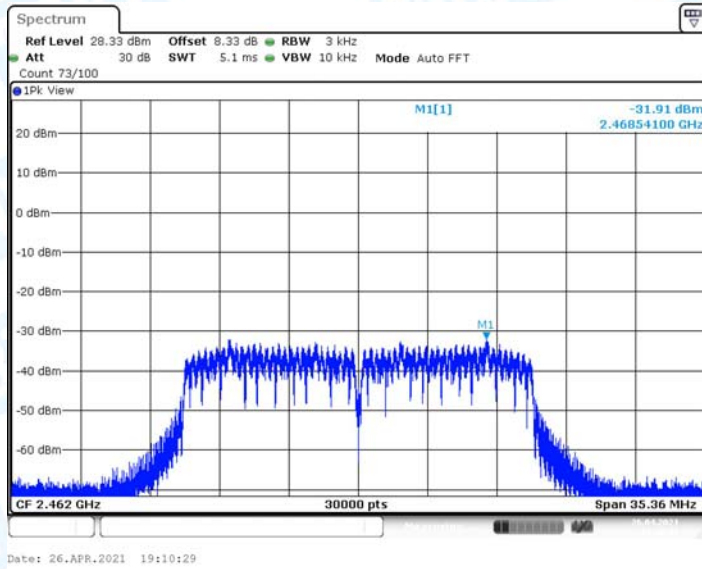



11N40MIMO\_Ant.B\_2437

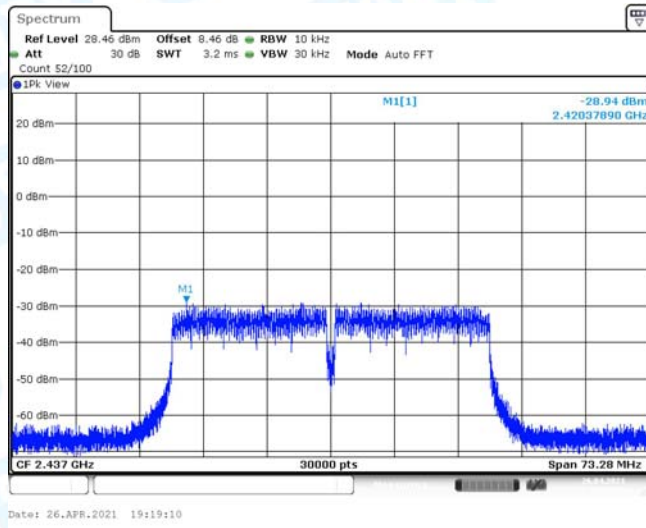

11N40MIMO\_Ant.A\_2452

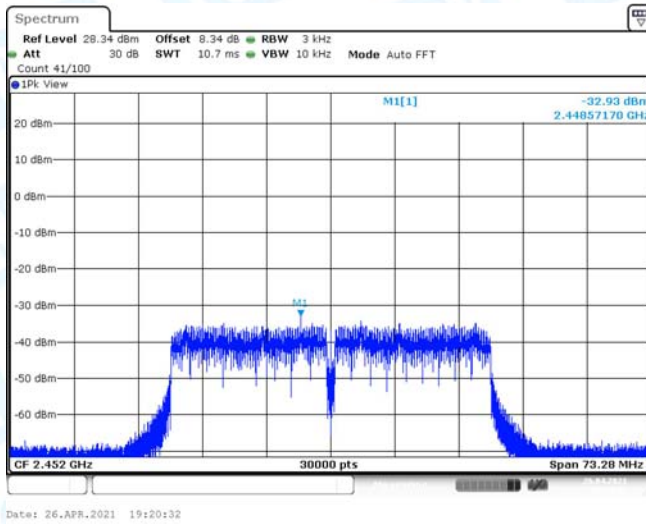

11N40MIMO\_Ant.B\_2452

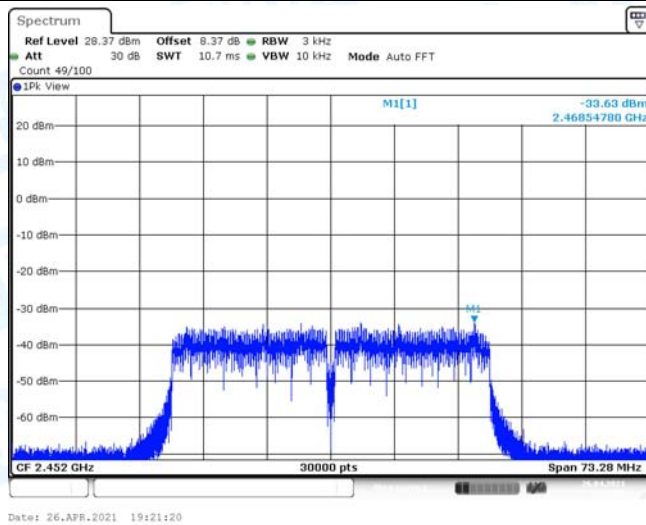

-----END OF REPORT-----