



Ke Mei Ou Lab Corp.

E506, 5th Floor, No.39 Keji Middle 2nd Rd, Science & Technology
Park, Nanshan District, Shenzhen, P. R. China
Tel: + 86 755 83642690 Fax: + 86 755 83297077
www.kmolab.com

FCC TEST REPORT

Under
FCC 15 Subpart C, Paragraph 15.247

Operating in 2400 ~ 2483.5 MHz Band

Prepared For :

Shenzhen Four Seas Global Link Network Technology Co., Ltd.

Room 607-610, Block B, TAOJINDI Electronic Business Incubation Base, Tenglong Road,
Longhua District, Shenzhen, China.

FCC ID: OYRCF-912AC
EUT: Wireless Adapter
Model: CF-912AC

December 11, 2015
Issue Date:
Original Report
Report Type:
<i>Eric Guo</i>
Test Engineer:

Review By: Apollo Liu / Manager

The test report consists 71 pages in total. It may be duplicated completely for legal use with the allowance of the applicant. It shall not be reproduced except in full, without the written approval of Ke Mei Ou Laboratory Corporation. The test result in the report only applied to the tested sample.

TABLE OF CONTENTS

1. General Information	3
1. 1 Notes.....	3
1. 2 Testing Laboratory.....	3
1. 3 Details of Applicant.....	3
1. 4 Application Details	3
1. 5 Test Item	3
1. 6 Test Standards.....	3
2. Technical Test.....	4
2. 1 Summary of Test Results	4
2. 2 Antenna Requirement	4
3. EUT Modifications	4
4. Conducted Power Line Test.....	5
4. 1 Test Equipment.....	5
4. 2 Test Procedure	5
4. 3 Test Setup	5
4. 4 Configuration of the EUT.....	6
4. 5 EUT Operating Condition.....	8
4. 6 Conducted Power Line Emission Limits	8
4. 7 Conducted Power Line Test Result.....	9
5. FCC Part 15.247 Requirements for 802.11b/g/n Systems.....	11
5. 1 Test Equipment	11
5. 2 Test Procedure	11
5. 3 Test Setup	11
5. 4 Configuration of the EUT.....	11
5. 5 EUT Operating Condition.....	11
5. 6 Limit	12
5. 7 Test Result	13
6. Transmitter Spurious Radiated Emission at 3 Meters.....	40
6. 1 Test Equipment.....	40
6. 2 Test Procedure	40
6. 3 Test Setup	40
6. 4 Configuration of the EUT.....	41
6. 5 EUT Operating Condition.....	41
6. 6 Limit	42
6. 7 Test Result	43
7. RF Exposure Requirements	62
7. 1 Test Equipment.....	62
7. 2 Limit	62
7. 3 Test Result	62
8. Photos of Testing.....	63
8. 1 EUT Test Photographs.....	63
8. 2 EUT Detailed Photographs.....	65
9. FCC ID Label.....	70
10. Test Equipment.....	71

1. General Information

1.1 Notes

The test results of this report relate exclusively to the test item specified in 1.5. The KMO Lab does not assume responsibility for any conclusions and generalizations drawn from the test results with regard to other specimens or samples of the type of the equipment represented by the test item. The test report may only be reproduced or published in full. Reproduction or publication of extracts from the report requires the prior written approval of the KMO Lab.

1.2 Testing Laboratory

Ke Mei Ou Laboratory Co., Ltd.

ANSI-ASQ National Accreditation Board/ACLASS ISO/IEC 17025 Accredited Lab for telecommunication standards. The Registration Number is AT-1532. The testing quality system meets with ISO/IEC-17025 requirements, This approval results is accepted by MRA of ILAC.

FCC Test Site Registration Number: 962205

IC Test Site Registration Number: 4986A-2

Internet: www.kmolab.com

1.3 Details of Applicant

Name : Shenzhen Four Seas Global Link Network Technology Co., Ltd.
Address : Room 607-610, Block B, TAOJINDI Electronic Business Incubation Base, Tenglong Road, Longhua District, Shenzhen, China.

1.4 Application Details

Date of Receipt of Application : October 28, 2015
 Date of Receipt of Test Item : October 28, 2015
 Date of Test : November 13~November 26, 2015

1.5 Test Item

Manufacturer : Shenzhen Four Seas Jialan Electronic Technology Co., Ltd.
 Address : Floor 4, Building 9, Hongxin Industrial Park, Da Bu Xiang Community
 Guanlan Street, Bao'an District Shenzhen, China
 Trade Name : COMFAST
 Model No.(Base) : CF-912AC
 Model No.(Extension) : N/A
 Description : Wireless Adapter

Additional Information

Product Type : WLAN (2TX, 2RX)
 Radio Type : Intentional Transceiver
 Power Type : DC 5V(From Host)
 Modulation : see the below tables
 Data Modulation : IEEE 802.11b: DQPSK, DBPSK, DSSS, and CCK
 IEEE 802.11g: BPSK, QPSK, 16QAM, 64QAM
 IEEE 802.11n 2.4G: HT20/40: OFDM (64QAM,16QAM, QPSK, BPSK)
 Date Rate (Mbps) : see the below table
 Frequency Range : 2412~2462MHz-802.11b/g/n 2.4G
 Channel Number : IEEE 802.11b/g/n 2.4G: HT20: 11Channels HT40: 7Channels
 Antenna : Internal 2.4G: 3.5dBi
 802.11b/g/n 2.4G

Antenna	Single (TX)		Two (TX)	
	20 MHz	40 MHz	20 MHz	40 MHz
Band width Mode	20 MHz	40 MHz	20 MHz	40 MHz
802.11b / 11,5.5,2 and 1 Mbps with auto-rate fall back	√	X	X	X
802.11g / 54,48,36,24,18,12,9&6 Mbps	√	X	X	X
Draft n 2.4G / up to 72Mbps	√	√	√	√

1.6 Test Standards

FCC 15 Subpart C, Paragraph 15.247

Note: All radiated measurements were made in all three orthogonal planes. The values reported are the maximum values.

2. Technical Test

2.1 Summary of Test Results

The EUT has been tested according to the following specifications:

FCC Rule	Test Type	Limit	Result	Notes
FCC 15.247(a)(2)	6dB Bandwidth	$\geq 0.5\text{MHz}$	PASS	Complies
FCC 15.247(b)(1)	Peak Output Power	$\leq 30\text{dBm}$	PASS	Complies
FCC 15.247(e)	Power Spectral Density	$\leq 8\text{dBm}$	PASS	Complies
FCC 15.247(d)	Conducted Band Edges and Spurious Emission	$\leq 20\text{dBc}$	PASS	Complies.
FCC 15.247(d)	Radiated Band Edges and Spurious Emission	FCC 15.209(a) & 15.247(d)	PASS	Complies.
FCC 15.207	AC Conducted Emission	FCC15.207(a)	PASS	Complies.
FCC 15.203 & 15.247(b)	Antenna Requirement	N/A	PASS	Complies

* The digital circuit porting of the EUT has been tested and verified to comply with FCC Part 15, Subpart B., Class B Digital Devices and the associated Radio Receiver has also been tested and found to comply with FCC Part 15, Subpart B – Radio Receivers.

2.2 Antenna Requirement

A. Regulation

FCC section 15.203, An intentional radiator shall be designed to ensure that no antenna other than that furnished by the responsible party shall be used with the device. The use of a permanently attached antenna or of an antenna that uses a unique coupling to the intentional radiator shall be considered sufficient to comply with the provisions of Part 15C. The manufacturer may design the unit so that the user can replace a broken antenna, but the use of a standard antenna jack or electrical connector is prohibited. This requirement does not apply to carrier current devices or to devices operated under the provisions of Sections 15.211, 15.213, 15.217, 15.219, or 15.221. Further, this requirement does not apply to intentional radiators that must be professionally installed, such as perimeter protection systems and some field disturbance sensors, or to other intentional radiators which, in accordance with Section 15.31(d), must be measured at the installation site. However, the installer shall be responsible for ensuring that the proper antenna is employed so that the limits in this Part are not exceeded.

B. Result

The antenna type used in this product is internal Antenna and fixed in the EUT and without connector. That no antenna other than furnished by the responsible party shall be used with the device. The EUT as tested meets the criteria of this rule by being antenna being permanently attached and professionally installed. The EUT is compliant with Section 15.203.

3. EUT Modifications

No modification by test lab.

4. Conducted Power Line Test

4.1 Test Equipment

Please refer to Section 10 this report.

4.2 Test Procedure

The EUT and simulators are connected to the main power through a line impedance stabilization network (L.I.S.N.). This provides a 50 ohm/50uH coupling impedance for the measuring equipment. The peripheral devices are also connected to the main power through a LISN that provides a 50ohm/50uH coupling impedance with 50ohm termination.

Both sides of A.C. line are checked for maximum conducted interference. In order to find the maximum emission., the relative positions of equipment and all of the interface cables must be changed according to ANSI C63.10:2013 on conducted measurement. Conducted emissions were investigated over the frequency range from 0.15MHz to 30MHz using a receiver bandwidth of 9kHz.

4.3 Test Setup

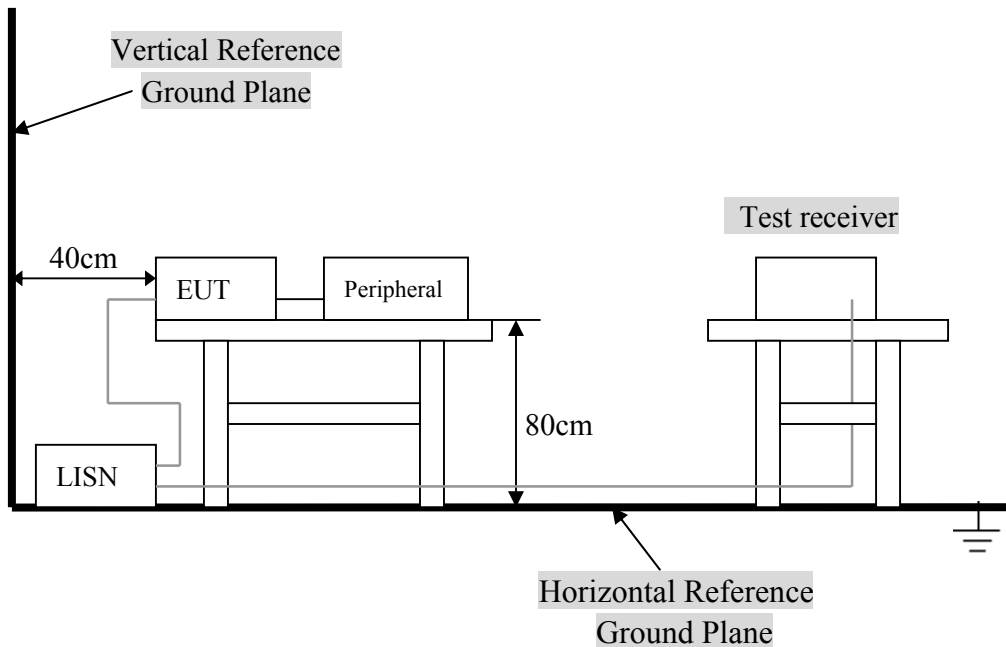

For the actual test configuration, Please refer to the related items – Photos of Testing.

4.4 Configuration of the EUT

The EUT was configured according to ANSI C63.10:2013 . EUT was used DC5V from host. The operation frequency is from 2412MHz~2462MHz. Enable the signal transmitted from the EUT to Notebook PC. All interface ports were connected to the appropriate peripherals. All peripherals and cables are listed below.

A. EUT

Device	Manufacturer	Model #	FCC ID
Wireless Adapter	Shenzhen Four Seas Jialan Electronic Technology Co., Ltd.	CF-912AC	OYRCF-912AC

Field Antenna For 2.4GHz Band

Ant.	Brand	Model Name	Antenna Type	Connector	Gain (dBi)	Remark
0,1	N/A	WIFI PCB Antenna	Internal	N/A	3.50	TX/RX

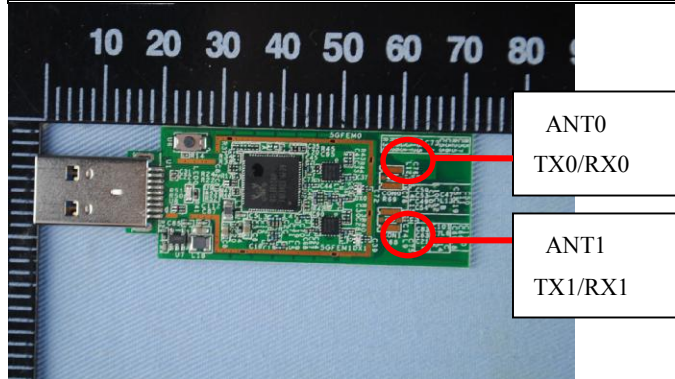

Note:

The EUT incorporates a MIMO function with 802.11b, 802.11g, 802.11n. Physically, the EUT provides two completed transmit and two receiver. The device was tested in a MIMO type operation.

802.11b/g/n Carrier Frequencies For 2.4GHz Band

Frequency Band	Channel No.	Frequency	Channel No.	Frequency
2400~2483.5Mhz	1	2412MHz	7	2442MHz
	2	2417MHz	8	2447MHz
	3	2422MHz	9	2452MHz
	4	2427MHz	10	2457MHz
	5	2432MHz	11	2462MHz
	6	2437MHz		

Test Modes For 2.4GHz Band

Test Items	Mode	Data Rate	Channel	Antenna
AC Power Line Conducted Emissions	Normal Link	Auto	-	-
Maximum Peak Conducted Output Power Power Spectral Density 6dB Spectrum Bandwidth	MCS0/20MHz	7.2 Mbps	1/6/11	0
	MCS0/40MHz	15 Mbps	3/6/9	-
	11b/BPSK	1 Mbps	1/6/11	0
	11g/BPSK	6 Mbps	1/6/11	0
Radiated Emissions 9kHz~1GHz	Normal Link	Auto	-	-
Radiated Emissions 1GHz~10 th Harmonic	MCS0/20MHz	7.2 Mbps	1/6/11	0
	MCS0/40MHz	15 Mbps	3/6/9	-
	11b/BPSK	1 Mbps	1/6/11	0
	11g/BPSK	6 Mbps	1/6/11	0
Band Edge Emissions	MCS0/20MHz	7.2 Mbps	1/11	0
	MCS0/40MHz	15 Mbps	3/9	-
	11b/BPSK	1 Mbps	1/11	0
	11g/BPSK	6 Mbps	1/11	0

Note: Preliminary tests were performed in different data rate to find the worst radiated emission. The data rate show in the table above is the worst-case rate with respect to the specific test item. Investigation has been done on all the possible configurations for searching the worst cases. During testing, Channel & Power Controlling Software provided by the customer was used to control the operating channel as well as the output power level, The RF output power selection is for the setting of RF output power expected by the customer and is going to be fixed on the firmware of the final end product.

B. Internal Devices

Device	Manufacturer	Model #	FCC ID
N/A			

C. Peripherals

Device	Manufacturer	Model # Serial #	FCC ID/ DoC	Cable
Printer	HP	HP930C	DoC	1.5m unshielded power cord 1.2m unshielded data cable.
Mouse	DELL	OCJ339	DoC	1.2m unshielded cable
Notebook	DELL	PP10L	DoC	1.5m unshielded power cord
PC	DELL	2400n	DoC	1.5m unshielded power cord

4. 5 EUT Operating Condition

Operating condition is according to ANSI C63.10:2013.

- A. Setup the EUT and simulators as shown on follow.
- B. Enable RF signal and confirm EUT active.
- C. Modulate output capacity of EUT up to specification.

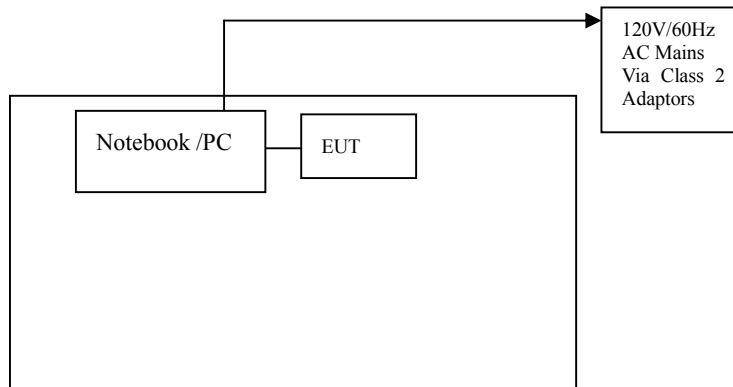

4. 6 Conducted Power Line Emission Limits

FCC Part 15 Paragraph 15.207 (dBuV)		
Frequency Range (MHz)	Class A QP/AV	Class B QP/AV
0.15 – 0.5	79/66	66-56/56-46
0.5 – 5.0	73/60	56/46
5.0 - 30	73/60	60/50

NOTE : In the above table, the tighter limit applies at the band edges.

4.7 Conducted Power Line Test Result

Product	: Wireless Adapter	Test Mode	: Normal
Test Item	: Conducted Emission Data	Temperature	: 25 °C
Test Voltage	: DC 5V(From Host)	Humidity	: 56%RH
Test Result	: PASS		

The frequency spectrum from 0.15 MHz to 30 MHz was investigated. All readings are quasi -peak values with a resolution bandwidth of 9 KHz.

- Temperature : 26 °C
- Humidity : 53 % RH

FCC Part 15 Paragraph 15.207							
Frequency (MHz)	Emission (dBuV)		LINE/NEUTRAL	Limit (dBuV)		Margin (dB)	
	QP	AV		QP	AV	QP	AV
0.154	46.89	30.31	Line	65.78	55.78	-18.89	-25.47
0.162	45.93	29.34	Neutral	65.36	55.36	-19.43	-26.02
0.182	51.58	38.25	Line	64.39	54.39	-12.81	-16.14
0.178	51.89	40.23	Neutral	64.58	54.58	-12.69	-14.35
0.194	50.16	36.49	Line	63.86	53.86	-13.70	-17.37
0.198	49.55	36.78	Neutral	63.69	53.69	-14.14	-16.91

Note: NF = No Significant Peak was Found.

Note:

- 1.Uncertainty in conducted emission measured is <+/-2dB.
- 2.The emission levels of other frequencies were very low against the limit.
- 3.All Reading Levels are Quasi-Peak and Average value.
- 4.Emission = Meter Reading + Factor; Factor = Insertion Loss + Cable Loss.
- 5.Margin Value = Emission Level - Limit Value.

Conducted Emission

FCC 15.207

Test Specification: LINE&NEUTRAL

Comment:



Date: 16.NOV.2015 13:40:38

5. FCC Part 15.247 Requirements for 802.11b/g/n Systems

5.1 Test Equipment

Please refer to Section 10 this report.

5.2 Test Procedure

6 dB & 99% Bandwidth	Refer to FCC 15.247(a)(2), ANSI C63.10:2013
Test Method:	FCC KDB Publication No. 558074 D01 DTS Meas Guidance v03r03. - 8.1 Option 1
a) Set RBW = 100 kHz. b) Set the video bandwidth (VBW) $\geq 3 \times$ RBW. c) Detector = Peak. d) Trace mode = max hold. e) Sweep = auto couple. f) Allow the trace to stabilize.	g) Measure the maximum width of the emission that is constrained by the frequencies associated with the two outermost amplitude points (upper and lower frequencies) that are attenuated by 6 dB relative to the maximum level measured in the fundamental emission. *For 99% Bandwidth Measurement, the spectrum analyzer's resolution bandwidth (RBW) is set 30kHz and set the Video bandwidth (VBW) = 100kHz.
Peak Power:	Refer to FCC 15.247(b)(3), ANSI C63.10:2013
Test Method:	FCC KDB Publication No. 558074 D01 DTS Meas Guidance v03r03. - 9.1.2 PKPM1 Peak power meter method
The maximum peak conducted output power may be measured using a broadband peak RF power meter. The power meter shall have a video bandwidth that is greater than or equal to the DTS bandwidth and shall utilize a fast-responding diode detector.	
Peak Power Spectral Density:	Refer to FCC 15.247(e), ANSI C63.10:2013
Test Method:	FCC KDB Publication No. 558074 D01 DTS Meas Guidance v03r03. - 10.2 Method PKPSD
a) Set analyzer center frequency to DTS channel center frequency. b) Set the span to 1.5 times the DTS bandwidth. c) Set the RBW to: $3 \text{ kHz} \leq \text{RBW} \leq 100 \text{ kHz}$. d) Set the VBW $\geq 3 \times$ RBW. e) Detector = peak. f) Sweep time = auto couple.	g) Trace mode = max hold. h) Allow trace to fully stabilize. i) Use the peak marker function to determine the maximum amplitude level within the RBW. j) If measured value exceeds limit, reduce RBW (no less than 3 kHz) and repeat.
Band Edges Measurement:	Refer to FCC 15.247(d), ANSI C63.10:2013
Test Method:	FCC KDB Publication No. 558074 D01 DTS Meas Guidance v03r03. & 15.247
a. The transmitter output was connected to the spectrum analyzer via a low lose cable. b. Set both RBW and VBW of spectrum analyzer to 100kHz with suitable frequency span including 100kHz bandwidth from band edge. c. The band edges was measured and recorded.	

5.3 Test Setup

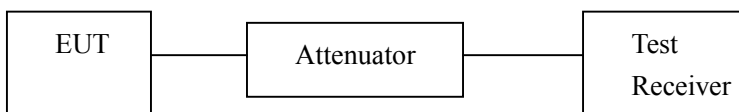

5.4 Configuration of the EUT

Same as section 4.4 of this report

5.5 EUT Operating Condition

Same as section 4.5 of this report.

5.6 Limit

According to §15.247(a)(2), systems using digital modulation techniques may operate in the 902 ~ 928 MHz, 2400 ~ 2483.5 MHz, and 5725 ~ 5850 MHz bands. The minimum 6dB bandwidth shall be at least 500 kHz.

According to §15.247(b)(3), for systems using digital modulation in the bands of 902-928 MHz, 2400-2483.5 MHz, and 5725-5850 MHz: 1 Watt.

According to §15.247(b)(4), the conducted output power limit specified in paragraph (b) of this section is based on the use of antennas with directional gains that do not exceed 6 dBi. Except as shown in paragraph (c) of this section, if transmitting antennas of directional gain greater than 6 dBi are used, the conducted output power from the intentional radiator shall be reduced below the stated values in paragraphs (b)(1), (b)(2), and (b)(3) of this section, as appropriate, by the amount in dB that the directional gain of the antenna exceeds 6 dBi.

According to §15.247(d), in any 100 kHz bandwidth outside the frequency bands in which the spread spectrum intentional radiator is operating, the radio frequency power that is produced by the intentional radiator shall be at least 20 dB below that in the 100 kHz bandwidth within the band that contains the highest level of the desired power, based on either an RF conducted or a radiated measurement, provided the transmitter demonstrates compliance with the peak conducted power limits. In addition, radiated emissions which fall in the restricted bands, as defined in §15.205(a), must also comply with the radiated emission limits specified in 15.209(a) (see Section 15.205(c)).

According to §15.247(e), for digitally modulated systems, the power spectral density conducted from the intentional radiator to the antenna shall not be greater than 8 dBm in any 3 kHz band during any time interval of continuous transmission.

According to §15.247(f), the digital modulation operation of the hybrid system, with the frequency hopping turned off, shall comply with the power density requirements of paragraph (d) of this section.

5. 7 Test Result

A. 6 dB Bandwidth

Product	: WIRELESS ADAPTER	Test Mode	: IEEE 802.11b/g/Draft n 2.4G
Test Item	: 6 dB BW	Temperature	: 25 °C
Test Voltage	: DC 5V (From Host)	Humidity	: 56%RH
Test Result	: PASS		

IEEE 802.11b

Channel	Frequency (MHz)	Bandwidth (MHz)	FCC Limit (kHz)	Result
Low	2412	10.04	>500 kHz	PASS
Mid	2437	10.04		PASS
High	2462	10.36		PASS

IEEE 802.11g

Channel	Frequency (MHz)	Bandwidth (MHz)	FCC Limit (kHz)	Result
Low	2412	16.52	>500 kHz	PASS
Mid	2437	16.52		PASS
High	2462	16.52		PASS

IEEE 802.11n MCS0 20MHz Ant.0

Channel	Frequency (MHz)	Bandwidth (MHz)	FCC Limit (kHz)	Result
Low	2412	17.60	>500 kHz	PASS
Mid	2437	17.56		PASS
High	2462	17.56		PASS

IEEE 802.11n MCS0 40MHz Ant.0

Channel	Frequency (MHz)	Bandwidth (MHz)	FCC Limit (kHz)	Result
Low	2422	35.76	>500 kHz	PASS
Mid	2437	35.24		PASS
High	2452	35.36		PASS

IEEE 802.11n MCS0 20MHz Ant.1

Channel	Frequency (MHz)	Bandwidth (MHz)	FCC Limit (kHz)	Result
Low	2412	17.60	>500 kHz	PASS
Mid	2437	17.60		PASS
High	2462	17.56		PASS

IEEE 802.11n MCS0 40MHz Ant.1

Channel	Frequency (MHz)	Bandwidth (MHz)	FCC Limit (kHz)	Result
Low	2422	35.76	>500 kHz	PASS
Mid	2437	35.88		PASS
High	2452	35.68		PASS

IEEE 802.11b

6dB Bandwidth (CH Low)

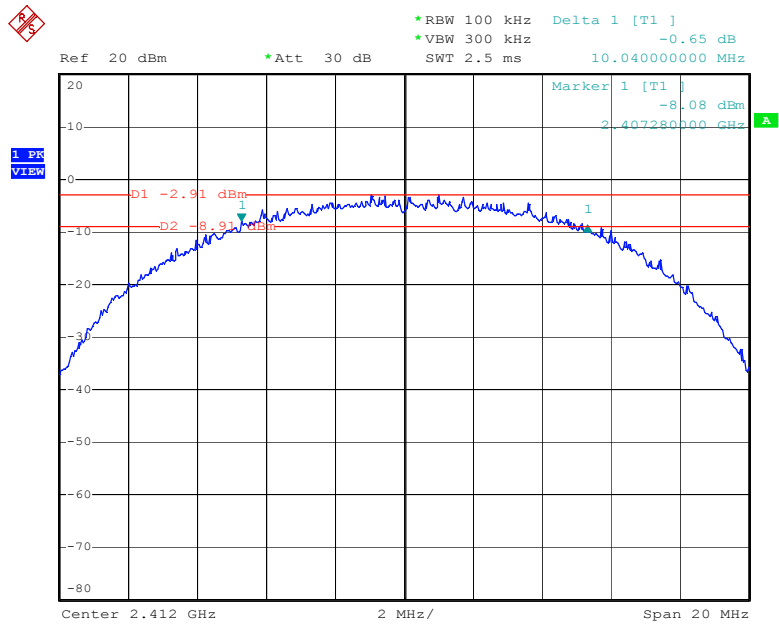

Date: 19.NOV.2015 16:04:58

6dB Bandwidth (CH Mid)

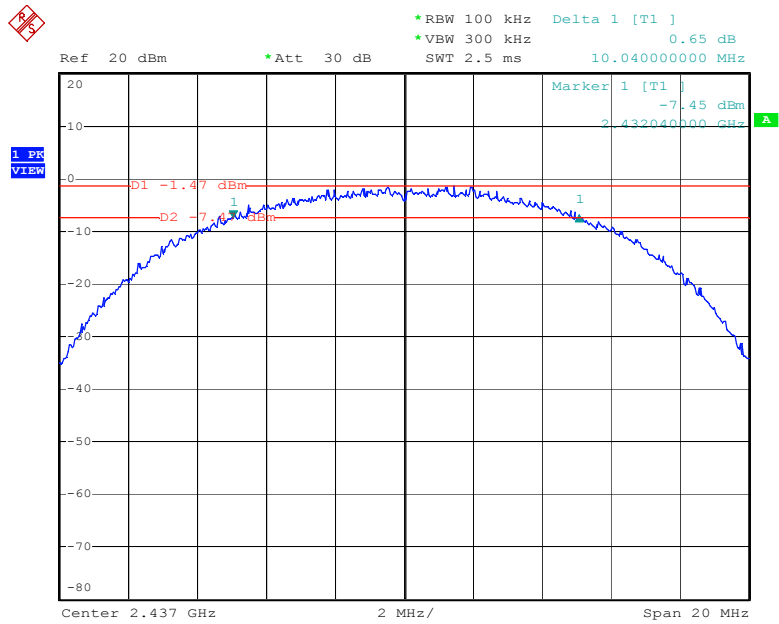

Date: 19.NOV.2015 16:08:17

6dB Bandwidth (CH High)

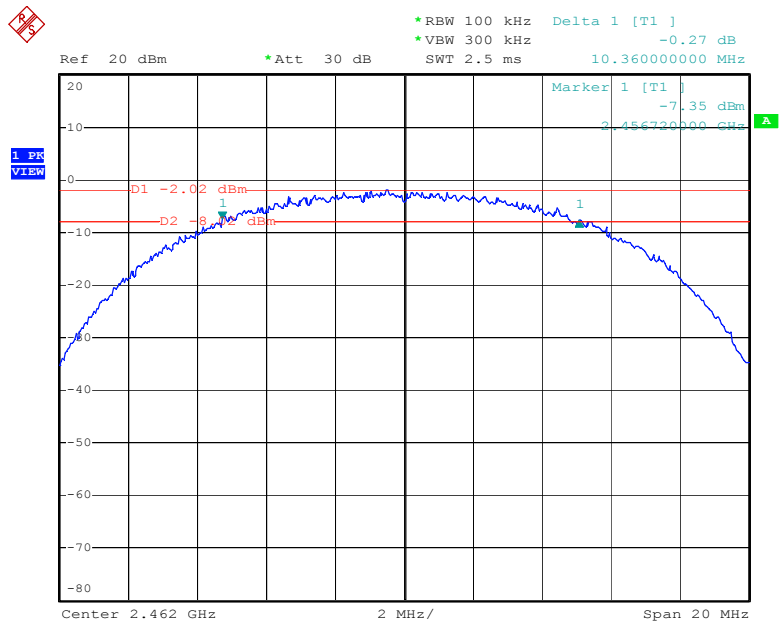

Date: 19.NOV.2015 16:15:11

IEEE 802.11g

6dB Bandwidth (CH Low)

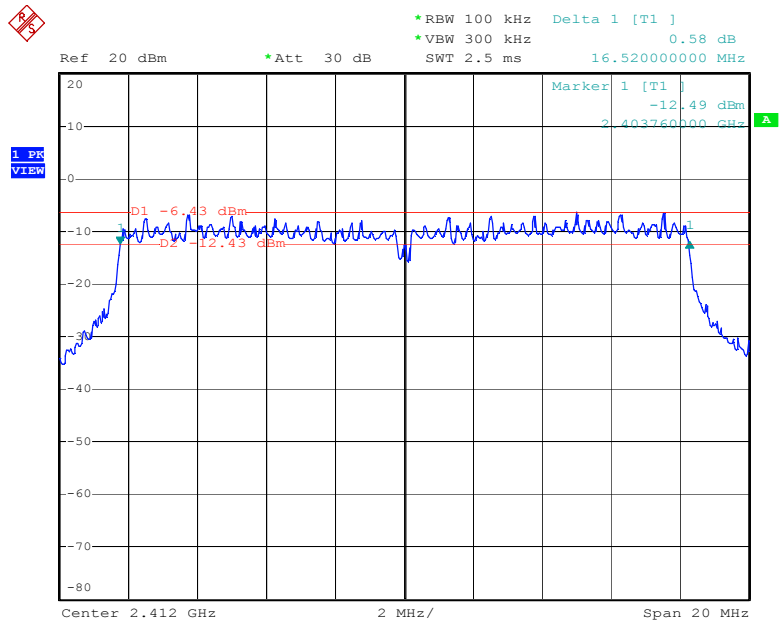

Date: 19.NOV.2015 16:17:57

6dB Bandwidth (CH Mid)

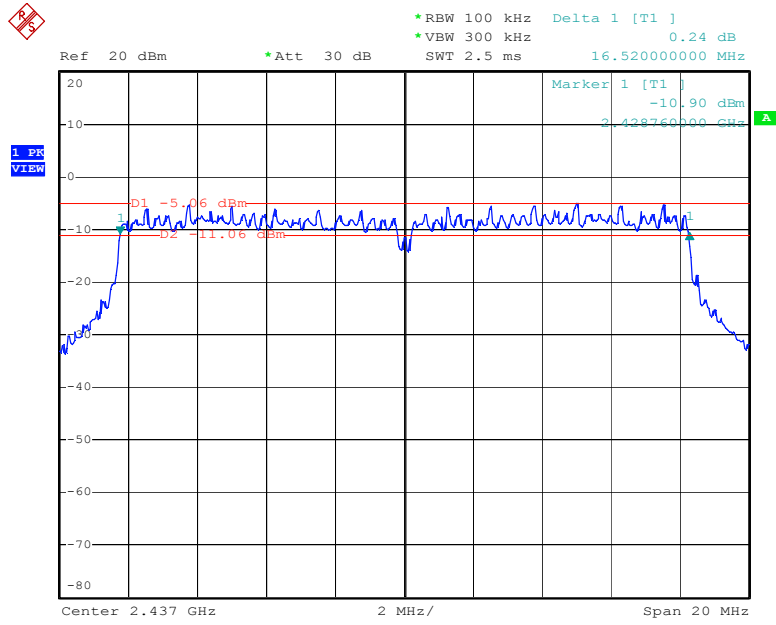

6dB Bandwidth (CH High)

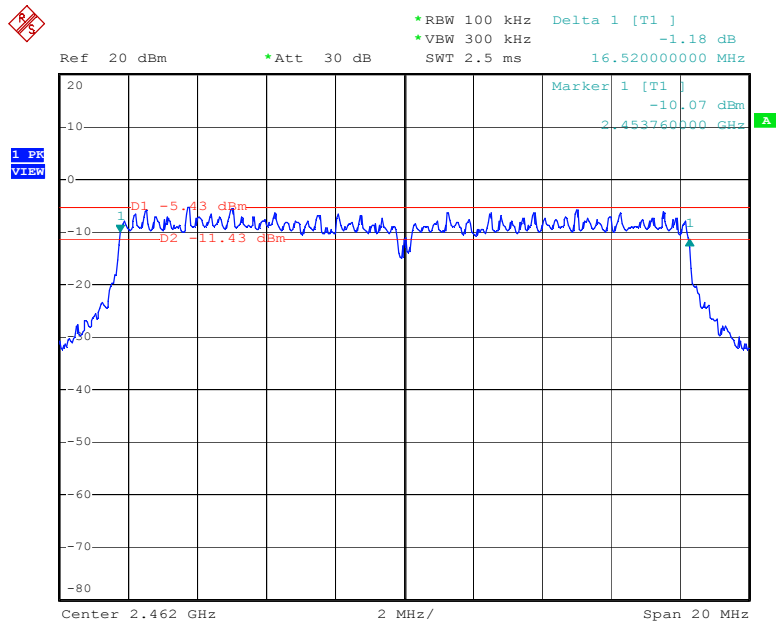

IEEE 802.11n MCS0 20MHz Ant.0

6dB Bandwidth (CH Low)

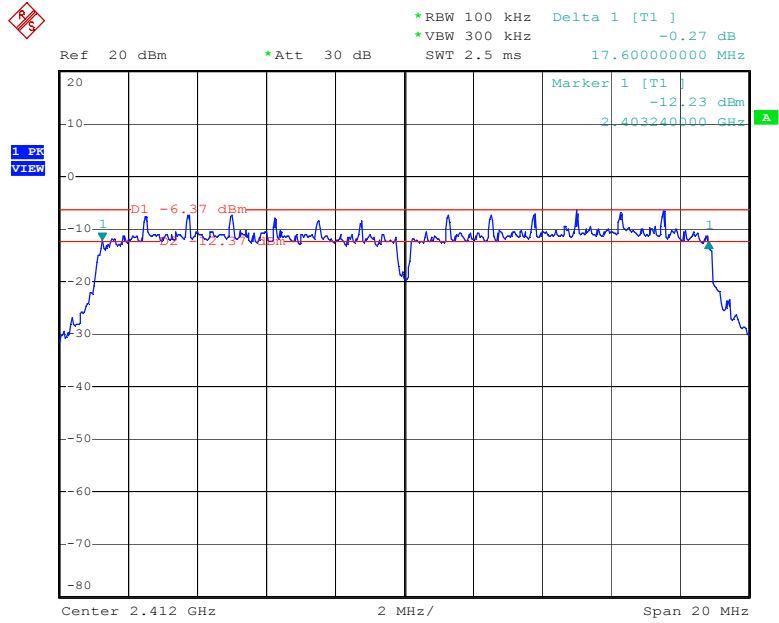

Date: 26.NOV.2015 15:49:10

6dB Bandwidth (CH Mid)

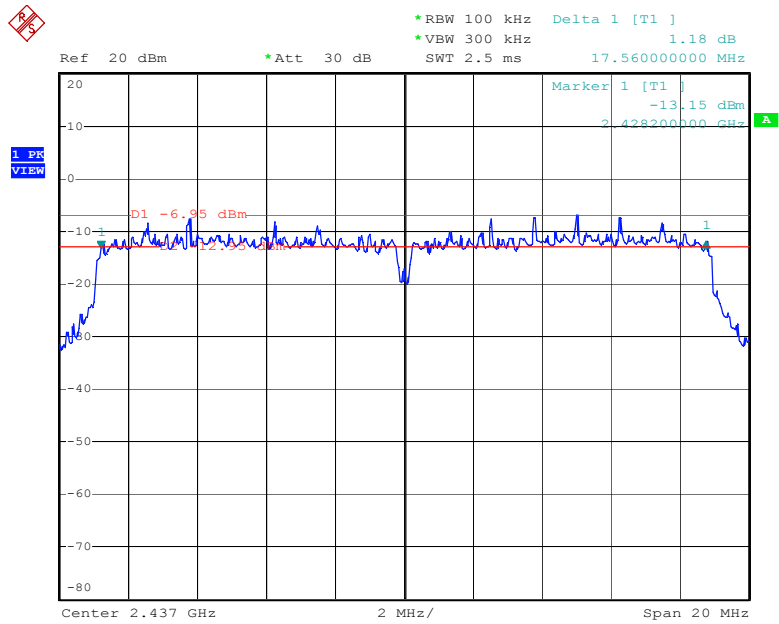

Date: 26.NOV.2015 15:51:53

6dB Bandwidth (CH High)

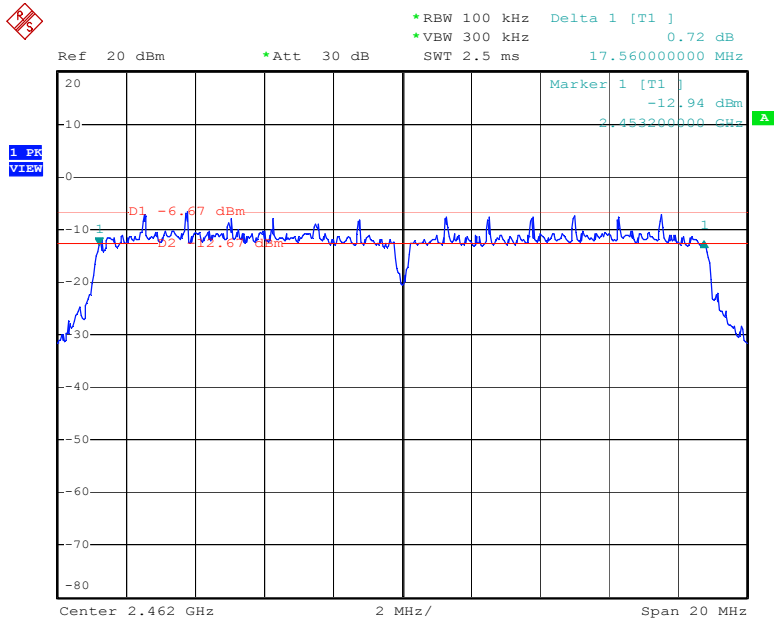

Date: 26.NOV.2015 15:54:04

IEEE 802.11n MCS0 40MHz Ant.0

6dB Bandwidth (CH Low)

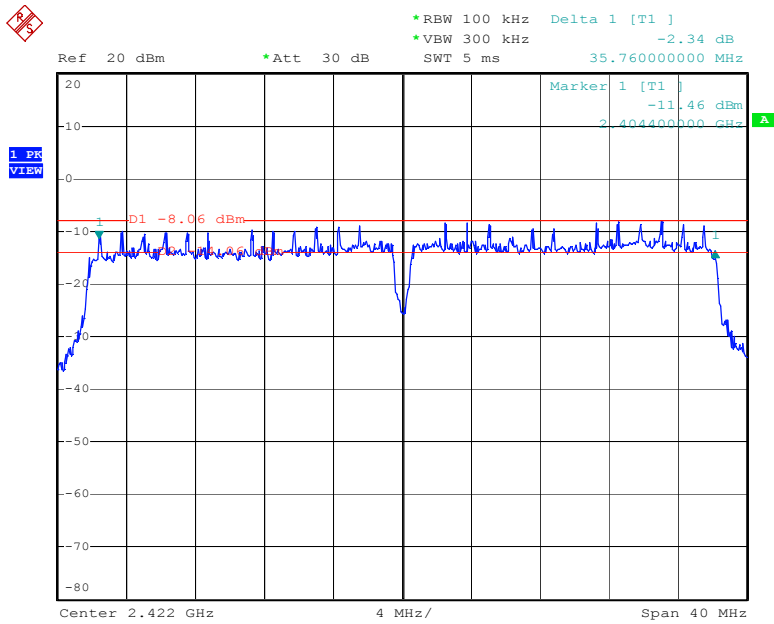

Date: 26.NOV.2015 15:56:24

6dB Bandwidth (CH Mid)

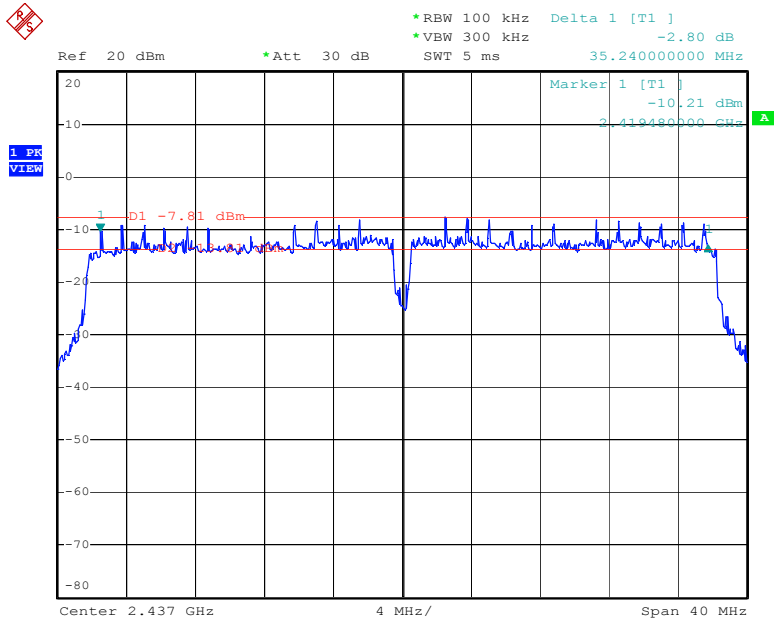

Date: 26.NOV.2015 15:59:13

6dB Bandwidth (CH High)

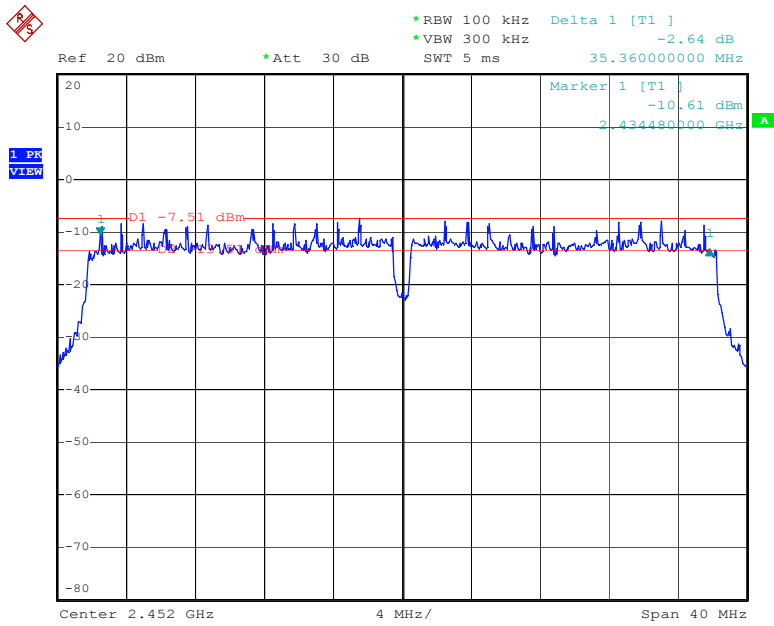

Date: 26.NOV.2015 16:00:50

IEEE 802.11n MCS0 20MHz Ant.1

6dB Bandwidth (CH Low)

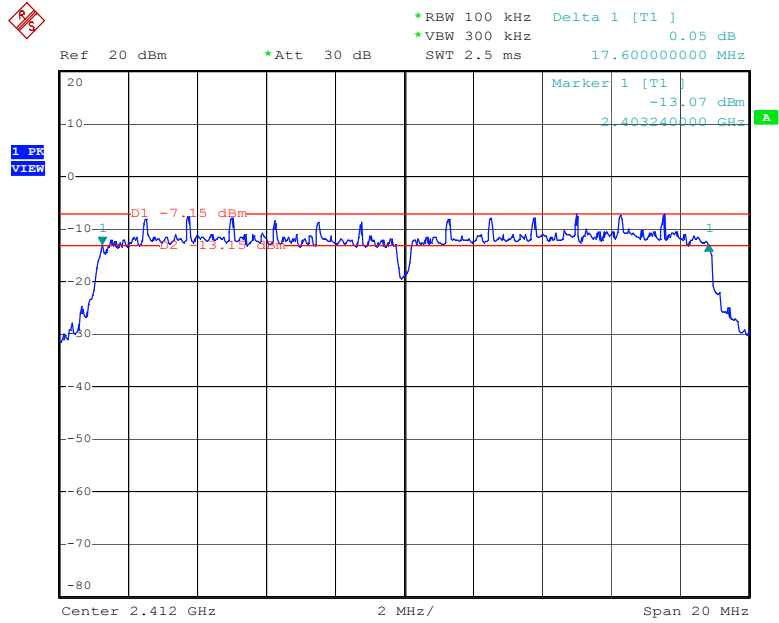

Date: 26.NOV.2015 15:50:53

6dB Bandwidth (CH Mid)

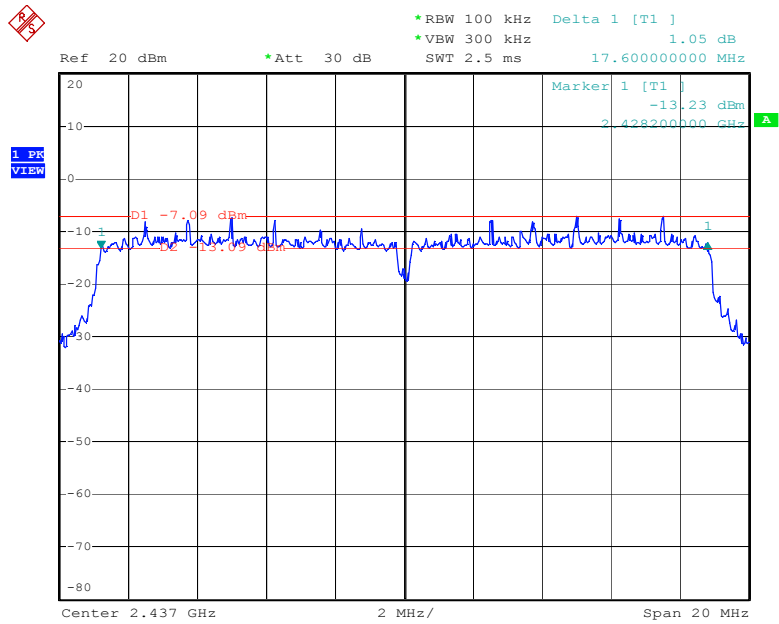

Date: 26.NOV.2015 15:52:55

6dB Bandwidth (CH High)

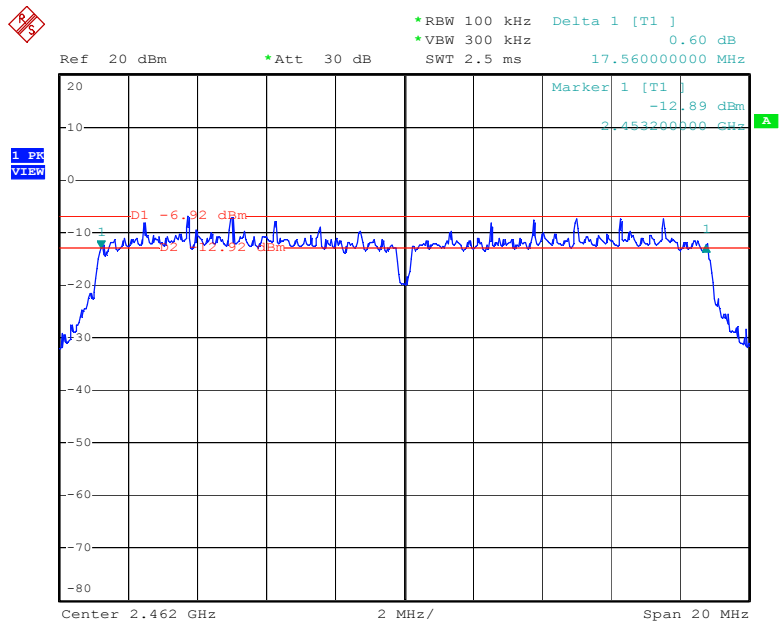

Date: 26.NOV.2015 15:54:58

IEEE 802.11n MCS0 40MHz Ant.1

6dB Bandwidth (CH Low)

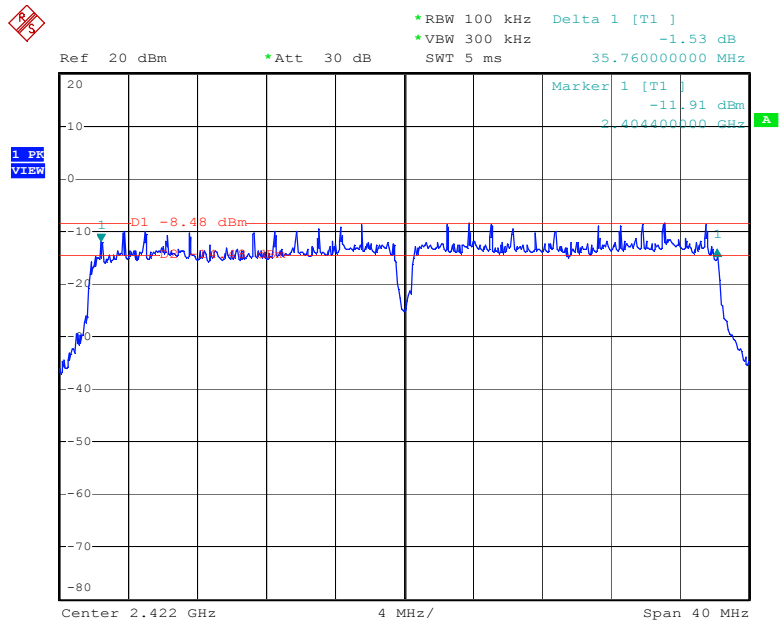

Date: 26.NOV.2015 15:57:27

6dB Bandwidth (CH Mid)

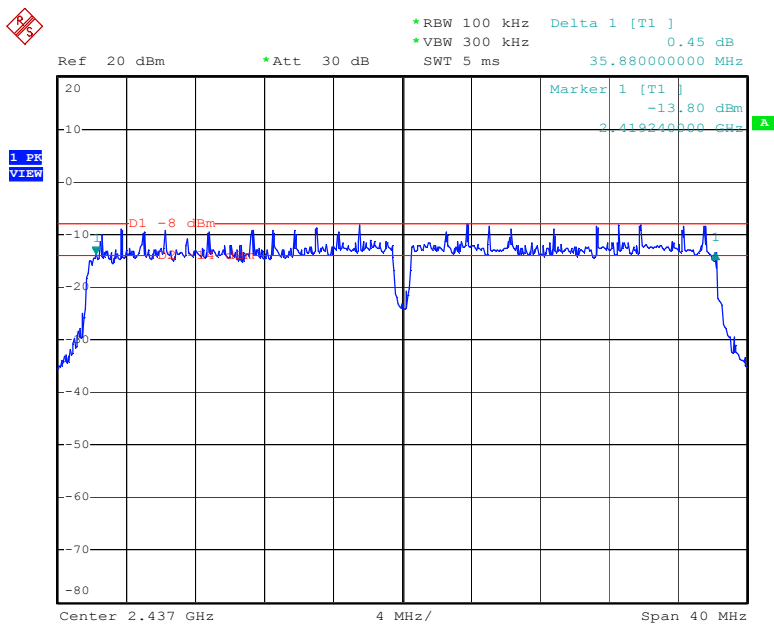

Date: 26.NOV.2015 15:58:21

6dB Bandwidth (CH High)

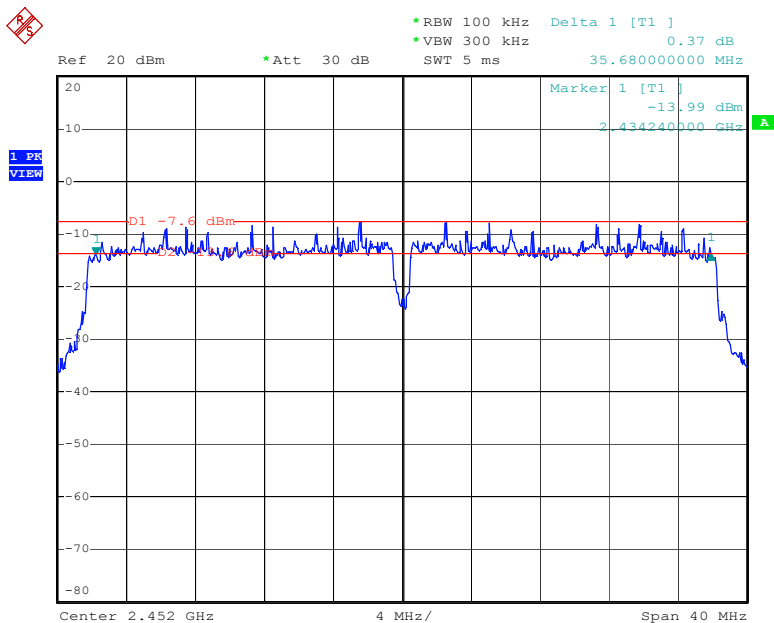

Date: 26.NOV.2015 16:01:55

B. Peak Power

Product	: WIRELESS ADAPTER	Test Mode	: IEEE 802.11b/g/Draft n 2.4G
Test Item	: Peak Power	Temperature	: 25 °C
Test Voltage	: DC 5V (From Host)	Humidity	: 56%RH
Test Result	: PASS		

IEEE 802.11b

Channel	Frequency (MHz)	Output Power (dBm)	FCC Limit (W/dBm)	Result
Low	2412	5.47	1.00/30.00	PASS
Mid	2437	5.89		PASS
High	2462	5.90		PASS

IEEE 802.11g

Channel	Frequency (MHz)	Output Power (dBm)	FCC Limit (W/dBm)	Result
Low	2412	4.58	1.00/30.00	PASS
Mid	2437	4.99		PASS
High	2462	4.44		PASS

IEEE 802.11n MCS8 20MHz Ant.0

Channel	Frequency (MHz)	Output Power (dBm)	FCC Limit (W/dBm)	Result
Low	2412	2.97	1.00/30.00	PASS
Mid	2437	2.77		PASS
High	2462	2.72		PASS

IEEE 802.11n MCS8 40MHz Ant.0

Channel	Frequency (MHz)	Output Power (dBm)	FCC Limit (W/dBm)	Result
Low	2422	1.58	1.00/30.00	PASS
Mid	2437	1.53		PASS
High	2452	1.50		PASS

IEEE 802.11n MCS8 20MHz Ant.1

Channel	Frequency (MHz)	Output Power (dBm)	FCC Limit (W/dBm)	Result
Low	2412	2.88	1.00/30.00	PASS
Mid	2437	2.69		PASS
High	2462	3.01		PASS

IEEE 802.11n MCS8 40MHz Ant.1

Channel	Frequency (MHz)	Output Power (dBm)	FCC Limit (W/dBm)	Result
Low	2422	1.62	1.00/30.00	PASS
Mid	2437	1.65		PASS
High	2452	1.78		PASS

IEEE 802.11n MCS8 20MHz Ant.0+Ant.1

Channel	Frequency (MHz)	Output Power (dBm)	FCC Limit (W/dBm)	Result
Low	2412	5.94	1.00/30.00	PASS
Mid	2437	5.74		PASS
High	2462	5.88		PASS

IEEE 802.11n MCS8 40MHz Ant.0+Ant.1

Channel	Frequency (MHz)	Output Power (dBm)	FCC Limit (W/dBm)	Result
Low	2422	4.61	1.00/30.00	PASS
Mid	2437	4.60		PASS
High	2452	4.65		PASS

C. Band Edges Measurement

Product	: WIRELESS ADAPTER	Test Mode	: IEEE 802.11b/g/Draft n 2.4G
Test Item	: Band Edges Measurement	Temperature	: 25 °C
Test Voltage	: DC 5V (From Host)	Humidity	: 56%RH
Test Result	: PASS		

IEEE 802.11b Channel: Low

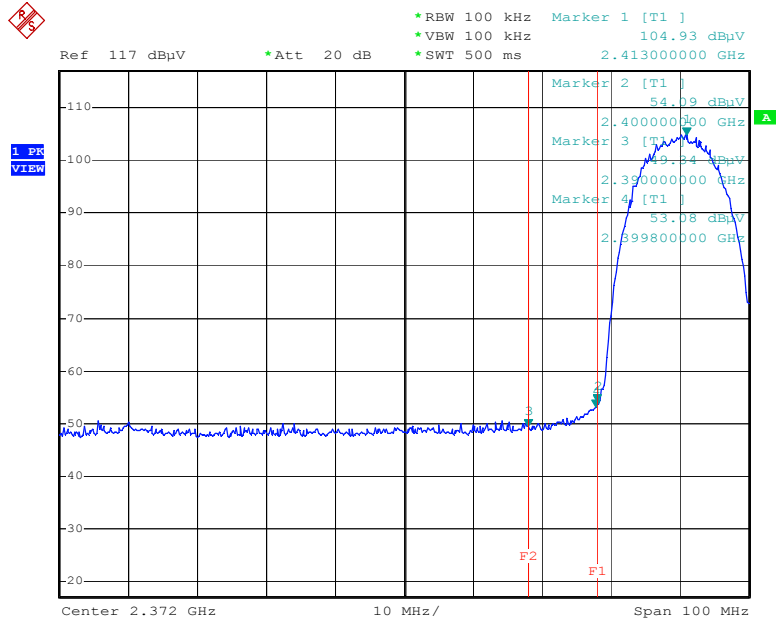

Date: 20.NOV.2015 10:31:45

IEEE 802.11b Channel: High

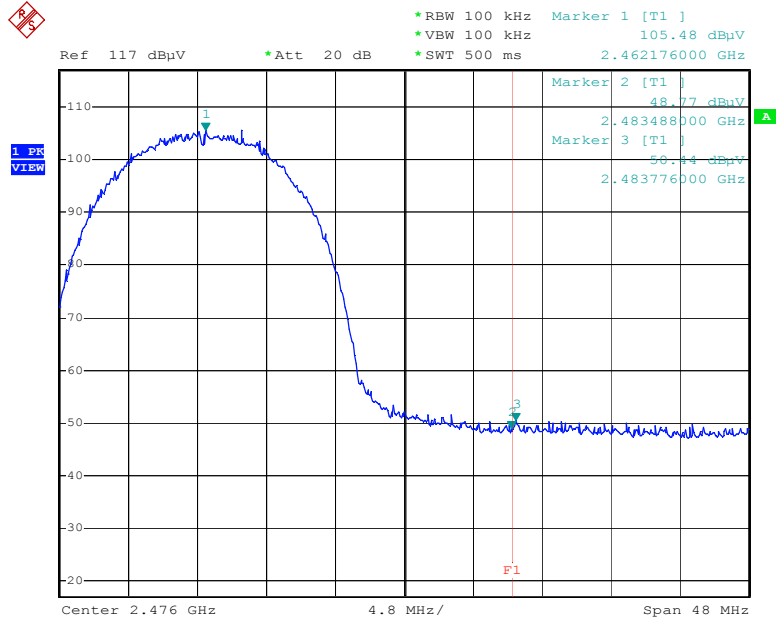

Date: 20.NOV.2015 10:55:27

IEEE 802.11g Channel: Low

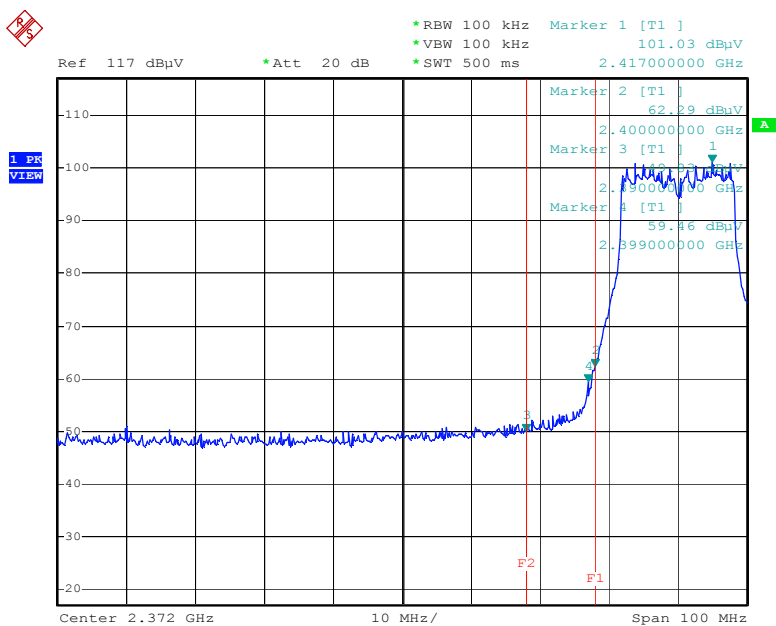

Date: 20.NOV.2015 10:39:57

IEEE 802.11g Channel: High

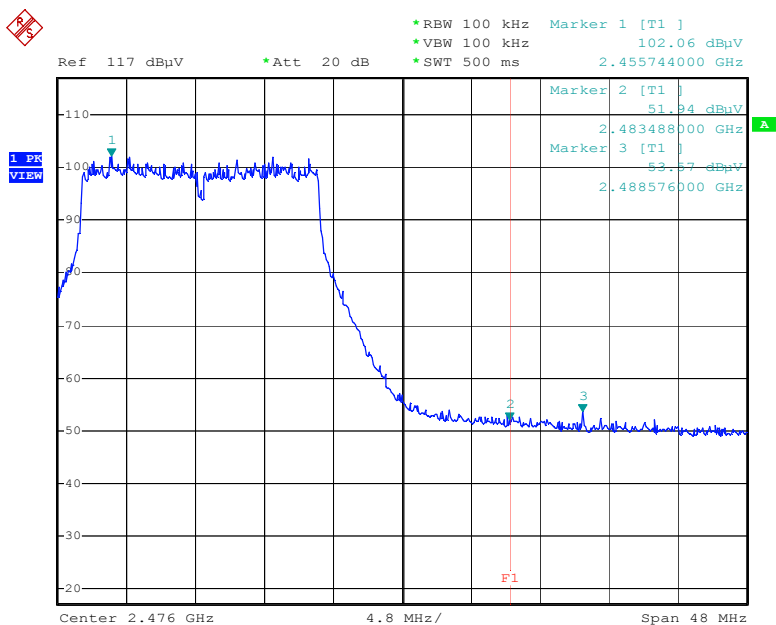

Date: 20.NOV.2015 10:59:41

IEEE 802.11n MCS8 20MHz Ant.0
Channel: Low

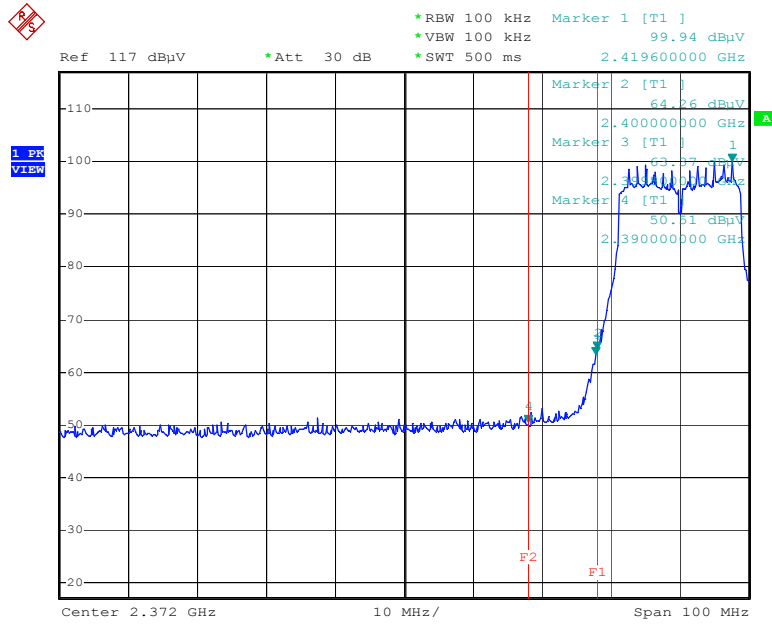

Date: 26.NOV.2015 16:31:27

IEEE 802.11n MCS8 20MHz Ant.0
Channel: High

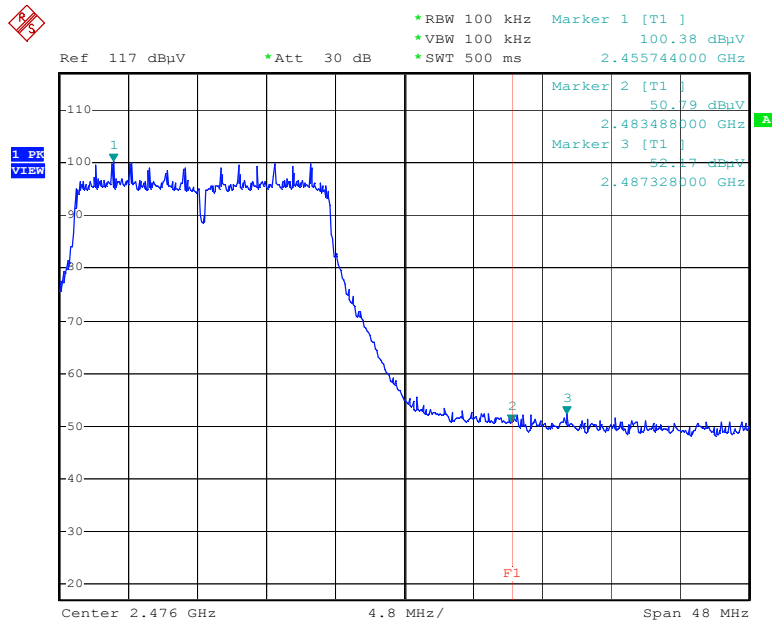

Date: 26.NOV.2015 16:33:34

IEEE 802.11n MCS8 40MHz Ant.0
Channel: Low

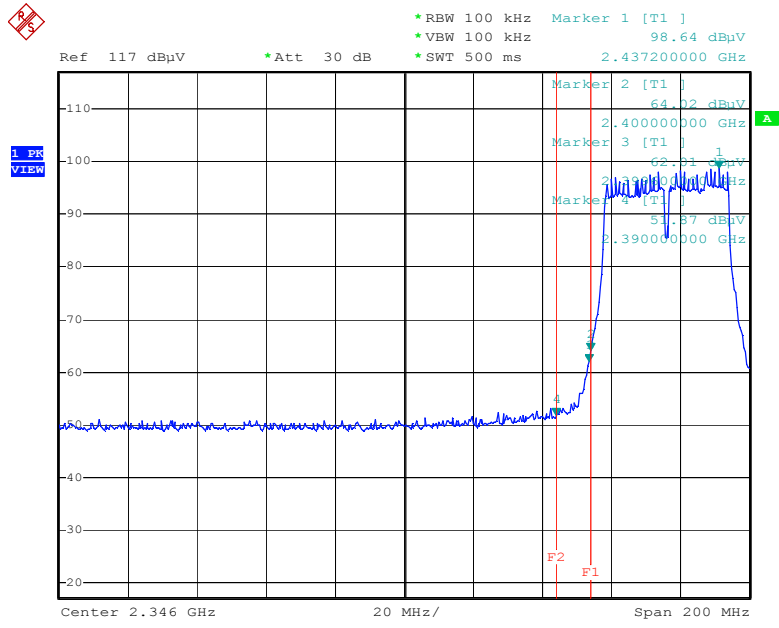

Date: 26.NOV.2015 16:38:17

IEEE 802.11n MCS8 40MHz Ant.0
Channel: High

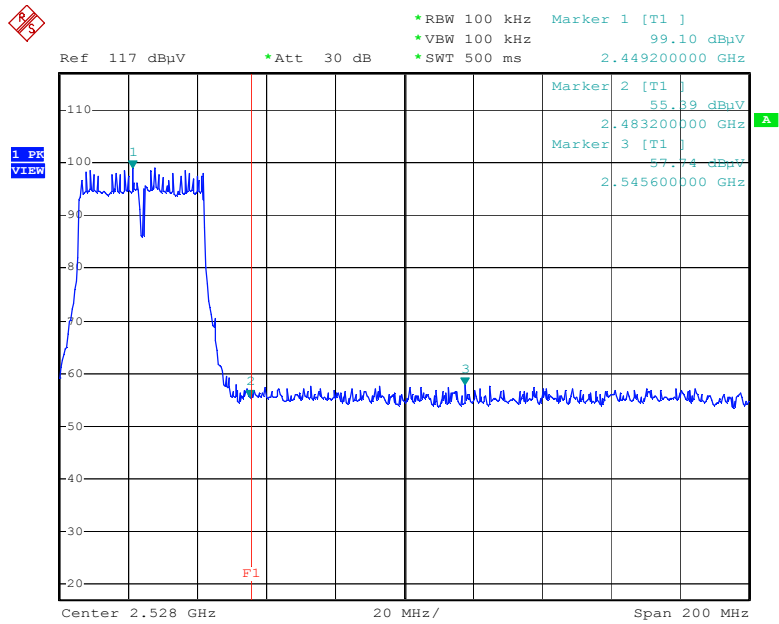

Date: 26.NOV.2015 16:39:57

IEEE 802.11n MCS8 20MHz Ant.1
Channel: Low

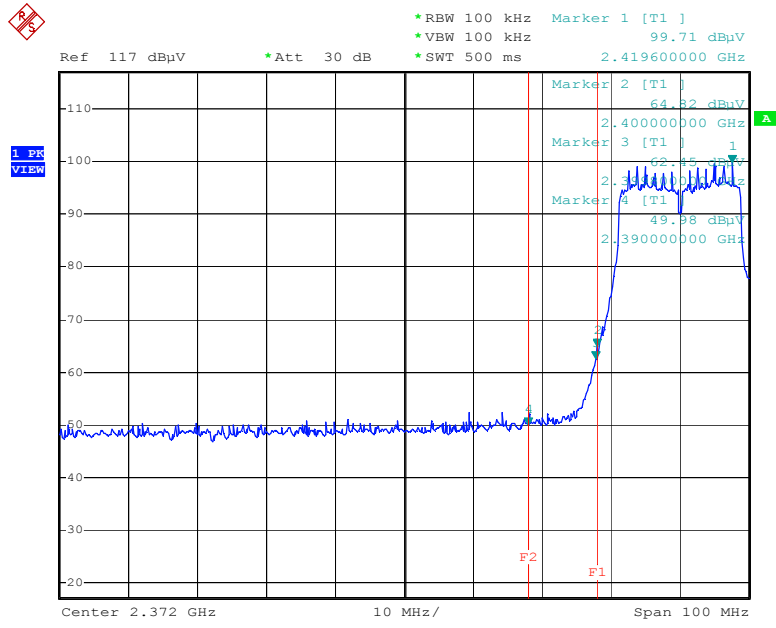

Date: 26.NOV.2015 16:32:16

IEEE 802.11n MCS8 20MHz Ant.1
Channel: High

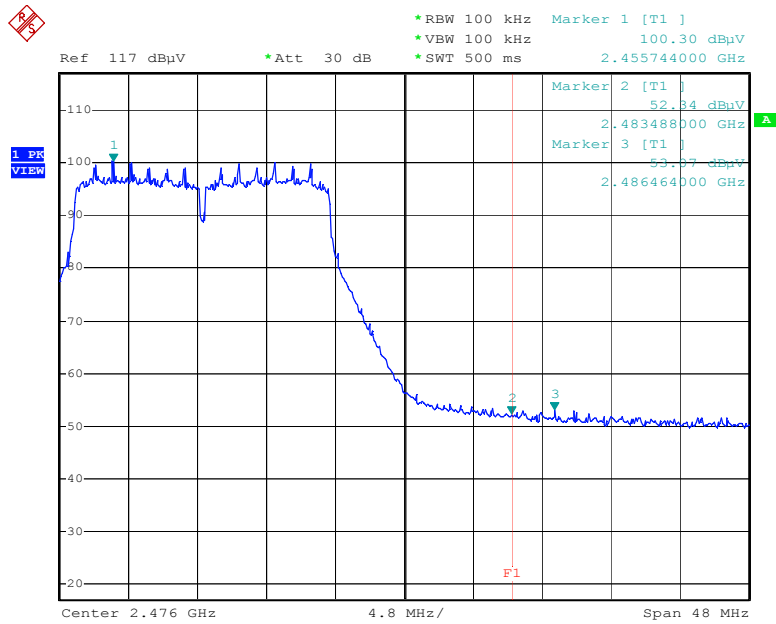

Date: 26.NOV.2015 16:34:45

IEEE 802.11n MCS8 40MHz Ant.1
Channel: Low

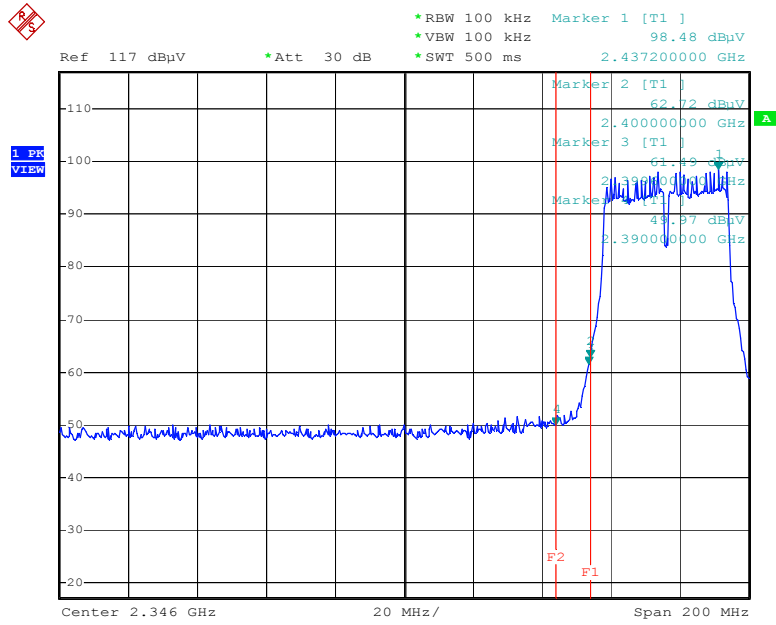

Date: 26.NOV.2015 16:39:00

IEEE 802.11n MCS8 40MHz Ant.1
Channel: High

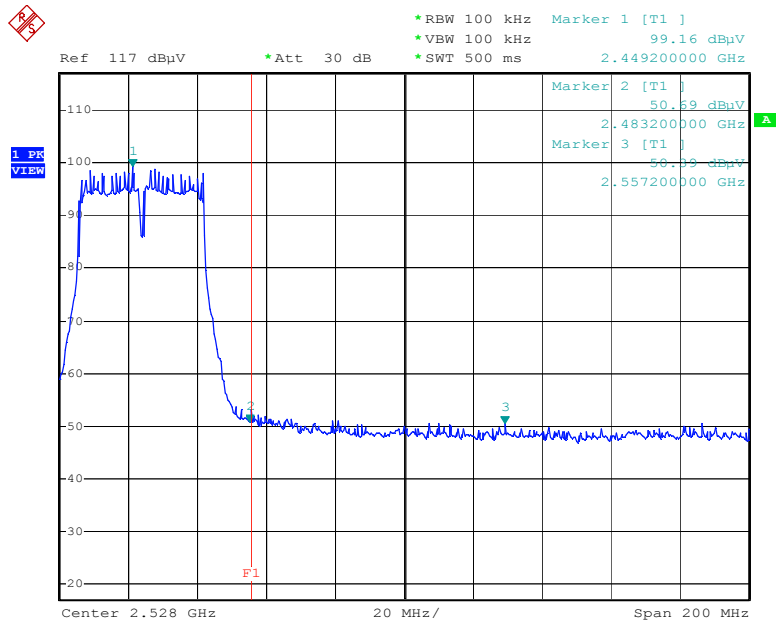

Date: 26.NOV.2015 16:40:30

D. Peak Power Spectral Density

Product	: WIRELESS ADAPTER	Test Mode	: IEEE 802.11b/g/Draft n 2.4G
Test Item	: Peak Power Spectral Density	Temperature	: 25 °C
Test Voltage	: DC 5V (From Host)	Humidity	: 56%RH
Test Result	: PASS		

IEEE 802.11b

Channel	Frequency (MHz)	3kHz PPSD (dBm)	FCC Limit (dBm)	Result
Low	2412	-17.26	8.00	PASS
Mid	2437	-16.17		PASS
High	2462	-16.69		PASS

IEEE 802.11g

Channel	Frequency (MHz)	3kHz PPSD (dBm)	FCC Limit (dBm)	Result
Low	2412	-21.16	8.00	PASS
Mid	2437	-19.77		PASS
High	2462	-19.48		PASS

IEEE 802.11n MCS0 20MHz Ant.0

Channel	Frequency (MHz)	3kHz PPSD (dBm)	FCC Limit (dBm)	Result
Low	2412	-22.07	8.00	PASS
Mid	2437	-22.58		PASS
High	2462	-20.43		PASS

IEEE 802.11n MCS8 40MHz Ant.0

Channel	Frequency (MHz)	3kHz PPSD (dBm)	FCC Limit (dBm)	Result
Low	2422	-21.63	8.00	PASS
Mid	2437	-21.39		PASS
High	2452	-23.52		PASS

IEEE 802.11n MCS0 20MHz Ant.1

Channel	Frequency (MHz)	3kHz PPSD (dBm)	FCC Limit (dBm)	Result
Low	2412	-22.49	8.00	PASS
Mid	2437	-21.98		PASS
High	2462	-21.09		PASS

IEEE 802.11n MCS8 40MHz Ant.1

Channel	Frequency (MHz)	3kHz PPSD (dBm)	FCC Limit (dBm)	Result
Low	2422	-23.20	8.00	PASS
Mid	2437	-23.14		PASS
High	2452	-23.54		PASS

IEEE 802.11n MCS0 20MHz Ant.0+Ant.1

Channel	Frequency (MHz)	3kHz PPSD (dBm)	FCC Limit (dBm)	Result
Low	2412	-19.26	8.00	PASS
Mid	2437	-19.26		PASS
High	2462	-17.74		PASS

IEEE 802.11n MCS8 40MHz Ant.0+Ant.1

Channel	Frequency (MHz)	3kHz PPSD (dBm)	FCC Limit (dBm)	Result
Low	2422	-19.33	8.00	PASS
Mid	2437	-19.17		PASS
High	2452	-20.52		PASS

IEEE 802.11b Channel: Low

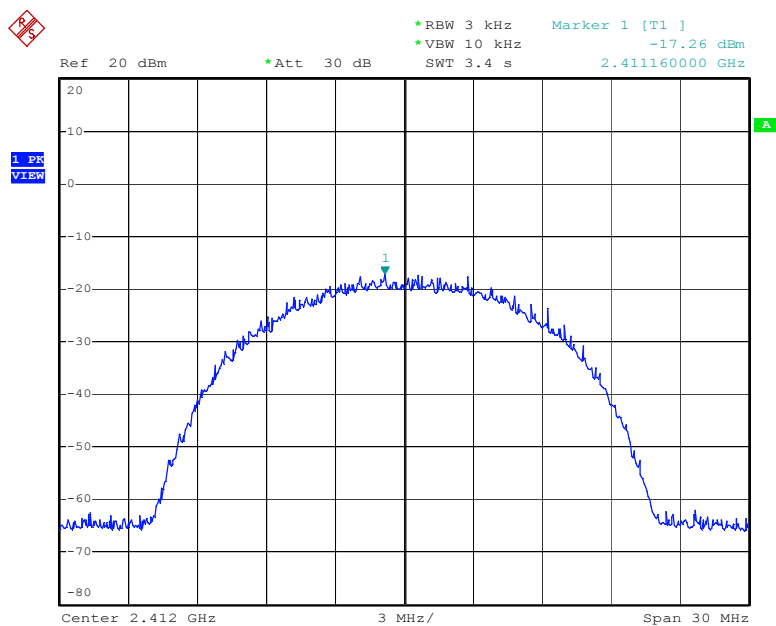

Date: 19.NOV.2015 16:51:39

IEEE 802.11b Channel: Mid

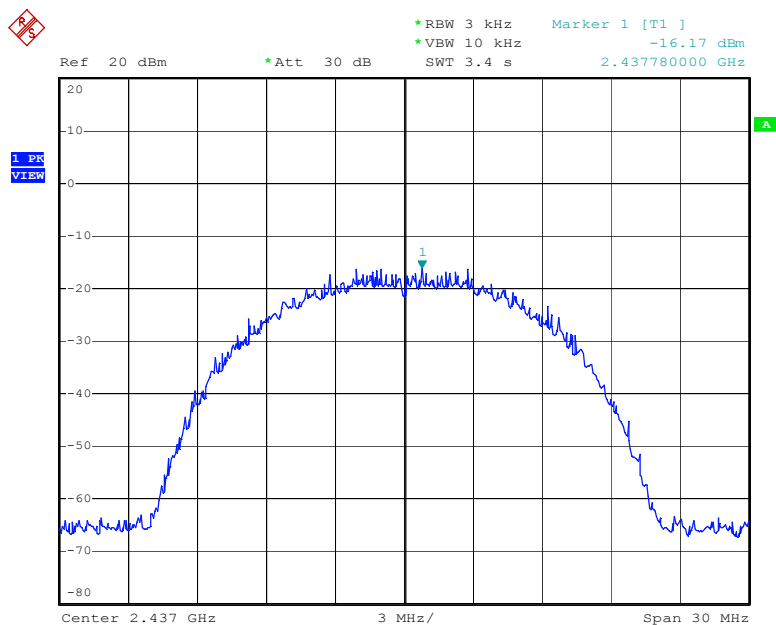

Date: 19.NOV.2015 16:52:34

IEEE 802.11b Channel: High

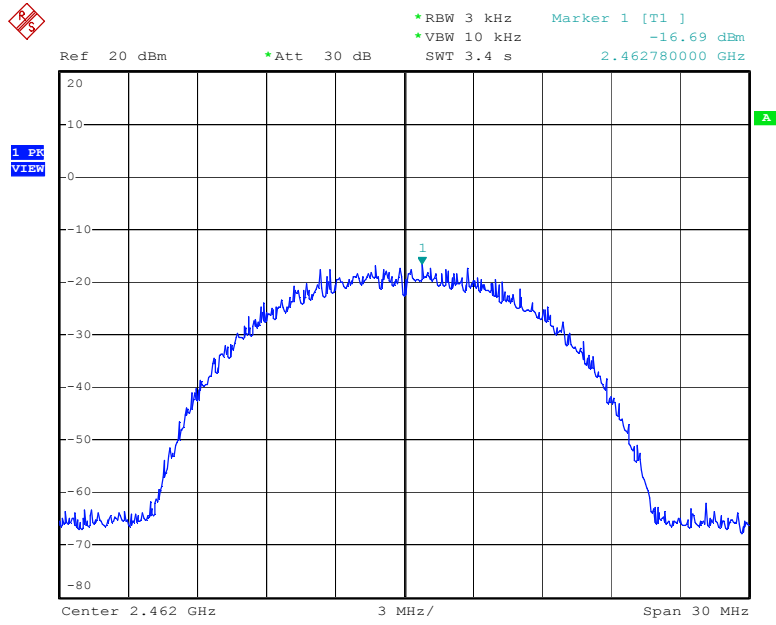

Date: 19.NOV.2015 16:53:22

IEEE 802.11g Channel: Low

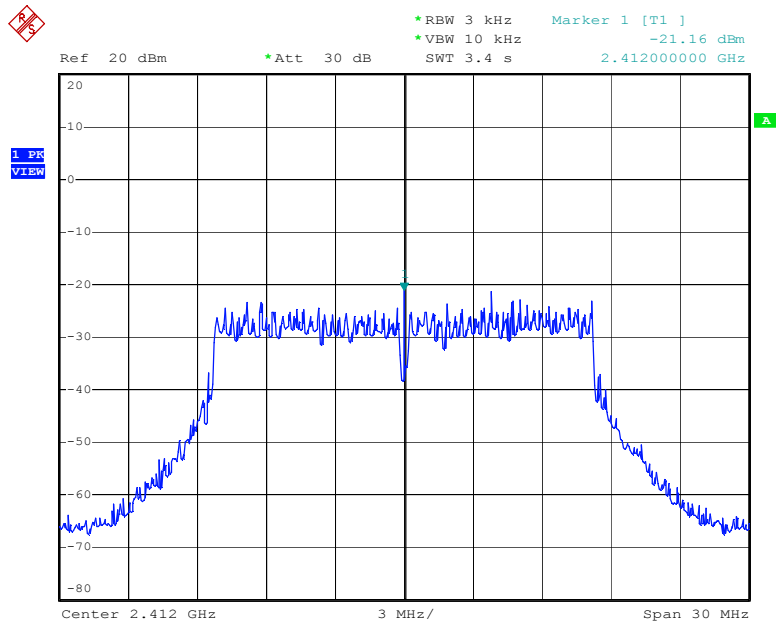

Date: 19.NOV.2015 16:54:19

IEEE 802.11g Channel: Mid

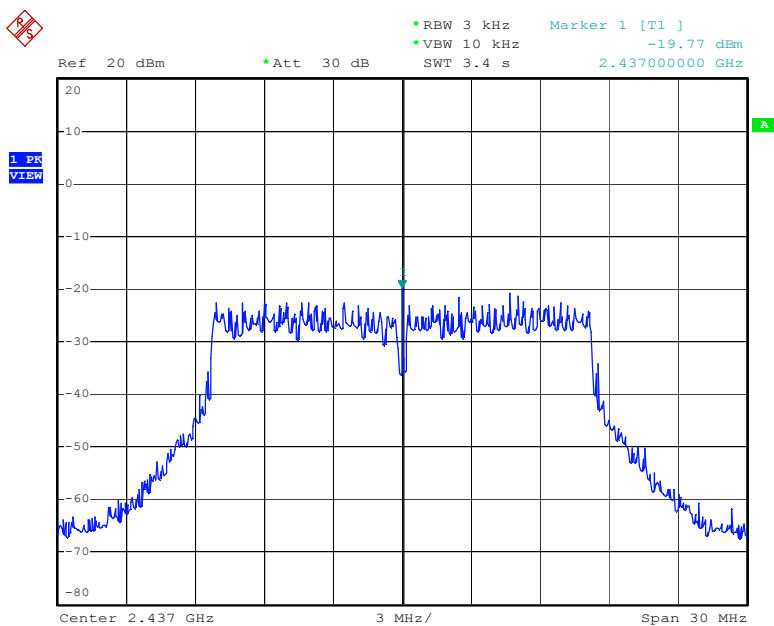

Date: 19.NOV.2015 16:55:04

IEEE 802.11g Channel: High

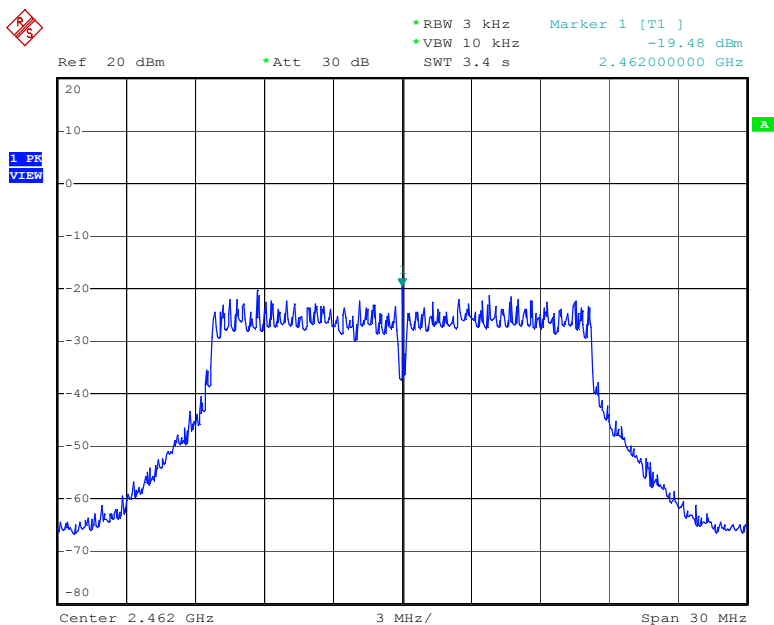

Date: 19.NOV.2015 16:56:07

IEEE 802.11n MCS0 20MHz Ant.0/2412MHZ
(Channel: Low)

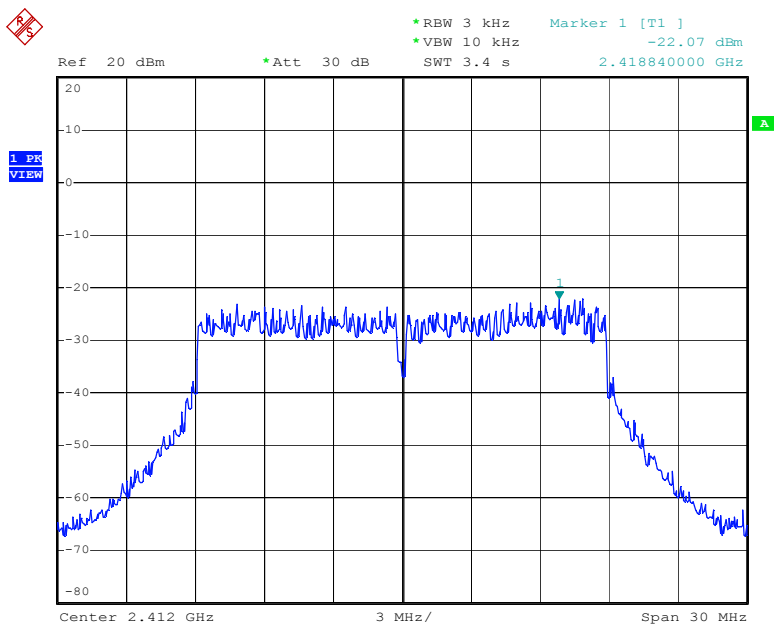

Date: 26.NOV.2015 16:47:23

IEEE 802.11n MCS0 20MHz Ant.0/2437MHZ
(Channel: Mid)

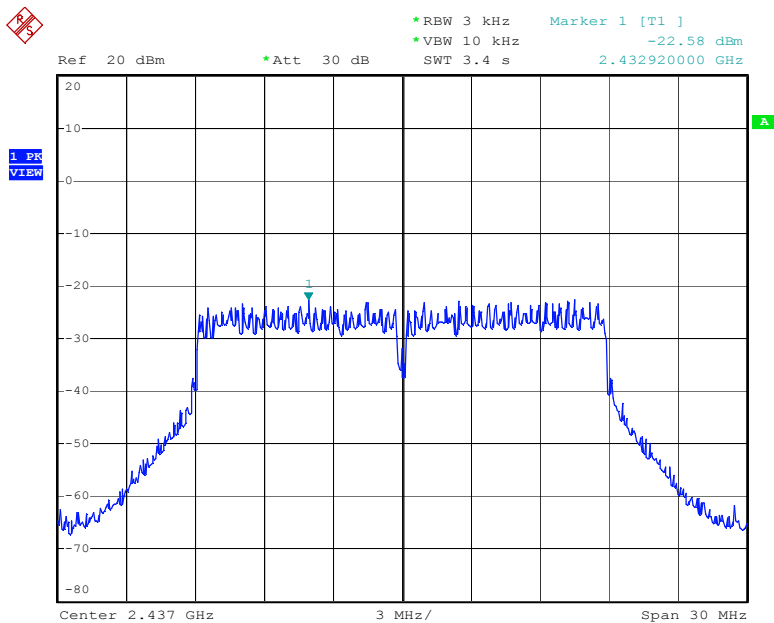

Date: 26.NOV.2015 16:49:13

IEEE 802.11n MCS0 20MHz Ant.0/2462MHZ
(Channel: High)

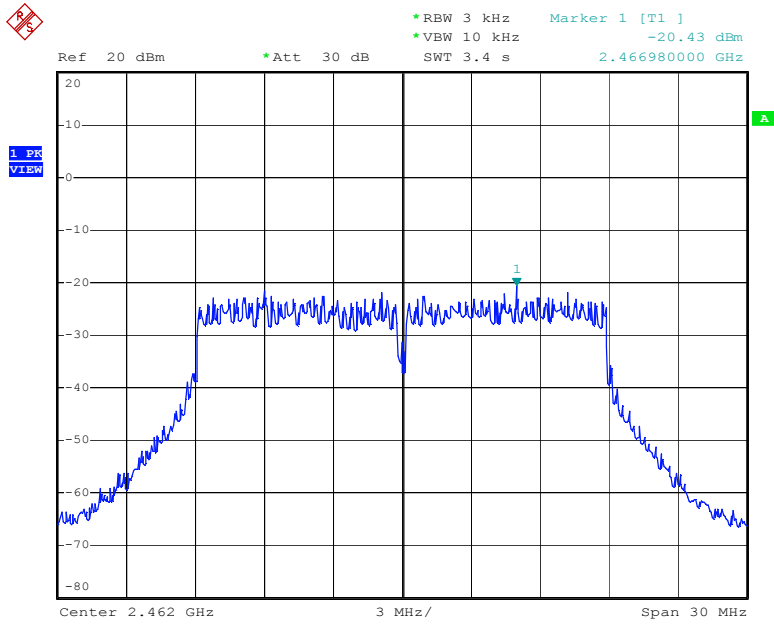

Date: 26.NOV.2015 16:50:04

IEEE 802.11n MCS0 40MHz Ant.0/2422MHZ
(Channel: Low)

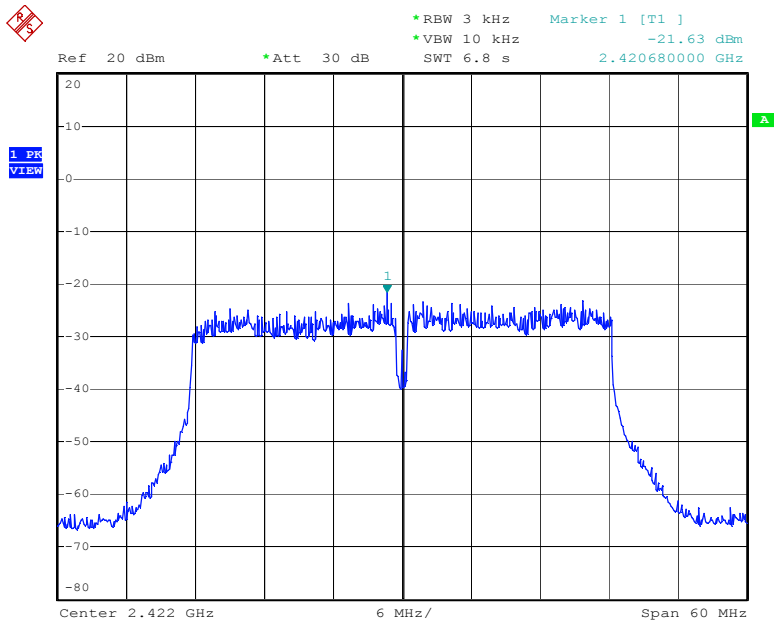

Date: 26.NOV.2015 16:52:31

IEEE 802.11n MCS0 40MHz Ant.0/2437MHZ
(Channel: Mid)

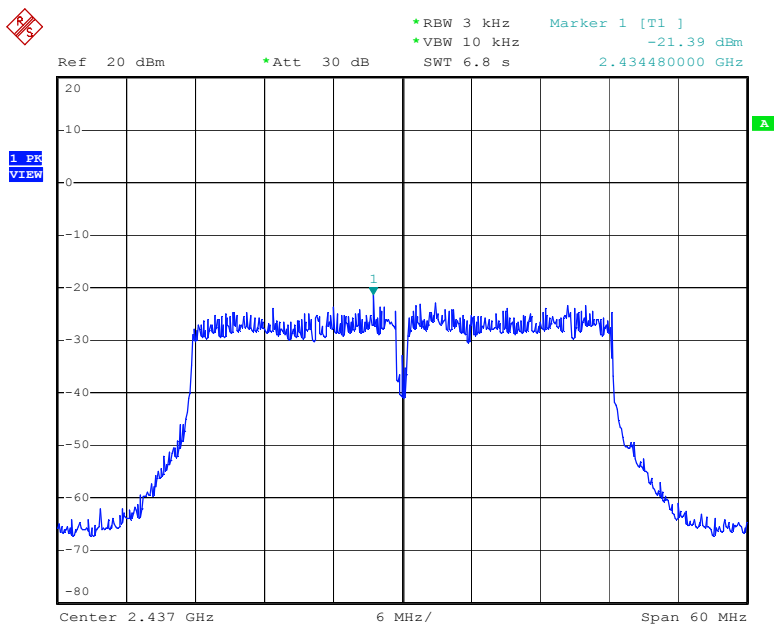

Date: 26.NOV.2015 16:53:24

IEEE 802.11n MCS0 40MHz Ant.0/2452MHZ
(Channel: High)

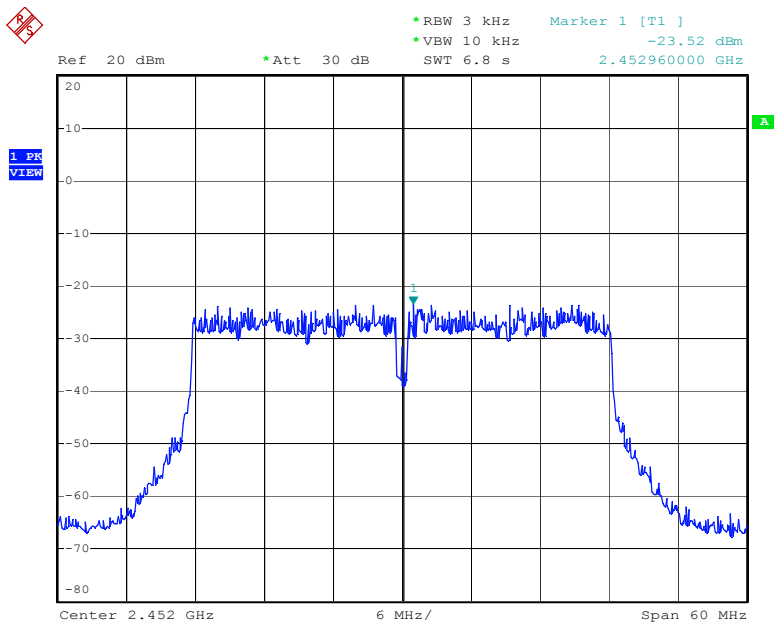

Date: 26.NOV.2015 16:55:33

IEEE 802.11n MCS0 20MHz Ant.1/2412MHZ (Channel: Low)

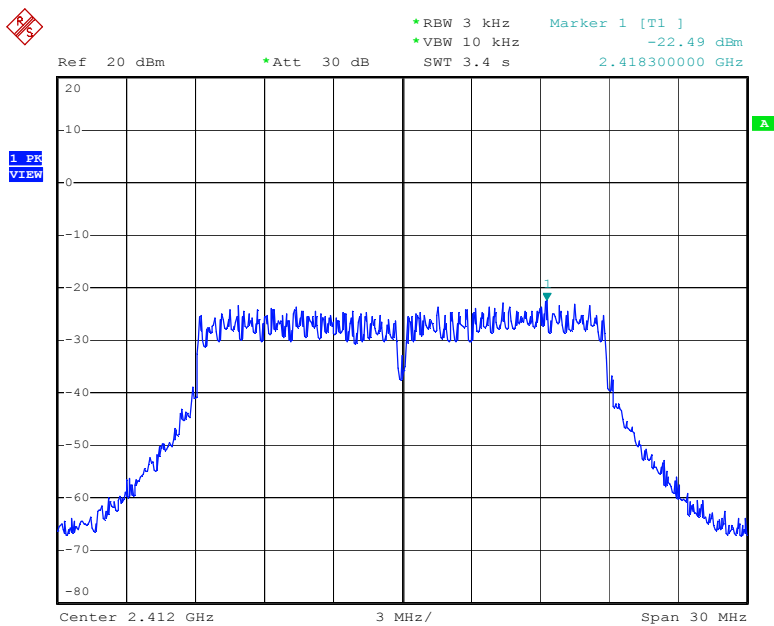

Date: 26.NOV.2015 16:47:54

IEEE 802.11n MCS0 20MHz Ant.1/2437MHZ (Channel: Mid)

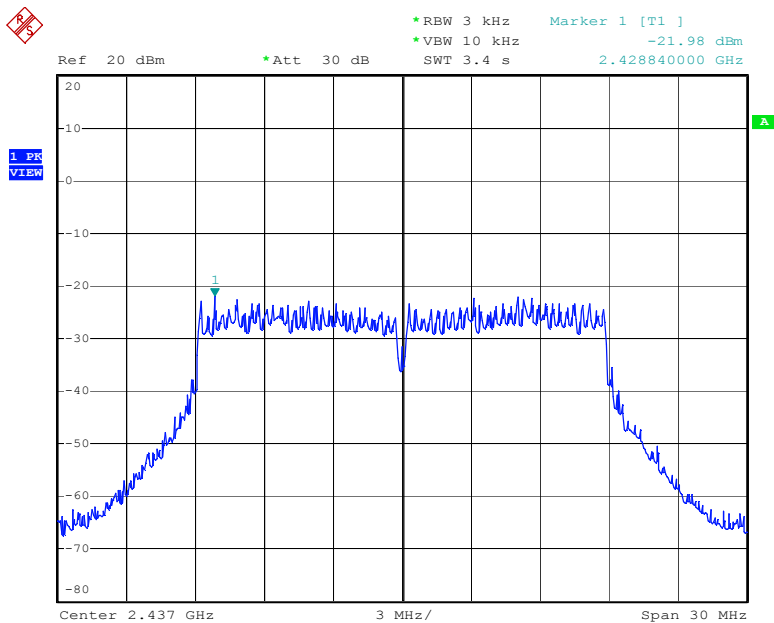

Date: 26.NOV.2015 16:48:38

IEEE 802.11n MCS0 20MHz Ant.1/2462MHZ
(Channel: High)

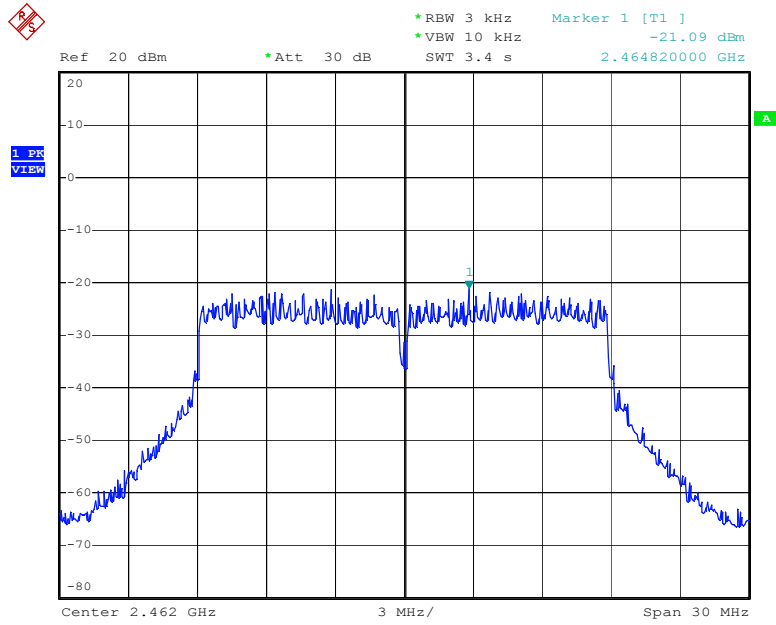

Date: 26.NOV.2015 16:50:36

IEEE 802.11n MCS0 40MHz Ant.1/2422MHZ
(Channel: Low)

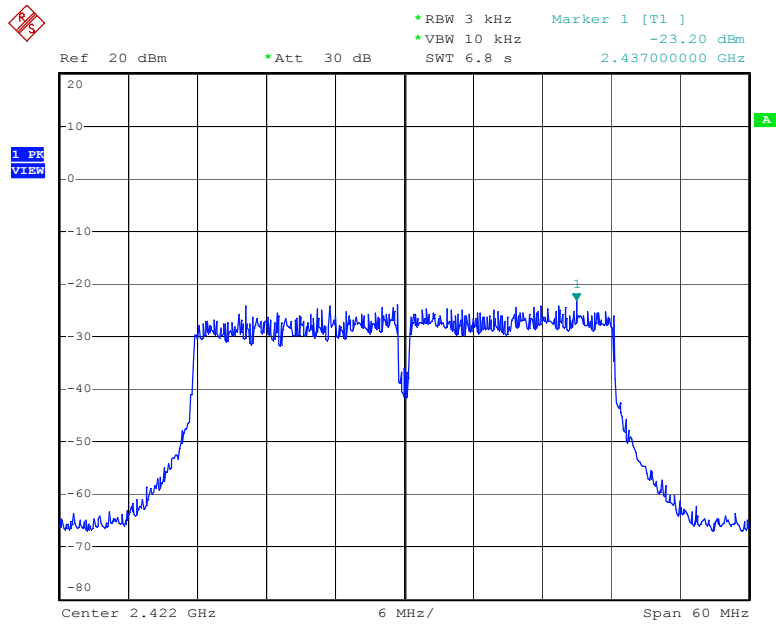

Date: 26.NOV.2015 16:51:33

IEEE 802.11n MCS0 40MHz Ant.1/2437MHZ (Channel: Mid)

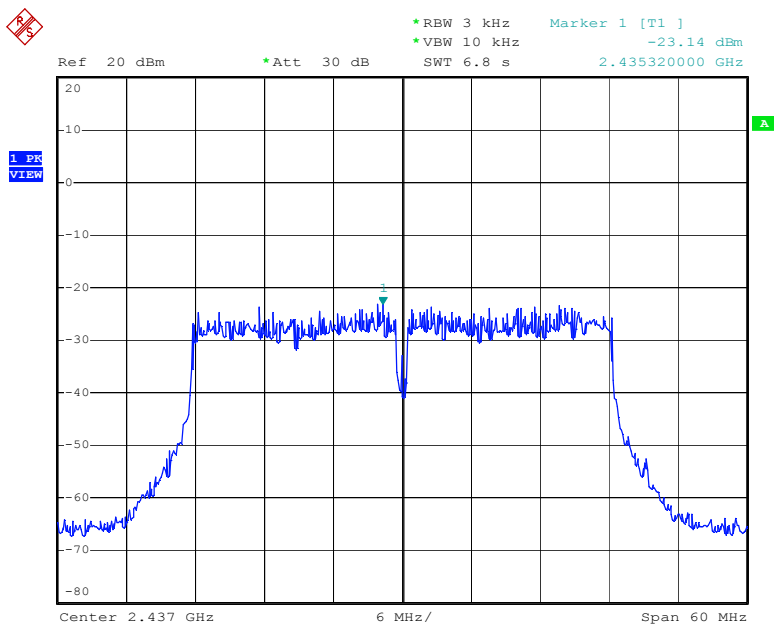

Date: 26.NOV.2015 16:54:07

IEEE 802.11n MCS0 40MHz Ant.1/2452MHZ (Channel: High)

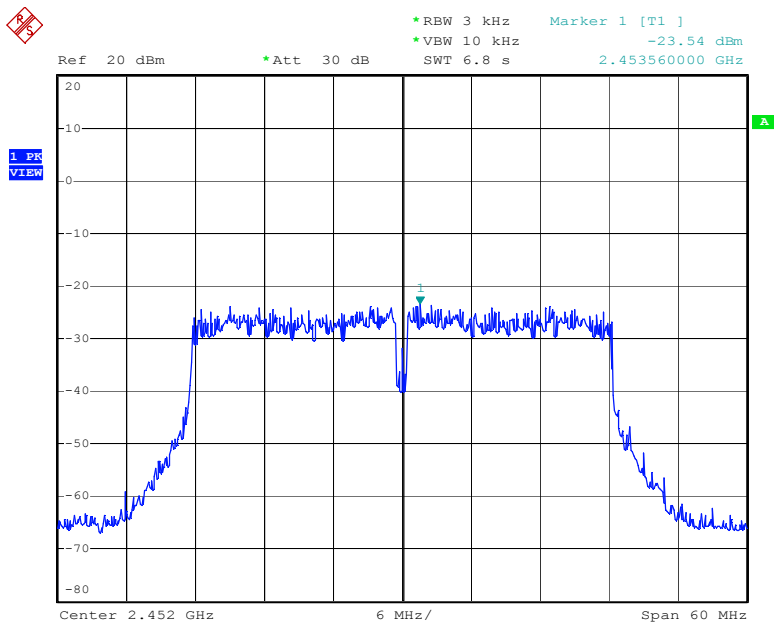

Date: 26.NOV.2015 16:54:51

6. Transmitter Spurious Radiated Emission at 3 Meters

6.1 Test Equipment

Please refer to Section 10 this report.

6.2 Test Procedure

1. The EUT was tested according to ANSI C63.10:2013.
2. The EUT, peripherals were put on the turntable which table size is 1m x 1.5 m, table high 0.8 m, and which is 1.5 m high for above 1 GHz. All set up is according to ANSI C63.10:2013 .
3. The frequency spectrum from 9 kHz to 25 GHz was investigated. All readings from 9 kHz to 150 kHz are quasi-peak values with a resolution bandwidth of 200 Hz. All readings from 150 kHz to 30 MHz are quasi-peak values with a resolution bandwidth of 9 KHz. All readings from 30 MHz to 1 GHz are quasi-peak values with a resolution bandwidth of 120 KHz. Measurements were made at 3 meters.
4. The emissions from the EUT were measured continuously at every azimuth by rotating the turntable. The Receiving antenna high is varied from 1 m to 4 m high to find the maximum emission for each frequency. Emissions below 30MHz were measured with a loop antenna while emission above 30MHz were measured using a broadband E-field antenna.
5. Maximizing procedure was performed on the six (6) highest emissions to ensure EUT compliance is with all installation combinations. All data was recorded in the peak detection mode. Quasi-peak readings was performed only when an emission was found to be marginal (within -4 dB of specification limit), and are distinguished with a "QP" in the data table.
6. Each emission was to be maximized by changing the polarization of receiving antenna both horizontal and vertical. In order to find out the max. emission, the relative positions of this transmitter(EUT) was rotated through three orthogonal axes according to the requirements in Section 8 and 13 of ANSI C63.10:2013

6.3 Test Setup

For Frequencies below 30 MHz

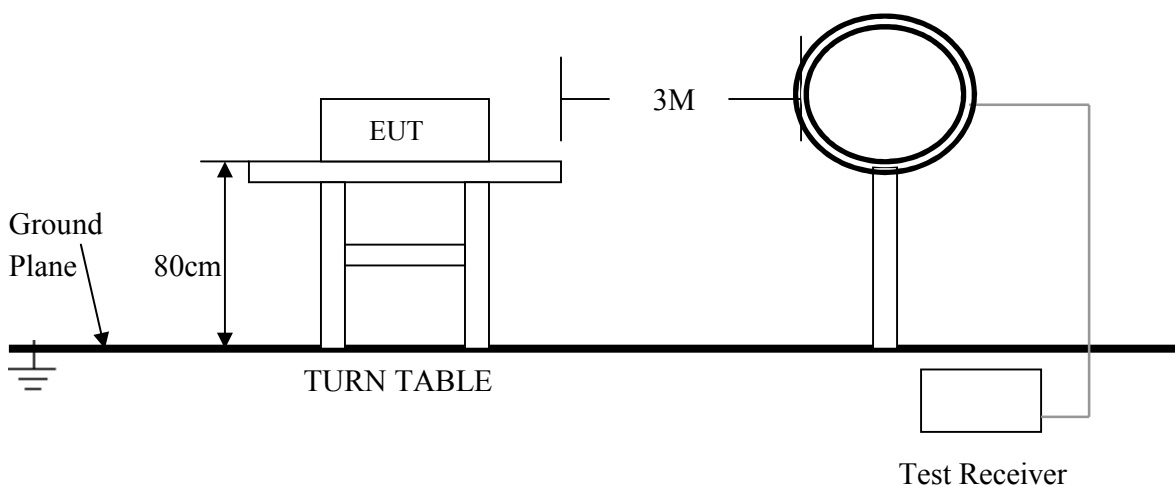

For the actual test configuration , please refer to the related items – Photos of Testing

For Frequencies above 30 MHz

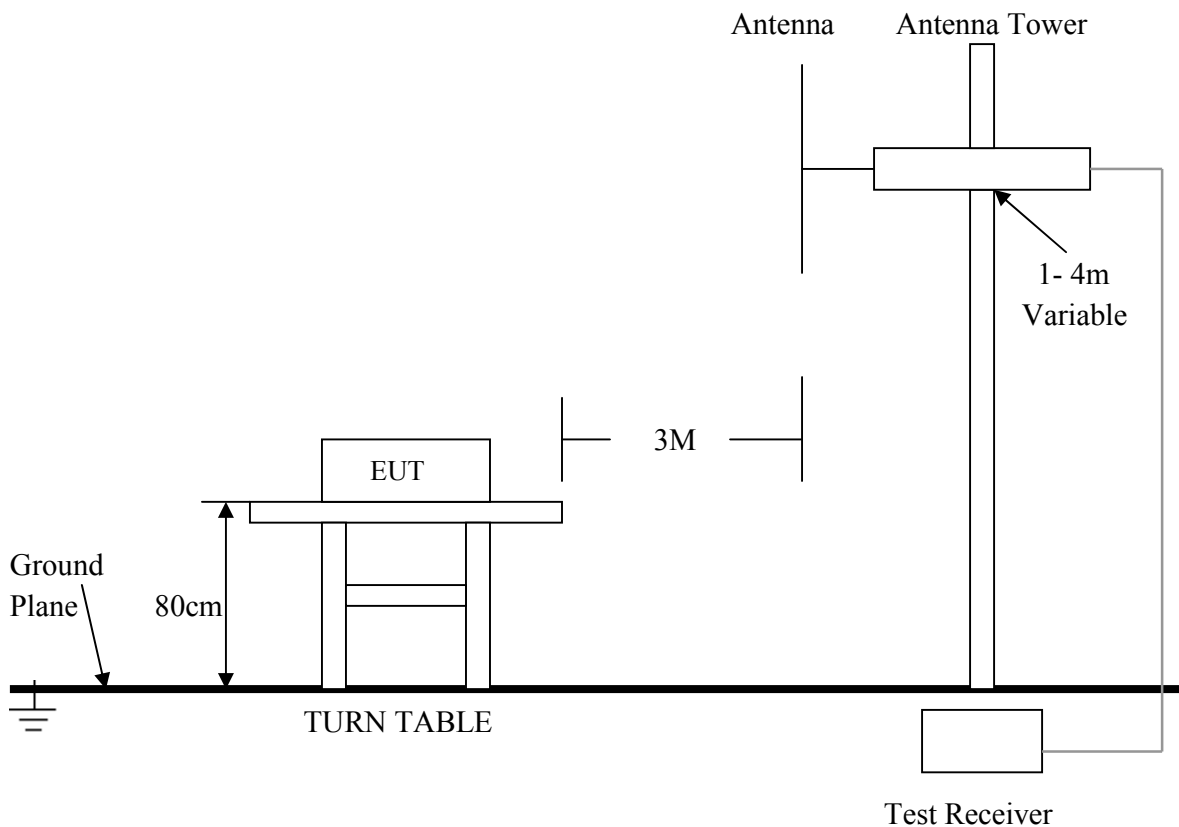

For the actual test configuration , please refer to the related items – Photos of Testing

6. 4 Configuration of the EUT

Same as section 4.4 of this report

6. 5 EUT Operating Condition

Same as section 4.5 of this report.

6.6 Limit

In any 100 KHz bandwidth outside the operating frequency band, the radio frequency power that is produced by modulation products of the spreading sequence, the information sequence and the carrier frequency shall be either at least 20 dB below that in any 100 KHz bandwidth within the band that contains the highest level of the desired power or shall not exceed the general levels specified in section 15.209(a), which lesser attenuation.

All other emissions inside restricted bands specified in section 15.205(a) shall not exceed the general radiated emission limits specified in section 15.209(a)

Note:

Applies to harmonics/spurious emissions that fall in the restricted bands listed in section 15.205. The maximum permitted average field strength is listed in section 15.209.

47 CFR § 15.237(c): The emission limits as specified above are based on measurement instrument employing an average detector. The provisions in section 15.35 for limiting peak emissions apply.

FCC CFR 47, Part 15, Subpart C, Para. 15.205(a) – Restricted Frequency Bands

MHz	MHz	MHz	GHz
0.090–0.110	16.42–16.423	399.9–410	4.5–5.15
1.495–0.505	16.69475–16.69525	608–614	5.35–5.46
2.1735–2.1905	16.80425–16.80475	960–1240	7.25–7.75
4.125–4.128	25.5–25.67	1300–1427	8.025–8.5
4.17725–4.17775	37.5–38.25	1435–1626.5	9.0–9.2
4.20725–4.20775	73–74.6	1645.5–1646.5	9.3–9.5
6.215–6.218	74.8–75.2	1660–1710	10.6–12.7
6.26775–6.26825	108–121.94	1718.8–1722.2	13.25–13.4
6.31175–6.31225	123–138	2200–2300	14.47–14.5
8.291–8.294	149.9–150.05	2310–2390	15.35–16.2
8.362–8.366	156.52475–156.52525	2483.5–2500	17.7–21.4
8.37625–8.38675	156.7–156.9	2655–2900	22.01–23.12
8.41425–8.41475	162.0125–167.17	3260–3267	23.6–24.0
12.29–12.293	167.72–173.2	3332–3339	31.2–31.8
12.51975–12.52025	240–285	3345.8–3358	36.43–36.5
12.57675–12.57725	322–335.4	3600–4400	(2)
13.36–13.41.			

¹ Until February 1, 1999, this restricted band shall be 0.490–0.510 MHz.

² Above 38.6

FCC 47 CFR, Part 15.209(a) – Field Strength Limits within Restricted Frequency Bands

Frequency (MHz)	Field strength (microvolts/meter)	Measurement distance (meters)
0.009–0.490	2400/F(kHz)	300
0.490–1.705	24000/F(kHz)	30
1.705–30.0	30	30
30–88	100**	3
88–216	150**	3
216–960	200**	3
Above 960	500	3

6.7 Test Result

Product	: WIRELESS ADAPTER	Test Mode	: IEEE 802.11b/g/Draft n 2.4G
Test Item	: Spurious Radiated Emissions	Temperature	: 25 °C
Test Voltage	: DC 5V (From Host)	Humidity	: 56%RH
Test Result	: PASS		

802.11b CH Low

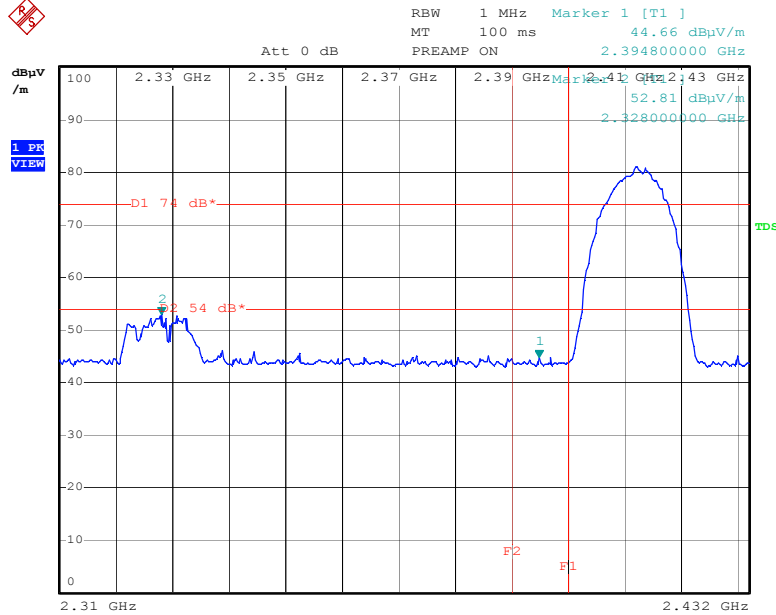

Date: 23.NOV.2015 10:12:41

Transmitter Radiated Bandedge Emissions Result								
Modulation	802.11b		Non-restricted Band Emissions					
Non-restricted Band (MHz)	Channel (MHz)	In-band PSD [i] (dBuV/100kHz)	NBE Freq. (MHz)	Out-band PSD [o] (dBuV/100kHz)	[i] - [o] (dB)	Limit (dB)	Level Type	Pol. note 1
2390-2400	2412	81.13	2394.800	44.66	36.47	20	PK	H

Note 1: Measurement worst emissions of receive antenna polarization: H (Horizontal) or V (Vertical)

Modulation	802.11b		Restricted Band Emissions					
Restricted BandBand (MHz)	Channel (MHz)	In-band PSD [i] (dBuV/100kHz)	RBE Freq. (MHz)	Measure Distance (m)	Out-Band Level (dBuV/m)	Limit (dB)	Level Type	Pol. note 1
2310-2390	2412	81.06	2328.000	3	52.81	74	PK	H
2310-2390	2412	/	2328.000	3	/	54	AV	H

Note 1: Measurement worst emissions of receive antenna polarization: H (Horizontal) or V (Vertical).
 Note 2: Average emission setting: RBW=1MHz; VBW ≥ 1/T, where T is "Pulse On Time", e.g., LE VBW ≥ 1/625us, VBW=3kHz.

802.11b CH High

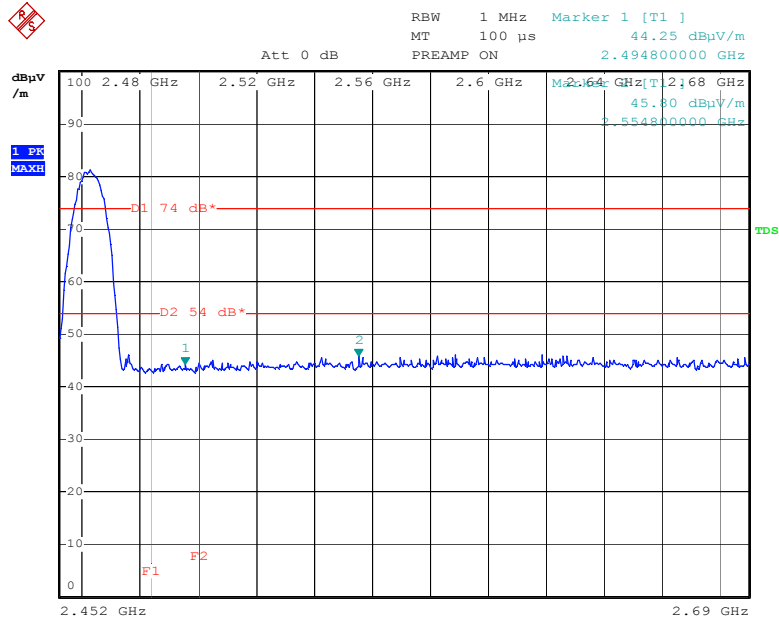

Date: 23.NOV.2015 11:01:13

Transmitter Radiated Bandedge Emissions Result								
Modulation	802.11b		Non-restricted Band Emissions					
Non-restricted Band (MHz)	Channel (MHz)	In-band PSD [i] (dBuV/100kHz)	NBE Freq. (MHz)	Out-band PSD [o] (dBuV/100kHz)	[i] - [o] (dB)	Limit (dB)	Level Type	Pol. note 1
2500-2690	2462	81.29	2554.800	45.80	35.49	20	PK	H

Note 1: Measurement worst emissions of receive antenna polarization: H (Horizontal) or V (Vertical)

Modulation	802.11b		Restricted Band Emissions					
Restricted BandBand (MHz)	Channel (MHz)	In-band PSD [i] (dBuV/100kHz)	RBE Freq. (MHz)	Measure Distance (m)	Out-Band Level (dBuV/m)	Limit (dB)	Level Type	Pol. note 1
2483.5-2500	2462	81.26	2494.800	3	44.25	74	PK	H
2483.5-2500	2462	/	2494.800	3	/	54	AV	H

Note 1: Measurement worst emissions of receive antenna polarization: H (Horizontal) or V (Vertical).
 Note 2: Average emission setting: RBW=1MHz; VBW ≥ 1/T, where T is "Pulse On Time", e.g., LE VBW ≥ 1/625us, VBW=3kHz.

802.11g CH Low

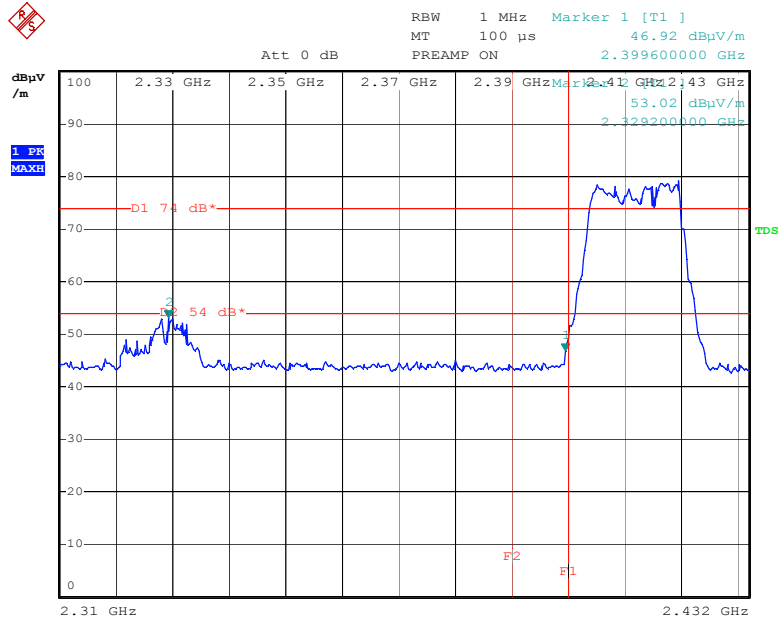

Date: 23.NOV.2015 10:17:03

Transmitter Radiated Bandedge Emissions Result								
Modulation	802.11g		Non-restricted Band Emissions					
Non-restricted Band (MHz)	Channel (MHz)	In-band PSD [i] (dBuV/100kHz)	NBE Freq. (MHz)	Out-band PSD [o] (dBuV/100kHz)	[i] - [o] (dB)	Limit (dB)	Level Type	Pol. note 1
2390-2400	2412	79.22	2399.600	46.92	32.30	20	PK	H

Note 1: Measurement worst emissions of receive antenna polarization: H (Horizontal) or V (Vertical)

Modulation	802.11g		Restricted Band Emissions					
Restricted BandBand (MHz)	Channel (MHz)	In-band PSD [i] (dBuV/100kHz)	RBE Freq. (MHz)	Measure Distance (m)	Out-Band Level (dBuV/m)	Limit (dB)	Level Type	Pol. note 1
2310-2390	2412	79.20	2329.200	3	53.02	74	PK	H
2310-2390	2412	/	2329.200	3	/	54	AV	H

Note 1: Measurement worst emissions of receive antenna polarization: H (Horizontal) or V (Vertical).
 Note 2: Average emission setting: RBW=1MHz; VBW ≥ 1/T, where T is "Pulse On Time", e.g., LE VBW ≥ 1/625us, VBW=3kHz.

802.11g CH High

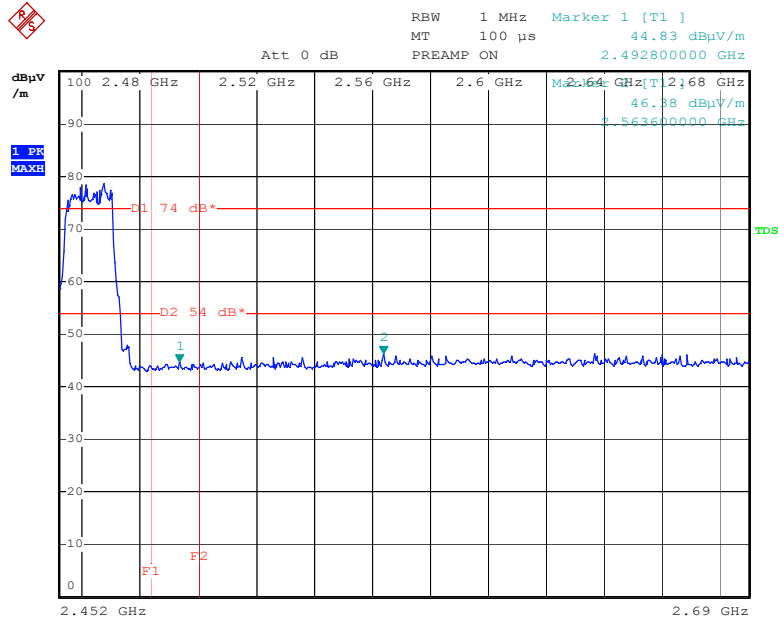

Date: 23.NOV.2015 11:05:30

Transmitter Radiated Bandedge Emissions Result								
Modulation	802.11g		Non-restricted Band Emissions					
Non-restricted Band (MHz)	Channel (MHz)	In-band PSD [i] (dBuV/100kHz)	NBE Freq. (MHz)	Out-band PSD [o] (dBuV/100kHz)	[i] - [o] (dB)	Limit (dB)	Level Type	Pol. note 1
2500-2690	2462	78.66	2563.600	46.38	32.28	20	PK	H

Note 1: Measurement worst emissions of receive antenna polarization: H (Horizontal) or V (Vertical)

Modulation	802.11g		Restricted Band Emissions					
Restricted BandBand (MHz)	Channel (MHz)	In-band PSD [i] (dBuV/100kHz)	RBE Freq. (MHz)	Measure Distance (m)	Out-Band Level (dBuV/m)	Limit (dB)	Level Type	Pol. note 1
2483.5-2500	2462	78.61	2492.800	3	44.83	74	PK	H
2483.5-2500	2462	/	2492.800	3		54	AV	H

Note 1: Measurement worst emissions of receive antenna polarization: H (Horizontal) or V (Vertical).
 Note 2: Average emission setting: RBW=1MHz; VBW ≥ 1/T, where T is "Pulse On Time", e.g., LE VBW ≥ 1/625us, VBW=3kHz.

802.11n HT20 CH Low Ant.0

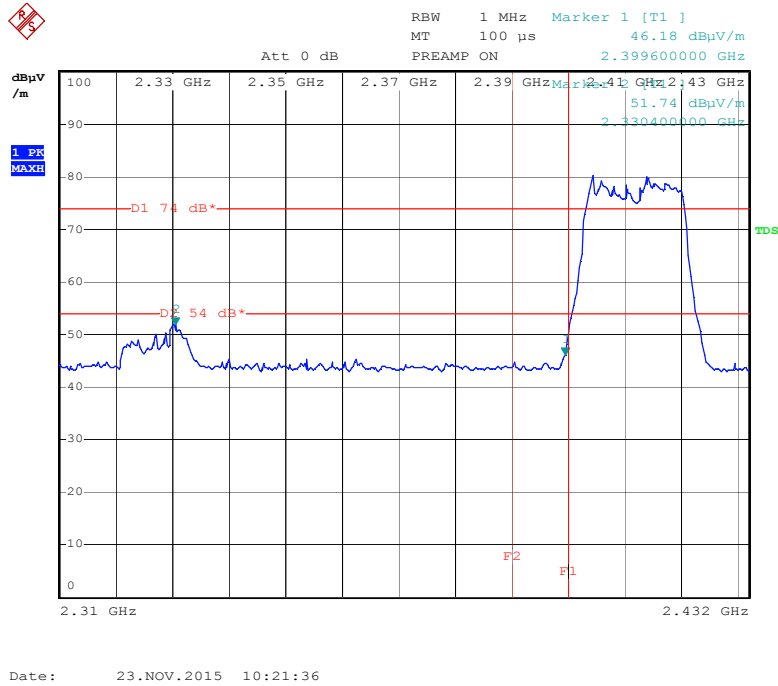

Transmitter Radiated Bandedge Emissions Result								
Modulation	802.11n 2.4G HT20		Non-restricted Band Emissions					
Non-restricted Band (MHz)	Channel (MHz)	In-band PSD [i] (dBuV/100kHz)	NBE Freq. (MHz)	Out-band PSD [o] (dBuV/100kHz)	[i] - [o] (dB)	Limit (dB)	Level Type	Pol. note 1
2390-2400	2412	80.12	2399.600	46.18	33.94	20	PK	H

Note 1: Measurement worst emissions of receive antenna polarization: H (Horizontal) or V (Vertical)

Modulation	802.11n 2.4G HT20		Restricted Band Emissions					
Restricted Band (MHz)	Channel (MHz)	In-band PSD [i] (dBuV/100kHz)	RBE Freq. (MHz)	Measure Distance (m)	Out-Band Level (dBuV/m)	Limit (dB)	Level Type	Pol. note 1
2310-2390	2412	79.98	2330.400	3	51.74	74	PK	H
2310-2390	2412	/	2330.400	3		54	AV	H

Note 1: Measurement worst emissions of receive antenna polarization: H (Horizontal) or V (Vertical).
 Note 2: Average emission setting: RBW=1MHz; VBW ≥ 1/T, where T is "Pulse On Time", e.g., LE VBW ≥ 1/625us, VBW=3kHz.

802.11n HT20 CH High Ant.0

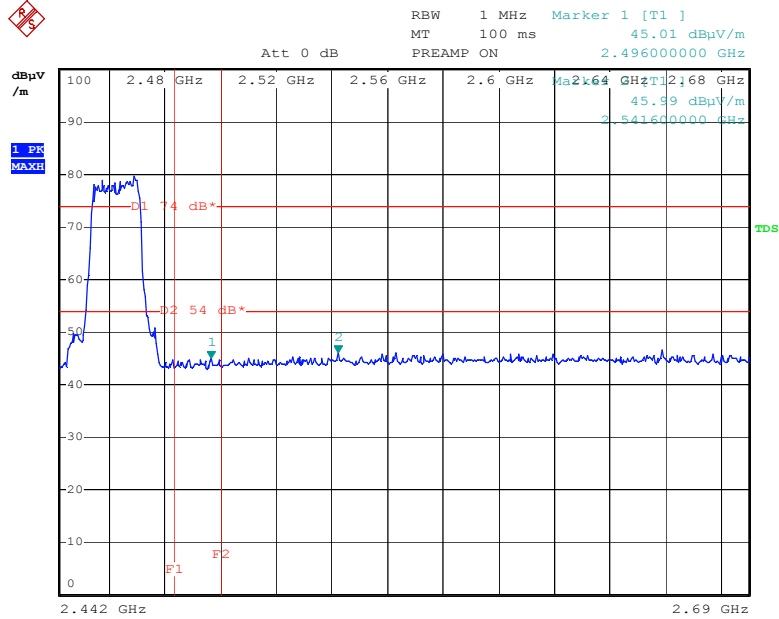

Date: 23.NOV.2015 12:57:20

Transmitter Radiated Bandedge Emissions Result								
Modulation	802.11n 2.4G HT20		Non-restricted Band Emissions					
Non-restricted Band (MHz)	Channel (MHz)	In-band PSD [i] (dBuV/100kHz)	NBE Freq. (MHz)	Out-band PSD [o] (dBuV/100kHz)	[i] - [o] (dB)	Limit (dB)	Level Type	Pol. note 1
2500-2690	2462	79.66	2541.600	45.99	33.67	20	PK	H

Note 1: Measurement worst emissions of receive antenna polarization: H (Horizontal) or V (Vertical)

Modulation	802.11n 2.4G HT20		Restricted Band Emissions					
Restricted BandBand (MHz)	Channel (MHz)	In-band PSD [i] (dBuV/100kHz)	RBE Freq. (MHz)	Measure Distance (m)	Out-Band Level (dBuV/m)	Limit (dB)	Level Type	Pol. note 1
2483.5-2500	2462	79.61	2496.000	3	45.01	74	PK	H
2483.5-2500	2462	/	2496.000	3		54	AV	H

Note 1: Measurement worst emissions of receive antenna polarization: H (Horizontal) or V (Vertical).
 Note 2: Average emission setting: RBW=1MHz; VBW ≥ 1/T, where T is "Pulse On Time", e.g., LE VBW ≥ 1/625us, VBW=3kHz.

802.11n HT40 CH Low Ant.0

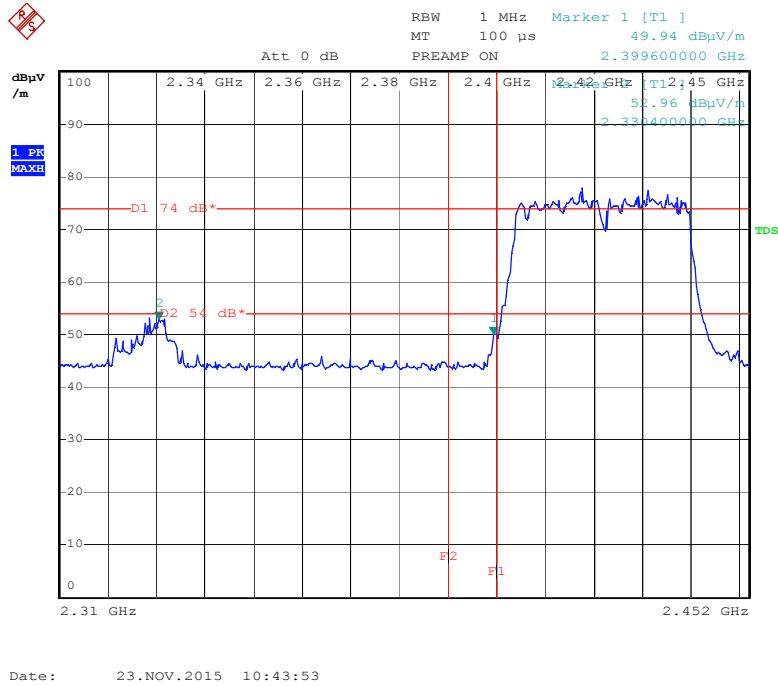

Date: 23.NOV.2015 10:43:53

Transmitter Radiated Bandedge Emissions Result								
Modulation	802.11n 2.4G HT40		Non-restricted Band Emissions					
Non-restricted Band (MHz)	Channel (MHz)	In-band PSD [i] (dBuV/100kHz)	NBE Freq. (MHz)	Out-band PSD [o] (dBuV/100kHz)	[i] - [o] (dB)	Limit (dB)	Level Type	Pol. note 1
2390-2400	2422	77.89	2399.600	49.94	27.95	20	PK	H

Note 1: Measurement worst emissions of receive antenna polarization: H (Horizontal) or V (Vertical)

Modulation	802.11n 2.4G HT40		Restricted Band Emissions					
Restricted BandBand (MHz)	Channel (MHz)	In-band PSD [i] (dBuV/100kHz)	RBE Freq. (MHz)	Measure Distance (m)	Out-Band Level (dBuV/m)	Limit (dB)	Level Type	Pol. note 1
2310-2390	2422	78.01	2330.400	3	52.96	74	PK	H
2310-2390	2422	/	2330.400	3		54	AV	H

Note 1: Measurement worst emissions of receive antenna polarization: H (Horizontal) or V (Vertical).

Note 2: Average emission setting: RBW=1MHz; VBW ≥ 1/T, where T is "Pulse On Time", e.g., LE VBW ≥ 1/625us, VBW=3kHz.

802.11n HT40 CH High Ant.0

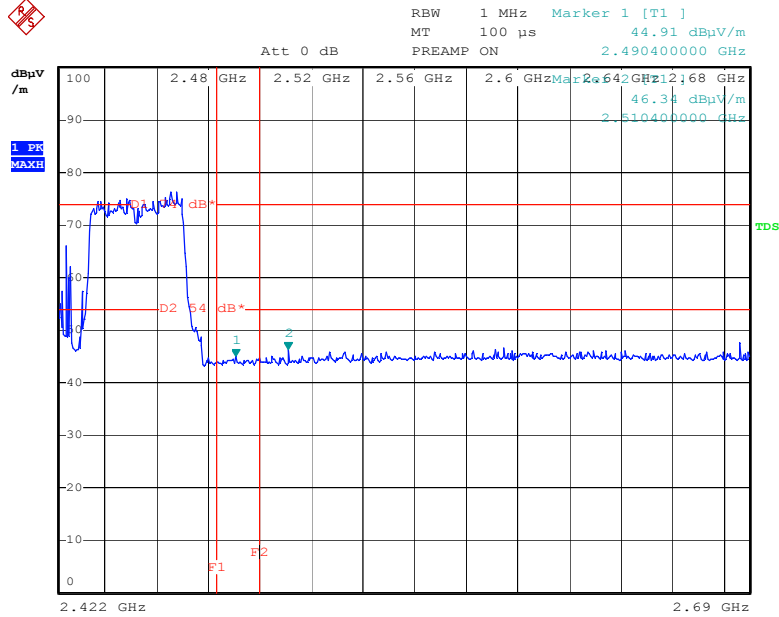

Date: 23.NOV.2015 13:04:57

Transmitter Radiated Bandedge Emissions Result								
Modulation	802.11n 2.4G HT40		Non-restricted Band Emissions					
Non-restricted Band (MHz)	Channel (MHz)	In-band PSD [i] (dBuV/100kHz)	NBE Freq. (MHz)	Out-band PSD [o] (dBuV/100kHz)	[i] - [o] (dB)	Limit (dB)	Level Type	Pol. note 1
2500-2690	2452	76.31	2510.400	46.34	29.97	20	PK	H

Note 1: Measurement worst emissions of receive antenna polarization: H (Horizontal) or V (Vertical)

Modulation	802.11n 2.4G HT40		Restricted Band Emissions					
Restricted Band (MHz)	Channel (MHz)	In-band PSD [i] (dBuV/100kHz)	RBE Freq. (MHz)	Measure Distance (m)	Out-Band Level (dBuV/m)	Limit (dB)	Level Type	Pol. note 1
2483.5-2500	2452	76.25	2490.400	3	44.91	74	PK	H
2483.5-2500	2452	/	2490.400	3		54	AV	H

Note 1: Measurement worst emissions of receive antenna polarization: H (Horizontal) or V (Vertical).
 Note 2: Average emission setting: RBW=1MHz; VBW ≥ 1/T, where T is "Pulse On Time", e.g., LE VBW ≥ 1/625us, VBW=3kHz.

802.11n HT20 CH Low Ant.1

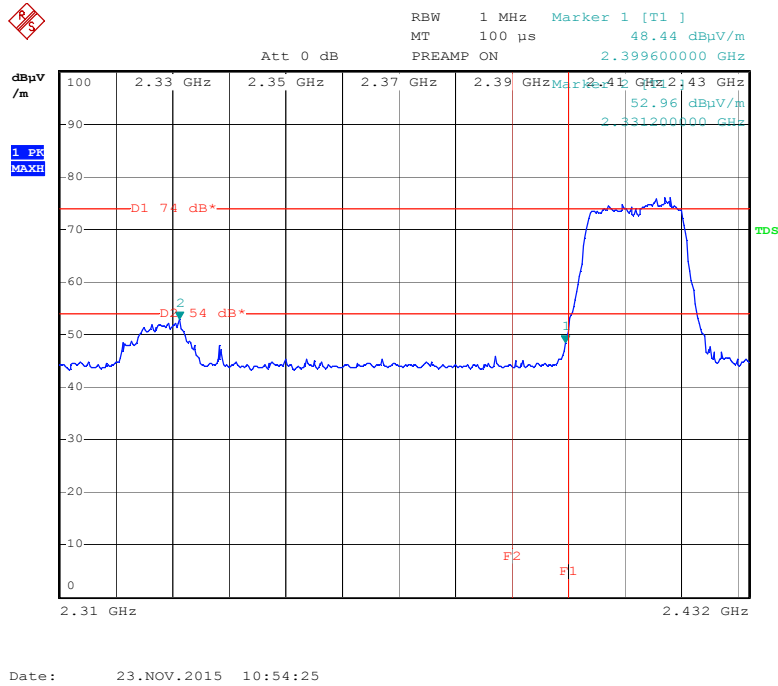

Transmitter Radiated Bandedge Emissions Result								
Modulation	802.11n 2.4G HT20		Non-restricted Band Emissions					
Non-restricted Band (MHz)	Channel (MHz)	In-band PSD [i] (dBuV/100kHz)	NBE Freq. (MHz)	Out-band PSD [o] (dBuV/100kHz)	[i] - [o] (dB)	Limit (dB)	Level Type	Pol. note 1
2390-2400	2412	75.91	2399.600	48.44	27.47	20	PK	H

Note 1: Measurement worst emissions of receive antenna polarization: H (Horizontal) or V (Vertical)

Modulation	802.11n 2.4G HT20		Restricted Band Emissions					
Restricted Band (MHz)	Channel (MHz)	In-band PSD [i] (dBuV/100kHz)	RBE Freq. (MHz)	Measure Distance (m)	Out-Band Level (dBuV/m)	Limit (dB)	Level Type	Pol. note 1
2310-2390	2412	75.90	2331.200	3	52.96	74	PK	H
2310-2390	2412	/	2331.200	3		54	AV	H

Note 1: Measurement worst emissions of receive antenna polarization: H (Horizontal) or V (Vertical).
 Note 2: Average emission setting: RBW=1MHz; VBW ≥ 1/T, where T is "Pulse On Time", e.g., LE VBW ≥ 1/625us, VBW=3kHz.

802.11n HT20 CH High Ant.1

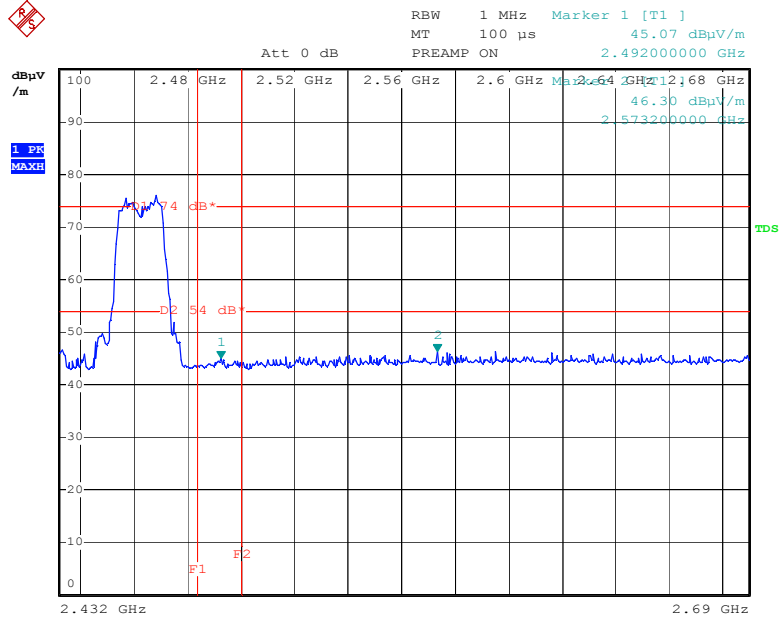

Date: 23.NOV.2015 13:18:40

Transmitter Radiated Bandedge Emissions Result								
Modulation	802.11n 2.4G HT20		Non-restricted Band Emissions					
Non-restricted Band (MHz)	Channel (MHz)	In-band PSD [i] (dBuV/100kHz)	NBE Freq. (MHz)	Out-band PSD [o] (dBuV/100kHz)	[i] - [o] (dB)	Limit (dB)	Level Type	Pol. note 1
2500-2690	2462	75.86	2573.200	46.30	29.56	20	PK	H

Note 1: Measurement worst emissions of receive antenna polarization: H (Horizontal) or V (Vertical)

Modulation	802.11n 2.4G HT20		Restricted Band Emissions					
Restricted BandBand (MHz)	Channel (MHz)	In-band PSD [i] (dBuV/100kHz)	RBE Freq. (MHz)	Measure Distance (m)	Out-Band Level (dBuV/m)	Limit (dB)	Level Type	Pol. note 1
2483.5-2500	2462	75.88	2492.000	3	45.07	74	PK	H
2483.5-2500	2462	/	2492.000	3		54	AV	H

Note 1: Measurement worst emissions of receive antenna polarization: H (Horizontal) or V (Vertical).

Note 2: Average emission setting: RBW=1MHz; VBW ≥ 1/T, where T is "Pulse On Time", e.g., LE VBW ≥ 1/625us, VBW=3kHz.

802.11n HT40 CH Low Ant.1

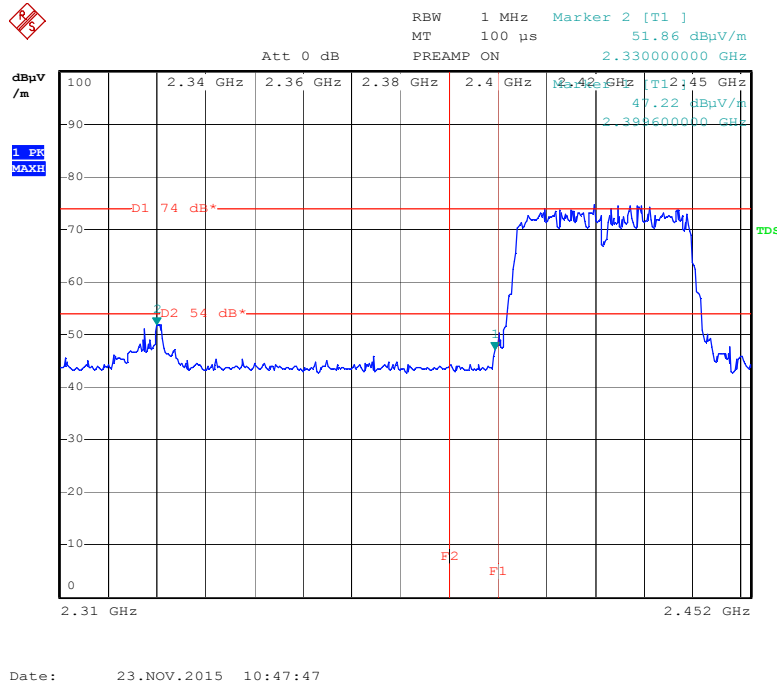

Transmitter Radiated Bandedge Emissions Result								
Modulation	802.11n 2.4G HT20		Non-restricted Band Emissions					
Non-restricted Band (MHz)	Channel (MHz)	In-band PSD [i] (dBuV/100kHz)	NBE Freq. (MHz)	Out-band PSD [o] (dBuV/100kHz)	[i] - [o] (dB)	Limit (dB)	Level Type	Pol. note 1
2390-2400	2422	74.65	2399.600	47.22	27.43	20	PK	H

Note 1: Measurement worst emissions of receive antenna polarization: H (Horizontal) or V (Vertical)

Modulation	802.11n 2.4G HT20		Restricted Band Emissions					
Restricted BandBand (MHz)	Channel (MHz)	In-band PSD [i] (dBuV/100kHz)	RBE Freq. (MHz)	Measure Distance (m)	Out-Band Level (dBuV/m)	Limit (dB)	Level Type	Pol. note 1
2310-2390	2422	74.56	2330.000	3	51.86	74	PK	H
2310-2390	2422	/	2330.000	3		54	AV	H

Note 1: Measurement worst emissions of receive antenna polarization: H (Horizontal) or V (Vertical).
 Note 2: Average emission setting: RBW=1MHz; VBW ≥ 1/T, where T is "Pulse On Time", e.g., LE VBW ≥ 1/625us, VBW=3kHz.

802.11n HT40 CH High Ant.1

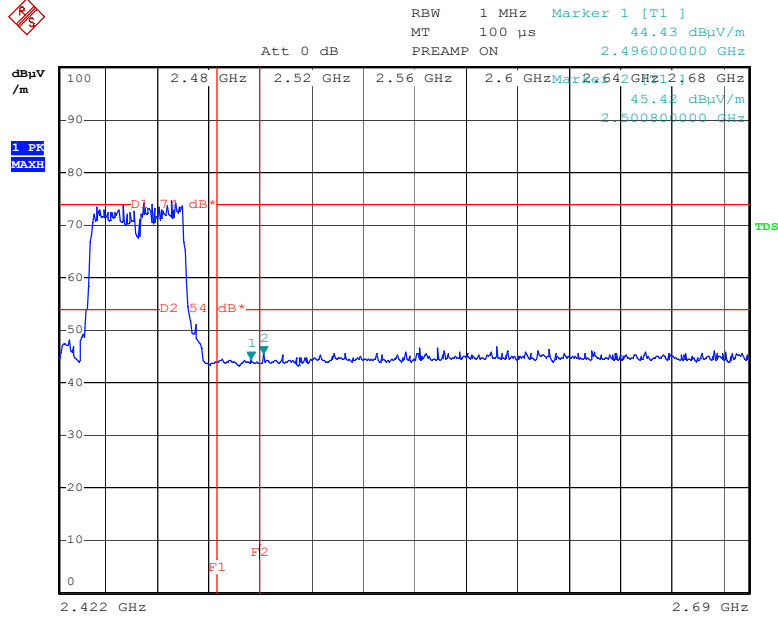

Date: 23.NOV.2015 13:12:35

Transmitter Radiated Bandedge Emissions Result								
Modulation	802.11n 2.4G HT40		Non-restricted Band Emissions					
Non-restricted Band (MHz)	Channel (MHz)	In-band PSD [i] (dBuV/100kHz)	NBE Freq. (MHz)	Out-band PSD [o] (dBuV/100kHz)	[i] - [o] (dB)	Limit (dB)	Level Type	Pol. note 1
2500-2690	2452	74.59	2500.800	45.42	29.17	20	PK	H

Note 1: Measurement worst emissions of receive antenna polarization: H (Horizontal) or V (Vertical)

Modulation	802.11n 2.4G HT40		Restricted Band Emissions					
Restricted BandBand (MHz)	Channel (MHz)	In-band PSD [i] (dBuV/100kHz)	RBE Freq. (MHz)	Measure Distance (m)	Out-Band Level (dBuV/m)	Limit (dB)	Level Type	Pol. note 1
2483.5-2500	2452	74.58	2496.000	3	44.43	74	PK	H
2483.5-2500	2452	/	2496.000	3		54	AV	H

Note 1: Measurement worst emissions of receive antenna polarization: H (Horizontal) or V (Vertical).

Note 2: Average emission setting: RBW=1MHz; VBW ≥ 1/T, where T is "Pulse On Time", e.g., LE VBW ≥ 1/625us, VBW=3kHz.

IEEE 802.11b Channel: Low

Freq. (MHz)	Emission (dBuV/m) Peak Detector	HORIZ / VERT	Limits (dBuV/m) Peak / Average	Margin (dB)
4824.00	48.12	HORZ	74.0 / 54.0	-25.88
4824.00	47.63	VERT	74.0 / 54.0	-26.37
7236.00	48.05	HORZ	74.0 / 54.0	-25.95
7236.08	47.45	VERT	74.0 / 54.0	-26.55
9648.02	48.11	HORZ	74.0 / 54.0	-25.89
9648.10	47.38	VERT	74.0 / 54.0	-26.62
24120.04	-	HORZ	74.0 / 54.0	-
24120.20	-	VERT	74.0 / 54.0	-

IEEE 802.11b Channel: Mid

Freq. (MHz)	Emission (dBuV/m) Peak Detector	HORIZ / VERT	Limits (dBuV/m) Peak / Average	Margin (dB)
4874.00	48.38	HORZ	74.0 / 54.0	-25.62
4874.00	47.71	VERT	74.0 / 54.0	-26.29
7311.00	48.25	HORZ	74.0 / 54.0	-25.75
7311.02	47.63	VERT	74.0 / 54.0	-26.37
9748.10	48.45	HORZ	74.0 / 54.0	-25.55
9748.00	47.59	VERT	74.0 / 54.0	-26.41
24370.10	-	HORZ	74.0 / 54.0	-
24370.00	-	VERT	74.0 / 54.0	-

IEEE 802.11b Channel: High

Freq. (MHz)	Emission (dBuV/m) Peak Detector	HORIZ / VERT	Limits (dBuV/m) Peak / Average	Margin (dB)
4924.00	48.91	HORZ	74.0 / 54.0	-25.09
4924.00	48.16	VERT	74.0 / 54.0	-25.84
7386.12	48.76	HORZ	74.0 / 54.0	-25.24
7368.00	47.95	VERT	74.0 / 54.0	-26.05
9848.00	48.34	HORZ	74.0 / 54.0	-25.66
9848.00	47.65	VERT	74.0 / 54.0	-26.35
24620.11	-	HORZ	74.0 / 54.0	-
24620.00	-	VERT	74.0 / 54.0	-

- Note:**
- (1) All Reading Levels below 1GHz are Quasi-Peak, above are peak and average value.
 - (2) Emission Level = Reading Level + Probe Factor + Cable Loss.
 - (3) Span shall wide enough to fully capture the emission being measured;
Set RBW = 1 MHz, VBW= 3MHz for f > 1 GHz for peak measurement.
For average measurement: VBW = 10 Hz, when duty cycle is no less than 98 percent. $VBW \geq 1/T$, when duty cycle is less than 98 percent where T is the minimum transmission duration over which the transmitter is on and is transmitting at its maximum power control level for the tested mode of operation.
 - (4) The average measurement was not performed when the peak measured data under the limit of average detection. If the readings given are average, peak measurement should also be supplied.
 - (5) Where an emission level is indicated by a -, levels had a margin greater than 20 dB when compared to the limit.

IEEE 802.11g Channel: Low

Freq. (MHz)	Emission (dBuV/m) Peak	HORIZ / VERT	Limits (dBuV/m) Peak / Average	Margin (dB)
4824.00	47.88	HORZ	74.0 / 54.0	-26.12
4824.00	47.65	VERT	74.0 / 54.0	-26.35
7236.00	47.78	HORZ	74.0 / 54.0	-26.22
7236.08	47.44	VERT	74.0 / 54.0	-26.56
9648.02	48.59	HORZ	74.0 / 54.0	-25.41
9648.10	47.31	VERT	74.0 / 54.0	-26.69
24120.04	-	HORZ	74.0 / 54.0	-
24120.20	-	VERT	74.0 / 54.0	-

IEEE 802.11g Channel: Mid

Freq. (MHz)	Emission (dBuV/m) Peak	HORIZ / VERT	Limits (dBuV/m) Peak / Average	Margin (dB)
4874.00	48.11	HORZ	74.0 / 54.0	-25.89
4874.00	47.95	VERT	74.0 / 54.0	-26.05
7311.00	48.02	HORZ	74.0 / 54.0	-25.98
7311.02	47.68	VERT	74.0 / 54.0	-26.32
9748.10	47.98	HORZ	74.0 / 54.0	-26.02
9748.00	47.51	VERT	74.0 / 54.0	-26.49
24370.10	-	HORZ	74.0 / 54.0	-
24370.00	-	VERT	74.0 / 54.0	-

IEEE 802.11g Channel: High

Freq. (MHz)	Emission (dBuV/m) Peak	HORIZ / VERT	Limits (dBuV/m) Peak / Average	Margin (dB)
4924.00	48.21	HORZ	74.0 / 54.0	-25.79
4924.00	47.98	VERT	74.0 / 54.0	-26.02
7386.12	48.16	HORZ	74.0 / 54.0	-25.84
7368.00	47.83	VERT	74.0 / 54.0	-26.17
9848.00	48.03	HORZ	74.0 / 54.0	-25.97
9848.00	47.76	VERT	74.0 / 54.0	-26.24
24620.11	-	HORZ	74.0 / 54.0	-
24620.00	-	VERT	74.0 / 54.0	-

- Note:**
- (1) All Reading Levels below 1GHz are Quasi-Peak, above are peak and average value.
 - (2) Emission Level = Reading Level + Probe Factor + Cable Loss.
 - (3) Span shall wide enough to fully capture the emission being measured;
Set RBW = 1 MHz, VBW= 3MHz for f > 1 GHz for peak measurement.
For average measurement: VBW = 10 Hz, when duty cycle is no less than 98 percent. $VBW \geq 1/T$, when duty cycle is less than 98 percent where T is the minimum transmission duration over which the transmitter is on and is transmitting at its maximum power control level for the tested mode of operation.
 - (4) The average measurement was not performed when the peak measured data under the limit of average detection. If the readings given are average, peak measurement should also be supplied.
 - (5) Where an emission level is indicated by a -, levels had a margin greater than 20 dB when compared to the limit.

IEEE 802.11n MCS8 20MHz Ant.0 Channel: Low

Freq. (MHz)	Emission (dBuV/m) Peak /Av	HORIZ / VERT	Limits (dBuV/m) Peak / Average	Margin (dB)
4824.00	48.03	HORZ	74.0 / 54.0	-25.97
4824.00	47.79	VERT	74.0 / 54.0	-26.21
7236.00	48.01	HORZ	74.0 / 54.0	-25.99
7236.08	47.66	VERT	74.0 / 54.0	-26.34
9648.02	47.93	HORZ	74.0 / 54.0	-26.07
9648.10	47.48	VERT	74.0 / 54.0	-26.52
24120.04	-	HORZ	74.0 / 54.0	-
24120.20	-	VERT	74.0 / 54.0	-

IEEE 802.11n MCS8 20MHz Ant.0 Channel: Mid

Freq. (MHz)	Emission (dBuV/m) Peak	HORIZ / VERT	Limits (dBuV/m) Peak / Average	Margin (dB)
4874.00	48.11	HORZ	74.0 / 54.0	-25.89
4874.00	47.81	VERT	74.0 / 54.0	-26.19
7311.00	48.06	HORZ	74.0 / 54.0	-25.94
7311.02	47.69	VERT	74.0 / 54.0	-26.31
9748.10	47.95	HORZ	74.0 / 54.0	-26.05
9748.00	47.53	VERT	74.0 / 54.0	-26.47
24370.10	-	HORZ	74.0 / 54.0	-
24370.00	-	VERT	74.0 / 54.0	-

IEEE 802.11n MCS8 20MHz Ant.0 Channel: High

Freq. (MHz)	Emission (dBuV/m) Peak /Av	HORIZ / VERT	Limits (dBuV/m) Peak / Average	Margin (dB)
4924.00	48.20	HORZ	74.0 / 54.0	-25.80
4924.00	47.85	VERT	74.0 / 54.0	-26.15
7386.12	48.13	HORZ	74.0 / 54.0	-25.87
7368.00	47.46	VERT	74.0 / 54.0	-26.54
9848.00	48.01	HORZ	74.0 / 54.0	-25.99
9848.00	47.35	VERT	74.0 / 54.0	-26.65
24620.11	-	HORZ	74.0 / 54.0	-
24620.00	-	VERT	74.0 / 54.0	-

- Note:**
- (1) All Reading Levels below 1GHz are Quasi-Peak, above are peak and average value.
 - (2) Emission Level = Reading Level + Probe Factor + Cable Loss.
 - (3) Span shall wide enough to fully capture the emission being measured;
Set RBW = 1 MHz, VBW= 3MHz for $f > 1$ GHz for peak measurement.
For average measurement: VBW = 10 Hz, when duty cycle is no less than 98 percent. $VBW \geq 1/T$, when duty cycle is less than 98 percent where T is the minimum transmission duration over which the transmitter is on and is transmitting at its maximum power control level for the tested mode of operation.
 - (4) The average measurement was not performed when the peak measured data under the limit of average detection. If the readings given are average, peak measurement should also be supplied.
 - (5) Where an emission level is indicated by a -, levels had a margin greater than 20 dB when compared to the limit.

IEEE 802.11n MCS8 40MHz Ant.0 Channel: Low

Freq. (MHz)	Emission (dBuV/m) Peak /Av	HORIZ / VERT	Limits (dBuV/m) Peak / Average	Margin (dB)
4844.00	48.08	HORZ	74.0 / 54.0	-25.92
4844.00	47.78	VERT	74.0 / 54.0	-26.22
7266.00	48.02	HORZ	74.0 / 54.0	-25.98
7266.08	47.65	VERT	74.0 / 54.0	-26.35
9688.02	47.87	HORZ	74.0 / 54.0	-26.13
9688.10	47.31	VERT	74.0 / 54.0	-26.69
24220.04	-	HORZ	74.0 / 54.0	-
24220.20	-	VERT	74.0 / 54.0	-

IEEE 802.11n MCS8 40MHz Ant.0 Channel: Mid

Freq. (MHz)	Emission (dBuV/m) Peak	HORIZ / VERT	Limits (dBuV/m) Peak / Average	Margin (dB)
4874.00	48.09	HORZ	74.0 / 54.0	-25.91
4874.00	47.77	VERT	74.0 / 54.0	-26.23
7311.00	47.94	HORZ	74.0 / 54.0	-26.06
7311.02	47.61	VERT	74.0 / 54.0	-26.39
9748.10	47.78	HORZ	74.0 / 54.0	-26.22
9748.00	47.52	VERT	74.0 / 54.0	-26.48
24370.10	-	HORZ	74.0 / 54.0	-
24370.00	-	VERT	74.0 / 54.0	-

IEEE 802.11n MCS8 40MHz Ant.0 Channel: High

Freq. (MHz)	Emission (dBuV/m) Peak /Av	HORIZ / VERT	Limits (dBuV/m) Peak / Average	Margin (dB)
4904.00	48.11	HORZ	74.0 / 54.0	-25.89
4904.00	47.85	VERT	74.0 / 54.0	-26.15
7356.12	48.05	HORZ	74.0 / 54.0	-25.95
7356.00	47.76	VERT	74.0 / 54.0	-26.24
9808.00	47.99	HORZ	74.0 / 54.0	-26.01
9808.00	47.33	VERT	74.0 / 54.0	-26.67
24520.11	-	HORZ	74.0 / 54.0	-
24520.00	-	VERT	74.0 / 54.0	-

- Note:**
- (1) All Reading Levels below 1GHz are Quasi-Peak, above are peak and average value.
 - (2) Emission Level = Reading Level + Probe Factor + Cable Loss.
 - (3) Span shall wide enough to fully capture the emission being measured;
Set RBW = 1 MHz, VBW= 3MHz for f > 1 GHz for peak measurement.
For average measurement: VBW = 10 Hz, when duty cycle is no less than 98 percent. $VBW \geq 1/T$, when duty cycle is less than 98 percent where T is the minimum transmission duration over which the transmitter is on and is transmitting at its maximum power control level for the tested mode of operation.
 - (4) The average measurement was not performed when the peak measured data under the limit of average detection. If the readings given are average, peak measurement should also be supplied.
 - (5) Where an emission level is indicated by a -, levels had a margin greater than 20 dB when compared to the limit.

IEEE 802.11n MCS8 20MHz Ant.1 Channel: Low

Freq. (MHz)	Emission (dBuV/m) Peak /Av	HORIZ / VERT	Limits (dBuV/m) Peak / Average	Margin (dB)
4824.00	48.01	HORZ	74.0 / 54.0	-25.99
4824.00	47.66	VERT	74.0 / 54.0	-26.34
7236.00	47.83	HORZ	74.0 / 54.0	-26.17
7236.08	47.43	VERT	74.0 / 54.0	-26.57
9648.02	47.76	HORZ	74.0 / 54.0	-26.24
9648.10	47.26	VERT	74.0 / 54.0	-26.74
24120.04	-	HORZ	74.0 / 54.0	-
24120.20	-	VERT	74.0 / 54.0	-

IEEE 802.11n MCS8 20MHz Ant.1 Channel: Mid

Freq. (MHz)	Emission (dBuV/m) Peak	HORIZ / VERT	Limits (dBuV/m) Peak / Average	Margin (dB)
4874.00	48.02	HORZ	74.0 / 54.0	-25.98
4874.00	47.65	VERT	74.0 / 54.0	-26.35
7311.00	48.01	HORZ	74.0 / 54.0	-25.99
7311.02	47.39	VERT	74.0 / 54.0	-26.61
9748.10	47.81	HORZ	74.0 / 54.0	-26.19
9748.00	47.31	VERT	74.0 / 54.0	-26.69
24370.10	-	HORZ	74.0 / 54.0	-
24370.00	-	VERT	74.0 / 54.0	-

IEEE 802.11n MCS8 20MHz Ant.1 Channel: High

Freq. (MHz)	Emission (dBuV/m) Peak /Av	HORIZ / VERT	Limits (dBuV/m) Peak / Average	Margin (dB)
4924.00	48.05	HORZ	74.0 / 54.0	-25.95
4924.00	47.73	VERT	74.0 / 54.0	-26.27
7386.12	47.89	HORZ	74.0 / 54.0	-26.11
7368.00	47.31	VERT	74.0 / 54.0	-26.69
9848.00	47.65	HORZ	74.0 / 54.0	-26.35
9848.00	47.04	VERT	74.0 / 54.0	-26.96
24620.11	-	HORZ	74.0 / 54.0	-
24620.00	-	VERT	74.0 / 54.0	-

- Note:**
- (1) All Reading Levels below 1GHz are Quasi-Peak, above are peak and average value.
 - (2) Emission Level = Reading Level + Probe Factor + Cable Loss.
 - (3) Span shall wide enough to fully capture the emission being measured;
Set RBW = 1 MHz, VBW= 3MHz for $f > 1$ GHz for peak measurement.
For average measurement: VBW = 10 Hz, when duty cycle is no less than 98 percent. $VBW \geq 1/T$, when duty cycle is less than 98 percent where T is the minimum transmission duration over which the transmitter is on and is transmitting at its maximum power control level for the tested mode of operation.
 - (4) The average measurement was not performed when the peak measured data under the limit of average detection. If the readings given are average, peak measurement should also be supplied.
 - (5) Where an emission level is indicated by a -, levels had a margin greater than 20 dB when compared to the limit.

IEEE 802.11n MCS8 40MHz Ant.1 Channel: Low

Freq. (MHz)	Emission (dBuV/m) Peak /Av	HORIZ / VERT	Limits (dBuV/m) Peak / Average	Margin (dB)
4844.00	48.02	HORZ	74.0 / 54.0	-25.98
4844.00	47.66	VERT	74.0 / 54.0	-26.34
7266.00	47.67	HORZ	74.0 / 54.0	-26.33
7266.08	47.34	VERT	74.0 / 54.0	-26.66
9688.02	47.65	HORZ	74.0 / 54.0	-26.35
9688.10	47.12	VERT	74.0 / 54.0	-26.88
24220.04	-	HORZ	74.0 / 54.0	-
24220.20	-	VERT	74.0 / 54.0	-

IEEE 802.11n MCS8 40MHz Ant.1 Channel: Mid

Freq. (MHz)	Emission (dBuV/m) Peak	HORIZ / VERT	Limits (dBuV/m) Peak / Average	Margin (dB)
4874.00	48.02	HORZ	74.0 / 54.0	-25.98
4874.00	47.61	VERT	74.0 / 54.0	-26.39
7311.00	47.88	HORZ	74.0 / 54.0	-26.12
7311.02	47.44	VERT	74.0 / 54.0	-26.56
9748.10	47.61	HORZ	74.0 / 54.0	-26.39
9748.00	47.36	VERT	74.0 / 54.0	-26.64
24370.10	-	HORZ	74.0 / 54.0	-
24370.00	-	VERT	74.0 / 54.0	-

IEEE 802.11n MCS8 40MHz Ant.1 Channel: High

Freq. (MHz)	Emission (dBuV/m) Peak /Av	HORIZ / VERT	Limits (dBuV/m) Peak / Average	Margin (dB)
4904.00	48.02	HORZ	74.0 / 54.0	-25.98
4904.00	47.64	VERT	74.0 / 54.0	-26.36
7356.12	47.73	HORZ	74.0 / 54.0	-26.27
7356.00	47.54	VERT	74.0 / 54.0	-26.46
9808.00	47.83	HORZ	74.0 / 54.0	-26.17
9808.00	47.20	VERT	74.0 / 54.0	-26.80
24520.11	-	HORZ	74.0 / 54.0	-
24520.00	-	VERT	74.0 / 54.0	-

- Note:**
- (1) All Reading Levels below 1GHz are Quasi-Peak, above are peak and average value.
 - (2) Emission Level = Reading Level + Probe Factor + Cable Loss.
 - (3) Span shall wide enough to fully capture the emission being measured;
Set RBW = 1 MHz, VBW= 3MHz for f > 1 GHz for peak measurement.
For average measurement: VBW = 10 Hz, when duty cycle is no less than 98 percent. $VBW \geq 1/T$, when duty cycle is less than 98 percent where T is the minimum transmission duration over which the transmitter is on and is transmitting at its maximum power control level for the tested mode of operation.
 - (4) The average measurement was not performed when the peak measured data under the limit of average detection. If the readings given are average, peak measurement should also be supplied.
 - (5) Where an emission level is indicated by a -, levels had a margin greater than 20 dB when compared to the limit.

General Radiated Emission Data

Product	: WIRELESS ADAPTER	Test Mode	: IEEE 802.11b/g/n
Test Item	: Spurious Radiated Emissions	Temperature	: 25 °C
Test Voltage	: DC 5V (From Host)	Humidity	: 56%RH
Test Result	: PASS		

For Frequency below 30MHz

Freq. (MHz)	Emission (dBuV/m) QP Detector	HORIZ / VERT	Limits (dBuV/m)	Margin (dB)
N/A				
N/A				
N/A				
N/A				
N/A				

- Note:**
- (1) All Readings below 1GHz are Quasi-Peak, above are performed with peak and/or average measurements as necessary.
 - (2) "N/A" remark, if no specific emissions from the EUT are recorded (ie: margin>20dB from the applicable limit) and considered that's already beyond the background noise floor.
 - (3) Emission Level = Reading Level + Probe Factor + Cable Loss.

For Frequency from 30MHz to 1GHz

Freq. (MHz)	Emission (dBuV/m) QP Detector	HORIZ / VERT	Limits (dBuV/m)	Margin (dB)
240.000	31.81	HORZ	46.0	-14.19
33.120	27.43	VERT	40.0	-12.57
283.360	28.05	HORZ	46.0	-17.95
277.640	22.35	VERT	46.0	-23.65
722.360	32.98	HORZ	46.0	-13.02
283.200	23.58	VERT	46.0	-22.42

- Note:**
- (1) All Readings below 1GHz are Quasi-Peak, above are performed with peak and/or average measurements as necessary.
 - (2) "N/A" remark, if no specific emissions from the EUT are recorded (ie: margin>20dB from the applicable limit) and considered that's already beyond the background noise floor.
 - (3) Emission Level = Reading Level + Probe Factor + Cable Loss.

Conducted Emission

FCC 15.209

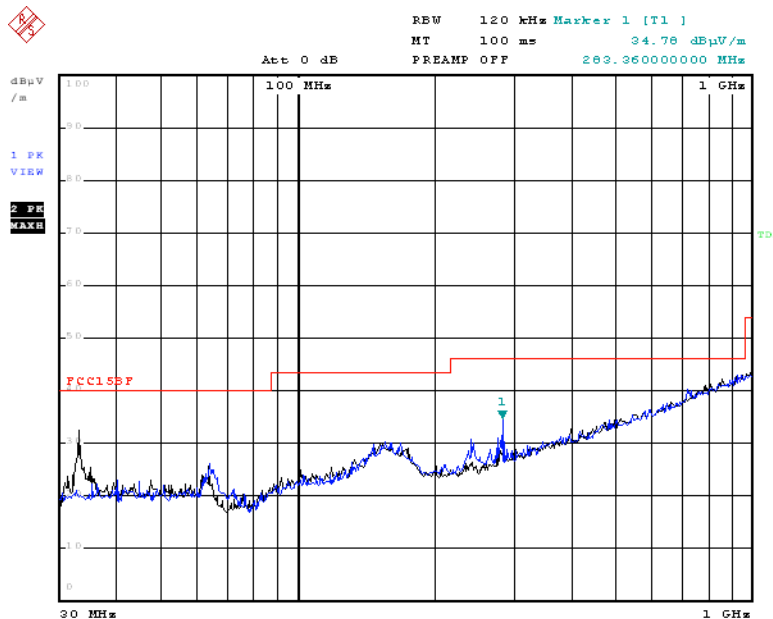

Date: 16.NOV.2015 14:35:06

7. RF Exposure Requirements

7.1 Test Equipment

Please refer to Section 10 this report.

7.2 Limit

According to FCC 15.247(e)(i) and FCC 1.1307(b)(1), Systems operating under provisions of this section shall be operated in a manner that ensures that the public is not exposed to radio frequency energy levels in excess of the Commissions guidelines.

According to KDB 447498 D01 General RF Exposure v05, section 4.3.1

SAR Test Exclusion Thresholds for 100 MHz-6GHz and ≤ 5 mm

Frequency Range		Maximum measured transmitter power frequency(MHz)	SAR Limitation (mW)
Low Frequency(MHz)	High Frequency(MHz)		
2412	2462	2462	10

7.3 Test Result

Product	: Wireless Adapter	Test Mode	: IEEE 802.11b/g/n
Test Item	: RF Exposure	Temperature	: 25 °C
Test Voltage	: DC 5V (From Host)	Humidity	: 56%RH
Test Result	: PASS		

RF Exposure Requirements	Compliance with FCC Rules
S=PG/4πR ² Where: S=Power density P=Power input to antenna G=Power gain of the antenna relative to an isotropic radiator R=Distance to the center of radiation of the antenna	Maximum output power at antenna input terminal: 5.90 dBm = 3.52 mW (802.11b, 2462MHz) 4.99 dBm = 3.16 mW (802.11g, 2437MHz) 5.94 dBm = 3.92 mW (802.11n/20MHz, 2412MHz) 4.65 dBm = 2.92 mW (802.11n/40MHz, 2452MHz) Prediction distance: ≤ 5 mm Antenna gain : 2.0 dBi SAR Test Exclusion Threshold is 10 mW (802.11b, 2462MHz):8.71 mW (802.11g, 2437MHz):7.06 mW (802.11n/20MHz, 2412MHz):8.78 mW (802.11n/40MHz, 2452MHz):6.54 mW The max. output power E.I.R.P < 10 mW Conclusion: No SAR is required.

8. Photos of Testing

8.1 EUT Test Photographs

Radiated Emission test view

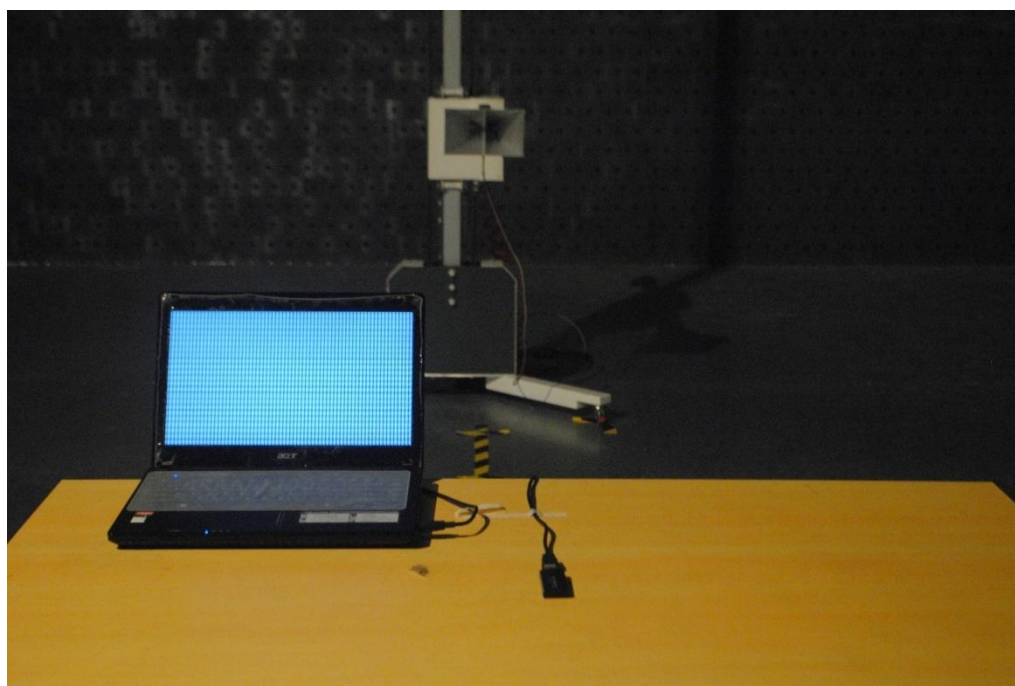
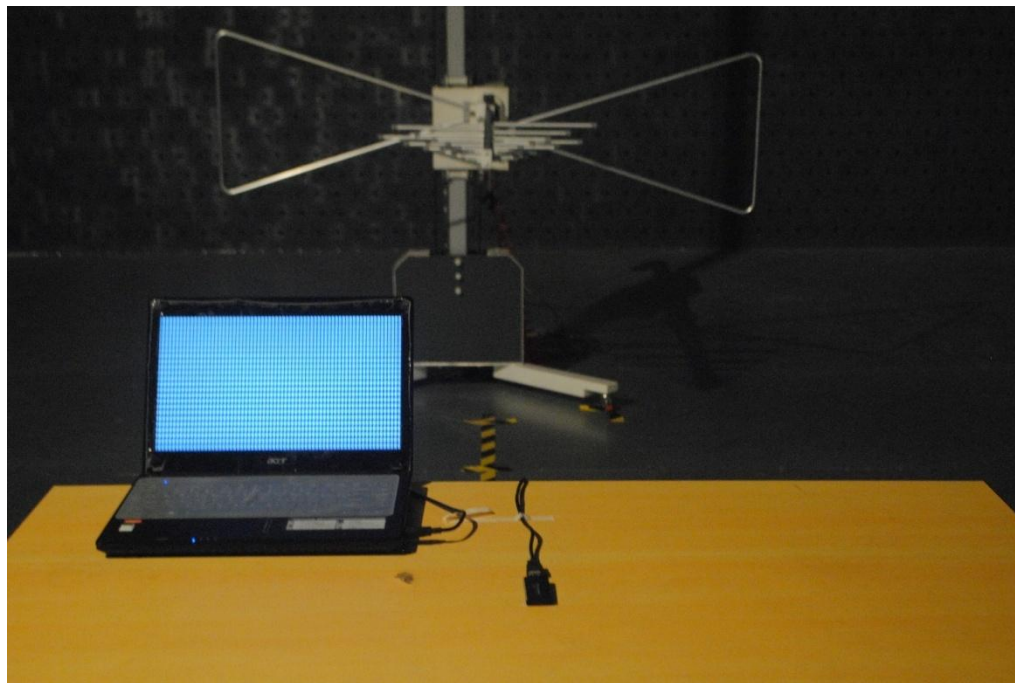

Conducted Emission test view



8. 2 EUT Detailed Photographs

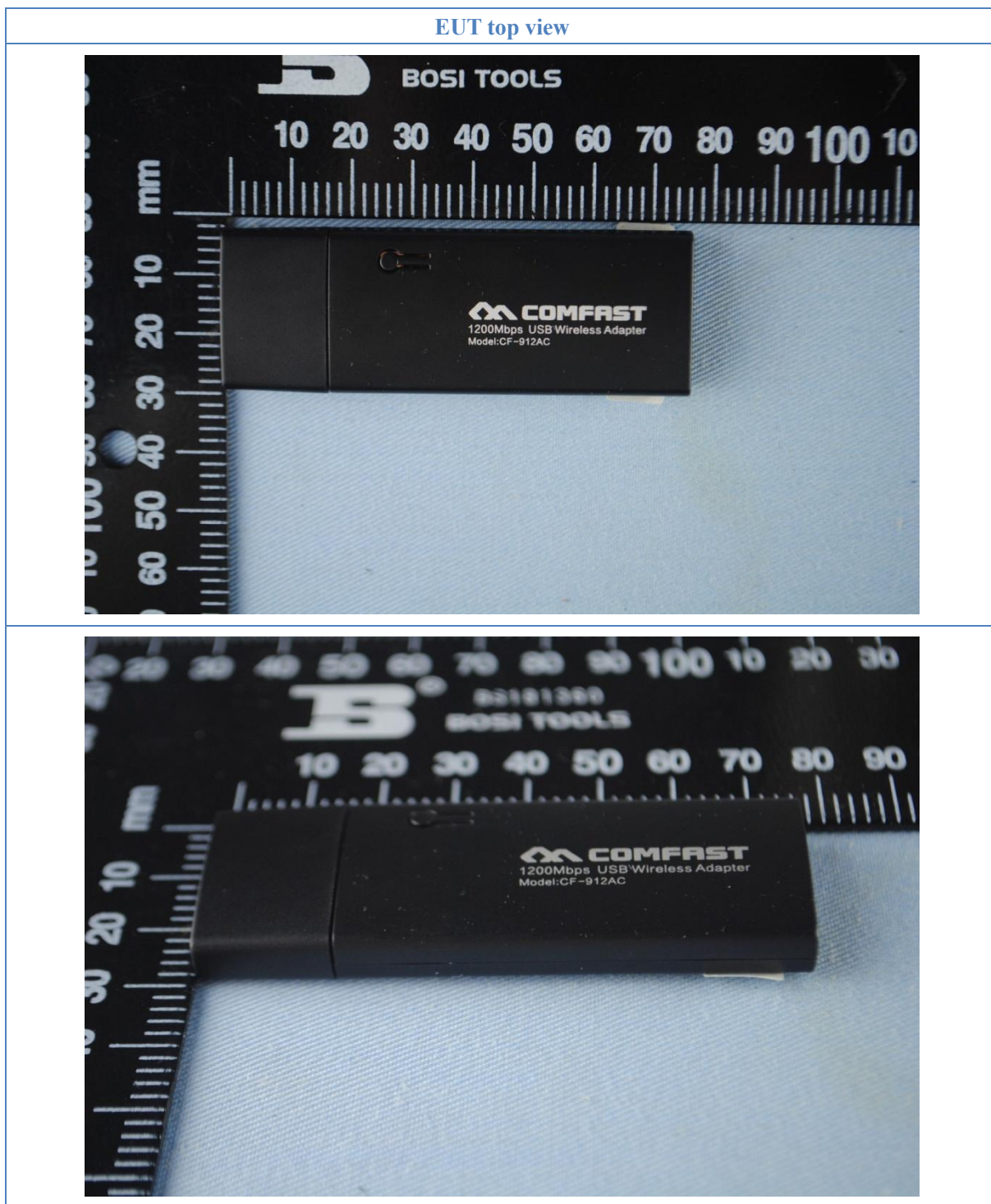

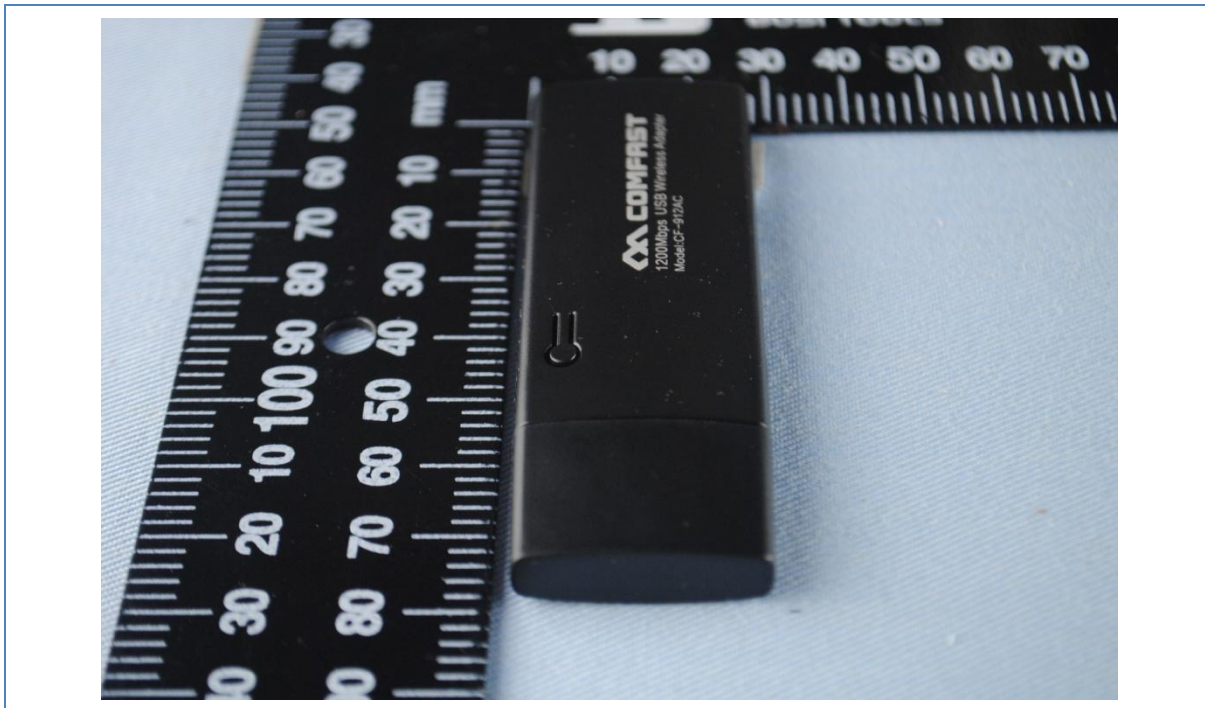

EUT bottom view

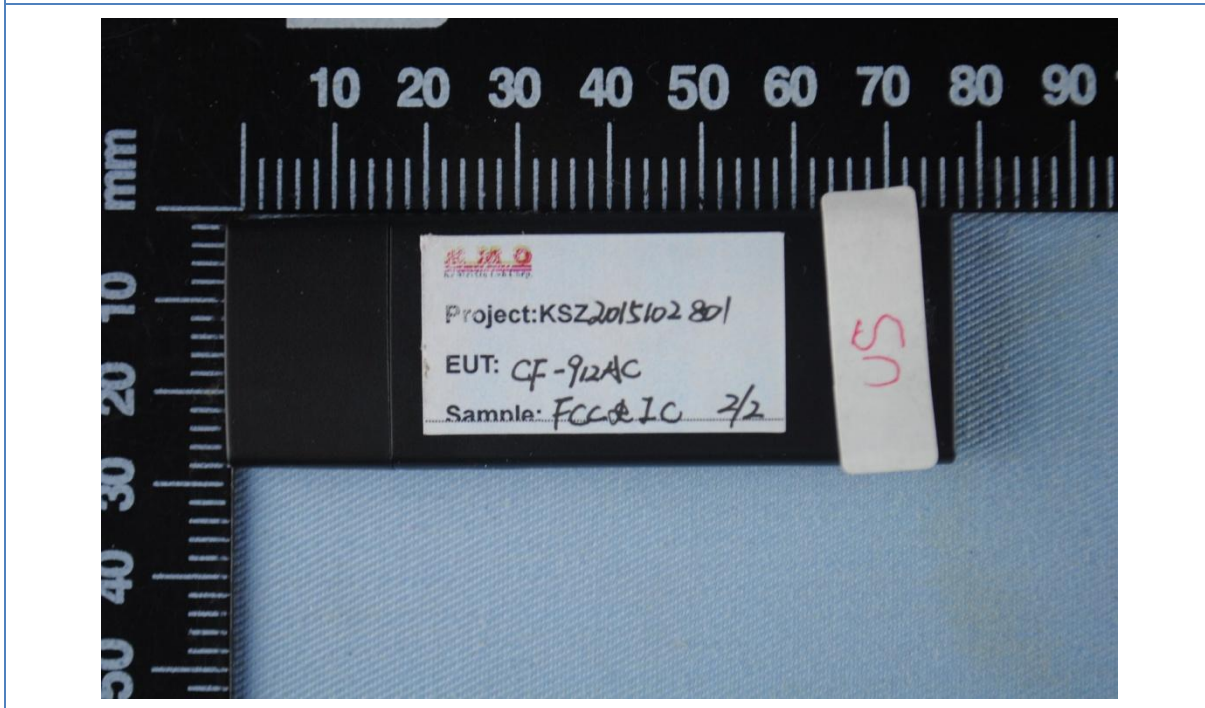

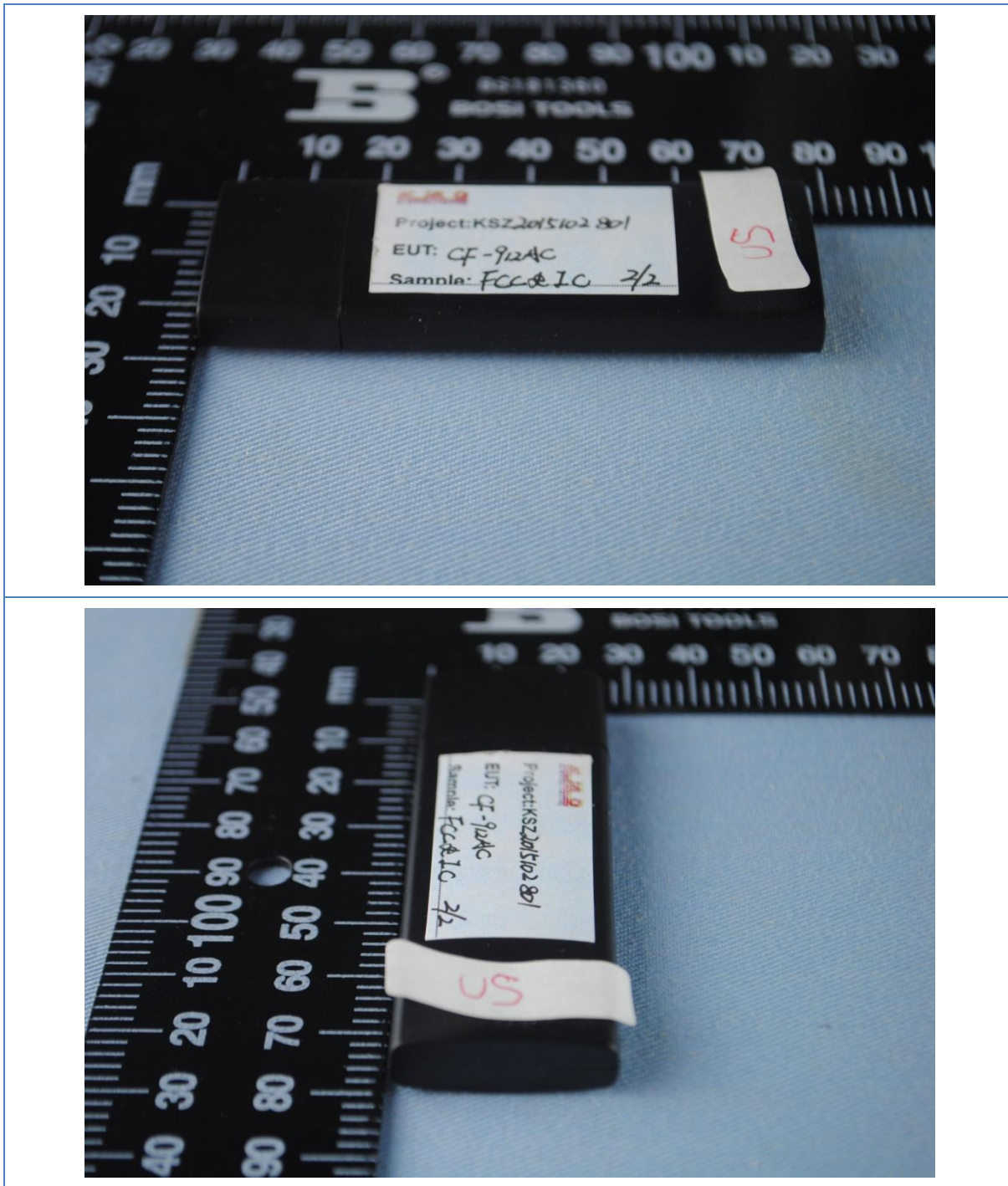

EUT inside whole view

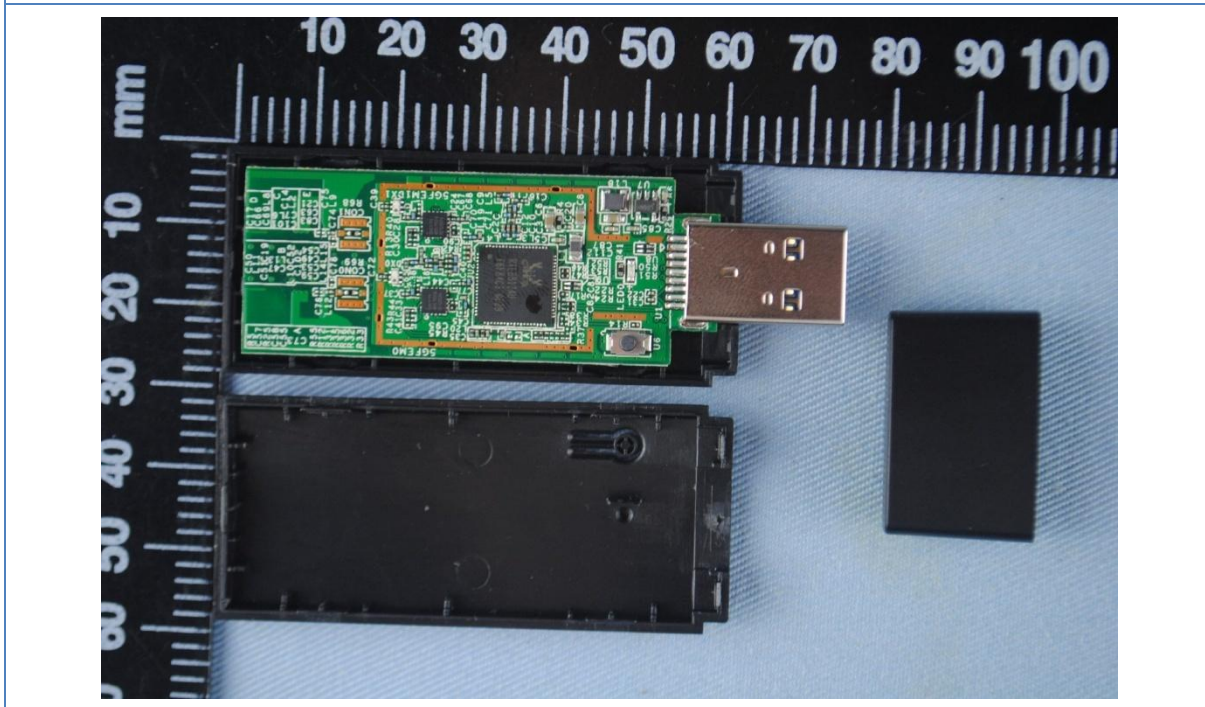

Main board component side

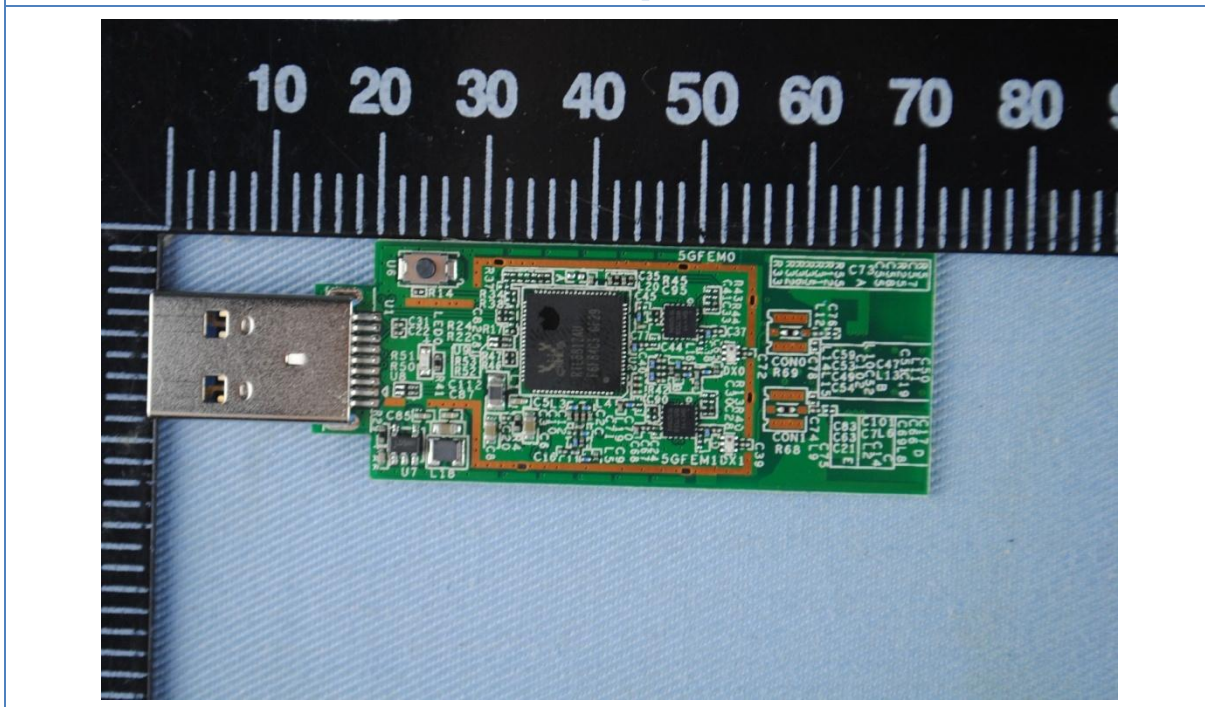

Main board solder side

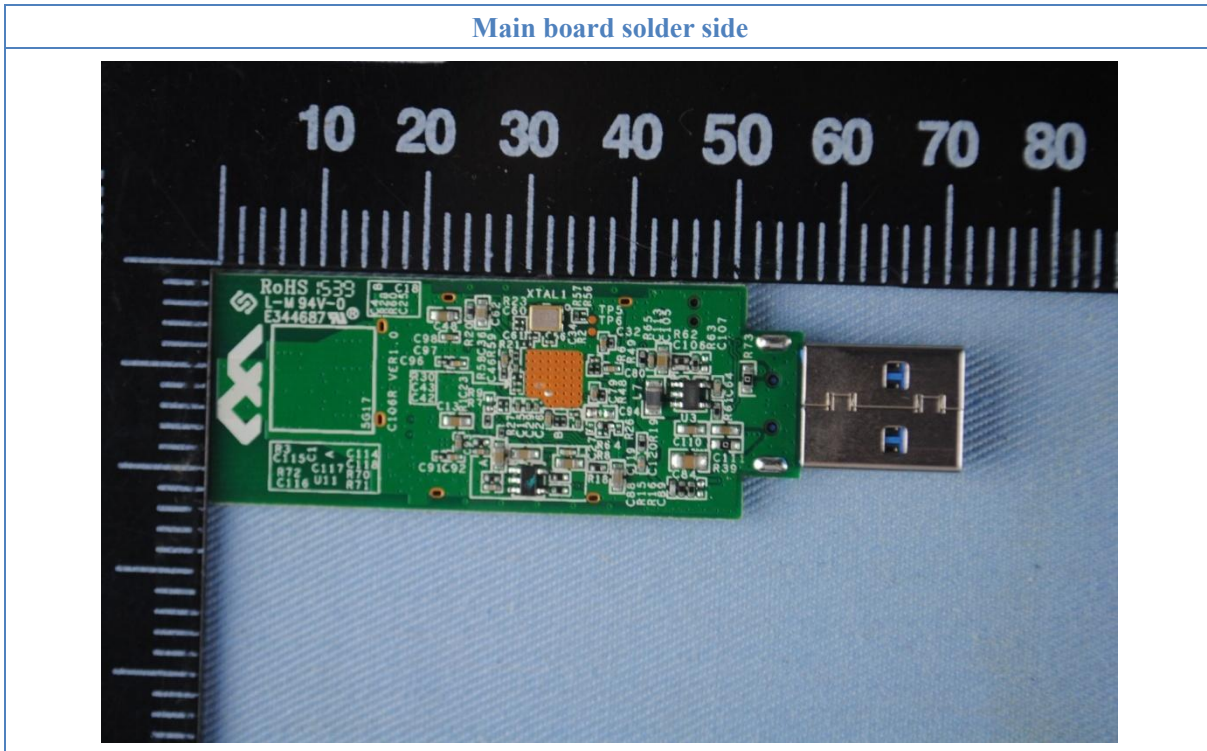

9. FCC ID Label

FCC ID: OYRCF-912AC

This device complies with Part 15 of the FCC Rules. Operation is subject to the following two conditions: (1) this device may not cause harmful interference, and (2) this device must accept any interference received, including interference that may cause undesired operation.

The Label must not be a stick-on paper label. The Label on these products must be permanently affixed to the product and readily visible at the time of purchase and must last the expected lifetime of the equipment not be readily detachable.

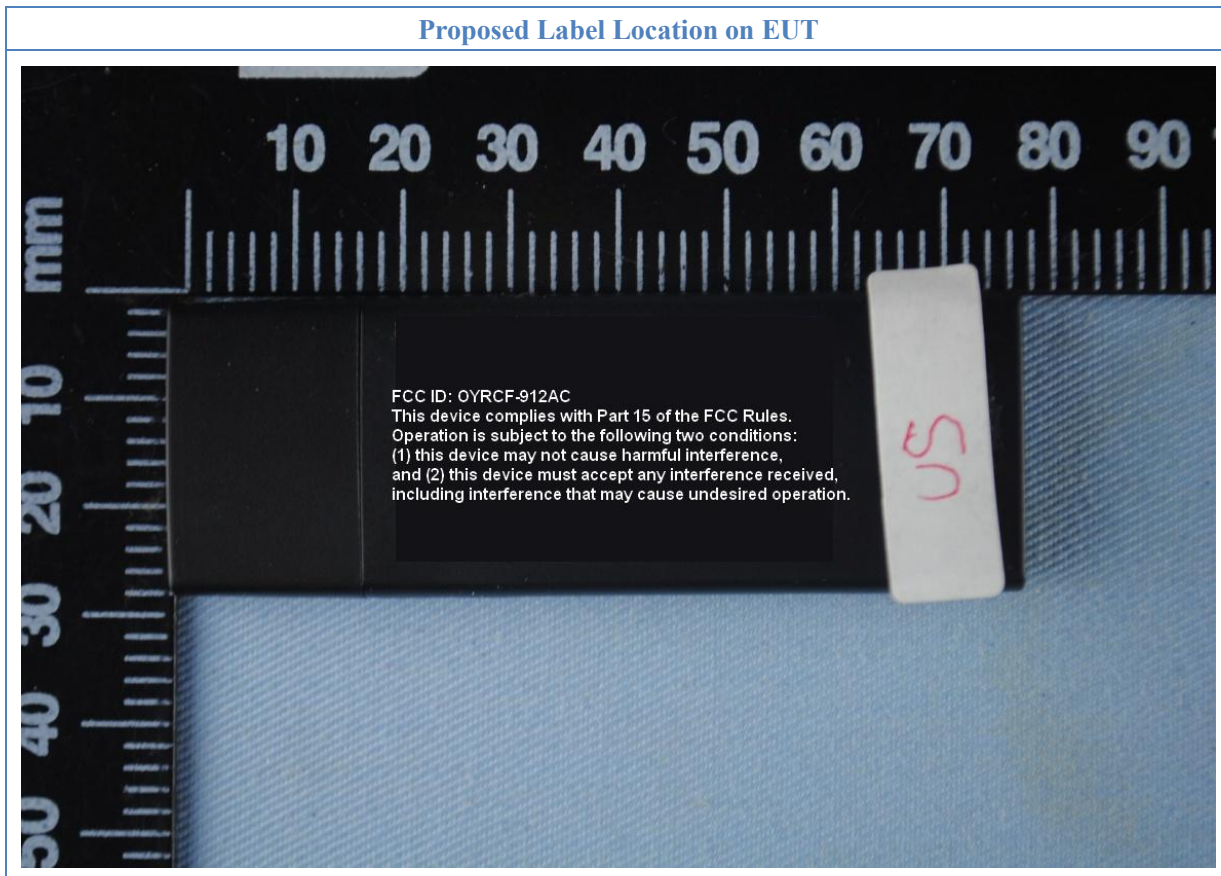

10. Test Equipment

The following test equipments were used during the radiated & conducted emission test:

Equipment/ Facilities	Manufacturer	Model #	Serial No.	Due Date
Turntable	Innco systems GmbH	CT-0801	KMO-SZ114	NCR
Antenna Tower	Innco systems GmbH	MM4000-PP	KMO-SZ115	NCR
Controller	Innco systems GmbH	CO2000	KMO-SZ116	NCR
Pre-Amplifier	Agilent	87405C	KMO-SZ155	Dec.6, 2016
Pre-Amplifier	Com-Power	PAM-840	KMO-SZ156	Dec.6, 2016
Horn Antenna	Com-Power	AH-840	KMO-SZ157	Dec.6, 2016
EMI Test Receiver	Rohde & Schwarz	ESP17	KMO-SZ002	June 27, 2016
Spectrum Analyzer	Rohde & Schwarz	FSP40	KMO-SZ003	June 27, 2016
Signal Generator	FLUKE	PM5418+Y/C	KMO-SZ020	May 27, 2016
Loop Antenna	Rohde & Schwarz	HFH2-Z2	KMO-SZ004	August 19, 2018
Trilog-Super Broadband Antenna	SCHWARZBECK	VULB9161	KMO-SZ005	August 27, 2018
Trilog-Super Broadband Antenna	SCHWARZBECK	VULB9161	KMO-SZ006	August 19, 2018
Broad-Band Horn Antenna	SCHWARZBECK	BBHA 9120D	KMO-SZ007	August 19, 2018
Broad-Band Horn Antenna	SCHWARZBECK	BBHA 9120D	KMO-SZ008	August 19, 2018
AMN	Rohde & Schwarz	ESH3-Z5	KMO-SZ009	June 27, 2016
Pulse Limiter	SCHWARZBECK	VTSD 9561-F	KMO-SZ077	Nov.29, 2016
ISN	SCHWARZBECK	NTFM 8158 CAT3	KMO-SZ070	Nov.19, 2016
ISN	SCHWARZBECK	NTFM 8158 CAT5	KMO-SZ071	Nov.19, 2016
ISN	SCHWARZBECK	NTFM 8158 CAT6	KMO-SZ072	Nov.19, 2016
KMO Shielded Room	KMO	KMO-001	KMO-SZ036	NCR
Coaxial Cable with N-Connectors	SCHWARZBECK	AK9515H	KMO-SZ037	Sep.18, 2016
AC Power Source / Analyzer	Agilent	6813B	KMO-SZ166	July 22, 2016
Power Meter	Rohde & Schwarz	OSP-B157	KMO-HK015	Nov.6, 2016
Digital Radio Communication Tester	Rohde & Schwarz	CMD60	KMO-SZ169	April 10, 2016
Universal Radio Communication Tester	Rohde & Schwarz	CMU200	KMO-SZ170	April 10, 2016
Regulatory Test System 30 MHz to 40 GHz	Rohde & Schwarz	TS8997	KMO-HK015	Nov.6, 2016
Program Control Telephone Exchanger	Excelltel	CDX8000-M	KMO-SZ221	NCR
3m Anechoic Chamber	KMO	KMO-3AC	KMO-3AC-1	Nov.12, 2016
Temperature Chamber	TABAI	PSL-4GTW	N/A	Feb.10, 2016