

6. Application Circuit

Typical Application

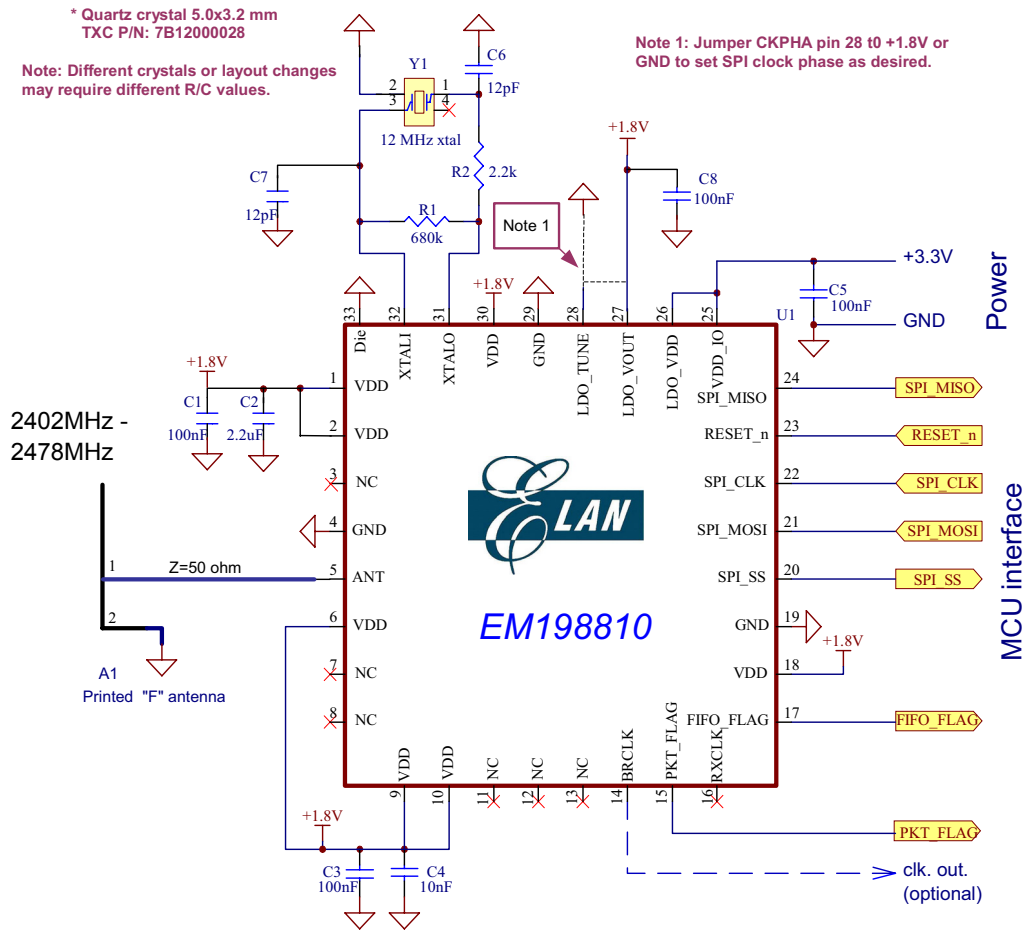

Simple, low-power (0dBm) 2.4GHz RF Transceiver with Framing and Data buffers

- Figure 6 -

BOM list

Comment	Description	Designator	Quantity	Footprint
10pF	Capacitor	C8	1	SMD-0603
12pF	Capacitor	C9	1	SMD-0603
10nF	Capacitor	C6	1	SMD-0603
100nF	Capacitor	C1 C3 C5 C7	4	SMD-0603
2.2uF	Capacitor	C2	1	SMD-0603
0 ohm	Resistor	R4	1	SMD-0603
2.2k	Resistor	R2	1	SMD-0603
680k	Resistor	R1	1	SMD-0603
12MHz	Crystal	Y1	1	OSC 5x3.2
EM198810	IC	U1	1	QFN 32 5x5
CON1x14	Connector	P1	1	HDR1x14

- Table 7 -