

FCC TEST REPORT  
FOR  
Dongguan Taide Industrial Co., Ltd.  
Wireless Webcam  
Model No.: C-151(CyberTrack-V10)

Prepared for : Dongguan Taide Industrial Co., Ltd.  
Address : Taide Industrial Park, Phase 2 Jinfenghuang Industrial,  
Fengguang Town, Dongguan, China

Prepared by : Shenzhen LCS Compliance Testing Laboratory Ltd.  
Address : 1F., Xingyuan Industrial Park, Tongda Road, Bao'an Blvd., Bao'an  
District, Shenzhen, Guangdong, China

Date of receipt of test sample : November 07, 2012  
Number of tested samples : 1  
Serial number : Prototype  
Date of Test : November 07, 2012 - November 30, 2012  
Date of Report : November 30, 2012

FCC TEST REPORT

FCC CFR 47 PART 15 C(15.249)

Report Reference No. .... : LCS121107031QF

Date of issue ..... : November 30, 2012

Testing Laboratory Name..... : Shenzhen LCS Compliance Testing Laboratory Ltd.

Address ..... : 1F., Xingyuan Industrial Park, Tongda Road, Bao'an Blvd., Bao'an District, Shenzhen, Guangdong, China

Testing location/ procedure ..... : Full application of Harmonised standards [checked]
Partial application of Harmonised standards [unchecked]
Other standard testing method [unchecked]

Applicant's name ..... : Dongguan Taide Industrial Co., Ltd.

Address ..... : Taide Industrial Park, Phase 2 Jinfenghuang Industrial, Fengguang Town, Dongguan, China

Test specification

Standard ..... : FCC CFR 47 PART 15 Subpart C: 2011; ANSI C63.4-2009;

Test Report Form No..... : LCSEMC-1.0

TRF Originator ..... : Shenzhen LCS Compliance Testing Laboratory Ltd.

Master TRF ..... : Dated 2011-03

SHENZHEN LCS COMPLIANCE TESTING LABORATORY LTD. All rights reserved.

This publication may be reproduced in whole or in part for non-commercial purposes as long as the Shenzhen LCS Compliance Testing Laboratory Ltd. is acknowledged as copyright owner and source of the material. Shenzhen LCS Compliance Testing Laboratory Ltd. takes no responsibility for and will not assume liability for damages resulting from the reader's interpretation of the reproduced material due to its placement and context.

Test item description. .... : Wireless Webcam

Trade Mark ..... : [TAIDE logo]

Model/Type reference..... : C-151(CyberTrack-V10)

Ratings ..... : DC 3.7V

Result ..... : Positive

Compiled by:

[Signature of Ada Liang]

Ada Liang/ File administrators

Supervised by:

[Signature of Vito Cao]

Vito Cao/ Technique principal

Approved by:

[Signature of Gavin Liang]

Gavin Liang/ Manager

# FCC --TEST REPORT

<b>Test Report No. : LCS121107031QF</b>	<u>November 30, 2012</u> Date of issue
---	---

Type / Model..... : C-151(CyberTrack-V10)  EUT..... : Wireless Webcam
<b>Applicant..... : Dongguan Taide Industrial Co., Ltd.</b> Address..... : Taide Industrial Park, Phase 2 Jinfenghuang Industrial, Fengguang Town, Dongguan, China Telephone..... : / Fax..... : /
<b>Manufacturer..... : DONGGUAN TAIDE INDUSTRIAL CORPORATION LTD</b> Address..... : Taide Industrial Park, Phase 2 Jinfenghuang Industrial, Fengguang Town, Dongguan, China Telephone..... : / Fax..... : /
<b>Factory..... : DONGGUAN TAIDE INDUSTRIAL CORPORATION LTD</b> Address..... : Taide Industrial Park, Phase 2 Jinfenghuang Industrial, Fengguang Town, Dongguan, China Telephone..... : / Fax..... : /

<b>Test Result:</b>	<b>Positive</b>
---------------------	-----------------

The test report merely corresponds to the test sample.  
 It is not permitted to copy extracts of these test result without the written permission of the test laboratory.

## TABLE OF CONTENTS

Description	Page
<b>1. GENERAL INFORMATION .....</b>	<b>5</b>
1.1. Description of Device (EUT).....	5
1.2. Description of Test Facility .....	5
1.3. Statement of the measurement uncertainty .....	5
1.4. Measurement Uncertainty.....	5
<b>2. TEST METHODOLOGY .....</b>	<b>6</b>
2.1. EUT Configuration .....	6
2.2. EUT Exercise.....	6
2.3. General Test Procedures .....	6
2.4. Description Of Test Modes.....	6
<b>3. SUMMARY OF TEST RESULTS .....</b>	<b>7</b>
<b>4. BANDWIDTH OF THE EMISSION .....</b>	<b>8</b>
4.1. Standard Applicable.....	8
4.2. Test Equipment.....	8
4.3. Test Procedure .....	8
4.4. Test Results.....	9
<b>5. RESTRICTED BANDS OF OPERATION .....</b>	<b>11</b>
5.1. Standard Applicable.....	11
5.2 Test Equipment.....	11
5.3 Block Diagram of Test Setup.....	11
5.4 Test Procedure .....	11
5.4. Test Results.....	12
<b>6. RADIATED EMISSIONS (TRANSMITTER) .....</b>	<b>13</b>
6.1. Standard Applicable.....	13
6.2. Test Equipment List and Details.....	13
6.3. Measuring Instruments and Setting .....	14
6.4. Test Procedures.....	14
6.5. Test Setup .....	16
6.6. Test Data.....	17
<b>7. POWER LINE CONDUCTED EMISSIONS.....</b>	<b>25</b>
7.1 Standard Applicable.....	25
7.2 Test Equipment.....	25
7.3 Block Diagram of Test Setup.....	25
7.4 Test Data.....	25
<b>8. ANTENNA REQUIREMENT .....</b>	<b>27</b>
8.1 Standard Applicable.....	27
<b>9. MANUFACTURER/ APPROVAL HOLDER DECLARATION .....</b>	<b>28</b>

## 1. GENERAL INFORMATION

### 1.1. Description of Device (EUT)

EUT	: Wireless Webcam
Model Number	: C-151(CyberTrack-V10)
Power Supply	: DC 3.7V
Frequency Range	: 2403.00-2480.00MHz (Channel Number: 78, Channel Frequency=2403+1(K-1)MHz, K=1, 2, 3 .....78)
Modulation Type	: FSK
Antenna Gain	: 1.8dBi

### 1.2. Description of Test Facility

Site Description	
EMC Lab.	: Accredited by CNAS, June 04, 2010 The Certificate Registration Number. is L4595. Accredited by FCC, July 14, 2011 The Certificate Registration Number. is 899208. Accredited by Industry Canada, May. 02, 2011 The Certificate Registration Number. is 9642A-1

### 1.3. Statement of the measurement uncertainty

The data and results referenced in this document are true and accurate. The reader is cautioned that there may be errors within the calibration limits of the equipment and facilities. The measurement uncertainty was calculated for all measurements listed in this test report acc. To CISPR 16 – 4 “Specification for radio disturbance and immunity measuring apparatus and methods – Part 4: Uncertainty in EMC Measurements” and is documented in the LCS quality system acc. To DIN EN ISO/IEC 17025. Furthermore, component and process variability of devices similar to that tested may result in additional deviation. The manufacturer has the sole responsibility of continued compliance of the device.

### 1.4. Measurement Uncertainty

Test Item	Frequency Range	Uncertainty	Note
Radiation Uncertainty	30MHz~200MHz	± 2.96dB	(1)
	200MHz~1000MHz	± 3.10dB	(1)
	1GHz~26.5GHz	± 3.90dB	(1)
Conduction Uncertainty	150kHz~30MHz	± 1.63dB	(1)
Power disturbance	30MHz~300MHz	± 1.60dB	(1)

1). This uncertainty represents an expanded uncertainty expressed at approximately the 95% confidence level using a coverage factor of k=2.

## 2. TEST METHODOLOGY

All measurements contained in this report were conducted with ANSI C63.4-2009, American National Standard for Methods of Measurement of Radio-Noise Emissions from Low-Voltage Electrical and Electronic Equipment in the range of 9 kHz to 40 GHz.

The radiated testing was performed at an antenna-to-EUT distance of 3 meters. All radiated and conducted emissions measurement was performed at Shenzhen LCS Compliance Testing Laboratory Ltd..

### 2.1. EUT Configuration

The EUT configuration for testing is installed on RF field strength measurement to meet the Commissions requirement and operating in a manner that intends to maximize its emission characteristics in a continuous normal application.

### 2.2. EUT Exercise

The EUT was operated in the engineering mode to fix the TX frequency that was for the purpose of the measurements.

According to its specifications, the EUT must comply with the requirements of the Section 15.203, 15.205, 15.207, 15.209 , 15.249 under the FCC Rules Part 15 Subpart C; ANSI C63.4-2009.

### 2.3. General Test Procedures

#### 2.3.1 Conducted Emissions

The EUT is placed on the turntable, which is 0.8 m above ground plane. According to the requirements in Section 13.1.4.1 of ANSI C63.4 Conducted emissions from the EUT measured in the frequency range between 0.15 MHz and 30MHz using Quasi-peak and average detector modes.

#### 2.3.2 Radiated Emissions

The EUT is placed on a turn table, which is 0.8 m above ground plane. The turntable shall rotate 360 degrees to determine the position of maximum emission level. EUT is set 3m away from the receiving antenna, which varied from 1m to 4m to find out the highest emission. And also, each emission was to be maximized by changing the polarization of receiving antenna both horizontal and vertical. In order to find out the maximum emissions, exploratory radiated emission measurements were made according to the requirements in Section 13.1.4.1 of ANSI C63.4

### 2.4. Description Of Test Modes

The EUT was set to continuous transmitting mode.

FSK modulation 2.4GHz mode the worst case is Channel Low (2403MHz), Mid Channel (2442MHz) and High Channel (2480MHz), these were chosen for full testing.

### 3. SUMMARY OF TEST RESULTS

FCC CFR 47 Part 15	DESCRIPTION OF TEST	RESULT
§15.203	Antenna requirement	Compliant
§15.215(c)	Bandwidth of the emission	Compliant
§15.207(a)	Conduction Emissions	Compliant
§15.205(a)	Restricted bands of operation	Compliant
§15.205(b), §15.249	Radiated emission 9kHz to 30 MHz	Compliant
§15.205(b), §15.215(b), §15.249	Radiated emission 30 MHz to 40 GHz	Compliant

*N/A is not applicable.*

## 4. BANDWIDTH OF THE EMISSION

### 4.1. Standard Applicable

The 20 dB bandwidth of the emission is measured as the frequency range defined by the points that are 20 dB down relative to the maximum level of the modulated carrier.

For intentional radiators operating under the alternative provisions to the general emission limits the requirement to contain the 20 dB bandwidth of the emission within the specified frequency band includes the effects from frequency sweeping, frequency hopping and other modulation techniques that may be employed as well as the frequency stability of the transmitter over expected variations in temperature and supply voltage. If a frequency stability is not specified in the regulations, it is recommended that the fundamental emission be kept within at least the central 80% of the permitted band in order to minimize the possibility of out-of-band operation.

The resolution bandwidth of the spectrum analyzer shall be set to a value greater than 5.0% of the allowed bandwidth. If no bandwidth specifications are given, the following guidelines are used:

Fundamental frequency	Minimum resolution bandwidth
9kHz to 30MHz	1kHz
30MHz to 1000MHz	10kHz
1000MHz to 40GHz	100kHz

### 4.2. Test Equipment

Item	Equipment	Manufacturer	Model No.	Serial No.	Cal. Data	Due Data
1	Test Receiver	Rohde & Schwarz	ESCS30	828985/018	2012-06-18	2013-06-17
2	DC Filter	MPE	23872C	N/A	2012-06-18	2013-06-17

### 4.3. Test Procedure

If antenna is detachable bandwidth measurements shall be performed at the antenna connector (conducted measurement) when the transmitter is adjusted in accordance with the tune-up procedure, if applicable. The RF output terminals are connected to a spectrum analyzer. If required, a resistive matching network equal to the impedance specified or employed for the antenna is used as well as dc block and appropriate attenuators (50 Ohms). The electrical characteristics of the radio frequency load attached to the output terminals shall be stated, if applicable.

If radiated measurements are performed the same test setups and instruments are used as with radiated emission measurements for the appropriate frequency range.

The analyzer settings are specified by the test description of the appropriate test record(s).



### 4.4. Test Results

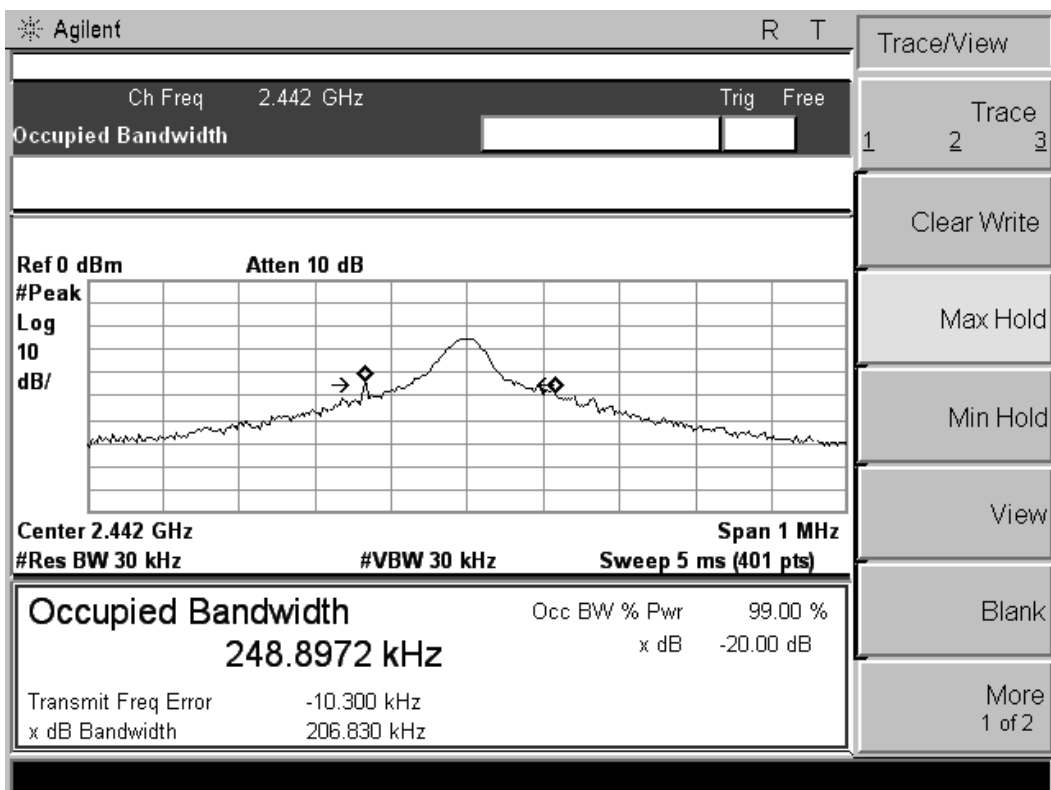
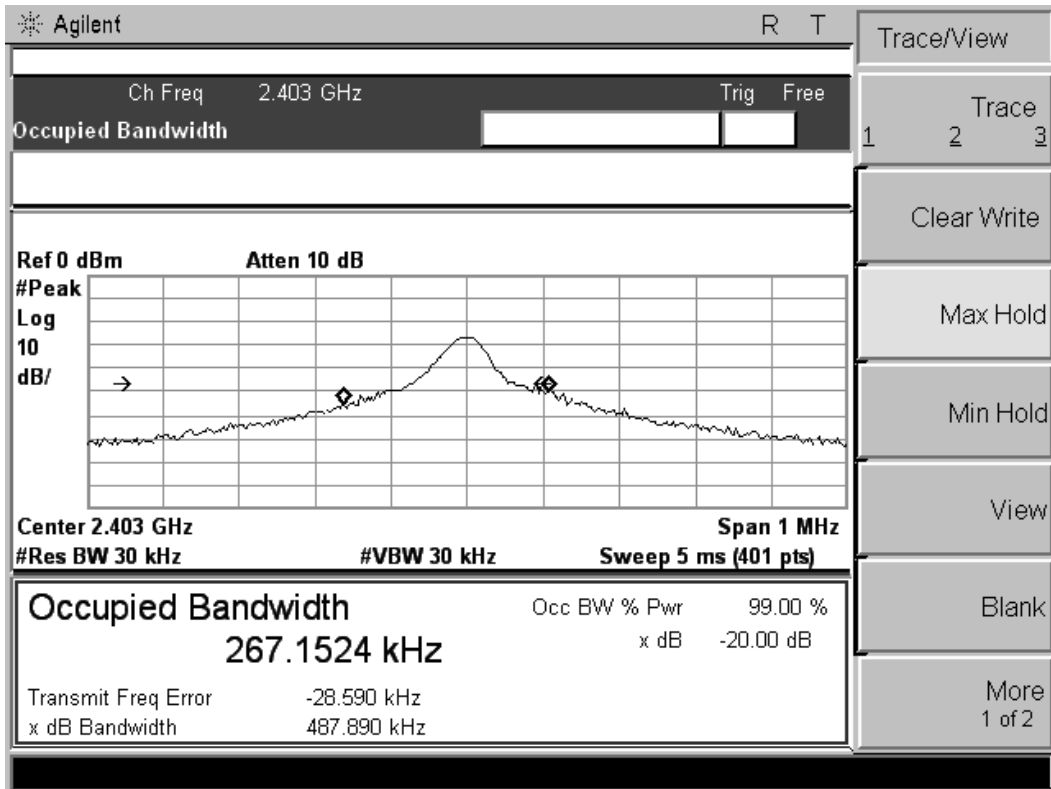

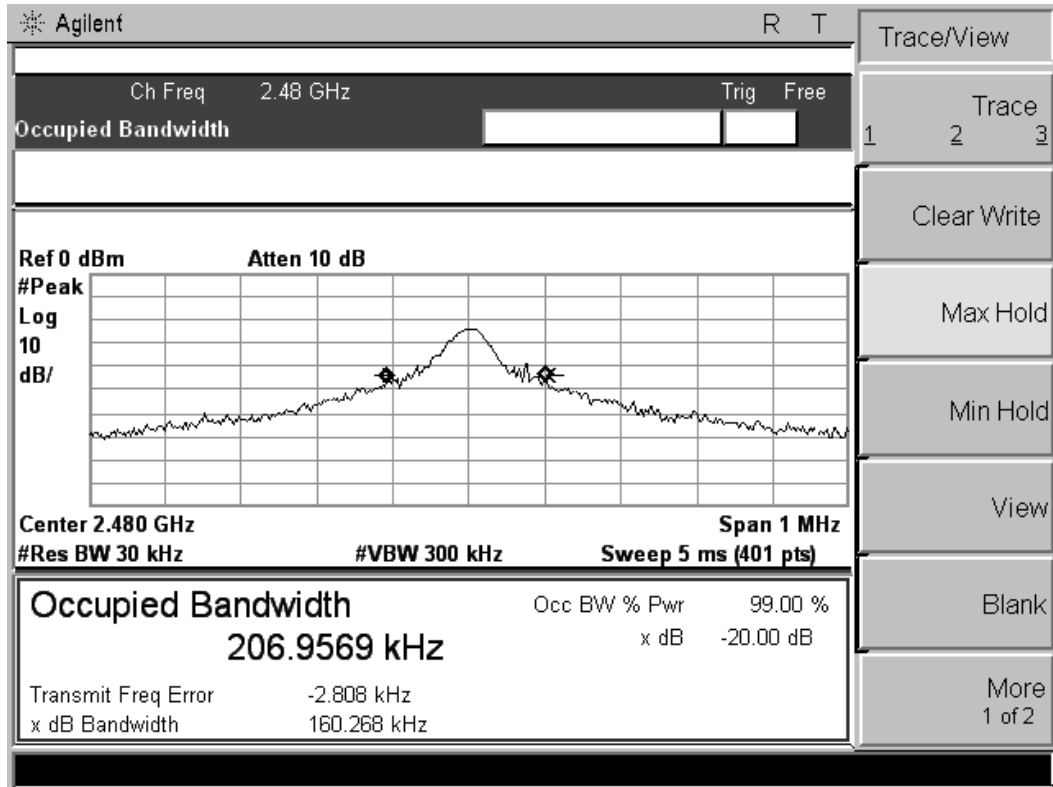

## 5. RESTRICTED BANDS OF OPERATION

### 5.1. Standard Applicable

Emissions radiated outside of the specified frequency bands, except for harmonics, shall be attenuated by at least 50 dB below the level of the fundamental or to the general radiated emission limits in §15.209, whichever is the lesser attenuation.

bandwidth within the band that contains the highest level of the desired power, In addition, radiated emissions which fall in the restricted bands, as defined in §15.205(a), must also comply with the radiated emission limits specified in §15.209(a).

### 5.2 Test Equipment

Item	Equipment	Manufacturer	Model No.	Serial No.	Last Cal.	Next Cal.
1	Spectrum Analyzer	Agilent	E4407B	MY41440292	2012-06-18	2013-06-17
2	RF Cable	Hubersuhne	Sucoflex104	FP2RX2	2012-06-18	2013-06-17
3	DC Filter	MPE	23872C	N/A	2012-06-18	2013-06-17

### 5.3 Block Diagram of Test Setup

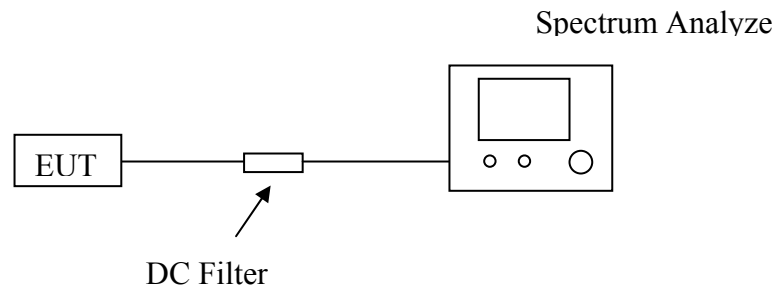

### 5.4 Test Procedure

- Place the EUT on the table and set it in transmitting mode.
- Remove the antenna from the EUT and then connect a low loss RF cable from the antenna port to the Spectrum Analyzer.
- Set center frequency of Spectrum Analyzer = Lower and Upper channel.
- Set the Spectrum Analyzer as RBW = 100kHz, VBW = 300kHz, Span = 10MHz, Sweep = auto.
- Max hold, mark 1 peak of hopping channel and record the 1 peaks frequency.

### 5.4. Test Results

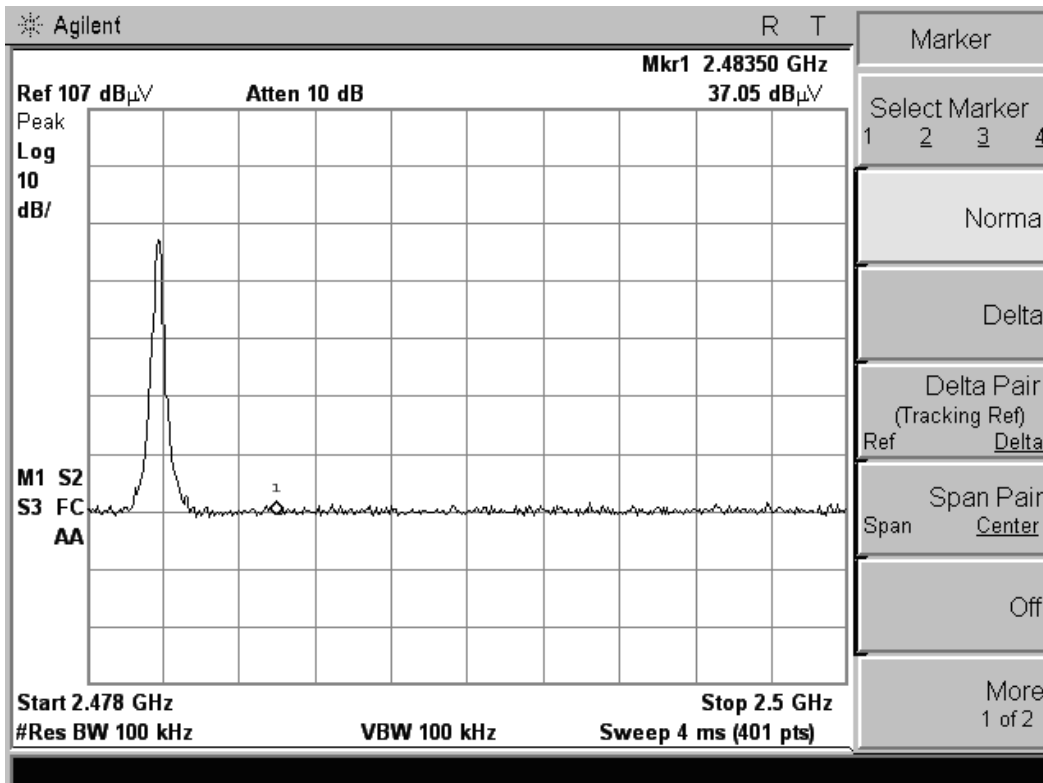
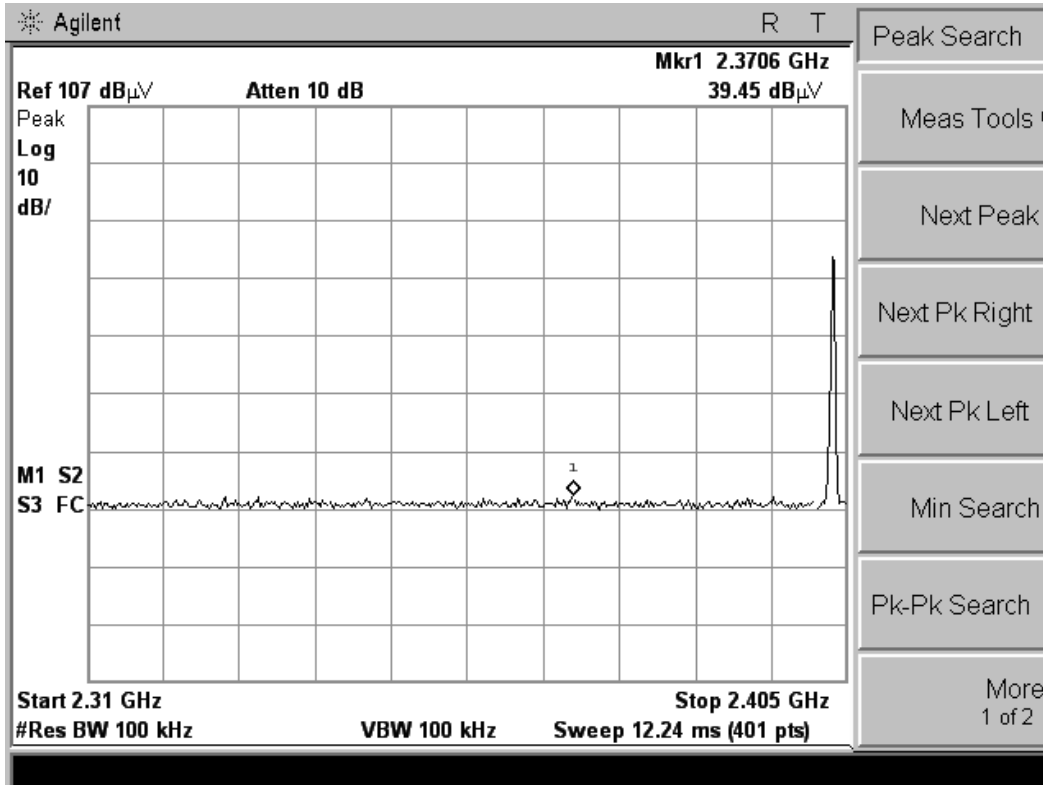

## 6. RADIATED EMISSIONS (TRANSMITTER)

### 6.1. Standard Applicable

Emissions radiated outside of the specified frequency bands, except for harmonics, shall be attenuated by at least 50 dB below the level of the fundamental or to the general radiated emission limits in §15.209, whichever is the lesser attenuation.

20dBc in any 100 kHz bandwidth outside the operating frequency band. In case the emission fall within the restricted band specified on 15.205(a), then the 15.209(a), IC RSS-210 Issue 7, section A2.9(b) and 15.249 limit in the table below has to be followed.

Fundamental Frequency	Field Strength of fundamental (millivolts/meter)	Field Strength of harmonics (micorvolts/meter)
902-928MHz	50	500
2400-2483.5MHz	50	500
5725-5875MHz	50	500
24.0-24.25GHz	250	2500

Frequencies (MHz)	Field Strength (micorvolts/meter)	Measurement Distance (meters)
0.009~0.490	2400/F(KHz)	300
0.490~1.705	24000/F(KHz)	30
1.705~30.0	30	30
30~88	100	3
88~216	150	3
216~960	200	3
Above 960	500	3

### 6.2. Test Equipment List and Details

Item	Equipment	Manufacturer	Model No.	Serial No.	Cal. Data	Due Data
1	Spectrum Analyzer	Agilent	E4407B	MY41440292	2012-06-18	2013-06-17
2	Test Receiver	Rohde & Schwarz	ESCS30	828985/018	2012-06-18	2013-06-17
3	Loop antenna	EMCO	6502	0042963	2012-06-18	2013-06-17
4	Log per Antenna	Schwarzbeck	VULB9163	142	2012-06-18	2013-06-17
5	Horn-antenna	SCHWARZBECK	BBHA9120D	D:266	2012-06-18	2013-06-17
6	DC Filter	MPE	23872C	N/A	2012-06-18	2013-06-17

### 6.3. Measuring Instruments and Setting

The following table is the setting of spectrum analyzer and receiver.

Spectrum Parameter	Setting
Attenuation	Auto
Start ~ Stop Frequency	9kHz~150kHz/RB 200Hz for QP
Start ~ Stop Frequency	150kHz~30MHz/RB 9kHz for QP
Start ~ Stop Frequency	30MHz~1000MHz/RB 120kHz for QP

Spectrum Parameter	Setting
Attenuation	Auto
Start Frequency	1000 MHz
Stop Frequency	10th carrier harmonic
RB / VB (Emission in restricted band)	1MHz/1MHz for Peak, 1MHz/10Hz for Average
RB / VB (Emission in non-restricted band)	1000KHz/1000KHz for peak

### 6.4. Test Procedures

Radiated emission in the frequency range 9 kHz to 30 MHz is measured using an active loop antenna. First the whole spectrum of emission caused by the equipment is recorded at a distance of 3 meters in a fully or semi anechoic room with the detector of the spectrum analyzer or EMI receiver set to peak. This configuration is also used for recording the spectrum of intentional radiators.

Hand-held or body-worn devices are rotated through three orthogonal axes to determine which attitude and configuration produces the highest emission relative to the limit and therefore shall be used for final testing.

EUT is rotated all around to find the maximum levels of emissions. Equipment and cables are placed and moved within the range of position likely to find their maximum emissions.

If worst case emission of the EUT cannot be recorded with EUT in standard position and loop antenna in vertical polarization the EUT (or the radiating part of the EUT) is rotated by 90 degrees instead of changing the loop antenna to horizontal polarization. This procedure is selected to minimize the influence of the environment (e.g. effects caused by the floor especially with longer distances).

Final measurement is performed at a test distance D of 30 meters using an open field test site. In case the regulation requires testing at other distances, the result is extrapolated by either making measurements at an additional distance D of 10 meters to determine the proper extrapolation factor or by using the square of an inverse linear distance extrapolation factor (40 dB/decade). In cases of very low emissions measurements are performed at shorter distances and results are extrapolated to the required distance. The provisions of CFR 47 Part 15 sections 15.31(d) and (f)(2) apply. According to CFR 47 Part 15 section 15.209(d) final measurement is performed with detector function set to quasi-peak except for the frequency bands 9 to 90 kHz and 110 to 490 kHz where, for non-pulsed operation, average detector is employed.

If the radiated emission limits are expressed in terms of the average value of the emission there also is a peak limit corresponding to 20 dB above the maximum permitted average limit. Additionally, if pulsed operation is employed, the average field strength is determined by averaging over one complete pulse train, including blanking intervals, as specified in CFR 47 Part 15 section 15.35(c). If the pulse train exceeds 0.1 second that 0.1 second interval during which the value of the emission is at its maximum is selected for calculation. The pulse train correction is added to the peak value of the emission to get the average value.

Radiated emission in fully or semi anechoic room is measured in the frequency range from 30 MHz to the maximum frequency as specified in CFR 47 Part 15 section 15.33.

Measurements are made in both the horizontal and vertical planes of polarization in a fully anechoic room using a spectrum analyzer with the detector function set to peak and resolution as well as video bandwidth set to 100 kHz (below 1 GHz) or 1 MHz (above 1 GHz).

Testing up to 1 GHz is performed with a linear polarized logarithmic periodic antenna combined with a 4:1 broadband dipole ("Trilog broadband antenna"). For testing above 1 GHz horn antennas are used.

All tests below 8.2 GHz are performed at a test distance D of 3 meters. For higher frequencies the test distance may be reduced (e.g. to 1 meter) due to the sensitivity of the measuring instrument(s) and the test results are calculated according to CFR 47 Part 15 section 15.31(f)(1) using an extrapolation factor of 20 dB/decade. If required, preamplifiers are used for the whole frequency range. Special care is taken to avoid overload, using appropriate attenuators and filters, if necessary.

If the radiated emission limits are expressed in terms of the average value of the emission there also is a peak limit corresponding to 20 dB above the maximum permitted average limit. Additionally, if pulsed operation is employed, the average field strength is determined by averaging over one complete pulse train, including blanking intervals, as specified in CFR 47 Part 15 section 15.35(c). If the pulse train exceeds 0.1 second that 0.1 second interval during which the value of the emission is at its maximum is selected for calculation. The pulse train correction is added to the peak value of the emission to get the average value.

Hand-held or body-worn devices are rotated through three orthogonal axes to determine which attitude and configuration produces the highest emission relative to the limit and therefore shall be used for final testing.

During testing the EUT is rotated all around to find the maximum levels of emissions. Equipment and cables are placed and moved within the range of position likely to find their maximum emissions.

For final testing below 1 GHz an open field test-site is used and the plots recorded in the fully or semi anechoic room are indicated as pre-scans.

### 6.5. Test Setup

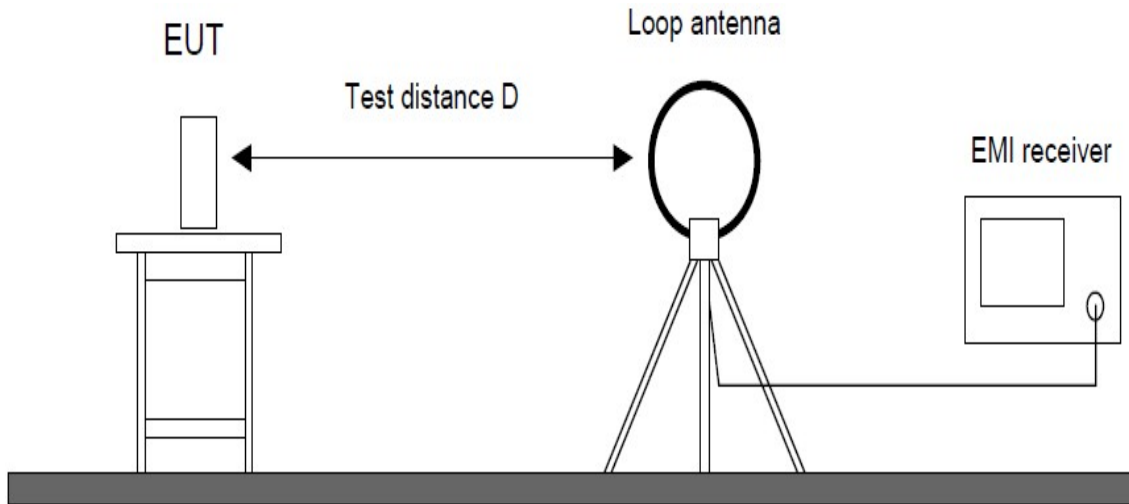

Below 30MHz

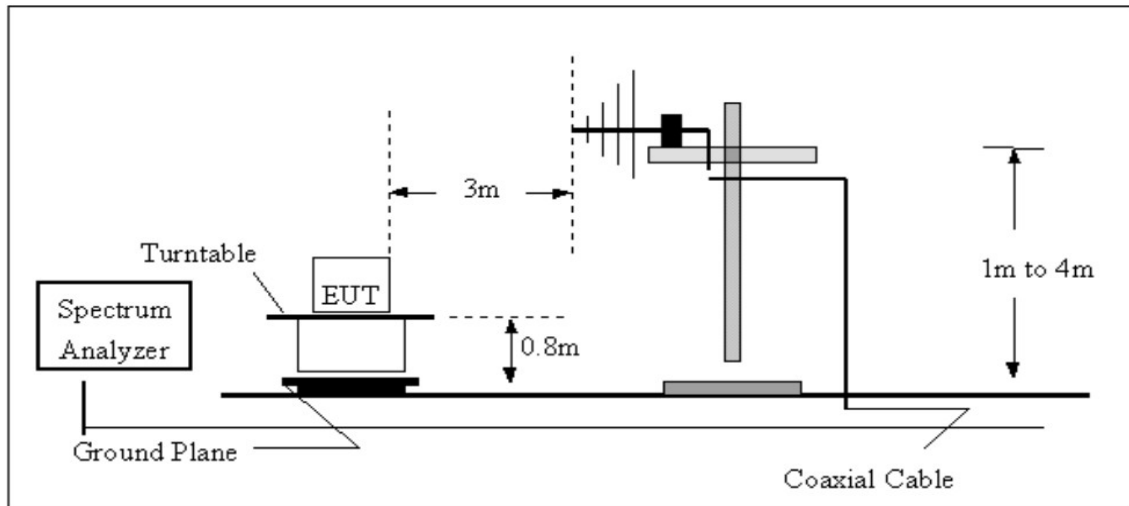

Below 1000MHz

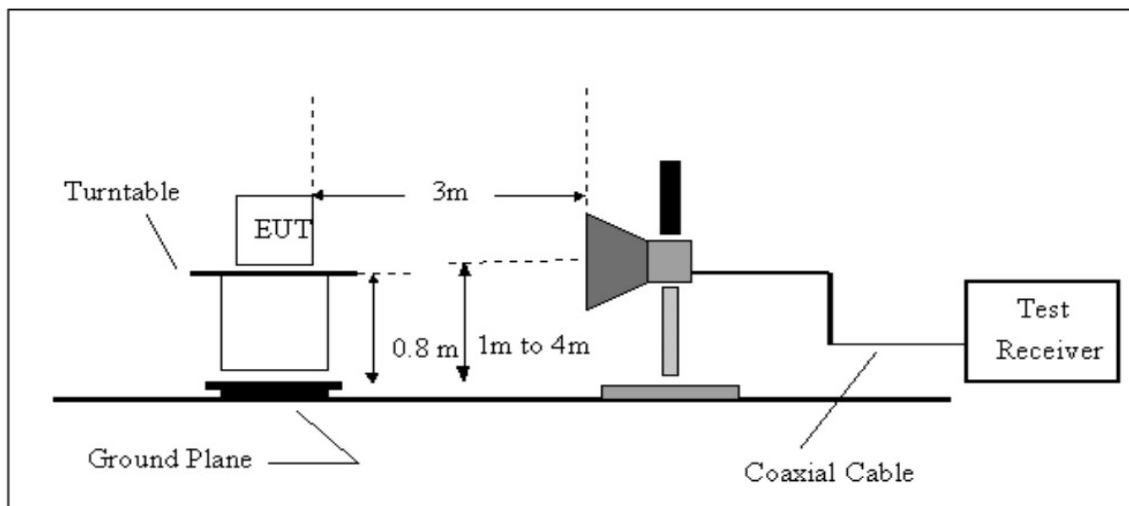

Above 1000MHz



## 6.6. Test Data

### Field Strength of Fundamental Carrier Low Channel

Freq. (MHz)	Level (dBuV/m)	Read Level (dBuV)	Ant. Fac (dB/m)	Pre. Fac (dB)	Cab.Los (dB)	Over limit (dB)	Limits (dBuV/m)	Remark	Pol/Phase
2403.00	87.72	91.83	27.87	35.86	3.88	-26.28	114.00	Peak	Horizontal
2403.00	84.99	89.10	27.87	35.86	3.88	-9.01	94.00	Average	Horizontal
2403.00	93.70	97.81	27.87	35.86	3.88	-20.30	114.00	Peak	Vertical
2403.00	90.00	94.11	27.87	35.86	3.88	-4.00	94.00	Average	Vertical

### Field Strength of Fundamental Carrier Mid Channel

Freq. (MHz)	Level (dBuV/m)	Read Level (dBuV)	Ant. Fac (dB/m)	Pre. Fac (dB)	Cab.Los (dB)	Over limit (dB)	Limits (dBuV/m)	Remark	Pol/Phase
2442.00	86.26	90.36	27.87	35.86	3.89	-27.74	114.00	Peak	Horizontal
2442.00	83.90	88.00	27.87	35.86	3.89	-10.10	94.00	Average	Horizontal
2442.00	92.80	96.90	27.87	35.86	3.89	-21.20	114.00	Peak	Vertical
2442.00	90.29	94.39	27.87	35.86	3.89	-3.71	94.00	Average	Vertical

### Field Strength of Fundamental Carrier High Channel

Freq. (MHz)	Level (dBuV/m)	Read Level (dBuV)	Ant. Fac (dB/m)	Pre. Fac (dB)	Cab.Los (dB)	Over limit (dB)	Limits (dBuV/m)	Remark	Pol/Phase
2480.00	86.42	90.52	27.87	35.86	3.89	-27.58	114.00	Peak	Horizontal
2480.00	83.83	87.93	27.87	35.86	3.89	-10.17	94.00	Average	Horizontal
2480.00	91.60	95.70	27.87	35.86	3.89	-22.40	114.00	Peak	Vertical
2480.00	89.69	93.79	27.87	35.86	3.89	-4.31	94.00	Average	Vertical

Note: 1. Emission level=Read level + Ant. Factor + Cable loss +Amp factor

2. Fundamental Carrier measurements for radiated emissions using a Peak detector with 1MHz VBW above 1GHz, A average detector with 10Hz VBW above 1GHz via Spectrum analyzer.

Low channel (above 1000MHz)

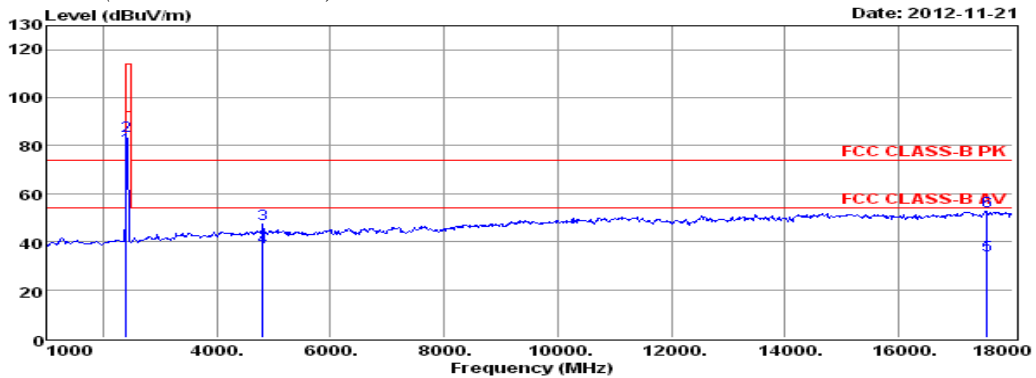

Env. /Ins: 24°C/56%  
 EUT: Wireless Webcam  
 M/N: C-151(Cyber Track V10)  
 Power Rating: DC 3.7V  
 Test Mode: Tx2403  
 Operator: Andy  
 Memo:  
 pol: HORIZONTAL

	Freq.	Reading	CabLos	AntFac	PreFac	Measured	Limit	Over	Remark
	MHz	dBuV	dB	dB/m	dB	dBuV/m	dBuV/m	dB	
3	4806.04	36.84	7.68	33.32	30.26	47.58	74.00	-26.42	Peak
4	4806.07	26.80	7.68	33.32	30.26	37.54	54.00	-16.46	Average
5	17557.96	12.72	11.17	41.28	30.81	34.36	54.00	-19.64	Average
6	17558.00	31.06	11.17	41.28	30.81	52.70	74.00	-21.30	Peak

Note: 1. All readings are Quasi-peak values.  
 2. Measured = Reading + Antenna Factor + Cable Loss - Amp Factor.  
 3. The emission levels that are 20dB below the official limit are not reported.

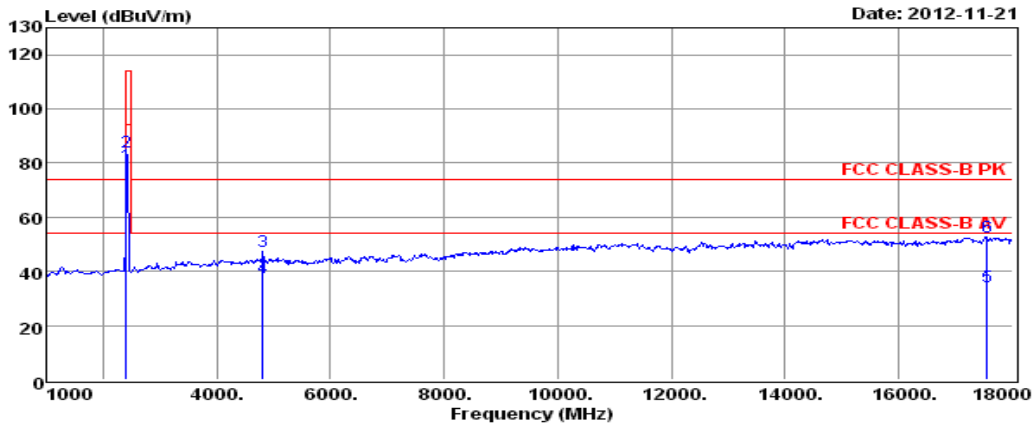

Env. /Ins: 24°C/56%  
 EUT: Wireless Webcam  
 M/N: C-151(Cyber Track V10)  
 Power Rating: DC 3.7V  
 Test Mode: Tx2403  
 Operator: Andy  
 Memo:  
 pol: HORIZONTAL

	Freq.	Reading	CabLos	AntFac	PreFac	Measured	Limit	Over	Remark
	MHz	dBuV	dB	dB/m	dB	dBuV/m	dBuV/m	dB	
3	4806.04	36.84	7.68	33.32	30.26	47.58	74.00	-26.42	Peak
4	4806.07	26.80	7.68	33.32	30.26	37.54	54.00	-16.46	Average
5	17557.96	12.72	11.17	41.28	30.81	34.36	54.00	-19.64	Average
6	17558.00	31.06	11.17	41.28	30.81	52.70	74.00	-21.30	Peak

Note: 1. All readings are Quasi-peak values.  
 2. Measured = Reading + Antenna Factor + Cable Loss - Amp Factor.  
 3. The emission levels that are 20dB below the official limit are not reported.

Mid channel (above 1000MHz)

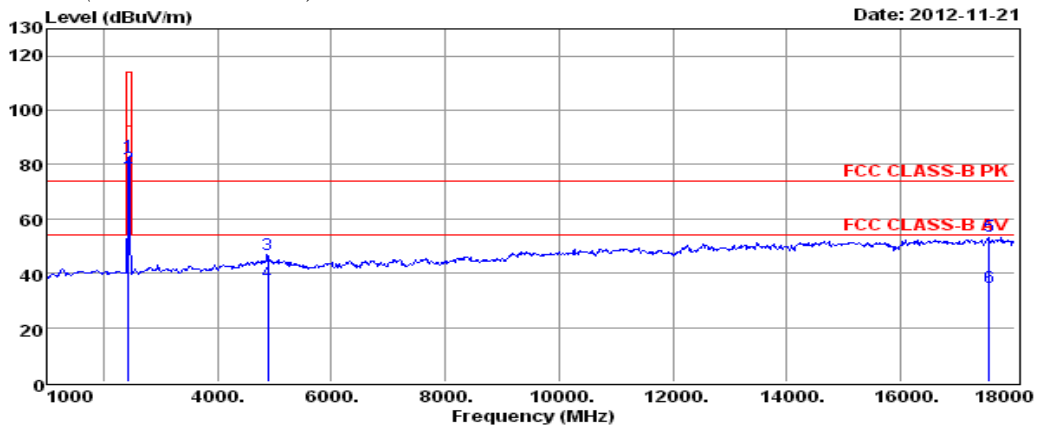

Env. /Ins: 24°C/56%  
 EUT: Wireless Webcam  
 M/N: C-151(Cyber Track V10)  
 Power Rating: DC 3.7V  
 Test Mode: Tx2442  
 Operator: Andy  
 Memo:  
 pol: HORIZONTAL

	Freq.	Reading	CabLos	AntFac	PreFac	Measured	Limit	Over	Remark
	MHz	dBuV	dB	dB/m	dB	dBuV/m	dBuV/m	dB	
3	4881.97	35.96	7.73	33.50	30.27	46.92	74.00	-27.08	Peak
4	4882.02	25.97	7.73	33.51	30.27	36.94	54.00	-17.06	Average
5	17558.00	32.10	11.17	41.28	30.81	53.74	74.00	-20.26	Peak
6	17558.11	13.16	11.17	41.28	30.81	34.80	54.00	-19.20	Average

Note: 1. All readings are Quasi-peak values.  
 2. Measured = Reading + Antenna Factor + Cable Loss - Amp Factor.  
 3. The emission levels that are 20dB below the official limit are not reported.

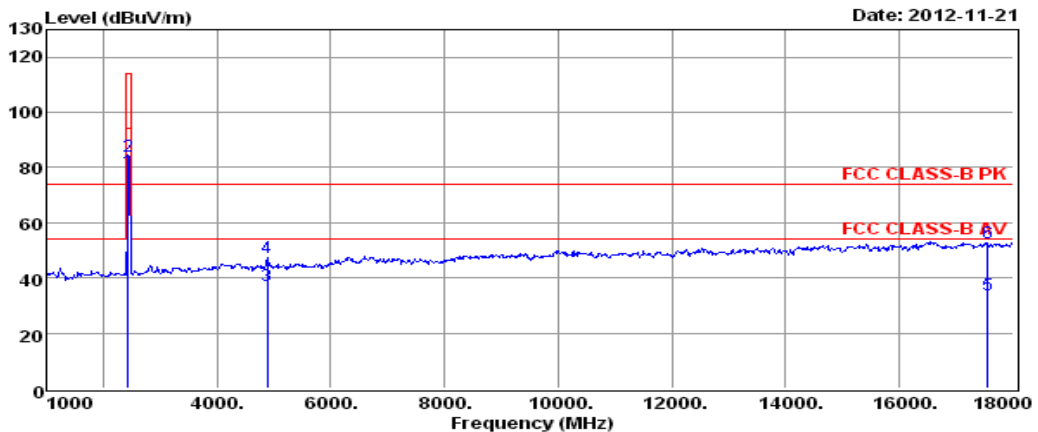

Env. /Ins: 24°C/56%  
 EUT: Wireless Webcam  
 M/N: C-151(Cyber Track V10)  
 Power Rating: DC 3.7V  
 Test Mode: Tx2442  
 Operator: Andy  
 Memo:  
 pol: VERTICAL

	Freq.	Reading	CabLos	AntFac	PreFac	Measured	Limit	Over	Remark
	MHz	dBuV	dB	dB/m	dB	dBuV/m	dBuV/m	dB	
3	4886.03	26.17	7.73	33.52	30.27	37.15	54.00	-16.85	Average
4	4886.04	36.25	7.73	33.52	30.27	47.23	74.00	-26.77	Peak
5	17557.96	12.28	11.17	41.28	30.81	33.92	54.00	-20.08	Average
6	17558.00	31.05	11.17	41.28	30.81	52.69	74.00	-21.31	Peak

Note: 1. All readings are Quasi-peak values.  
 2. Measured = Reading + Antenna Factor + Cable Loss - Amp Factor.  
 3. The emission levels that are 20dB below the official limit are not reported.

High channel (above 1000MHz)

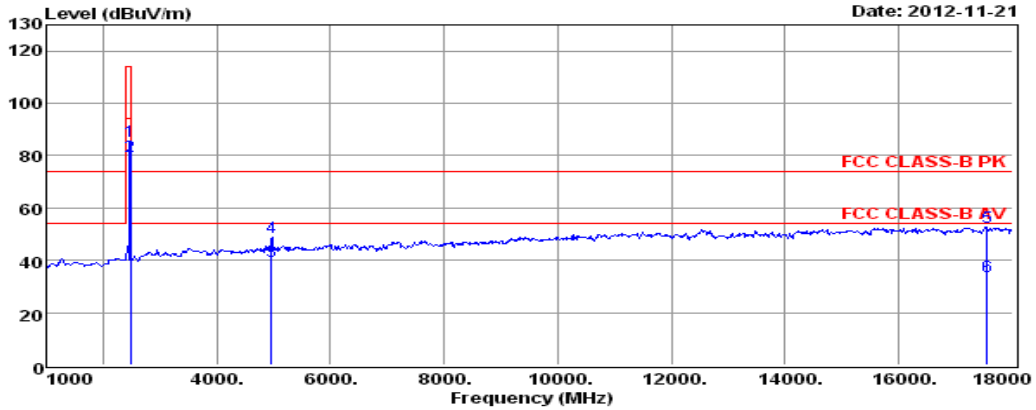

Date: 2012-11-21

Env. / Ins: 24°C/56%  
 EUT: Wireless Webcam  
 M/N: C-151(Cyber Track V10)  
 Power Rating: DC 3.7V  
 Test Mode: Tx2480  
 Operator: Andy  
 Memo:  
 pol: HORIZONTAL

	Freq.	Reading	CabLos	AntFac	PreFac	Measured	Limit	Over	Remark
	MHz	dBuV	dB	dB/m	dB	dBuV/m	dBuV/m	dB	
3	4960.13	28.59	7.78	33.70	30.27	39.80	54.00	-14.20	Average
4	4960.24	37.61	7.78	33.70	30.27	48.82	74.00	-25.18	Peak
5	17558.00	31.06	11.17	41.28	30.81	52.70	74.00	-21.30	Peak
6	17558.10	12.00	11.17	41.28	30.81	33.64	54.00	-20.36	Average

Note: 1. All readings are Quasi-peak values.  
 2. Measured = Reading + Antenna Factor + Cable Loss - Amp Factor.  
 3. The emission levels that are 20dB below the official limit are not reported.

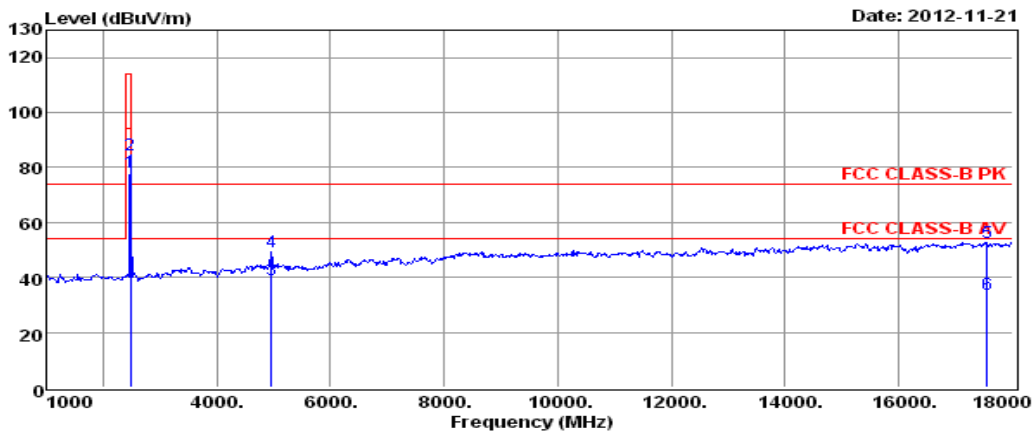

Date: 2012-11-21

Env. / Ins: 24°C/56%  
 EUT: Wireless Webcam  
 M/N: C-151(Cyber Track V10)  
 Power Rating: DC 3.7V  
 Test Mode: Tx2480  
 Operator: Andy  
 Memo:  
 pol: VERTICAL

	Freq.	Reading	CabLos	AntFac	PreFac	Measured	Limit	Over	Remark
	MHz	dBuV	dB	dB/m	dB	dBuV/m	dBuV/m	dB	
3	4960.87	27.75	7.78	33.70	30.27	38.96	54.00	-15.04	Average
4	4961.00	37.85	7.78	33.70	30.27	49.06	74.00	-24.94	Peak
5	17558.00	31.06	11.17	41.28	30.81	52.70	74.00	-21.30	Peak
6	17558.03	11.96	11.17	41.28	30.81	33.60	54.00	-20.40	Average

Note: 1. All readings are Quasi-peak values.  
 2. Measured = Reading + Antenna Factor + Cable Loss - Amp Factor.  
 3. The emission levels that are 20dB below the official limit are not reported.

(30MHz-1000MHz)

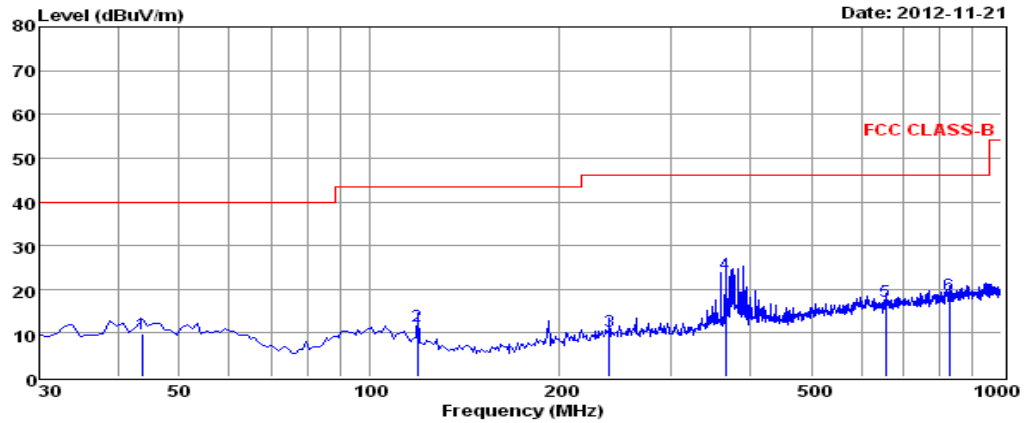

Env. /Ins: 24°C/56%  
 EUT: Wireless Webcam  
 M/N: C-151(Cyber Track V10)  
 Power Rating: DC 3.7V  
 Test Mode: Tx2403  
 Operator: Andy  
 Memo:  
 pol: HORIZONTAL

	Freq.	Reading	CabLos	AntFac	PreFac	Measured	Limit	Over	Remark
	MHz	dBuV	dB	dB/m	dB	dBuV/m	dBuV/m	dB	
1	43.58	26.11	0.41	13.56	30.14	9.94	40.00	-30.06	QP
2	119.24	30.46	0.64	10.61	30.20	11.51	43.50	-31.99	QP
3	239.52	27.56	1.01	12.07	30.18	10.46	46.00	-35.54	QP
4	365.62	38.03	1.14	14.47	30.12	23.52	46.00	-22.48	QP
5	655.65	27.00	1.50	18.65	30.03	17.12	46.00	-28.88	QP
6	826.37	26.83	1.80	20.33	30.11	18.85	46.00	-27.15	QP

Note: 1. All readings are Quasi-peak values.  
 2. Measured = Reading + Antenna Factor + Cable Loss - Amp Factor.  
 3. The emission levels that are 20dB below the official limit are not reported.

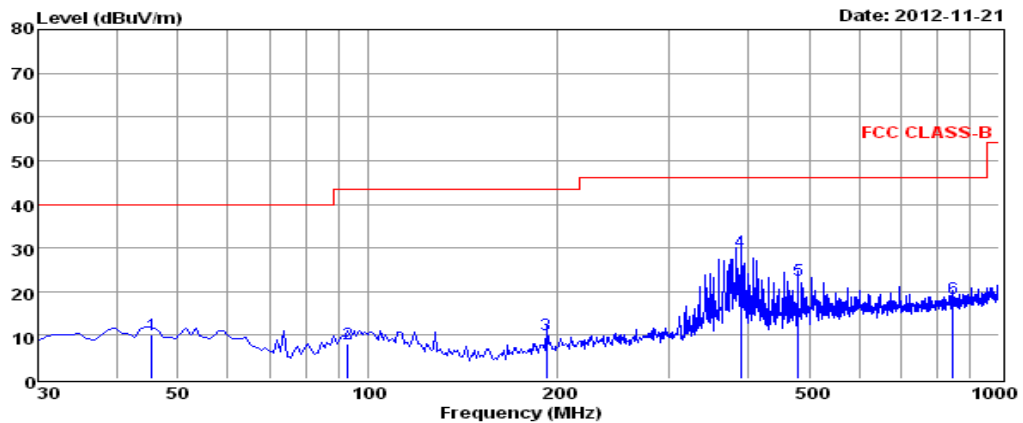

Env. /Ins: 24°C/56%  
 EUT: Wireless Webcam  
 M/N: C-151(Cyber Track V10)  
 Power Rating: DC 3.7V  
 Test Mode: Tx2403  
 Operator: Andy  
 Memo:  
 pol: VERTICAL

	Freq.	Reading	CabLos	AntFac	PreFac	Measured	Limit	Over	Remark
	MHz	dBuV	dB	dB/m	dB	dBuV/m	dBuV/m	dB	
1	45.52	26.22	0.41	13.52	30.14	10.01	40.00	-29.99	QP
2	93.05	25.18	0.56	12.47	30.19	8.02	43.50	-35.48	QP
3	191.99	29.11	0.76	10.56	30.20	10.23	43.50	-33.27	QP
4	389.87	43.32	1.17	14.82	30.11	29.20	46.00	-16.80	QP
5	480.08	35.28	1.31	16.07	30.06	22.60	46.00	-23.40	QP
6	846.74	26.11	1.76	20.54	30.11	18.30	46.00	-27.70	QP

Note: 1. All readings are Quasi-peak values.  
 2. Measured = Reading + Antenna Factor + Cable Loss - Amp Factor.  
 3. The emission levels that are 20dB below the official limit are not reported.

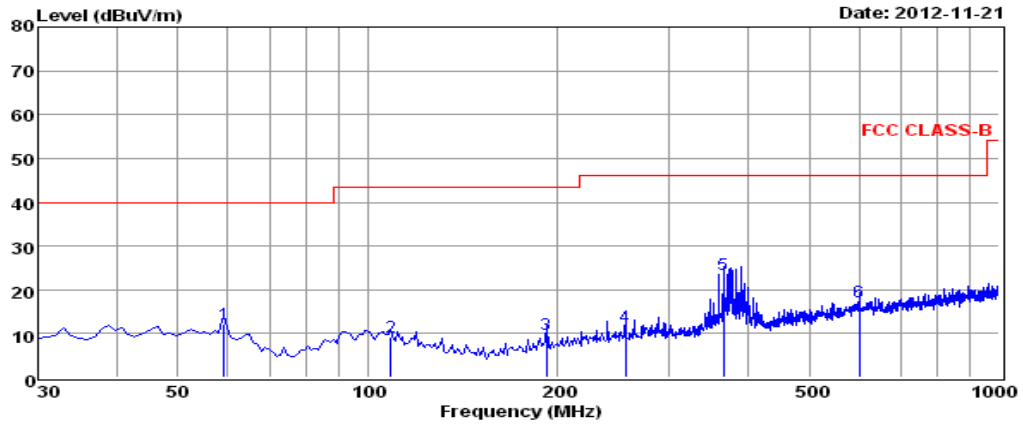

Env. / Ins: 24°C/56%  
 EUT: Wireless Webcam  
 M/N: C-151(Cyber Track V10)  
 Power Rating: DC 3.7V  
 Test Mode: Tx2442  
 Operator: Andy  
 Memo:  
 pol: HORIZONTAL

	Freq.	Reading	CabLos	AntFac	PreFac	Measured	Limit	Over	Remark
	MHz	dBuV	dB	dB/m	dB	dBuV/m	dBuV/m	dB	
1	59.10	29.14	0.49	12.75	30.15	12.23	40.00	-27.77	QP
2	108.57	26.26	0.68	12.38	30.20	9.12	43.50	-34.38	QP
3	191.99	28.76	0.76	10.56	30.20	9.88	43.50	-33.62	QP
4	256.01	28.76	1.02	12.06	30.17	11.67	46.00	-34.33	QP
5	365.62	37.93	1.14	14.47	30.12	23.42	46.00	-22.58	QP
6	600.36	27.51	1.43	18.45	30.00	17.39	46.00	-28.61	QP

Note: 1. All readings are Quasi-peak values.  
 2. Measured = Reading + Antenna Factor + Cable Loss - Amp Factor.  
 3. The emission levels that are 20dB below the official limit are not reported.

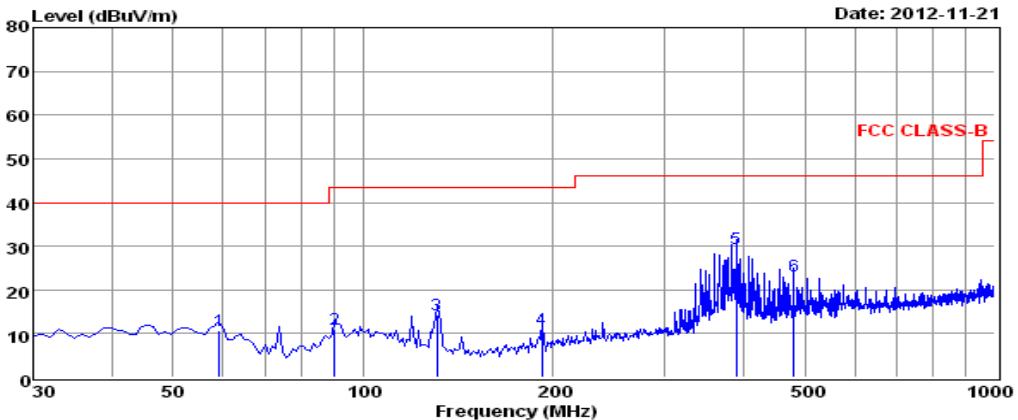

Env. / Ins: 24°C/56%  
 EUT: Wireless Webcam  
 M/N: C-151(Cyber Track V10)  
 Power Rating: DC 3.7V  
 Test Mode: Tx2442  
 Operator: Andy  
 Memo:  
 pol: VERTICAL

	Freq.	Reading	CabLos	AntFac	PreFac	Measured	Limit	Over	Remark
	MHz	dBuV	dB	dB/m	dB	dBuV/m	dBuV/m	dB	
1	59.10	27.58	0.49	12.75	30.15	10.67	40.00	-29.33	QP
2	90.14	28.61	0.68	11.93	30.19	11.03	43.50	-32.47	QP
3	130.88	34.97	0.76	8.86	30.20	14.39	43.50	-29.11	QP
4	191.99	29.93	0.76	10.56	30.20	11.05	43.50	-32.45	QP
5	389.87	43.65	1.17	14.82	30.11	29.53	46.00	-16.47	QP
6	480.08	35.79	1.31	16.07	30.06	23.11	46.00	-22.89	QP

Note: 1. All readings are Quasi-peak values.  
 2. Measured = Reading + Antenna Factor + Cable Loss - Amp Factor.  
 3. The emission levels that are 20dB below the official limit are not reported.

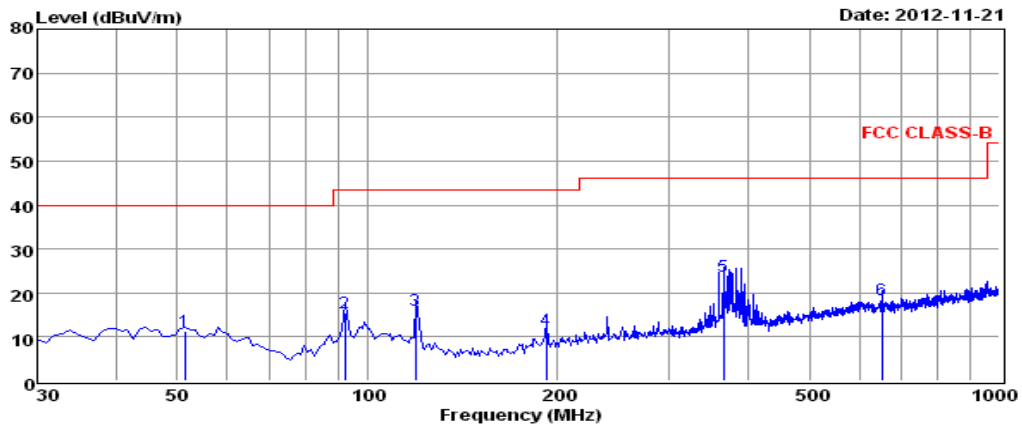

Env. /Ins: 24°C/56%  
 EUT: Wireless Webcam  
 M/N: C-151(Cyber Track V10)  
 Power Rating: DC 3.7V  
 Test Mode: Tx2480  
 Operator: Andy  
 Memo:  
 pol: HORIZONTAL

	Freq.	Reading	CabLos	AntFac	PreFac	Measured	Limit	Over	Remark
	MHz	dBuV	dB	dB/m	dB	dBuV/m	dBuV/m	dB	
1	51.34	27.74	0.54	13.19	30.15	11.32	40.00	-28.68	QP
2	92.08	32.81	0.56	12.29	30.19	15.47	43.50	-28.03	QP
3	119.24	35.03	0.64	10.61	30.20	16.08	43.50	-27.42	QP
4	191.99	30.51	0.76	10.56	30.20	11.63	43.50	-31.87	QP
5	365.62	38.27	1.14	14.47	30.12	23.76	46.00	-22.24	QP
6	651.77	28.31	1.58	18.64	30.03	18.50	46.00	-27.50	QP

Note: 1. All readings are Quasi-peak values.  
 2. Measured = Reading + Antenna Factor + Cable Loss - Amp Factor.  
 3. The emission levels that are 20dB below the official limit are not reported.

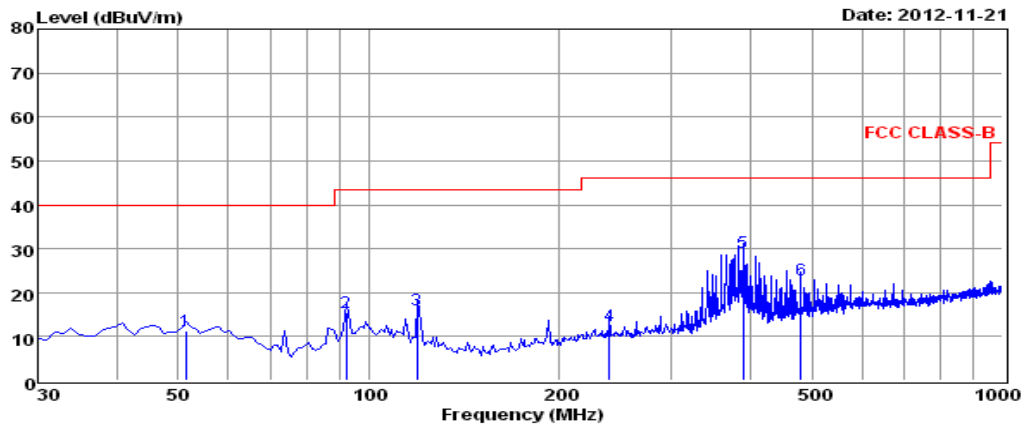

Env. /Ins: 24°C/56%  
 EUT: Wireless Webcam  
 M/N: C-151(Cyber Track V10)  
 Power Rating: DC 3.7V  
 Test Mode: Tx2480  
 Operator: Andy  
 Memo:  
 pol: VERTICAL

	Freq.	Reading	CabLos	AntFac	PreFac	Measured	Limit	Over	Remark
	MHz	dBuV	dB	dB/m	dB	dBuV/m	dBuV/m	dB	
1	51.34	27.81	0.54	13.19	30.15	11.39	40.00	-28.61	QP
2	92.08	32.81	0.56	12.29	30.19	15.47	43.50	-28.03	QP
3	119.24	35.03	0.64	10.61	30.20	16.08	43.50	-27.42	QP
4	239.52	29.67	1.01	12.07	30.18	12.57	46.00	-33.43	QP
5	389.87	43.40	1.17	14.82	30.11	29.28	46.00	-16.72	QP
6	480.08	35.51	1.31	16.07	30.06	22.83	46.00	-23.17	QP

Note: 1. All readings are Quasi-peak values.  
 2. Measured = Reading + Antenna Factor + Cable Loss - Amp Factor.  
 3. The emission levels that are 20dB below the official limit are not reported.

- Note:**
1. Radiated emissions measured in frequency range from 9 kHz to 26GHz were made with an instrument using Peak detector mode.
  2. The amplitude of spurious emissions which are attenuated by more than 20dB below the permissible value has no need to be reported. Measuring frequencies from 9 kHz to the 1GHz. No emission found between lowest internal used/generated frequency to 30 MHz.
  3. Measurements above show only up to 6 maximum emissions noted.
  4. The IF bandwidth of SPA 30MHz to 1GHz was 100KHz.
  5. Field strength limits for frequency above 1000MHz are based on average limits. However, Peak mode field strength shall not exceed the average limits specified plus 20dB. No emission found above 18GHz.



## 7. POWER LINE CONDUCTED EMISSIONS

### 7.1 Standard Applicable

According to §15.207 (a): For an intentional radiator which is designed to be connected to the public utility (AC) power line, the radio frequency voltage that is conducted back onto the AC power line on any frequency or frequencies within the band 150 kHz to 30 MHz shall not exceed 250 microvolts (The limit decreases linearly with the logarithm of the frequency in the range 0.15 MHz to 0.50 MHz). The limits at specific frequency range is listed as follows:

Frequency Range (MHz)	Limits (dBµV)	
	Quasi-peak	Average
0.15 to 0.50	66 to 56	56 to 46
0.50 to 5	56	46
5 to 30	60	50

### 7.2 Test Equipment

Item	Equipment	Manufacturer	Model No.	Serial No.	Last Cal.	Next Cal.
1	Test Receiver	Manufacturer	ESCS30	828985/018	2012-06-18	2013-06-17
2	L.I.S.N	Rohde & Schwarz	ESH2-Z5	834549/005	2012-06-18	2013-06-17
3	Pulse Limiter	Anritsu	ESH3-Z2	100006	2012-06-18	2013-06-17

### 7.3 Block Diagram of Test Setup

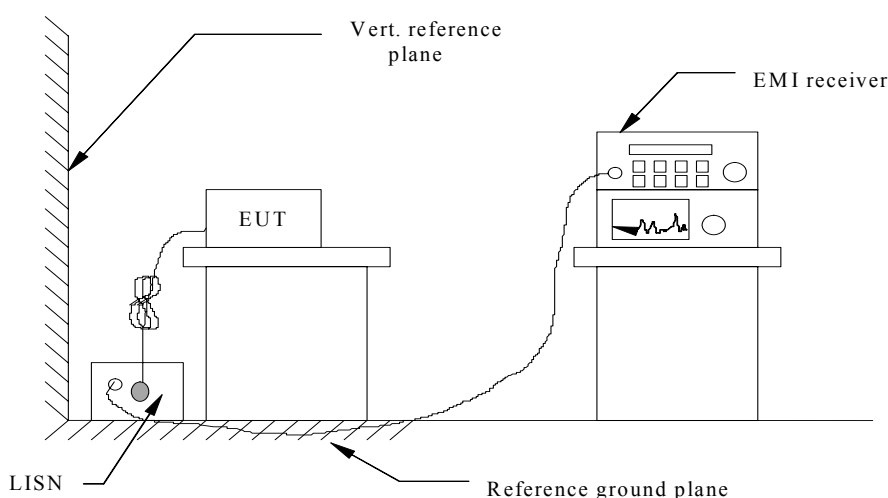

### 7.4 Test Data

PASS.

The test data please refer to following page.

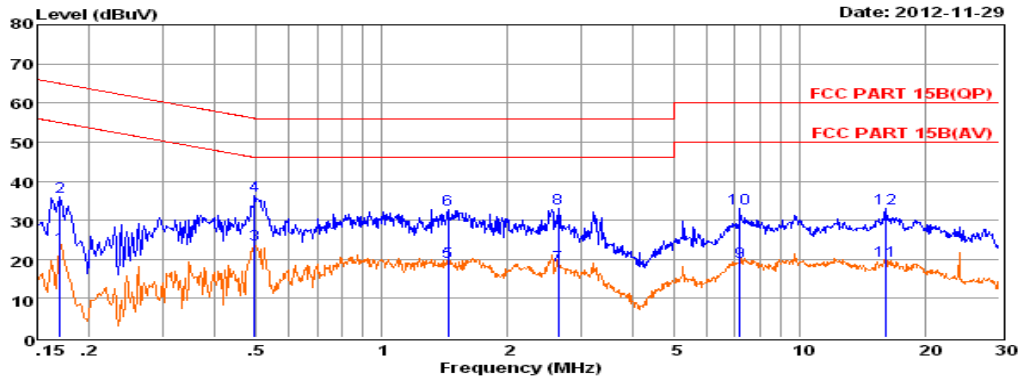

Env. Ins: 24\*/56%  
 EUT: Wireless Webcam  
 M/N: C-151(CyberTrack-V10)  
 Power Rating: DC 5V From PC Input AC 120V/60Hz  
 Test Mode: On  
 Operator: Fox  
 Memo:  
 Pol: LINE

	Freq	Reading	LisnFac	CabLos	Measured	Limit	Over	Remark
	MHz	dBuV	dB	dB	dBuV	dBuV	dB	
1	0.17	13.61	9.60	0.02	23.23	54.94	-31.71	Average
2	0.17	26.31	9.60	0.02	35.93	64.94	-29.01	QP
3	0.50	14.21	9.62	0.04	23.87	46.05	-22.18	Average
4	0.50	26.73	9.62	0.04	36.39	56.05	-19.66	QP
5	1.44	9.54	9.64	0.05	19.23	46.00	-26.77	Average
6	1.44	23.09	9.64	0.05	32.78	56.00	-23.22	QP
7	2.65	8.88	9.64	0.05	18.57	46.00	-27.43	Average
8	2.65	23.28	9.64	0.05	32.97	56.00	-23.03	QP
9	7.18	9.51	9.68	0.07	19.26	50.00	-30.74	Average
10	7.18	23.19	9.68	0.07	32.94	60.00	-27.06	QP
11	16.05	9.72	9.72	0.11	19.55	50.00	-30.45	Average
12	16.05	23.12	9.72	0.11	32.95	60.00	-27.05	QP

Remarks: 1. Measured = Reading + Lisn Factor +Cable Loss.  
 2. The emission levels that are 20dB below the official limit are not reported.

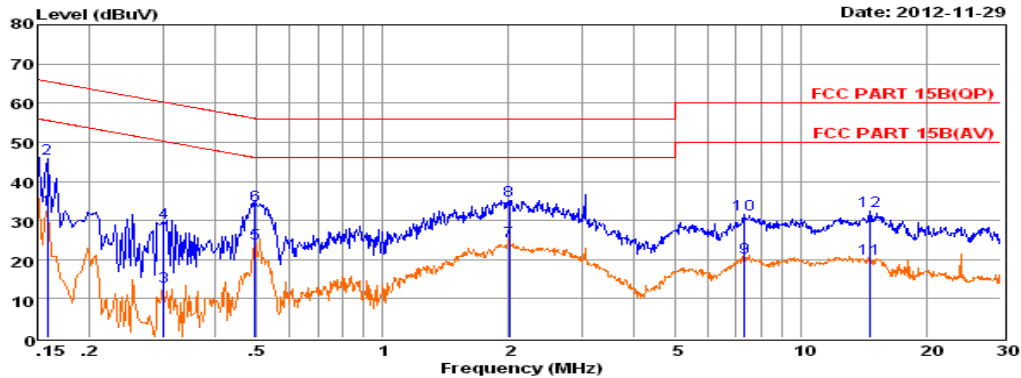

Env. Ins: 24\*/56%  
 EUT: Wireless Webcam  
 M/N: C-151(CyberTrack-V10)  
 Power Rating: DC 5V From PC Input AC 120V/60Hz  
 Test Mode: On  
 Operator: Fox  
 Memo:  
 Pol: NEUTRAL

	Freq	Reading	LisnFac	CabLos	Measured	Limit	Over	Remark
	MHz	dBuV	dB	dB	dBuV	dBuV	dB	
1	0.16	23.14	9.68	0.02	32.84	55.56	-22.72	Average
2	0.16	35.99	9.68	0.02	45.69	65.56	-19.87	QP
3	0.30	3.37	9.60	0.03	13.00	50.24	-37.24	Average
4	0.30	19.87	9.60	0.03	29.50	60.24	-30.74	QP
5	0.50	14.41	9.62	0.04	24.07	46.05	-21.98	Average
6	0.50	24.30	9.62	0.04	33.96	56.05	-22.09	QP
7	2.01	15.09	9.63	0.05	24.77	46.00	-21.23	Average
8	2.01	25.52	9.63	0.05	35.20	56.00	-20.80	QP
9	7.33	10.80	9.69	0.07	20.56	50.00	-29.44	Average
10	7.33	21.72	9.69	0.07	31.48	60.00	-28.52	QP
11	14.59	10.28	9.74	0.10	20.12	50.00	-29.88	Average
12	14.59	22.71	9.74	0.10	32.55	60.00	-27.45	QP

Remarks: 1. Measured = Reading + Lisn Factor +Cable Loss.  
 2. The emission levels that are 20dB below the official limit are not reported.

Note: Pre-scan all mode and recorded the worst case results in this report (Link mode).

This report shall not be reproduced except in full, without the written approval of Shenzhen LCS Compliance Testing Laboratory Ltd..

## 8. ANTENNA REQUIREMENT

### 8.1 Standard Applicable

#### 8.1.1. Standard Applicable

According to § 15.203, an intentional radiator shall be designed to ensure that no antenna other than that furnished by the responsible party shall be used with the device.

#### 8.1.2. Antenna Construction

Section 15.203 of the rules states that the subject device must meet at least one of the following criteria:

- (a) Antenna must be permanently attached to the unit.
- (b) Antenna must use a unique type of connector to attach to the EUT.
- (c) Unit must be professionally installed. Installer shall be responsible for verifying that the correct antenna is employed with the unit.

#### 8.1.3. Results

EUT uses a PCB antenna with 1.8dBi gain.

Compliance.

### 9. MANUFACTURER/ APPROVAL HOLDER DECLARATION

The following identical model(s):

--	--
----	----

Belong to the tested device:

Product description : Wireless Webcam

Model name : C-151(CyberTrack-V10)

No additional models were tested.

-----THE END OF REPORT-----