FCC Test Report

Report No.: AGC00931160404FE03

FCC ID : OYCBT064B
APPLICATION PURPOSE : Original Equipment
PRODUCT DESIGNATION : Bluetooth Speaker
BRAND NAME : SHARPER IMAGE
MODEL NAME : BT064B, SBT624, BT064
CLIENT : Dongguan Taide Industrial Co., Ltd.
DATE OF ISSUE : Apr.26,2016
STANDARD(S) : FCC Part 15 Rules
TEST PROCEDURE(S)
REPORT VERSION : V1.0

Attestation of Global Compliance (Shenzhen) Co., Ltd



CAUTION:

This report shall not be reproduced except in full without the written permission of the test laboratory and shall not be quoted out of context.

Report Revise Record

Report Version	Revise Time	Issued Date	Valid Version	Notes
V1.0	/	Apr.26,2016	Valid	Original Report

TABLE OF CONTENTS

1. VERIFICATION OF CONFORMITY	4
2. GENERAL INFORMATION	5
2.1. PRODUCT DESCRIPTION	5
2.2. TABLE OF CARRIER FREQUENCYS	5
5. SYSTEM TEST CONFIGURATION	8
5.1. CONFIGURATION OF EUT SYSTEM.....	8
5.2. EQUIPMENT USED IN EUT SYSTEM.....	8
5.3. SUMMARY OF TEST RESULTS.....	8
6. TEST FACILITY	9
7 TEST METHODOLOGY.....	9
8. ALL TEST EQUIPMENT LIST	9
9. RADIATED EMISSION	11
9.1TEST LIMIT.....	11
9.2. MEASUREMENT PROCEDURE.....	12
9.3. TEST SETUP.....	14
9.4. TEST RESULT	16
10. BAND EDGE EMISSION	31
10.1. MEASUREMENT PROCEDURE.....	31
10.2 TEST SETUP	31
10.3 RADIATED TEST RESULT	32
11. 20DB BANDWIDTH.....	36
11.1. MEASUREMENT PROCEDURE	36
11.2. TEST SET-UP	36
11.3. LIMITS AND MEASUREMENT RESULTS.....	36
12. FCC LINE CONDUCTED EMISSION TEST	43
12.1. LIMITS OF LINE CONDUCTED EMISSION TEST.....	43
12.2. BLOCK DIAGRAM OF LINE CONDUCTED EMISSION TEST.....	43
12.3. PRELIMINARY PROCEDURE OF LINE CONDUCTED EMISSION TEST	44
12.4. FINAL PROCEDURE OF LINE CONDUCTED EMISSION TEST.....	44
12.5. TEST RESULT OF LINE CONDUCTED EMISSION TEST.....	44
APPENDIX A: PHOTOGRAPHS OF TEST SETUP	47

1. VERIFICATION OF CONFORMITY

Applicant	Dongguan Taide Industrial Co., Ltd.
Address	Taide Technology Park, Jinfenghuang Industrial District, Fenggang Town, Dongguan City, China
Manufacturer	Dongguan Taide Industrial Co., Ltd.
Address	Taide Technology Park, Jinfenghuang Industrial District, Fenggang Town, Dongguan City, China
Product Designation	Bluetooth Speaker
Brand Name	SHARPER IMAGE
Test Model	BT064B
Series Models	SBT624, BT064
Difference description	Just name is different.
Date of test	Apr.11,2016 to Apr.13,2016
Deviation	None
Condition of Test Sample	Normal
Report Template	AGCRT-US-BR/RF

We hereby certify that:

The above equipment was tested by Dongguan Precise Testing Service Co., Ltd. The test data, the energy emitted by the sample tested as described in this report is in compliance with the requirements of FCC Rules Part 15.249.

Tested By 
Time Huang(Huang Nanhui) Apr.26,2016

Reviewed By 
Forrest Lei(Lei Yonggang) Apr.26,2016

Approved By 
Solger Zhang(Zhang Hongyi)
Authorized Officer Apr.26,2016

2. GENERAL INFORMATION

2.1. PRODUCT DESCRIPTION

A major technical description of EUT is described as following

Operation Frequency	2.402 GHz to 2.480GHz
RF Output Power	-2.86dBm(Max)
Bluetooth Version	V2.1+EDR
Modulation	GFSK ,π /4-DQPSK, 8DPSK
Number of channels	79
Hardware Version	BT064-AC4605-B REV:20160330
Software Version	V1.0
Antenna Designation	PCB Antenna
Antenna Gain	0dBi
Power Supply	Normal Voltage: DC 3.7V
Note: The USB port only used for charging and can't be used to transfer data with PC.	

2.2. TABLE OF CARRIER FREQUENCIES

BR/EDR channel List

Frequency Band	Channel Number	Frequency
2400~2483.5MHZ	0	2402MHZ
	1	2403MHZ
	:	:
	38	2440 MHZ
	39	2441 MHZ
	40	2442 MHZ
	:	:
	77	2479 MHZ
	78	2480 MHZ

3. MEASUREMENT UNCERTAINTY

The reported uncertainty of measurement $y \pm U$, where expanded uncertainty U is based on a standard uncertainty multiplied by a coverage factor of $k=2$, providing a level of confidence of approximately 95 %.

No.	Item	Uncertainty
1	Conducted Emission Test	$\pm 3.18\text{dB}$
2	All emissions, radiated	$\pm 3.91\text{dB}$
3	Temperature	$\pm 0.5^\circ\text{C}$
4	Humidity	$\pm 2\%$

4. DESCRIPTION OF TEST MODES

NO.	TEST MODE DESCRIPTION
1	Low channel TX
2	Middle channel TX
3	High channel TX
4	BT Link with charging

Note:

1. All the test modes can be supply by battery, only the result of the worst case was recorded in the report, if no other cases.
2. For Radiated Emission, 3axis were chosen for testing for each applicable mode.
3. The EUT used fully-charged battery when tested.

Software Setting

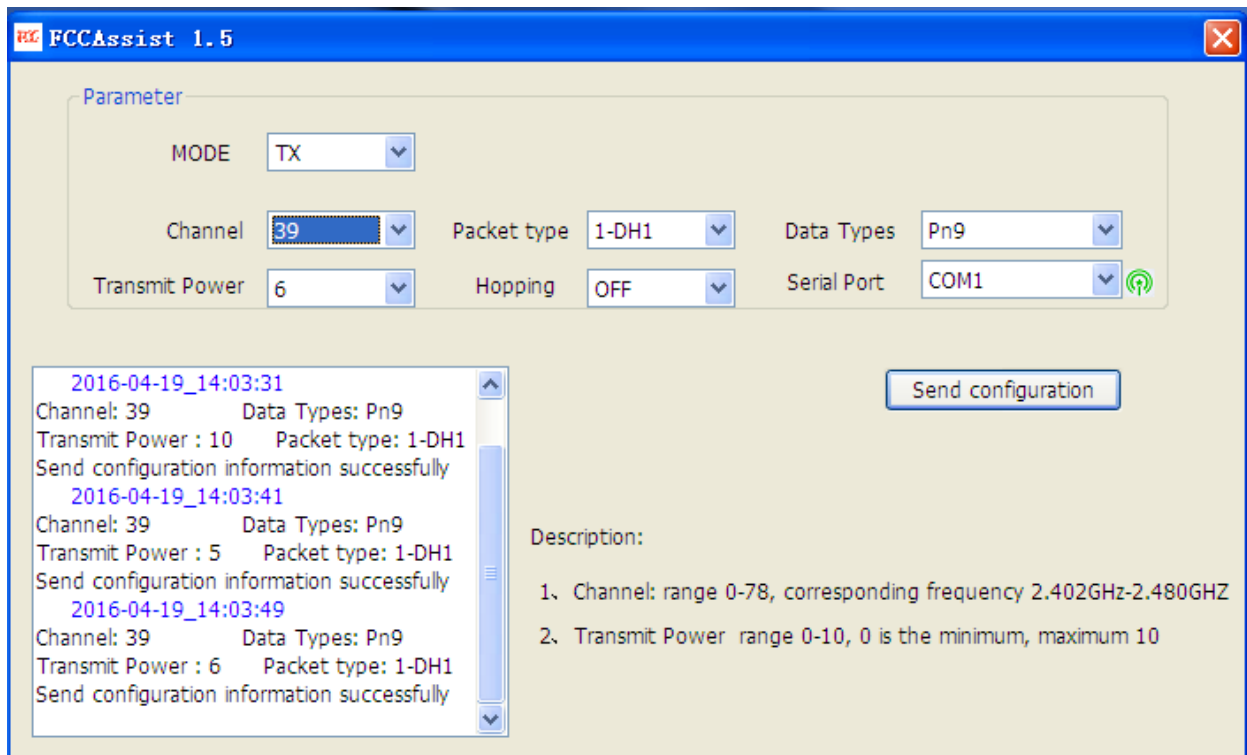

5. SYSTEM TEST CONFIGURATION

5.1. CONFIGURATION OF EUT SYSTEM

Configure 1: (Normal hopping)

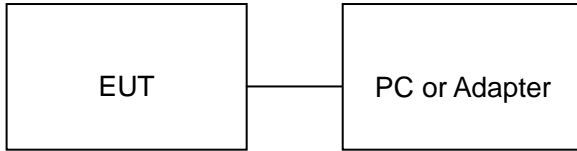

Note: Owing to the EUT has own battery, Testing will be performed while PC or Adapter remove.

Configure 2: (Control continuous TX)

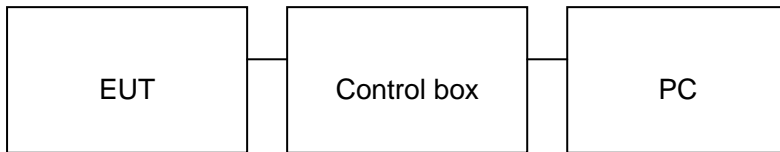

5.2. EQUIPMENT USED IN EUT SYSTEM

Item	Equipment	Model No.	ID or Specification	Remark
1	Bluetooth Speaker	N/A	BT064B	EUT
2	PC	SONY	E1412AYCW	A.E
3	Control box	N/A	N/A	A.E
4	Adapter	ETPCA-050100U3W	N/A	A.E
5	Temporary antenna connector	N/A	N/A	A.E

5.3. SUMMARY OF TEST RESULTS

FCC RULES	DESCRIPTION OF TEST	RESULT
§15.249	Radiated Emission	Compliant
§15.249	Band Edges	Compliant
§15.207	Conduction Emission	Compliant
§15.215	BANDWIDTH	Compliant

6. TEST FACILITY

Site	Dongguan Precise Testing Service Co., Ltd.
Location	Building D,Baoding Technology Park,Guangming Road2,Dongcheng District, Dongguan, Guangdong, China,
FCC Registration No.	371540
Description	The test site is constructed and calibrated to meet the FCC requirements in documents ANSI C63.4:2014.

7 TEST METHODOLOGY

All measurements contained in this report were conducted with ANSI C63.10-2013.

8. ALL TEST EQUIPMENT LIST

FOR RADIATED EMISSION TEST (BELOW 1GHZ)

Radiated Emission Test Site					
Name of Equipment	Manufacturer	Model Number	Serial Number	Last Calibration	Due Calibration
EMI Test Receiver	Rohde & Schwarz	ESCI	101417	July 4, 2015	July 3, 2016
Trilog Broadband Antenna (25M-1GHz)	SCHWARZBECK	VULB9160	9160-3355	July 4, 2015	July 3, 2016
Signal Amplifier	SCHWARZBECK	BBV 9475	9745-0013	July 4, 2015	July 3, 2016
RF Cable	SCHWARZBECK	AK9515E	96221	July 4, 2015	July 3, 2016
3m Anechoic Chamber	CHENGYU	966	PTS-001	June 6, 2015	June 5, 2016
MULTI-DEVICE Positioning Controller	Max-Full	MF-7802	MF780208339	N/A	N/A
Active loop antenna (9K-30MHz)	Schwarzbeck	FMZB1519	1519-038	June 6, 2015	June 5, 2016
Spectrum analyzer	Agilent	E4407B	MY46185649	June 6, 2015	June 5, 2016
Radiation Cable 1	MXT	RS1	R005	June 6, 2015	June 5, 2016
Radiation Cable 2	MXT	RS1	R006	June 6, 2015	June 5, 2016

FOR RADIATED EMISSION TEST (1GHZ ABOVE)

Radiated Emission Test Site					
Name of Equipment	Manufacturer	Model Number	Serial Number	Last Calibration	Due Calibration
EMI Test Receiver	Rohde & Schwarz	ESCI	101417	July 4, 2015	July 3, 2016
Horn Antenna (1G-18GHz)	SCHWARZBECK	BBHA9120D	9120D-1246	July 11, 2015	July 10, 2016
Spectrum Analyzer	Agilent	E4411B	MY4511453	July 4, 2015	July 3, 2016
Signal Amplifier	SCHWARZBECK	BBV 9718	9718-269	July 7, 2015	July 6, 2016
RF Cable	SCHWARZBECK	AK9515H	96220	July 8, 2015	July 7, 2016
3m Anechoic Chamber	CHENGYU	966	PTS-001	June 6, 2015	June 5, 2016
MULTI-DEVICE Positioning Controller	Max-Full	MF-7802	MF780208339	N/A	N/A
Horn Ant (18G-40GHz)	Schwarzbeck	BBHA 9170	9170-181	June 6, 2015	June 5, 2016
Radiation Cable 1	MXT	RS1	R005	June 6, 2015	June 5, 2016
Radiation Cable 2	MXT	RS1	R006	June 6, 2015	June 5, 2016

Conducted Emission Test Site					
Name of Equipment	Manufacturer	Model Number	Serial Number	Last Calibration	Due Calibration
EMI Test Receiver	Rohde & Schwarz	ESCI	101417	July 4, 2015	July 3, 2016
Artificial Mains Network	Narda	L2-16B	000WX31025	July 8, 2015	July 7, 2016
Artificial Mains Network (AUX)	Narda	L2-16B	000WX31026	July 8, 2015	July 7, 2016
RF Cable	SCHWARZBECK	AK9515E	96222	July 4, 2015	July 3, 2016
Shielded Room	CHENGYU	843	PTS-002	June 6,2015	June 5,2016
Conduction Cable	MXT	SE1	S003	June 6,2015	June 5,2016

9. RADIATED EMISSION

9.1 TEST LIMIT

Standard FCC15.249

Fundamental Frequency	Field Strength of Fundamental (millivolts/meter)	Field Strength of Harmonics (microvolts/meter)
900-928MHz	50	500
2400-2483.5MHz	50	500
5725-5875MHz	50	500
24.0-24.25GHz	250	2500

Standard FCC 15.209

Frequency (MHz)	Distance Meters	Field Strengths Limit	
		μ V/m	dB(μ V)/m
0.009 ~ 0.490	300	2400/F(kHz)	---
0.490 ~ 1.705	30	24000/F(kHz)	---
1.705 ~ 30	30	30	---
30 ~ 88	3	100	40.0
88 ~ 216	3	150	43.5
216 ~ 960	3	200	46.0
960 ~ 1000	3	500	54.0
Above 1000	3	Other:74.0 dB(μ V)/m (Peak) 54.0 dB(μ V)/m (Average)	

Remark: (1) Emission level $\text{dB}\mu\text{V} = 20 \log \text{Emission level } \mu\text{V/m}$
(2) The smaller limit shall apply at the cross point between two frequency bands.
(3) Distance is the distance in meters between the measuring instrument, antenna and the closest point of any part of the device or system.

9.2. MEASUREMENT PROCEDURE

1. The EUT was placed on the top of the turntable 0.8 or 1.5 meter above ground. The phase center of the receiving antenna mounted on the top of a height-variable antenna tower was placed 3 meters far away from the turntable.
2. Power on the EUT and all the supporting units. The turntable was rotated by 360 degrees to determine the position of the highest radiation.
3. The height of the broadband receiving antenna was varied between one meter and four meters above ground to find the maximum emissions field strength of both horizontal and vertical polarization.
4. For each suspected emissions, the antenna tower was scan (from 1 M to 4 M) and then the turntable was rotated (from 0 degree to 360 degrees) to find the maximum reading.
5. Set the test-receiver system to Peak or CISPR quasi-peak Detect Function with specified bandwidth under Maximum Hold Mode.
6. For emissions above 1GHz, use 1MHz VBW and RBW for peak reading. Then 1MHz RBW and 10Hz VBW for average reading in spectrum analyzer.

Place the measurement antenna away from each area of the EUT determined to be a source of emissions at the specified measurement distance, while keeping the measurement antenna aimed at the source of emissions at each frequency of significant emissions, with polarization oriented for maximum response. The measurement antenna may have to be higher or lower than the EUT, depending on the radiation pattern of the emission and staying aimed at the emission source for receiving the maximum signal. The final measurement antenna elevation shall be that which maximizes the emissions. The measurement antenna elevation for maximum emissions shall be restricted to a range of heights of from 1 m to 4 m above the ground or reference ground plane.

7. When the radiated emissions limits are expressed in terms of the average value of the emissions, and pulsed operation is employed, the measurement field strength shall be determined by averaging over one complete pulse train, including blanking intervals, as long as the pulse train does not exceed 0.1 seconds. As an alternative (provided the transmitter operates for longer than 0.1 seconds) or in cases where the pulse train exceeds 0.1 seconds, the measured field strength shall be determined from the average absolute voltage during a 0.1 second interval during which the field strength is at its maximum values.
8. If the emissions level of the EUT in peak mode was 3 dB lower than the average limit specified, then testing will be stopped and peak values of EUT will be reported, otherwise, the emissions which do not have 3 dB margin will be repeated one by one using the quasi-peak method for below 1GHz.
9. For testing above 1GHz, the emissions level of the EUT in peak mode was lower than average limit (that means the emissions level in peak mode also complies with the limit in average mode), then testing will be stopped and peak values of EUT will be reported, otherwise, the emissions will be measured in average mode again and reported.
10. In case the emission is lower than 30MHz, loop antenna has to be used for measurement and the recorded data should be QP measured by receiver. High - Low scan is not required in this case.

The following table is the setting of spectrum analyzer and receiver.

Spectrum Parameter	Setting
Start ~Stop Frequency	9KHz~150KHz/RB 200Hz for QP
Start ~Stop Frequency	150KHz~30MHz/RB 9KHz for QP
Start ~Stop Frequency	30MHz~1000MHz/RB 120KHz for QP
Start ~Stop Frequency	1GHz~26.5GHz 1MHz/3MHz for Peak, 1MHz/10Hz for Average

Receiver Parameter	Setting
Start ~Stop Frequency	9KHz~150KHz/RB 200Hz for QP
Start ~Stop Frequency	150KHz~30MHz/RB 9KHz for QP
Start ~Stop Frequency	30MHz~1000MHz/RB 120KHz for QP

9.3. TEST SETUP

Radiated Emission Test-Setup Frequency Below 30MHz



RADIATED EMISSION TEST SETUP 30MHz-1000MHz

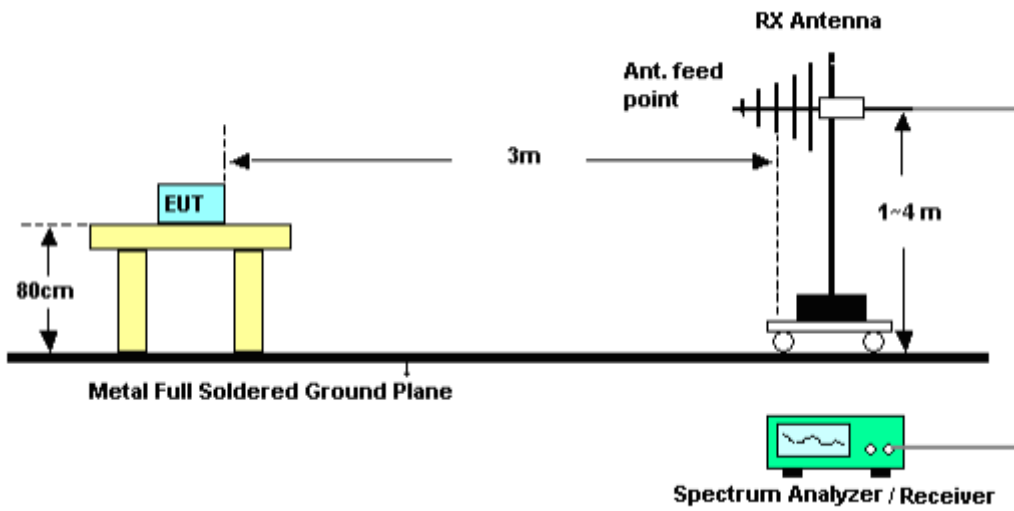

RADIATED EMISSION TEST SETUP ABOVE 1000MHz



9.4. TEST RESULT

(Worst modulation: GFSK)

RADIATED EMISSION BELOW 30MHZ

No emission found between lowest internal used/generated frequencies to 30MHz.

RADIATED EMISSION BELOW 1GHZ

RADIATED EMISSION TEST- (30MHZ-1GHZ)-LOW CHANNEL-HORIZONTAL

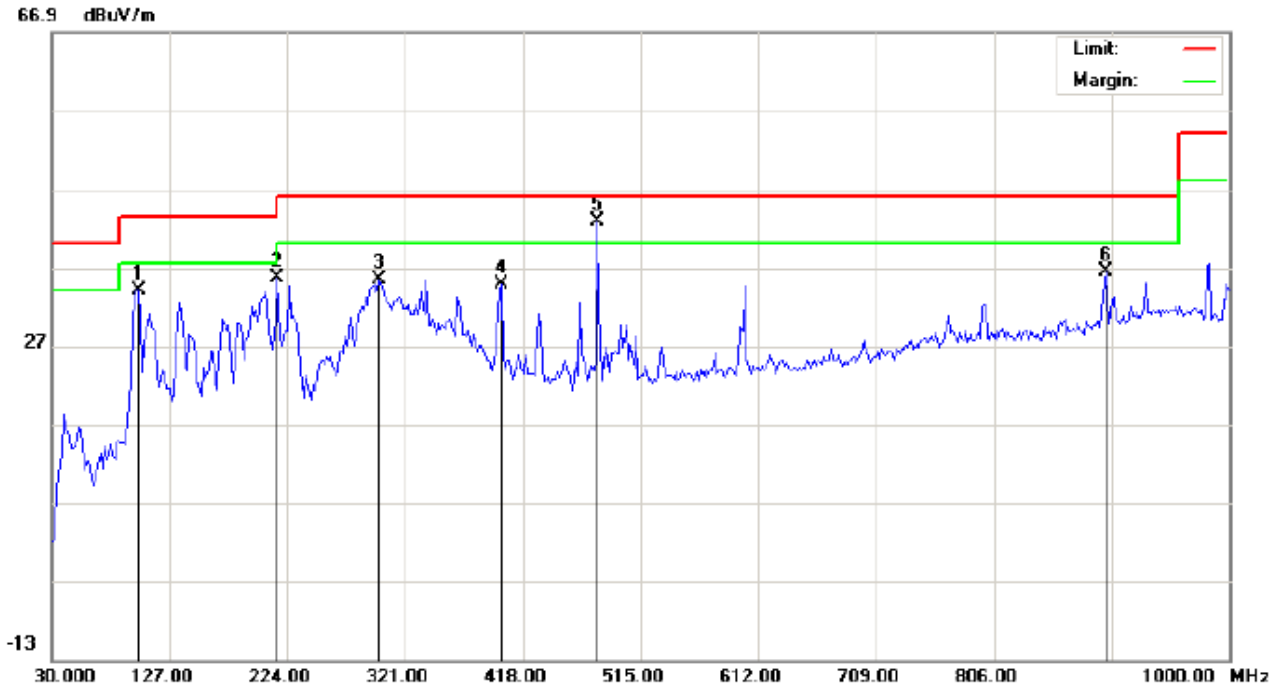

Site: site #1
Limit: FCC Class B 3M Radiation
EUT: Bluetooth Speaker
M/N: BT064B
Mode: Low Channel TX
Note:

Polarization: *Horizontal*
Power:
Distance:

Temperature: 22.7
Humidity: 56.5 %

No.	Mk	Freq.	Reading	Factor	Measurement	Limit	Over	Detector	Antenna Height	Table Degree	Comment
		MHz	dBuV	dB/m	dBuV/m	dBuV/m	dB		cm	degree	
1		101.1333	23.85	10.22	34.07	43.50	-9.43	peak			
2		215.9167	25.22	10.38	35.60	43.50	-7.90	peak			
3		299.9833	20.06	15.41	35.47	46.00	-10.53	peak			
4		400.2167	15.69	19.08	34.77	46.00	-11.23	peak			
5	*	479.4333	21.86	20.91	42.77	46.00	-3.23	peak			
6		898.1500	7.90	28.56	36.46	46.00	-9.54	peak			

RESULT : PASS

RADIATED EMISSION TEST- (30MHZ-1GHZ)-LOW CHANNEL -VERTICAL

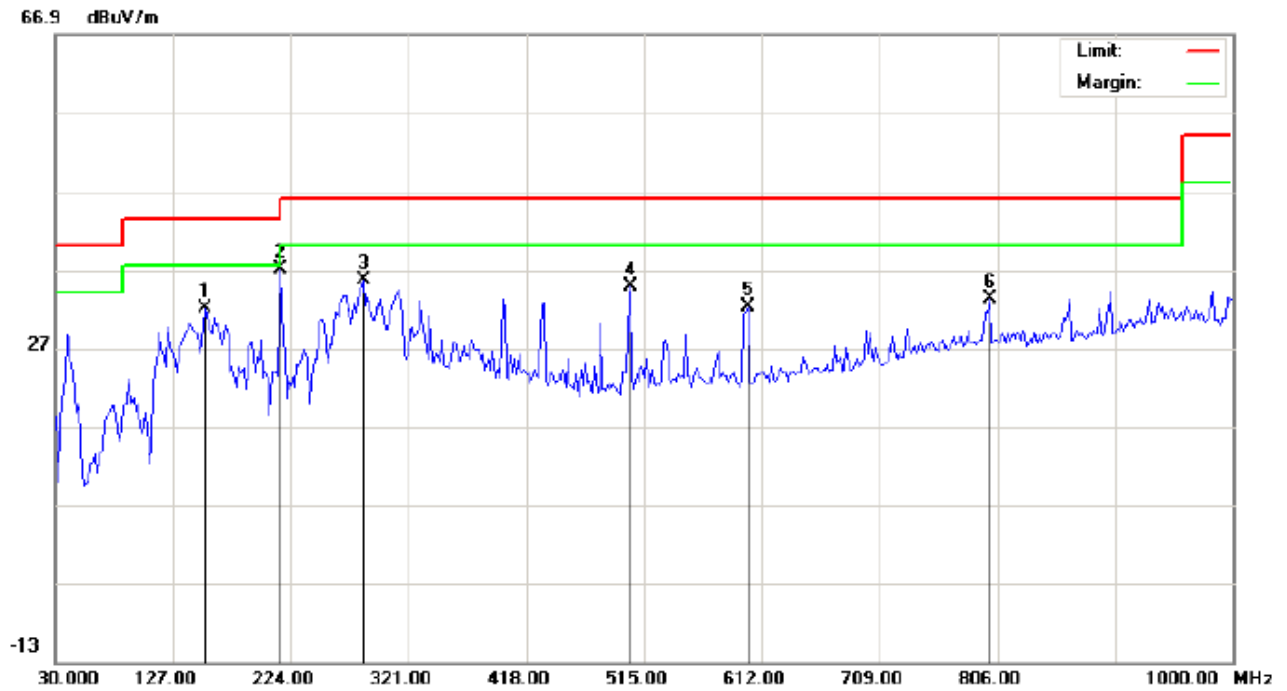

Site: site #1
Limit: FCC Class B 3M Radiation
EUT: Bluetooth Speaker
M/N: BT064B
Mode: Low Channel TX
Note:

Polarization: *Vertical*
Power:
Distance:

Temperature: 22.7
Humidity: 56.5 %

No.	Mk	Freq.	Reading	Factor	Measurement	Limit	Over	Detector	Antenna Height	Table Degree	Comment
		MHz	dBuV	dB/m	dBuV/m	dBuV/m	dB		cm	degree	
1		152.8667	16.73	15.28	32.01	43.50	-11.49	peak			
2	*	215.9167	26.36	10.56	36.92	43.50	-6.58	peak			
3		283.8167	20.71	14.92	35.63	46.00	-10.37	peak			
4		503.6833	13.51	21.23	34.74	46.00	-11.26	peak			
5		600.6833	9.52	22.75	32.27	46.00	-13.73	peak			
6		799.5333	5.82	27.31	33.13	46.00	-12.87	peak			

RESULT: PASS

Note: 1. Factor=Antenna Factor + Cable loss, Margin=Measurement-Limit.

2. The "Factor" value can be calculated automatically by software of measurement system.

RADIATED EMISSION TEST- (30MHZ-1GHZ)-MIDDLE CHANNEL-HORIZONTAL

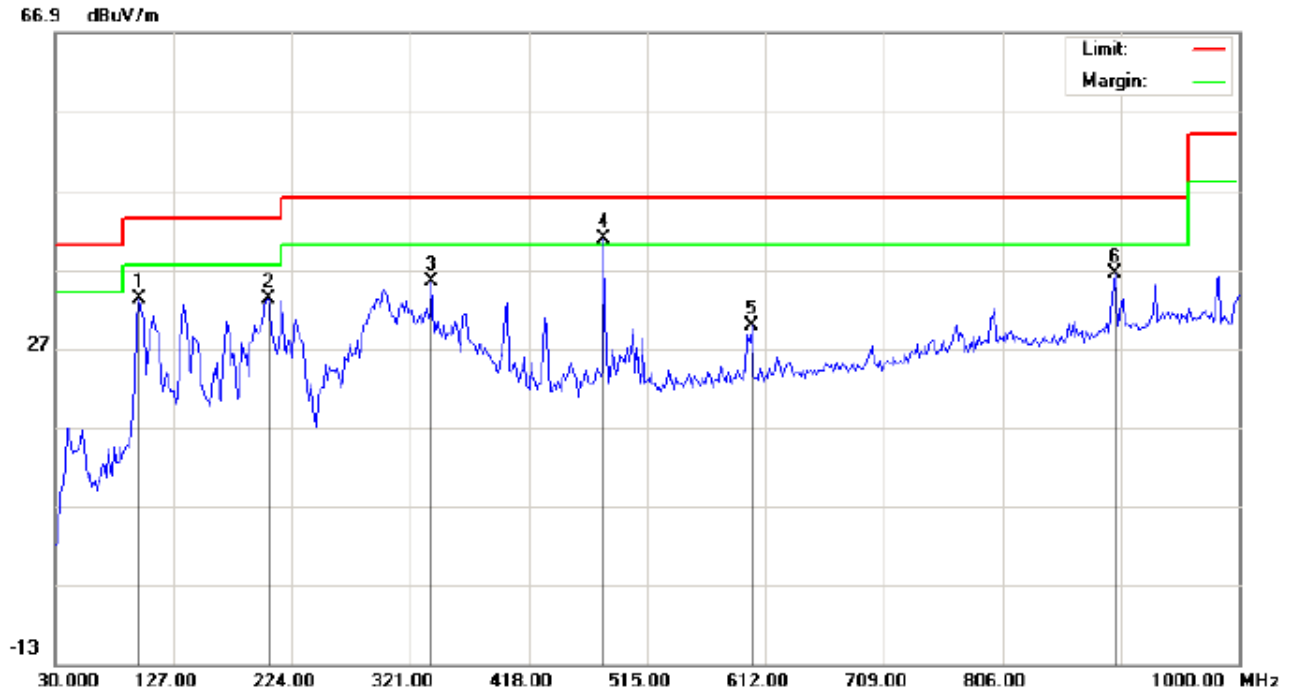

Site: site #1
Limit: FCC Class B 3M Radiation
EUT: Bluetooth Speaker
M/N: BT064B
Mode: Middle Channel TX
Note:

Polarization: *Horizontal*
Power:
Distance:

Temperature: 22.7
Humidity: 56.5 %

No.	Mk	Freq.	Reading	Factor	Measurement	Limit	Over	Detector	Antenna Height	Table Degree	Comment
		MHz	dBuV	dB/m	dBuV/m	dBuV/m	dB		cm	degree	
1		99.5167	23.13	10.00	33.13	43.50	-10.37	peak			
2		204.6000	21.66	11.53	33.19	43.50	-10.31	peak			
3		338.7833	17.40	17.99	35.39	46.00	-10.61	peak			
4	*	479.4333	19.91	20.91	40.82	46.00	-5.18	peak			
5		600.6833	6.00	23.73	29.73	46.00	-16.27	peak			
6		898.1500	7.90	28.56	36.46	46.00	-9.54	peak			

RESULT: PASS

RADIATED EMISSION TEST- (30MHZ-1GHZ)- MIDDLE CHANNEL -VERTICAL

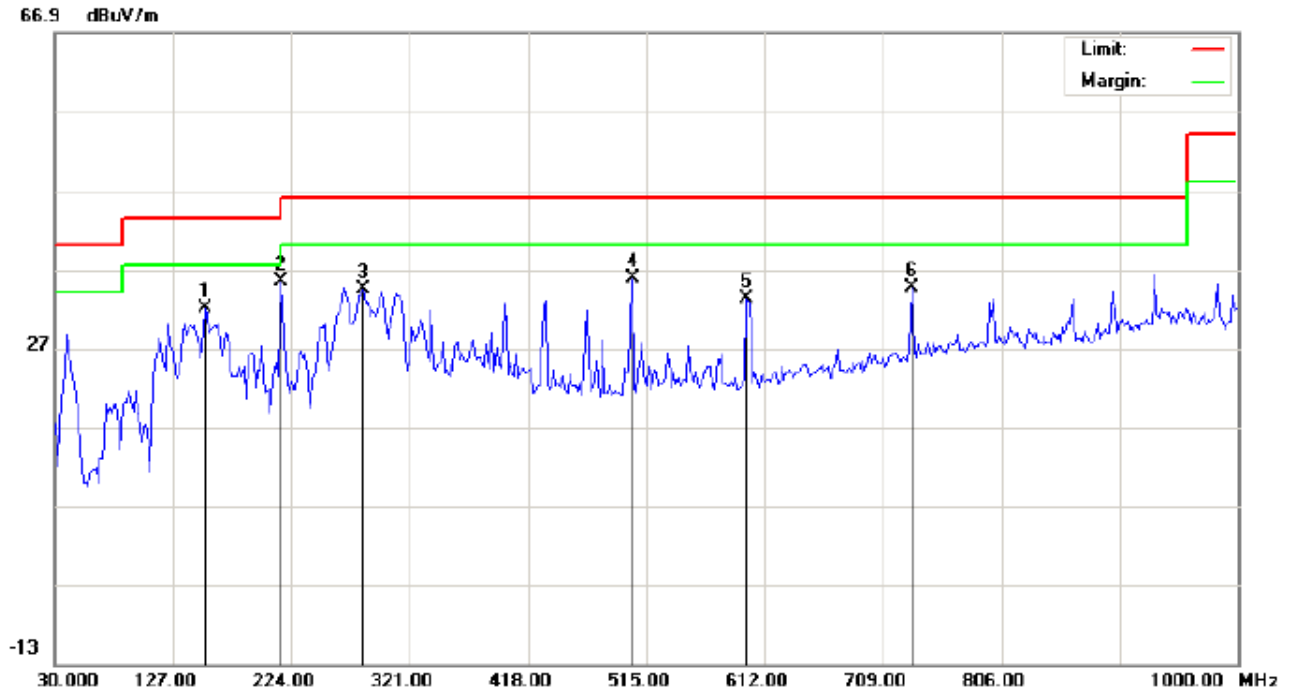

Site: site #1
Limit: FCC Class B 3M Radiation
EUT: Bluetooth Speaker
M/N: BT064B
Mode: Middle Channel TX
Note:

Polarization: *Vertical*
Power:
Distance:

Temperature: 22.7
Humidity: 56.5 %

No.	Mk	Freq.	Reading	Factor	Measurement	Limit	Over	Detector	Antenna Height	Table Degree	Comment
		MHz	dBuV	dB/m	dBuV/m	dBuV/m	dB		cm	degree	
1		152.8667	16.80	15.28	32.08	43.50	-11.42	peak			
2	*	215.9167	24.77	10.56	35.33	43.50	-8.17	peak			
3		282.2000	19.49	14.87	34.36	46.00	-11.64	peak			
4		503.6833	14.58	21.23	35.81	46.00	-10.19	peak			
5		597.4500	10.48	22.72	33.20	46.00	-12.80	peak			
6		733.2500	8.37	26.15	34.52	46.00	-11.48	peak			

RESULT: PASS

Note: 1. Factor=Antenna Factor + Cable loss, Margin=Measurement-Limit.

2. The "Factor" value can be calculated automatically by software of measurement system.

RADIATED EMISSION TEST- (30MHZ-1GHZ)-HIGH CHANNEL-HORIZONTAL

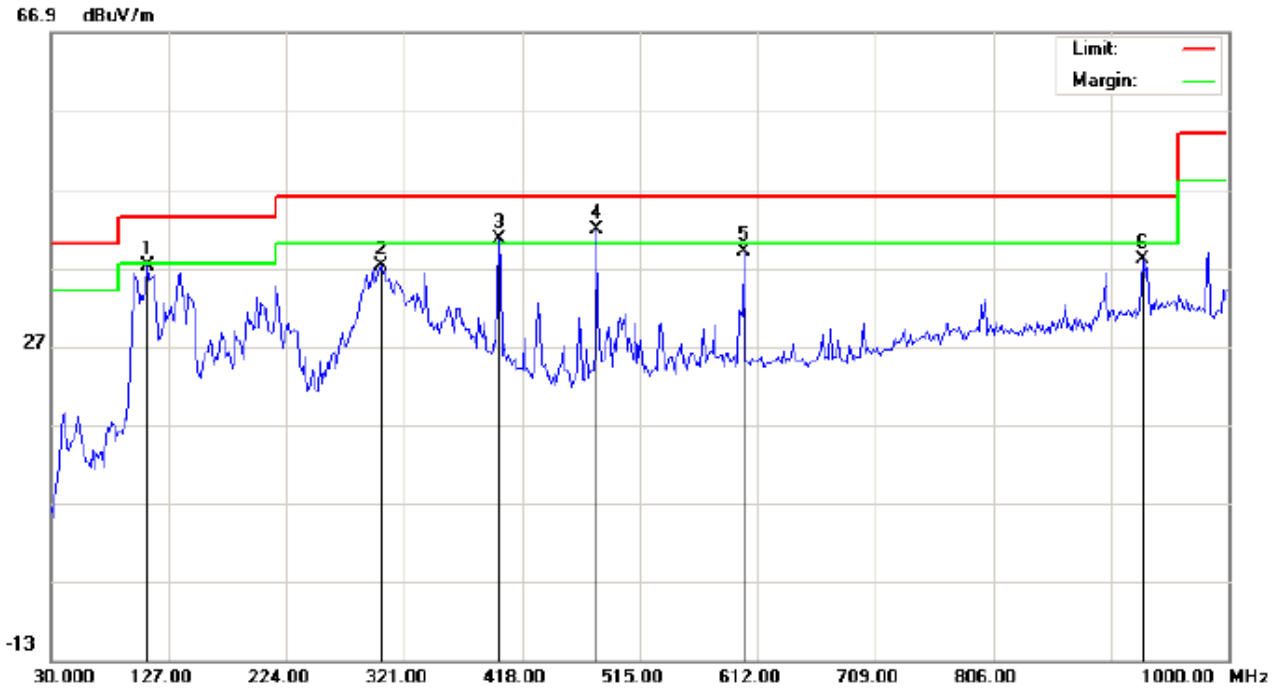

Site: site #1
Limit: FCC Class B 3M Radiation
EUT: Bluetooth Speaker
M/N: BT064B
Mode: High Channel TX
Note:

Polarization: *Horizontal*
Power:
Distance:

Temperature: 22.7
Humidity: 56.5 %

No.	Mk	Freq.	Reading	Factor	Measurement	Limit	Over	Detector	Antenna Height	Table Degree	Comment
		MHz	dBuV	dB/m	dBuV/m	dBuV/m	dB		cm	degree	
1		109.2167	28.78	8.35	37.13	43.50	-6.37	peak			
2		301.6000	21.63	15.52	37.15	46.00	-8.85	peak			
3	!	398.6000	21.48	19.06	40.54	46.00	-5.46	peak			
4	*	479.4333	20.97	20.91	41.88	46.00	-4.12	peak			
5		600.6833	15.31	23.73	39.04	46.00	-6.96	peak			
6		928.8667	8.57	29.41	37.98	46.00	-8.02	peak			

RESULT: PASS

RADIATED EMISSION TEST- (30MHZ-1GHZ)-HIGH CHANNEL -VERTICAL

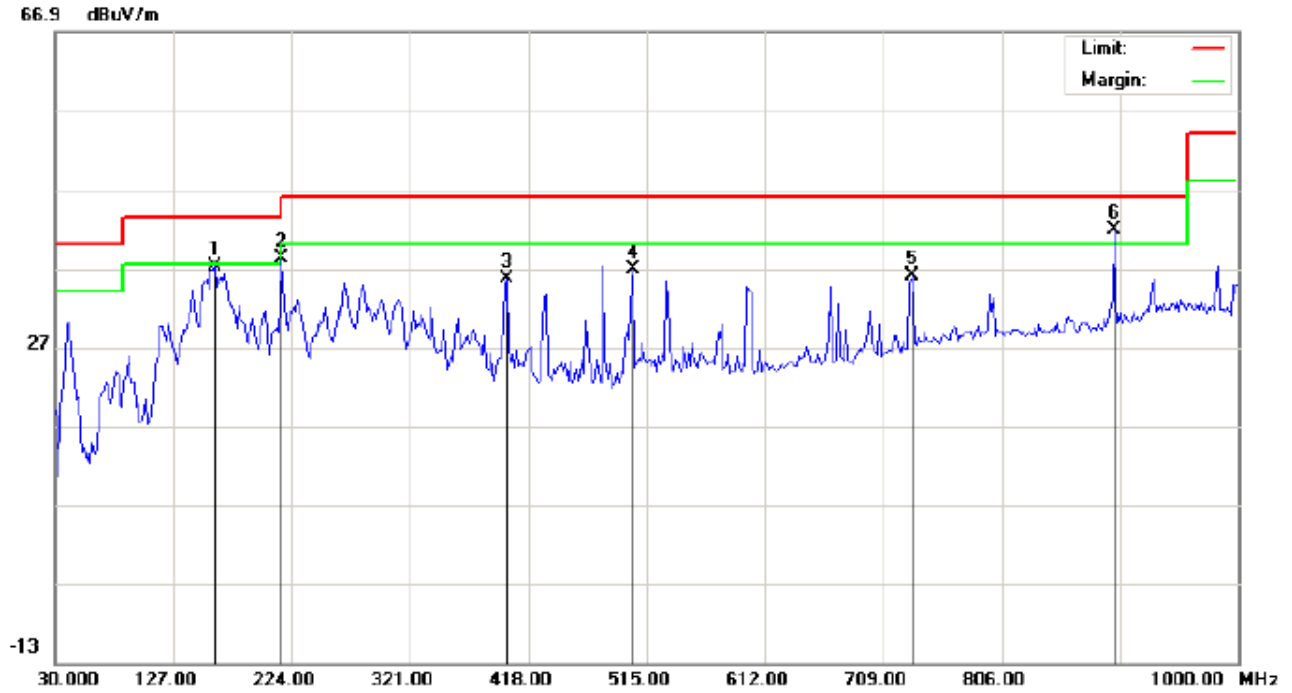

Site: site #1
Limit: FCC Class B 3M Radiation
EUT: Bluetooth Speaker
M/N: BT064B
Mode: High Channel TX
Note:

Polarization: **Vertical**
Power:
Distance:

Temperature: 22.7
Humidity: 56.5 %

No.	Mk	Freq.	Reading	Factor	Measurement	Limit	Over	Detector	Antenna Height	Table Degree	Comment
		MHz	dBuV	dB/m	dBuV/m	dBuV/m	dB		cm	degree	
1		160.9500	21.86	15.27	37.13	43.50	-6.37	peak			
2	!	215.9167	27.61	10.56	38.17	43.50	-5.33	peak			
3		400.2167	16.52	19.08	35.60	46.00	-10.40	peak			
4		503.6833	15.59	21.23	36.82	46.00	-9.18	peak			
5		733.2500	9.77	26.15	35.92	46.00	-10.08	peak			
6	*	898.1500	13.16	28.56	41.72	46.00	-4.28	peak			

RESULT: PASS

Note: 1. Factor=Antenna Factor + Cable loss, Margin=Measurement-Limit.

2. The "Factor" value can be calculated automatically by software of measurement system.

RADIATED EMISSION ABOVE 1GHZ
(Worst modulation: GFSK)
FOR BR/EDR

RADIATED EMISSION TEST- (ABOVE 1GHZ)-LOW CHANNEL-HORIZONTAL

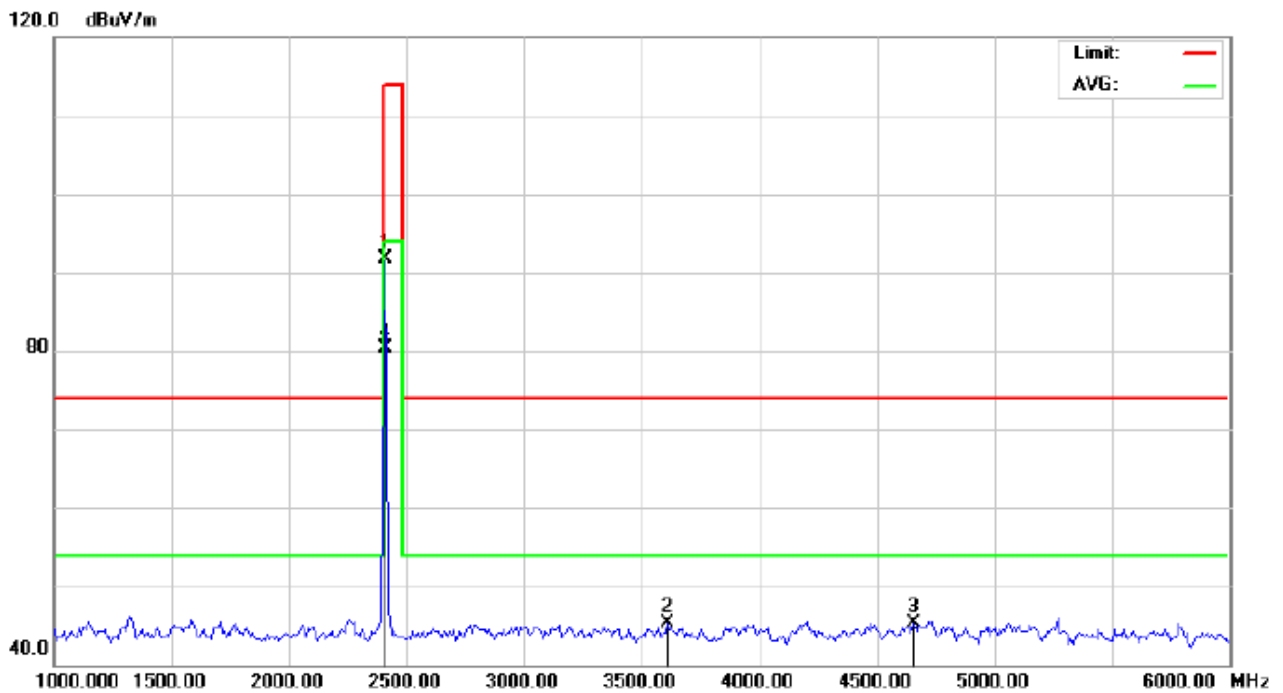

Site: Conduction Polarization: *Horizontal* Temperature: 26
Limit: FCC Class B 3M Radiation above 1GHZ(PK)- Power: Humidity: 60 %
EUT: Bluetooth Speaker Distance: 3m
M/N: BT064B
Mode: Low Channel TX
Note:

No.	Mk	Freq.	Reading	Factor	Measurement	Limit	Over	Detector	Antenna Height	Table Degree	Comment
		MHz	dBuV	dBuV/m	dBuV/m	dBuV/m	dB		cm	degree	
1		2402.000	101.29	-9.68	91.61	114.00	-22.39	peak			
2		3608.333	52.44	-7.22	45.22	74.00	-28.78	peak			
3		4658.333	47.99	-2.70	45.29	74.00	-28.71	peak			
4	*	2402.000	89.90	-9.68	80.22	94.00	-13.78	AVG	100	248	

RESULT: PASS

RADIATED EMISSION TEST- (ABOVE 1GHZ)-LOW CHANNEL- VERTICAL

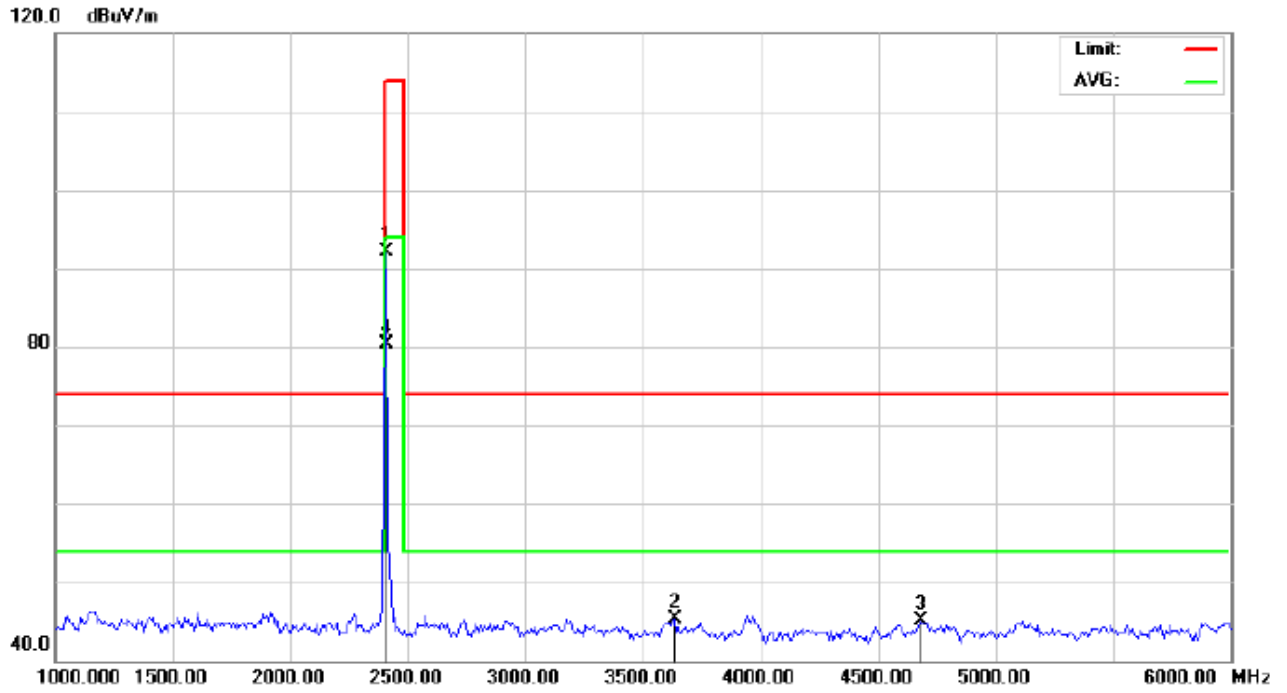

Site: Conduction Polarization: **Vertical** Temperature: 26
Limit: FCC Class B 3M Radiation above 1GHZ(PK)- Power: Humidity: 60 %
EUT: Bluetooth Speaker Distance: 3m
M/N: BT064B
Mode: Low Channel TX
Note:

No.	Mk	Freq.	Reading	Factor	Measurement	Limit	Over	Detector	Antenna Height	Table Degree	Comment
		MHz	dBuV	dBuV/m	dBuV/m	dBuV/m	dB		cm	degree	
1		2402.000	101.71	-9.68	92.03	114.00	-21.97	peak			
2		3633.333	52.41	-7.07	45.34	74.00	-28.66	peak			
3		4683.333	47.71	-2.63	45.08	74.00	-28.92	peak			
4	*	2402.000	90.04	-9.68	80.36	94.00	-13.64	AVG	100	188	

RESULT: PASS

RADIATED EMISSION TEST- (ABOVE 1GHZ)-MIDDLE CHANNEL-HORIZONTAL

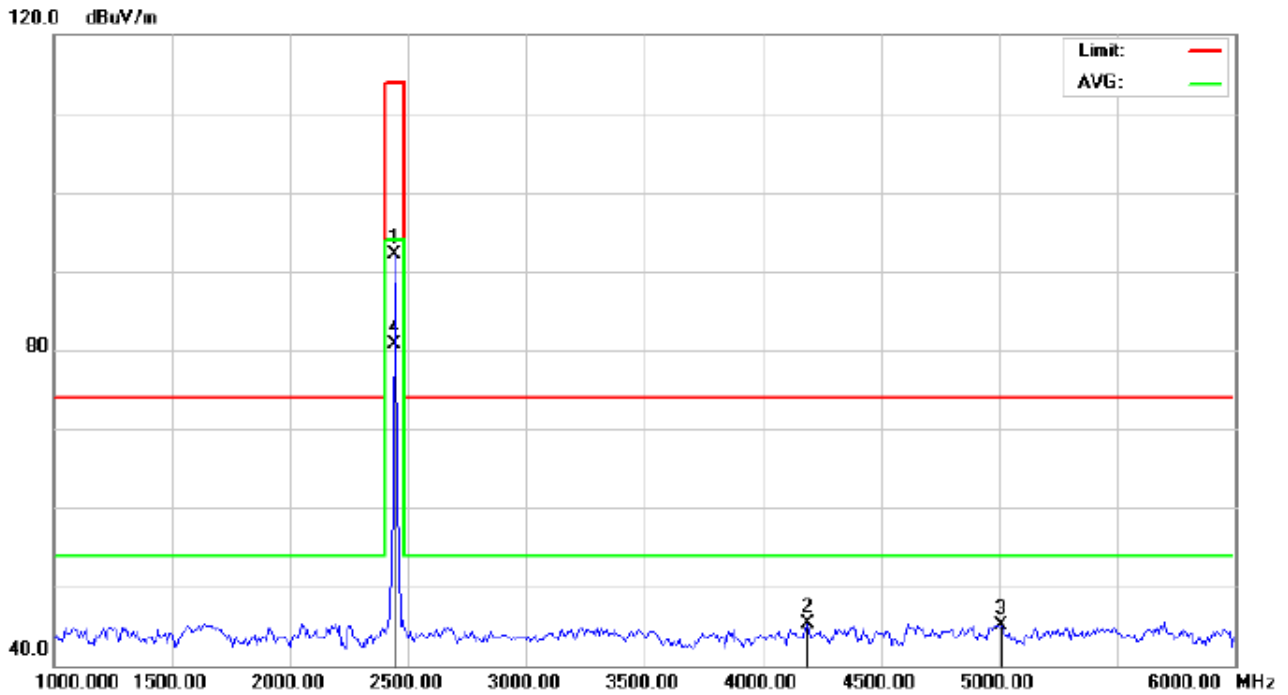

Site: Conduction Polarization: *Horizontal* Temperature: 26
Limit: FCC Class B 3M Radiation above 1GHZ(PK)- Power: Humidity: 60 %
EUT: Bluetooth Speaker Distance: 3m
M/N: BT064B
Mode: Middle Channel TX
Note:

No.	Mk	Freq.	Reading	Factor	Measurement	Limit	Over	Detector	Antenna Height	Table Degree	Comment
		MHz	dBuV	dBuV/m	dBuV/m	dBuV/m	dB		cm	degree	
1		2441.000	101.77	-9.63	92.14	114.00	-21.86	peak			
2		4191.667	49.40	-4.16	45.24	74.00	-28.76	peak			
3		5008.333	46.96	-1.80	45.16	74.00	-28.84	peak			
4	*	2441.000	90.42	-9.63	80.79	94.00	-13.21	AVG	100	251	

RESULT: PASS

RADIATED EMISSION TEST- (ABOVE 1GHZ)-MIDDLE CHANNEL- VERTICAL

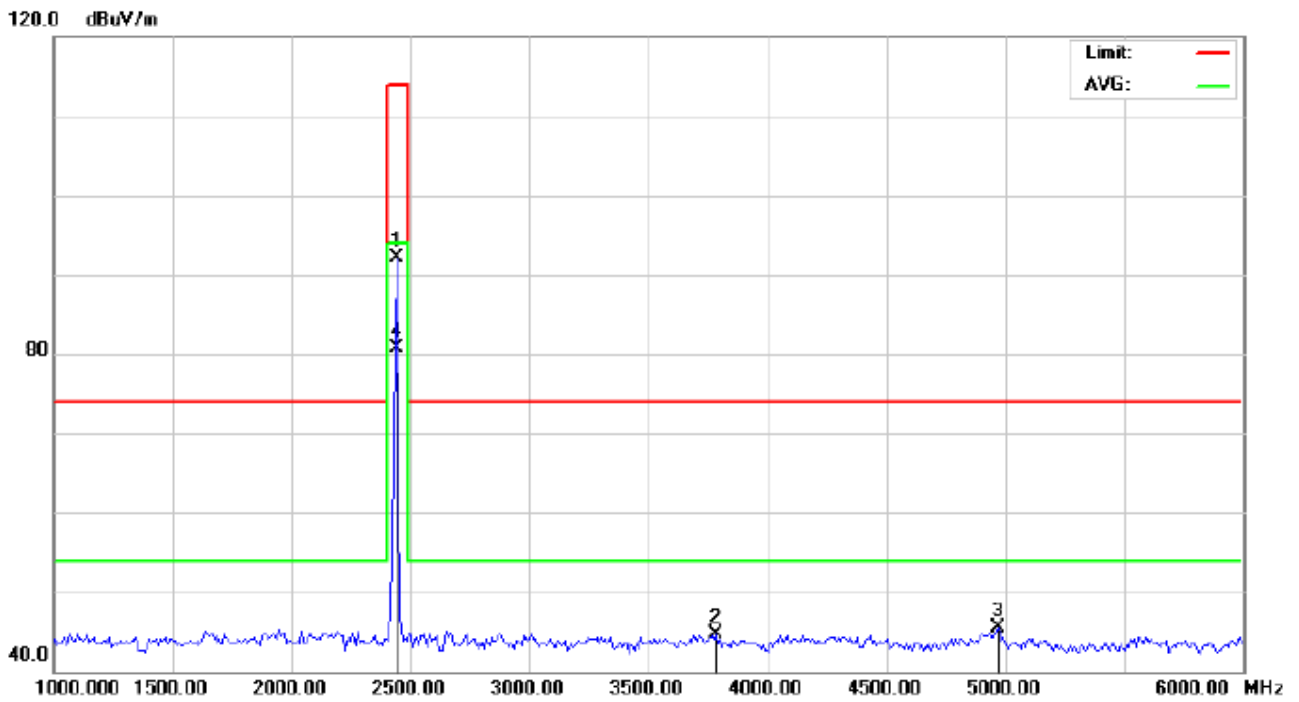

Site: Conduction Polarization: *Vertical* Temperature: 26
Limit: FCC Class B 3M Radiation above 1GHZ(PK)- Power: Humidity: 60 %
EUT: Bluetooth Speaker Distance: 3m
M/N: BT064B
Mode: Middle Channel TX
Note:

No.	Mk	Freq.	Reading	Factor	Measurement	Limit	Over	Detector	Antenna Height	Table Degree	Comment
		MHz	dBuV	dBuV/m	dBuV/m	dBuV/m	dB		cm	degree	
1		2441.000	101.69	-9.63	92.06	114.00	-21.94	peak			
2		3783.333	50.83	-6.14	44.69	74.00	-29.31	peak			
3		4966.667	47.39	-1.89	45.50	74.00	-28.50	peak			
4	*	2441.000	90.31	-9.63	80.68	94.00	-13.32	AVG	100	185	

RESULT: PASS

RADIATED EMISSION TEST- (ABOVE 1GHZ)-HIGH CHANNEL-HORIZONTAL

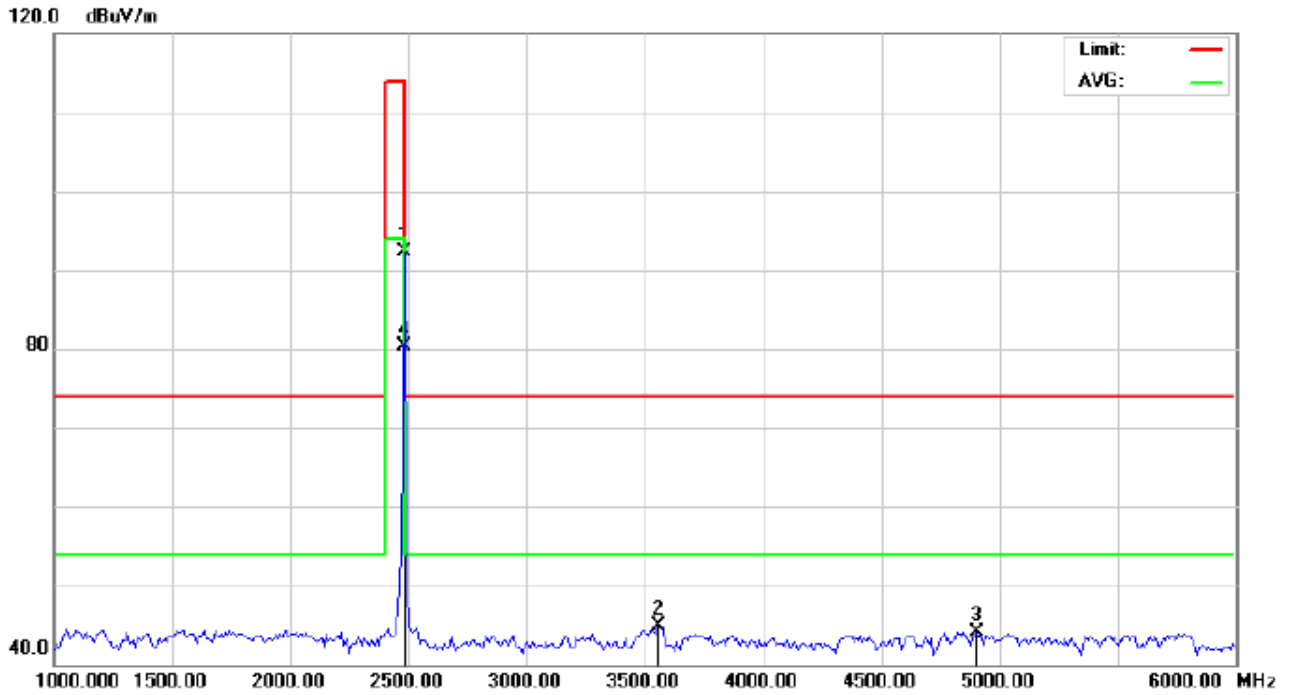

Site: Conduction Polarization: *Horizontal* Temperature: 26
Limit: FCC Class B 3M Radiation above 1GHZ(PK)- Power: Humidity: 60 %
EUT: Bluetooth Speaker Distance: 3m
M/N: BT064B
Mode: High Channel TX
Note:

No.	Mk	Freq.	Reading	Factor	Measurement	Limit	Over	Detector	Antenna Height	Table Degree	Comment
		MHz	dBuV	dBuV/m	dBuV/m	dBuV/m	dB		cm	degree	
1		2480.000	101.84	-9.59	92.25	114.00	-21.75	peak			
2		3558.333	52.43	-7.53	44.90	74.00	-29.10	peak			
3		4900.000	46.18	-2.06	44.12	74.00	-29.88	peak			
4	*	2480.000	89.92	-9.59	80.33	94.00	-13.67	AVG	100	246	

RESULT: PASS

RADIATED EMISSION TEST- (ABOVE 1GHZ)-HIGH CHANNEL- VERTICAL

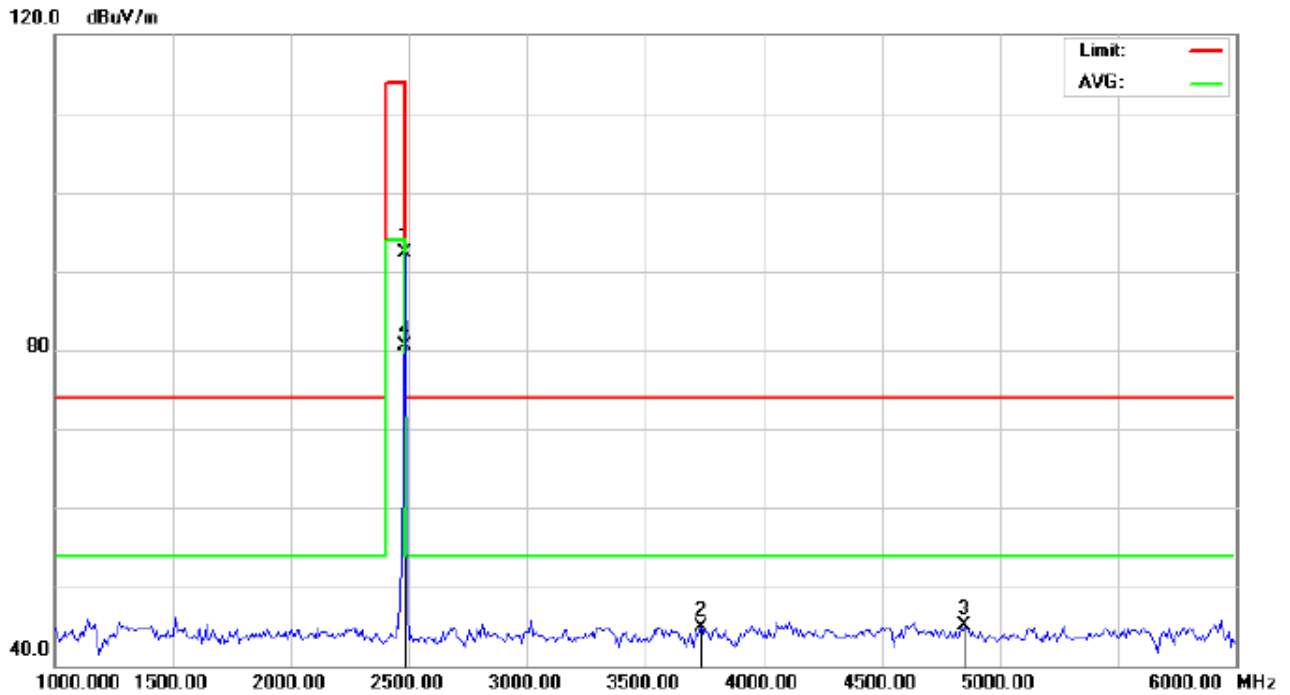

Site: Conduction Polarization: *Vertical* Temperature: 26
 Limit: FCC Class B 3M Radiation above 1GHZ(PK)- Power: Humidity: 60 %
 EUT: Bluetooth Speaker Distance: 3m
 M/N: BT064B
 Mode: High Channel TX
 Note:

No.	Mk	Freq.	Reading	Factor	Measurement	Limit	Over	Detector	Antenna Height	Table Degree	Comment
		MHz	dBuV	dBuV/m	dBuV/m	dBuV/m	dB		cm	degree	
1		2480.000	101.89	-9.59	92.30	114.00	-21.70	peak			
2		3733.333	51.45	-6.45	45.00	74.00	-29.00	peak			
3		4850.000	47.20	-2.19	45.01	74.00	-28.99	peak			
4	*	2480.000	90.01	-9.59	80.42	94.00	-13.58	AVG	100	192	

RESULT: PASS

Note: 6~25GHz at least have 20dB margin. No recording in the test report.

Factor=Antenna Factor + Cable loss - Amplifier gain, Margin=Measurement-Limit.

The "Factor" value can be calculated automatically by software of measurement system.

Field strength of the fundamental signal(GFSK):

Peak value

Frequency	Reading Level	Factor	Measurement	Limit	Over	Antenna
(MHz)	(dBuv)	(dB/m)	(dBuv/m)	(dBuv/m)	(dB)	Polarization
2402	101.29	-9.68	91.61	114.00	-22.39	Horizontal
2402	101.71	-9.68	92.03	114.00	-21.97	Vertical
2441	101.77	-9.63	92.14	114.00	-21.86	Horizontal
2441	101.69	-9.63	92.06	114.00	-21.94	Vertical
2480	101.84	-9.59	92.25	114.00	-21.75	Horizontal
2480	101.89	-9.59	92.30	114.00	-21.70	Vertical

Average value

Frequency	Reading Level	Factor	Measurement	Limit	Over	Antenna
(MHz)	(dBuv)	(dB/m)	(dBuv/m)	(dBuv/m)	(dB)	Polarization
2402	89.90	-9.68	80.22	94.00	-13.78	Horizontal
2402	90.04	-9.68	80.36	94.00	-13.64	Vertical
2441	90.42	-9.63	80.79	94.00	-13.21	Horizontal
2441	90.31	-9.63	80.68	94.00	-13.32	Vertical
2480	89.92	-9.59	80.33	94.00	-13.67	Horizontal
2480	90.01	-9.59	80.42	94.00	-13.58	Vertical

Field strength of the fundamental signal(π /4DQPSK):

Peak value

Frequency	Reading Level	Factor	Measurement	Limit	Over	Antenna
(MHz)	(dBuv)	(dB/m)	(dBuv/m)	(dBuv/m)	(dB)	Polarization
2402	101.22	-9.68	91.54	114.00	-22.46	Horizontal
2402	101.34	-9.68	91.66	114.00	-22.34	Vertical
2441	101.57	-9.68	91.89	114.00	-22.11	Horizontal
2441	101.61	-9.68	91.93	114.00	-22.07	Vertical
2480	101.76	-9.63	92.13	114.00	-21.87	Horizontal
2480	101.67	-9.63	92.04	114.00	-21.96	Vertical

Average value

Frequency	Reading Level	Factor	Measurement	Limit	Over	Antenna
(MHz)	(dBuv)	(dB/m)	(dBuv/m)	(dBuv/m)	(dB)	Polarization
2402	89.77	-9.63	80.14	94.00	-13.86	Horizontal
2402	89.84	-9.63	80.21	94.00	-13.79	Vertical
2441	-90.15	-9.59	80.56	94.00	-13.44	Horizontal
2441	-90.26	-9.59	80.67	94.00	-13.33	Vertical
2480	-90.32	-9.59	80.73	94.00	-13.27	Horizontal
2480	-90.48	-9.59	80.89	94.00	-13.11	Vertical

Field strength of the fundamental signal(8DPSK):

Peak value

Frequency	Reading Level	Factor	Measurement	Limit	Over	Antenna
(MHz)	(dBuv)	(dB/m)	(dBuv/m)	(dBuv/m)	(dB)	Polarization
2402	100.47	-9.68	90.79	114.00	-23.21	Horizontal
2402	100.33	-9.68	90.65	114.00	-23.35	Vertical
2441	100.75	-9.68	91.07	114.00	-22.93	Horizontal
2441	100.69	-9.68	91.01	114.00	-22.99	Vertical
2480	101.5	-9.63	91.87	114.00	-22.13	Horizontal
2480	101.39	-9.63	91.76	114.00	-22.24	Vertical

Average value

Frequency	Reading Level	Factor	Measurement	Limit	Over	Antenna
(MHz)	(dBuv)	(dB/m)	(dBuv/m)	(dBuv/m)	(dB)	Polarization
2402	87.89	-9.63	78.26	94.00	-15.74	Horizontal
2402	87.8	-9.63	78.17	94.00	-15.83	Vertical
2441	-88.95	-9.59	79.36	94.00	-14.64	Horizontal
2441	-88.84	-9.59	79.25	94.00	-14.75	Vertical
2480	-89.35	-9.59	79.76	94.00	-14.24	Horizontal
2480	-89.45	-9.59	79.86	94.00	-14.14	Vertical

10. BAND EDGE EMISSION

10.1. MEASUREMENT PROCEDURE

- 1.The EUT operates at hopping-off test mode. The lowest or highest channels are tested to verify the largest transmission and spurious emissions power at the continuous transmission mode.
- 2.Max hold the trace of the setp 1, and the EUT operates at hopping-on test mode to verify the largest spurious emissions power.
- 3.Set the spectrum analyzer in the following setting in order to capture the lower and upper band-edges of the emission.

10.2 TEST SETUP

RADIATED EMISSION TEST SETUP

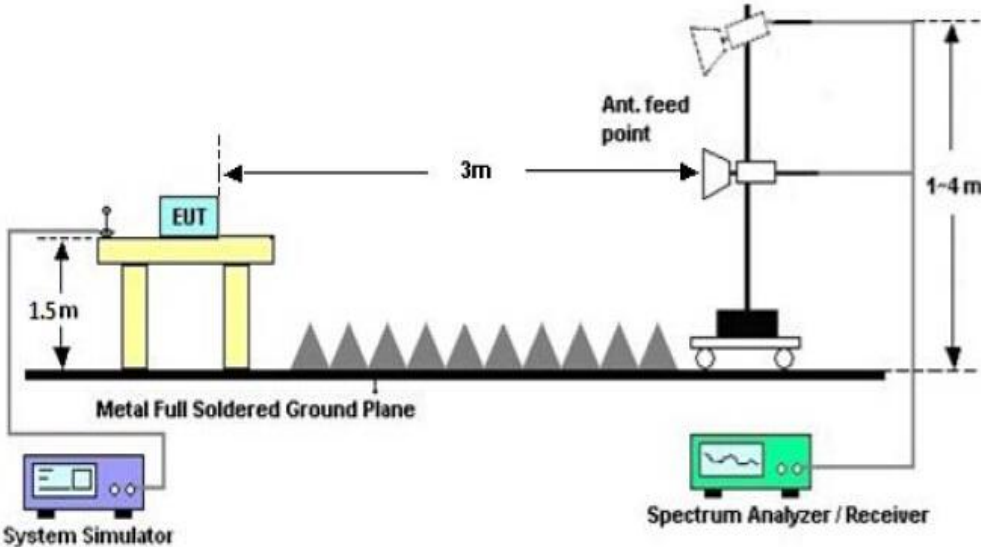

TEST PLOT OF BAND EDGE FOR LOW CHANNEL –Vertical

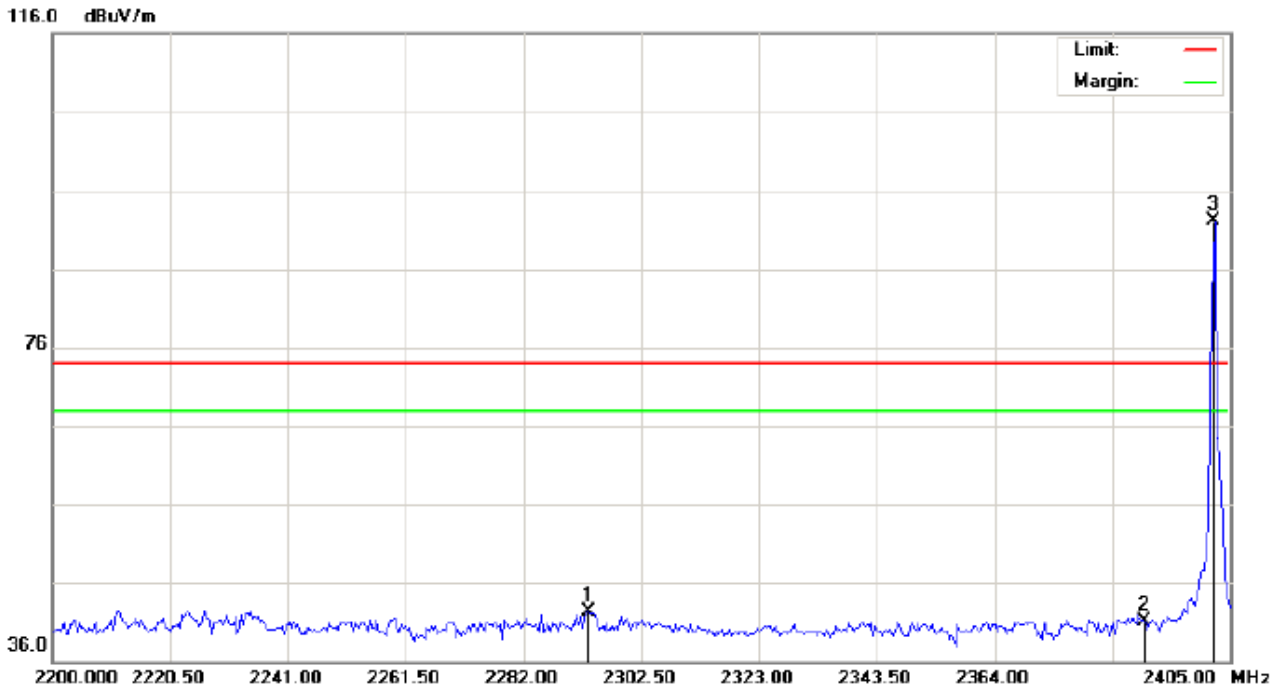

Site: site #1
 Limit: FCC Class B 3M Radiation above 1GHZ(PK)
 EUT: Bluetooth Speaker
 M/N: BT064B
 Mode: Low Channel TX
 Note:

Polarization: *Vertical*
 Power:
 Distance:

Temperature: 26
 Humidity: 60 %

No.	Mk	Freq.	Reading	Factor	Measurement	Limit	Over	Detector	Antenna Height	Table Degree	Comment
		MHz	dBuV	dB/m	dBuV/m	dBuV/m	dB		cm	degree	
1		2293.275	32.15	10.20	42.35	74.00	-31.65	peak			
2		2390.000	30.85	10.31	41.16	74.00	-32.84	peak			
3	*	2402.000	81.76	10.32	92.08	74.00	18.08	peak			

TEST PLOT OF BAND EDGE FOR HIGH CHANNEL -Horizontal

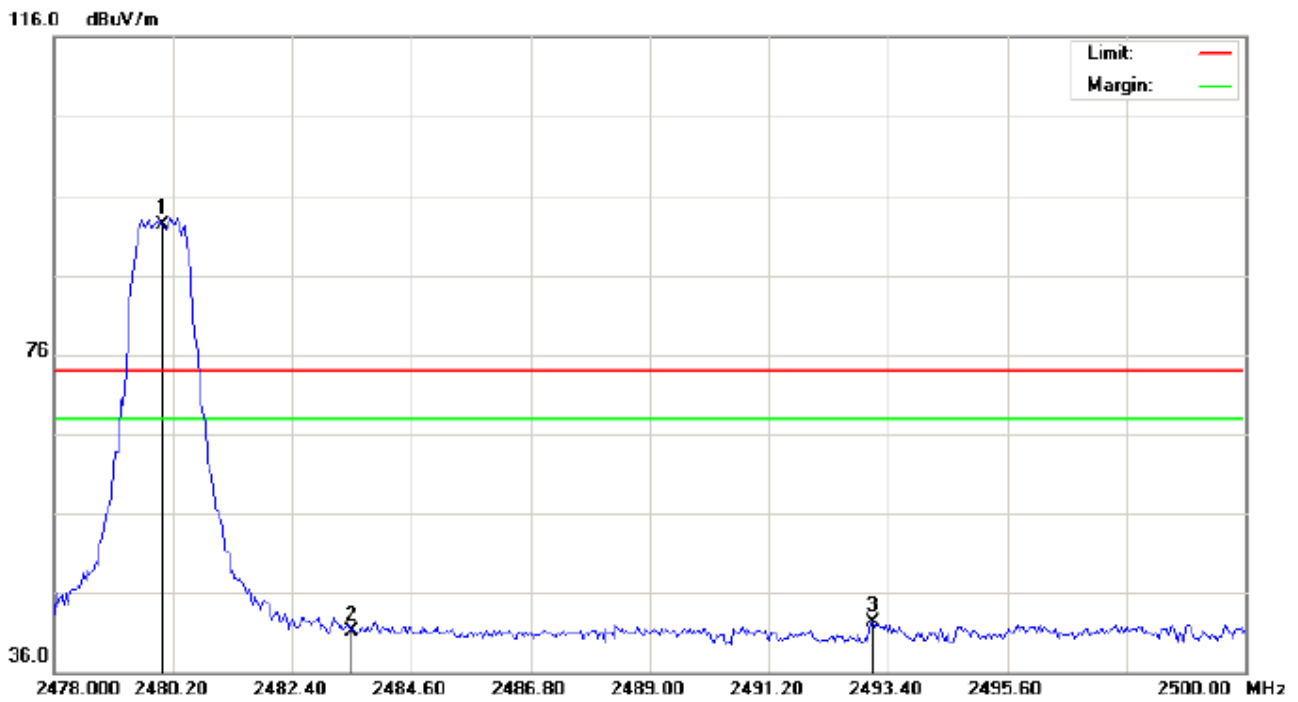

Site: site #1 Polarization: *Horizontal* Temperature: 26
Limit: FCC Class B 3M Radiation above 1GHZ(PK) Power: Humidity: 60 %
EUT: Bluetooth Speaker Distance:
M/N: BT064B
Mode: High Channel TX
Note:

No.	Mk	Freq.	Reading	Factor	Measurement	Limit	Over	Detector	Antenna	Table	Comment
		MHz	dBuV	dB/m	dBuV/m	dBuV/m	dB		Height	Degree	
									cm	degree	
1	*	2480.000	81.96	10.41	92.37	74.00	18.37	peak			
2		2483.500	30.75	10.41	41.16	74.00	-32.84	peak			
3		2493.107	31.80	10.42	42.22	74.00	-31.78	peak			

TEST PLOT OF BAND EDGE FOR HIGH CHANNEL-Vertical

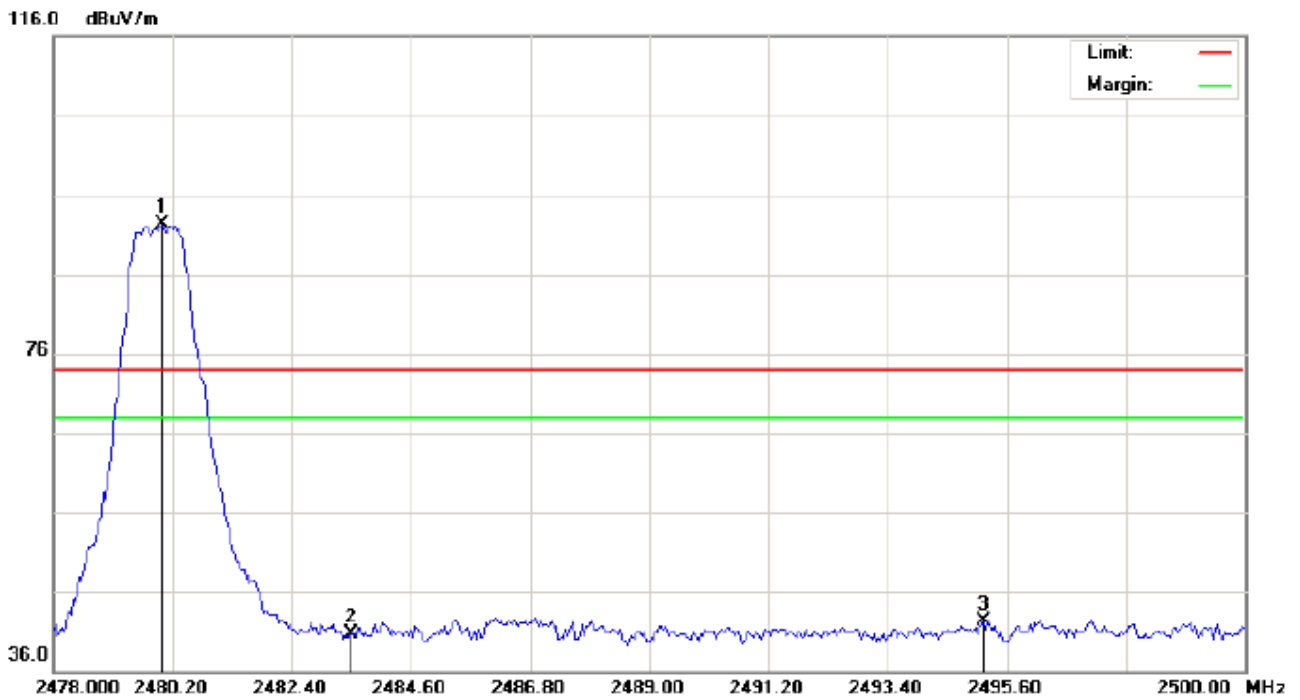

Site: site #1 Polarization: *Vertical* Temperature: 26
 Limit: FCC Class B 3M Radiation above 1GHZ(PK) Power: Humidity: 60 %
 EUT: Bluetooth Speaker Distance:
 M/N: BT064B
 Mode: High Channel TX
 Note:

No.	Mk	Freq.	Reading	Factor	Measurement	Limit	Over	Detector	Antenna	Table	Comment
		MHz	dBuV	dB/m	dBuV/m	dBuV/m	dB		Height	Degree	
									cm	degree	
1	*	2480.000	81.85	10.41	92.26	74.00	18.26	peak			
2		2483.500	30.37	10.41	40.78	74.00	-33.22	peak			
3		2495.160	31.85	10.42	42.27	74.00	-31.73	peak			

RESULT: PASS

Note: The other modes radiation emission have enough 20dB margin.

Factor=Antenna Factor + Cable loss - Amplifier gain, Over=Measure-Limit.

The "Factor" value can be calculated automatically by software of measurement system.

Hopping on mode and Hopping off mode have been tested, but only worst case reported.

11. 20DB BANDWIDTH

11.1. MEASUREMENT PROCEDURE

1. Connect EUT RF output port to the Spectrum Analyzer through an RF attenuator
2. Set the EUT Work on the top, the middle and the bottom operation frequency individually.
3. Set Span = approximately 2 to 3 times the 20 dB bandwidth, centered on a hopping channel
RBW \geq 1% of the 20 dB bandwidth, VBW \geq RBW; Sweep = auto; Detector function = peak
4. Set SPA Trace 1 Max hold, then View.

11.2. TEST SET-UP

(BLOCK DIAGRAM OF CONFIGURATION)

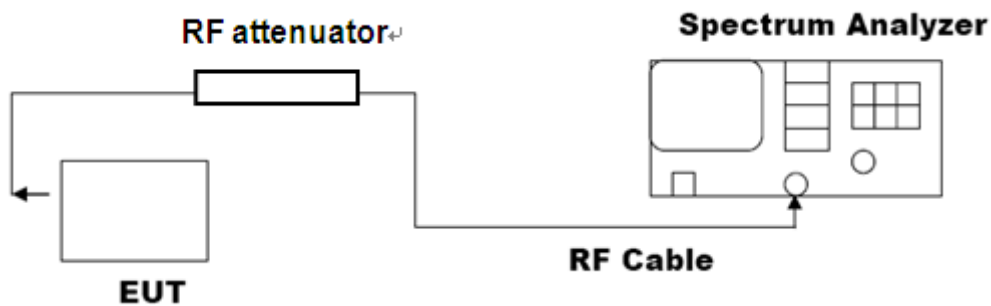

Note: The EUT has been used temporary antenna connector for testing.

11.3. LIMITS AND MEASUREMENT RESULTS

BLUETOOTH 1MBPS LIMITS AND MEASUREMENT RESULT			
Applicable Limits	Measurement Result		
	Test Data (MHz)		Criteria
N/A	Low Channel	1.096	PASS
	Middle Channel	1.049	PASS
	High Channel	1.106	PASS

TEST PLOT OF BANDWIDTH FOR LOW CHANNEL

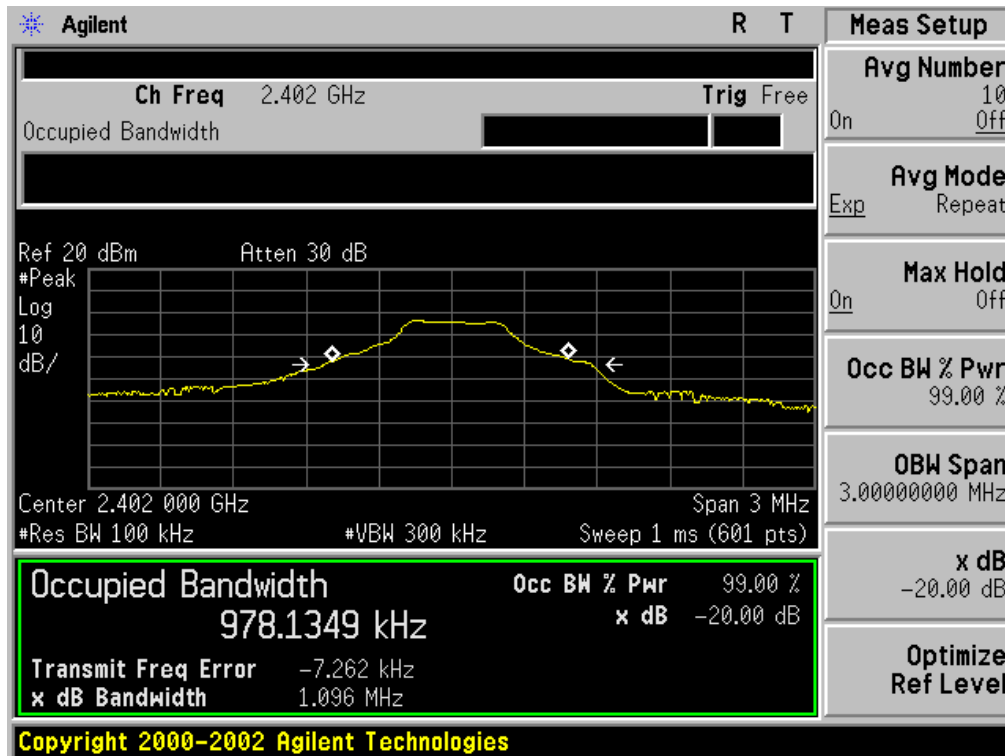

TEST PLOT OF BANDWIDTH FOR MIDDLE CHANNEL

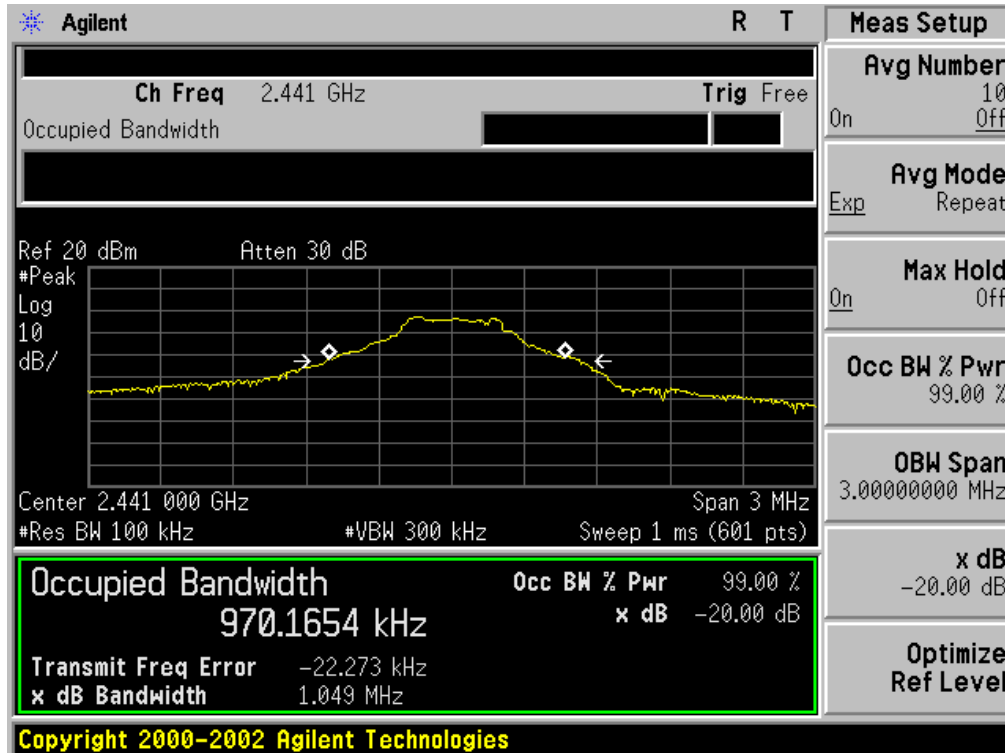

TEST PLOT OF BANDWIDTH FOR HIGH CHANNEL

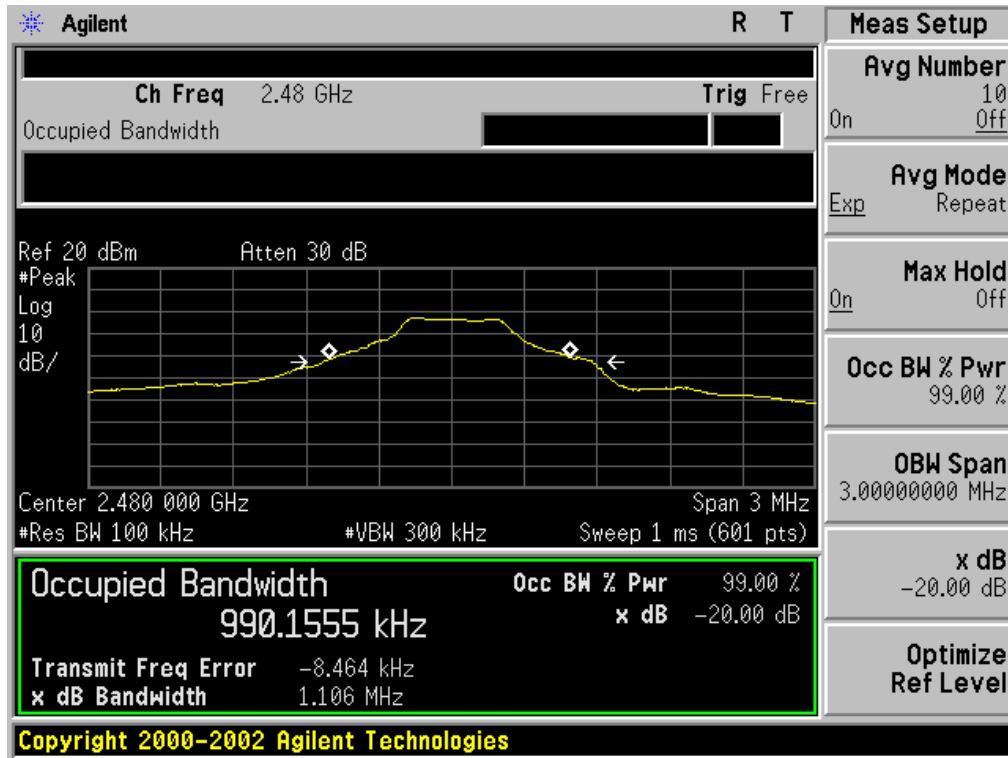

BLUETOOTH 2MBPS LIMITS AND MEASUREMENT RESULT			
Applicable Limits	Measurement Result		
	Test Data (MHz)		Criteria
N/A	Low Channel	1.368	PASS
	Middle Channel	1.373	PASS
	High Channel	1.372	PASS

TEST PLOT OF BANDWIDTH FOR LOW CHANNEL

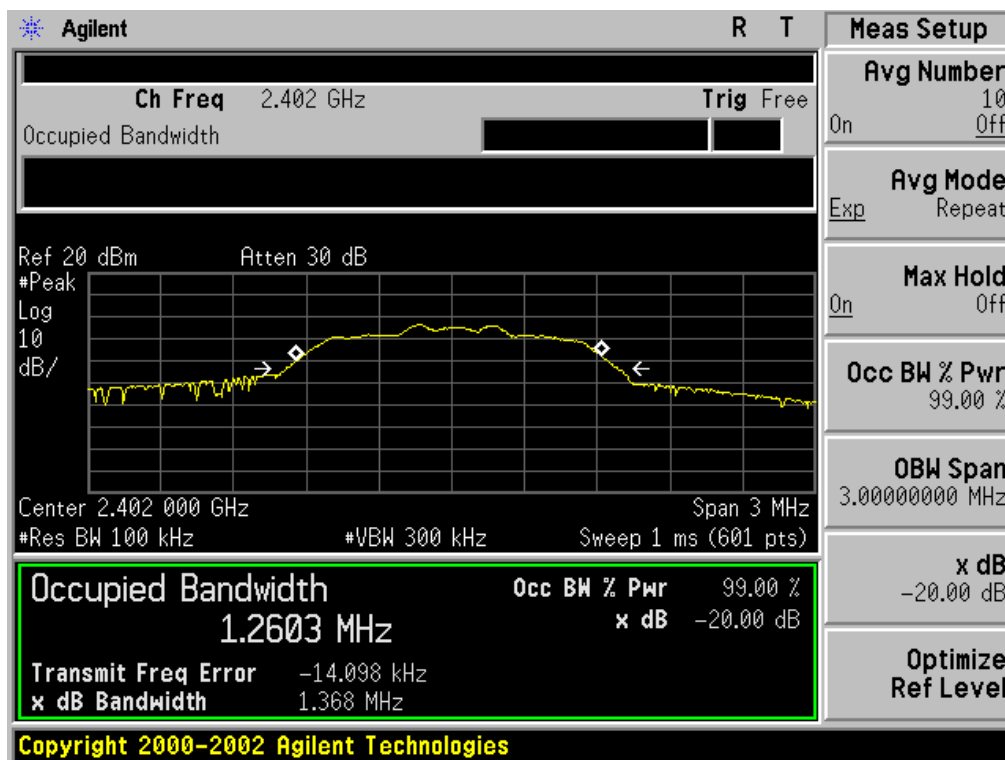

TEST PLOT OF BANDWIDTH FOR MIDDLE CHANNEL

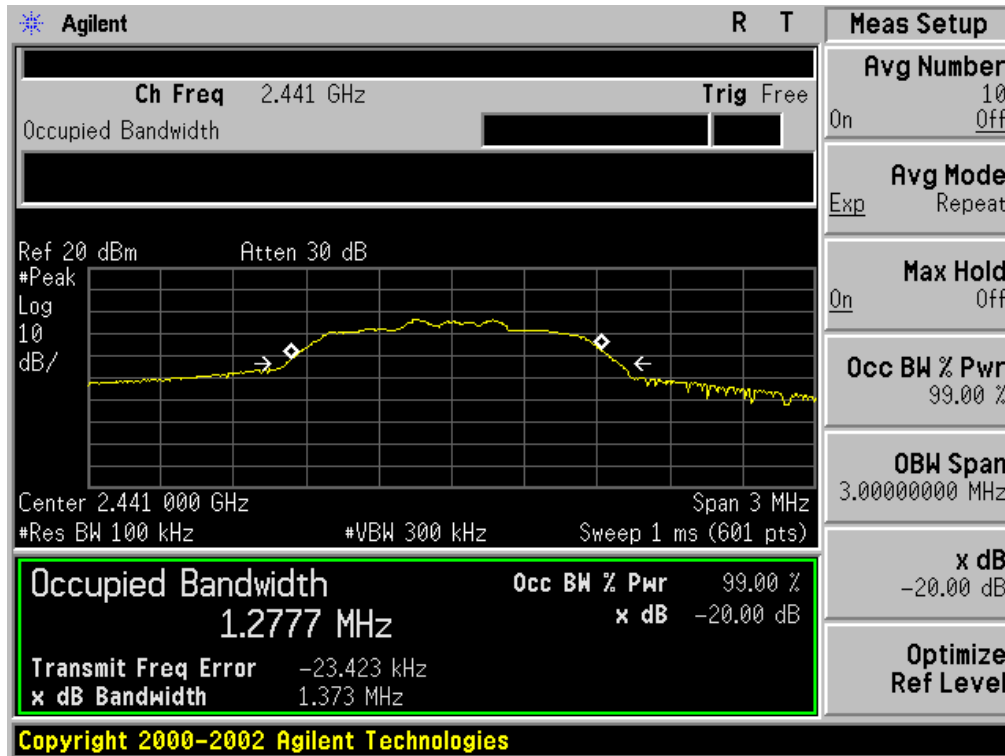

TEST PLOT OF BANDWIDTH FOR HIGH CHANNEL

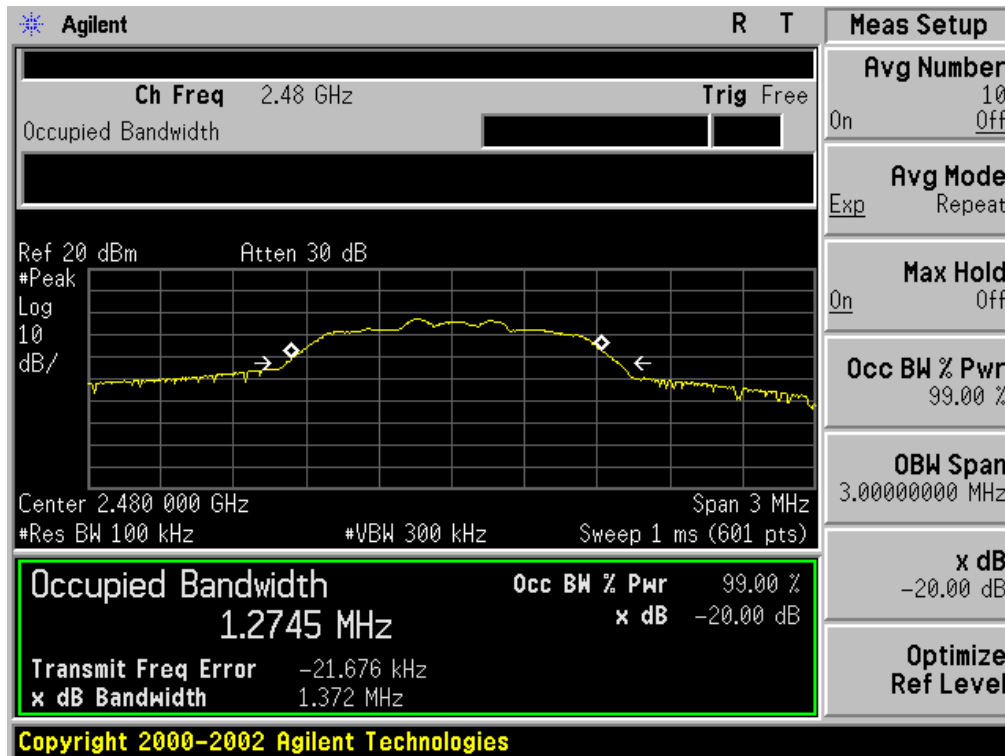

BLUETOOTH 3MBPS LIMITS AND MEASUREMENT RESULT			
Applicable Limits	Measurement Result		
	Test Data (MHz)		Criteria
N/A	Low Channel	1.370	PASS
	Middle Channel	1.370	PASS
	High Channel	1.366	PASS

TEST PLOT OF BANDWIDTH FOR LOW CHANNEL

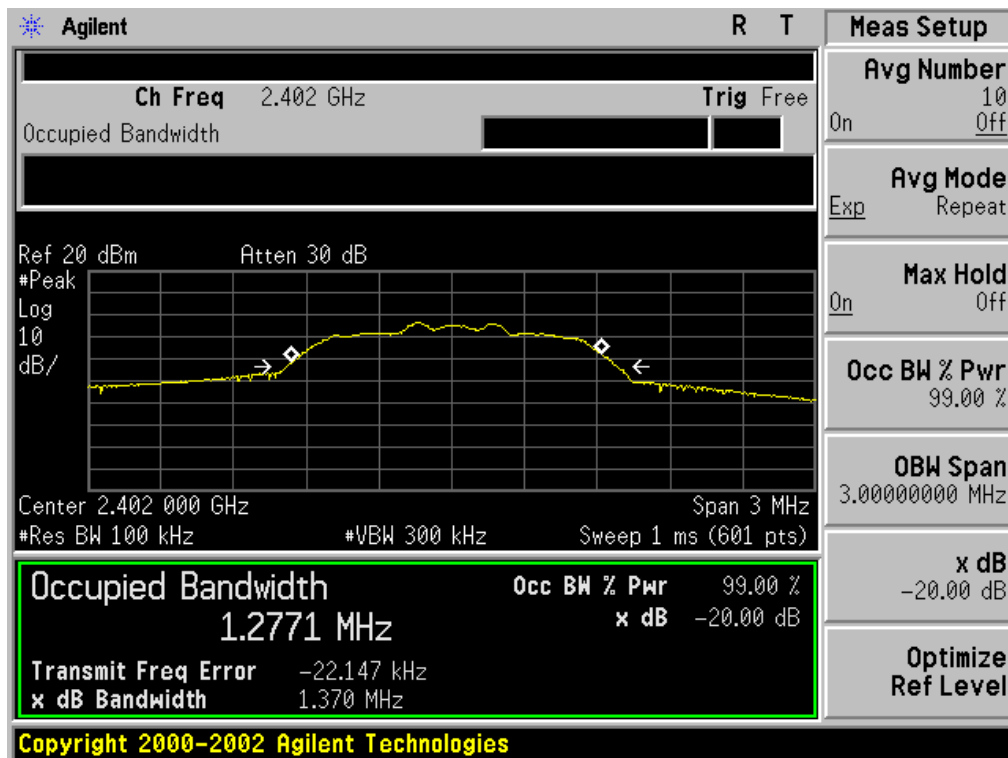

TEST PLOT OF BANDWIDTH FOR MIDDLE CHANNEL

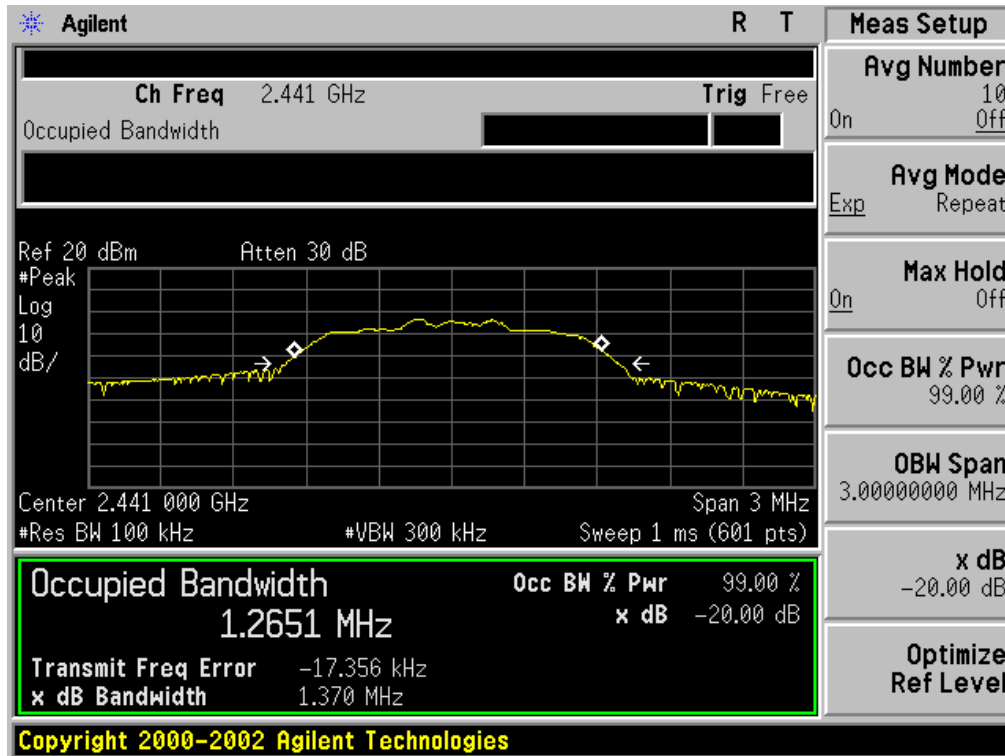

TEST PLOT OF BANDWIDTH FOR HIGH CHANNEL

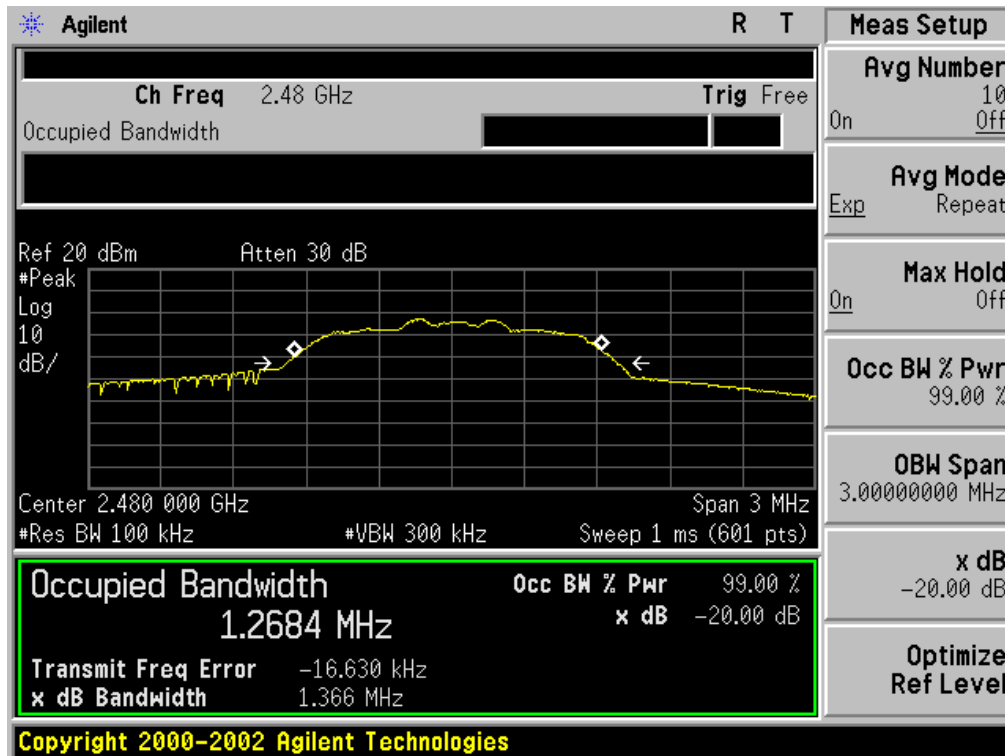

12. FCC LINE CONDUCTED EMISSION TEST

12.1. LIMITS OF LINE CONDUCTED EMISSION TEST

Frequency	Maximum RF Line Voltage	
	Q.P.(dBuV)	Average(dBuV)
150kHz~500kHz	66-56	56-46
500kHz~5MHz	56	46
5MHz~30MHz	60	50

Note:

1. The lower limit shall apply at the transition frequency.
2. The limit decreases linearly with the logarithm of the frequency in the range 0.15 MHz to 0.50 MHz.

12.2. BLOCK DIAGRAM OF LINE CONDUCTED EMISSION TEST

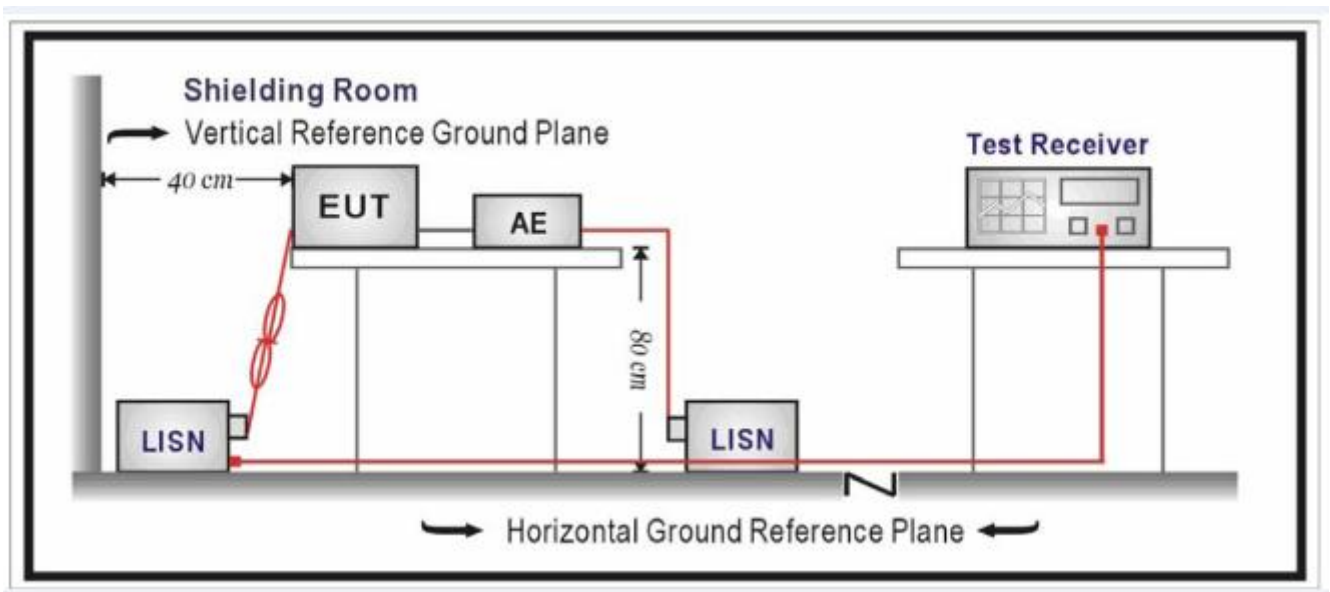

12.3. PRELIMINARY PROCEDURE OF LINE CONDUCTED EMISSION TEST

1. The equipment was set up as per the test configuration to simulate typical actual usage per the user's manual. When the EUT is a tabletop system, a wooden table with a height of 0.8 meters is used and is placed on the ground plane as per ANSI C63.4 (see Test Facility for the dimensions of the ground plane used). When the EUT is a floor-standing equipment, it is placed on the ground plane which has a 3-12 mm non-conductive covering to insulate the EUT from the ground plane.
2. Support equipment, if needed, was placed as per ANSI C63.4.
3. All I/O cables were positioned to simulate typical actual usage as per ANSI C63.4.
4. All support equipments received AC120V/60Hz power from a LISN, if any.
5. The EUT received DC charging voltage by PC or Adapter
6. The test program was started. Emissions were measured on each current carrying line of the EUT using a spectrum Analyzer / Receiver connected to the LISN powering the EUT. The LISN has two monitoring points: Line 1 (Hot Side) and Line 2 (Neutral Side). Two scans were taken: one with Line 1 connected to Analyzer / Receiver and Line 2 connected to a 50 ohm load; the second scan had Line 1 connected to a 50 ohm load and Line 2 connected to the Analyzer / Receiver.
7. Analyzer / Receiver scanned from 150 kHz to 30MHz for emissions in each of the test modes.
8. During the above scans, the emissions were maximized by cable manipulation.
9. The test mode(s) were scanned during the preliminary test.

Then, the EUT configuration and cable configuration of the above highest emission level were recorded for reference of final testing.

12.4. FINAL PROCEDURE OF LINE CONDUCTED EMISSION TEST

- EUT and support equipment was set up on the test bench as per step 2 of the preliminary test.
2. A scan was taken on both power lines, Line 1 and Line 2, recording at least the six highest emissions. Emission frequency and amplitude were recorded into a computer in which correction factors were used to calculate the emission level and compare reading to the applicable limit. If EUT emission level was less -2dB to the A.V. limit in Peak mode, then the emission signal was re-checked using Q.P and Average detector.
3. The test data of the worst case condition(s) was reported on the Summary Data page.

12.5. TEST RESULT OF LINE CONDUCTED EMISSION TEST

Note: The below data was tested by adapter (worst case)

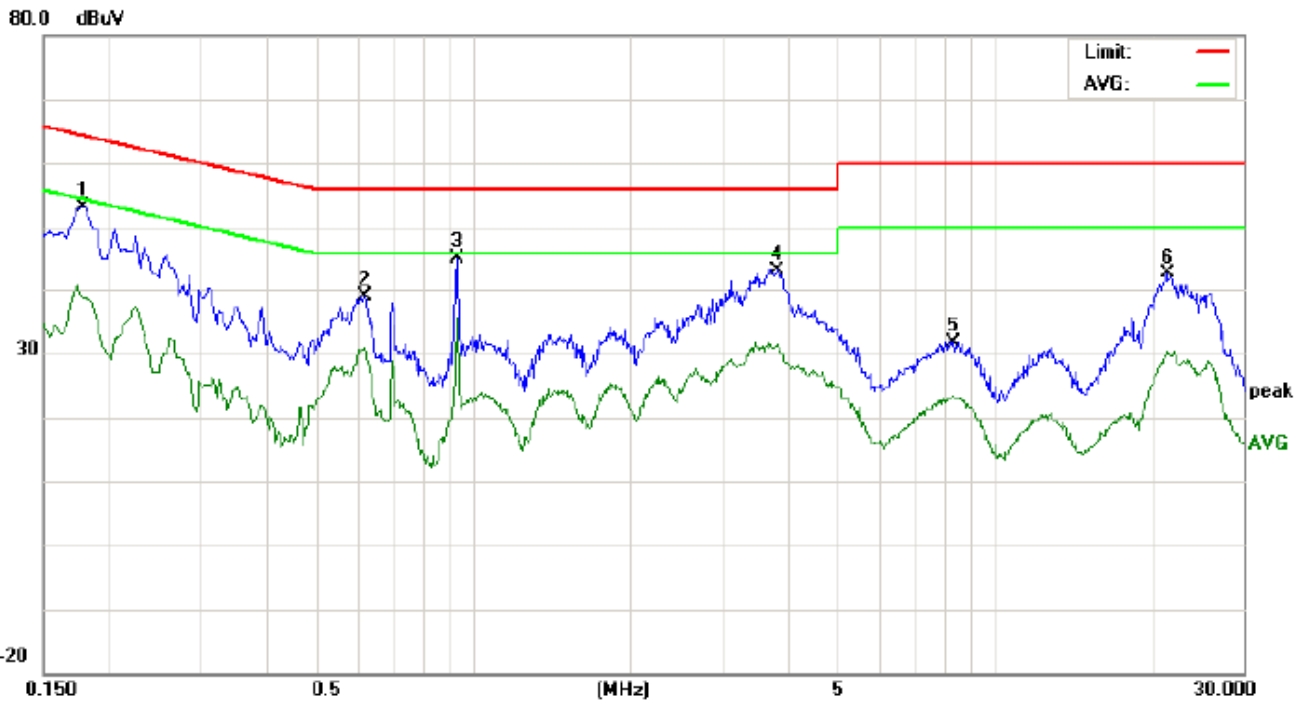

Site: Conduction Phase: *L1* Temperature: 24.5
Limit: FCC Class B Conduction(QP) Power: Humidity: 52.4 %
EUT: Bluetooth Speaker
M/N: BT064B
Mode: BT Link with charging
Note:

No.	Freq. (MHz)	Reading_Level (dBuV)			Correct Factor (dB)	Measurement (dBuV)			Limit (dBuV)		Margin (dB)		P/F	Comment
		Peak	QP	AVG		Peak	QP	AVG	QP	AVG	QP	AVG		
1	0.1780	42.89		28.44	10.19	53.08		38.63	64.57	54.57	-11.49	-15.94	P	
2	0.6180	28.59		20.52	10.32	38.91		30.84	56.00	46.00	-17.09	-15.16	P	
3	0.9300	34.81		24.83	10.40	45.21		35.23	56.00	46.00	-10.79	-10.77	P	
4	3.8300	32.70		20.79	10.46	43.16		31.25	56.00	46.00	-12.84	-14.75	P	
5	8.3499	21.33		12.95	10.34	31.67		23.29	60.00	50.00	-28.33	-26.71	P	
6	21.4340	32.60		19.69	10.13	42.73		29.82	60.00	50.00	-17.27	-20.18	P	

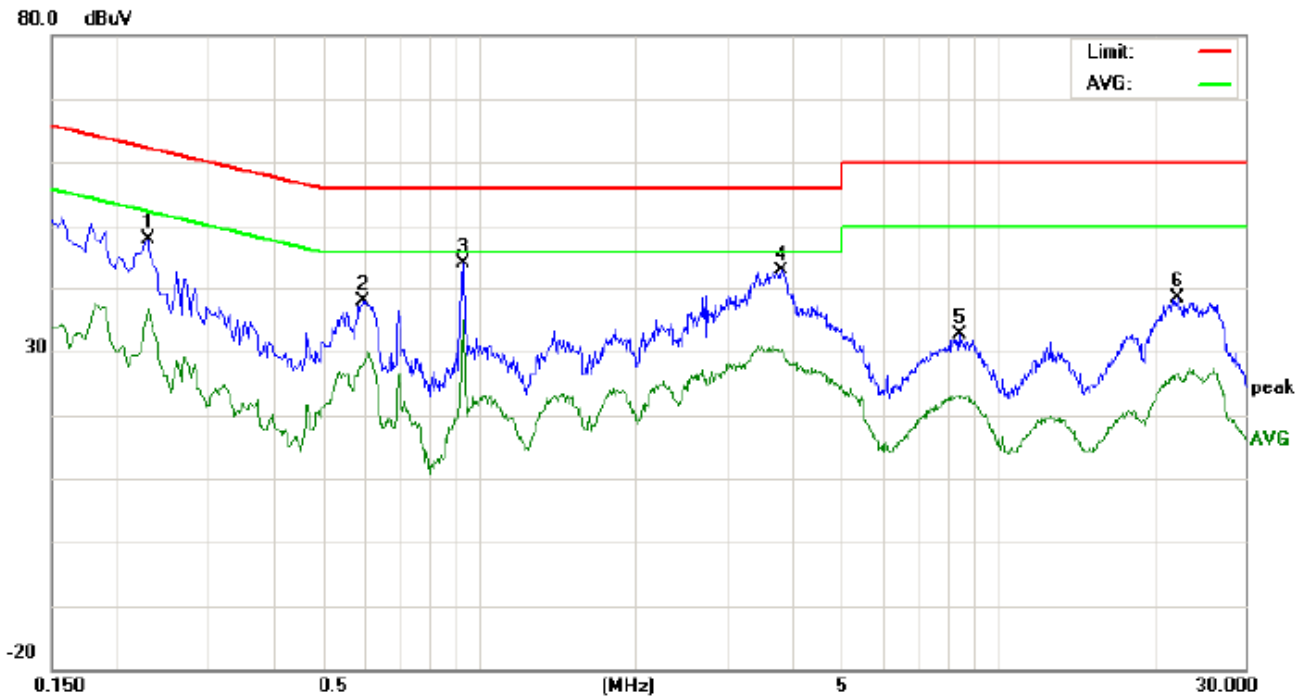

Site: Conduction Phase: **N** Temperature: 24.5
 Limit: FCC Class B Conduction(QP) Power: Humidity: 52.4 %
 EUT: Bluetooth Speaker
 M/N: BT064B
 Mode: BT Link with charging
 Note:

No.	Freq. (MHz)	Reading_Level (dBuV)			Correct Factor	Measurement (dBuV)			Limit (dBuV)		Margin (dB)		P/F	Comment
		Peak	QP	AVG		dB	Peak	QP	AVG	QP	AVG	QP		
1	0.2300	37.66		26.30	10.25	47.91		36.55	62.45	52.45	-14.54	-15.90	P	
2	0.5980	27.46		17.70	10.31	37.77		28.01	56.00	46.00	-18.23	-17.99	P	
3	0.9300	33.71		24.57	10.40	44.11		34.97	56.00	46.00	-11.89	-11.03	P	
4	3.8220	32.43		20.02	10.46	42.89		30.48	56.00	46.00	-13.11	-15.52	P	
5	8.4459	22.21		12.36	10.34	32.55		22.70	60.00	50.00	-27.45	-27.30	P	
6	22.2139	28.31		16.47	10.12	38.43		26.59	60.00	50.00	-21.57	-23.41	P	

APPENDIX A: PHOTOGRAPHS OF TEST SETUP
CONDUCTED EMISSION TEST SETUP

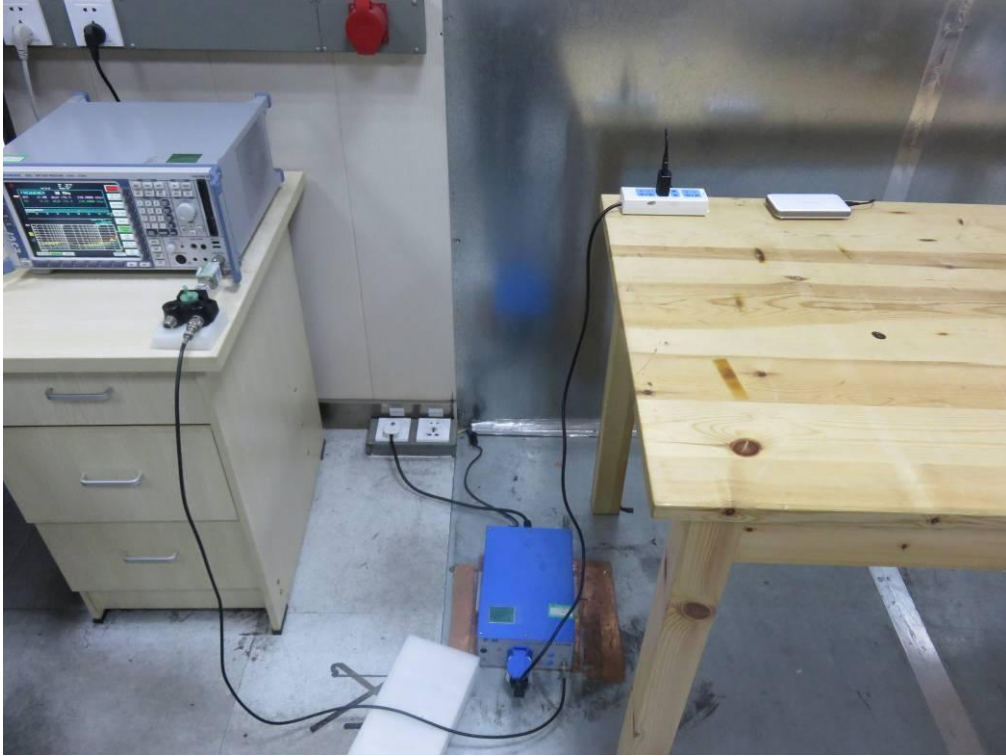

FCC RADIATED EMISSION TEST SETUP

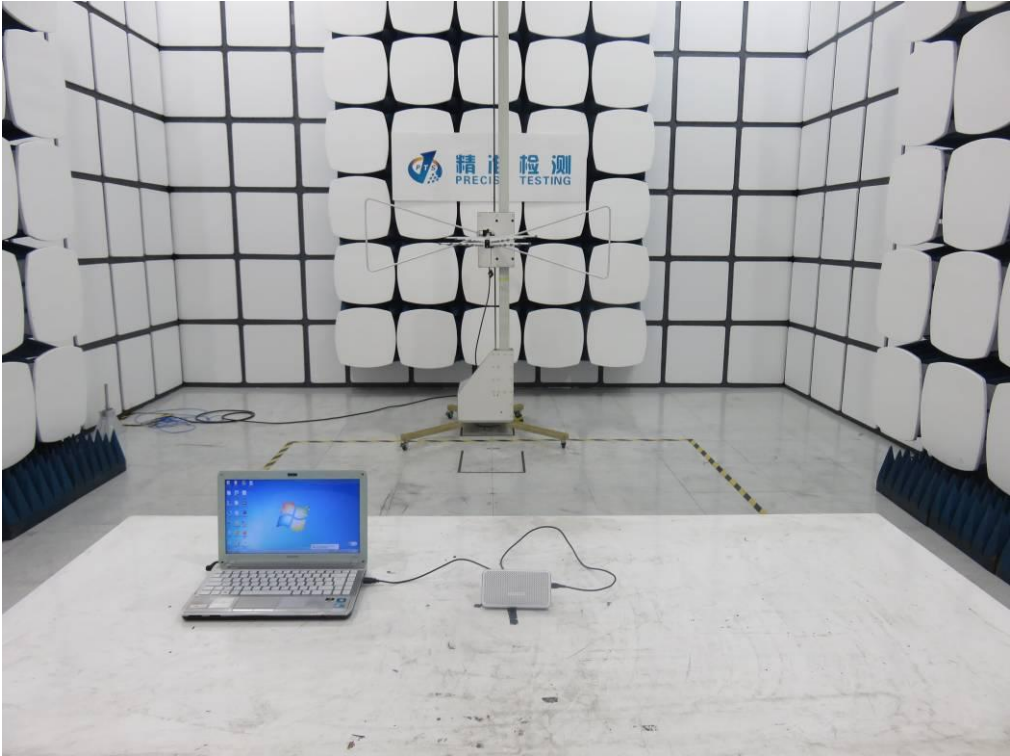
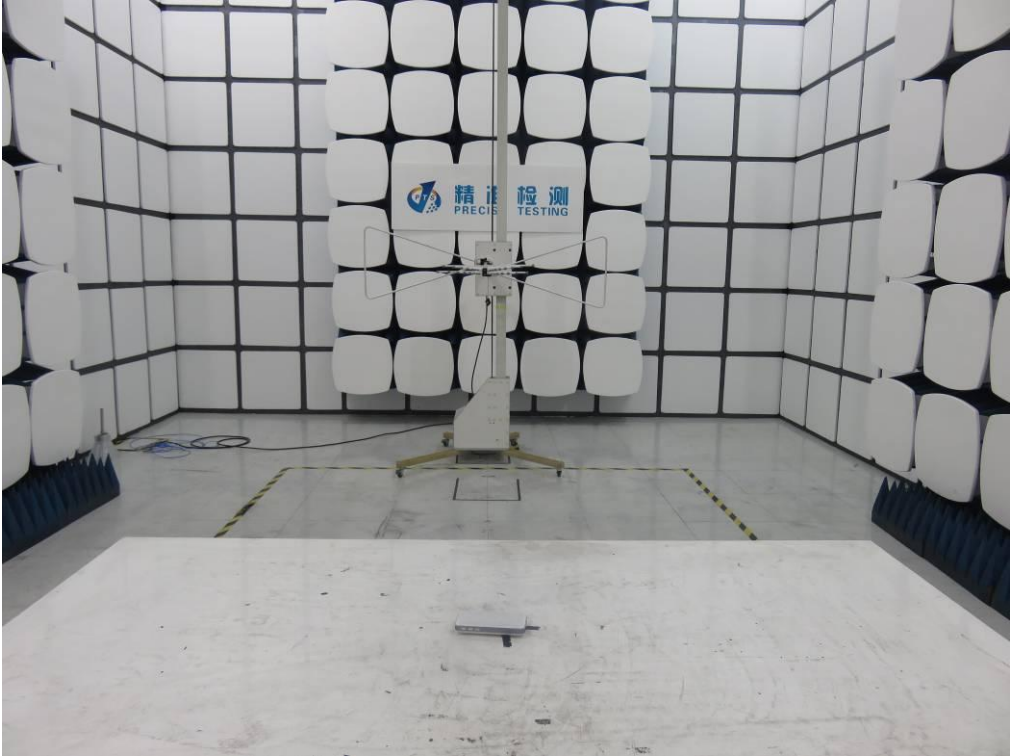

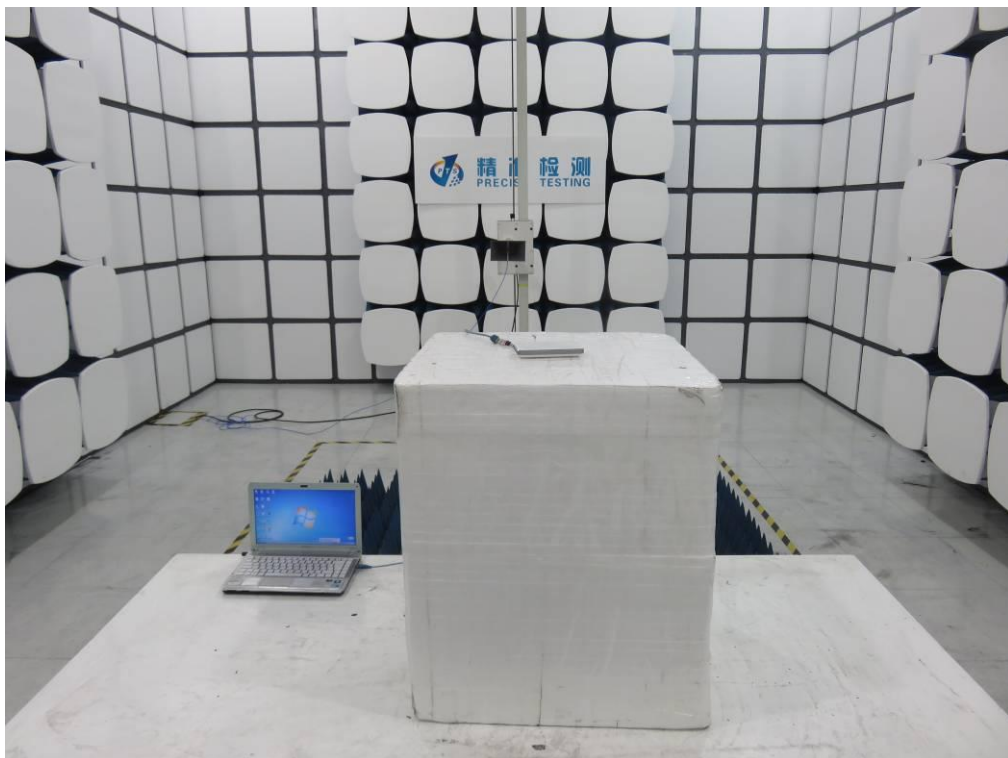
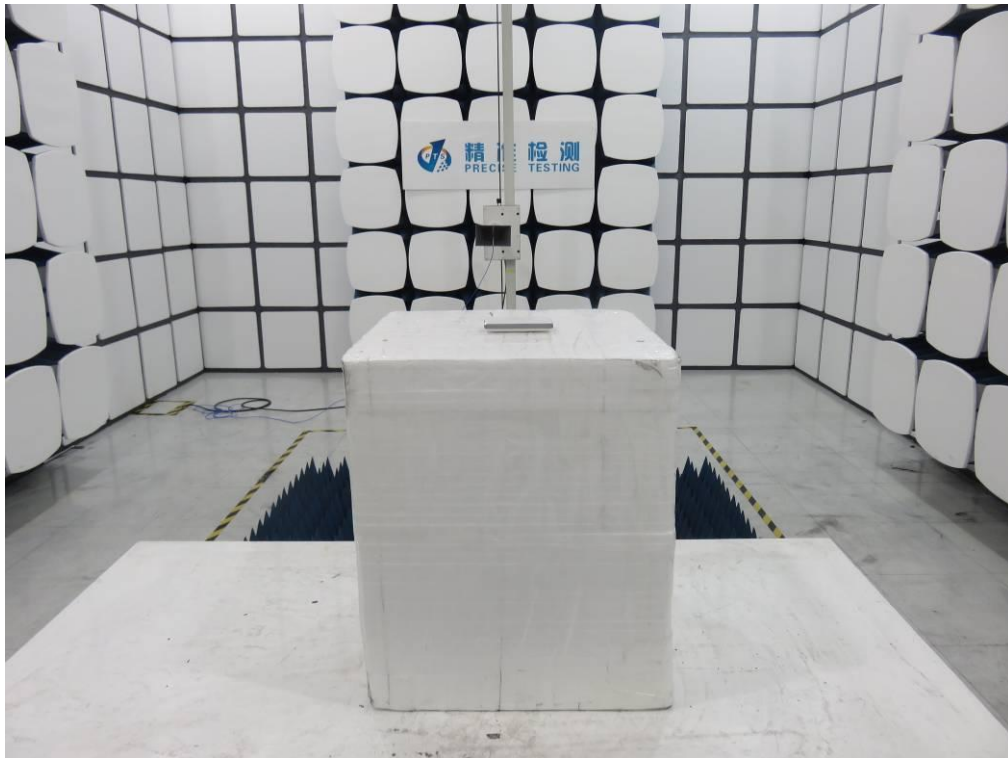

APPENDIX B: PHOTOGRAPHS OF EUT
TOP VIEW OF EUT

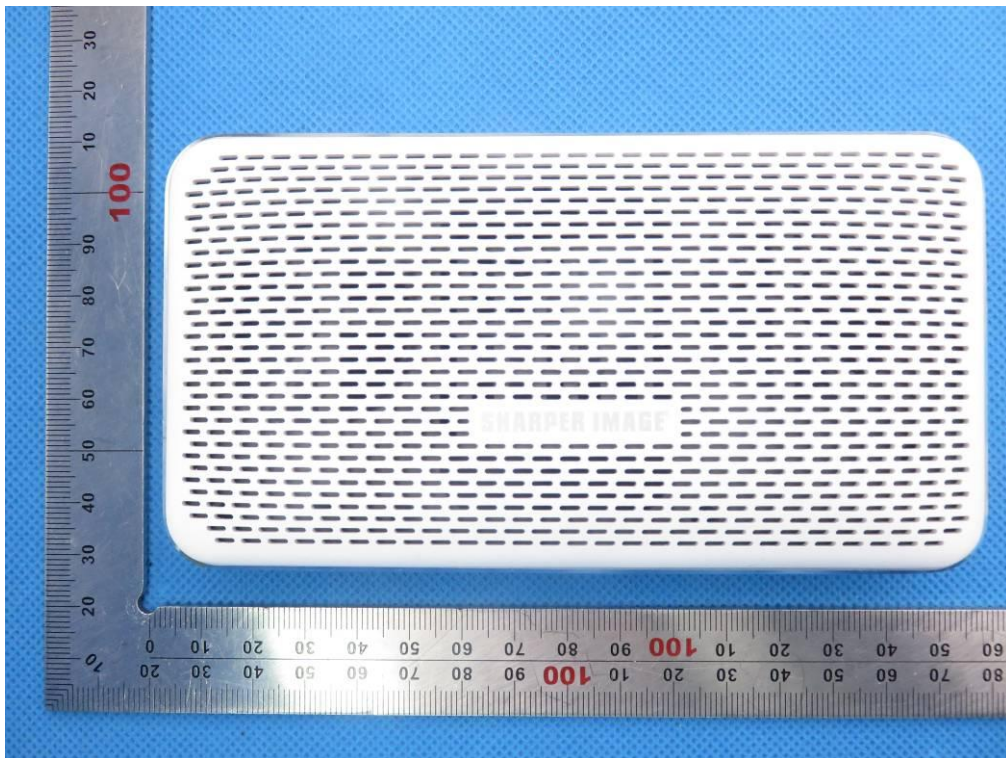

BOTTOM VIEW OF EUT

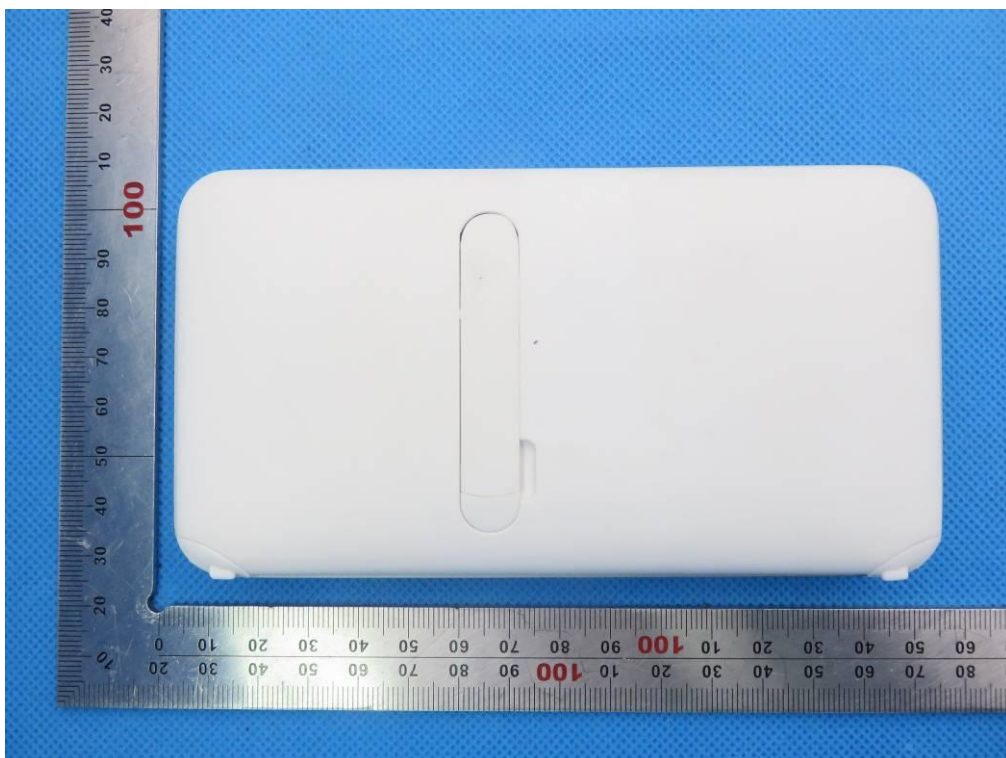

FRONT VIEW OF EUT



BACK VIEW OF EUT



LEFT VIEW OF EUT



RIGHT VIEW OF EUT

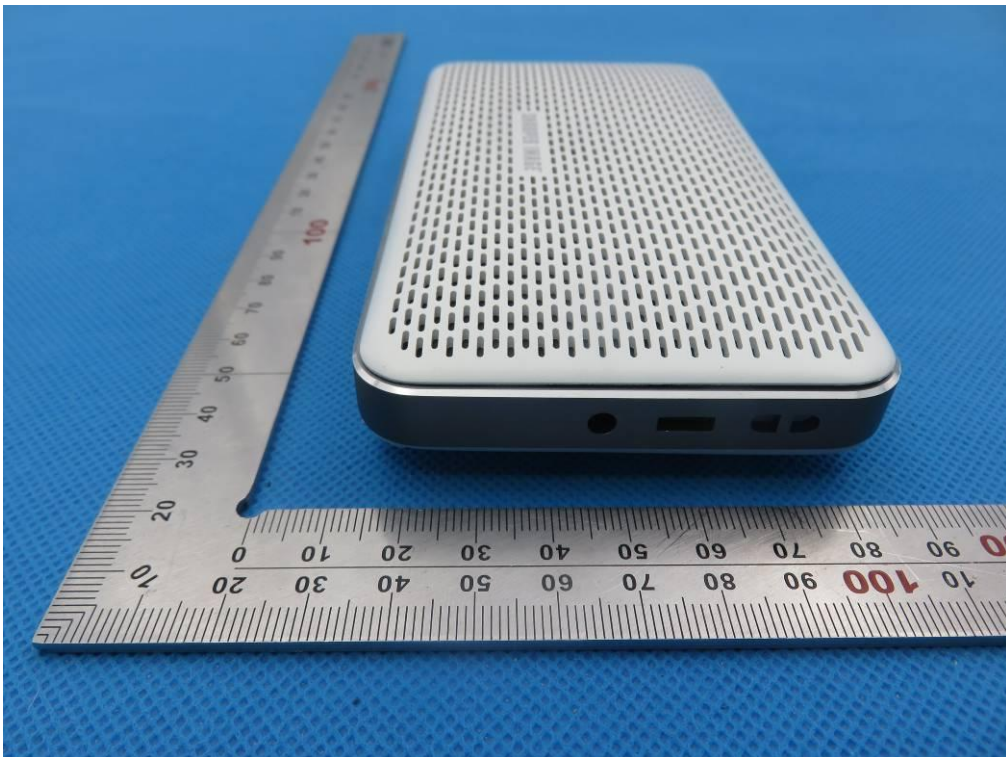

VIEW OF EUT (PORT)



OPEN VIEW OF EUT

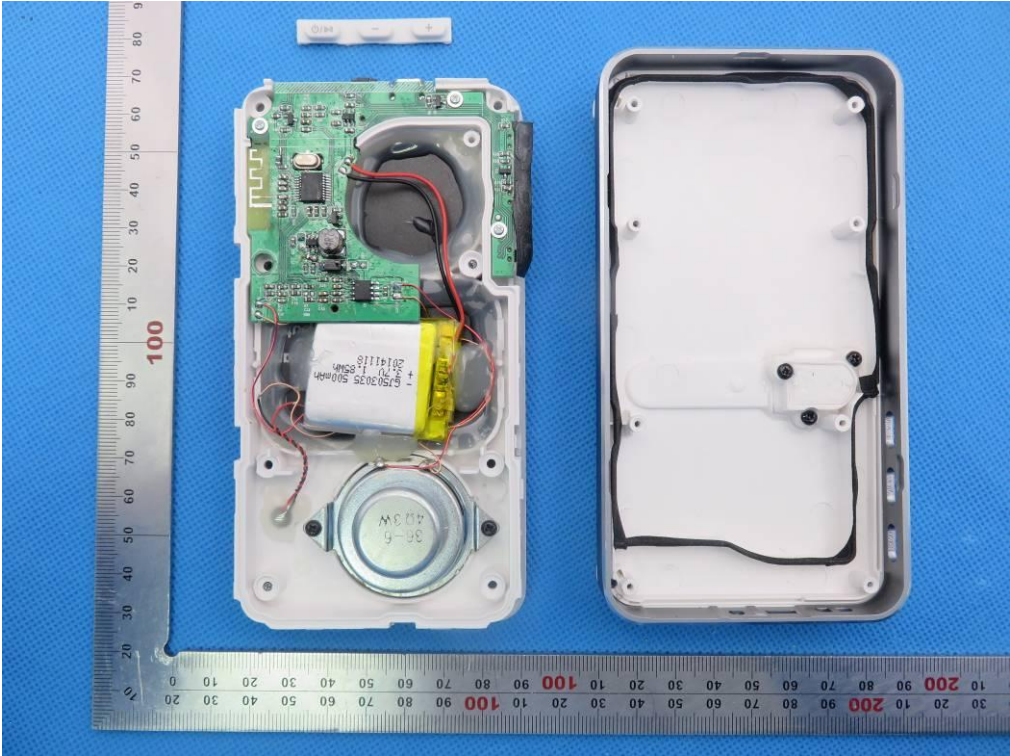

INTERNAL VIEW OF EUT-1

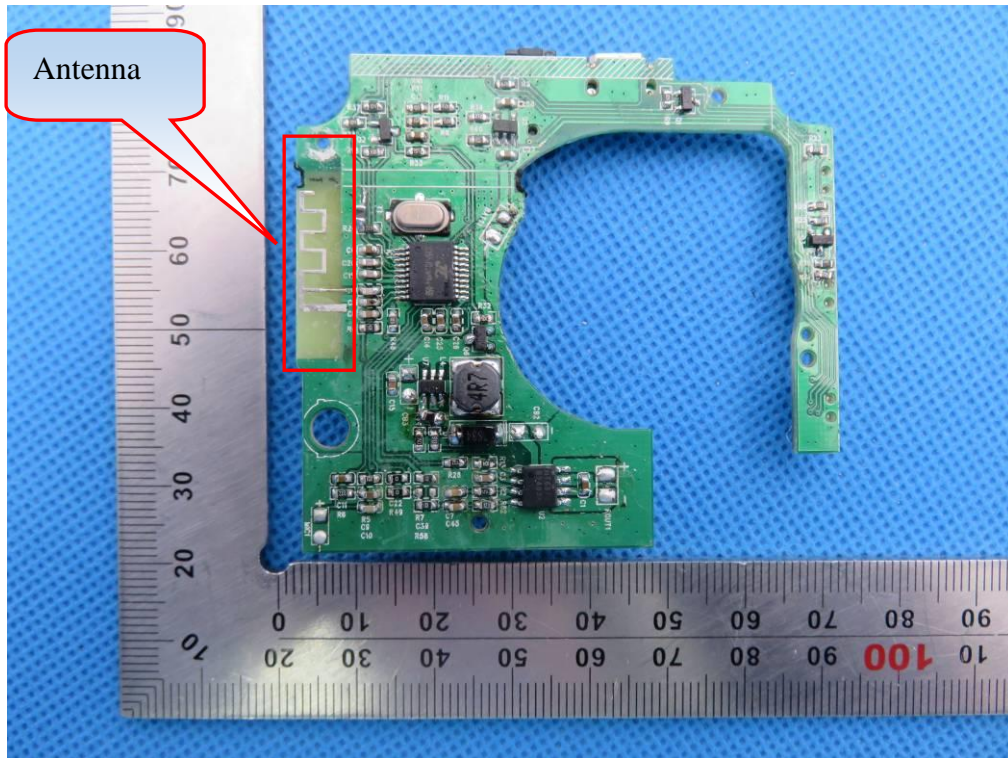

INTERNAL VIEW OF EUT-2

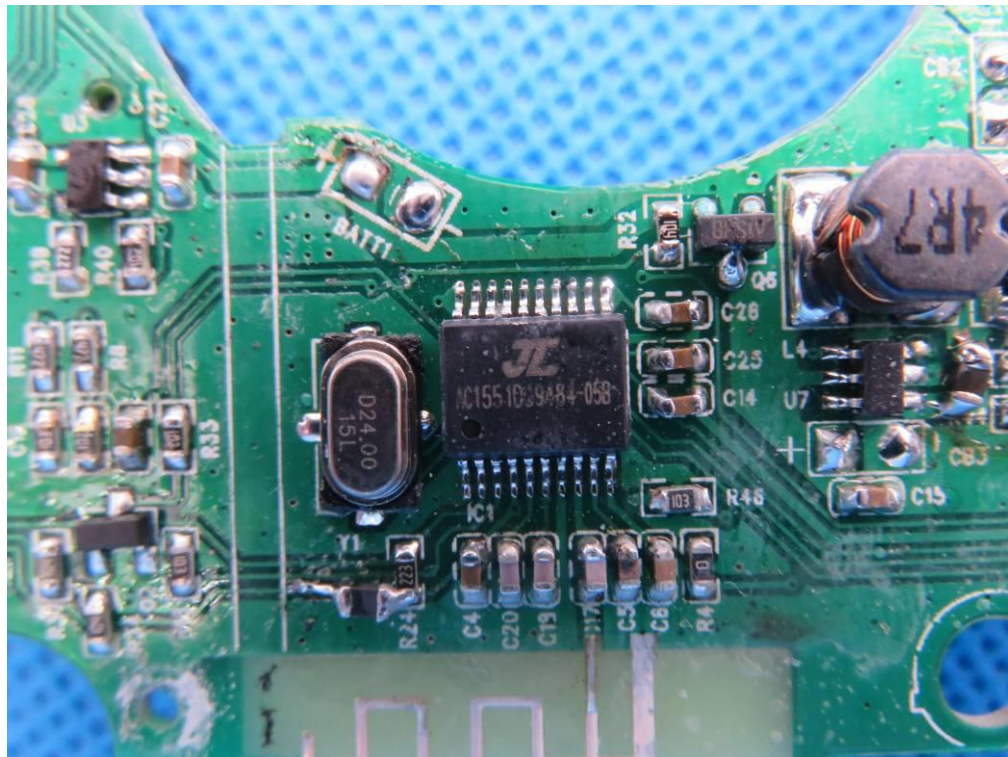

INTERNAL VIEW OF EUT-3

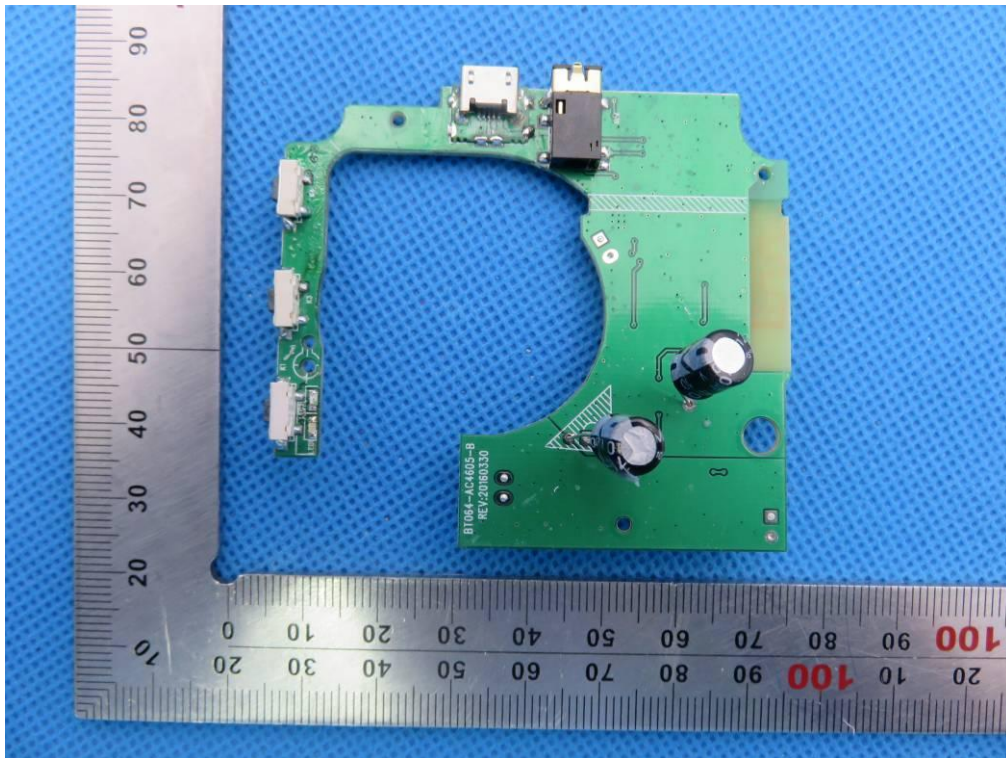

VIEW OF ADAPTER(AE)



The adapter was supplied by AGC

----END OF REPORT----