

PRELIMINARY DATA SHEET

NEC

C to KU BAND SUPER LOW NOISE AMPLIFIER N-CHANNEL HJ-FET

NE325S01

FEATURES

- **SUPER LOW NOISE FIGURE:**
0.45 dB TYP at 12 GHz
- **HIGH ASSOCIATED GAIN:**
12.5 dB TYP at 12 GHz
- **GATE LENGTH:** $\leq 0.20 \mu\text{m}$
- **GATE WIDTH:** $200 \mu\text{m}$
- **LOW COST PLASTIC PACKAGE**

DESCRIPTION

The NE325S01 is a Hetero-Junction FET that uses the junction between Si-doped AlGaAs and undoped InGaAs to create very high mobility electrons. Its excellent low noise figure and high associated gain make it suitable for commercial systems and industrial applications.

NEC's stringent quality assurance and test procedures assure the highest reliability and performance.

NOISE FIGURE & ASSOCIATED GAIN vs. FREQUENCY

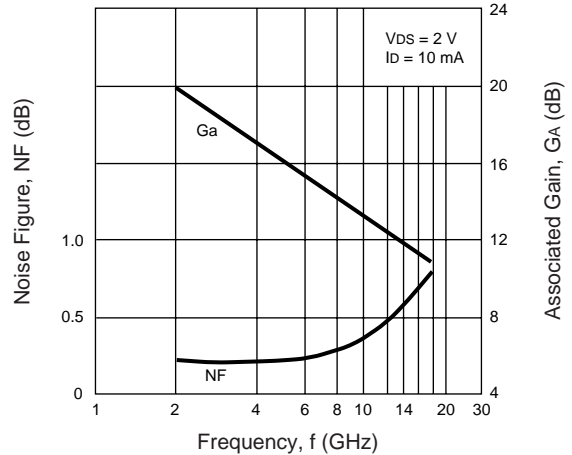

RECOMMENDED OPERATING CONDITIONS (TA = 25°C)

SYMBOLS	CHARACTERISTICS	UNITS	MIN	TYP	MAX
V _{DS}	Drain to Source Voltage	V		2	3
I _D	Drain Current	mA		10	20
P _{in}	Input Power	dBm			0

ELECTRICAL CHARACTERISTICS (TA = 25°C)

PART NUMBER PACKAGE OUTLINE			NE325S01 S01		
SYMBOLS	PARAMETERS AND CONDITIONS	UNITS	MIN	TYP	MAX
NF ¹	Noise Figure, V _{DS} = 2 V, I _D = 10 mA, f = 12 GHz	dB		0.45	0.55
GA ¹	Associated Gain, V _{DS} = 2 V, I _D = 10 mA, f = 12 GHz	dB	11.0	12.5	
I _{DSS}	Saturated Drain Current, V _{DS} = 2 V, V _{GS} = 0 V	mA	20	60	90
g _m	Transconductance, V _{DS} = 2 V, I _D = 10 mA	mS	45	60	
V _{GS(off)}	Gate to Source Cutoff Voltage, V _{DS} = 2 V, I _D = 100 μA	V	-0.2	-0.7	-2.0
I _{GSO}	Gate to Source Leak Current, V _{GS} = -3 V	μA		0.5	10

Note:

1. Typical values of noise figures and associated gain are those obtained when 50% of the devices from a large number of lots were individually measured in a circuit with the input individually tuned to obtain the minimum value. Maximum values are criteria established on the production line as a "go-no-go" screening tuned for the "generic" type but not each specimen.

ABSOLUTE MAXIMUM RATINGS¹ (T_A = 25°C)

SYMBOLS	PARAMETERS	UNITS	RATINGS
V _{DS}	Drain to Source Voltage	V	4.0
V _{GS}	Gate to Source Voltage	V	-3.0
I _D	Drain Current	mA	I _{DSS}
I _G	Gate Current	μA	100
P _T	Total Power Dissipation	mW	165
T _{CH}	Channel Temperature	°C	125
T _{stg}	Storage Temperature	°C	-65 to +125

Note:

1. Operation in excess of any one of these parameters may result in permanent damage.

NOISE FIGURE, ASSOCIATED GAIN vs. DRAIN CURRENT

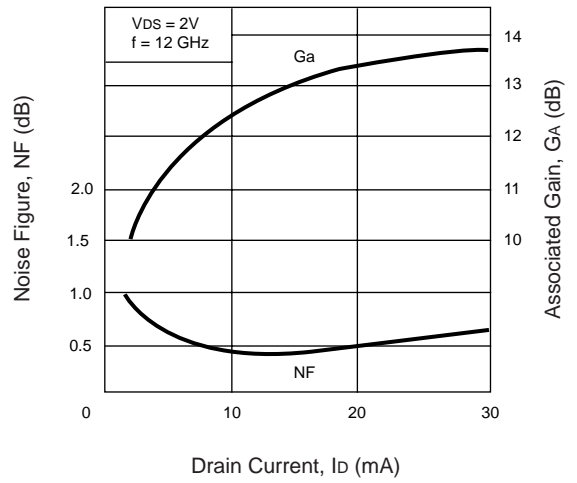

TYPICAL PERFORMANCE CURVES (T_A = 25°C)

TOTAL POWER DISSIPATION vs. AMBIENT TEMPERATURE

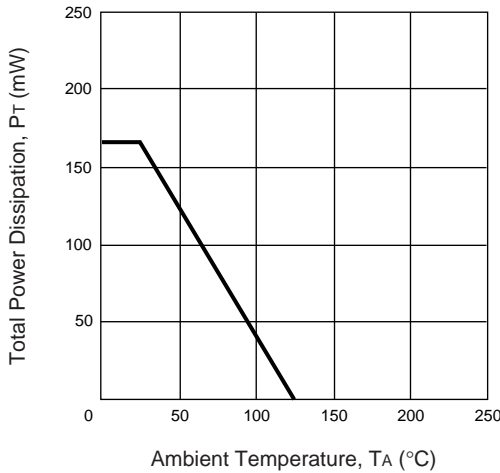

DRAIN CURRENT vs. DRAIN TO SOURCE VOLTAGE

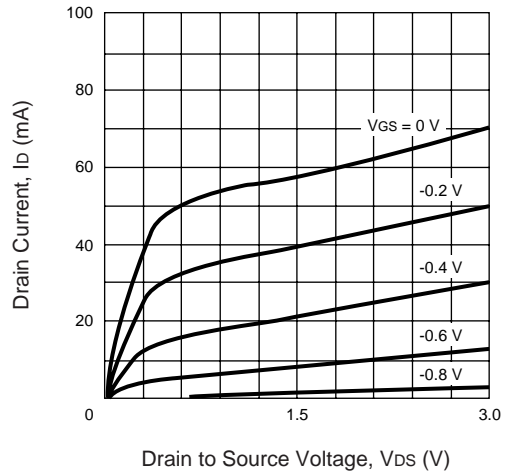

DRAIN CURRENT vs. GATE TO SOURCE VOLTAGE

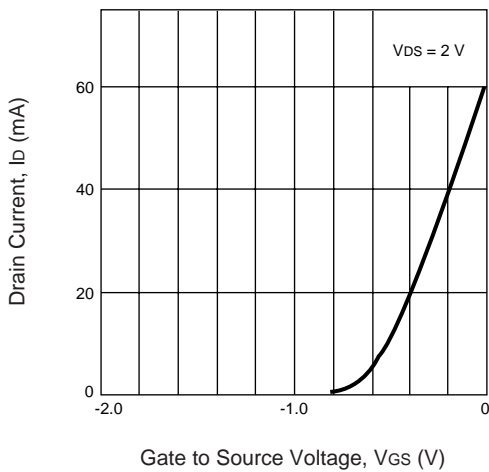

MAXIMUM AVAILABLE GAIN, FORWARD INSERTION GAIN vs. FREQUENCY

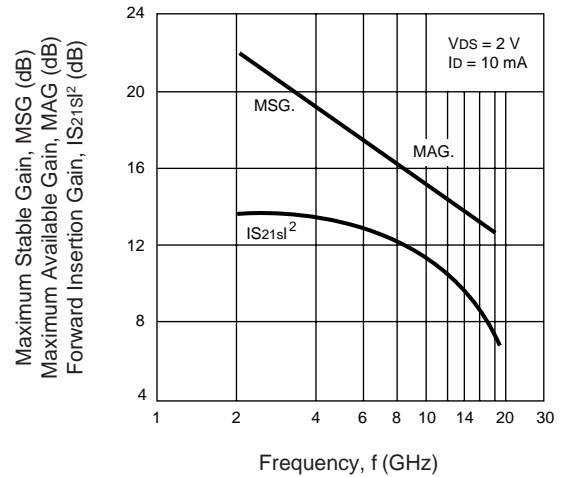

TYPICAL COMMON SOURCE SCATTERING PARAMETERS (TA = 25°C)

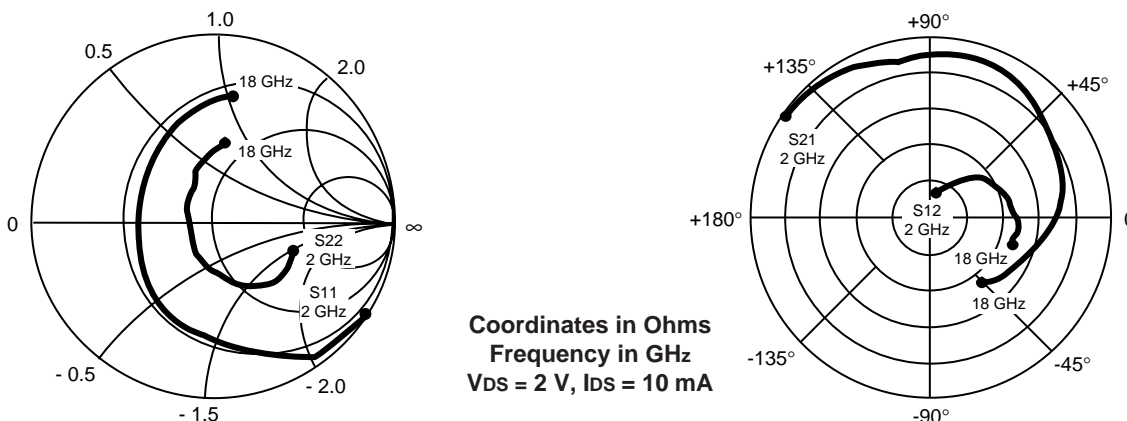

Vds = 2 V, Id = 10 mA

FREQUENCY (GHz)	S11		S21		S12		S22		K	MAG ¹ (dB)
	MAG	ANG	MAG	ANG	MAG	ANG	MAG	ANG		
2.0	0.969	-24.84	4.798	152.65	0.026	73.02	0.574	-18.45	0.237	22.661
2.5	0.957	-30.87	4.756	146.03	0.032	68.77	0.566	-22.99	0.277	21.721
3.0	0.944	-36.91	4.730	139.49	0.038	64.98	0.556	-27.48	0.310	20.951
3.5	0.926	-43.10	4.699	132.75	0.044	60.81	0.544	-32.03	0.358	20.286
4.0	0.906	-49.43	4.663	126.04	0.050	56.76	0.531	-36.56	0.403	19.697
4.5	0.884	-55.58	4.600	119.31	0.055	52.64	0.515	-41.22	0.454	19.224
5.0	0.852	-62.02	4.523	112.42	0.060	48.77	0.496	-45.75	0.524	18.773
5.5	0.819	-68.28	4.449	105.80	0.064	44.73	0.475	-50.42	0.595	18.421
6.0	0.785	-74.48	4.370	99.62	0.068	41.16	0.454	-55.09	0.659	18.080
6.5	0.753	-80.82	4.276	93.42	0.072	37.54	0.434	-59.78	0.716	17.737
7.0	0.723	-87.00	4.200	87.18	0.075	34.03	0.414	-64.50	0.771	17.482
7.5	0.696	-93.23	4.136	81.15	0.078	30.60	0.396	-69.09	0.816	17.245
8.0	0.670	-99.64	4.066	75.30	0.081	27.44	0.379	-73.80	0.854	17.007
8.5	0.643	-105.78	4.011	69.03	0.084	24.34	0.363	-78.31	0.894	16.790
9.0	0.622	-112.38	3.968	63.04	0.087	21.18	0.347	-82.72	0.919	16.591
9.5	0.597	-119.18	3.920	56.93	0.090	18.07	0.330	-87.24	0.950	16.390
10.0	0.571	-126.73	3.857	50.48	0.092	14.85	0.308	-91.89	0.995	16.225
10.5	0.538	-134.31	3.799	44.20	0.094	11.58	0.287	-96.77	1.047	14.743
11.0	0.503	-142.42	3.740	38.29	0.096	8.35	0.262	-102.63	1.100	13.983
11.5	0.475	-150.84	3.621	32.04	0.098	5.11	0.237	-109.34	1.156	13.284
12.0	0.453	-160.32	3.545	25.99	0.099	1.78	0.214	-116.89	1.200	12.834
12.5	0.435	-170.10	3.482	20.11	0.101	-1.21	0.191	-126.44	1.227	12.500
13.0	0.422	179.93	3.423	14.37	0.102	-4.53	0.173	-137.47	1.255	12.220
13.5	0.413	169.88	3.362	8.03	0.103	-7.66	0.160	-149.76	1.278	11.970
14.0	0.408	159.68	3.309	1.70	0.104	-11.00	0.151	-161.84	1.294	11.771
14.5	0.405	149.30	3.250	-4.80	0.106	-14.39	0.145	-174.45	1.302	11.572
15.0	0.406	138.94	3.182	-11.37	0.107	-17.92	0.144	171.72	1.316	11.364
15.5	0.410	128.31	3.108	-18.01	0.108	-21.80	0.148	157.82	1.330	11.155
16.0	0.418	117.54	3.031	-24.47	0.109	-25.41	0.154	142.64	1.343	10.940
16.5	0.434	106.98	2.943	-30.70	0.110	-29.36	0.168	127.26	1.350	10.739
17.0	0.455	96.84	2.869	-37.11	0.111	-33.17	0.188	114.01	1.344	10.619
17.5	0.484	87.21	2.799	-43.55	0.111	-37.06	0.214	102.68	1.330	10.577
18.0	0.521	77.71	2.720	-50.10	0.111	-41.23	0.246	92.62	1.303	10.591

Note:

1. Gain Calculation:

$$MAG = \frac{|S_{21}|}{|S_{12}|} (K \pm \sqrt{K^2 - 1})$$

When $K \leq 1$, MAG is undefined and MSG values are used. $MSG = \frac{|S_{21}|}{|S_{12}|}$, $K = \frac{1 + |\Delta|^2 - |S_{11}|^2 - |S_{22}|^2}{2 |S_{12} S_{21}|}$, $\Delta = S_{11} S_{22} - S_{21} S_{12}$

MAG = Maximum Available Gain

MSG = Maximum Stable Gain

NONLINEAR MODEL

SCHEMATIC

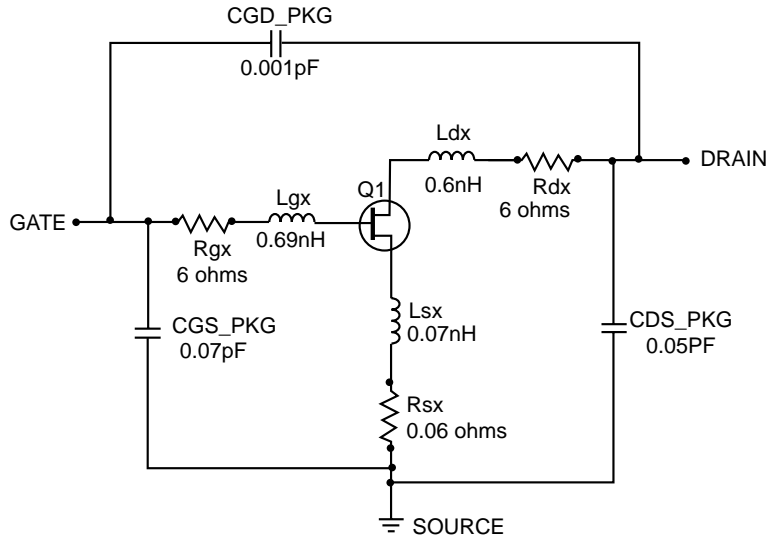

FET NONLINEAR MODEL PARAMETERS ⁽¹⁾

Parameters	Q1	Parameters	Q1
VTO	-0.8	RG	3
VTOSC	0	RD	2
ALPHA	8	RS	2
BETA	0.103	RGMET	0
GAMMA	0.092	KF	0
GAMMADC	0.08	AF	1
Q	2	TNOM	27
DELTA	1	XTI	3
VBI	0.715	EG	1.43
IS	3e-13	VTOTC	0
N	1.22	BETATCE	0
RIS	0	FFE	1
RID	0		
TAU	4e-12		
CDS	0.13e-12		
RDB	5000		
CBS	1e-9		
CGSO	0.3e-12		
CGDO	0.02e-12		
DELTA1	0.3		
DELTA2	0.1		
FC	0.5		
VBR	Infinity		

UNITS

Parameter	Units
time	seconds
capacitance	farads
inductance	henries
resistance	ohms
voltage	volts
current	amps

MODEL RANGE

Frequency: 0.1 to 18 GHz
 Bias: $V_{ds} = 1\text{ V to }3\text{ V}$, $I_D = 5\text{ mA to }30\text{ mA}$
 $I_{DSS} = 59.9\text{ ma @ }V_{gs} = 0, V_{ds} = 2\text{ V}$
 Date: 2/98

(1) Series IV Libra TOM Model

OUTLINE DIMENSIONS (Units in mm)

PACKAGE OUTLINE S01

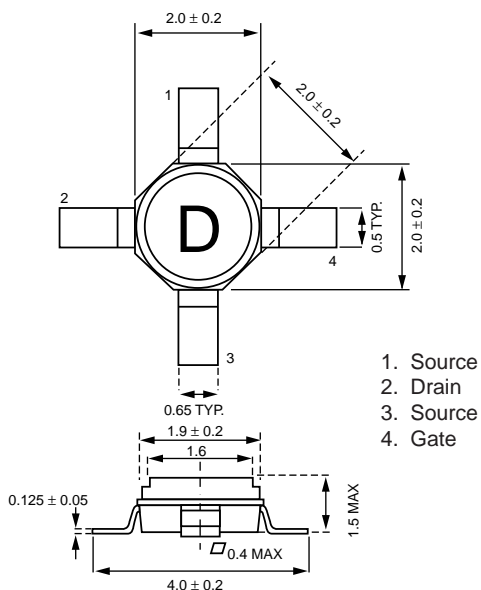

- 1. Source
- 2. Drain
- 3. Source
- 4. Gate

TYPICAL NOISE PARAMETERS (T_A = 25°C)

V_{DS} = 2 V, I_D = 10 mA

FREQ. (GHz)	NF _{MIN} (dB)	G _A (dB)	Γ _{OPT}		R _n /50
			MAG	ANG	
2	0.29	20.0	0.93	14	0.38
4	0.30	18.3	0.80	29	0.33
6	0.32	16.5	0.65	48	0.25
8	0.35	15.0	0.49	72	0.18
10	0.40	13.6	0.36	102	0.11
12	0.45	12.5	0.27	139	0.08
14	0.53	12.0	0.24	-176	0.07
16	0.67	11.8	0.30	-122	0.10
18	0.83	11.5	0.47	-58	0.22

TYPICAL CONSTANT NOISE FIGURE CIRCLE (V_{DS} = 2 V, I_D = 10 mA, f = 12 GHz)

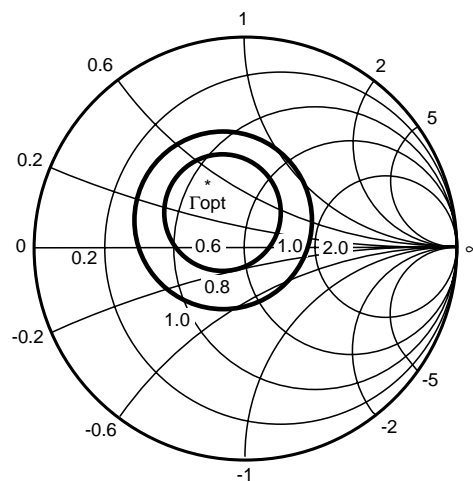

ORDERING INFORMATION

PART NUMBER	SUPPLY FORM	PACKAGE OUTLINE
NE325S01	Bulk	S01
NE325S01-T1	Tape & Reel 1000 pcs./reel	S01
NE325S01-T1B	Tape & Reel 4000 pcs./reel	S01

EXCLUSIVE NORTH AMERICAN AGENT FOR **NEC** RF, MICROWAVE & OPTOELECTRONIC SEMICONDUCTORS

CEL CALIFORNIA EASTERN LABORATORIES • Headquarters • 4590 Patrick Henry Drive • Santa Clara, CA 95054-1817 • (408) 988-3500 • Telex 34-6393 • FAX (408) 988-0279

24-Hour Fax-On-Demand: 800-390-3232 (U.S. and Canada only) • Internet: <http://WWW.CEL.COM>

DATA SUBJECT TO CHANGE WITHOUT NOTICE

PRINTED IN USA ON RECYCLED PAPER -2/99