

FCC RADIO TEST REPORT

FCC ID: OXGZW1101

Product Name:	Door window sensor
Trademark:	Show Home
Model Number:	ZW1101
Prepared For :	Willis Electric CO.,Ltd.
Address :	No.504-1,Chung-Hua Road, Sec.4, Hsin Chu,300 Taiwan
Prepared By :	DongGuan Precise Testing Service Co.,Ltd.
Address :	Building D, Baoding Technology Park, Guangming Road 2, Guangming Community, Dongcheng District, Dongguan, Guangdong, China
Test Date:	May 10 – May 20, 2015
Date of Report :	May 20, 2015
Report No.:	PTS 15030580019F

**VERIFICATION OF COMPLIANCE**

Applicant:	Willis Electric CO.,Ltd.
Address	No.504-1,Chung-Hua Road, Sec.4, Hsin Chu,300 Taiwan
Manufacturer Name:	Kupoint(DongGuan)Electric Co.,Ltd
Address:	Huai De Village, HumenTown, Dong Guan, Guang Dong, China
Product Description:	Door window sensor
Brand Name:	Show Home
Model Name:	ZW1101
Model difference:	N/A
Test procedure	ANSI C63.10-2013
Standards	FCC PART15.249

Prepared by :

Jones Song /Assistant

Reviewer :

David liu /Supervisor

Approved & Authorized Signer :

Jacky Ou/Manager



Table of Contents	Page
1 . SUMMARY OF TEST RESULTS	4
1.1 TEST FACILITY	5
1.2 MEASUREMENT UNCERTAINTY	5
2 . GENERAL INFORMATION	6
2.1 GENERAL DESCRIPTION OF EUT	6
2.2 DESCRIPTION OF TEST MODES	7
2.3 BLOCK DIGRAM SHOWING THE CONFIGURATION OF SYSTEM TESTED	8
2.4 DESCRIPTION OF SUPPORT UNITS(CONDUCTED MODE)	9
2.5 EQUIPMENTS LIST FOR ALL TEST ITEMS	10
FOR RADIATED EMISSION TEST (BELOW 1GHZ)	10
FOR RADIATED EMISSION TEST (1GHZ ABOVE)	10
3 . TEST RESULT	12
3.1 ANTENNA REQUIREMENT	12
3.1.1 STANDARD REQUIREMENT	12
3.1.2 EUT ANTENNA	12
3.2 CONDUCTED EMISSION MEASUREMENT	13
3.2.1 POWER LINE CONDUCTED EMISSION LIMITS	13
3.2.2 TEST PROCEDURE	14
3.2.3 DEVIATION FROM TEST STANDARD	14
3.2.4 TEST SETUP	14
3.2.5 TEST RESULT	15
3.3 RADIATED EMISSION MEASUREMENT	16
3.3.1 RADIATED EMISSION LIMITS	16
3.3.2 TEST PROCEDURE	17
3.3.3 DEVIATION FROM TEST STANDARD	17
3.3.4 TEST SETUP	18
3.3.5 TEST RESULTS (BLOW 30MHZ)	20
3.3.6 TEST RESULTS (BETWEEN 30 – 1000 MHZ)	21
3.3.7 TEST RESULTS (ABOVE 1000 MHZ)	24
4 . 20DB AND 99 % BANDWIDTH TEST	26
4.1 TEST PROCEDURE	26
4.2 DEVIATION FROM STANDARD	26
4.3 TEST SETUP	26
4.4 TEST RESULTS	27
APPENDIX-PHOTOGRAPHS OF EUT CONSTRUCTIONAL DETAILS	



1. SUMMARY OF TEST RESULTS

Test procedures according to the technical standards:

FCC Part15, Subpart C (15.249)			
Standard Section	Test Item	Judgment	Remark
15.207	Conducted Emission	N/A	
15.203	Antenna Requirement	Pass	
15.249(a)&(d)&15.209	Radiated Spurious Emission	Pass	
15.215	20 DB Bandwidth	Pass	
15.249(d)&15.209	Band Edge Emission	Pass	
15.249(a)	Fundamental Measurement	Pass	



1.1 TEST FACILITY

FCC Registration No.: 371540, IC Registration No.: 12191A-1

Dongguan Precise Testing Service Co., Ltd.

Add.: Building D, Baoding Technology Park, Guangming Road2, Dongcheng District,
Dongguan, Guangdong, China

1.2 MEASUREMENT UNCERTAINTY

The reported uncertainty of measurement $y \pm U$, where expanded uncertainty U is based on a standard uncertainty multiplied by a coverage factor of $k=2$, providing a level of confidence of approximately **95 %**.

No.	Item	Uncertainty
1	Conducted Emission Test	$\pm 1.38\text{dB}$
2	RF power,conducted	$\pm 0.16\text{dB}$
3	Spurious emissions,conducted	$\pm 0.21\text{dB}$
4	All emissions,radiated(<1G)	$\pm 4.68\text{dB}$
5	All emissions,radiated(>1G)	$\pm 4.89\text{dB}$
6	Temperature	$\pm 0.5^\circ\text{C}$
7	Humidity	$\pm 2\%$



2. GENERAL INFORMATION

2.1 GENERAL DESCRIPTION OF EUT

Equipment	Door window sensor	
Trade Name	Show Home	
Model Name	ZW1101	
Serial Model	N/A	
Model Difference	N/A	
Product Description	The EUT is a Door window sensor	
	Operation Frequency:	908.42MHz
	Modulation Type:	FSK
	Channel number	1 channel
	Antenna Designation:	Wire antenna
	Antenna Gain(Peak)	-2.6dBi
	Max. PK field strength	86.92 dBuV/m
Based on the application, features, or specification exhibited in User's Manual, the EUT is considered as an ITE/Computing Device. More details of EUT technical specification, please refer to the User's Manual.		
Power Supply	DC 3V	
HVIN	ZW1101	
FVIN	F_smart receptacle V1	

Note:

1. For a more detailed features description, please refer to the manufacturer's specifications or the User's Manual.



2.2 DESCRIPTION OF TEST MODES

To investigate the maximum EMI emission characteristics generates from EUT, the test system was pre-scanning tested base on the consideration of following EUT operation mode or test configuration mode which possible have effect on EMI emission level. Each of these EUT operation mode(s) or test configuration mode(s) mentioned above was evaluated respectively.

Pretest Mode	Description
Mode 1	TX

For Conducted Emission	
Final Test Mode	Description
Mode 1	TX

For Radiated Emission	
Final Test Mode	Description
Mode 1	TX

Note: For the TX mode, the EUT is configured as the continuously transmitting mode.



2.3 BLOCK DIGRAM SHOWING THE CONFIGURATION OF SYSTEM TESTED

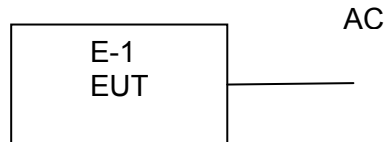



2.4 DESCRIPTION OF SUPPORT UNITS(CONDUCTED MODE)

The EUT has been tested as an independent unit together with other necessary accessories or support units. The following support units or accessories were used to form a representative test configuration during the tests.

Item	Equipment	Mfr/Brand	Model/Type No.	Series No.	Note
E-1	Door window sensor	Show Home	ZW1101	N/A	EUT

Item	Shielded Type	Ferrite Core	Length	Note

Note:

- (1) The support equipment was authorized by Declaration of Confirmation.
- (2) For detachable type I/O cable should be specified the length in cm in 『Length』 column.



2.5 EQUIPMENTS LIST FOR ALL TEST ITEMS

FOR RADIATED EMISSION TEST (BELOW 1GHZ)

Name of Equipment	Manufacturer	Model	Serial No.	Last Cal.	Next Cal.
EMI Test Receiver	Rohde & Schwarz	ESCI	101417	July 4, 2014	July 3, 2015
Trilog Broadband Antenna (25M-1GHz)	SCHWARZBECK	VULB9160	9160-3355	July 4, 2014	July 3, 2015
Signal Amplifier	SCHWARZBECK	BBV 9475	9745-0013	July 4, 2014	July 3, 2015
RF Cable	SCHWARZBECK	AK9515E	96221	July 4, 2014	July 3, 2015
3m Anechoic Chamber	CHENGYU	966	PTS-001	June 6, 2014	June 5, 2015
MULTI-DEVICE Positioning Controller	Max-Full	MF-7802	MF780208339	N/A	N/A
Active loop antenna (9K-30MHz)	Schwarzbeck	FMZB1519	1519-038	June 6, 2014	June 5, 2015
Spectrum analyzer	Agilent	E4407B	MY46185649	June 6, 2014	June 5, 2015

FOR RADIATED EMISSION TEST (1GHZ ABOVE)

Name of Equipment	Manufacturer	Model	Serial No.	Last Cal.	Next Cal.
EMI Test Receiver	Rohde & Schwarz	ESCI	101417	July 4, 2014	July 3, 2015
Horn Antenna (1G-18GHz)	SCHWARZBECK	BBHA9120D	9120D-1246	July 11, 2014	July 10, 2015
Spectrum Analyzer	Agilent	E4411B	MY4511453	July 4, 2014	July 3, 2015
Signal Amplifier	SCHWARZBECK	BBV 9718	9718-269	July 7, 2014	July 6, 2015
RF Cable	SCHWARZBECK	AK9515H	96220	July 8, 2014	July 7, 2015
3m Anechoic Chamber	CHENGYU	966	PTS-001	June 6, 2014	June 5, 2015
MULTI-DEVICE Positioning Controller	Max-Full	MF-7802	MF780208339	N/A	N/A
Horn Ant (18G-40GHz)	Schwarzbeck	BBHA 9170	9170-181	June 6, 2014	June 5, 2015



- Note:** 1. The calibration interval of the above test instruments is 12 months and the calibrations are traceable to CEPREI/CHINA and NIM/CHINA
2. N/A = No Calibration Request.

FOR CONDUCTED EMISSION TEST:

Name of Equipment	Manufacturer	Model	Serial No.	Last Cal.	Next Cal.
EMI Test Receiver	Rohde & Schwarz	ESCI	101417	July 4, 2014	July 3, 2015
Artificial Mains Network	Narda	L2-16B	000WX31025	July 8, 2014	July 7, 2015
Artificial Mains Network (AUX)	Narda	L2-16B	000WX31026	July 8, 2014	July 7, 2015
RF Cable	SCHWARZBECK	AK9515E	96222	July 4, 2014	July 3, 2015
Shielded Room	CHENGYU	843	PTS-002	June 6, 2014	June 5, 2015

- Note:** 1. The calibration interval of the above test instruments is 12 months and the calibrations are traceable to CEPREI/CHINA and NIM/CHINA



3. TEST RESULT

3.1 ANTENNA REQUIREMENT

3.1.1 STANDARD REQUIREMENT

15.203 requirement: For intentional device, according to 15.203: an intentional radiator shall be designed to ensure that no antenna other than that furnished by the responsible party shall be used with the device.

3.1.2 EUT ANTENNA

The EUT antenna is Wire Antenna. It's permanent attached antenna. It comply with the standard requirement.



3.2 CONDUCTED EMISSION MEASUREMENT

3.2.1 POWER LINE CONDUCTED EMISSION Limits (Frequency Range 150KHz-30MHz)

FREQUENCY (MHz)	Class A (dBuV)		Class B (dBuV)		Standard
	Quasi-peak	Average	Quasi-peak	Average	
0.15 -0.5			66 - 56 *	56 - 46 *	CISPR
0.50 -5.0			56.00	46.00	CISPR
5.0 -30.0			60.00	50.00	CISPR

0.15 -0.5			66 - 56 *	56 - 46 *	LP002.
0.50 -5.0			56.00	46.00	LP002.
5.0 -30.0			60.00	50.00	LP002.

Note:

- (1) The tighter limit applies at the band edges.
- (2) The limit of " * " marked band means the limitation decreases linearly with the logarithm of the frequency in the range.

The following table is the setting of the receiver

Receiver Parameters	Setting
Attenuation	10 dB
Start Frequency	0.15 MHz
Stop Frequency	30 MHz
IF Bandwidth	9 kHz

3.2.2 TEST PROCEDURE

- a. The EUT was placed 0.4 meters from the horizontal ground plane with EUT being connected to the power mains through a line impedance stabilization network (LISN). All other support equipments powered from additional LISN(s). The LISN provide 50 Ohm/ 50uH of coupling impedance for the measuring instrument.
- b. Interconnecting cables that hang closer than 40 cm to the ground plane shall be folded back and forth in the center forming a bundle 30 to 40 cm long.
- c. I/O cables that are not connected to a peripheral shall be bundled in the center. The end of the cable may be terminated, if required, using the correct terminating impedance. The overall length shall not exceed 1 m.
- d. LISN at least 80 cm from nearest part of EUT chassis.
- e. For the actual test configuration, please refer to the related Item –EUT Test Photos.

3.2.3 DEVIATION FROM TEST STANDARD

No deviation

3.2.4 TEST SETUP

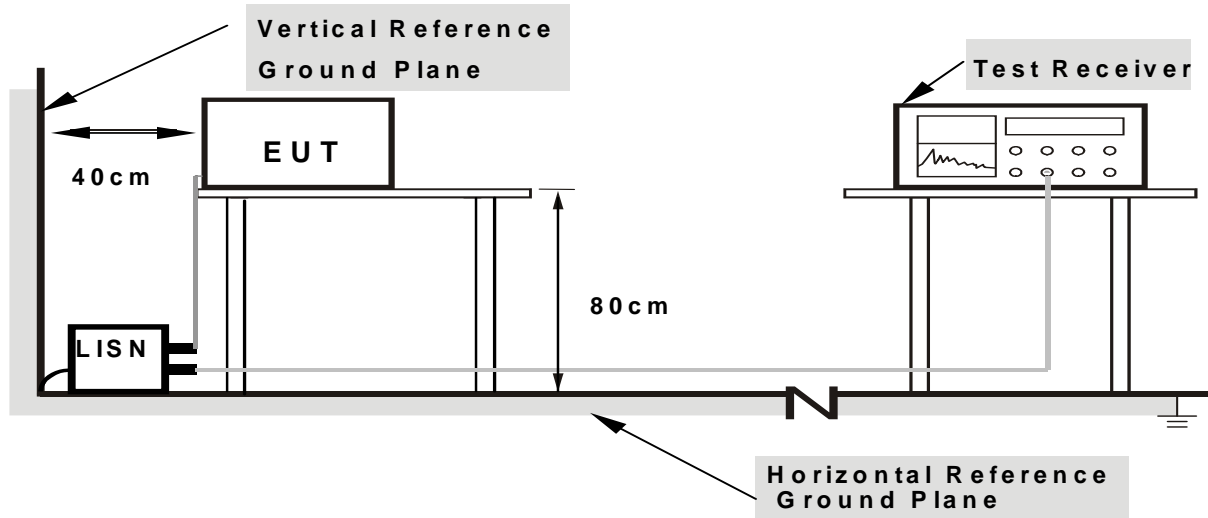

Note: 1. Support units were connected to second LISN.

2. Both of LISNs (AMN) are 80 cm from EUT and at least 80 from other units and other metal planes



3.2.5 TEST RESULT

EUT :	Door window sensor	Model Name. :	ZW1101
Temperature :	26 °C	Relative Humidity :	54%
Pressure :	1010hPa	Phase :	L
Test Voltage :	DC 3V	Test Mode :	Mode 1

Owing to the EUT use battery supply voltage, this test item is not performed.



3.3 RADIATED EMISSION MEASUREMENT

3.3.1 Radiated Emission Limits (FCC 15.209)

Frequencies (MHz)	Field Strength (micorvolts/meter)	Measurement Distance (meters)
0.009~0.490	2400/F(KHz)	300
0.490~1.705	24000/F(KHz)	30
1.705~30.0	30	30
30~88	100	3
88~216	150	3
216~960	200	3
Above 960	500	3

Note:

- (1) The tighter limit applies at the band edges.
- (2) Emission level (dBuV/m)=20log Emission level (uV/m).

LIMITS OF RADIATED EMISSION MEASUREMENT (FCC 15.249)

Frequency of Emission (MHz)	Field Strength of fundamental ((millivolts /meter)	Field Strength of Harmonics (microvolts/meter)
902-928 MHz	50	500

Notes:

- (1) Emissions radiated outside of the specified frequency bands, except for harmonics, shall be attenuated by at least 50 dB below the level of the fundamental or to the general radiated emission limits in Section 15.209, whichever is the lesser attenuation.

Spectrum Parameter	Setting
Attenuation	Auto
Start Frequency	1000 MHz
Stop Frequency	10th carrier harmonic
RB / VB (emission in restricted band)	1MHz / 1MHz for Peak

Receiver Parameter	Setting
Attenuation	Auto
Start ~ Stop Frequency	9kHz~150kHz / RB 200Hz for QP
Start ~ Stop Frequency	150kHz~30MHz / RB 9kHz for QP
Start ~ Stop Frequency	30MHz~1000MHz / RB 120kHz for QP



3.3.2 TEST PROCEDURE

- a. The measuring distance of at 3 m shall be used for measurements at frequency up to 1GHz. For frequencies above 1GHz, any suitable measuring distance may be used.
- b. The EUT was placed on the top of a rotating table 0.8 meters above the ground at a 3m meter open area test site for below 1GHz. The table was rotated 360 degrees to determine the position of the highest radiation. The EUT was place on the top of a roatating table 1.5 meters for above 1GHz.
- c. The height of the equipment or of the substitution antenna shall be 0.8 m; the height of the test antenna shall vary between 1 m to 4 m.
- d. The initial step in collecting conducted emission data is a spectrum analyzer peak detector mode pre-scanning the measurement frequency range. Significant peaks are then marked and then Quasi Peak detector mode re-measured.
- e. If the Peak Mode measured value compliance with and lower than Quasi Peak Mode Limit, the EUT shall be deemed to meet QP Limits and then no additional QP Mode measurement performed.
- f. For the actual test configuration, please refer to the related Item –EUT Test Photos.

Note:

Both horizontal and vertical antenna polarities were tested and performed pretest to three orthogonal axis. The worst case emissions were reported

3.3.3 DEVIATION FROM TEST STANDARD

No deviation

3.3.4 TEST SETUP

(A) Radiated Emission Test-Up Frequency Below 30MHz

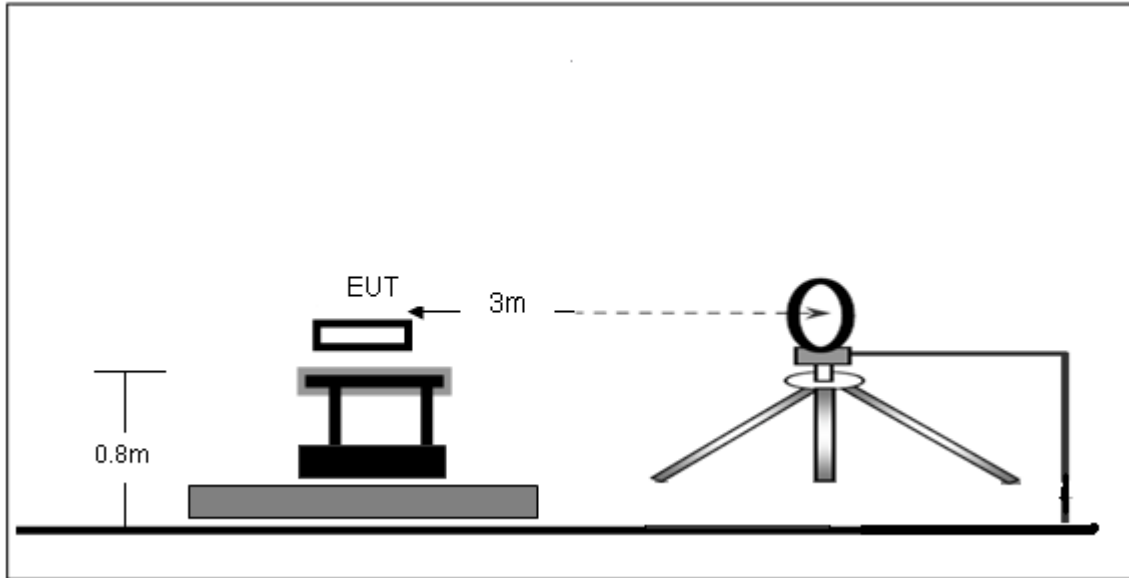

(B) Radiated Emission Test-Up Frequency 30MHz~1GHz

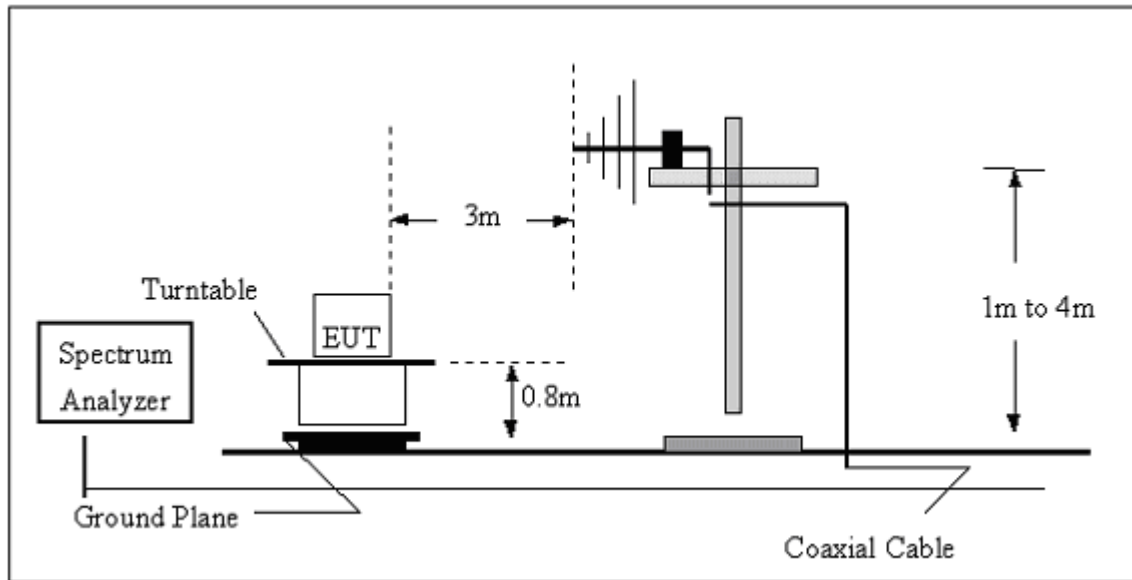

(C) Radiated Emission Test-Up Frequency Above 1GHz

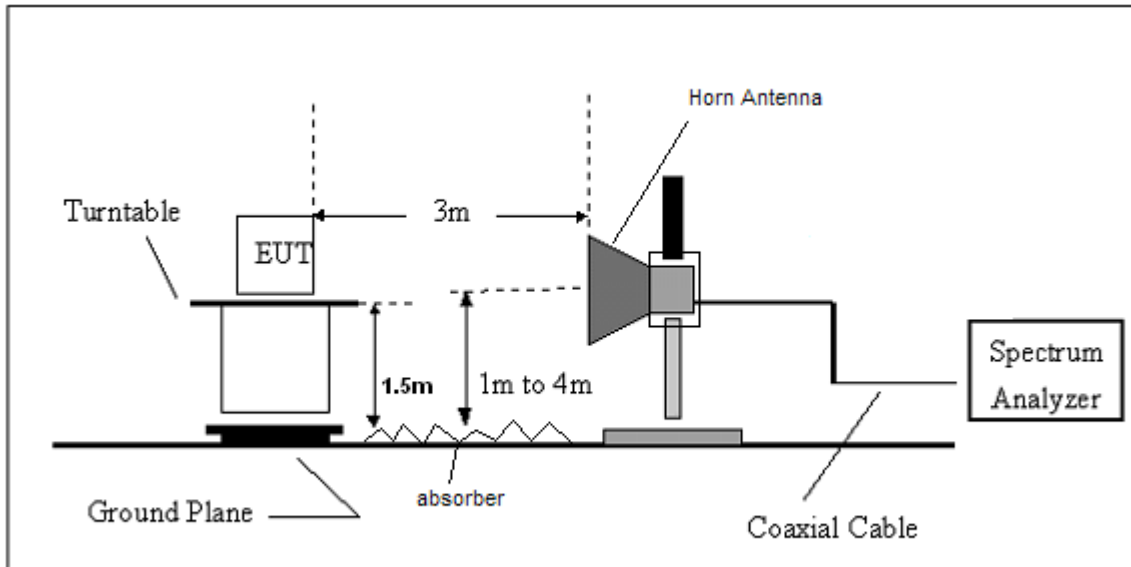

**3.3.5 TEST RESULTS (BLOW 30MHz)**

EUT :	Door window sensor	Model Name. :	ZW1101
Temperature :	20 °C	Relative Humidity :	48%
Pressure :	1010 hPa	Test Voltage :	DC 3V
Test Mode :	TX	Polarization :	--

Freq.	Reading	Limit	Margin	State
(MHz)	(dBuV/m)	(dBuV/m)	(dB)	P/F
--	--	--	--	PASS
--	--	--	--	PASS

NOTE:

The amplitude of spurious emissions which are attenuated by more than 20dB below the permissible value has no need to be reported.

Distance extrapolation factor = $40 \log(\text{specific distance}/\text{test distance})$ (dB);

Limit line = specific limits(dBuv) + distance extrapolation factor.



3.3.6 TEST RESULTS (BETWEEN 30 – 1000 MHZ)

EUT :	Door window sensor	Model Name :	ZW1101
Temperature :	20 °C	Relative Humidity :	48%
Pressure :	1010 hPa	Test Voltage :	DC 3V
Test Mode :	TX	Polarization :	Vertical

Frequency (MHz)	Meter Reading (dBµV)	Factor (dB)	Emission Level (dBµV/m)	Limits (dBµV/m)	Margin (dB)	Detector Type
43.9658	38.62	-15.35	23.27	40	-16.73	QP
139.8508	39.32	-14.38	24.94	43.5	-18.56	QP
159.2251	40.1	-13.82	26.28	43.5	-17.22	QP
170.1948	37.24	-14.4	22.84	43.5	-20.66	QP
256.5211	41.52	-14.75	26.77	46	-19.23	QP
266.6089	41.15	-14.37	26.78	46	-19.22	QP

Remark:

1. Factor = Antenna Factor + Cable Loss – Pre-amplifier.

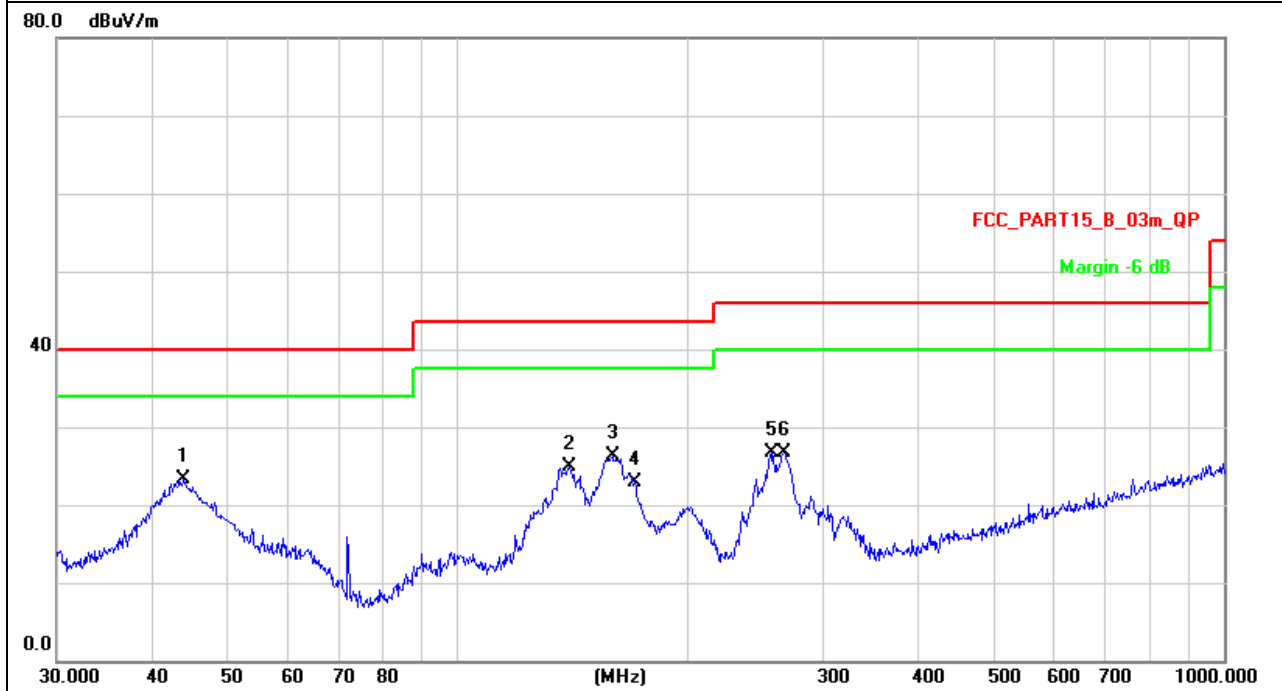



EUT :	Door window sensor	Model Name :	ZW1101
Temperature :	20 °C	Relative Humidity :	48%
Pressure :	1010 hPa	Test Voltage :	DC 3V
Test Mode :	TX	Polarization :	Horizontal

Frequency (MHz)	Meter Reading (dBμV)	Factor (dB)	Emission Level (dBμV/m)	Limits (dBμV/m)	Margin (dB)	Detector Type
54.0711	35.61	-15.65	19.96	40	-20.04	QP
140.3421	38.9	-14.35	24.55	43.5	-18.95	QP
197.8928	39.92	-16.93	22.99	43.5	-20.51	QP

Remark:

1. Factor = Antenna Factor + Cable Loss – Pre-amplifier.

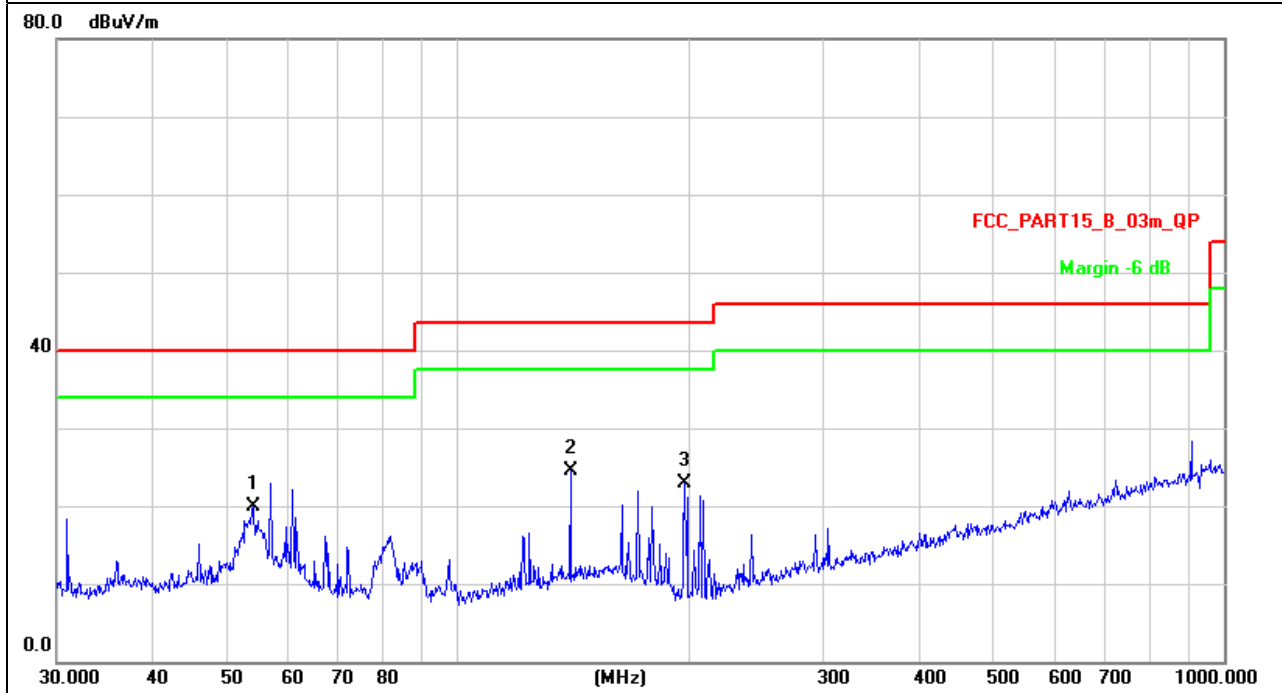



Horizontal

Freq. (MHz)	Reading (dBuV)	AF (dB/m)	Cable Loss (dB)	Pre-amp (dB)	Filter (dB)	Level (dBuv/m)	Limit (dBuv/m)	Margin (dB)	Mark (P/Q/A)
908.48	82.23	23.15	5.95	24.41	0	86.92	94	-7.08	P

Vertical

Freq. (MHz)	Reading (dBuV)	AF (dB/m)	Cable Loss (dB)	Pre-amp (dB)	Filter (dB)	Level (dBuv/m)	Limit (dBuv/m)	Margin (dB)	Mark (P/Q/A)
908.48	81.08	23.15	5.95	24.41	0	85.77	94	-8.23	P

Remark:

Margin (dB) = Remark result (dBuV/m) – Quasi-peak limit (dBuV/m).

Due to the PK results are less than the QP limit already, the QP measurement is not required

**3.3.7 TEST RESULTS (ABOVE 1000 MHZ)**

Horizontal

Freq. (MHz)	Reading (dBuV)	AF (dB/m)	Cable Loss (dB)	Pre-amp (dB)	Filter (dB)	Level (dBuV/m)	Limit (dBuV/m)	Margin (dB)	Mark (P/Q/A)
1816.75	64.02	29.02	2.21	48.33	0.3	47.22	54	-6.78	P
2725.13	54.99	30.01	2.77	47.29	0.3	40.78	54	-13.22	P
3633.6	53.02	29.99	3.23	47.6	0.3	38.94	54	-15.06	P
4541.9	53.89	32.89	3.66	48.28	0.4	42.56	54	-11.44	P
N/A	---	---	---	---	---	---	---	---	--

Vertical

Freq. (MHz)	Reading (dBuV)	AF (dB/m)	Cable Loss (dB)	Pre-amp (dB)	Filter (dB)	Level (dBuV/m)	Limit (dBuV/m)	Margin (dB)	Mark (P/Q/A)
1816.75	65.22	29.02	2.21	48.33	0.3	48.42	54	-5.58	P
2725.13	52.51	30.01	2.77	47.29	0.3	38.3	54	-15.7	P
3633.6	51.05	29.99	3.23	47.6	0.3	36.97	54	-17.03	P
4541.9	55.22	32.89	3.66	48.28	0.4	43.89	54	-10.11	P
N/A	---	---	---	---	---	---	---	---	--

Remark:

1. Measuring frequencies from 1 GHz to the 10th harmonic of highest fundamental frequency.
2. Radiated emissions measured in frequency above 1000MHz were made with an instrument using peak/average detector mode.
3. Average test would be performed if the peak result were greater than the average limit or as required by the applicant.
4. Data of measurement within this frequency range shown " --- " in the table above means the reading of emissions are attenuated more than 20dB below the permissible limits or the field strength is too small to be measured.
5. Measurements above show only up to 6 maximum emissions noted, or would be lesser, with " N/A " remark, if no specific emissions from the EUT are recorded (ie: margin>20dB from the applicable limit) and considered that's already beyond the background noise floor.
6. Margin (dB) = Remark result (dBuV/m) – Average limit (dBuV/m). Peak detector mode and average detector mode of the emission shown in Result column.



Band Edge Emission:

Due to the operating frequency of this EUT is 908.42MHz only, and its 20dB BW is just 71.296kHz, the Band Edge is not required because the allowed frequency band is 902~928MHz.

4. 20DB BANDWIDTH TEST

4.1 TEST PROCEDURE

The EUT was directly connected to the spectrum analyzer and antenna output port as show in the block diagram below,

The test receiver RBW set RBW =3KHz, VBW=10KHz, Sweep time set auto, detector function= Peak, trace=max hold

4.2 DEVIATION FROM STANDARD

No deviation.

4.3 TEST SETUP

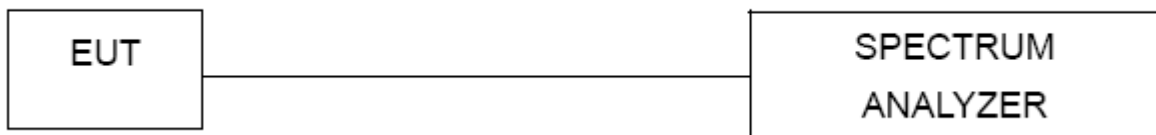



4.4 TEST RESULTS

EUT :	Door window sensor	Model Name :	ZW1101
Temperature :	26 °C	Relative Humidity :	53%
Pressure :	1020 hPa	Test Power :	DC 3V
Test Mode :	TX		

Frequency (MHz)	20 dBc Bandwidth (KHz)	99% Bandwidth (KHz)
908.42	71.296	69.0211

