

XXXXXXXX

VOICE COMMAND CONVERTER
INSTRUCTION MANUAL

Package contents and specification

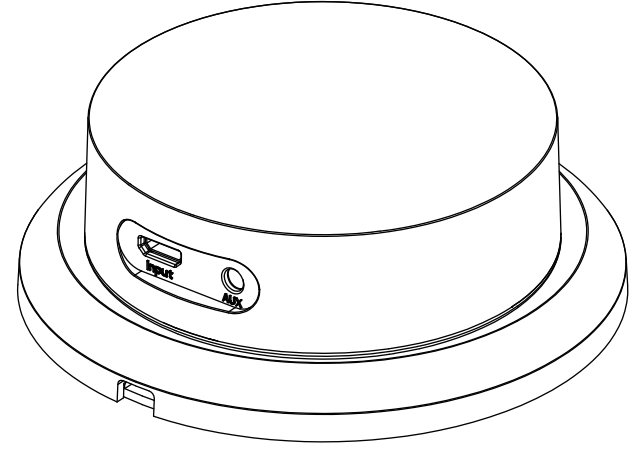
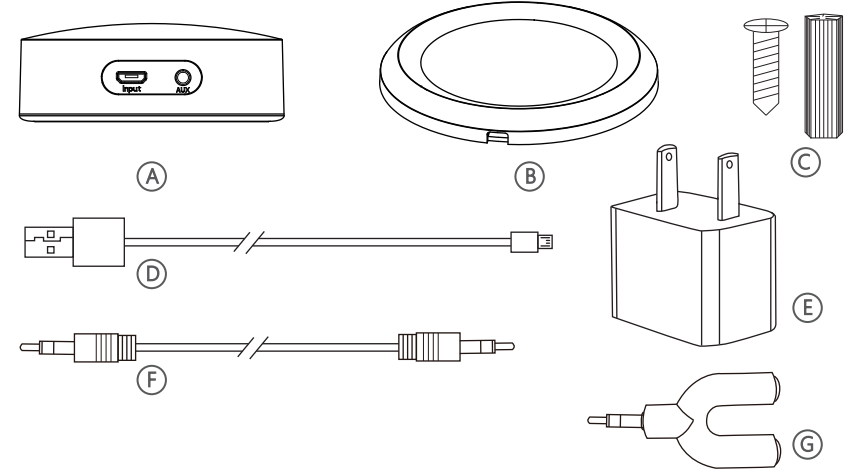

PART	DESCRIPTION	QUANTITY
A	SL 100	1
B	SL 100 Stand	1
C	Set screws plastic parts	3
D	USB	1
E	Adapter	1
F	Audio output line out	1
G	audio input to interface	1

Specification
 INPUT: 100-240V ~ 50/60Hz, 0.3A
 OUTPUT: 5V --- 1000mA
 OPERATION: Indoor/Outdoor
 OPERATING TEMPERATURE: -15° F TO 90° F (-26° C TO 32° C)
 WARRANTY: One Year Limited

Installation notes

1 Controller connection adapter as shown

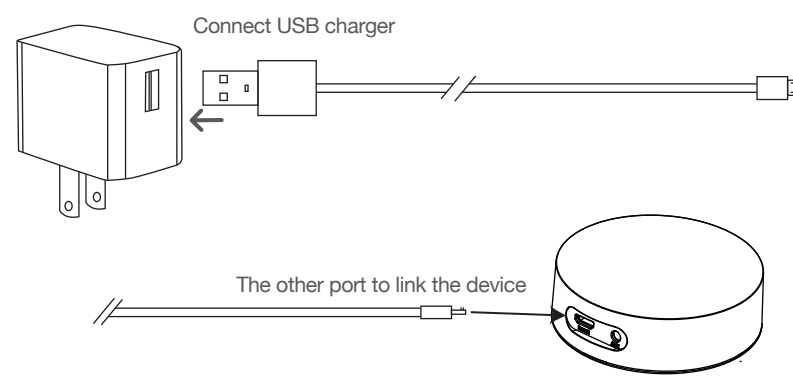

2 Connect the power adapter to the power supply

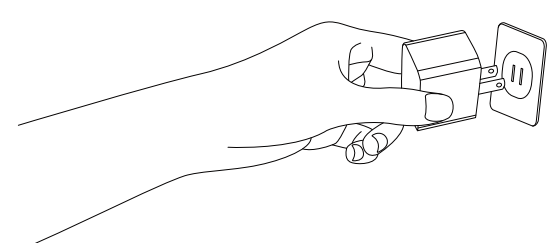

Installation notes

3 Take off SL100 stand as below show, (picture 1) 1 2 3 parts are the screw hole location insert the tool to take off the up cover

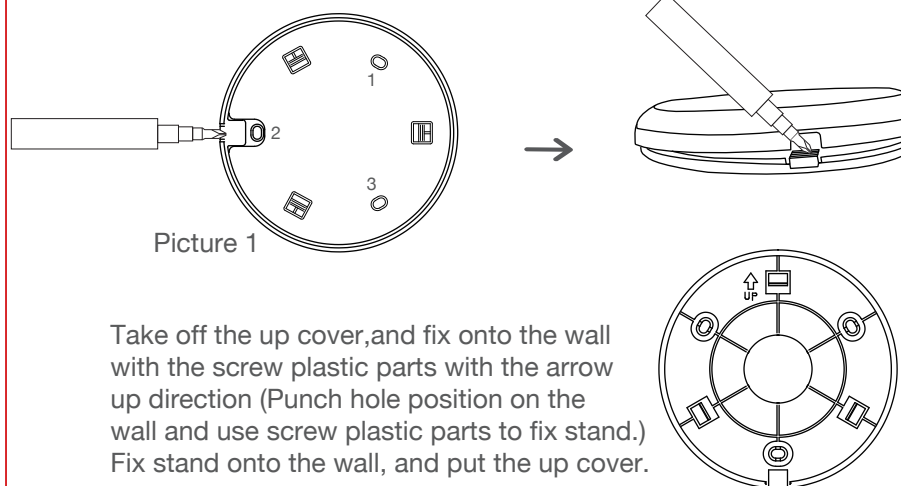

4 Put the SL100 onto the magnetic stand

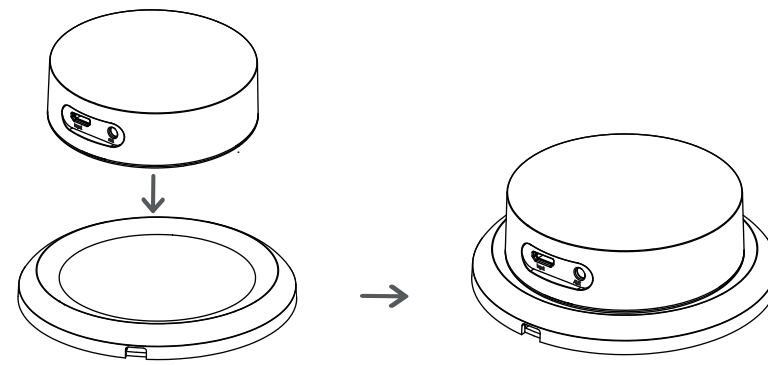

Device usage

1 STA mode (Connect your device to your phone)

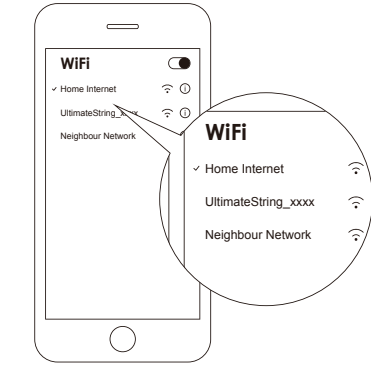

2 Connect your device to your phone via APP, turn on APP, register an account, after that, login the account, and operat as below shown

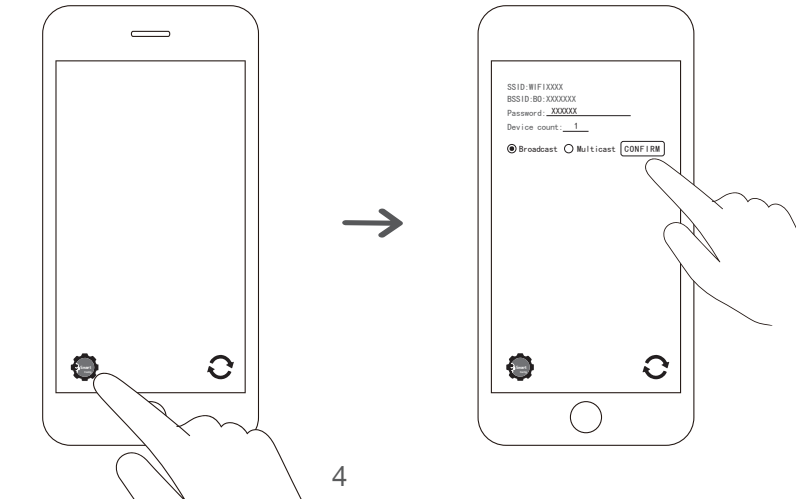

封面

Device usage

3. When the multi-color indicator light becomes blue for 1 second, and then turns off, it means STA mode connects successful and get into connection mode

2 Connect mode
Control through Google, Alexa & google voice command, when the device get the control command, the green indicator light will be on, the above 2 control mode can also control the bluetooth lights color chang

3 Off-line mode
Accident when the product in normal use, the orange indicator light of the device will be on, check the internet, when the internet get well, the device will automatic get network configuration, if success, the blue indicator will be on for 1 second, then go into the connection mode.

4 Press the Reset button for 5 seconds and recover to STA mode.

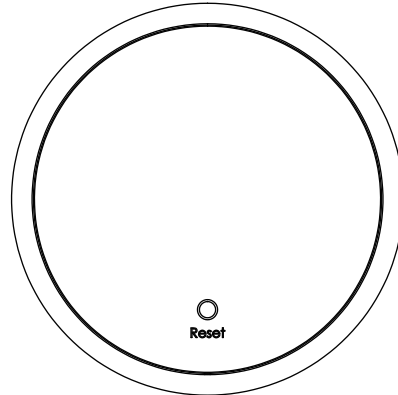

Audio input

2 Audio input operational approach

1. Put the audio input port into AUX as below shown

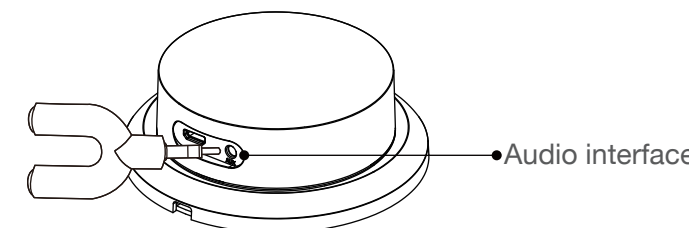

2. Connect the audio line between the SL 100 audio input interface and your phone (or other music player), then the lights will flash follow the music beat.

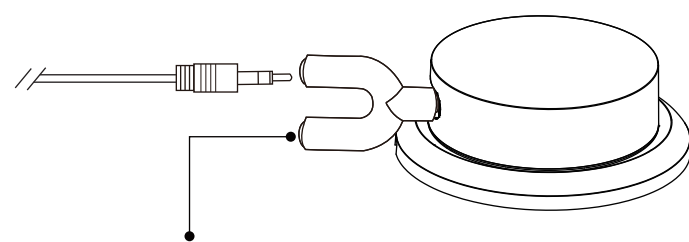

Audio output: support connecting earphones and other audio play device

FCC Caution.

This device complies with part 15 of the FCC Rules. Operation is subject to the following two conditions: (1) This device may not cause harmful interference, and (2) this device must accept any interference received, including interference that may cause undesired operation.

Any Changes or modifications not expressly approved by the party responsible for compliance could void the user's authority to operate the equipment.

Note: This equipment has been tested and found to comply with the limits for a Class B digital device, pursuant to part 15 of the FCC Rules. These limits are designed to provide reasonable protection against harmful interference in a residential installation. This equipment generates uses and can radiate radio frequency energy and, if not installed and used in accordance with the instructions, may cause harmful interference to radio communications. However, there is no guarantee that interference will not occur in a particular installation. If this equipment does cause harmful interference to radio or television reception, which can be determined by turning the equipment off and on, the user is encouraged to try to correct the interference by one or more of the following measures:
 -Reorient or relocate the receiving antenna.
 -Increase the separation between the equipment and receiver.
 -Connect the equipment into an outlet on a circuit different from that to which the receiver is connected.
 -Consult the dealer or an experienced radio/TV technician for help.

*RF warning for Mobile device:
 This equipment complies with FCC radiation exposure limits set forth for an uncontrolled environment. This equipment should be installed and operated with minimum distance 20cm between the radiator & your body.



Scan & See Me!
www.ishowtree.com

封底