



SGS-CSTC Standards Technical Services Co., Ltd. Guangzhou Branch

EMC-TRF-01 Rev 1.1

Report No.: GZCR240500044602

Page: 1 of 41

FCC ID: OWWF110655S

TEST REPORT

Application No.: GZCR2405000446AT
Applicant: Shenzhen Huaptex Co., Ltd
Address of Applicant: 3rd FL, E BLDG, Sogood Science Park, SanWei Community, Hangcheng Street, Bao'an District, Shenzhen, China
Manufacturer: Shenzhen Huaptex Co., Ltd
Address of Manufacturer: 3rd FL, E BLDG, Sogood Science Park, SanWei Community, Hangcheng Street, Bao'an District, Shenzhen, China
Factory: Shenzhen Huaptex Co., Ltd
Address of Factory: 3rd FL, E BLDG, Sogood Science Park, SanWei Community, Hangcheng Street, Bao'an District, Shenzhen, China
Product Name: Zorida Ace 3S
Model No.: F05GZ-3S-BT, F05GB-3S-BT ♣
 ♣ Please refer to section 2 of this report which indicates which model was actually tested and which were electrically identical.
Trade Mark: Zorida
Standard(s) : 47 CFR Part 2
 47 CFR Part 20
 47 CFR Part 22
 47 CFR Part 27
Date of Receipt: 2024-05-08
Date of Test: 2024-05-17 to 2024-06-13
Date of Issue: 2024-06-18

Test Result:	Pass*
---------------------	--------------

* In the configuration tested, the EUT complied with the standards specified above.

Ricky Liu
Manager



Unless otherwise agreed in writing, this document is issued by the Company subject to its General Conditions of Service printed overleaf, available on request or accessible at <https://www.sgs.com/en/Terms-and-Conditions>. Attention is drawn to the limitation of liability, indemnification and jurisdiction issues defined therein. Any holder of this document is advised that information contained hereon reflects the Company's findings at the time of its intervention only and within the limits of Client's instructions, if any. The Company's sole responsibility is to its Client and this document does not exonerate parties to a transaction from exercising all their rights and obligations under the transaction documents. This document cannot be reproduced except in full, without prior written approval of the Company. Any unauthorized alteration, forgery or falsification of the content or appearance of this document is unlawful and offenders may be prosecuted to the fullest extent of the law. Unless otherwise stated the results shown in this test report refer only to the sample(s) tested and such sample(s) are retained for 30 days only.

Attention: To check the authenticity of testing /inspection report & certificate, please contact us at telephone: (86-755) 8307 1443, or email: CN.Doccheck@sgs.com

Revision Record			
Version	Chapter	Date	Remark
01	GZCR240500044602	2024-06-18	Original

Authorized for issue by:			
	<i>Kevin Zhang</i>		
	Kevin Zhang/Project Engineer		
	<i>Jerry Chen</i>		
	Jerry Chan/Reviewer		



Unless otherwise agreed in writing, this document is issued by the Company subject to its General Conditions of Service printed overleaf, available on request or accessible at <https://www.sgs.com/en/Terms-and-Conditions>. Attention is drawn to the limitation of liability, indemnification and jurisdiction issues defined therein. Any holder of this document is advised that information contained hereon reflects the Company's findings at the time of its intervention only and within the limits of Client's instructions, if any. The Company's sole responsibility is to its Client and this document does not exonerate parties to a transaction from exercising all their rights and obligations under the transaction documents. This document cannot be reproduced except in full, without prior written approval of the Company. Any unauthorized alteration, forgery or falsification of the content or appearance of this document is unlawful and offenders may be prosecuted to the fullest extent of the law. Unless otherwise stated the results shown in this test report refer only to the sample(s) tested and such sample(s) are retained for 30 days only.

Attention: To check the authenticity of testing /inspection report & certificate, please contact us at telephone: (86-755) 8307 1443, or email: CN.Doccheck@sgs.com

2 Test Summary

Item (FCC Rule 47 CFR)	Item & Method (KDB 935210 D03 v04r04 Subclause)	Result
20.21(e)(3) Frequency Bands	7.1 Authorized frequency band verification	PASS
20.21(e)(8)(i)(D) Power Limits 20.21(e)(8)(i)(B) Bidirectional Capability	7.2 Maximum power	PASS
20.21(e)(8)(i)(C)(2) Booster Gain Limits 20.21(e)(8)(i)(B) Bidirectional Capability	7.3 Maximum booster gain computation	PASS
20.21(e)(8)(i)(F) Intermodulation Limits	7.4 Intermodulation product	PASS
20.21(e)(8)(i)(E) Out of Band Emission Limits	7.5 Out-of-band emissions	PASS
2.1051 Spurious emissions at antenna terminals	7.6 Conducted spurious emissions	PASS
20.21(e)(8)(i)(A) Noise Limits 20.21(e)(8)(i)(H) Transmit Power Off Mode	7.7 Noise limit	PASS
20.21(e)(8)(i)(I) Uplink Inactivity	7.8 Uplink inactivity	PASS
20.21(e)(8)(i)(C)(1) Booster Gain Limits 20.21(e)(8)(i)(H) Transmit Power Off Mode	7.9 Variable booster gain	PASS
2.1049 Occupied bandwidth	7.10 Occupied bandwidth	PASS
20.21(e)(8)(ii)(A) Anti-Oscillation 20.21(e)(5) Anti-Oscillation	7.11 Oscillation detection	PASS
2.1053 Field strength of spurious radiation	7.12 Radiated spurious emissions	PASS
20.21(e)(4) Self-monitoring	/	PASS



Unless otherwise agreed in writing, this document is issued by the Company subject to its General Conditions of Service printed overleaf, available on request or accessible at <https://www.sgs.com/en/Terms-and-Conditions>. Attention is drawn to the limitation of liability, indemnification and jurisdiction issues defined therein. Any holder of this document is advised that information contained hereon reflects the Company's findings at the time of its intervention only and within the limits of Client's instructions, if any. The Company's sole responsibility is to its Client and this document does not exonerate parties to a transaction from exercising all their rights and obligations under the transaction documents. This document cannot be reproduced except in full, without prior written approval of the Company. Any unauthorized alteration, forgery or falsification of the content or appearance of this document is unlawful and offenders may be prosecuted to the fullest extent of the law. Unless otherwise stated the results shown in this test report refer only to the sample(s) tested and such sample(s) are retained for 30 days only.

Attention: To check the authenticity of testing /inspection report & certificate, please contact us at telephone: (86-755) 8307 1443, or email: CN.Doccheck@sgs.com

Item (FCC Rule 47 CFR)	Item & Method (KDB 935210 D03 v04r04 Subclause)	Result
20.21(e)(8)(i)(G) Booster Antenna Kitting	/	PASS
20.21(e)(8)(i)(H) Transmit Power Off Mode	/	PASS
20.21(e)(8)(ii)(B) Gain Control	/	PASS
20.21(e)(8)(ii)(C) Interference Avoidance for Wireless Subsystems	/	PASS
20.21(e)(8)(i)(B) Bidirectional Capability 20.21(e)(3) Frequency Bands	7.13 Spectrum block filtering	PASS

Note:

E.U.T./ EUT means Equipment Under Test

Pass means the test result passed the test standard requirement, please find the detailed decision rule in the report relative section.

20.21(e)(4) Self-monitoring

There is no specific test for this functionality but it is instead indirectly addressed by the noise and gain limits tests.

20.21(e)(8)(i)(G) Booster Antenna Kitting

Generic testing requirements are not established; rather technical documentation is used describing all antennas, cables, and/or coupling devices that may be used with a consumer booster and how those meet the requirements. The related information stated in the user manual.

20.21(e)(8)(i)(H) Transmit Power Off Mode

There is no specific test for this functionality but it is instead addressed through a combination of the variable noise, variable gain, and oscillation detection tests.

20.21(e)(8)(ii)(B) Gain Control

Conformance to the requirement to include AGC circuitry is verified in 7.1 and 7.2.

20.21(e)(8)(ii)(C) Interference Avoidance for Wireless Subsystems

Before testing please submit a proposed test plan in a KDB inquiry for FCC review and acceptance. But this consumer boosters device not using unlicensed (part 15) or other frequency bands for wireless transmissions between donor and server subsystems for its internal operations, the requirement is not applicable.

20.21(e)(8)(i)(B) Bidirectional Capability

This item is only for wideband consumer booster utilizing spectrum block filtering. The device not use spectrum block filtering and the test is not applicable.



Unless otherwise agreed in writing, this document is issued by the Company subject to its General Conditions of Service printed overleaf, available on request or accessible at <https://www.sgs.com/en/Terms-and-Conditions>. Attention is drawn to the limitation of liability, indemnification and jurisdiction issues defined therein. Any holder of this document is advised that information contained hereon reflects the Company's findings at the time of its intervention only and within the limits of Client's instructions, if any. The Company's sole responsibility is to its Client and this document does not exonerate parties to a transaction from exercising all their rights and obligations under the transaction documents. This document cannot be reproduced except in full, without prior written approval of the Company. Any unauthorized alteration, forgery or falsification of the content or appearance of this document is unlawful and offenders may be prosecuted to the fullest extent of the law. Unless otherwise stated the results shown in this test report refer only to the sample(s) tested and such sample(s) are retained for 30 days only.

Attention: To check the authenticity of testing /inspection report & certificate, please contact us at telephone: (86-755) 8307 1443, or email: CN.Doccheck@sgs.com

♣ **Declaration of EUT Family Grouping:**

Model No.: F05GZ-3S-BT, F05GB-3S-BT

According to the declaration from the applicant, the electrical circuit design, layout, components used and internal wiring were identical for all models, with only differences on model No. and outer shell. Details as below.

Model No.	Outer Shell
F05GZ-3S-BT	Shell 1
F05GB-3S-BT	Shell 2

Antenna Kitting Information:

Antenna Kitting	Model	Antenna Gain and Cable loss		Remark
Log-periodic antenna	080012030	698-849MHz	8dBi	Outdoor antenna
		1710-1915MHz	9dBi	
Panel antenna	080011023	728-894MHz	8dBi	Indoor antenna
		1930-2155MHz	9dBi	
Coaxial-cable (15m)	3D-FB	600-2000MHz	-8.4dB	For outdoor use
		2000-2500MHz	-9.1dB	
Coaxial-cable (6m)	3D-FB	600-2000MHz	-3.8dB	For indoor use
		2000-2500MHz	-4.5dB	

Therefore, only one mode **F05GZ-3S-BT** was tested in this report.



Unless otherwise agreed in writing, this document is issued by the Company subject to its General Conditions of Service printed overleaf, available on request or accessible at <https://www.sgs.com/en/Terms-and-Conditions>. Attention is drawn to the limitation of liability, indemnification and jurisdiction issues defined therein. Any holder of this document is advised that information contained hereon reflects the Company's findings at the time of its intervention only and within the limits of Client's instructions, if any. The Company's sole responsibility is to its Client and this document does not exonerate parties to a transaction from exercising all their rights and obligations under the transaction documents. This document cannot be reproduced except in full, without prior written approval of the Company. Any unauthorized alteration, forgery or falsification of the content or appearance of this document is unlawful and offenders may be prosecuted to the fullest extent of the law. Unless otherwise stated the results shown in this test report refer only to the sample(s) tested and such sample(s) are retained for 30 days only.

Attention: To check the authenticity of testing /inspection report & certificate, please contact us at telephone: (86-755) 8307 1443, or email: CN.Doccheck@sgs.com

3 Contents

	Page
1 Covers Page	1
2 Test Summary	3
3 Contents	6
4 General Information.....	8
4.1 Details of EUT	8
4.2 Description of Support Units	9
4.3 Test Environment.....	9
4.4 Measurement Uncertainty	9
4.5 Test Location	9
4.6 Test Facility	10
4.7 Deviation from Standards	10
4.8 Abnormalities from Standard Conditions.....	10
5 Equipment List.....	11
6 Radio Spectrum Matter Test Result.....	13
6.1 Authorized frequency band verification	13
6.1.1 E.U.T. Operation	13
6.1.2 Test Setup	13
6.1.3 Test Procedure	14
6.1.4 Measurement Record	14
6.2 Maximum power	15
6.2.1 E.U.T. Operation	15
6.2.2 Test Setup	15
6.2.3 Test Procedure	16
6.2.4 Measurement Record	16
6.3 Maximum booster gain computation	17
6.3.1 E.U.T. Operation	17
6.3.2 Test Setup	17
6.3.3 Test procedure.....	18
6.3.4 Measurement Record	18
6.4 Intermodulation product	19
6.4.1 E.U.T. Operation	19
6.4.2 Test Setup	19
6.4.3 Test procedure.....	20
6.4.4 Measurement Record	20
6.5 Out-of-band emissions	21
6.5.1 E.U.T. Operation	22
6.5.2 Test Setup	22
6.5.3 Test procedure.....	22
6.5.4 Measurement Record	23
6.6 Conducted spurious emissions	24
6.6.1 E.U.T. Operation	24



Unless otherwise agreed in writing, this document is issued by the Company subject to its General Conditions of Service printed overleaf, available on request or accessible at <https://www.sgs.com/en/Terms-and-Conditions>. Attention is drawn to the limitation of liability, indemnification and jurisdiction issues defined therein. Any holder of this document is advised that information contained hereon reflects the Company's findings at the time of its intervention only and within the limits of Client's instructions, if any. The Company's sole responsibility is to its Client and this document does not exonerate parties to a transaction from exercising all their rights and obligations under the transaction documents. This document cannot be reproduced except in full, without prior written approval of the Company. Any unauthorized alteration, forgery or falsification of the content or appearance of this document is unlawful and offenders may be prosecuted to the fullest extent of the law. Unless otherwise stated the results shown in this test report refer only to the sample(s) tested and such sample(s) are retained for 30 days only.

Attention: To check the authenticity of testing /inspection report & certificate, please contact us at telephone: (86-755) 8307 1443, or email: CN.Doccheck@sgs.com

6.6.2	Test Setup	24
6.6.3	Test procedure.....	24
6.6.4	Measurement Record	25
6.7	Noise limit	26
6.7.1	E.U.T. Operation	26
6.7.2	Test Setup	26
6.7.3	Test procedure.....	27
6.7.4	Measurement Record	28
6.8	Uplink inactivity	29
6.8.1	E.U.T. Operation	29
6.8.2	Test Setup	29
6.8.3	Test procedure.....	29
6.8.4	Measurement Record	29
6.9	Variable booster gain	30
6.9.1	E.U.T. Operation	30
6.9.2	Test Setup	30
6.9.3	Test procedure.....	31
6.9.4	Measurement Record	31
6.10	Occupied bandwidth	32
6.10.1	E.U.T. Operation.....	32
6.10.2	Test Setup	32
6.10.3	Test procedure	33
6.10.4	Measurement Record.....	33
6.11	Oscillation detection	34
6.11.1	E.U.T. Operation.....	34
6.11.2	Test Setup	35
6.11.3	Test procedure	36
6.11.4	Measurement Record.....	38
6.12	Radiated spurious emissions	39
6.12.1	E.U.T. Operation.....	39
6.12.2	Test Setup	39
6.12.3	Test procedure	40
6.12.4	Measurement Record.....	40
7	Test Setup Photographs	41
8	EUT Constructional Details (EUT Photos)	41



Unless otherwise agreed in writing, this document is issued by the Company subject to its General Conditions of Service printed overleaf, available on request or accessible at <https://www.sgs.com/en/Terms-and-Conditions>. Attention is drawn to the limitation of liability, indemnification and jurisdiction issues defined therein. Any holder of this document is advised that information contained hereon reflects the Company's findings at the time of its intervention only and within the limits of Client's instructions, if any. The Company's sole responsibility is to its Client and this document does not exonerate parties to a transaction from exercising all their rights and obligations under the transaction documents. This document cannot be reproduced except in full, without prior written approval of the Company. Any unauthorized alteration, forgery or falsification of the content or appearance of this document is unlawful and offenders may be prosecuted to the fullest extent of the law. Unless otherwise stated the results shown in this test report refer only to the sample(s) tested and such sample(s) are retained for 30 days only.

Attention: To check the authenticity of testing /inspection report & certificate, please contact us at telephone: (86-755) 8307 1443, or email: CN.Doccheck@sgs.com

4 General Information

4.1 Details of EUT

Power Supply:	AC 100-240V, 50/60Hz by AC/DC adapter												
	Model: RJ23-W120150US												
	Input: 100-240V, 50/60Hz 0.8A												
	Output: 12V--1.5A												
Test Voltage:	AC 120V												
Cable:	DC output cable (unshielded, 2m)												
Operating Temperature:	-25 to +55 °C												
Operating Frequency:	<table border="0"> <tr> <td>Lower 700MHz</td> <td>Uplink: 698MHz to 716MHz</td> </tr> <tr> <td></td> <td>Downlink: 728MHz to 746MHz</td> </tr> <tr> <td>Upper 700MHz</td> <td>Uplink: 776MHz to 787MHz</td> </tr> <tr> <td></td> <td>Downlink: 746MHz to 757MHz</td> </tr> <tr> <td>Cellular</td> <td>Uplink: 824MHz to 849MHz</td> </tr> <tr> <td></td> <td>Downlink: 869MHz to 894MHz</td> </tr> </table>	Lower 700MHz	Uplink: 698MHz to 716MHz		Downlink: 728MHz to 746MHz	Upper 700MHz	Uplink: 776MHz to 787MHz		Downlink: 746MHz to 757MHz	Cellular	Uplink: 824MHz to 849MHz		Downlink: 869MHz to 894MHz
Lower 700MHz	Uplink: 698MHz to 716MHz												
	Downlink: 728MHz to 746MHz												
Upper 700MHz	Uplink: 776MHz to 787MHz												
	Downlink: 746MHz to 757MHz												
Cellular	Uplink: 824MHz to 849MHz												
	Downlink: 869MHz to 894MHz												
Technology:	GSM, WCDMA, LTE												
Interface:	RF Port: 2 (N-F)												
	Power Jack: 1												
Output Power:	Uplink: ≥17dBm												
(Conducted)	Downlink: ≤11dBm												
Max. Gain:	Uplink: ≤65dB												
	Downlink: ≤65dB												
Antenna Type:	External Dedicated Antenna												
Antenna Gain:	Refer to clause 2 in this report												
Software Version:	F05GZ-3S-BT_V1.0												
Booster Type:	Fixed Consumer Signal Booster												
Bluetooth:	Refer to Bluetooth Module FCC ID: 2ATPO-PB03												
Remark:	The information in this section is provided by the applicant or manufacturer, SGS is not liable to the accuracy, suitability, reliability or/and integrity of the information.												



Unless otherwise agreed in writing, this document is issued by the Company subject to its General Conditions of Service printed overleaf, available on request or accessible at <https://www.sgs.com/en/Terms-and-Conditions>. Attention is drawn to the limitation of liability, indemnification and jurisdiction issues defined therein. Any holder of this document is advised that information contained hereon reflects the Company's findings at the time of its intervention only and within the limits of Client's instructions, if any. The Company's sole responsibility is to its Client and this document does not exonerate parties to a transaction from exercising all their rights and obligations under the transaction documents. This document cannot be reproduced except in full, without prior written approval of the Company. Any unauthorized alteration, forgery or falsification of the content or appearance of this document is unlawful and offenders may be prosecuted to the fullest extent of the law. Unless otherwise stated the results shown in this test report refer only to the sample(s) tested and such sample(s) are retained for 30 days only.

Attention: To check the authenticity of testing /inspection report & certificate, please contact us at telephone: (86-755) 8307 1443, or email: CN.Doccheck@sgs.com

4.2 Description of Support Units

Mathced load and attenuator supplied by the client.

4.3 Test Environment

Environment Parameter	Selected Values During Test	
Relative Humidity	Ambient	
Value	Temperature (°C)	Voltage (V)
TNVN	25	AC 120V

VN: Normal Voltage

TN: Normal Teperature

4.4 Measurement Uncertainty

No.	Item	Measurement Uncertainty
1	RF Output Power	±0.75dB
2	Transmitter unwanted emissions	±0.75dB
3	Radiated Spurious Emission	±5.06dB (30MHz-1GHz; 3m); ±4.46dB (30MHz-1GHz; 10m); ±5.08dB (1GHz-6GHz); ±5.14dB (6GHz-18GHz)
4	Occupied Channel Bandwidth	± 3%

4.5 Test Location

All tests were performed at:

SGS-CSTC Standards Technical Services Co., Ltd., Guangzhou Branch EMC Laboratory,
198 Kezhu Road, Sciencetech Park, Guangzhou Economic & Technology Development District,
Guangzhou, China 510663

Tel: +86 20 82155555

Fax: +86 20 82075059



Unless otherwise agreed in writing, this document is issued by the Company subject to its General Conditions of Service printed overleaf, available on request or accessible at <https://www.sgs.com/en/Terms-and-Conditions>. Attention is drawn to the limitation of liability, indemnification and jurisdiction issues defined therein. Any holder of this document is advised that information contained hereon reflects the Company's findings at the time of its intervention only and within the limits of Client's instructions, if any. The Company's sole responsibility is to its Client and this document does not exonerate parties to a transaction from exercising all their rights and obligations under the transaction documents. This document cannot be reproduced except in full, without prior written approval of the Company. Any unauthorized alteration, forgery or falsification of the content or appearance of this document is unlawful and offenders may be prosecuted to the fullest extent of the law. Unless otherwise stated the results shown in this test report refer only to the sample(s) tested and such sample(s) are retained for 30 days only.

Attention: To check the authenticity of testing /inspection report & certificate, please contact us at telephone: (86-755) 8307 1443, or email: CN.Doccheck@sgs.com

4.6 Test Facility

The test facility is recognized, certified, or accredited by the following organizations:

- **ACMA**

SGS-CSTC Standards Technical Services Co., Ltd., EMC Laboratory can also perform testing for the Australian/New Zealand Regulatory Compliance Mark (RCM).

- **SGS UK(Certificate No.: 32), SGS-TUV SAARLAND and SGS-FIMKO**

Have approved SGS-CSTC Standards Technical Services Co., Ltd., EMC Laboratory as a supplier of EMC TESTING SERVICES and SAFETY TESTING SERVICES.

- **FCC Recognized Accredited Test Firm(Registration No.: 486818)**

SGS-CSTC Standards Technical Services Co., Ltd., EMC Laboratory has been accredited and fully described in a report filed with the (FCC) Federal Communications Commission. The acceptance letter from the FCC is maintained in our files. Designation Number: CN5016, Test Firm Registration Number: 486818.

- **ISED (Registration No.: 4620B, CAB identifier: CN0052)**

SGS-CSTC Standards Technical Services Co., Ltd., has been registered by Innovation Science and Economic Development Canada for Wireless Device Testing laboratories to test to Canadian radio equipment requirements. Registration No. 4620B, CAB identifier: CN0052.

- **VCCI (Registration No.: R-12460, C-12584, G-20107 and T-11179)**

The 10m Semi-anechoic chamber, 966 Anechoic Chamber and Shielded Room of SGS-CSTC Standards Technical Services Co., Ltd. have been registered in accordance with the Regulations for Voluntary Control Measures with Registration No.: R-12460, C-12584, G-20107 and T-11179 respectively.

- **CBTL (Lab Code: TL129)**

SGS-CSTC Standards Technical Services Co., Ltd., E&E Laboratory has been assessed and fully comply with the requirements of ISO/IEC 17025:2017, the Basic Rules, IECEE 01 and Rules of procedure IECEE 02, and the relevant IECEE CB-Scheme Operational documents.

4.7 Deviation from Standards

None

4.8 Abnormalities from Standard Conditions

None



Unless otherwise agreed in writing, this document is issued by the Company subject to its General Conditions of Service printed overleaf, available on request or accessible at <https://www.sgs.com/en/Terms-and-Conditions>. Attention is drawn to the limitation of liability, indemnification and jurisdiction issues defined therein. Any holder of this document is advised that information contained hereon reflects the Company's findings at the time of its intervention only and within the limits of Client's instructions, if any. The Company's sole responsibility is to its Client and this document does not exonerate parties to a transaction from exercising all their rights and obligations under the transaction documents. This document cannot be reproduced except in full, without prior written approval of the Company. Any unauthorized alteration, forgery or falsification of the content or appearance of this document is unlawful and offenders may be prosecuted to the fullest extent of the law. Unless otherwise stated the results shown in this test report refer only to the sample(s) tested and such sample(s) are retained for 30 days only.

Attention: To check the authenticity of testing /inspection report & certificate, please contact us at telephone: (86-755) 8307 1443, or email: CN.Doccheck@sgs.com

5 Equipment List

Conducted test equipment					
Equipment	Manufacturer	Model No	Inventory No	Cal Date	Cal Due Date
Temperature Chamber	GZ GongWen Co.Ltd.	GDJW-100	EMC0039	2023-06-29	2024-06-28
MI CABLE	SGS-EMC	0.8M	EMC2137	2023-11-02	2025-11-01
MI CABLE	SGS-EMC	0.8M	EMC2136	2023-11-02	2025-11-01
EXA Signal Analyzer (10Hz-44GHz)	Keysight	N9010A	EMC2138	2023-08-23	2024-08-22
MXA Signal Analyzer (10Hz-50GHz)	KEYSIGHT	N9020B	SEM004-24	2024-03-16	2025-03-15
4X4 Power Sensor Unit	TST	TSPS2023R	EMC2257	2023-08-23	2024-08-22
Test Software	TST	V2.0	GZE100-78	N/A	N/A
ESG vector signal generator (250kHz-6GHz)	Agilent Technologies	E4438C	SEM006-03	2024-02-19	2025-02-18

Radiated test equipment (30MHz to 1GHz)					
Equipment	Manufacturer	Model No	Inventory No	Cal Date	Cal Due Date
10m Semi-Anechoic Chamber	ETS	N/A	EMC0530	2022-10-16	2025-10-15
Chamber cable	HangTianXing	N/A	EMC0542	2023-06-14	2025-06-13
Amplifier (9kHz-1.3GHz)	HP	8447F	EMC2065	2023-06-14	2024-06-13
EMI Test Receiver (1Hz-8GHz)	Rohde & Schwarz	ESW8	EMC2220	2024-05-13	2025-05-12
Test Software E3	Audix	Ver.6.120110a	GZE100-61	N/A	N/A
Trilog Broadband Antenna (25MHz-1GHz)	SCHWARZBECK MESS-ELEKTRONIK	VULB 9168	EMC2174	2022-06-19	2025-06-18
TRILOG Broadband Antenna (25M-2GHz)	SCHWARZBECK	VULB 9168	SEM003-18	2022-03-03	2025-03-02



Unless otherwise agreed in writing, this document is issued by the Company subject to its General Conditions of Service printed overleaf, available on request or accessible at <https://www.sgs.com/en/Terms-and-Conditions>. Attention is drawn to the limitation of liability, indemnification and jurisdiction issues defined therein. Any holder of this document is advised that information contained hereon reflects the Company's findings at the time of its intervention only and within the limits of Client's instructions, if any. The Company's sole responsibility is to its Client and this document does not exonerate parties to a transaction from exercising all their rights and obligations under the transaction documents. This document cannot be reproduced except in full, without prior written approval of the Company. Any unauthorized alteration, forgery or falsification of the content or appearance of this document is unlawful and offenders may be prosecuted to the fullest extent of the law. Unless otherwise stated the results shown in this test report refer only to the sample(s) tested and such sample(s) are retained for 30 days only.

Attention: To check the authenticity of testing /inspection report & certificate, please contact us at telephone: (86-755) 8307 1443, or email: CN.Doccheck@sgs.com

Radiated test equipment (above 1GHz)					
Equipment	Manufacturer	Model No	Inventory No	Cal Date	Cal Due Date
1GHz-26.5 GHz Pre-Amplifier	Agilent	8449B	EMC0521	2023-11-10	2024-11-09
Microwave Broadband Preamplifier (18-40GHz)	SCHWARZBECK	BBV 9721	EMC2172	2023-08-21	2024-08-20
EMI Test Receiver (10Hz-26.5GHz)	Rohde & Schwarz	ESIB26	EMC0522	2023-12-15	2024-12-14
EXA Signal Analyzer (10Hz-44GHz)	Keysight	N9010A	EMC2138	2023-08-23	2024-08-22
Chamber cable (Above 1GHz)	Scoflex	KMKM-8.0m	EMC0545	2022-08-24	2024-08-23
Chamber Cable (Below 1GHz)	Scoflex	KMKM-8.0m	EMC0546	2022-08-24	2024-08-23
Trilog Broadband Antenna (25MHz-1GHz)	SCHWARZBECK	VULB 9160	EMC2025	2022-09-07	2025-09-06
Horn Antenna (1GHz-18GHz)	SCHWARZBECK MESS-ELEKTRONIK	BBHA 9120D	EMC2026	2022-09-21	2025-09-20
Horn Antenna 1-18GHz	SCHWARZBECK MESS-ELEKTRONIK	BBHA 9120D	EMC2251	2022-02-02	2025-08-01
Horn Antenna (14-40GHz)	SCHWARZBECK	BBHA 9170	EMC2041	2023-06-18	2026-06-17
Broad-Band Horn Antenna (15-40GHz)	Schwarzbeck	BBHA 9170	SEM003-15	2021-07-11	2024-07-10
966 Anechoic Chamber	C.R.T	9m x 6m x 6m	EMC2142	2023-12-23	2026-12-22
Test Software E3	Audix	Ver.6.120110a	GZE100-61	N/A	N/A



Unless otherwise agreed in writing, this document is issued by the Company subject to its General Conditions of Service printed overleaf, available on request or accessible at <https://www.sgs.com/en/Terms-and-Conditions>. Attention is drawn to the limitation of liability, indemnification and jurisdiction issues defined therein. Any holder of this document is advised that information contained hereon reflects the Company's findings at the time of its intervention only and within the limits of Client's instructions, if any. The Company's sole responsibility is to its Client and this document does not exonerate parties to a transaction from exercising all their rights and obligations under the transaction documents. This document cannot be reproduced except in full, without prior written approval of the Company. Any unauthorized alteration, forgery or falsification of the content or appearance of this document is unlawful and offenders may be prosecuted to the fullest extent of the law. Unless otherwise stated the results shown in this test report refer only to the sample(s) tested and such sample(s) are retained for 30 days only.

Attention: To check the authenticity of testing /inspection report & certificate, please contact us at telephone: (86-755) 8307 1443, or email: CN.Doccheck@sgs.com

6 Radio Spectrum Matter Test Result

6.1 Authorized frequency band verification

Test Requirement: 47 CFR Part 20.21(e)(3)

Test Method: KDB 935210 D03 clause 7.1

Limit: *20.21(e)(3) Frequency Bands:*

Consumer Signal Boosters must be designed and manufactured such that they only operate on the frequencies used for the provision of subscriber-based services under parts 22 (Cellular), 24 (Broadband PCS), 27 (AWS-1, 700 MHz Lower A-E Blocks, and 700 MHz Upper C Block), and 90 (Specialized Mobile Radio).

6.1.1 E.U.T. Operation

Operating Environment:

Temperature: 24.9 °C Humidity: 58 % RH Atmospheric Pressure: 1008 mbar

Test Mode: Set the EUT to maximum output power and maximum gain.

6.1.2 Test Setup

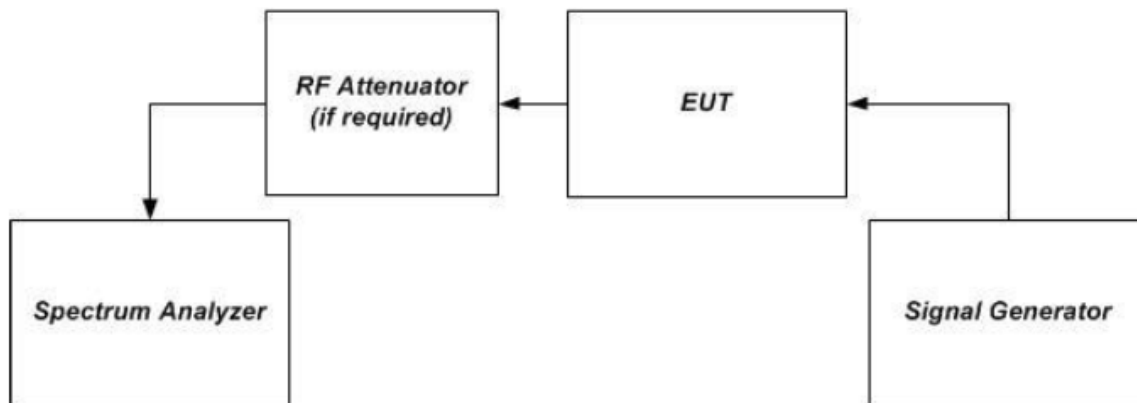

Unless otherwise agreed in writing, this document is issued by the Company subject to its General Conditions of Service printed overleaf, available on request or accessible at <https://www.sgs.com/en/Terms-and-Conditions>. Attention is drawn to the limitation of liability, indemnification and jurisdiction issues defined therein. Any holder of this document is advised that information contained hereon reflects the Company's findings at the time of its intervention only and within the limits of Client's instructions, if any. The Company's sole responsibility is to its Client and this document does not exonerate parties to a transaction from exercising all their rights and obligations under the transaction documents. This document cannot be reproduced except in full, without prior written approval of the Company. Any unauthorized alteration, forgery or falsification of the content or appearance of this document is unlawful and offenders may be prosecuted to the fullest extent of the law. Unless otherwise stated the results shown in this test report refer only to the sample(s) tested and such sample(s) are retained for 30 days only.

Attention: To check the authenticity of testing /inspection report & certificate, please contact us at telephone: (86-755) 8307 1443, or email: CN.Doccheck@sgs.com

6.1.3 Test Procedure

- a) Connect the EUT to the test equipment as shown in Test Setup. Begin with the uplink output (donor) port connected to the spectrum analyzer.
- b) Set the spectrum analyzer resolution bandwidth (RBW) for 100 kHz with the video bandwidth (VBW) $\geq 3 \times$ the RBW, using a PEAK detector with the MAX HOLD function.
- c) Set the center frequency of the spectrum analyzer to the center of the operational band under test with a span of 1 MHz.
- d) Set the signal generator for CW mode and tune to the center frequency of the operational band under test.
- e) Set the initial signal generator power to a level that is at least 6 dB below the AGC level specified by the manufacturer.
- f) Slowly increase the signal generator power level until the output signal reaches the AGC operational level.
- g) Reduce the signal generator power to a level that is 3 dB below the level noted above, then manually reset the EUT (e.g., cycle ac/dc power).
- h) Reset the spectrum analyzer span to $2 \times$ the width of the CMRS band under test. Adjust the tuned frequency of the signal generator to sweep $2 \times$ the width of the CMRS band using the sweep function. The AGC must be deactivated throughout the entire sweep.
- i) Using three markers, identify the CMRS band edges and the frequency with the highest power. Affirm that the values of all markers are visible on the display of the spectrum analyzer (e.g., marker table set to on).
- j) Capture the spectrum analyzer trace for inclusion in the test report.
- k) Repeat 7.1c) to 7.1j) for all operational uplink and downlink bands.

6.1.4 Measurement Record

Please refer to Appendix - Test Data and Result for report GZCR240500044602.



Unless otherwise agreed in writing, this document is issued by the Company subject to its General Conditions of Service printed overleaf, available on request or accessible at <https://www.sgs.com/en/Terms-and-Conditions>. Attention is drawn to the limitation of liability, indemnification and jurisdiction issues defined therein. Any holder of this document is advised that information contained hereon reflects the Company's findings at the time of its intervention only and within the limits of Client's instructions, if any. The Company's sole responsibility is to its Client and this document does not exonerate parties to a transaction from exercising all their rights and obligations under the transaction documents. This document cannot be reproduced except in full, without prior written approval of the Company. Any unauthorized alteration, forgery or falsification of the content or appearance of this document is unlawful and offenders may be prosecuted to the fullest extent of the law. Unless otherwise stated the results shown in this test report refer only to the sample(s) tested and such sample(s) are retained for 30 days only.

Attention: To check the authenticity of testing /inspection report & certificate, please contact us at telephone: (86-755) 8307 1443, or email: CN.Doccheck@sgs.com

6.2 Maximum power

Test Requirement: 47 CFR Part 20.21(e)(8)(i)(D), 20.21(e)(8)(i)(B), 20.21(e)(4)

Test Method: KDB 935210 D03 clause 7.2

Limit: *20.21(e)(8)(i)(D) Power Limit:*

A booster's uplink power must not exceed 1 watt composite conducted power and equivalent isotropic radiated power (EIRP) for each band of operation. Composite downlink power shall not exceed 0.05 watt (17 dBm) conducted and EIRP for each band of operation.

20.21(e)(8)(i)(B) Bidirectional Capability:

Consumer Boosters must be able to provide equivalent uplink and downlink gain and conducted uplink power output that is at least 0.05 watts.

6.2.1 E.U.T. Operation

Operating Environment:

Temperature: 24.9 °C Humidity: 58 % RH Atmospheric Pressure: 1008 mbar

Test Mode: Set the EUT to maximum output power and maximum gain.

6.2.2 Test Setup

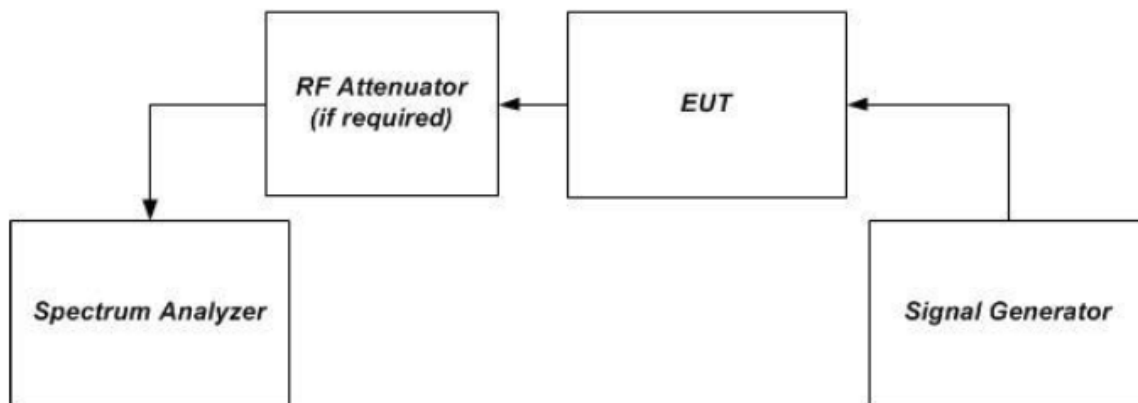

Unless otherwise agreed in writing, this document is issued by the Company subject to its General Conditions of Service printed overleaf, available on request or accessible at <https://www.sgs.com/en/Terms-and-Conditions>. Attention is drawn to the limitation of liability, indemnification and jurisdiction issues defined therein. Any holder of this document is advised that information contained hereon reflects the Company's findings at the time of its intervention only and within the limits of Client's instructions, if any. The Company's sole responsibility is to its Client and this document does not exonerate parties to a transaction from exercising all their rights and obligations under the transaction documents. This document cannot be reproduced except in full, without prior written approval of the Company. Any unauthorized alteration, forgery or falsification of the content or appearance of this document is unlawful and offenders may be prosecuted to the fullest extent of the law. Unless otherwise stated the results shown in this test report refer only to the sample(s) tested and such sample(s) are retained for 30 days only.

Attention: To check the authenticity of testing /inspection report & certificate, please contact us at telephone: (86-755) 8307 1443, or email: CN.Doccheck@sgs.com

6.2.3 Test Procedure

- a) Connect the EUT to the test equipment as shown in Figure 1. Begin with the uplink output (donor) port connected to the spectrum analyzer.
- b) Configure the signal generator and spectrum analyzer for operation on the frequency determined in 7.1 with the highest power level, but with the center frequency of the signal no closer than 2.5 MHz from the band edge. The spectrum analyzer span shall be set to at least 10 MHz.
- c) Set the initial signal generator power to a level well below that which causes AGC activation.
- d) Slowly increase the signal generator power level until the output signal reaches the AGC operational limit (from observation of signal behavior on the spectrum analyzer; i.e., no further increase in output power as input power is increased).
- e) Reduce power sufficiently on the signal generator to ensure that the AGC is not controlling the power output.
- f) Slowly increase the signal generator power to a level just below (and within 0.5 dB of) the AGC limit without triggering the AGC. Note the signal generator power level as P_{in} .
- g) Measure the output power, P_{out} , with the spectrum analyzer as follows.
 - 1) Set RBW = 100 kHz for AWGN signal type, or 300 kHz for CW or GSM signal type.
 - 2) Set VBW $\geq 3 \times$ RBW.
 - 3) Select either the BURST POWER or CHANNEL POWER measurement mode, as required for each signal type. For AWGN, the channel power integration bandwidth shall be the 99% OBW of the 4.1 MHz signal.
 - 4) Select the power averaging (rms) detector.
 - 5) Affirm that the number of measurement points per sweep $\geq (2 \times \text{span})/\text{RBW}$. NOTE—This requirement does not apply for BURST power measurement mode.
 - 6) Set sweep time = auto couple, or as necessary (but no less than auto couple value).
 - 7) Trace average at least 100 traces in power averaging (i.e., rms) mode.
 - 8) Record the measured power level P_{out} , with one set of results for the GSM or CW input stimulus, and another set of results for the AWGN input stimulus.
- h) Repeat step g) while increasing the signal generator amplitude in 2 dB steps until the maximum input level indicated in 5.5 is reached. If the booster has shut down at any point during the input power steps, it should be noted and step g) shall be repeated at an input level 1 dB less than that found to cause the shutdown. The test report shall include either a statement describing that the device complies at 10 dB above AGC or at the 5.5 power levels, or a table showing compliance at the additional input power(s) required.
- i) Repeat the entire procedure for each operational uplink and downlink frequency band supported by the booster.
- j) Provide tabulated results in the test report.

6.2.4 Measurement Record

Please refer to Appendix - Test Data and Result for report GZCR240500044602.



Unless otherwise agreed in writing, this document is issued by the Company subject to its General Conditions of Service printed overleaf, available on request or accessible at <https://www.sgs.com/en/Terms-and-Conditions>. Attention is drawn to the limitation of liability, indemnification and jurisdiction issues defined therein. Any holder of this document is advised that information contained hereon reflects the Company's findings at the time of its intervention only and within the limits of Client's instructions, if any. The Company's sole responsibility is to its Client and this document does not exonerate parties to a transaction from exercising all their rights and obligations under the transaction documents. This document cannot be reproduced except in full, without prior written approval of the Company. Any unauthorized alteration, forgery or falsification of the content or appearance of this document is unlawful and offenders may be prosecuted to the fullest extent of the law. Unless otherwise stated the results shown in this test report refer only to the sample(s) tested and such sample(s) are retained for 30 days only.

Attention: To check the authenticity of testing /inspection report & certificate, please contact us at telephone: (86-755) 8307 1443, or email: CN.Doccheck@sgs.com

6.3 Maximum booster gain computation

Test Requirement: 47 CFR Part 20.21(e)(8)(i)(C)(2), 20.21(e)(8)(i)(B)

Test Method: KDB 935210 D03 clause 7.3

Limit: 20.21(e)(8)(i)(C)(2) *Booster Gain limit:*

The uplink and downlink maximum gain of a Consumer Booster referenced to its input and output ports shall not exceed the following limits:

- (i) Fixed Booster maximum gain shall not exceed $6.5 \text{ dB} + 20 \text{ Log}_{10}(\text{Frequency})$
- (ii) Where, Frequency is the uplink mid-band frequency of the supported spectrum bands in MHz

20.21(e)(8)(i)(B) *Bidirectional Capability:*

Consumer Boosters be able to provide equivalent uplink and downlink gain, i.e., within 9 dB

6.3.1 E.U.T. Operation

Operating Environment:

Temperature: 24.9 °C Humidity: 58 % RH Atmospheric Pressure: 1008 mbar

Test Mode: Set the EUT to maximum output power and maximum gain.

6.3.2 Test Setup

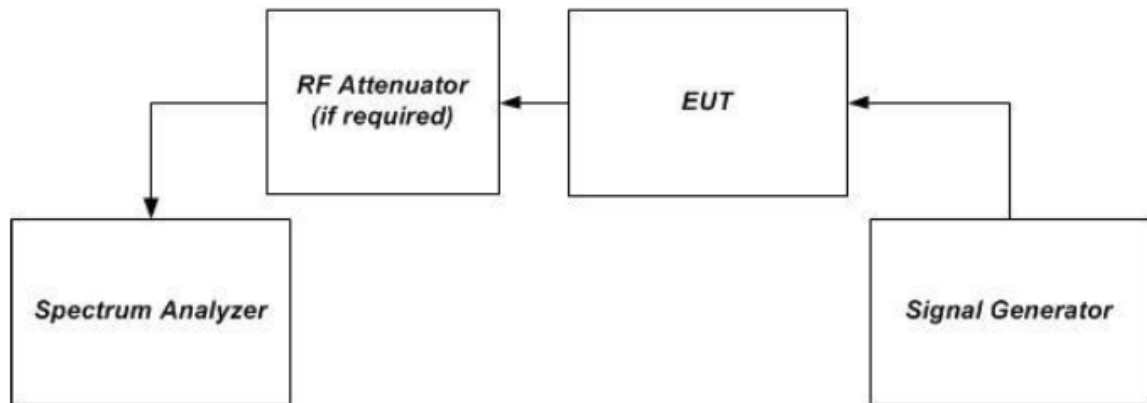

Unless otherwise agreed in writing, this document is issued by the Company subject to its General Conditions of Service printed overleaf, available on request or accessible at <https://www.sgs.com/en/Terms-and-Conditions>. Attention is drawn to the limitation of liability, indemnification and jurisdiction issues defined therein. Any holder of this document is advised that information contained hereon reflects the Company's findings at the time of its intervention only and within the limits of Client's instructions, if any. The Company's sole responsibility is to its Client and this document does not exonerate parties to a transaction from exercising all their rights and obligations under the transaction documents. This document cannot be reproduced except in full, without prior written approval of the Company. Any unauthorized alteration, forgery or falsification of the content or appearance of this document is unlawful and offenders may be prosecuted to the fullest extent of the law. Unless otherwise stated the results shown in this test report refer only to the sample(s) tested and such sample(s) are retained for 30 days only.

Attention: To check the authenticity of testing /inspection report & certificate, please contact us at telephone: (86-755) 8307 1443, or email: CN.Doccheck@sgs.com

6.3.3 Test procedure

- a) Calculate the maximum gain of the booster as follows to demonstrate compliance to the applicable gain limits as specified.
- b) For both the uplink and downlink in each supported frequency band, use each of the POUT and PIN result pairs for all signal types used in 7.2 in the following equation to obtain the maximum gain, G:
 $G \text{ (dB)} = \text{POUT(dBm)} - \text{PIN(dBm)}$.
- c) Record the maximum gain of the uplink and downlink paths for each supported frequency band, and verify that the each gain value complies with the applicable limit.
- d) Provide tabulated results in the test report.

6.3.4 Measurement Record

Please refer to Appendix - Test Data and Result for report GZCR240500044602.



Unless otherwise agreed in writing, this document is issued by the Company subject to its General Conditions of Service printed overleaf, available on request or accessible at <https://www.sgs.com/en/Terms-and-Conditions>. Attention is drawn to the limitation of liability, indemnification and jurisdiction issues defined therein. Any holder of this document is advised that information contained hereon reflects the Company's findings at the time of its intervention only and within the limits of Client's instructions, if any. The Company's sole responsibility is to its Client and this document does not exonerate parties to a transaction from exercising all their rights and obligations under the transaction documents. This document cannot be reproduced except in full, without prior written approval of the Company. Any unauthorized alteration, forgery or falsification of the content or appearance of this document is unlawful and offenders may be prosecuted to the fullest extent of the law. Unless otherwise stated the results shown in this test report refer only to the sample(s) tested and such sample(s) are retained for 30 days only.

Attention: To check the authenticity of testing /inspection report & certificate, please contact us at telephone: (86-755) 8307 1443, or email: CN.Doccheck@sgs.com

6.4 Intermodulation product

Test Requirement: 47 CFR Part 20.21(e)(8)(i)(F)

Test Method: KDB 935210 D03 clause 7.4

Limit: 20.21(e)(8)(i)(F) Intermodulation Limits:

The transmitted intermodulation products of a consumer booster at its uplink and downlink ports shall not exceed the power level of -19 dBm for the supported bands of operation.

6.4.1 E.U.T. Operation

Operating Environment:

Temperature: 24.9 °C Humidity: 58 % RH Atmospheric Pressure: 1008 mbar

Test Mode: Set the EUT to maximum output power and maximum gain.

6.4.2 Test Setup

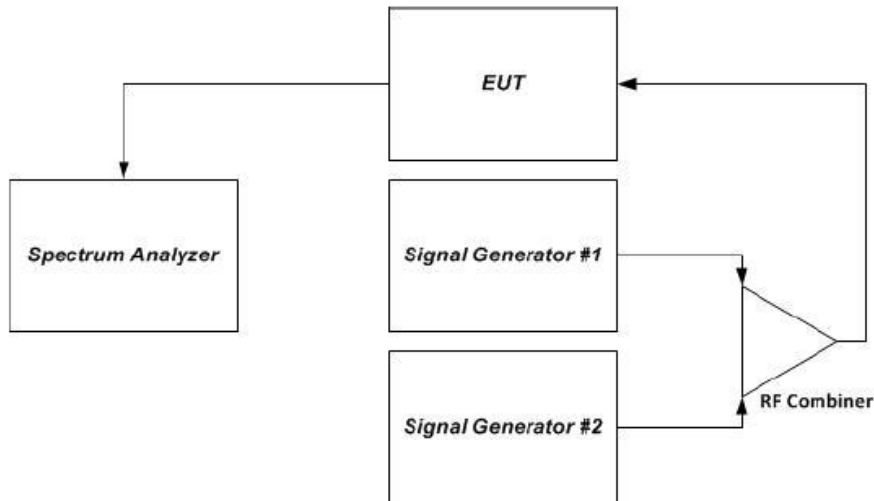

Unless otherwise agreed in writing, this document is issued by the Company subject to its General Conditions of Service printed overleaf, available on request or accessible at <https://www.sgs.com/en/Terms-and-Conditions>. Attention is drawn to the limitation of liability, indemnification and jurisdiction issues defined therein. Any holder of this document is advised that information contained hereon reflects the Company's findings at the time of its intervention only and within the limits of Client's instructions, if any. The Company's sole responsibility is to its Client and this document does not exonerate parties to a transaction from exercising all their rights and obligations under the transaction documents. This document cannot be reproduced except in full, without prior written approval of the Company. Any unauthorized alteration, forgery or falsification of the content or appearance of this document is unlawful and offenders may be prosecuted to the fullest extent of the law. Unless otherwise stated the results shown in this test report refer only to the sample(s) tested and such sample(s) are retained for 30 days only.

Attention: To check the authenticity of testing /inspection report & certificate, please contact us at telephone: (86-755) 8307 1443, or email: CN.Doccheck@sgs.com

6.4.3 Test procedure

- a) Connect the signal booster to the test equipment as shown in Test Setup. Begin with the uplink output (donor) port connected to the spectrum analyzer.
- b) Set the spectrum analyzer RBW = 3 kHz.
- c) Set the VBW $\geq 3 \times$ RBW.
- d) Select the rms detector.
- e) Set the spectrum analyzer center frequency to the center of the supported operational band under test.
- f) Set the span to 5 MHz. Affirm that the number of measurement points per sweep $\geq (2 \times \text{span})/\text{RBW}$.
- g) Configure the two signal generators for CW operation with generator #1 tuned 300 kHz below the operational band center frequency and generator #2 tuned 300 kHz above the operational band center frequency. If the maximum output power is not at the operational-band (booster pass band) center frequency, configure the test signal pair around the frequency with maximum output power as determined per 7.2.
- h) Set the signal generator amplitudes so that the power from each into the EUT is equivalent, then turn on the RF output.
- i) Simultaneously increase each signal generators' amplitude equally until just before the EUT begins AGC, then affirm that all intermodulation-product emissions (if any occur) are below the specified limit of -19 dBm.
- j) Use the trace averaging function of the spectrum analyzer, and wait for the trace to stabilize. Place a marker at the highest amplitude intermodulation-product emission.
- k) Record the maximum intermodulation product amplitude level that is observed.
- l) Capture the spectrum analyzer trace for inclusion in the test report.
- m) Repeat 7.4e) to 7.4l) for all uplink and downlink operational bands.
- n) Increase the signal generator amplitude in 2 dB steps to 10 dB above the AGC threshold determined in 7.4i), but not exceeding the maximum input level of 5.5, to affirm that the EUT maintains compliance with the intermodulation limit. The test report shall include either a statement describing that the device complies at 10 dB above AGC or at the 5.5 power levels, or a table showing compliance at the additional input power(s) required.

6.4.4 Measurement Record

Please refer to Appendix - Test Data and Result for report GZCR240500044602.



Unless otherwise agreed in writing, this document is issued by the Company subject to its General Conditions of Service printed overleaf, available on request or accessible at <https://www.sgs.com/en/Terms-and-Conditions>. Attention is drawn to the limitation of liability, indemnification and jurisdiction issues defined therein. Any holder of this document is advised that information contained hereon reflects the Company's findings at the time of its intervention only and within the limits of Client's instructions, if any. The Company's sole responsibility is to its Client and this document does not exonerate parties to a transaction from exercising all their rights and obligations under the transaction documents. This document cannot be reproduced except in full, without prior written approval of the Company. Any unauthorized alteration, forgery or falsification of the content or appearance of this document is unlawful and offenders may be prosecuted to the fullest extent of the law. Unless otherwise stated the results shown in this test report refer only to the sample(s) tested and such sample(s) are retained for 30 days only.

Attention: To check the authenticity of testing /inspection report & certificate, please contact us at telephone: (86-755) 8307 1443, or email: CN.Doccheck@sgs.com

6.5 Out-of-band emissions

Test Requirement: 47 CFR Part 20.21(e)(8)(i)(E)

Test Method: KDB 935210 D03 clause 7.5

Limit: 20.21(e)(8)(i)(E) Out of Band Emission Limits:

Booster out of band emissions (OOBE) shall be at least 6 dB below the FCC's mobile emission limits for the supported bands of operation.

27.53(c)

For operations in the 746-758 MHz band and the 776-788 MHz band, the power of any emission outside the licensee's frequency band(s) of operation shall be attenuated below the transmitter power (P) within the licensed band(s) of operation, measured in watts, in accordance with the following:

- (1) On any frequency outside the 746-758 MHz band, the power of any emission shall be attenuated outside the band below the transmitter power (P) by at least $43 + 10 \log (P)$ dB;
- (2) On any frequency outside the 776-788 MHz band, the power of any emission shall be attenuated outside the band below the transmitter power (P) by at least $43 + 10 \log (P)$ dB;
- (3) On all frequencies between 763-775 MHz and 793-805 MHz, by a factor not less than $76 + 10 \log (P)$ dB in a 6.25 kHz band segment, for base and fixed stations;
- (4) On all frequencies between 763-775 MHz and 793-805 MHz, by a factor not less than $65 + 10 \log (P)$ dB in a 6.25 kHz band segment, for mobile and portable stations;

27.53(g)

For operations in the 600 MHz band and the 698-746 MHz band, the power of any emission outside a licensee's frequency band(s) of operation shall be attenuated below the transmitter power (P) within the licensed band(s) of operation, measured in watts, by at least $43 + 10 \log (P)$ dB.

22.917

The power of any emission outside of the authorized operating frequency ranges must be attenuated below the transmitting power (P) by a factor of at least $43 + 10 \log (P)$ dB.



Unless otherwise agreed in writing, this document is issued by the Company subject to its General Conditions of Service printed overleaf, available on request or accessible at <https://www.sgs.com/en/Terms-and-Conditions>. Attention is drawn to the limitation of liability, indemnification and jurisdiction issues defined therein. Any holder of this document is advised that information contained hereon reflects the Company's findings at the time of its intervention only and within the limits of Client's instructions, if any. The Company's sole responsibility is to its Client and this document does not exonerate parties to a transaction from exercising all their rights and obligations under the transaction documents. This document cannot be reproduced except in full, without prior written approval of the Company. Any unauthorized alteration, forgery or falsification of the content or appearance of this document is unlawful and offenders may be prosecuted to the fullest extent of the law. Unless otherwise stated the results shown in this test report refer only to the sample(s) tested and such sample(s) are retained for 30 days only.

Attention: To check the authenticity of testing /inspection report & certificate, please contact us at telephone: (86-755) 8307 1443, or email: CN.Doccheck@sgs.com

6.5.1 E.U.T. Operation

Operating Environment:

Temperature: 24.9 °C Humidity: 58 % RH Atmospheric Pressure: 1008 mbar

Test Mode: Set the EUT to maximum output power and maximum gain.

6.5.2 Test Setup

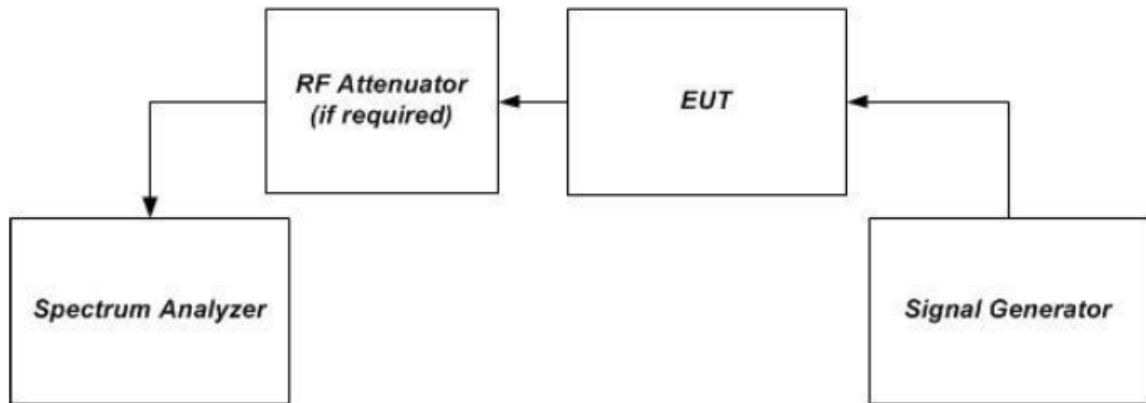

6.5.3 Test procedure

- a) Connect the EUT to the test equipment as shown in Figure 1. Begin with the uplink output (donor) port connected to the spectrum analyzer.
- b) Configure the signal generator for the appropriate operation for all uplink and downlink bands:
 - 1) GSM: 0.2 MHz from upper and lower band edges.
 - 2) LTE (5 MHz): 2.5 MHz from upper and lower band edges.
 - 3) CDMA: 1.25 MHz from upper and lower band edges, except for cellular band as follows (only the upper and lower frequencies need to be tested):
824.88 MHz, 845.73 MHz, 836.52 MHz, 848.10 MHz,
869.88 MHz, 890.73 MHz, 881.52 MHz, 893.10 MHz.

NOTE 1–Alternative test modulation types:

 - CDMA (alternative 1.25 MHz AWGN)
 - LTE 5 MHz (alternative W-CDMA or 4.1 MHz AWGN)

NOTE 2–For LTE, the signal generator should use the uplink and downlink signal types for these modulations in uplink and downlink tests, respectively. LTE shall use 5 MHz signal, 25 resource blocks transmitting.

NOTE 3–When using an AWGN test signal, the bandwidth shall be the measured 99% OBW.



Unless otherwise agreed in writing, this document is issued by the Company subject to its General Conditions of Service printed overleaf, available on request or accessible at <https://www.sgs.com/en/Terms-and-Conditions>. Attention is drawn to the limitation of liability, indemnification and jurisdiction issues defined therein. Any holder of this document is advised that information contained hereon reflects the Company's findings at the time of its intervention only and within the limits of Client's instructions, if any. The Company's sole responsibility is to its Client and this document does not exonerate parties to a transaction from exercising all their rights and obligations under the transaction documents. This document cannot be reproduced except in full, without prior written approval of the Company. Any unauthorized alteration, forgery or falsification of the content or appearance of this document is unlawful and offenders may be prosecuted to the fullest extent of the law. Unless otherwise stated the results shown in this test report refer only to the sample(s) tested and such sample(s) are retained for 30 days only.

Attention: To check the authenticity of testing /inspection report & certificate, please contact us at telephone: (86-755) 8307 1443, or email: CN.Doccheck@sgs.com

- c) Set the signal generator amplitude to the maximum power level prior to AGC similar to 7.2.2e) to 7.2.2f) of the power measurement procedures for the appropriate modulations.
- d) Set RBW = measurement bandwidth specified in the applicable rule section for the supported frequency band (see Appendix A for cross-reference to applicable rule section).
- e) Set VBW = 3 × RBW.
- f) Select the power averaging (rms) detector.
- g) Sweep time = auto-couple.
- h) Set the analyzer start frequency to the upper band/block edge frequency and the stop frequency to the upper band/block edge frequency plus: 300 kHz (when operational frequency is < 1 GHz), or 3 MHz (when operational frequency is ≥ 1 GHz).
- i) Trace average at least 100 traces in power averaging (i.e., rms) mode.
- j) Use peak marker function to find the maximum power level.
- k) Capture the spectrum analyzer trace of the power level for inclusion in the test report.
- l) Increase the signal generator amplitude in 2 dB steps until the maximum input level per 5.5 is reached. Affirm that the EUT maintains compliance with the OOB limits. The test report shall include either a statement describing that the device complies at 10 dB above AGC or at the 5.5 power levels, or a table showing compliance at the additional input power(s) required.
- m) Reset the analyzer start frequency to the lower band/block edge frequency minus: 300 kHz (when operational frequency is < 1 GHz), or 3 MHz (when operational frequency is ≥ 1 GHz), and the stop frequency to the lower band/block edge frequency, then repeat 7.5i) to 7.5l).
- n) Repeat 7.5b) through 7.5m) for each uplink and downlink operational band.

6.5.4 Measurement Record

Please refer to Appendix - Test Data and Result for report GZCR240500044602.



Unless otherwise agreed in writing, this document is issued by the Company subject to its General Conditions of Service printed overleaf, available on request or accessible at <https://www.sgs.com/en/Terms-and-Conditions>. Attention is drawn to the limitation of liability, indemnification and jurisdiction issues defined therein. Any holder of this document is advised that information contained hereon reflects the Company's findings at the time of its intervention only and within the limits of Client's instructions, if any. The Company's sole responsibility is to its Client and this document does not exonerate parties to a transaction from exercising all their rights and obligations under the transaction documents. This document cannot be reproduced except in full, without prior written approval of the Company. Any unauthorized alteration, forgery or falsification of the content or appearance of this document is unlawful and offenders may be prosecuted to the fullest extent of the law. Unless otherwise stated the results shown in this test report refer only to the sample(s) tested and such sample(s) are retained for 30 days only.

Attention: To check the authenticity of testing /inspection report & certificate, please contact us at telephone: (86-755) 8307 1443, or email: CN.Doccheck@sgs.com

6.6 Conducted spurious emissions

Test Requirement: 47 CFR Part 2.1051

Test Method: KDB 935210 D03 clause 7.5

Limit: 20.21(e)(8)(j)(E) Out of Band Emission Limits:

Booster out of band emissions (OOBE) shall be at least 6 dB below the FCC's mobile emission limits for the supported bands of operation.

Refer to clause 6.5 of this report for more details.

6.6.1 E.U.T. Operation

Operating Environment:

Temperature: 24.9 °C Humidity: 58 % RH Atmospheric Pressure: 1008 mbar

Test Mode: Set the EUT to maximum output power and maximum gain.

6.6.2 Test Setup

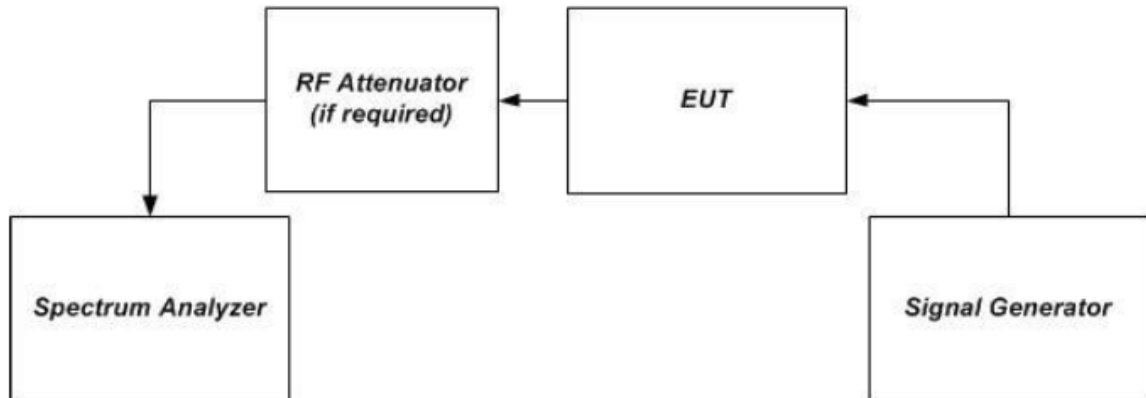

6.6.3 Test procedure

- Connect the EUT to the test equipment as shown in Test Setup. Begin with the uplink output (donor) port connected to the spectrum analyzer.
- Configure the signal generator for AWGN with a 99% OBW of 4.1 MHz, with a center frequency corresponding to the center of the CMRS band under test.
- Set the signal generator amplitude to the level determined in the power measurement procedure in 7.2.
- Turn on the signal generator RF output and measure the spurious emission power levels with an appropriate measuring instrument as follows.



Unless otherwise agreed in writing, this document is issued by the Company subject to its General Conditions of Service printed overleaf, available on request or accessible at <https://www.sgs.com/en/Terms-and-Conditions>. Attention is drawn to the limitation of liability, indemnification and jurisdiction issues defined therein. Any holder of this document is advised that information contained herein reflects the Company's findings at the time of its intervention only and within the limits of Client's instructions, if any. The Company's sole responsibility is to its Client and this document does not exonerate parties to a transaction from exercising all their rights and obligations under the transaction documents. This document cannot be reproduced except in full, without prior written approval of the Company. Any unauthorized alteration, forgery or falsification of the content or appearance of this document is unlawful and offenders may be prosecuted to the fullest extent of the law. Unless otherwise stated the results shown in this test report refer only to the sample(s) tested and such sample(s) are retained for 30 days only.

Attention: To check the authenticity of testing /inspection report & certificate, please contact us at telephone: (86-755) 8307 1443, or email: CN.Doccheck@sgs.com

- 1) Set RBW = measurement bandwidth specified in the applicable rule section for the operational frequency band under consideration (see Appendix A for relevant cross-references). Note that many of the individual rule sections permit the use of a narrower RBW [typically $\geq 1\%$ of the emission bandwidth (EBW)] to enhance measurement accuracy, but the result must then be integrated over the specified measurement bandwidth.
 - 2) Set VBW = $3 \times$ RBW.
 - 3) Select the power averaging (rms) detector. (See above note regarding the use of a peak detector for preliminary measurements.)
 - 4) Sweep time = auto-couple.
 - 5) Set the analyzer start frequency to the lowest radio frequency signal generated in the equipment, without going below 9 kHz, and the stop frequency to the lower band/block edge frequency minus 100 kHz or 1 MHz, as specified in the applicable rule part. Note that the number of measurement points in each sweep must be $\geq (2 \times \text{span}/\text{RBW})$, which may require that the measurement range defined by the preceding start and stop frequencies be subdivided, depending on the available number of measurement points of the spectrum analyzer. Trace average at least 10 traces in power averaging (i.e., rms) mode.
 - 6) Sweep time = auto-couple.
 - 7) Use the peak marker function to identify the highest amplitude level over each measured frequency range. Record the frequency and amplitude and capture a plot for inclusion in the test report.
 - 8) Reset the analyzer start frequency to the upper band/block edge frequency plus 100 kHz or 1 MHz, as specified in the applicable rule part, and the analyzer stop frequency to 10 times the highest frequency of the fundamental emission. Note that the number of measurement points in each sweep must be $\geq (2 \times \text{span}/\text{RBW})$ which may require that the measurement range defined by the start and stop frequencies above be subdivided, depending on the available number of measurement points provided by the spectrum analyzer.
 - 9) Use the peak marker function to identify the highest amplitude level over each of the measured frequency ranges. Record the frequency and amplitude and capture a plot for inclusion in the test report.
- e) Repeat 7.6b) through 7.6d) for each supported frequency band of operation.

6.6.4 Measurement Record

Please refer to Appendix - Test Data and Result for report GZCR240500044602.



Unless otherwise agreed in writing, this document is issued by the Company subject to its General Conditions of Service printed overleaf, available on request or accessible at <https://www.sgs.com/en/Terms-and-Conditions>. Attention is drawn to the limitation of liability, indemnification and jurisdiction issues defined therein. Any holder of this document is advised that information contained hereon reflects the Company's findings at the time of its intervention only and within the limits of Client's instructions, if any. The Company's sole responsibility is to its Client and this document does not exonerate parties to a transaction from exercising all their rights and obligations under the transaction documents. This document cannot be reproduced except in full, without prior written approval of the Company. Any unauthorized alteration, forgery or falsification of the content or appearance of this document is unlawful and offenders may be prosecuted to the fullest extent of the law. Unless otherwise stated the results shown in this test report refer only to the sample(s) tested and such sample(s) are retained for 30 days only.

Attention: To check the authenticity of testing /inspection report & certificate, please contact us at telephone: (86-755) 8307 1443, or email: CN.Doccheck@sgs.com

6.7 Noise limit

Test Requirement: 47 CFR Part 20.21(e)(8)(i)(A), 20.21(e)(8)(i)(H), 20.21(e)(4)

Test Method: KDB 935210 D03 clause 7.7

Limit: *20.21(e)(8)(i)(A) Noise Limit*

(1) The transmitted noise power in dBm/MHz of consumer boosters at their uplink port shall not exceed -103 dBm/MHz - RSSI. RSSI (received signal strength indication expressed in negative dB units relative to 1 mW) is the downlink composite received signal power in dBm at the booster donor port for all base stations in the band of operation.

(2) The transmitted maximum noise power in dBm/MHz of consumer boosters at their uplink and downlink ports shall not exceed the following limits:

(i) Fixed booster maximum noise power shall not exceed -102.5 dBm/MHz + 20 Log₁₀ (Frequency), where Frequency is the uplink mid-band frequency of the supported spectrum bands in MHz.

(ii) Mobile booster maximum noise power shall not exceed -59 dBm/MHz.

20.21(e)(8)(i)(H) Transmit Power Off Mode

When the consumer booster cannot otherwise meet the noise and gain limits defined herein it must operate in "Transmit Power Off Mode." In this mode of operation, the uplink and downlink noise power shall not exceed -70 dBm/MHz and both uplink and downlink gain shall not exceed the lesser of 23 dB or MSCL.

6.7.1 E.U.T. Operation

Operating Environment:

Temperature: 24.9 °C Humidity: 58 % RH Atmospheric Pressure: 1008 mbar

Test Mode: Set the EUT to maximum gain.

6.7.2 Test Setup

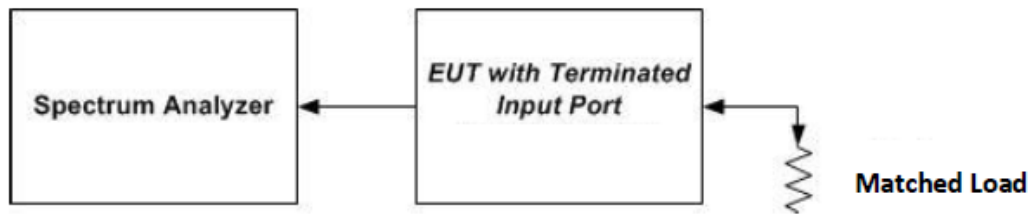

Noise limit test setup



Unless otherwise agreed in writing, this document is issued by the Company subject to its General Conditions of Service printed overleaf, available on request or accessible at <https://www.sgs.com/en/Terms-and-Conditions>. Attention is drawn to the limitation of liability, indemnification and jurisdiction issues defined therein. Any holder of this document is advised that information contained hereon reflects the Company's findings at the time of its intervention only and within the limits of Client's instructions, if any. The Company's sole responsibility is to its Client and this document does not exonerate parties to a transaction from exercising all their rights and obligations under the transaction documents. This document cannot be reproduced except in full, without prior written approval of the Company. Any unauthorized alteration, forgery or falsification of the content or appearance of this document is unlawful and offenders may be prosecuted to the fullest extent of the law. Unless otherwise stated the results shown in this test report refer only to the sample(s) tested and such sample(s) are retained for 30 days only.

Attention: To check the authenticity of testing /inspection report & certificate, please contact us at telephone: (86-755) 8307 1443, or email: CN.Doccheck@sgs.com

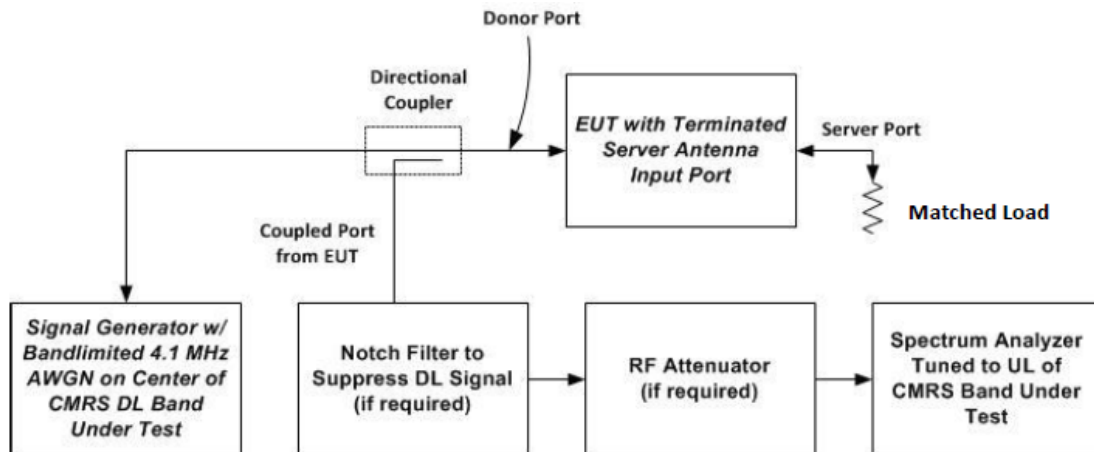

Test setup for uplink noise power measurement in the presence of a downlink signal

6.7.3 Test procedure

For maximum transmitter noise power level

- a) Connect the EUT to the test equipment as shown in Noise limit test setup. Begin with the uplink output (donor) port connected to the spectrum analyzer. When measuring downlink noise, connect the downlink output (server) port to the spectrum analyzer.
- b) Set the spectrum analyzer RBW to 1 MHz with the VBW $\geq 3 \times$ RBW.
- c) Select the power averaging (rms) detector and trace average over at least 100 traces.
- d) Set the center frequency of the spectrum analyzer to the center of the CMRS band under test with the span $\geq 2 \times$ the CMRS band.
- e) Measure the maximum transmitter noise power level.
- f) Save the spectrum analyzer plot as necessary for inclusion in the final test report.
- g) Repeat 7.7b) to 7.7f) for all operational uplink and downlink bands.
- h) Connect the EUT to the test equipment as shown in Figure 4 for uplink noise power measurement in the presence a downlink signal. Affirm the coupled path of the RF coupler is connected to the spectrum analyzer.
- i) Configure the signal generator for AWGN operation with a 99% OBW of 4.1 MHz.
- j) Set the spectrum analyzer RBW for 1 MHz, VBW $\geq 3 \times$ RBW, with a power averaging (rms) detector with at least 100 trace averages.
- k) Set the center frequency of the spectrum analyzer to the center of the CMRS band under test, with the span $\geq 2 \times$ the CMRS band. This shall include all spectrum blocks in the particular CMRS band under test (see Appendix A).
- l) For uplink noise measurements, set the spectrum analyzer center frequency for the uplink band under test, and tune the signal generator to the center of the paired downlink band.



Unless otherwise agreed in writing, this document is issued by the Company subject to its General Conditions of Service printed overleaf, available on request or accessible at <https://www.sgs.com/en/Terms-and-Conditions>. Attention is drawn to the limitation of liability, indemnification and jurisdiction issues defined therein. Any holder of this document is advised that information contained herein reflects the Company's findings at the time of its intervention only and within the limits of Client's instructions, if any. The Company's sole responsibility is to its Client and this document does not exonerate parties to a transaction from exercising all their rights and obligations under the transaction documents. This document cannot be reproduced except in full, without prior written approval of the Company. Any unauthorized alteration, forgery or falsification of the content or appearance of this document is unlawful and offenders may be prosecuted to the fullest extent of the law. Unless otherwise stated the results shown in this test report refer only to the sample(s) tested and such sample(s) are retained for 30 days only.

Attention: To check the authenticity of testing / inspection report & certificate, please contact us at telephone: (86-755) 8307 1443, or email: CN.Doccheck@sgs.com

m) Measure the maximum transmitter noise power level while varying the downlink signal generator output level from -90 dBm to -20 dBm, as measured at the input port (i.e., downlink signal level at the booster donor port node of Figure 4), in 1 dB steps inside the RSSI-dependent region, and in 10 dB steps outside the RSSI-dependent region. Report the six values closest to the limit, with at least two points within the RSSI-dependent region of the limit. See Appendix D for noise limits graphs.

n) Repeat 7.7.1h) through 7.7.1m) for all operational uplink bands.

For variable uplink noise timing

Variable uplink noise timing is to be measured as follows, using the test setup shown in Test setup for uplink noise power measurement in the presence of a downlink signal.

a) Set the spectrum analyzer to the uplink frequency to be measured.

b) Set the span to 0 Hz, with a sweep time of 10 seconds.

c) Set the power level of signal generator to the lowest level of the RSSI-dependent noise [see 7.7.1m)].

d) Select MAX HOLD and increase the power level of signal generator by 10 dB for mobile boosters, and 20 dB for fixed boosters.

e) Confirm that the uplink noise decreases to the specified level within 1 second for mobile devices, and within 3 seconds for fixed devices.18

f) Repeat 7.7.2a) to 7.7.2e) for all operational uplink bands.

g) Include plots and summary table in test report.

6.7.4 Measurement Record

Please refer to Appendix - Test Data and Result for report GZCR240500044602.



Unless otherwise agreed in writing, this document is issued by the Company subject to its General Conditions of Service printed overleaf, available on request or accessible at <https://www.sgs.com/en/Terms-and-Conditions>. Attention is drawn to the limitation of liability, indemnification and jurisdiction issues defined therein. Any holder of this document is advised that information contained hereon reflects the Company's findings at the time of its intervention only and within the limits of Client's instructions, if any. The Company's sole responsibility is to its Client and this document does not exonerate parties to a transaction from exercising all their rights and obligations under the transaction documents. This document cannot be reproduced except in full, without prior written approval of the Company. Any unauthorized alteration, forgery or falsification of the content or appearance of this document is unlawful and offenders may be prosecuted to the fullest extent of the law. Unless otherwise stated the results shown in this test report refer only to the sample(s) tested and such sample(s) are retained for 30 days only.

Attention: To check the authenticity of testing /inspection report & certificate, please contact us at telephone: (86-755) 8307 1443, or email: CN.Doccheck@sgs.com

6.8 Uplink inactivity

Test Requirement: 47 CFR Part 20.21(e)(8)(i)(I)
 Test Method: KDB 935210 D03 clause 7.8
 Limit: 20.21(e)(8)(i)(I) Uplink Inactivity
 When a consumer booster is not serving an active device connection after 5 minutes the uplink noise power shall not exceed -70 dBm/MHz.

6.8.1 E.U.T. Operation

Operating Environment:
 Temperature: 24.9 °C Humidity: 58 % RH Atmospheric Pressure: 1008 mbar
 Test Mode: Set the EUT to maximum gain.

6.8.2 Test Setup

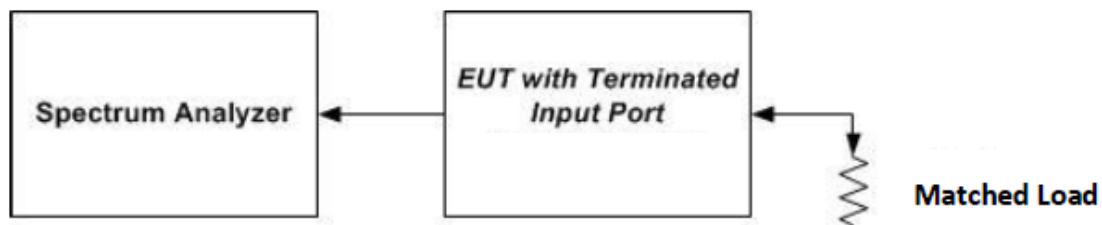

6.8.3 Test procedure

- For maximum transmitter noise power level
- Connect the EUT to the test equipment as shown in Figure 3 with the uplink output (donor) port connected to the spectrum analyzer.
 - Select the power averaging (rms) detector.
 - Set the spectrum analyzer RBW for 1 MHz with the VBW $\geq 3 \square$ RBW.
 - Set the center frequency of the spectrum analyzer to the center of the uplink operational band.
 - Set the span for 0 Hz with a single sweep time for a minimum of 330 seconds.
 - Start to capture a new trace using MAX HOLD.
 - After approximately 15 seconds, turn on the EUT power.
 - After the full spectrum analyzer trace is complete, place a MARKER on the leading edge of the pulse, then use the DELTA MARKER METHOD to measure the time until the uplink becomes inactive.
 - Affirm that the noise level is below the uplink inactivity noise power limit, as specified by the rules.
 - Capture the plot for inclusion in the test report.
 - Measure noise using procedures in 7.7.1a) to 7.7.1f).
 - Repeat 7.8d) through 7.8k) for all operational uplink bands.

6.8.4 Measurement Record

Please refer to Appendix - Test Data and Result for report GZCR240500044602.



Unless otherwise agreed in writing, this document is issued by the Company subject to its General Conditions of Service printed overleaf, available on request or accessible at <https://www.sgs.com/en/Terms-and-Conditions>. Attention is drawn to the limitation of liability, indemnification and jurisdiction issues defined therein. Any holder of this document is advised that information contained hereon reflects the Company's findings at the time of its intervention only and within the limits of Client's instructions, if any. The Company's sole responsibility is to its Client and this document does not exonerate parties to a transaction from exercising all their rights and obligations under the transaction documents. This document cannot be reproduced except in full, without prior written approval of the Company. Any unauthorized alteration, forgery or falsification of the content or appearance of this document is unlawful and offenders may be prosecuted to the fullest extent of the law. Unless otherwise stated the results shown in this test report refer only to the sample(s) tested and such sample(s) are retained for 30 days only.

Attention: To check the authenticity of testing / inspection report & certificate, please contact us at telephone: (86-755) 8307 1443, or email: CN.Doccheck@sgs.com

6.9 Variable booster gain

Test Requirement: 47 CFR Part 20.21(e)(8)(i)(C)(1), 20.21(e)(8)(i)(H), 20.21(e)(4)

Test Method: KDB 935210 D03 clause 7.9

Limit: 20.21(e)(8)(i)(C)(1)

The uplink gain in dB of a consumer booster referenced to its input and output ports shall not exceed $-34 \text{ dB} - \text{RSSI} + \text{MSCL}$.

20.21(e)(8)(i)(H) Transmit Power Off Mode

When the consumer booster cannot otherwise meet the noise and gain limits defined herein it must operate in "Transmit Power Off Mode." In this mode of operation, the uplink and downlink noise power shall not exceed -70 dBm/MHz and both uplink and downlink gain shall not exceed the lesser of 23 dB or MSCL.

6.9.1 E.U.T. Operation

Operating Environment:

Temperature: 24.9 °C Humidity: 58 % RH Atmospheric Pressure: 1008 mbar

Test Mode: Set the EUT to maximum gain.

6.9.2 Test Setup

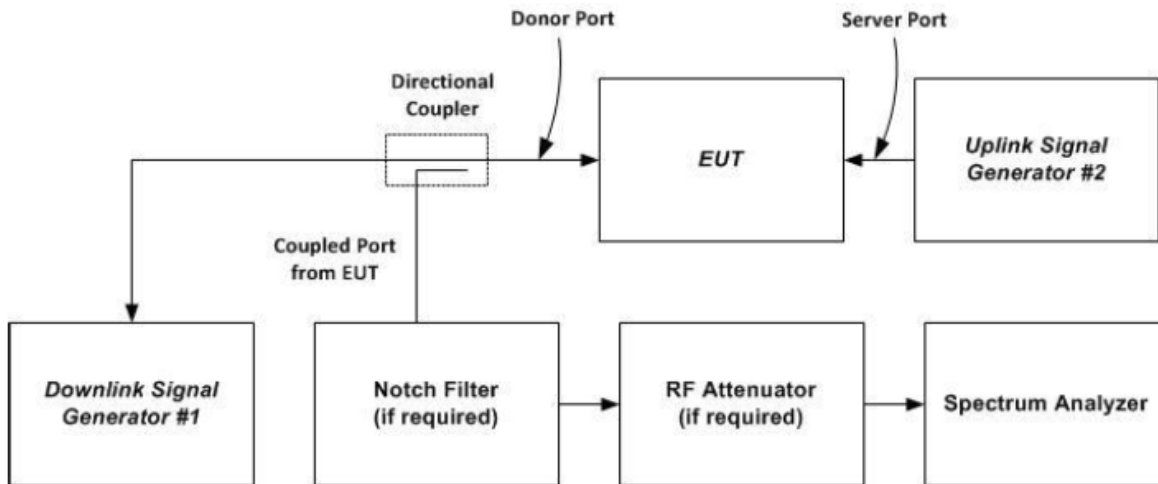

Unless otherwise agreed in writing, this document is issued by the Company subject to its General Conditions of Service printed overleaf, available on request or accessible at <https://www.sgs.com/en/Terms-and-Conditions>. Attention is drawn to the limitation of liability, indemnification and jurisdiction issues defined therein. Any holder of this document is advised that information contained hereon reflects the Company's findings at the time of its intervention only and within the limits of Client's instructions, if any. The Company's sole responsibility is to its Client and this document does not exonerate parties to a transaction from exercising all their rights and obligations under the transaction documents. This document cannot be reproduced except in full, without prior written approval of the Company. Any unauthorized alteration, forgery or falsification of the content or appearance of this document is unlawful and offenders may be prosecuted to the fullest extent of the law. Unless otherwise stated the results shown in this test report refer only to the sample(s) tested and such sample(s) are retained for 30 days only.

Attention: To check the authenticity of testing /inspection report & certificate, please contact us at telephone: (86-755) 8307 1443, or email: CN.Doccheck@sgs.com

6.9.3 Test procedure

For variable gain

- a) Connect the EUT to the test equipment as shown in Test Setup with the uplink output (donor) port connected to signal generator #1. Affirm that the coupled path of the RF coupler is connected to the spectrum analyzer.
- b) Configure downlink signal generator #1 for AWGN operation with a 99% OBW of 4.1 MHz, tuned to the center of the operational band.
- c) Set the power level and frequency of signal generator #2 to a value that is 5 dB below the AGC level determined from 7.2. The signal type is AWGN with a 99% OBW of 4.1 MHz.
- d) Set RBW = 100 kHz.
- e) Set VBW ≥ 300 kHz.
- f) Select the CHANNEL POWER measurement mode.
- g) Select the power averaging (rms) detector.
- h) Affirm that the number of measurement points per sweep $\geq (2 \times \text{span})/\text{RBW}$.
- i) Sweep time = auto couple or as necessary (but no less than auto couple value).
- j) Trace average at least 10 traces in power averaging (i.e., rms) mode.
- k) Measure the maximum channel power and compute maximum gain when varying the signal generator #1 output to a level from -90 dBm to -20 dBm, as measured at the input port (i.e., downlink signal level at the booster donor port node of Figure 5), in 1 dB steps inside the RSSI-dependent region, and 10 dB steps outside the RSSI-dependent region. Report the six values closest to the limit, including at least two points from within the RSSI-dependent region of operation. See gain limit in charts in Appendix D for uplink gain requirements. Additionally, document that the EUT provides equivalent uplink and downlink gain, and when operating in shutoff mode that the uplink and downlink gain is within the transmit power off mode gain limits.
- l) Repeat 7.9.1b) to 7.9.1k) for all operational uplink bands.

For variable uplink gain timing

Variable uplink gain timing is to be measured as follows, using the test setup shown in Test Setup.

- a) Set the spectrum analyzer to the uplink frequency to be measured.
- b) Set the span to 0 Hz with a sweep time of 10 seconds.
- c) Set the power level of signal generator #1 to the lowest level of the RSSI-dependent gain [see 7.9.1k)].
- d) Select MAX HOLD and increase the power level of signal generator #1 by 10 dB for mobile boosters, and by 20 dB for fixed indoor boosters. Signal generator #2 remains same, as described in 7.9.1c).
- e) Confirm that the uplink gain decreases to the specified levels, within 1 second for mobile devices, and within 3 seconds for fixed devices.
- f) Repeat 7.9.2a) to 7.9.2e) for all operational uplink bands.

6.9.4 Measurement Record

Please refer to Appendix - Test Data and Result for report GZCR240500044602.



Unless otherwise agreed in writing, this document is issued by the Company subject to its General Conditions of Service printed overleaf, available on request or accessible at <https://www.sgs.com/en/Terms-and-Conditions>. Attention is drawn to the limitation of liability, indemnification and jurisdiction issues defined therein. Any holder of this document is advised that information contained hereon reflects the Company's findings at the time of its intervention only and within the limits of Client's instructions, if any. The Company's sole responsibility is to its Client and this document does not exonerate parties to a transaction from exercising all their rights and obligations under the transaction documents. This document cannot be reproduced except in full, without prior written approval of the Company. Any unauthorized alteration, forgery or falsification of the content or appearance of this document is unlawful and offenders may be prosecuted to the fullest extent of the law. Unless otherwise stated the results shown in this test report refer only to the sample(s) tested and such sample(s) are retained for 30 days only.

Attention: To check the authenticity of testing /inspection report & certificate, please contact us at telephone: (86-755) 8307 1443, or email: CN.Doccheck@sgs.com

6.10 Occupied bandwidth

Test Requirement: 47 CFR Part 2.1049
 Test Method: KDB 935210 D03 clause 7.10
 Limit: Compare the consistency of the output signal relative to the input signal, and to satisfy the requirements of Section 2.1049.

6.10.1 E.U.T. Operation

Operating Environment:
 Temperature: 24.9 °C Humidity: 58 % RH Atmospheric Pressure: 1008 mbar
 Test Mode: Set the EUT to maximum output power and maximum gain.

6.10.2 Test Setup

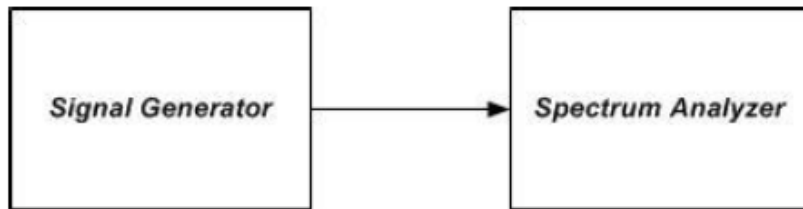

Test setup for measuring characteristics of test signals used for subsequent EUT occupied bandwidth testing

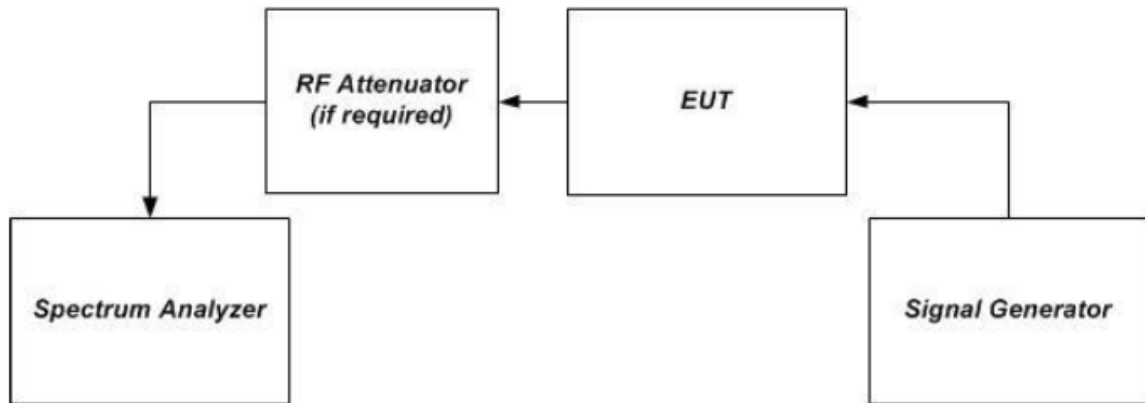

Test setup for output signal



Unless otherwise agreed in writing, this document is issued by the Company subject to its General Conditions of Service printed overleaf, available on request or accessible at <https://www.sgs.com/en/Terms-and-Conditions>. Attention is drawn to the limitation of liability, indemnification and jurisdiction issues defined therein. Any holder of this document is advised that information contained hereon reflects the Company's findings at the time of its intervention only and within the limits of Client's instructions, if any. The Company's sole responsibility is to its Client and this document does not exonerate parties to a transaction from exercising all their rights and obligations under the transaction documents. This document cannot be reproduced except in full, without prior written approval of the Company. Any unauthorized alteration, forgery or falsification of the content or appearance of this document is unlawful and offenders may be prosecuted to the fullest extent of the law. Unless otherwise stated the results shown in this test report refer only to the sample(s) tested and such sample(s) are retained for 30 days only.

Attention: To check the authenticity of testing / inspection report & certificate, please contact us at telephone: (86-755) 8307 1443, or email: CN.Doccheck@sgs.com

6.10.3 Test procedure

- a) Connect the test equipment as shown in Test setup for measuring characteristics of test signals used for subsequent EUT occupied bandwidth testing to firstly measure the characteristics of the test signals produced by the signal generator.
- b) Set VBW $\geq 3 \times$ RBW.
- c) Set the center frequency of the spectrum analyzer to the center of the operational band. The span will be adjusted for each modulation type and OBW as necessary for accurately viewing the signals.
- d) Set the signal generator for power level to match the values obtained from the tests of 7.2.
- e) Set the signal generator modulation type for GSM with a PRBS pattern and allow the trace on the signal generator to stabilize adjusting the span as necessary.
- f) Set the spectrum analyzer RBW for 1% to 5% of the EBW.
- g) Capture the spectrum analyzer trace for inclusion in the test report.
- h) Repeat 7.10c) to 7.10g) for CDMA and W-CDMA modulation, adjusting the span as necessary. AWGN or LTE may be used in place of W-CDMA, as an option.
- i) Repeat 7.10c) to 7.10h) for all uplink and downlink operational bands.
- j) Connect the test equipment as shown in Test setup for output signal, with the uplink output (donor) port connected to the spectrum analyzer, and the server port connected to the signal generator.
- k) Repeat 7.10c) to 7.10i) with this EUT uplink path test setup.
- l) Connect the test equipment as shown in Test setup for output signal, with the downlink output (server) port connected to the spectrum analyzer, and the donor port connected to the signal generator.
- m) Repeat 7.10c) to 7.10i) with this EUT downlink path test setup.

6.10.4 Measurement Record

Please refer to Appendix - Test Data and Result for report GZCR240500044602.



Unless otherwise agreed in writing, this document is issued by the Company subject to its General Conditions of Service printed overleaf, available on request or accessible at <https://www.sgs.com/en/Terms-and-Conditions>. Attention is drawn to the limitation of liability, indemnification and jurisdiction issues defined therein. Any holder of this document is advised that information contained hereon reflects the Company's findings at the time of its intervention only and within the limits of Client's instructions, if any. The Company's sole responsibility is to its Client and this document does not exonerate parties to a transaction from exercising all their rights and obligations under the transaction documents. This document cannot be reproduced except in full, without prior written approval of the Company. Any unauthorized alteration, forgery or falsification of the content or appearance of this document is unlawful and offenders may be prosecuted to the fullest extent of the law. Unless otherwise stated the results shown in this test report refer only to the sample(s) tested and such sample(s) are retained for 30 days only.

Attention: To check the authenticity of testing /inspection report & certificate, please contact us at telephone: (86-755) 8307 1443, or email: CN.Doccheck@sgs.com

6.11 Oscillation detection

Test Requirement: 47 CFR Part 20.21(e)(8)(ii)(A), 20.21(e)(8)(i)(H), 20.21(e)(5)

Test Method: KDB 935210 D03 clause 7.11

Limit: *20.21(e)(8)(ii)(A) Anti-Oscillation*

Consumer boosters must be able to detect and mitigate (i.e., by automatic gain reduction or shut down), any oscillations in uplink and downlink bands.

Oscillation detection and mitigation must occur automatically within 0.3 seconds in the uplink band and within 1 second in the downlink band. In cases where oscillation is detected, the booster must continue mitigation for at least one minute before restarting. After five such restarts, the booster must not resume operation until manually reset.

20.21(e)(5)

Consumer Signal Boosters must be able to detect and mitigate any unintended oscillations in uplink and downlink bands (such as may result from insufficient isolation between the antennas).

6.11.1 E.U.T. Operation

Operating Environment:

Temperature: 24.9 °C Humidity: 58 % RH Atmospheric Pressure: 1008 mbar

Test Mode: Set the EUT to maximum output power and maximum gain.



Unless otherwise agreed in writing, this document is issued by the Company subject to its General Conditions of Service printed overleaf, available on request or accessible at <https://www.sgs.com/en/Terms-and-Conditions>. Attention is drawn to the limitation of liability, indemnification and jurisdiction issues defined therein. Any holder of this document is advised that information contained hereon reflects the Company's findings at the time of its intervention only and within the limits of Client's instructions, if any. The Company's sole responsibility is to its Client and this document does not exonerate parties to a transaction from exercising all their rights and obligations under the transaction documents. This document cannot be reproduced except in full, without prior written approval of the Company. Any unauthorized alteration, forgery or falsification of the content or appearance of this document is unlawful and offenders may be prosecuted to the fullest extent of the law. Unless otherwise stated the results shown in this test report refer only to the sample(s) tested and such sample(s) are retained for 30 days only.

Attention: To check the authenticity of testing /inspection report & certificate, please contact us at telephone: (86-755) 8307 1443, or email: CN.Doccheck@sgs.com

6.11.2 Test Setup

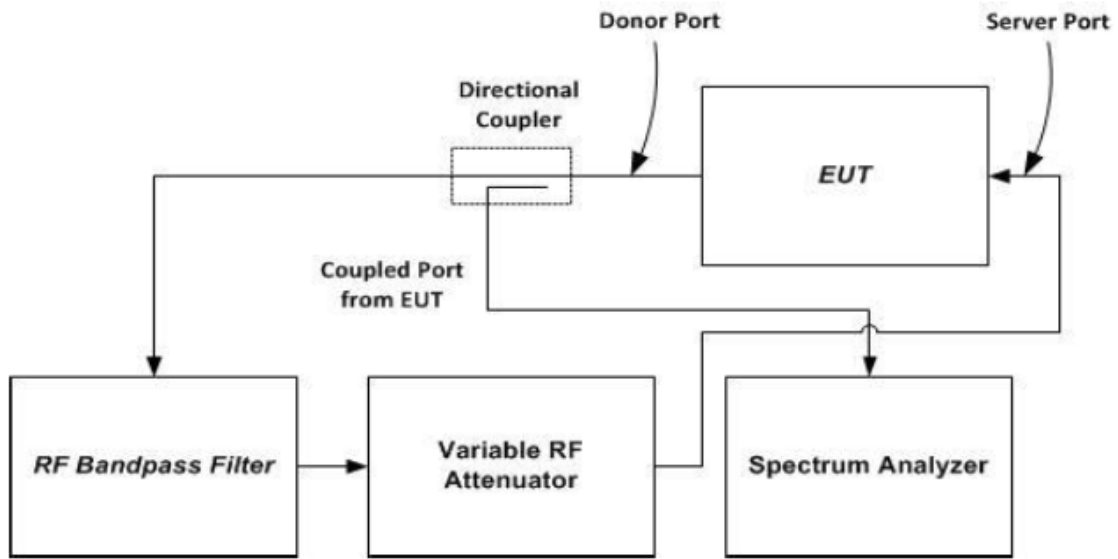

Oscillation detection test setup

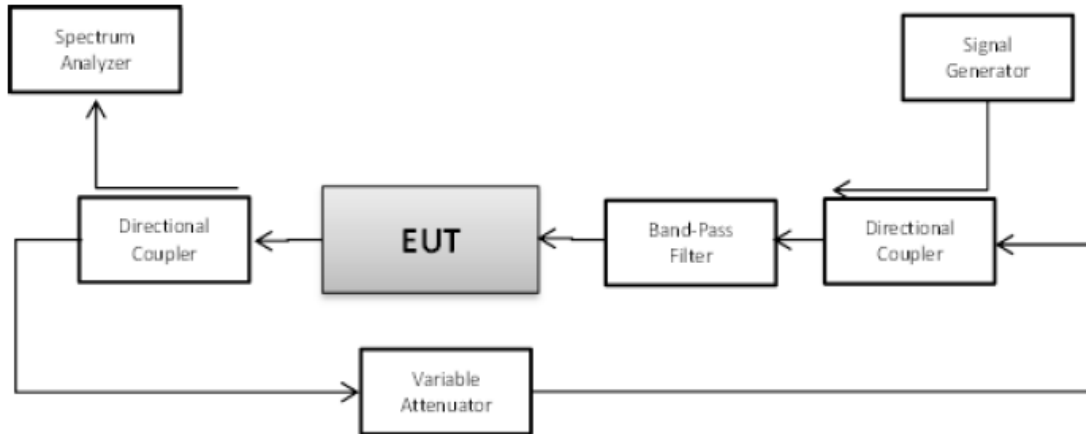

Oscillation mitigation/shutdown test setup



Unless otherwise agreed in writing, this document is issued by the Company subject to its General Conditions of Service printed overleaf, available on request or accessible at <https://www.sgs.com/en/Terms-and-Conditions>. Attention is drawn to the limitation of liability, indemnification and jurisdiction issues defined therein. Any holder of this document is advised that information contained hereon reflects the Company's findings at the time of its intervention only and within the limits of Client's instructions, if any. The Company's sole responsibility is to its Client and this document does not exonerate parties to a transaction from exercising all their rights and obligations under the transaction documents. This document cannot be reproduced except in full, without prior written approval of the Company. Any unauthorized alteration, forgery or falsification of the content or appearance of this document is unlawful and offenders may be prosecuted to the fullest extent of the law. Unless otherwise stated the results shown in this test report refer only to the sample(s) tested and such sample(s) are retained for 30 days only.

6.11.3 Test procedure

For oscillation restart tests

- a) Connect the normal-operating mode EUT to the test equipment as shown in Figure 7 beginning with the spectrum analyzer on the uplink output (donor) port. Confirm that the RF coupled path is connected to the spectrum analyzer.
- b) Spectrum analyzer settings:
 - 1) Center frequency at the center of the band under test
 - 2) Span equal or slightly exceeding the width of the band under test
 - 3) Continuous sweep, max-hold
 - 4) $RBW \geq 1 \text{ MHz}$, $VBW > 3 \times RBW$
- c) Decrease the variable attenuator until the spectrum analyzer displays a signal within the band under test. Using a marker, identify the approximate center frequency of this signal on the max-hold display, increase the attenuation by 10 dB, then reset the EUT (e.g., cycle ac/dc power).
- d) Repeat 7.11.2c) twice to ensure that the center of the signal created by the booster remains within 250 kHz of the spectrum analyzer display center frequency. If the frequency of the signal is unstable, confirm that the spectrum analyzer display is centered between the frequency extremes observed. If the signal is wider than 1 MHz, ensure that the spectrum analyzer display is centered on the signal by increasing the RBW. Reset the EUT (e.g., cycle ac/dc power) after each oscillation event, if necessary. Set the spectrum analyzer sweep trigger level to just below the peak amplitude of the displayed EUT oscillation signal.
- e) Set the spectrum analyzer to zero-span, with a sweep time of 5 seconds, and single-sweep with max-hold. The spectrum analyzer sweep trigger level in this and the subsequent steps shall be the level identified in 7.11.2d).
- f) Decrease the variable attenuator until the spectrum analyzer sweep is triggered, increase the attenuation by 10 dB, then reset the EUT (e.g., cycle ac/dc power).
- g) Reset the zero-span trigger of the spectrum analyzer, then repeat 7.11.2f) twice to ensure that the spectrum analyzer is reliably triggered, resetting the EUT (e.g., cycle ac/dc power) after each oscillation event if necessary.
- h) Reset the zero-span sweep trigger of the spectrum analyzer, and reset the EUT (e.g., cycle ac/dc power).
- i) Force the EUT into oscillation by reducing the attenuation.
- j) Use the marker function of the spectrum analyzer to measure the time from the onset of oscillation until the EUT turns off, by setting Marker 1 on the leading edge of the oscillation signal and Marker 2 on the trailing edge. The spectrum analyzer sweep time may be adjusted to improve the time resolution of these cursors.
- k) Capture the spectrum analyzer zero-span trace for inclusion in the test report. Report the power level associated with the oscillation separately if it can't be displayed on the trace.
- l) Repeat 7.11.2b) to 7.11.2k) for all operational uplink and downlink bands.



Unless otherwise agreed in writing, this document is issued by the Company subject to its General Conditions of Service printed overleaf, available on request or accessible at <https://www.sgs.com/en/Terms-and-Conditions>. Attention is drawn to the limitation of liability, indemnification and jurisdiction issues defined therein. Any holder of this document is advised that information contained hereon reflects the Company's findings at the time of its intervention only and within the limits of Client's instructions, if any. The Company's sole responsibility is to its Client and this document does not exonerate parties to a transaction from exercising all their rights and obligations under the transaction documents. This document cannot be reproduced except in full, without prior written approval of the Company. Any unauthorized alteration, forgery or falsification of the content or appearance of this document is unlawful and offenders may be prosecuted to the fullest extent of the law. Unless otherwise stated the results shown in this test report refer only to the sample(s) tested and such sample(s) are retained for 30 days only.

Attention: To check the authenticity of testing /inspection report & certificate, please contact us at telephone: (86-755) 8307 1443, or email: CN.Doccheck@sgs.com

- m) Set the spectrum analyzer zero-span sweep time for longer than 60 seconds, then measure the restart time for each operational uplink and downlink band.
- n) Replace the normal-operating mode EUT with the EUT that supports an anti-oscillation test mode.
- o) Set the spectrum analyzer zero-span time for a minimum of 120 seconds, and a single sweep.
- p) Manually trigger the spectrum analyzer zero-span sweep, and manually force the booster into oscillation as described in 7.11.2i).
- q) When the sweep is complete, place cursors between the first two oscillation detections, and save the plot for inclusion in the test report. The time between restarts must match the manufacturer's timing for the test mode, and there shall be no more than 5 restarts.
- r) Repeat 7.11.2m) to 7.11.2q) for all operational uplink and downlink bands.

For oscillation mitigation or shutdown

- a) Connect the normal-operating mode EUT to the test equipment as shown in Figure 8.
- b) Set the spectrum analyzer center frequency to the center of band under test, and use the following settings:
 - 1) RBW=30 kHz, VBW $\geq 3 \times$ RBW,
 - 2) power averaging (rms) detector,
 - 3) trace averages ≥ 100 ,
 - 4) span $\geq 120\%$ of operational band under test,
 - 5) number of sweep points $\geq 2 \times$ Span/RBW.

c) Configure the signal generator for AWGN operation with a 99% OBW of 4.1 MHz, tuned to the frequency of 2.5 MHz above the lower edge or below the upper edge of the operating band under test. Adjust the RF output level of the signal generator such that the measured power level of the AWGN signal at the output port of the booster is 30 dB less than the maximum power of the booster for the band under test. Affirm that the input signal is not obstructing the measurement of the strongest oscillation peak in the band, and is not included within the span in the measurement.

- 1) Boosters with operating spectrum passbands of 10 MHz or less may use a CW signal source at the band edge rather than AWGN.
- 2) For device passbands greater than 10 MHz, standard CMRS signal sources (i.e., CDMA, W-CDMA, LTE) may be used instead of AWGN at the band edge.
- d) Set the variable attenuator to a high attenuation setting such that the booster will operate at maximum gain when powered on. Reset the EUT (e.g., cycle ac/dc power). Allow the EUT to complete its boot-up process, to reach full operational gain, and to stabilize its operation.
- e) Set the variable attenuator such that the insertion loss for the center of the band under test (isolation) between the booster donor port and server port is 5 dB greater than the maximum gain, as recorded in the maximum gain test procedure (see 7.3), for the band under test.
- f) Verify the EUT shuts down, i.e., to mitigate the oscillations. If the booster does not shut down, measure and verify the peak oscillation level as follows.



Unless otherwise agreed in writing, this document is issued by the Company subject to its General Conditions of Service printed overleaf, available on request or accessible at <https://www.sgs.com/en/Terms-and-Conditions>. Attention is drawn to the limitation of liability, indemnification and jurisdiction issues defined therein. Any holder of this document is advised that information contained hereon reflects the Company's findings at the time of its intervention only and within the limits of Client's instructions, if any. The Company's sole responsibility is to its Client and this document does not exonerate parties to a transaction from exercising all their rights and obligations under the transaction documents. This document cannot be reproduced except in full, without prior written approval of the Company. Any unauthorized alteration, forgery or falsification of the content or appearance of this document is unlawful and offenders may be prosecuted to the fullest extent of the law. Unless otherwise stated the results shown in this test report refer only to the sample(s) tested and such sample(s) are retained for 30 days only.

Attention: To check the authenticity of testing /inspection report & certificate, please contact us at telephone: (86-755) 8307 1443, or email: CN.Doccheck@sgs.com

- 1) Allow the spectrum analyzer trace to stabilize.
- 2) Place the marker at the highest oscillation level occurring within the span, and record its output level and frequency.
- 3) Set the spectrum analyzer center frequency to the frequency with the highest oscillation signal level, and reduce the span such that the upper and lower adjacent oscillation peaks are within the span.
- 4) Use the Minimum Search Marker function to find the lowest output level that is within the span, and within the operational band under test, and record its output level and frequency.
- 5) Affirm that the peak oscillation level measured in 7.11.3f2), does not exceed by 12.0 dB the minimal output level measured in 7.11.3f4). Record the measurement results of 7.11.3f2) and 7.11.3f4) in tabular format for inclusion in the test report.
- 6) The procedure of 7.11.3f1) to 7.11.3f5) allows the spectrum analyzer trace to stabilize, and verification of shutdown or oscillation level measurement must occur within 300 seconds.20
- g) Decrease the variable attenuator in 1 dB steps, and repeat step 7.11.3f) for each 1 dB step. Continue testing to the level when the insertion loss for the center of band under test (isolation) between the booster donor port and server port is 5 dB lower than the maximum gain (see 7.3).
- h) Repeat 7.11.3a) to 7.11.3g) for all operational uplink and downlink bands.

6.11.4 Measurement Record

Please refer to Appendix - Test Data and Result for report GZCR240500044602.



Unless otherwise agreed in writing, this document is issued by the Company subject to its General Conditions of Service printed overleaf, available on request or accessible at <https://www.sgs.com/en/Terms-and-Conditions>. Attention is drawn to the limitation of liability, indemnification and jurisdiction issues defined therein. Any holder of this document is advised that information contained hereon reflects the Company's findings at the time of its intervention only and within the limits of Client's instructions, if any. The Company's sole responsibility is to its Client and this document does not exonerate parties to a transaction from exercising all their rights and obligations under the transaction documents. This document cannot be reproduced except in full, without prior written approval of the Company. Any unauthorized alteration, forgery or falsification of the content or appearance of this document is unlawful and offenders may be prosecuted to the fullest extent of the law. Unless otherwise stated the results shown in this test report refer only to the sample(s) tested and such sample(s) are retained for 30 days only.

Attention: To check the authenticity of testing /inspection report & certificate, please contact us at telephone: (86-755) 8307 1443, or email: CN.Doccheck@sgs.com

6.12 Radiated spurious emissions

Test Requirement: 47 CFR Part 2.1053, 47 CFR Part 20.21(e)(8)(i)(E)
 Test Method: KDB 935210 D03 clause 7.12
 ANSI C63.26-2015 clause 5.5
 Limit: *20.21(e)(8)(i)(E) Out of Band Emission Limits:*
 Booster out of band emissions (OOBE) shall be at least 6 dB below the FCC's mobile emission limits for the supported bands of operation.
 Refer to clause 6.5 of this report for more details.

6.12.1 E.U.T. Operation

Operating Environment:
 Temperature: 24.2 °C Humidity: 60 % RH Atmospheric Pressure: 1010 mbar
 Test Mode: Set the EUT to maximum output power and maximum gain.

6.12.2 Test Setup

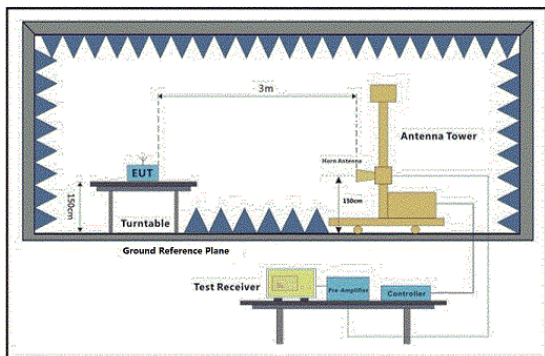

Above 1GHz

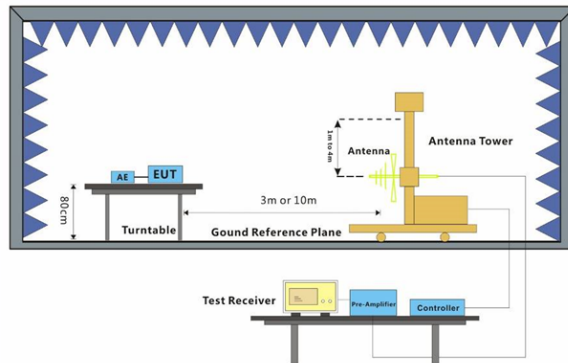

30MHz to 1GHz



Unless otherwise agreed in writing, this document is issued by the Company subject to its General Conditions of Service printed overleaf, available on request or accessible at <https://www.sgs.com/en/Terms-and-Conditions>. Attention is drawn to the limitation of liability, indemnification and jurisdiction issues defined therein. Any holder of this document is advised that information contained hereon reflects the Company's findings at the time of its intervention only and within the limits of Client's instructions, if any. The Company's sole responsibility is to its Client and this document does not exonerate parties to a transaction from exercising all their rights and obligations under the transaction documents. This document cannot be reproduced except in full, without prior written approval of the Company. Any unauthorized alteration, forgery or falsification of the content or appearance of this document is unlawful and offenders may be prosecuted to the fullest extent of the law. Unless otherwise stated the results shown in this test report refer only to the sample(s) tested and such sample(s) are retained for 30 days only.

Attention: To check the authenticity of testing /inspection report & certificate, please contact us at telephone: (86-755) 8307 1443, or email: CN.Doccheck@sgs.com

6.12.3 Test procedure

1. Scan from 30MHz to 12.75GHz, find the maximum radiation frequency to measure.
2. The technique used to find the Spurious Emissions of the transmitter was the antenna substitution method. Substitution method was performed to determine the actual ERP/EIRP emission levels of the EUT.

Below 1GHz test procedure as below:

- 1) The EUT was powered on and placed on a table in the chamber. The antenna of the transmitter was extended to its maximum length. modulation mode and the measuring receiver shall be tuned to the frequency of the transmitter under test.
- 2) Rotating through 360° the turntable. After the fundamental emission was maximized, a field strength measurement was made.
- 3) Steps 1) and 2) were performed with the EUT and the receive antenna in both vertical and horizontal polarization.
- 4) The transmitter was then removed and replaced with another antenna. The center of the antenna was approximately at the same location as the center of the transmitter.
- 5) A signal at the disturbance was fed to the substitution antenna by means of a non-radiating cable. With both the substitution and the receive antennas horizontally polarized, the receive antenna was raised and lowered to obtain a maximum reading at the test receiver. The level of the signal generator was adjusted until the measured field strength level in step 2) is obtained for this set of conditions.
- 6) The output power into the substitution antenna was then measured.
- 7) Steps 5) and 6)were repeated with both antennas vertically polarized.
- 8) Calculate power in dBm by the following formula:

Level (dBm) = Read Level (dBm) + Correction Factor (dB)

6.12.4 Measurement Record

Please refer to Appendix - Test Data and Result for report GZCR240500044602.



Unless otherwise agreed in writing, this document is issued by the Company subject to its General Conditions of Service printed overleaf, available on request or accessible at <https://www.sgs.com/en/Terms-and-Conditions>. Attention is drawn to the limitation of liability, indemnification and jurisdiction issues defined therein. Any holder of this document is advised that information contained hereon reflects the Company's findings at the time of its intervention only and within the limits of Client's instructions, if any. The Company's sole responsibility is to its Client and this document does not exonerate parties to a transaction from exercising all their rights and obligations under the transaction documents. This document cannot be reproduced except in full, without prior written approval of the Company. Any unauthorized alteration, forgery or falsification of the content or appearance of this document is unlawful and offenders may be prosecuted to the fullest extent of the law. Unless otherwise stated the results shown in this test report refer only to the sample(s) tested and such sample(s) are retained for 30 days only.

Attention: To check the authenticity of testing /inspection report & certificate, please contact us at telephone: (86-755) 8307 1443, or email: CN.Doccheck@sgs.com

7 Test Setup Photographs

Refer to Appendix - Test Setup Photos for GZCR2405000446AT

8 EUT Constructional Details (EUT Photos)

Refer to Appendix - External and Internal Photos for GZCR2405000446AT

--Report End--



Unless otherwise agreed in writing, this document is issued by the Company subject to its General Conditions of Service printed overleaf, available on request or accessible at <https://www.sgs.com/en/Terms-and-Conditions>. Attention is drawn to the limitation of liability, indemnification and jurisdiction issues defined therein. Any holder of this document is advised that information contained hereon reflects the Company's findings at the time of its intervention only and within the limits of Client's instructions, if any. The Company's sole responsibility is to its Client and this document does not exonerate parties to a transaction from exercising all their rights and obligations under the transaction documents. This document cannot be reproduced except in full, without prior written approval of the Company. Any unauthorized alteration, forgery or falsification of the content or appearance of this document is unlawful and offenders may be prosecuted to the fullest extent of the law. Unless otherwise stated the results shown in this test report refer only to the sample(s) tested and such sample(s) are retained for 30 days only.

Attention: To check the authenticity of testing /inspection report & certificate, please contact us at telephone: (86-755) 8307 1443, or email: CN.Doccheck@sgs.com