

EMISSIONS TEST REPORT FOR A LOW POWER TRANSMITTER

I. GENERAL INFORMATION

Requirement: FCC
Test Requirements: FCC Part 15

Applicant: Silver Spring Networks
575 Broadway Street
Redwood City, CA 94063

FCC ID: OWS-NIC514
IC: 5975A-NIC514

Add passive coupler/external 900 MHz antenna combination ("MPACK" configuration)

II. DESCRIPTION OF EQUIPMENT UNDER TEST (EUT)

The Silver Spring Networks (SSN) NIC514 is a radio module for electric power meter communications use. The board incorporates a 900 MHz frequency hopping i210 Mesh radio and a 2.4 GHz 802.15.4 HAN radio.

The product has been certified with an internal sheet metal antenna and with a board connector provision for connecting an optional external antenna. Now a passive coupler will be placed on the outside housing of the electric meter containing the NIC514 radio module. This configuration will be used when the meters are installed in metal boxes or in other locations where the integral antenna signal will be blocked or shielded.

III. TEST DATES AND TEST LOCATION

Testing was performed at various dates 13-28 October 2010. Tests were performed at:

Compliance Certification Services
47173 Benicia Street
Fremont, CA 94538



T.N. Cokenias
EMC Consultant/Agent for Silver Spring Networks

15 November 2010

MPACK Description

The Meter Patch Antenna Coupler Kit (MPACK) is a very-low-cost alternative mechanism to connect a meter to an external antenna. The MPACK attaches to the outside of the meter cover, directly over the internal antenna, and captures much of the energy from the network interface card and directs it into a coaxial cable which connects to an external antenna. It can be used on any meter where the antenna of the network interface card is sufficiently close to meter cover.

For purposes of equipment authorization, the MPACK is analogous to adding a different type antenna to an existing certified product. Three external antennas were tested with the MPACK coupler:

8.1 dBi monopole omni antenna
0 dBi “puck” omni antenna
8.5 dBic panel antenna

Four different meters were tested with the MPACK and the external antennas:

i210+
Focus”
kV2C
S4e

NOTE: MPACK is only used for 902-298 MHz FHSS operation.

TEST REQUIREMENTS AND TEST PROCEDURES

The meter module software was set to produce the highest certified output power. Module output power was measured at the module test point for Low, Mid, and High channels. The output power at the MPACK cable N-connector were measured for these settings.

Radiated emissions for harmonic and spurious emissions were measured for each antenna at Low, Mid, and High channels for each MPACK/external antenna/electric meter.

Receiver spurious were measured at the MPACK antenna port.

Test Set-up Diagram

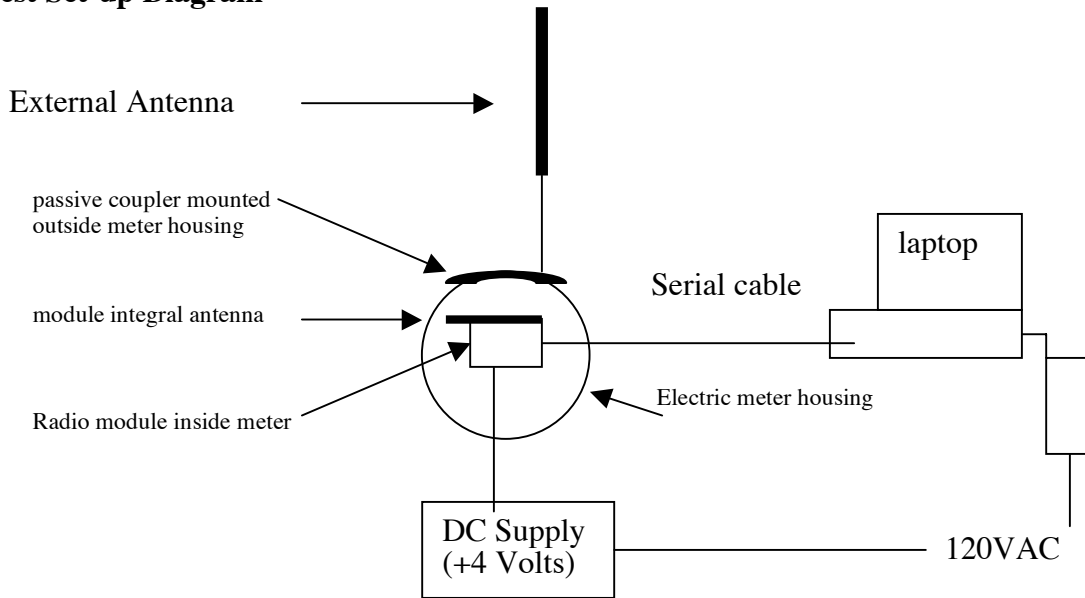

Support Equipment

Equipment	Mfr	Model	Asset No.
DC Power Supply	Agilent	E3610A	2844
Laptop PC	Dell	PP01L	TW-0791UH1280-OC9-6558
AC/DC adapter	CUI Inc.	DSA-60W-20	2607HB

Test Equipment

The following test and measurement equipment was utilized for the tests documented in this report:

TEST EQUIPMENT LIST				
Description	Manufacturer	Model	Asset Number	Cal Due
Spectrum Analyzer, 26.5 GHz	Agilent / HP	E4440A	C01179	08/18/11
Antenna, Bilog, 2 GHz	Sunol Sciences	JB1	C01011	07/12/11
Preamplifier, 1300 MHz	Agilent / HP	8447D	C00885	01/06/11
Antenna, Horn, 18 GHz	EMCO	3115	C00945	06/29/11
Preamplifier, 26.5 GHz	Agilent / HP	8449B	C01052	07/14/11
Power Meter	Agilent / HP	437B	N02778	08/11/12

TEST STANDARDS

All tests were performed in accordance with the applicable procedures called out in the following documents, unless otherwise noted:

FCC 47CFR15

RSS-210 Issue 7: Low power license exempt radio frequency devices (July 2007)
RSS-212: Test Facilities and Test Methods for Radio Equipment

ANSI C63.4 – 2003, American National Standard for Methods of Measurement of Radio-Noise Emissions from Low-Voltage Electrical and Electronic Equipment in the Range of 9 kHz to 40 GHz.

Tests were performed at three frequencies:

900 MHz FHSS

Channel 0 (LOW) – 902.3 MHz
Channel 43 (MID) -915.2 MHz
Channel 82 (HIFH) – 926.9 MHz

TEST RESULTS

Table 1 below lists the output power at the module and the corresponding power measured at the MPACK N-connector. Test results show a slight variation in output levels for the same software setting, due to the fact that two different modules were used and testing was performed on different days.

Table 1: MPACK Output Power Coupling

MPACK Coupling

Meter	FCC ID	Channel	NIC Power dBm	MPACK Power dBm	Coupling dB	Test Date
i210+	OWS-NIC514	0	29.78	21.9	-7.88	13-14 Oct
		43	29.86	22.17	-7.69	
		82	28.85	22.08	-6.77	
Focus	OWS-NIC514	0	29.7	20.7	-9	22/25 Oct
		43	29.8	21.1	-8.7	
		82	29.8	21.8	-8	
kV2c	OWS-NIC514	0	29.7	24.3	-5.4	26/28 Oct
		43	29.8	24	-5.8	
		82	29.8	23.45	-6.35	
S4e	OWS-NIC514	0	29.65	25.5	-4.15	18-Oct
		43	29.85	26.4	-3.45	
		82	29.9	26.9	-3	

Radiated emissions tests were performed at the power output settings in Table 1.

Radiated Test Set-up, 30 MHz - 9.3 GHz

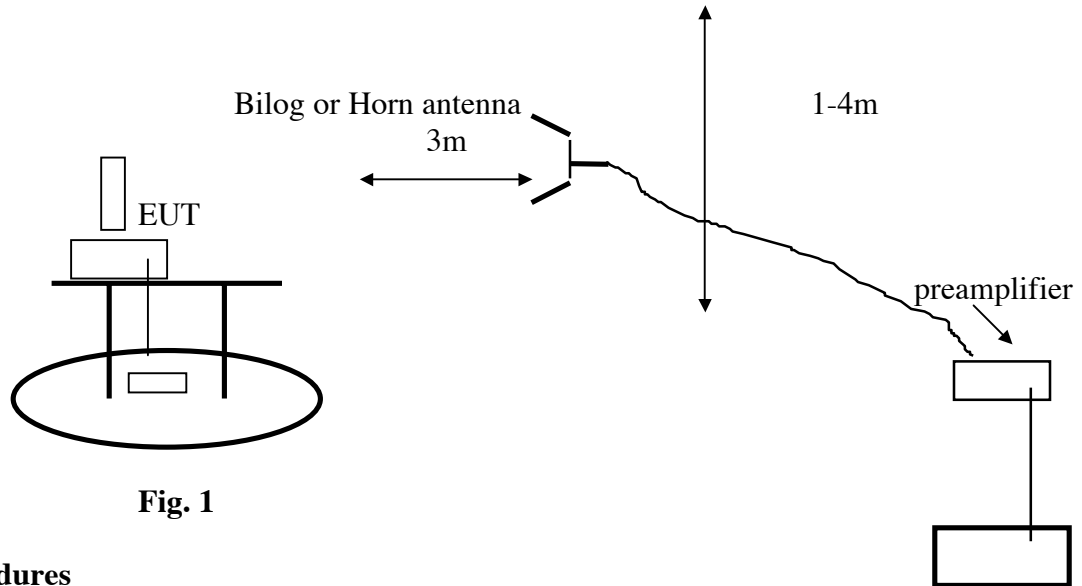

Fig. 1

Test Procedures

Radiated emissions generated by the transmitter portion of the EUT were measured.

1. The EUT was placed on a wooden table resting on a turntable on the test site. The search antenna was placed 3m from the EUT. The EUT antenna was mounted in the with the EUT TX antenna pointed directly to the search antenna.
2. The EUT was configured to deliver the maximum rated output power as documented in Table 1 above.
3. The turntable was slowly rotated to locate the direction of maximum emission at each emission falling in the restricted bands of 15.205.
4. Emissions were investigated to the 10th harmonic of the fundamental.
5. Once maximum direction was determined, the search antenna was raised and lowered in both vertical and horizontal polarizations. The maximum readings so obtained are recorded in the data listed below.

Test Results: Worst-case results are presented. Refer to data sheets below. Restricted band emissions meet 54 dBuV/m. Other undesired emissions from the transmitter meet the -20 dBc requirement in 15.247(d).

15.205 Restricted Frequency Bands

MHz	MHz	MHz	GHz
0.090 - 0.110	16.42 - 16.423	399.9 - 410	4.5 - 5.15
0.495 - 0.505 (1)	16.69475 - 16.69525	608 - 614	5.35 - 5.46
2.1735 - 2.1905	16.80425 - 16.80475	960 - 1240	7.25 - 7.75
4.125 - 4.128	25.5 - 25.67	1300 - 1427	8.025 - 8.5
4.17725 - 4.17775	37.5 - 38.25	1435 - 1626.5	9.0 - 9.2
4.20725 - 4.20775	73 - 74.6	1645.5 - 1646.5	9.3 - 9.5
6.215 - 6.218	74.8 - 75.2	1660 - 1710	10.6 - 12.7
6.26775 - 6.26825	108 - 121.94	1718.8 - 1722.2	13.25 - 13.4
6.31175 - 6.31225	123 - 138	2200 - 2300	14.47 - 14.5
8.291 - 8.294	149.9 - 150.05	2310 - 2390	15.35 - 16.2
8.362 - 8.366	156.52475 -	2483.5 - 2500	17.7 - 21.4
8.37625 - 8.38675	156.52525	2655 - 2900	22.01 - 23.12
8.41425 - 8.41475	156.7 - 156.9	3260 - 3267	23.6 - 24.0
12.29 - 12.293	162.0125 - 167.17	3332 - 3339	31.2 - 31.8
12.51975 - 12.52025	167.72 - 173.2	3345.8 - 3358	36.43 - 36.5
12.57675 - 12.57725	240 - 285	3600 - 4400	
13.36 - 13.41	322 - 335.4		

15.209 General Field Strength Limits

Frequency (MHz)	Field Strength (microvolts/meter)	Measurement Distance (meters)
0.009 - 0.490	2400/F (kHz)	300
0.490 - 1.705	24000/F (kHz)	30
1.705 - 30.0	30	30
30 - 88	100 **	3
88 - 216	150 **	3
216 - 960	200 **	3
Above 960	500	3

i210+ Meter Radiated Emissions Above 1 GHz

8.1dBi Omni Antenna Data Spread Sheet
0 dBi Puck Antenna Data Spread Sheet
8.5 dBi Panel Antenna Data Spread Sheet

High Frequency Measurement																
Compliance Certification Services, Fremont 5m Chamber																
Company: Silver Springs Networks																
Project #: 10U13400																
Date: 10/13/10																
Test Engineer: Doug Anderson																
Configuration: EUT with External 8.1 Omni Antenna																
Mode: Continuous Tx																
Test Equipment:																
Horn 1-18GHz		Pre-amplifer 1-26GHz			Pre-amplifer 26-40GHz			Horn > 18GHz				FCC 15.205				
T73; S/N: 6717 @3m		T144 Miteq 3008A00931														
Hi Frequency Cables																
3' cable 22807700		12' cable 22807600			20' cable 22807500			HPF		Reject Filter		Peak Measurements RBW=VBW=1MHz				
3' cable 22807700		12' cable 22807600			20' cable 22807500			HPF_1.5GHz				Average Measurements RBW=1MHz ; VBW=10Hz				
f GHz	Dist (m)	Read Pk dBuV	Read Avg. dBuV	AF dB/m	CL dB	Amp dB	D Corr dB	Fltr dB	Peak dBuV/m	Avg dBuV/m	Pk Lim dBuV/m	Avg Lim dBuV/m	Pk Mar dB	Avg Mar dB	Notes (V/H)	
Low Channel: 902.3MHz																
1.805	3.0	69.0	68.4	26.6	3.3	-38.3	0.0	0.3	60.8	60.2	0	0	60.8	60.2	V	
2.707	3.0	52.1	48.6	29.1	4.1	-37.4	0.0	0.6	48.5	44.9	74	54	-25.5	-9.1	V	
3.609	3.0	45.6	37.8	31.4	4.8	-36.9	0.0	0.6	45.4	37.7	74	54	-28.6	-16.3	V	
4.512	3.0	44.2	35.0	32.7	5.6	-36.5	0.0	0.6	46.6	37.4	74	54	-27.4	-16.6	V	
5.414	3.0	43.9	34.9	33.8	6.2	-36.3	0.0	0.5	48.1	39.1	74	54	-25.9	-14.9	V	
1.805	3.0	61.3	60.0	26.6	3.3	-38.3	0.0	0.3	53.0	51.8	0	0	53.0	51.8	H	
2.707	3.0	52.4	49.2	29.1	4.1	-37.4	0.0	0.6	48.8	45.6	74	54	-25.2	-8.4	H	
3.609	3.0	43.1	31.3	31.4	4.8	-36.9	0.0	0.6	43.0	31.2	74	54	-31.0	-22.8	H	
4.512	3.0	43.3	34.1	32.7	5.6	-36.5	0.0	0.6	45.6	36.5	74	54	-28.4	-17.5	H	
5.414	3.0	43.5	34.3	33.8	6.2	-36.3	0.0	0.5	47.8	38.5	74	54	-26.2	-15.5	H	
Mid Channel: 915.2MHz																
1.830	3.0	70.0	69.3	26.6	3.3	-38.3	0.0	0.3	62.0	61.3	0	0	62.0	61.3	V	
2.746	3.0	53.3	50.0	29.2	4.1	-37.4	0.0	0.6	49.8	46.6	74	54	-24.2	-7.4	V	
3.661	3.0	44.9	36.5	31.5	4.9	-36.9	0.0	0.6	45.0	36.6	74	54	-29.0	-17.4	V	
4.576	3.0	42.7	32.9	32.8	5.6	-36.5	0.0	0.6	45.2	35.4	74	54	-28.8	-18.6	V	
1.830	3.0	63.1	59.6	26.6	3.3	-38.3	0.0	0.3	55.0	51.6	0	0	55.0	51.6	H	
2.746	3.0	52.4	49.2	29.2	4.1	-37.4	0.0	0.6	48.9	45.7	74	54	-25.1	-8.3	H	
3.661	3.0	42.5	29.4	31.5	4.9	-36.9	0.0	0.6	42.6	29.5	74	54	-31.4	-24.5	H	
4.576	3.0	43.4	33.9	32.8	5.6	-36.5	0.0	0.6	45.9	36.3	74	54	-28.1	-17.7	H	
High Channel: 926.9MHz																
1.854	3.0	73.0	72.5	26.7	3.3	-38.3	0.0	0.3	65.1	64.6	0	0	65.1	64.6	V	
2.781	3.0	53.8	51.3	29.3	4.2	-37.4	0.0	0.6	50.4	48.0	74	54	-23.6	-6.0	V	
3.708	3.0	44.5	35.6	31.6	4.9	-36.8	0.0	0.6	44.8	35.9	74	54	-29.2	-18.1	V	
4.635	3.0	43.4	33.4	32.9	5.7	-36.5	0.0	0.6	45.9	36.0	74	54	-28.1	-18.0	V	
1.854	3.0	63.2	62.2	26.7	3.3	-38.3	0.0	0.3	55.3	54.3	0	0	55.3	54.3	H	
2.781	3.0	52.1	48.8	29.3	4.2	-37.4	0.0	0.6	48.8	45.5	74	54	-25.2	-8.5	H	
4.635	3.0	42.2	31.6	32.9	5.7	-36.5	0.0	0.6	44.8	34.2	74	54	-29.2	-19.8	H	
Rev. 07.22.09																
f	Measurement Frequency					Amp	Preamp Gain					Avg Lim	Average Field Strength Limit			
Dist	Distance to Antenna					D Corr	Distance Correct to 3 meters					Pk Lim	Peak Field Strength Limit			
Read	Analyzer Reading					Avg	Average Field Strength @ 3 m					Avg Mar	Margin vs. Average Limit			
AF	Antenna Factor					Peak	Calculated Peak Field Strength					Pk Mar	Margin vs. Peak Limit			
CL	Cable Loss					HPF	High Pass Filter									

High Frequency Measurement																
Compliance Certification Services, Fremont 5m Chamber																
Company: Silver Springs Networks																
Project #: 10U13400																
Date: 10/13/10																
Test Engineer: Doug Anderson																
Configuration: EUT with External 0 dBi Puck Antenna																
Mode: Continuous Tx																
Test Equipment:																
Horn 1-18GHz		Pre-amplifier 1-26GHz			Pre-amplifier 26-40GHz			Horn > 18GHz								
T73; S/N: 6717 @3m		T144 Miteq 3008A00931										FCC 15.205				
Hi Frequency Cables																
3' cable 22807700		12' cable 22807600			20' cable 22807500			HPF		Reject Filter		Peak Measurements				
3' cable 22807700		12' cable 22807600			20' cable 22807500			HPF_1.5GHz				RBW=VBW=1MHz				
Average Measurements																
RBW=1MHz ; VBW=10Hz																
f GHz	Dist (m)	Read Pk dBuV	Read Avg. dBuV	AF dB/m	CL dB	Amp dB	D Corr dB	Filtr dB	Peak dBuV/m	Avg dBuV/m	Pk Lim dBuV/m	Avg Lim dBuV/m	Pk Mar dB	Avg Mar dB	Notes (V/H)	
Low Channel: 902.3MHz																
1.805	3.0	72.6	72.0	26.6	3.3	-38.3	0.0	0.3	64.4	63.8	0	0	64.4	63.8	V	
2.707	3.0	54.7	52.5	29.1	4.1	-37.4	0.0	0.6	51.1	48.8	74	54	-22.9	-5.2	V	
3.609	3.0	45.0	36.5	31.4	4.8	-36.9	0.0	0.6	44.9	36.4	74	54	-29.1	-17.6	V	
4.512	3.0	44.0	35.2	32.7	5.6	-36.5	0.0	0.6	46.3	37.6	74	54	-27.7	-16.4	V	
5.414	3.0	43.0	33.7	33.8	6.2	-36.3	0.0	0.5	47.3	37.9	74	54	-26.7	-16.1	V	
1.805	3.0	64.3	63.4	26.6	3.3	-38.3	0.0	0.3	56.1	55.2	0	0	56.1	55.2	H	
2.707	3.0	51.4	48.0	29.1	4.1	-37.4	0.0	0.6	47.8	44.4	74	54	-26.2	-9.6	H	
3.609	3.0	43.7	33.0	31.4	4.8	-36.9	0.0	0.6	43.6	32.8	74	54	-30.4	-21.2	H	
4.512	3.0	43.5	32.8	32.7	5.6	-36.5	0.0	0.6	45.8	35.1	74	54	-28.2	-18.9	H	
5.414	3.0	42.9	32.7	33.8	6.2	-36.3	0.0	0.5	47.2	37.0	74	54	-26.8	-17.0	H	
Mid Channel: 915.2MHz																
1.830	3.0	74.1	73.5	26.6	3.3	-38.3	0.0	0.3	66.0	65.4	0	0	66.0	65.4	V	
2.746	3.0	53.6	51.0	29.2	4.1	-37.4	0.0	0.6	50.2	47.5	74	54	-23.8	-6.5	V	
3.661	3.0	42.9	31.2	31.5	4.9	-36.9	0.0	0.6	43.0	31.3	74	54	-31.0	-22.7	V	
4.576	3.0	43.1	33.3	32.8	5.6	-36.5	0.0	0.6	45.6	35.8	74	54	-28.4	-18.2	V	
1.830	3.0	64.7	61.5	26.6	3.3	-38.3	0.0	0.3	56.6	53.4	0	0	56.6	53.4	H	
2.746	3.0	51.1	47.1	29.2	4.1	-37.4	0.0	0.6	47.6	43.6	74	54	-26.4	-10.4	H	
4.576	3.0	42.6	32.5	32.8	5.6	-36.5	0.0	0.6	45.1	35.0	74	54	-28.9	-19.0	H	
High Channel: 926.9MHz																
1.854	3.0	66.7	66.0	26.7	3.3	-38.3	0.0	0.3	58.8	58.1	0	0	58.8	58.1	V	
2.781	3.0	51.4	47.7	29.3	4.2	-37.4	0.0	0.6	48.1	44.3	74	54	-25.9	-9.7	V	
3.708	3.0	43.1	30.9	31.6	4.9	-36.8	0.0	0.6	43.4	31.2	74	54	-30.6	-22.8	V	
4.635	3.0	42.9	33.8	32.9	5.7	-36.5	0.0	0.6	45.5	36.4	74	54	-28.5	-17.6	V	
1.854	3.0	57.8	55.0	26.7	3.3	-38.3	0.0	0.3	49.9	47.1	0	0	49.9	47.1	H	
2.781	3.0	48.2	42.4	29.3	4.2	-37.4	0.0	0.6	44.8	39.1	74	54	-29.2	-14.9	H	
4.635	3.0	42.1	30.9	32.9	5.7	-36.5	0.0	0.6	44.7	33.5	74	54	-29.3	-20.5	H	
Rev. 07.22.09																
f	Measurement Frequency					Amp	Preamp Gain					Avg Lim	Average Field Strength Limit			
Dist	Distance to Antenna					D Corr	Distance Correct to 3 meters					Pk Lim	Peak Field Strength Limit			
Read	Analyzer Reading					Avg	Average Field Strength @ 3 m					Avg Mar	Margin vs. Average Limit			
AF	Antenna Factor					Peak	Calculated Peak Field Strength					Pk Mar	Margin vs. Peak Limit			
CL	Cable Loss					HPF	High Pass Filter									

High Frequency Measurement																
Compliance Certification Services, Fremont 5m Chamber																
Company: Silver Springs Networks																
Project #: 10U13400																
Date: 10/13/10																
Test Engineer: Doug Anderson																
Configuration: EUT with External Laird Pannel Antenna																
Mode: Continuous Tx																
Test Equipment:																
Horn 1-18GHz		Pre-amplifier 1-26GHz			Pre-amplifier 26-40GHz			Horn > 18GHz				FCC 15.205				
T73; S/N: 6717 @3m		T144 Miteq 3008A00931														
Hi Frequency Cables																
3' cable 22807700		12' cable 22807600			20' cable 22807500			HPF		Reject Filter		Peak Measurements				
3' cable 22807700		12' cable 22807600			20' cable 22807500			HPF_1.5GHz				RBW=VBW=1MHz				
Average Measurements																
RBW=1MHz ; VBW=10Hz																
f GHz	Dist (m)	Read Pk dBuV	Read Avg. dBuV	AF dB/m	CL dB	Amp dB	D Corr dB	Fltr dB	Peak dBuV/m	Avg dBuV/m	Pk Lim dBuV/m	Avg Lim dBuV/m	Pk Mar dB	Avg Mar dB	Notes (V/H)	
Low Channel: 902.3MHz																
1.805	3.0	59.2	57.8	26.6	3.3	-38.3	0.0	0.3	51.0	49.6	0	0	51.0	49.6	V	
2.707	3.0	48.9	44.3	29.1	4.1	-37.4	0.0	0.6	45.3	40.6	74	54	-28.7	-13.4	V	
3.609	3.0	42.1	30.3	31.4	4.8	-36.9	0.0	0.6	42.0	30.2	74	54	-32.0	-23.8	V	
4.512	3.0	43.6	34.7	32.7	5.6	-36.5	0.0	0.6	46.0	37.1	74	54	-28.0	-16.9	V	
5.414	3.0	43.1	33.8	33.8	6.2	-36.3	0.0	0.5	47.4	38.0	74	54	-26.6	-16.0	V	
1.805	3.0	54.1	50.7	26.6	3.3	-38.3	0.0	0.3	45.9	42.5	0	0	45.9	42.5	H	
2.707	3.0	47.7	40.9	29.1	4.1	-37.4	0.0	0.6	44.1	37.3	74	54	-29.9	-16.7	H	
3.609	3.0	43.5	30.9	31.4	4.8	-36.9	0.0	0.6	43.4	30.8	74	54	-30.6	-23.2	H	
4.512	3.0	43.3	32.8	32.7	5.6	-36.5	0.0	0.6	45.7	35.2	74	54	-28.3	-18.8	H	
5.414	3.0	41.8	31.2	33.8	6.2	-36.3	0.0	0.5	46.1	35.5	74	54	-27.9	-18.5	H	
Mid Channel: 915.2MHz																
1.830	3.0	66.0	64.4	26.6	3.3	-38.3	0.0	0.3	58.0	56.3	0	0	58.0	56.3	V	
2.746	3.0	50.9	47.5	29.2	4.1	-37.4	0.0	0.6	47.4	44.0	74	54	-26.6	-10.0	V	
3.661	3.0	44.5	33.9	31.5	4.9	-36.9	0.0	0.6	44.6	34.0	74	54	-29.4	-20.0	V	
4.576	3.0	42.6	31.6	32.8	5.6	-36.5	0.0	0.6	45.0	34.1	74	54	-29.0	-19.9	V	
1.830	3.0	57.4	52.8	26.6	3.3	-38.3	0.0	0.3	49.3	44.8	0	0	49.3	44.8	H	
2.746	3.0	50.7	46.6	29.2	4.1	-37.4	0.0	0.6	47.2	43.2	74	54	-26.8	-10.8	H	
4.576	3.0	43.9	35.1	32.8	5.6	-36.5	0.0	0.6	46.3	37.6	74	54	-27.7	-16.4	H	
High Channel: 926.9MHz																
1.854	3.0	68.4	67.7	26.7	3.3	-38.3	0.0	0.3	60.5	59.8	0	0	60.5	59.8	V	
2.781	3.0	52.0	49.1	29.3	4.2	-37.4	0.0	0.6	48.6	45.8	74	54	-25.4	-8.2	V	
3.708	3.0	43.9	34.3	31.6	4.9	-36.8	0.0	0.6	44.2	34.6	74	54	-29.8	-19.4	V	
4.635	3.0	44.6	36.6	32.9	5.7	-36.5	0.0	0.6	47.2	39.2	74	54	-26.8	-14.8	V	
1.854	3.0	59.2	57.3	26.7	3.3	-38.3	0.0	0.3	51.3	49.4	0	0	51.3	49.4	H	
2.781	3.0	48.9	43.3	29.3	4.2	-37.4	0.0	0.6	45.5	40.0	74	54	-28.5	-14.0	H	
4.635	3.0	42.6	33.2	32.9	5.7	-36.5	0.0	0.6	45.2	35.8	74	54	-28.8	-18.2	H	
Rev. 07.22.09																
f	Measurement Frequency					Amp	Preamp Gain					Avg Lim	Average Field Strength Limit			
Dist	Distance to Antenna					D Corr	Distance Correct to 3 meters					Pk Lim	Peak Field Strength Limit			
Read	Analyzer Reading					Avg	Average Field Strength @ 3 m					Avg Mar	Margin vs. Average Limit			
AF	Antenna Factor					Peak	Calculated Peak Field Strength					Pk Mar	Margin vs. Peak Limit			
CL	Cable Loss					HPF	High Pass Filter									

Focus Meter Radiated Emissions Above 1 GHz

8.1dBi Omni Antenna Data Spread Sheet

0 dBi Puck Antenna Data Spread Sheet

8.5 dBi Panel Antenna Data Spread Sheet

High Frequency Measurement																	
Compliance Certification Services, Fremont 5m Chamber																	
Company:		Silver Spring Networks															
Project #:		10U13400															
Date:		10/25/10															
Test Engineer:		Thanh Nguyen															
Configuration:		EUT Model Focus+(FCC ID OWS-NIC514) new card with MPACK 8.IdBi Ant															
Mode:		Tx normal															
Test Equipment:																	
Horn 1-18GHz				Pre-amplifier 1-26GHz				Pre-amplifier 26-40GHz				Horn > 18GHz				FCC 15.205	
T73; S/N: 6717 @3m				T144 Miteq 3008A00931													
HI Frequency Cables																	
3' cable 22807700				12' cable 22807600				20' cable 22807500				HPF				Reject Filter	
3' cable 22807700				12' cable 22807600				20' cable 22807500				HPF_1.5GHz					
Peak Measurements RBW=VBW=1MHz Average Measurements RBW=1MHz ; VBW=10Hz																	
f GHz	Dist (m)	Read Pk dBuV	Read Avg. dBuV	AF dB/m	CL dB	Amp dB	D Corr dB	Filtr dB	Peak dBuV/m	Avg dBuV/m	Pk Lim dBuV/m	Avg Lim dBuV/m	Pk Mar dB	Avg Mar dB	Notes (V/H)		
Channel 0 , 902.3MHz																	
1.805	3.0	58.3	57.0	26.6	3.3	-38.3	0.0	0.3	50.1	48.8	0	0	50.1	48.8	V		
2.707	3.0	47.8	43.3	29.1	4.1	-37.4	0.0	0.6	44.2	39.7	74	54	-29.8	-14.3	V		
3.609	3.0	42.4	31.3	31.4	4.8	-36.9	0.0	0.6	42.3	31.2	74	54	-31.7	-22.8	V		
4.511	3.0	41.2	29.2	32.7	5.6	-36.5	0.0	0.6	43.6	31.5	74	54	-30.4	-22.5	V		
5.414	3.0	45.5	35.1	33.8	6.2	-36.3	0.0	0.5	49.8	39.4	74	54	-24.2	-14.6	V		
6.316	3.0	43.6	29.4	34.3	6.7	-36.3	0.0	0.5	48.8	34.6	0	0	48.8	34.6	V		
7.218	3.0	43.2	34.5	35.2	7.2	-36.2	0.0	0.6	50.0	41.2	0	0	50.0	41.2	V		
8.121	3.0	44.0	35.8	36.4	7.7	-36.2	0.0	0.7	52.6	44.5	74	54	-21.4	-9.5	V		
9.023	3.0	42.9	35.8	37.2	8.2	-36.7	0.0	0.7	52.4	45.2	74	54	-21.6	-8.8	V		
1.805	3.0	57.3	56.0	26.6	3.3	-38.3	0.0	0.3	49.1	47.8	0	0	49.1	47.8	V		
2.707	3.0	47.8	43.3	29.1	4.1	-37.4	0.0	0.6	44.2	39.7	74	54	-29.8	-14.3	H		
3.609	3.0	42.4	31.3	31.4	4.8	-36.9	0.0	0.6	42.3	31.2	74	54	-31.7	-22.8	H		
4.511	3.0	41.2	29.2	32.7	5.6	-36.5	0.0	0.6	43.6	31.5	74	54	-30.4	-22.5	H		
5.414	3.0	45.5	35.1	33.8	6.2	-36.3	0.0	0.5	49.8	39.4	74	54	-24.2	-14.6	H		
6.316	3.0	43.6	29.4	34.3	6.7	-36.3	0.0	0.5	48.8	34.6	0	0	48.8	34.6	V		
7.218	3.0	43.2	34.5	35.2	7.2	-36.2	0.0	0.6	50.0	41.2	0	0	50.0	41.2	V		
8.120	3.0	44.0	35.8	36.4	7.7	-36.2	0.0	0.7	52.6	44.4	74	54	-21.4	-9.6	H		
9.023	3.0	42.9	35.8	37.2	8.2	-36.7	0.0	0.7	52.4	45.2	74	54	-21.6	-8.8	V		
Channel 43 , 915.167MHz																	
2.746	3.0	47.7	42.1	29.2	4.1	-37.4	0.0	0.6	44.2	38.6	74	54	-29.8	-15.4	V		
3.661	3.0	43.8	34.5	31.5	4.9	-36.9	0.0	0.6	43.9	34.6	74	54	-30.1	-19.4	V		
4.578	3.0	40.3	32.1	32.8	5.6	-36.5	0.0	0.6	42.8	34.6	74	54	-31.2	-19.4	V		
7.322	3.0	42.4	35.1	35.3	7.3	-36.2	0.0	0.6	49.3	42.1	74	54	-24.7	-11.9	V		
8.237	3.0	41.1	31.2	36.5	7.8	-36.3	0.0	0.7	49.8	39.9	74	54	-24.2	-14.1	V		
9.152	3.0	40.6	28.3	37.2	8.3	-36.7	0.0	0.7	50.1	37.8	74	54	-23.9	-16.2	V		
2.746	3.0	47.5	41.4	29.2	4.1	-37.4	0.0	0.6	44.0	37.9	74	54	-30.0	-16.1	H		
3.661	3.0	40.6	32.5	31.5	4.9	-36.9	0.0	0.6	40.7	32.6	74	54	-33.3	-21.4	H		
4.576	3.0	41.4	32.3	32.8	5.6	-36.5	0.0	0.6	43.8	34.7	74	54	-30.2	-19.3	H		
7.322	3.0	44.4	35.6	35.3	7.3	-36.2	0.0	0.6	51.4	42.6	74	54	-22.6	-11.4	H		
8.238	3.0	43.3	33.3	36.5	7.8	-36.3	0.0	0.7	52.0	42.0	74	54	-22.0	-12.0	H		
9.152	3.0	40.2	30.3	37.2	8.3	-36.7	0.0	0.7	49.7	39.8	74	54	-24.3	-14.2	H		
Channel 82 , 926.95MHz																	
2.780	3.0	46.8	40.7	29.3	4.2	-37.4	0.0	0.6	43.5	37.4	74	54	-30.5	-16.6	V		
3.708	3.0	43.0	34.1	31.6	4.9	-36.8	0.0	0.6	43.3	34.4	74	54	-30.7	-19.6	V		
4.634	3.0	42.4	31.9	32.9	5.7	-36.5	0.0	0.6	45.0	34.5	74	54	-29.0	-19.5	V		
7.416	3.0	43.2	34.1	35.5	7.3	-36.2	0.0	0.6	50.4	41.3	74	54	-23.6	-12.7	V		
8.341	3.0	42.0	30.6	36.6	7.8	-36.3	0.0	0.7	50.8	39.4	74	54	-23.2	-14.6	V		
2.780	3.0	46.7	41.3	29.3	4.2	-37.4	0.0	0.6	43.4	38.0	74	54	-30.6	-16.0	H		
3.708	3.0	42.1	32.4	31.6	4.9	-36.8	0.0	0.6	42.4	32.7	74	54	-31.6	-21.3	H		
4.635	3.0	40.7	31.3	32.9	5.7	-36.5	0.0	0.6	43.3	33.8	74	54	-30.7	-20.2	H		
7.415	3.0	40.6	32.9	35.5	7.3	-36.2	0.0	0.6	47.8	40.1	74	54	-26.2	-13.9	H		
8.341	3.0	41.1	29.6	36.6	7.8	-36.3	0.0	0.7	50.0	38.4	74	54	-24.0	-15.6	H		
Rev. 07.22.09																	
f	Measurement Frequency					Amp	Preamp Gain					Avg Lim	Average Field Strength Limit				
Dist	Distance to Antenna					D Corr	Distance Correct to 3 meters					Pk Lim	Peak Field Strength Limit				
Read	Analyzer Reading					Avg	Average Field Strength @ 3 m					Avg Mar	Margin vs. Average Limit				
AF	Antenna Factor					Peak	Calculated Peak Field Strength					Pk Mar	Margin vs. Peak Limit				
CL	Cable Loss					HPF	High Pass Filter										

High Frequency Measurement Compliance Certification Services, Fremont 5m Chamber																
Company:		Silver Spring Networks														
Project #:		10U13400														
Date:		10/25/10														
Test Engineer:		Thanh Nguyen														
Configuration:		EUT Model Focus+(FCC ID OWS-NIC514) new card with Puck Ant														
Mode:		Tx normal														
Test Equipment:																
Horn 1-18GHz		Pre-amplifier 1-26GHz			Pre-amplifier 26-40GHz			Horn > 18GHz								
T73; S/N: 6717 @3m		T144 Miteq 3008A00931														
FCC 15.205																
3' cable 22807700		12' cable 22807600			20' cable 22807500			HPF		Reject Filter		Peak Measurements				
3' cable 22807700		12' cable 22807600			20' cable 22807500			HPF_1.5GHz				RBW=VBW=1MHz				
Average Measurements																
RBW=1MHz ; VBW=10Hz																
f GHz	Dist (m)	Read Pk dBuV	Read Avg. dBuV	AF dB/m	CL dB	Amp dB	D Corr dB	Filtr dB	Peak dBuV/m	Avg dBuV/m	Pk Lim dBuV/m	Avg Lim dBuV/m	Pk Mar dB	Avg Mar dB	Notes (V/H)	
Channel 0 , 902.3MHz																
1.804	3.0	61.1	60.2	26.6	3.3	-38.3	0.0	0.3	52.9	52.0	0	0	52.9	52.0	V	
2.707	3.0	46.2	40.1	29.1	4.1	-37.4	0.0	0.6	42.6	36.4	74	54	-31.4	-17.6	V	
3.609	3.0	41.9	30.3	31.4	4.8	-36.9	0.0	0.6	41.8	30.2	74	54	-32.2	-23.8	V	
4.511	3.0	40.7	28.3	32.7	5.6	-36.5	0.0	0.6	43.1	30.6	74	54	-30.9	-23.4	V	
5.414	3.0	42.0	32.8	33.8	6.2	-36.3	0.0	0.5	46.2	37.0	74	54	-27.8	-17.0	V	
6.316	3.0	39.9	27.4	34.3	6.7	-36.3	0.0	0.5	45.1	32.6	0	0	45.1	32.6	V	
7.218	3.0	40.3	32.6	35.2	7.2	-36.2	0.0	0.6	47.0	39.4	0	0	47.0	39.4	V	
8.120	3.0	41.4	27.8	36.4	7.7	-36.2	0.0	0.7	50.0	36.4	74	54	-24.0	-17.6	V	
9.023	3.0	40.4	27.9	37.2	8.2	-36.7	0.0	0.7	49.8	37.3	74	54	-24.2	-16.7	V	
1.804	3.0	60.2	58.9	26.6	3.3	-38.3	0.0	0.3	52.0	50.7	0	0	52.0	50.7	H	
2.707	3.0	49.3	45.6	29.1	4.1	-37.4	0.0	0.6	45.7	41.9	74	54	-28.3	-12.1	H	
3.609	3.0	41.6	30.8	31.4	4.8	-36.9	0.0	0.6	41.5	30.7	74	54	-32.5	-23.3	H	
4.511	3.0	40.5	27.6	32.7	5.6	-36.5	0.0	0.6	42.9	29.9	74	54	-31.1	-24.1	H	
5.414	3.0	42.1	33.2	33.8	6.2	-36.3	0.0	0.5	46.4	37.5	74	54	-27.6	-16.5	H	
6.316	3.0	42.4	35.1	34.3	6.7	-36.3	0.0	0.5	47.6	40.3	0	0	47.6	40.3	H	
7.218	3.0	42.4	31.2	35.2	7.2	-36.2	0.0	0.6	49.1	38.0	0	0	49.1	38.0	H	
8.120	3.0	41.6	32.6	36.4	7.7	-36.2	0.0	0.7	50.2	41.2	74	54	-23.8	-12.8	H	
9.023	3.0	39.7	28.2	37.2	8.2	-36.7	0.0	0.7	49.1	37.6	74	54	-24.9	-16.4	V	
Channel 43 , 915.167MHz																
1.830	3.0	52.9	49.2	26.6	3.3	-38.3	0.0	0.3	44.8	41.2	0	0	44.8	41.2	V	
2.746	3.0	47.7	42.1	29.2	4.1	-37.4	0.0	0.6	44.2	38.6	74	54	-29.8	-15.4	V	
3.661	3.0	43.8	34.5	31.5	4.9	-36.9	0.0	0.6	43.9	34.6	74	54	-30.1	-19.4	V	
4.578	3.0	40.3	32.1	32.8	5.6	-36.5	0.0	0.6	42.8	34.6	74	54	-31.2	-19.4	V	
5.491	3.0	43.3	36.3	33.9	6.2	-36.4	0.0	0.5	47.6	40.6	0	0	47.6	40.6	V	
6.407	3.0	40.5	35.2	34.3	6.8	-36.3	0.0	0.5	45.9	40.6	0	0	45.9	40.6	V	
7.322	3.0	42.4	35.1	35.3	7.3	-36.2	0.0	0.6	49.3	42.1	74	54	-24.7	-11.9	V	
8.237	3.0	41.1	31.2	36.5	7.8	-36.3	0.0	0.7	49.8	39.9	74	54	-24.2	-14.1	V	
9.152	3.0	40.6	28.3	37.2	8.3	-36.7	0.0	0.7	50.1	37.8	74	54	-23.9	-16.2	V	
1.830	3.0	56.7	54.3	26.6	3.3	-38.3	0.0	0.3	48.6	46.3	0	0	48.6	46.3	H	
2.746	3.0	47.5	41.4	29.2	4.1	-37.4	0.0	0.6	44.0	37.9	74	54	-30.0	-16.1	H	
3.661	3.0	40.6	32.5	31.5	4.9	-36.9	0.0	0.6	40.7	32.6	74	54	-33.3	-21.4	H	
4.576	3.0	41.4	32.3	32.8	5.6	-36.5	0.0	0.6	43.8	34.7	74	54	-30.2	-19.3	H	
5.491	3.0	42.4	30.3	33.9	6.2	-36.4	0.0	0.5	46.7	34.6	0	0	46.7	34.6	H	
6.406	3.0	40.4	32.2	34.3	6.8	-36.3	0.0	0.5	45.7	37.5	0	0	45.7	37.5	H	
7.322	3.0	44.4	35.6	35.3	7.3	-36.2	0.0	0.6	51.4	42.6	74	54	-22.6	-11.4	H	
8.238	3.0	43.3	33.3	36.5	7.8	-36.3	0.0	0.7	52.0	42.0	74	54	-22.0	-12.0	H	
9.152	3.0	40.2	30.3	37.2	8.3	-36.7	0.0	0.7	49.7	39.8	74	54	-24.3	-14.2	H	
Channel 82 , 926.95MHz																
1.854	3.0	53.7	50.5	26.7	3.3	-38.3	0.0	0.3	45.8	42.6	0	0	45.8	42.6	V	
2.780	3.0	46.8	40.7	29.3	4.2	-37.4	0.0	0.6	43.5	37.4	74	54	-30.5	-16.6	V	
3.708	3.0	43.0	34.1	31.6	4.9	-36.8	0.0	0.6	43.3	34.4	74	54	-30.7	-19.6	V	
4.634	3.0	42.4	31.9	32.9	5.7	-36.5	0.0	0.6	45.0	34.5	74	54	-29.0	-19.5	V	
5.561	3.0	47.4	43.3	34.0	6.3	-36.4	0.0	0.5	51.7	47.6	0	0	51.7	47.6	V	
6.488	3.0	45.2	40.2	34.4	6.8	-36.3	0.0	0.5	50.7	45.7	0	0	50.7	45.7	V	
7.416	3.0	43.2	34.1	35.5	7.3	-36.2	0.0	0.6	50.4	41.3	74	54	-23.6	-12.7	V	
8.341	3.0	42.0	30.6	36.6	7.8	-36.3	0.0	0.7	50.8	39.4	74	54	-23.2	-14.6	V	
9.269	3.0	41.7	31.8	37.3	8.3	-36.8	0.0	0.7	51.2	41.4	0	0	51.2	41.4	V	
1.854	3.0	60.0	58.6	26.7	3.3	-38.3	0.0	0.3	52.1	50.7	0	0	52.1	50.7	H	
2.780	3.0	46.7	41.3	29.3	4.2	-37.4	0.0	0.6	43.4	38.0	74	54	-30.6	-16.0	H	
3.708	3.0	42.1	32.4	31.6	4.9	-36.8	0.0	0.6	42.4	32.7	74	54	-31.6	-21.3	H	
4.635	3.0	40.7	31.3	32.9	5.7	-36.5	0.0	0.6	43.3	33.8	74	54	-30.7	-20.2	H	
5.561	3.0	44.3	40.1	34.0	6.3	-36.4	0.0	0.5	48.6	44.5	0	0	48.6	44.5	H	
6.488	3.0	38.3	32.5	34.4	6.8	-36.3	0.0	0.5	43.7	37.9	0	0	43.7	37.9	H	
7.415	3.0	40.6	32.9	35.5	7.3	-36.2	0.0	0.6	47.8	40.1	74	54	-26.2	-13.9	H	
8.341	3.0	41.1	29.6	36.6	7.8	-36.3	0.0	0.7	50.0	38.4	74	54	-24.0	-15.6	H	
9.269	3.0	39.6	29.8	37.3	8.3	-36.8	0.0	0.7	49.1	39.4	0	0	49.1	39.4	H	
Rev. 07.22.09																
f	Measurement Frequency					Amp	Preamp Gain					Avg Lim	Average Field Strength Limit			
Dist	Distance to Antenna					D Corr	Distance Correct to 3 meters					Pk Lim	Peak Field Strength Limit			
Read	Analyzer Reading					Avg	Average Field Strength @ 3 m					Avg Mar	Margin vs. Average Limit			
AF	Antenna Factor					Peak	Calculated Peak Field Strength					Pk Mar	Margin vs. Peak Limit			
CL	Cable Loss					HPF	High Pass Filter									

High Frequency Measurement																	
Compliance Certification Services, Fremont 5m Chamber																	
Company:		Silver Spring Networks															
Project #:		10U13400															
Date:		10/25/10															
Test Engineer:		Thanh Nguyen															
Configuration:		EUT Model Focus+(FCC ID OWS-NIC514) new card with Panel Ant															
Mode:		Tx normal															
Test Equipment:																	
Horn 1-18GHz			Pre-amplifier 1-26GHz			Pre-amplifier 26-40GHz			Horn > 18GHz								
T73; S/N: 6717 @3m			T144 Miteq 3008A00931														
Hi Frequency Cables																	
3' cable 22807700			12' cable 22807600			20' cable 22807500			HPF			Reject Filter			Peak Measurements		
3' cable 22807700			12' cable 22807600			20' cable 22807500			HPF_1.5GHz						RBW=VBW=1MHz Average Measurements RBW=1MHz ; VBW=10Hz		
f GHz	Dist (m)	Read Pk dBuV	Read Avg. dBuV	AF dB/m	CL dB	Amp dB	D Corr dB	Fltr dB	Peak dBuV/m	Avg dBuV/m	Pk Lim dBuV/m	Avg Lim dBuV/m	Pk Mar dB	Avg Mar dB	Notes (V/H)		
Channel 0 , 902.3MHz																	
1.804	3.0	61.6	60.3	26.6	3.3	-38.3	0.0	0.3	53.4	52.1	0	0	53.4	52.1	V		
2.707	3.0	46.3	38.2	29.1	4.1	-37.4	0.0	0.6	42.7	34.6	74	54	-31.3	-19.4	V		
3.609	3.0	43.6	33.6	31.4	4.8	-36.9	0.0	0.6	43.5	33.5	74	54	-30.5	-20.5	V		
4.511	3.0	41.8	29.6	32.7	5.6	-36.5	0.0	0.6	44.2	32.0	74	54	-29.8	-22.0	V		
5.414	3.0	41.0	30.5	33.8	6.2	-36.3	0.0	0.5	45.2	34.7	74	54	-28.8	-19.3	V		
6.316	3.0	39.7	29.6	34.3	6.7	-36.3	0.0	0.5	44.9	34.8	0	0	44.9	34.8	V		
7.218	3.0	43.0	34.4	35.2	7.2	-36.2	0.0	0.6	49.8	41.2	0	0	49.8	41.2	V		
8.120	3.0	40.8	28.4	36.4	7.7	-36.2	0.0	0.7	49.4	37.0	74	54	-24.6	-17.0	V		
9.023	3.0	39.8	27.9	37.2	8.2	-36.7	0.0	0.7	49.3	37.3	74	54	-24.7	-16.7	V		
1.804	3.0	59.4	58.0	26.6	3.3	-38.3	0.0	0.3	51.2	49.8	0	0	51.2	49.8	H		
2.707	3.0	48.4	42.8	29.1	4.1	-37.4	0.0	0.6	44.8	39.2	74	54	-29.2	-14.8	H		
3.609	3.0	42.6	30.4	31.4	4.8	-36.9	0.0	0.6	42.5	30.3	74	54	-31.5	-23.7	H		
4.511	3.0	40.6	27.9	32.7	5.6	-36.5	0.0	0.6	43.0	30.2	74	54	-31.0	-23.8	H		
5.414	3.0	42.4	35.7	33.8	6.2	-36.3	0.0	0.5	46.6	39.9	74	54	-27.4	-14.1	H		
6.316	3.0	40.4	34.2	34.3	6.7	-36.3	0.0	0.5	45.6	39.4	0	0	45.6	39.4	H		
7.218	3.0	41.8	30.0	35.2	7.2	-36.2	0.0	0.6	48.5	36.8	0	0	48.5	36.8	H		
8.120	3.0	41.7	32.0	36.4	7.7	-36.2	0.0	0.7	50.3	40.6	74	54	-23.7	-13.4	H		
9.023	3.0	39.9	27.6	37.2	8.2	-36.7	0.0	0.7	49.3	37.0	74	54	-24.7	-17.0	V		
Channel 43 , 915.167MHz																	
1.830	3.0	52.9	49.2	26.6	3.3	-38.3	0.0	0.3	44.8	41.2	0	0	44.8	41.2	V		
2.746	3.0	47.7	42.1	29.2	4.1	-37.4	0.0	0.6	44.2	38.6	74	54	-29.8	-15.4	V		
3.661	3.0	43.8	34.5	31.5	4.9	-36.9	0.0	0.6	43.9	34.6	74	54	-30.1	-19.4	V		
4.578	3.0	40.3	32.1	32.8	5.6	-36.5	0.0	0.6	42.8	34.6	74	54	-31.2	-19.4	V		
5.491	3.0	43.3	36.3	33.9	6.2	-36.4	0.0	0.5	47.6	40.6	0	0	47.6	40.6	V		
6.407	3.0	40.5	35.2	34.3	6.8	-36.3	0.0	0.5	45.9	40.6	0	0	45.9	40.6	V		
7.322	3.0	42.4	35.1	35.3	7.3	-36.2	0.0	0.6	49.3	42.1	74	54	-24.7	-11.9	V		
8.237	3.0	41.1	31.2	36.5	7.8	-36.3	0.0	0.7	49.8	39.9	74	54	-24.2	-14.1	V		
9.152	3.0	40.6	28.3	37.2	8.3	-36.7	0.0	0.7	50.1	37.8	74	54	-23.9	-16.2	V		
1.830	3.0	56.9	54.4	26.6	3.3	-38.3	0.0	0.3	48.9	46.4	0	0	48.9	46.4	H		
2.746	3.0	49.3	44.6	29.2	4.1	-37.4	0.0	0.6	45.8	41.2	74	54	-28.2	-12.8	H		
3.661	3.0	41.6	33.6	31.5	4.9	-36.9	0.0	0.6	41.7	33.7	74	54	-32.3	-20.3	H		
4.576	3.0	40.5	31.1	32.8	5.6	-36.5	0.0	0.6	43.0	33.6	74	54	-31.0	-20.4	H		
5.491	3.0	43.6	31.3	33.9	6.2	-36.4	0.0	0.5	47.9	35.6	0	0	47.9	35.6	H		
6.406	3.0	41.4	33.5	34.3	6.8	-36.3	0.0	0.5	46.7	38.9	0	0	46.7	38.9	H		
7.322	3.0	43.8	35.0	35.3	7.3	-36.2	0.0	0.6	50.8	42.0	74	54	-23.2	-12.0	H		
8.238	3.0	42.4	32.6	36.5	7.8	-36.3	0.0	0.7	51.1	41.3	74	54	-22.9	-12.7	H		
9.152	3.0	41.9	31.7	37.2	8.3	-36.7	0.0	0.7	51.4	41.2	74	54	-22.6	-12.8	H		
Channel 82 , 926.95MHz																	
1.854	3.0	55.5	52.7	26.7	3.3	-38.3	0.0	0.3	47.6	44.8	0	0	47.6	44.8	V		
2.780	3.0	46.4	39.7	29.3	4.2	-37.4	0.0	0.6	43.1	36.3	74	54	-30.9	-17.7	V		
3.708	3.0	43.6	30.3	31.6	4.9	-36.8	0.0	0.6	43.8	30.5	74	54	-30.2	-23.5	V		
4.634	3.0	41.5	28.3	32.9	5.7	-36.5	0.0	0.6	44.1	30.9	74	54	-29.9	-23.1	V		
5.561	3.0	46.2	42.3	34.0	6.3	-36.4	0.0	0.5	50.5	46.6	0	0	50.5	46.6	V		
6.488	3.0	44.3	38.5	34.4	6.8	-36.3	0.0	0.5	49.8	44.0	0	0	49.8	44.0	V		
7.416	3.0	41.4	38.3	35.5	7.3	-36.2	0.0	0.6	48.6	45.5	74	54	-25.4	-8.5	V		
8.341	3.0	40.4	29.6	36.6	7.8	-36.3	0.0	0.7	49.2	38.4	74	54	-24.8	-15.6	V		
9.269	3.0	42.1	33.8	37.3	8.3	-36.8	0.0	0.7	51.6	43.4	0	0	51.6	43.4	V		
1.854	3.0	56.0	54.9	26.7	3.3	-38.3	0.0	0.3	48.1	47.0	0	0	48.1	47.0	H		
2.780	3.0	45.0	37.5	29.3	4.2	-37.4	0.0	0.6	41.7	34.2	74	54	-32.3	-19.8	H		
3.708	3.0	41.7	33.3	31.6	4.9	-36.8	0.0	0.6	41.9	33.5	74	54	-32.1	-20.5	H		
4.635	3.0	40.5	35.1	32.9	5.7	-36.5	0.0	0.6	43.1	37.7	74	54	-30.9	-16.3	H		
5.561	3.0	43.3	39.1	34.0	6.3	-36.4	0.0	0.5	47.6	43.5	0	0	47.6	43.5	H		
6.488	3.0	40.6	33.5	34.4	6.8	-36.3	0.0	0.5	46.1	38.9	0	0	46.1	38.9	H		
7.415	3.0	42.9	33.6	35.5	7.3	-36.2	0.0	0.6	50.1	40.8	74	54	-23.9	-13.2	H		
8.341	3.0	40.4	30.3	36.6	7.8	-36.3	0.0	0.7	49.2	39.1	74	54	-24.8	-14.9	H		
9.269	3.0	41.4	33.0	37.3	8.3	-36.8	0.0	0.7	51.0	42.5	0	0	51.0	42.5	H		
Rev. 07.22.09																	
f	Measurement Frequency					Amp	Preamp Gain					Avg Lim	Average Field Strength Limit				
Dist	Distance to Antenna					D Corr	Distance Correct to 3 meters					Pk Lim	Peak Field Strength Limit				
Read	Analyzer Reading					Avg	Average Field Strength @ 3 m					Avg Mar	Margin vs. Average Limit				
AF	Antenna Factor					Peak	Calculated Peak Field Strength					Pk Mar	Margin vs. Peak Limit				
CL	Cable Loss					HPF	High Pass Filter										

kV2c Meter Radiated Emissions Above 1 GHz

8.1dBi Omni Antenna Data Spread Sheet
0 dBi Puck Antenna Data Spread Sheet
8.5 dBi Panel Antenna Data Spread Sheet

High Frequency Measurement																			
Compliance Certification Services, Fremont 5m Chamber																			
Company:		Silver Spring Networks																	
Project #:		10U13400																	
Date:		10/29/10																	
Test Engineer:		Thanh Nguyen																	
Configuration:		EUT Model KV2C (FCC ID OWS-NIC514) with 8.1dBi Monopole Ant.DC PWR																	
Mode:		Tx normal																	
Test Equipment:																			
Horn 1-18GHz				Pre-amplifer 1-26GHz				Pre-amplifer 26-40GHz				Horn > 18GHz				FCC 15.205			
T60; S/N: 2238 @3m				T34 HP 8449B															
HI Frequency Cables																			
3' cable 22807700				12' cable 22807600				20' cable 22807500				HPF				Reject Filter			
3' cable 22807700				12' cable 22807600				20' cable 22807500				HPF_1.5GHz							
Peak Measurements RBW=VBW=1MHz																			
Average Measurements RBW=1MHz ; VBW=10Hz																			
f GHz	Dist (m)	Read Pk dBuV	Read Avg. dBuV	AF dB/m	CL dB	Amp dB	D Corr dB	Filtr dB	Peak dBuV/m	Avg dBuV/m	Pk Lim dBuV/m	Avg Lim dBuV/m	Pk Mar dB	Avg Mar dB	Notes (V/H)				
Channel 0 , 902.3MHz																			
1.804	3.0	58.4	55.9	27.1	3.3	-37.1	0.0	0.3	52.0	49.5	0	0	52.0	49.5	V				
2.707	3.0	44.3	37.6	28.9	4.1	-36.1	0.0	0.6	41.7	35.0	74	54	-32.3	-19.0	V				
3.609	3.0	41.2	33.3	31.1	4.8	-35.3	0.0	0.6	42.4	34.5	74	54	-31.6	-19.5	V				
4.511	3.0	40.2	30.3	32.4	5.6	-34.9	0.0	0.6	43.9	33.9	74	54	-30.1	-20.1	V				
5.414	3.0	38.7	28.5	33.4	6.2	-34.7	0.0	0.5	44.2	34.0	74	54	-29.8	-20.0	Noise floor				
1.804	3.0	52.2	49.2	27.1	3.3	-37.1	0.0	0.3	45.8	42.8	0	0	45.8	42.8	H				
2.707	3.0	41.9	34.5	28.9	4.1	-36.1	0.0	0.6	39.3	32.0	74	54	-34.7	-22.0	H				
3.609	3.0	39.7	30.1	31.1	4.8	-35.3	0.0	0.6	40.9	31.3	74	54	-33.1	-22.7	H				
4.511	3.0	38.8	26.2	32.4	5.6	-34.9	0.0	0.6	42.5	29.9	74	54	-31.5	-24.1	Noise floor				
Channel 43 , 915.167MHz																			
1.830	3.0	57.8	56.3	27.2	3.3	-37.1	0.0	0.3	51.5	50.0	0	0	51.5	50.0	V				
2.746	3.0	45.1	39.3	29.0	4.1	-36.1	0.0	0.6	42.7	36.9	74	54	-31.3	-17.1	V				
3.661	3.0	39.7	28.6	31.2	4.9	-35.3	0.0	0.6	41.1	30.0	74	54	-32.9	-24.0	V				
4.578	3.0	38.9	28.6	32.5	5.6	-34.9	0.0	0.6	42.7	32.4	74	54	-31.3	-21.6	Noise floor				
1.830	3.0	53.0	50.9	27.2	3.3	-37.1	0.0	0.3	46.7	44.6	0	0	46.7	44.6	H				
2.746	3.0	54.9	52.4	29.0	4.1	-36.1	0.0	0.6	52.5	50.0	74	54	-21.5	-4.0	H				
3.661	3.0	45.1	40.6	31.2	4.9	-35.3	0.0	0.6	46.5	42.0	74	54	-27.5	-12.0	H				
4.576	3.0	40.7	27.6	32.5	5.6	-34.9	0.0	0.6	44.5	31.4	74	54	-29.5	-22.6	Noise floor				
Channel 82 , 926.95MHz																			
1.854	3.0	53.1	50.7	27.3	3.3	-37.1	0.0	0.3	47.0	44.6	0	0	47.0	44.6	V				
2.780	3.0	45.6	41.0	29.1	4.2	-36.1	0.0	0.6	43.3	38.7	74	54	-30.7	-15.3	V				
3.708	3.0	39.5	28.6	31.4	4.9	-35.2	0.0	0.6	41.1	30.2	74	54	-32.9	-23.8	V				
4.634	3.0	38.5	28.2	32.5	5.7	-34.9	0.0	0.6	42.4	32.1	74	54	-31.6	-21.9	V				
5.561	3.0	36.8	25.4	33.6	6.3	-34.8	0.0	0.5	42.3	31.0	0	0	42.3	31.0	Noise floor				
1.854	3.0	55.5	54.1	27.3	3.3	-37.1	0.0	0.3	49.3	48.0	0	0	49.3	48.0	H				
2.780	3.0	45.3	39.8	29.1	4.2	-36.1	0.0	0.6	43.0	37.5	74	54	-31.0	-16.5	H				
3.708	3.0	40.3	28.4	31.4	4.9	-35.2	0.0	0.6	41.9	30.0	74	54	-32.1	-24.0	H				
4.635	3.0	38.6	26.0	32.5	5.7	-34.9	0.0	0.6	42.5	29.9	74	54	-31.5	-24.1	Noise floor				
Rev. 07.22.09																			
f	Measurement Frequency					Amp	Preamp Gain					Avg Lim	Average Field Strength Limit						
Dist	Distance to Antenna					D Corr	Distance Correct to 3 meters					Pk Lim	Peak Field Strength Limit						
Read	Analyzer Reading					Avg	Average Field Strength @ 3 m					Avg Mar	Margin vs. Average Limit						
AF	Antenna Factor					Peak	Calculated Peak Field Strength					Pk Mar	Margin vs. Peak Limit						
CL	Cable Loss					HPF	High Pass Filter												

High Frequency Measurement																	
Compliance Certification Services, Fremont 5m Chamber																	
Company:		Silver Spring Networks															
Project #:		10U13400															
Date:		10/26/10															
Test Engineer:		Thanh Nguyen															
Configuration:		EUT Model KV2C, NIC 314K (FCC ID OWS-NIC514) with Puck Antenna, HP DC PWR															
Mode:		Tx Max power															
Test Equipment:																	
Horn 1-18GHz		Pre-amplifier 1-26GHz			Pre-amplifier 26-40GHz			Horn > 18GHz									
T73; S/N: 6717 @3m		T144 Miteq 3008A00931											FCC 15.205				
HI Frequency Cables																	
3' cable 22807700		12' cable 22807600			20' cable 22807500			HPF		Reject Filter		Peak Measurements RBW=VBW=1MHz Average Measurements RBW=1MHz ; VBW=10Hz					
3' cable 22807700		12' cable 22807600			20' cable 22807500			HPF_1.5GHz									
f GHz	Dist (m)	Read Pk dBuV	Read Avg. dBuV	AF dB/m	CL dB	Amp dB	D Corr dB	Filtr dB	Peak dBuV/m	Avg dBuV/m	Pk Lim dBuV/m	Avg Lim dBuV/m	Pk Mar dB	Avg Mar dB	Notes (V/H)		
Channel 0 , 902.3MHz																	
1.804	3.0	54.7	52.5	26.6	3.3	-38.3	0.0	0.3	46.4	44.3	0	0	46.4	44.3	V		
2.707	3.0	49.9	45.8	30.3	4.1	-37.4	0.0	0.6	47.3	43.3	74	54	-26.7	-10.7	V		
3.609	3.0	41.9	29.3	31.4	4.8	-36.9	0.0	0.6	41.8	29.2	74	54	-32.2	-24.8	V		
4.511	3.0	43.0	35.3	32.7	5.6	-36.5	0.0	0.6	45.4	37.7	74	54	-28.6	-16.3	V		
5.414	3.0	40.1	29.1	33.8	6.2	-36.3	0.0	0.5	44.4	33.3	74	54	-29.6	-20.7	V		
6.316	3.0	45.3	41.0	34.3	6.7	-36.3	0.0	0.5	50.5	46.2	0	0	50.5	46.2	V		
7.218	3.0	41.0	28.5	35.2	7.2	-36.2	0.0	0.6	47.8	35.2	0	0	47.8	35.2	V		
8.120	3.0	42.3	33.1	36.4	7.7	-36.2	0.0	0.7	50.9	41.7	74	54	-23.1	-12.3	V		
9.023	3.0	39.8	27.6	37.2	8.2	-36.7	0.0	0.7	49.3	37.1	74	54	-24.7	-16.9	V		
1.804	3.0	58.3	57.0	26.6	3.3	-38.3	0.0	0.3	50.1	48.8	0	0	50.1	48.8	H		
2.707	3.0	50.0	47.8	29.1	4.1	-37.4	0.0	0.6	47.3	44.2	74	54	-26.7	-9.8	H		
3.609	3.0	42.1	29.6	31.4	4.8	-36.9	0.0	0.6	42.0	29.5	74	54	-32.0	-24.5	H		
4.511	3.0	41.2	30.4	32.7	5.6	-36.5	0.0	0.6	43.6	32.7	74	54	-30.4	-21.3	H		
5.414	3.0	39.5	28.8	33.8	6.2	-36.3	0.0	0.5	43.8	33.1	74	54	-30.2	-20.9	H		
6.316	3.0	40.1	29.7	34.3	6.7	-36.3	0.0	0.5	45.3	34.9	0	0	45.3	34.9	H		
7.218	3.0	40.6	27.9	35.2	7.2	-36.2	0.0	0.6	47.4	34.6	0	0	47.4	34.6	H		
8.120	3.0	46.5	41.3	36.4	7.7	-36.2	0.0	0.7	55.1	49.9	74	54	-18.9	-4.1	H		
9.023	3.0	39.8	28.4	37.2	8.2	-36.7	0.0	0.7	49.2	37.8	74	54	-24.8	-16.2	H		
Channel 43 , 915.167MHz																	
1.830	3.0	53.6	49.5	26.6	3.3	-38.3	0.0	0.3	45.5	41.4	0	0	45.5	41.4	V		
2.746	3.0	49.5	45.8	29.2	4.1	-37.4	0.0	0.6	46.0	42.3	74	54	-28.0	-11.7	V		
3.661	3.0	42.5	30.6	31.5	4.9	-36.9	0.0	0.6	42.6	30.7	74	54	-31.4	-23.3	V		
4.578	3.0	42.6	35.0	32.8	5.6	-36.5	0.0	0.6	45.1	37.4	74	54	-28.9	-16.6	V		
5.491	3.0	41.7	33.4	33.9	6.2	-36.4	0.0	0.5	46.0	37.7	0	0	46.0	37.7	V		
6.407	3.0	40.0	29.7	34.3	6.8	-36.3	0.0	0.5	45.3	35.0	0	0	45.3	35.0	V		
7.322	3.0	40.7	28.0	35.3	7.3	-36.2	0.0	0.6	47.7	35.0	74	54	-26.3	-19.0	V		
8.237	3.0	42.9	31.6	36.5	7.8	-36.3	0.0	0.7	51.6	40.3	74	54	-22.4	-13.7	V		
9.152	3.0	40.2	29.5	37.2	8.3	-36.7	0.0	0.7	49.7	39.0	74	54	-24.3	-15.0	V		
1.830	3.0	59.5	58.2	26.6	3.3	-38.3	0.0	0.3	51.5	50.2	0	0	51.5	50.2	H		
2.746	3.0	48.9	45.7	29.2	4.1	-37.4	0.0	0.6	45.4	42.2	74	54	-28.6	-11.8	H		
3.661	3.0	41.3	30.5	31.5	4.9	-36.9	0.0	0.6	41.4	30.6	74	54	-32.6	-23.4	H		
4.576	3.0	41.0	30.6	32.8	5.6	-36.5	0.0	0.6	43.5	33.1	74	54	-30.5	-20.9	H		
5.491	3.0	39.5	27.3	33.9	6.2	-36.4	0.0	0.5	43.9	31.7	0	0	43.9	31.7	H		
6.406	3.0	41.1	32.8	34.3	6.8	-36.3	0.0	0.5	46.4	38.2	0	0	46.4	38.2	H		
7.322	3.0	40.5	28.0	35.3	7.3	-36.2	0.0	0.6	47.5	35.0	74	54	-26.5	-19.0	H		
8.238	3.0	40.9	27.7	36.5	7.8	-36.3	0.0	0.7	49.6	36.4	74	54	-24.4	-17.6	H		
Channel 82 , 926.95MHz																	
1.854	3.0	52.1	48.0	26.7	3.3	-38.3	0.0	0.3	44.2	40.1	0	0	44.2	40.1	V		
2.780	3.0	50.5	46.5	29.3	4.2	-37.4	0.0	0.6	47.2	43.1	74	54	-26.8	-10.9	V		
3.708	3.0	41.3	29.2	31.6	4.9	-36.8	0.0	0.6	41.6	29.5	74	54	-32.4	-24.5	V		
4.634	3.0	42.0	33.9	32.9	5.7	-36.5	0.0	0.6	44.6	36.4	74	54	-29.4	-17.6	V		
5.561	3.0	43.2	36.2	34.0	6.3	-36.4	0.0	0.5	47.6	40.6	0	0	47.6	40.6	V		
6.488	3.0	39.9	28.5	34.4	6.8	-36.3	0.0	0.5	45.3	33.9	0	0	45.3	33.9	V		
7.416	3.0	40.4	28.3	35.5	7.3	-36.2	0.0	0.6	47.6	35.5	74	54	-26.4	-18.5	V		
8.341	3.0	40.6	29.0	36.6	7.8	-36.3	0.0	0.7	49.4	37.8	74	54	-24.6	-16.2	V		
9.269	3.0	40.1	28.0	37.3	8.3	-36.8	0.0	0.7	49.6	37.5	0	0	49.6	37.5	Noise floor		
1.854	3.0	61.5	59.0	26.7	3.3	-38.3	0.0	0.3	53.6	51.1	0	0	53.6	51.1	H		
2.780	3.0	49.8	45.7	29.3	4.2	-37.4	0.0	0.6	46.4	42.4	74	54	-27.6	-11.6	H		
3.708	3.0	41.9	31.6	31.6	4.9	-36.8	0.0	0.6	42.2	31.9	74	54	-31.8	-22.1	H		
4.635	3.0	41.5	31.2	32.9	5.7	-36.5	0.0	0.6	44.1	33.7	74	54	-29.9	-20.3	H		
5.561	3.0	41.6	34.3	34.0	6.3	-36.4	0.0	0.5	46.0	38.7	0	0	46.0	38.7	H		
6.488	3.0	40.3	30.5	34.4	6.8	-36.3	0.0	0.5	45.7	36.0	0	0	45.7	36.0	H		
7.415	3.0	40.8	27.8	35.5	7.3	-36.2	0.0	0.6	48.0	35.0	74	54	-26.0	-19.0	H		
8.341	3.0	40.0	27.6	36.6	7.8	-36.3	0.0	0.7	48.8	36.4	74	54	-25.2	-17.6	H		
9.269	3.0	39.7	28.3	37.3	8.3	-36.8	0.0	0.7	49.2	37.9	0	0	49.2	37.9	Noise floor		
Rev. 07.22.09																	
f	Measurement Frequency					Amp	Preamp Gain					Avg Lim	Average Field Strength Limit				
Dist	Distance to Antenna					D Corr	Distance Correct to 3 meters					Pk Lim	Peak Field Strength Limit				
Read	Analyzer Reading					Avg	Average Field Strength @ 3 m					Avg Mar	Margin vs. Average Limit				
AF	Antenna Factor					Peak	Calculated Peak Field Strength					Pk Mar	Margin vs. Peak Limit				
CL	Cable Loss					HPF	High Pass Filter										

High Frequency Measurement																
Compliance Certification Services, Fremont 5m Chamber																
Company:		Silver Spring Networks														
Project #:		10U13400														
Date:		10/26/10														
Test Engineer:		Thanh Nguyen														
Configuration:		EUT Model KV2C, NIC 314K (FCC ID OWS-NIC514) with Panel Antenna, HP DC PWR														
Mode:		Tx Max power														
Test Equipment:																
Horn 1-18GHz		Pre-amplifier 1-26GHz			Pre-amplifier 26-40GHz			Horn > 18GHz								
T73; S/N: 6717 @3m		T144 Miteq 3008A00931														
Hi Frequency Cables																
3' cable 22807700		12' cable 22807600			20' cable 22807500			HPF		Reject Filter		Peak Measurements				
3' cable 22807700		12' cable 22807600			20' cable 22807500			HPF_1.5GHz				RBW=VBW=1MHz				
Average Measurements																
RBW=1MHz ; VBW=10Hz																
f GHz	Dist (m)	Read Pk dBuV	Read Avg. dBuV	AF dB/m	CL dB	Amp dB	D Corr dB	Filtr dB	Peak dBuV/m	Avg dBuV/m	Pk Lim dBuV/m	Avg Lim dBuV/m	Pk Mar dB	Avg Mar dB	Notes (V/H)	
Channel 0 , 902.3MHz																
1.804	3.0	59.2	57.6	26.6	3.3	-38.3	0.0	0.3	51.0	49.4	0	0	51.0	49.4	V	
2.707	3.0	49.9	45.0	30.3	4.1	-37.4	0.0	0.6	47.4	42.5	74	54	-26.6	-11.5	V	
3.609	3.0	41.9	30.3	31.4	4.8	-36.9	0.0	0.6	41.8	30.2	74	54	-32.2	-23.8	V	
4.511	3.0	43.7	37.7	32.7	5.6	-36.5	0.0	0.6	46.0	40.1	74	54	-28.0	-13.9	V	
5.414	3.0	41.7	31.6	33.8	6.2	-36.3	0.0	0.5	45.9	35.9	74	54	-28.1	-18.1	V	
6.316	3.0	47.5	43.8	34.3	6.7	-36.3	0.0	0.5	52.7	49.0	0	0	52.7	49.0	V	
7.218	3.0	41.7	31.9	35.2	7.2	-36.2	0.0	0.6	48.4	38.6	0	0	48.4	38.6	V	
8.120	3.0	48.4	43.7	36.4	7.7	-36.2	0.0	0.7	57.0	52.3	74	54	-17.0	-1.7	V	
9.023	3.0	42.5	32.4	37.2	8.2	-36.7	0.0	0.7	52.0	41.9	74	54	-22.0	-12.1	V	
1.804	3.0	56.9	55.8	26.6	3.3	-38.3	0.0	0.3	48.7	47.6	0	0	48.7	47.6	H	
2.707	3.0	50.3	46.5	29.1	4.1	-37.4	0.0	0.6	46.6	42.9	74	54	-27.4	-11.1	H	
3.609	3.0	42.0	30.1	31.4	4.8	-36.9	0.0	0.6	41.9	30.0	74	54	-32.1	-24.0	H	
4.511	3.0	41.9	31.8	32.7	5.6	-36.5	0.0	0.6	44.2	34.2	74	54	-29.8	-19.8	H	
5.414	3.0	43.2	34.2	33.8	6.2	-36.3	0.0	0.5	47.4	38.4	74	54	-26.6	-15.6	H	
6.316	3.0	48.3	44.6	34.3	6.7	-36.3	0.0	0.5	53.5	49.8	0	0	53.5	49.8	H	
7.218	3.0	42.1	32.5	35.2	7.2	-36.2	0.0	0.6	48.9	39.3	0	0	48.9	39.3	H	
8.120	3.0	48.9	44.4	36.4	7.7	-36.2	0.0	0.7	57.5	53.0	74	54	-16.5	-1.0	H	
9.023	3.0	43.0	33.9	37.2	8.2	-36.7	0.0	0.7	52.4	43.3	74	54	-21.6	-10.7	H	
Channel 43 , 915.167MHz																
1.830	3.0	59.2	57.9	26.6	3.3	-38.3	0.0	0.3	51.1	49.8	0	0	51.1	49.8	V	
2.746	3.0	50.3	46.9	29.2	4.1	-37.4	0.0	0.6	46.8	43.4	74	54	-27.2	-10.6	V	
3.661	3.0	41.5	29.0	31.5	4.9	-36.9	0.0	0.6	41.6	29.1	74	54	-32.4	-24.9	V	
4.578	3.0	42.1	32.2	32.8	5.6	-36.5	0.0	0.6	44.6	34.7	74	54	-29.4	-19.3	V	
5.491	3.0	40.9	31.2	33.9	6.2	-36.4	0.0	0.5	45.2	35.6	0	0	45.2	35.6	V	
6.407	3.0	43.7	36.8	34.3	6.8	-36.3	0.0	0.5	49.1	42.1	0	0	49.1	42.1	V	
7.322	3.0	41.2	28.2	35.3	7.3	-36.2	0.0	0.6	48.2	35.2	74	54	-25.8	-18.8	V	
8.237	3.0	41.8	32.3	36.5	7.8	-36.3	0.0	0.7	50.5	41.1	74	54	-23.5	-12.9	V	
9.152	3.0	41.2	29.7	37.2	8.3	-36.7	0.0	0.7	50.7	39.2	74	54	-23.3	-14.8	V	
1.830	3.0	59.7	58.3	26.6	3.3	-38.3	0.0	0.3	51.6	50.3	0	0	51.6	50.3	H	
2.746	3.0	51.4	48.2	29.2	4.1	-37.4	0.0	0.6	48.0	44.7	74	54	-26.0	-9.3	H	
3.661	3.0	41.6	29.8	31.5	4.9	-36.9	0.0	0.6	41.7	29.9	74	54	-32.3	-24.1	H	
4.576	3.0	40.6	28.8	32.8	5.6	-36.5	0.0	0.6	43.1	31.3	74	54	-30.9	-22.7	H	
5.491	3.0	40.1	29.2	33.9	6.2	-36.4	0.0	0.5	44.4	33.5	0	0	44.4	33.5	H	
6.406	3.0	40.2	28.9	34.3	6.8	-36.3	0.0	0.5	45.6	34.3	0	0	45.6	34.3	H	
7.322	3.0	40.6	28.4	35.3	7.3	-36.2	0.0	0.6	47.6	35.4	74	54	-26.4	-18.6	H	
8.238	3.0	43.7	35.3	36.5	7.8	-36.3	0.0	0.7	52.4	44.0	74	54	-21.6	-10.0	H	
Channel 82 , 926.95MHz																
1.854	3.0	56.8	53.6	26.7	3.3	-38.3	0.0	0.3	48.9	45.7	0	0	48.9	45.7	V	
2.780	3.0	50.5	45.9	29.3	4.2	-37.4	0.0	0.6	47.1	42.6	74	54	-26.9	-11.4	V	
3.708	3.0	42.4	30.6	31.6	4.9	-36.8	0.0	0.6	42.6	30.8	74	54	-31.4	-23.2	V	
4.634	3.0	43.6	33.9	32.9	5.7	-36.5	0.0	0.6	46.2	36.5	74	54	-27.8	-17.5	V	
5.561	3.0	43.0	36.2	34.0	6.3	-36.4	0.0	0.5	47.4	40.5	0	0	47.4	40.5	V	
6.488	3.0	44.5	38.7	34.4	6.8	-36.3	0.0	0.5	50.0	44.2	0	0	50.0	44.2	V	
7.416	3.0	40.2	27.8	35.5	7.3	-36.2	0.0	0.6	47.4	35.0	74	54	-26.6	-19.0	V	
8.341	3.0	40.1	28.0	36.6	7.8	-36.3	0.0	0.7	49.0	36.9	74	54	-25.0	-17.1	V	
9.269	3.0	39.5	27.1	37.3	8.3	-36.8	0.0	0.7	49.1	36.7	0	0	49.1	36.7	Noise floor	
1.854	3.0	56.0	53.8	26.7	3.3	-38.3	0.0	0.3	48.1	45.9	0	0	48.1	45.9	H	
2.780	3.0	51.3	45.6	29.3	4.2	-37.4	0.0	0.6	47.9	42.3	74	54	-26.1	-11.7	H	
3.708	3.0	41.9	29.5	31.6	4.9	-36.8	0.0	0.6	42.1	29.8	74	54	-31.9	-24.2	H	
4.635	3.0	40.8	29.3	32.9	5.7	-36.5	0.0	0.6	43.4	31.9	74	54	-30.6	-22.1	H	
5.561	3.0	42.5	33.6	34.0	6.3	-36.4	0.0	0.5	46.8	38.0	0	0	46.8	38.0	H	
6.488	3.0	41.4	30.8	34.4	6.8	-36.3	0.0	0.5	46.9	36.3	0	0	46.9	36.3	H	
7.415	3.0	40.1	28.2	35.5	7.3	-36.2	0.0	0.6	47.3	35.4	74	54	-26.7	-18.6	H	
8.341	3.0	41.7	30.1	36.6	7.8	-36.3	0.0	0.7	50.5	38.9	74	54	-23.5	-15.1	H	
9.269	3.0	39.5	27.3	37.3	8.3	-36.8	0.0	0.7	49.1	36.9	0	0	49.1	36.9	Noise floor	
Rev. 07.22.09																
f	Measurement Frequency					Amp	Preamp Gain					Avg Lim	Average Field Strength Limit			
Dist	Distance to Antenna					D Corr	Distance Correct to 3 meters					Pk Lim	Peak Field Strength Limit			
Read	Analyzer Reading					Avg	Average Field Strength @ 3 m					Avg Mar	Margin vs. Average Limit			
AF	Antenna Factor					Peak	Calculated Peak Field Strength					Pk Mar	Margin vs. Peak Limit			
CL	Cable Loss					HPF	High Pass Filter									

S4e Meter Radiated Emissions Above 1 GHz

8.1dBi Omni Antenna Data Spread Sheet
0 dBi Puck Antenna Data Spread Sheet
8.5 dBi Panel Antenna Data Spread Sheet

High Frequency Measurement																	
Compliance Certification Services, Fremont 5m Chamber																	
Company:		Silver Spring Networks															
Project #:		10U13400															
Date:		10/18/10															
Test Engineer:		Thanh Nguyen															
Configuration:		EUT Model NIC314K with MPACK 8.1 dBi Omni, DC PWR Supply, Remote Support Laptop															
Mode:		Tx normal															
Test Equipment:																	
Horn 1-18GHz				Pre-amplifier 1-26GHz				Pre-amplifier 26-40GHz				Horn > 18GHz				FCC 15.205	
T60; S/N: 2238 @3m				T34 HP 8449B													
HI Frequency Cables																	
3' cable 22807700				12' cable 22807600				20' cable 22807500				HPF				Reject Filter	
3' cable 22807700				12' cable 22807600				20' cable 22807500				HPF_1.5GHz					
Peak Measurements RBW=VBW=1MHz Average Measurements RBW=1MHz ; VBW=10Hz																	
f GHz	Dist (m)	Read Pk dBuV	Read Avg. dBuV	AF dB/m	CL dB	Amp dB	D Corr dB	Filtr dB	Peak dBuV/m	Avg dBuV/m	Pk Lim dBuV/m	Avg Lim dBuV/m	Pk Mar dB	Avg Mar dB	Notes (V/H)		
Channel 0, 902.3MHz																	
2.707	3.0	50.7	42.7	28.9	4.1	-36.1	0.0	0.6	48.1	40.1	74	54	-25.9	-13.9	V		
3.609	3.0	41.1	30.3	31.1	4.8	-35.3	0.0	0.6	42.3	31.5	74	54	-31.7	-22.5	V		
4.511	3.0	40.9	33.2	32.4	5.6	-34.9	0.0	0.6	44.6	36.9	74	54	-29.4	-17.1	V		
5.414	3.0	41.1	34.2	33.4	6.2	-34.7	0.0	0.5	46.6	39.6	74	54	-27.4	-14.4	V		
8.120	3.0	45.1	40.8	36.4	7.7	-34.0	0.0	0.7	55.9	51.6	74	54	-18.1	-2.4	V		
9.023	3.0	40.9	33.1	37.4	8.2	-35.2	0.0	0.7	52.0	44.2	74	54	-22.0	-9.8	V		
2.707	3.0	48.7	43.3	28.9	4.1	-36.1	0.0	0.6	46.1	40.8	74	54	-27.9	-13.2	H		
3.609	3.0	41.7	32.2	31.1	4.8	-35.3	0.0	0.6	42.9	33.4	74	54	-31.1	-20.6	H		
4.511	3.0	40.3	32.8	32.4	5.6	-34.9	0.0	0.6	44.0	36.5	74	54	-30.0	-17.5	H		
5.414	3.0	40.1	32.0	33.4	6.2	-34.7	0.0	0.5	45.5	37.5	74	54	-28.5	-16.5	H		
8.120	3.0	38.9	31.2	36.4	7.7	-34.0	0.0	0.7	49.7	41.9	74	54	-24.3	-12.1	H		
9.023	3.0	38.0	30.3	37.4	8.2	-35.2	0.0	0.7	49.2	41.4	74	54	-24.8	-12.6	H		
Channel 43, 915.21MHz																	
2.746	3.0	55.7	52.0	29.0	4.1	-36.1	0.0	0.6	53.3	49.6	74	54	-20.7	-4.4	V		
3.661	3.0	44.2	32.6	31.2	4.9	-35.3	0.0	0.6	45.6	34.0	74	54	-28.4	-20.0	V		
4.576	3.0	40.5	33.7	32.5	5.6	-34.9	0.0	0.6	44.3	37.4	74	54	-29.7	-16.6	V		
7.322	3.0	39.9	31.3	35.5	7.3	-34.1	0.0	0.6	49.2	40.5	74	54	-24.8	-13.5	V		
8.237	3.0	38.8	31.6	36.5	7.8	-34.2	0.0	0.7	49.6	42.4	74	54	-24.4	-11.6	V		
9.152	3.0	37.8	29.7	37.4	8.3	-34.9	0.0	0.7	49.3	41.2	74	54	-24.7	-12.8	V		
2.745	3.0	56.8	52.5	29.0	4.1	-36.1	0.0	0.6	54.4	50.1	74	54	-19.6	-3.9	H		
3.661	3.0	43.2	32.8	31.2	4.9	-35.3	0.0	0.6	44.7	34.2	74	54	-29.3	-19.8	H		
4.576	3.0	43.3	34.7	32.5	5.6	-34.9	0.0	0.6	47.1	38.5	74	54	-26.9	-15.5	H		
7.322	3.0	37.4	28.4	35.5	7.3	-34.1	0.0	0.6	46.7	37.6	74	54	-27.3	-16.4	H		
8.238	3.0	41.3	32.2	36.5	7.8	-34.2	0.0	0.7	52.1	43.0	74	54	-21.9	-11.0	H		
9.153	3.0	38.6	29.3	37.4	8.3	-34.9	0.0	0.7	50.1	40.9	74	54	-23.9	-13.1	H		
Channel 82, 926.85MHz																	
2.780	3.0	51.9	47.8	29.1	4.2	-36.1	0.0	0.6	49.6	45.5	74	54	-24.4	-8.5	V		
3.708	3.0	41.4	30.3	31.4	4.9	-35.2	0.0	0.6	43.0	31.9	74	54	-31.0	-22.1	V		
4.634	3.0	42.5	34.6	32.5	5.7	-34.9	0.0	0.6	46.4	38.5	74	54	-27.6	-15.5	V		
8.341	3.0	36.2	28.2	36.6	7.8	-34.3	0.0	0.7	47.0	39.1	74	54	-27.0	-14.9	V		
2.780	3.0	46.6	40.3	29.1	4.2	-36.1	0.0	0.6	44.3	38.0	74	54	-29.7	-16.0	H		
3.708	3.0	42.6	33.3	31.4	4.9	-35.2	0.0	0.6	44.2	34.9	74	54	-29.8	-19.1	H		
4.635	3.0	40.3	30.0	32.5	5.7	-34.9	0.0	0.6	44.2	33.9	74	54	-29.8	-20.1	H		
7.415	3.0	37.4	28.4	35.6	7.3	-34.1	0.0	0.6	46.9	37.9	74	54	-27.1	-16.1	H		
8.341	3.0	37.3	28.2	36.6	7.8	-34.3	0.0	0.7	48.2	39.1	74	54	-25.8	-14.9	H		
Rev. 07.22.09																	
f	Measurement Frequency					Amp	Preamp Gain					Avg Lim	Average Field Strength Limit				
Dist	Distance to Antenna					D Corr	Distance Correct to 3 meters					Pk Lim	Peak Field Strength Limit				
Read	Analyzer Reading					Avg	Average Field Strength @ 3 m					Avg Mar	Margin vs. Average Limit				
AF	Antenna Factor					Peak	Calculated Peak Field Strength					Pk Mar	Margin vs. Peak Limit				
CL	Cable Loss					HPF	High Pass Filter										

High Frequency Measurement																	
Compliance Certification Services, Fremont 5m Chamber																	
Company:		Silver Spring Networks															
Project #:		10U13400															
Date:		10/18/10															
Test Engineer:		Thanh Nguyen															
Configuration:		EUT Model NIC314K with Puck 3 dBi Antenna DC PWR Supply, Remote Support Laptop															
Mode:		Tx normal															
Test Equipment:																	
Horn 1-18GHz				Pre-amplifier 1-26GHz				Pre-amplifier 26-40GHz				Horn > 18GHz				FCC 15.205	
T60; S/N: 2238 @3m				T34 HP 8449B													
Hi Frequency Cables																	
3' cable 22807700				12' cable 22807600				20' cable 22807500				HPF		Reject Filter		Peak Measurements RBW=VBW=1MHz	
3' cable 22807700				12' cable 22807600				20' cable 22807500				HPF_1.5GHz				Average Measurements RBW=1MHz ; VBW=10Hz	
f GHz	Dist (m)	Read Pk dBuV	Read Avg. dBuV	AF dB/m	CL dB	Amp dB	D Corr dB	Filtr dB	Peak dBuV/m	Avg dBuV/m	Pk Lim dBuV/m	Avg Lim dBuV/m	Pk Mar dB	Avg Mar dB	Notes (V/H)		
Channel 0 , 902.3MHz																	
2.707	3.0	54.0	51.0	28.9	4.1	-36.1	0.0	0.6	51.4	48.4	74	54	-22.6	-5.6	V		
3.609	3.0	46.8	35.4	31.1	4.8	-35.3	0.0	0.6	48.0	36.6	74	54	-26.0	-17.4	V		
4.512	3.0	45.5	34.3	32.4	5.6	-34.9	0.0	0.6	49.2	38.0	74	54	-24.8	-16.0	V		
2.707	3.0	56.4	52.1	28.9	4.1	-36.1	0.0	0.6	53.8	49.5	74	54	-20.2	-4.5	H		
3.609	3.0	46.3	36.2	31.1	4.8	-35.3	0.0	0.6	47.5	37.4	74	54	-26.5	-16.6	H		
4.511	3.0	42.5	32.8	32.4	5.6	-34.9	0.0	0.6	46.2	36.5	74	54	-27.8	-17.5	Noise floor		
Channel 43 , 916.560MHz																	
2.746	3.0	50.8	46.5	29.0	4.1	-36.1	0.0	0.6	48.4	44.1	74	54	-25.6	-9.9	V		
3.661	3.0	40.6	35.7	31.2	4.9	-35.3	0.0	0.6	42.0	37.2	74	54	-32.0	-16.8	V		
4.576	3.0	45.1	34.3	32.5	5.6	-34.9	0.0	0.6	48.9	38.1	74	54	-25.1	-15.9	Noise floor		
2.746	3.0	51.7	44.2	29.0	4.1	-36.1	0.0	0.6	49.3	41.8	74	54	-24.7	-12.2	H		
3.661	3.0	46.0	36.0	31.2	4.9	-35.3	0.0	0.6	47.4	37.4	74	54	-26.6	-16.6	Noise floor		
Channel 82 , 926.85MHz																	
2.781	3.0	52.4	44.9	29.1	4.2	-36.1	0.0	0.6	50.1	42.6	74	54	-23.9	-11.4	V		
3.708	3.0	46.7	35.6	31.4	4.9	-35.2	0.0	0.6	48.4	37.2	74	54	-25.6	-16.8	Noise floor		
2.781	3.0	49.8	43.9	29.1	4.2	-36.1	0.0	0.6	47.6	41.6	74	54	-26.4	-12.4	H		
3.708	3.0	46.0	35.4	31.4	4.9	-35.2	0.0	0.6	47.6	37.0	74	54	-26.4	-17.0	Noise floor		
Rev. 07.22.09																	
f	Measurement Frequency					Amp	Preamp Gain					Avg Lim	Average Field Strength Limit				
Dist	Distance to Antenna					D Corr	Distance Correct to 3 meters					Pk Lim	Peak Field Strength Limit				
Read	Analyzer Reading					Avg	Average Field Strength @ 3 m					Avg Mar	Margin vs. Average Limit				
AF	Antenna Factor					Peak	Calculated Peak Field Strength					Pk Mar	Margin vs. Peak Limit				
CL	Cable Loss					HPF	High Pass Filter										

High Frequency Measurement																	
Compliance Certification Services, Fremont 5m Chamber																	
Company:		Silver Spring Networks															
Project #:		10U13400															
Date:		10/18/10															
Test Engineer:		Thanh Nguyen															
Configuration:		EUT Model NIC314K with Panel 8.5 dBi Circular Antenna, DC PWR Supply, Remote Support Laptop															
Mode:		Tx normal															
Test Equipment:																	
Horn 1-18GHz				Pre-amplifier 1-26GHz				Pre-amplifier 26-40GHz				Horn > 18GHz				FCC 15.205	
T60; S/N: 2238 @3m				T34 HP 8449B													
Hi Frequency Cables																	
3' cable 22807700				12' cable 22807600				20' cable 22807500				HPF		Reject Filter		<u>Peak Measurements</u> RBW=VBW=1MHz <u>Average Measurements</u> RBW=1MHz ; VBW=10Hz	
3' cable 22807700				12' cable 22807600				20' cable 22807500				HPF_1.5GHz					
f GHz	Dist (m)	Read Pk dBuV	Read Avg. dBuV	AF dB/m	CL dB	Amp dB	D Corr dB	Fltr dB	Peak dBuV/m	Avg dBuV/m	Pk Lim dBuV/m	Avg Lim dBuV/m	Pk Mar dB	Avg Mar dB	Notes (V/H)		
Channel 0 , 902.3MHz																	
1.805	3.0	70.7	66.8	27.2	3.3	-37.1	0.0	0.3	64.2	60.4	0	0	64.2	60.4	V		
2.707	3.0	55.1	45.7	28.9	4.1	-36.1	0.0	0.6	52.5	43.1	74	54	-21.5	-10.9	V		
3.609	3.0	45.9	35.9	31.1	4.8	-35.3	0.0	0.6	47.1	37.1	74	54	-26.9	-16.9	V		
4.512	3.0	44.4	35.2	32.4	5.6	-34.9	0.0	0.6	48.1	38.8	74	54	-25.9	-15.2	V		
2.707	3.0	53.9	44.1	28.9	4.1	-36.1	0.0	0.6	51.4	41.5	74	54	-22.6	-12.5	H		
3.607	3.0	44.8	36.0	31.1	4.8	-35.3	0.0	0.6	46.0	37.2	74	54	-28.0	-16.8	H		
4.511	3.0	44.8	33.9	32.4	5.6	-34.9	0.0	0.6	48.5	37.5	74	54	-25.5	-16.5	Noise Floor		
Channel 43 , 916.560MHz																	
1.831	3.0	71.8	66.3	27.2	3.3	-37.1	0.0	0.3	65.5	60.0	0	0	65.5	60.0	V		
2.746	3.0	53.7	45.1	29.0	4.1	-36.1	0.0	0.6	51.3	42.7	74	54	-22.7	-11.3	V		
3.661	3.0	47.0	35.8	31.2	4.9	-35.3	0.0	0.6	48.5	37.2	74	54	-25.5	-16.8	Noise floor		
4.576	3.0	45.1	34.3	32.5	5.6	-34.9	0.0	0.6	48.9	38.1	74	54	-25.1	-15.9	Noise floor		
1.831	3.0	69.3	62.6	27.2	3.3	-37.1	0.0	0.3	63.0	56.4	0	0	63.0	56.4	H		
2.746	3.0	57.6	51.8	29.0	4.1	-36.1	0.0	0.6	55.2	49.4	74	54	-18.8	-4.6	H		
3.661	3.0	48.0	36.4	31.2	4.9	-35.3	0.0	0.6	49.4	37.8	74	54	-24.6	-16.2	Noise floor		
Channel 82 , 926.85MHz																	
1.854	3.0	72.2	70.2	27.3	3.3	-37.1	0.0	0.3	66.1	64.1	0	0	66.1	64.1	V		
2.781	3.0	52.7	45.2	29.1	4.2	-36.1	0.0	0.6	50.4	43.0	74	54	-23.6	-11.0	V		
3.708	3.0	45.0	35.7	31.4	4.9	-35.2	0.0	0.6	46.6	37.3	74	54	-27.4	-16.7	Noise floor		
1.854	3.0	69.7	65.8	27.3	3.3	-37.1	0.0	0.3	63.5	59.7	0	0	63.5	59.7	V		
2.781	3.0	49.8	43.9	29.1	4.2	-36.1	0.0	0.6	47.6	41.6	74	54	-26.4	-12.4	H		
3.708	3.0	46.0	35.4	31.4	4.9	-35.2	0.0	0.6	47.6	37.0	74	54	-26.4	-17.0	Noise floor		
Rev. 07.22.09																	
f	Measurement Frequency					Amp	Preamp Gain					Avg Lim	Average Field Strength Limit				
Dist	Distance to Antenna					D Corr	Distance Correct to 3 meters					Pk Lim	Peak Field Strength Limit				
Read	Analyzer Reading					Avg	Average Field Strength @ 3 m					Avg Mar	Margin vs. Average Limit				
AF	Antenna Factor					Peak	Calculated Peak Field Strength					Pk Mar	Margin vs. Peak Limit				
CL	Cable Loss					HPF	High Pass Filter										

Radiated Emissions Below 1 GHz

All emissions for all antenna and meter combinations were more than 20 dB below 15.205 limits in the 30-1000 MHz frequency range.

Antenna Port Conducted Receiver Spurious Emissions

Emissions for all antenna/meter combinations were almost identical. Worst-case emissions appeared to be for the S4e meter, which also has the lowest coupling loss.

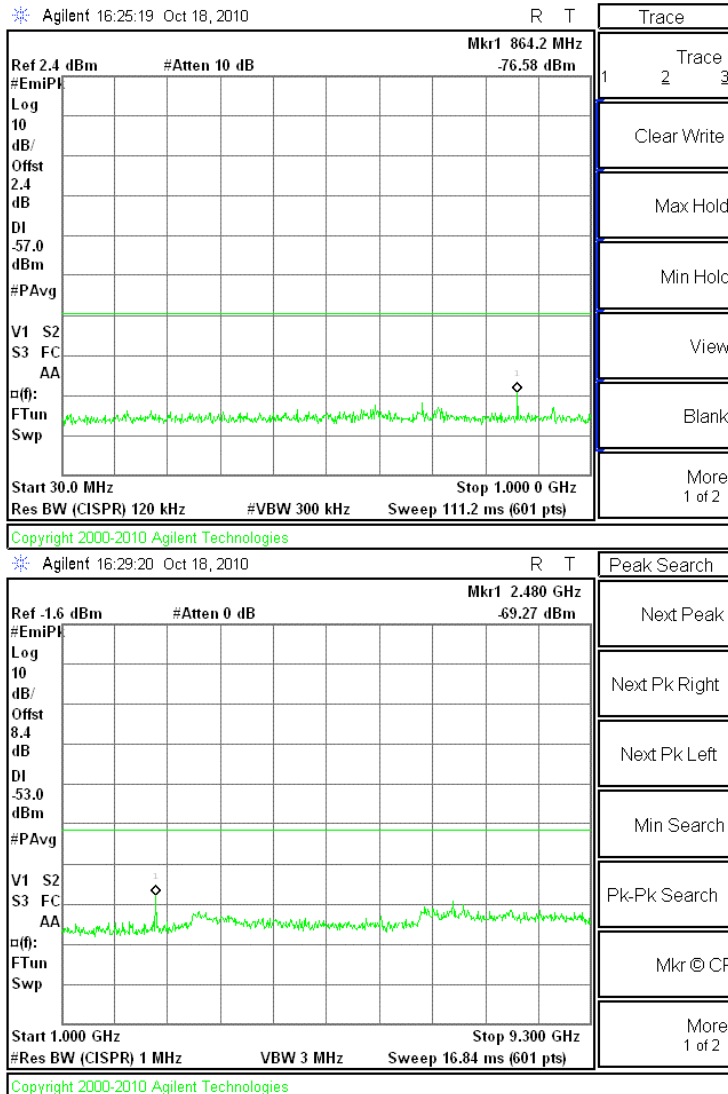

SETUP PHOTOS

RADIATED RF MEASUREMENT i210+ with 8dBi Monopole

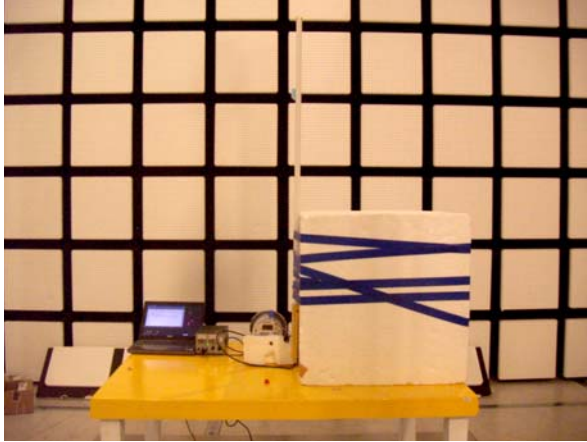

RADIATED RF MEASUREMENT i210+ with 0dBi Puck



RADIATED RF MEASUREMENT i210+ with 8.5dBic Panel



RADIATED RF MEASUREMENT Focus meter with 8dBi Monopole



RADIATED RF MEASUREMENT Focus meter with 0dBi Puck

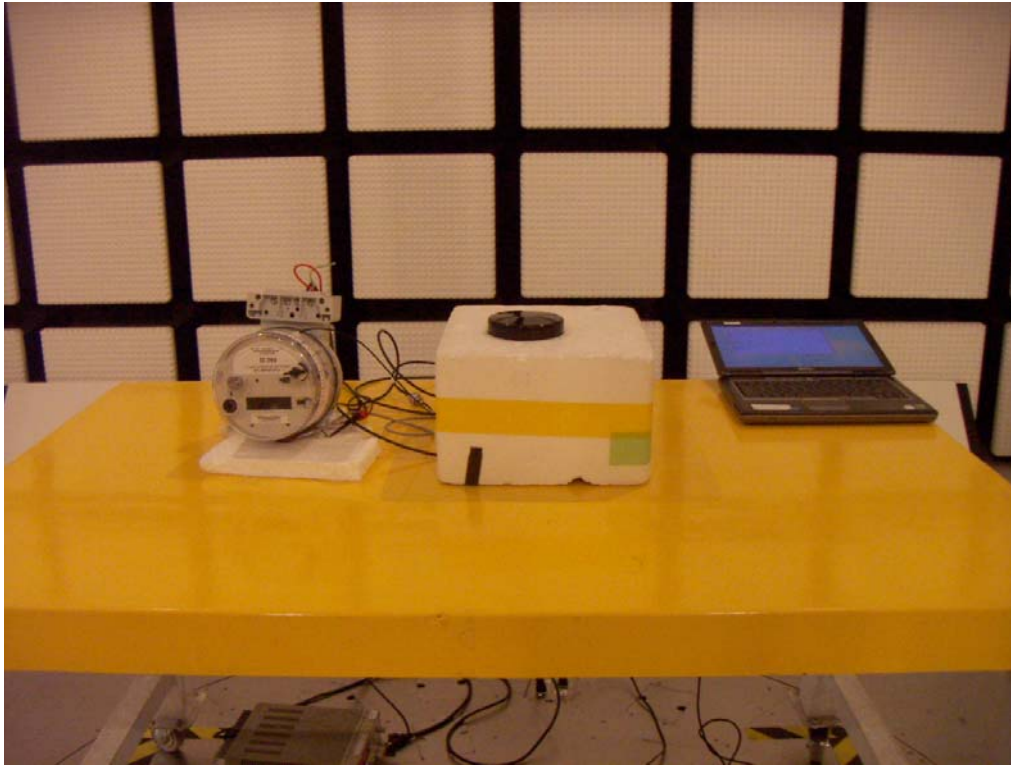

RADIATED RF MEASUREMENT Focus meter with 8.5 dBic Panel



RADIATED RF MEASUREMENT k2VC meter with 8dBi Monopole

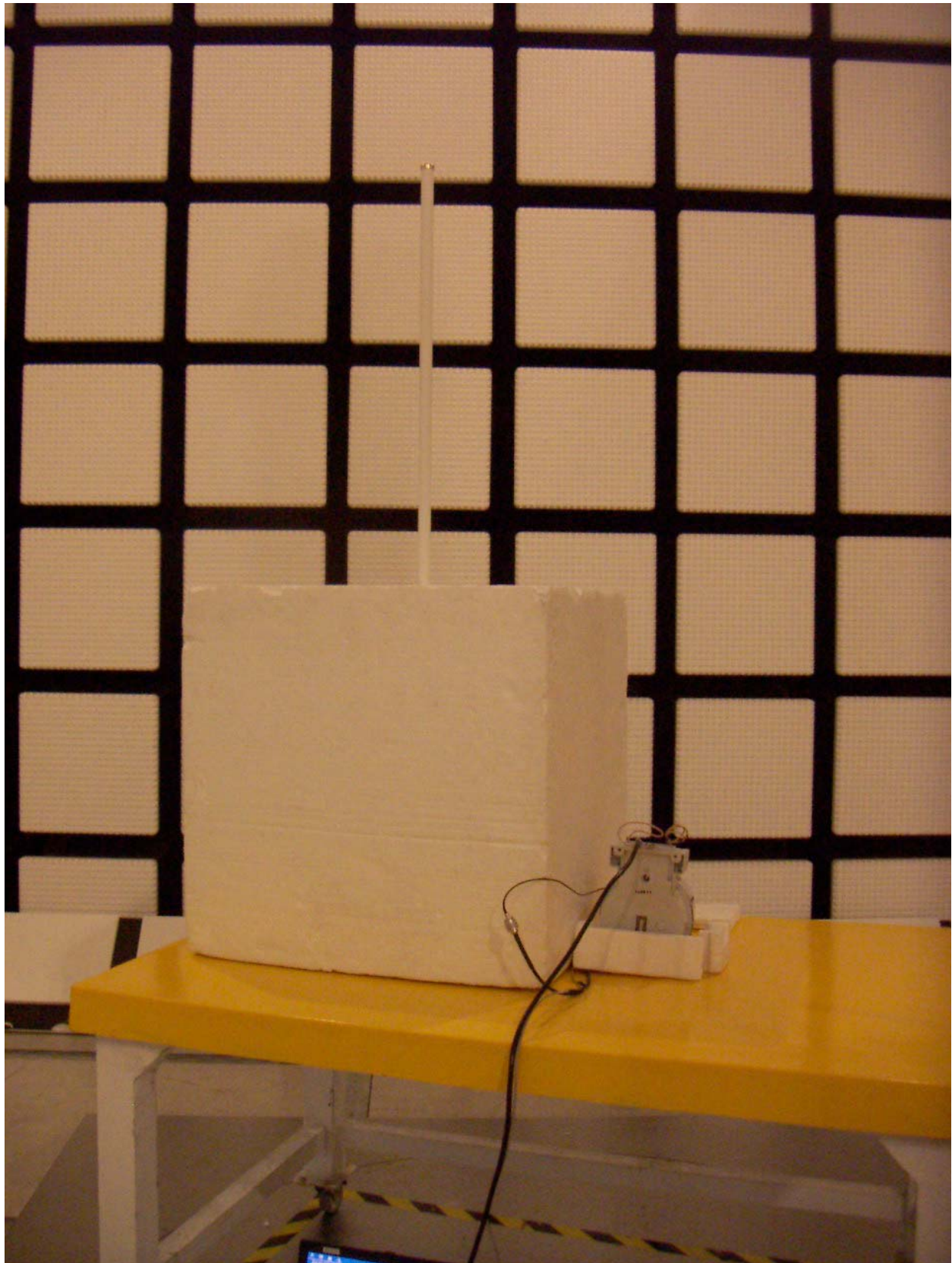

RADIATED RF MEASUREMENT k2VVC meter with 0dBi Puck

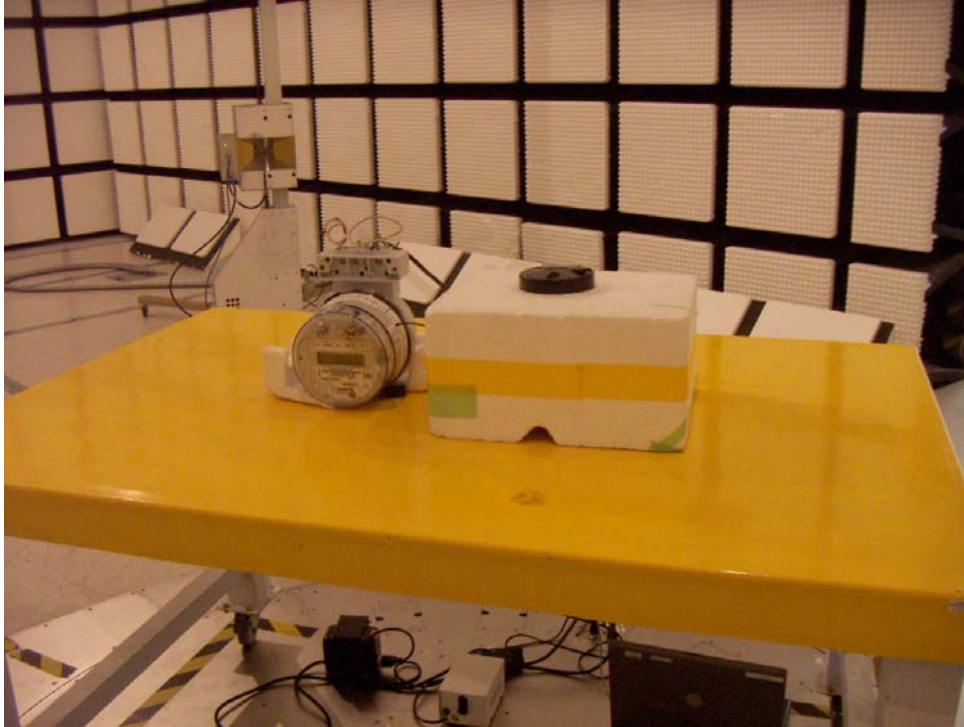

RADIATED RF MEASUREMENT k2VVC meter with 8.5 dBic Panel

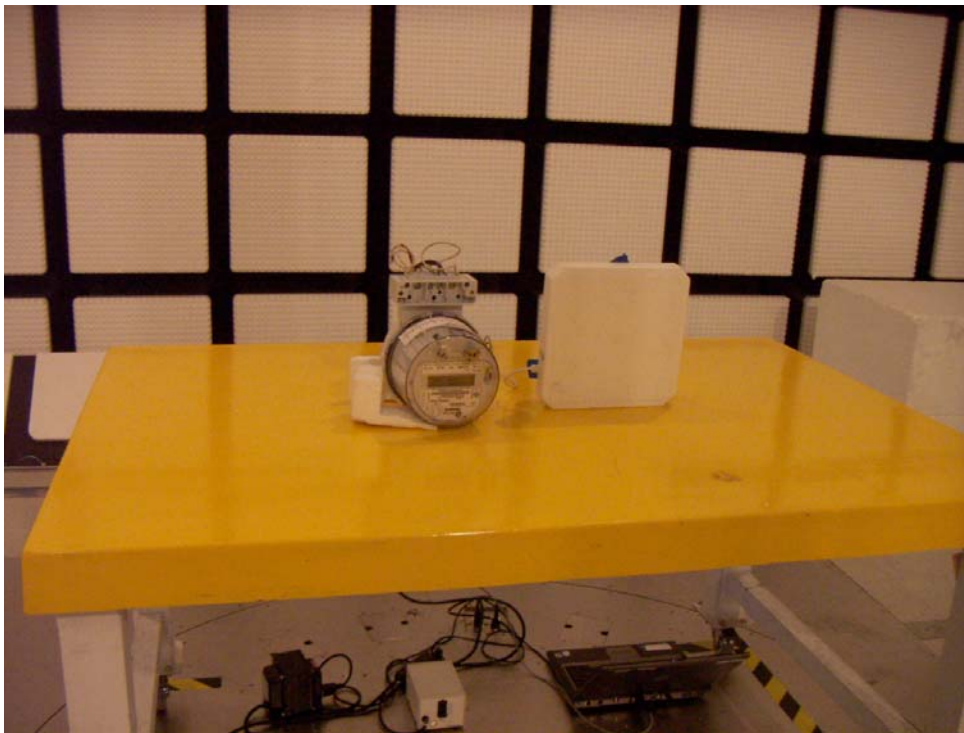

RADIATED RF MEASUREMENT S4e meter with 8.1 dBi Monopole

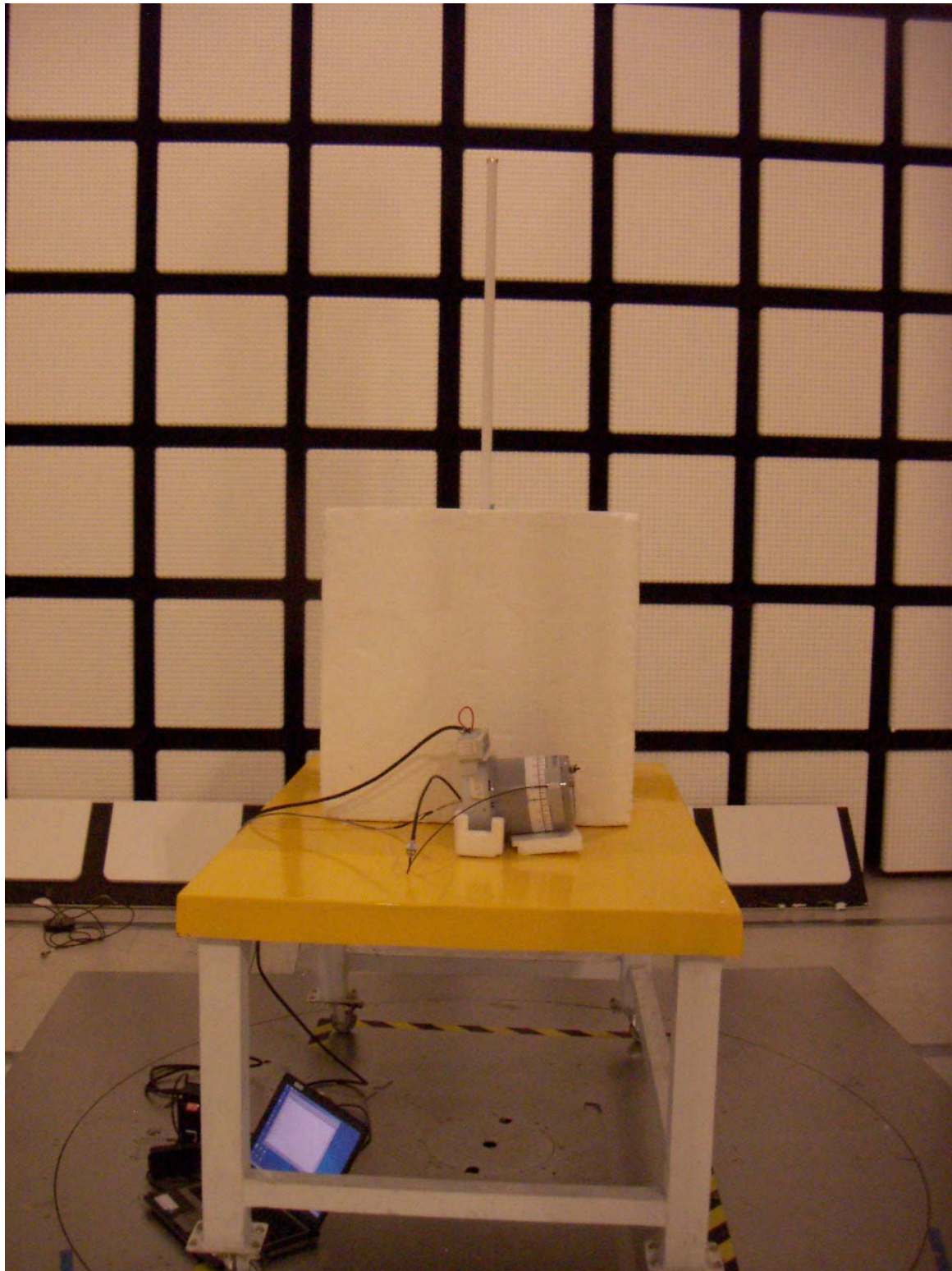

RADIATED RF MEASUREMENT S4e meter with 0dBi Puck

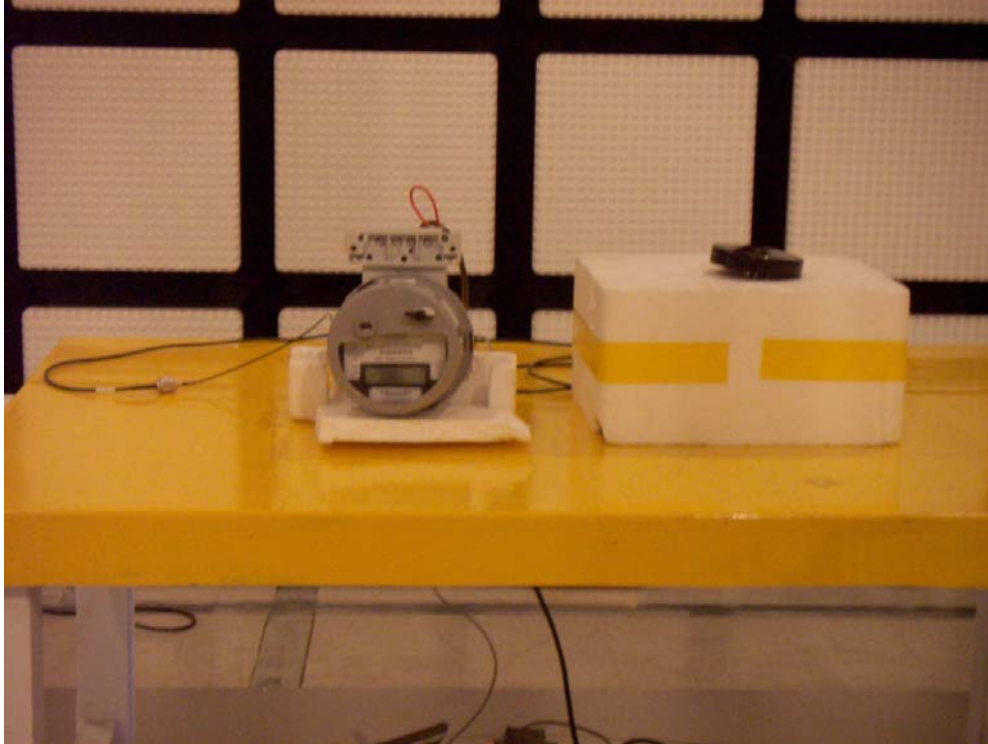

RADIATED RF MEASUREMENT S4e meter with 8.5dBic Panel

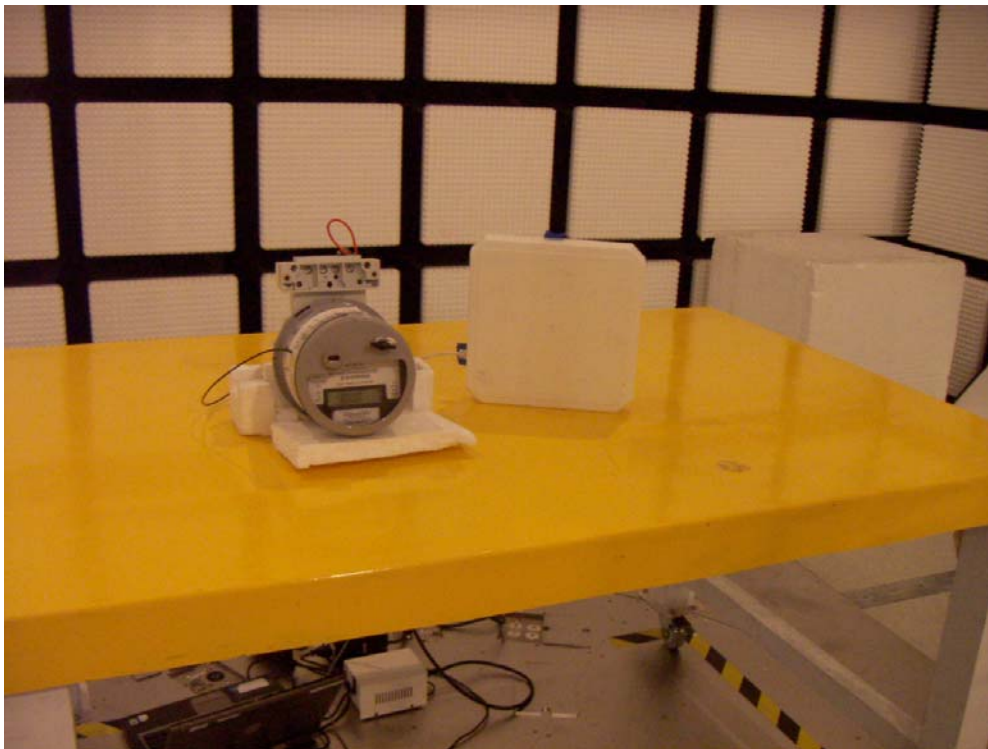

i210+ RX Spurious Antenna Port



Focus RX spurious antenna port

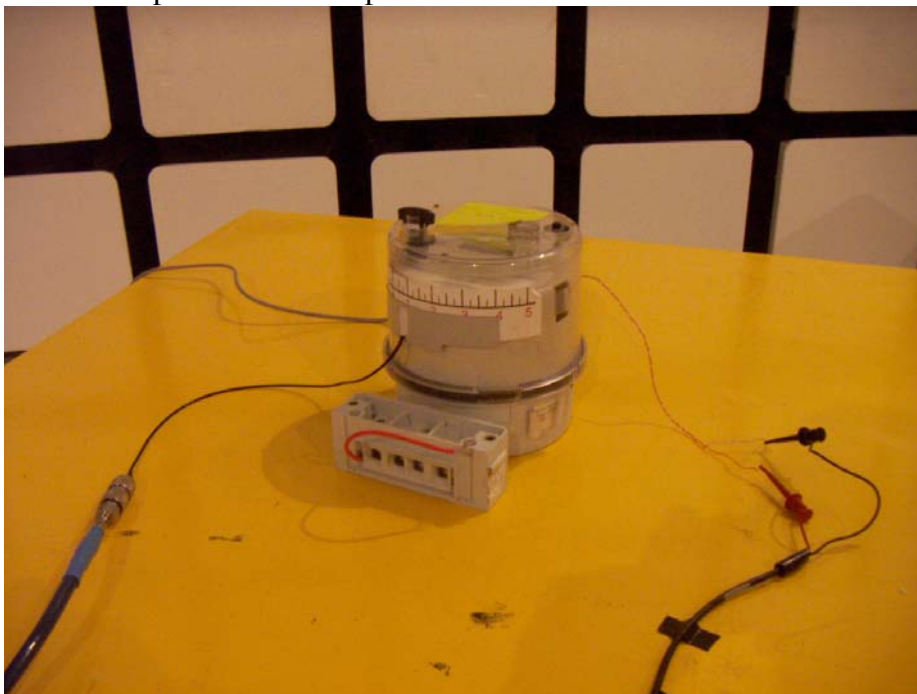

k2VC RX spurious antenna port

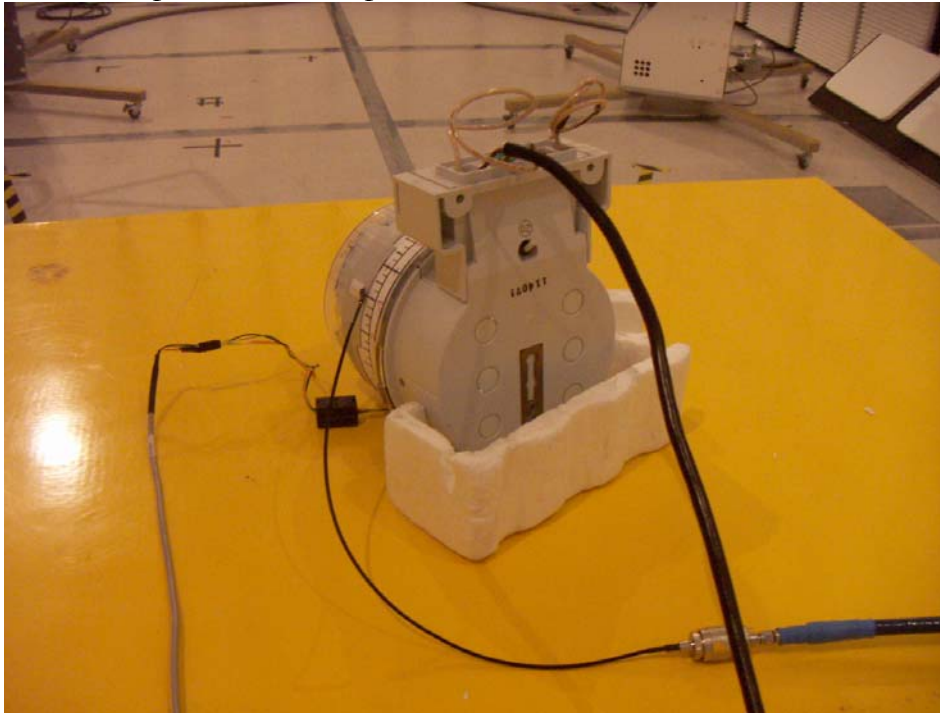

S4e RX spurious antenna port

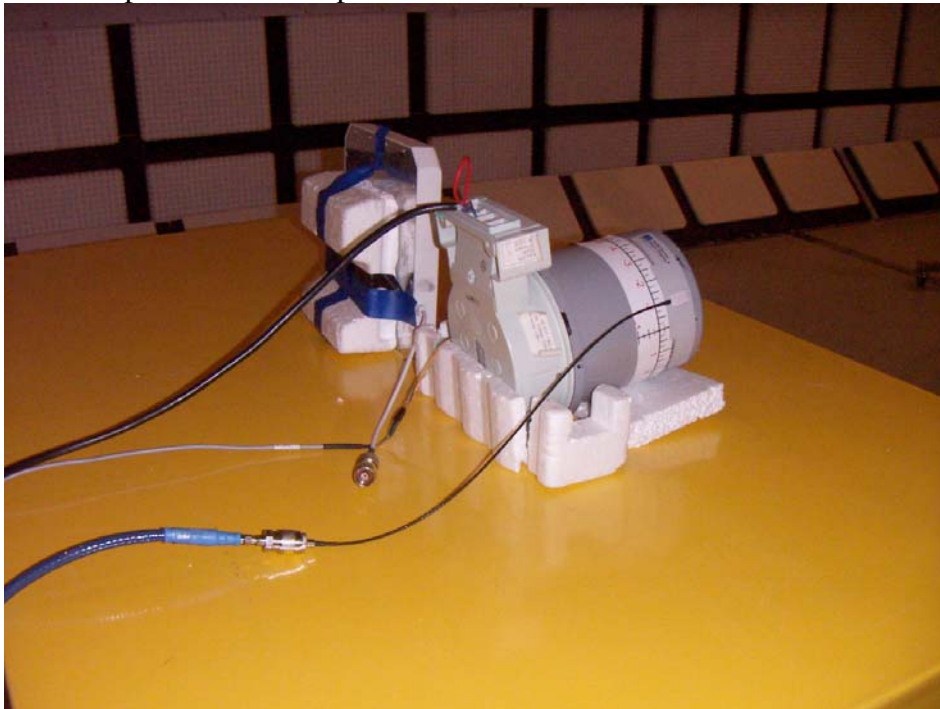

END OF REPORT

Report Revision History

Revision No.	Revision Description	Pages Revised	Revised by	Date
-	Original Issue		T. Cokenias	11/15/2010