

EMISSIONS TEST REPORT FOR A LOW POWER TRANSMITTER

I. GENERAL INFORMATION

Requirement: FCC
Test Requirements: FCC Part 15

Applicant: Silver Spring Networks
575 Broadway Street
Redwood City, CA 94063

FCC ID: OWS-NIC510
IC: 5975A-NIC510
Model No.: 221-010001

II. DESCRIPTION OF EQUIPMENT UNDER TEST (EUT)

The Silver Spring Networks (SSN) model 221-010001 is a battery-operated radio module for gas meter communications use. The board incorporates a 900 MHz frequency hopping i210 Mesh radio.

III. TEST DATES AND TEST LOCATION

Testing was performed on 20 April 2009 and 22 April 2009. Radiated emissions tests were performed at:

Compliance Certification Services
47173 Benicia Street
Fremont, CA 94538

Antenna port conducted tests were performed at Silver Spring Networks.



T.N. Cokenias
EMC Consultant/Agent for Silver Spring Networks

18 May 2009

15.203 Antenna connector requirement

The EUT uses a custom permanently attached integral antenna, a special sheet metal antenna manufactured by Silver Spring Networks for gas meters

Antenna description	Mfr.	Model No.	Gain
Built-in sheet metal electric meter	SSN	n/a	2 dBi at 915 MHz

TEST PROCEDURES

All tests were performed in accordance with the applicable procedures called out in the following documents, unless otherwise noted:

FCC 47CFR15

RSS-210 Issue 7: Low power license exempt radio frequency devices (July 2007)

RSS-212: Test Facilities and Test Methods for Radio Equipment

ANSI C63.4 – 2003, American National Standard for Methods of Measurement of Radio-Noise Emissions from Low-Voltage Electrical and Electronic Equipment in the Range of 9 kHz to 40 GHz.

Tests were performed at three frequencies:

Channel 0 (LOW) – 902.3 MHz

Channel 43 (MID) -915.2 MHz

Channel 82 (HIFH) – 926.9 MHz

Test Equipment

Compliance Certification Services:

Description	Manufacturer	Model	Asset/SN number	Cal due
Bilog antenna	Sunol Sciences	JB1	CO1016	1/14/10
Pre-amplifier	HP	8447D	T64	8/31/09
Horn antenna	EMCO	3115	T73	4/22/09
Pre-amplifier	HP	HP8449B	T144	1/6/10
Spectrum analyzer	Agilent	E4446A	C01069	1/5/10

Silver Spring Networks:

Equipment	Mfr	Model	Asset No.	Cal Due
Spectrum analyzer	Agilent	E4405B	1077004	06/29/09

Test Set-up Diagram

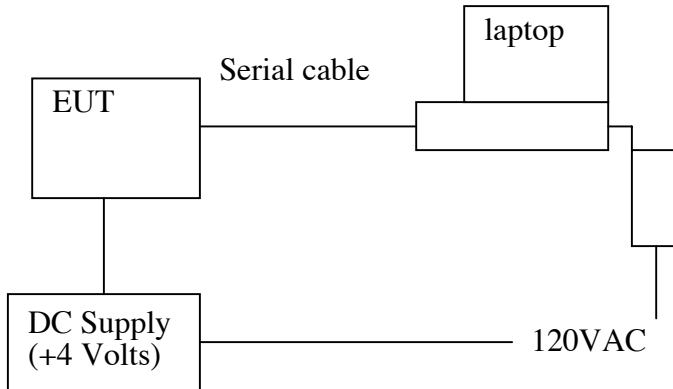

Support Equipment

Equipment	Mfr	Model	Asset No.
DC Power Supply	Agilent	E3610A	2844
Laptop PC	Dell	PP01L	TW-0791UH1280-OC9-6558
AC/DC adapter	CUI Inc.	DSA-60W-20	2607HB

FREQUENCY HOPPING SPREAD SPECTRUM RADIO EMISSIONS

TEST RESULTS

Radiated Test Set-up, 30 MHz-9.3 GHz

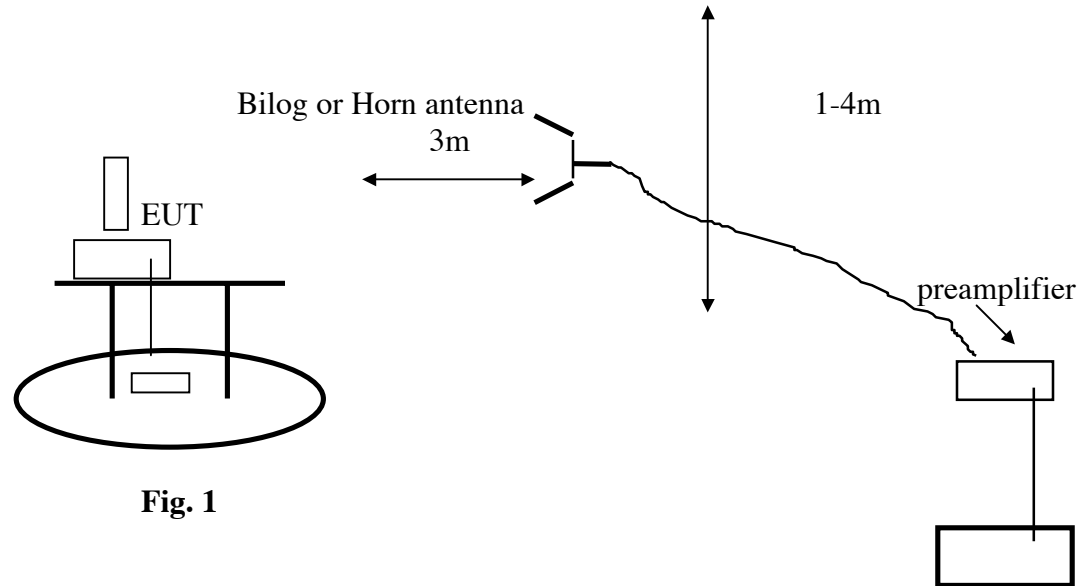

Fig. 1

Test Procedures

Radiated emissions generated by the transmitter portion of the EUT were measured.

1. The EUT was placed on a wooden table resting on a turntable on the test site. The search antenna was placed 3m from the EUT. The EUT antenna was mounted in the with the EUT TX antenna pointed directly to the search antenna.
2. The turntable was slowly rotated to locate the direction of maximum emission at each emission falling in the restricted bands of 15.205.
3. Emissions were investigated to the 10th harmonic of the fundamental.
4. Once maximum direction was determined, the search antenna was raised and lowered in both vertical and horizontal polarizations. The maximum readings so obtained are recorded in the data listed below.

Test Results: Worst-case results are presented. Refer to data sheets below. Restricted band emissions meet 54 dBuV/m. Other undesired emissions from the transmitter meet the -20 dBc requirement in 15.247(d).

15.205 Restricted Frequency Bands

MHz	MHz	MHz	GHz
0.090 - 0.110	16.42 - 16.423	399.9 - 410	4.5 - 5.15
0.495 - 0.505 (1)	16.69475 - 16.69525	608 - 614	5.35 - 5.46
2.1735 - 2.1905	16.80425 - 16.80475	960 - 1240	7.25 - 7.75
4.125 - 4.128	25.5 - 25.67	1300 - 1427	8.025 - 8.5
4.17725 - 4.17775	37.5 - 38.25	1435 - 1626.5	9.0 - 9.2
4.20725 - 4.20775	73 - 74.6	1645.5 - 1646.5	9.3 - 9.5
6.215 - 6.218	74.8 - 75.2	1660 - 1710	10.6 - 12.7
6.26775 - 6.26825	108 - 121.94	1718.8 - 1722.2	13.25 - 13.4
6.31175 - 6.31225	123 - 138	2200 - 2300	14.47 - 14.5
8.291 - 8.294	149.9 - 150.05	2310 - 2390	15.35 - 16.2
8.362 - 8.366	156.52475 -	2483.5 - 2500	17.7 - 21.4
8.37625 - 8.38675	156.52525	2655 - 2900	22.01 - 23.12
8.41425 - 8.41475	156.7 - 156.9	3260 - 3267	23.6 - 24.0
12.29 - 12.293	162.0125 - 167.17	3332 - 3339	31.2 - 31.8
12.51975 - 12.52025	167.72 - 173.2	3345.8 - 3358	36.43 - 36.5
12.57675 - 12.57725	240 - 285	3600 - 4400	
13.36 - 13.41	322 - 335.4		

15.209 General Field Strength Limits

Frequency (MHz)	Field Strength (microvolts/meter)	Measurement Distance (meters)
0.009 - 0.490	2400/F(kHz)	300
0.490 - 1.705	24000/F(kHz)	30
1.705 - 30.0	30	30
30 - 88	100 **	3
88 - 216	150 **	3
216 - 960	200 **	3
Above 960	500	3

Radiated Emissions, Fundamental Frequency, in 100 kHz RBW

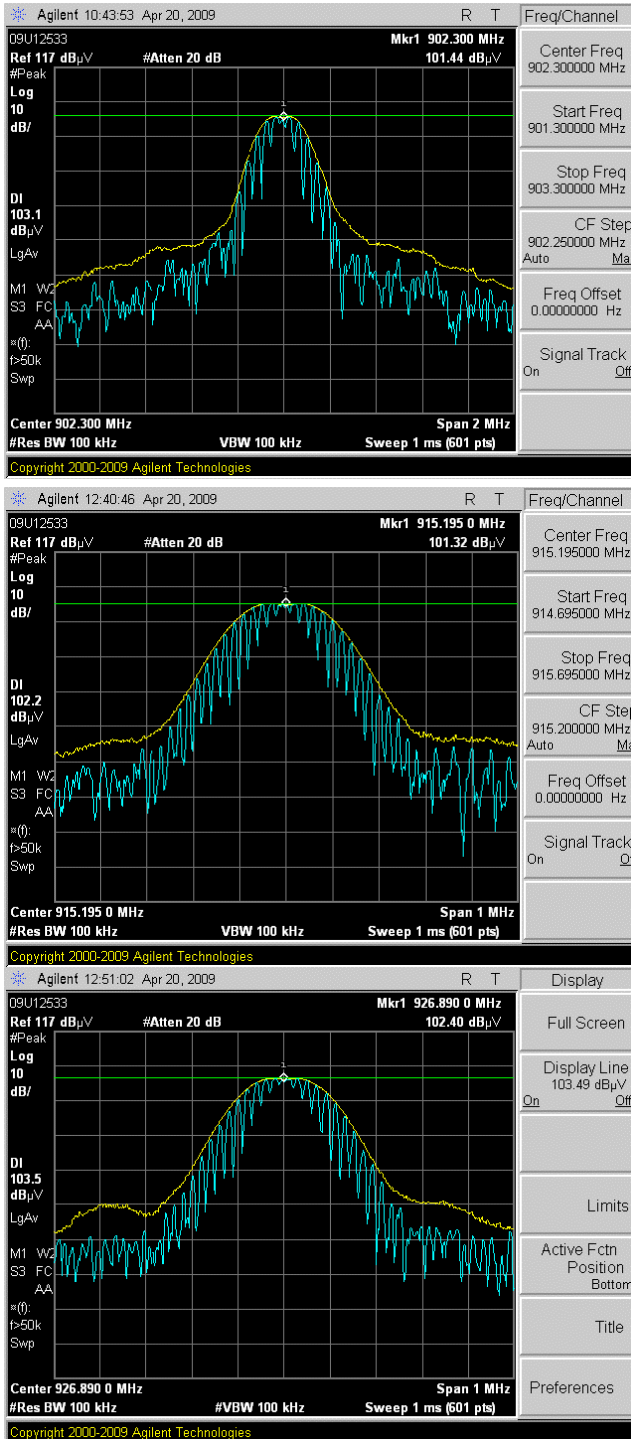

Radiated Emissions Above 1 GHz

High Frequency Measurement																																													
Compliance Certification Services, Fremont 5m Chamber																																													
Company:		Silver Spring Networks																																											
Project #:		09U12533																																											
Date:		04/20/09																																											
Test Engineer:		Thanh Nguyen																																											
Configuration:		EUT, support Laptop, DC Power Supply																																											
Mode:		Transmit																																											
Test Equipment:																																													
Horn 1-18GHz			Pre-amplifer 1-26GHz			Pre-amplifer 26-40GHz			Horn > 18GHz																																				
T59; S/N: 3245 @3m			T145 Agilent 3008A005																																										
Hi Frequency Cables																																													
3' cable 22807700			12' cable 22807600			20' cable 22807500			HPF			Reject Filter			Peak Measurements RBW=VBW=1MHz																														
3' cable 22807700			12' cable 22807600			20' cable 22807500			HPF_1.5GHz						Average Measurements RBW=1MHz ; VBW=10Hz																														
f GHz	Dist (m)	Read Pk dBuV	Read Avg. dBuV	AF dB/m	CL dB	Amp dB	D Corr dB	Filtr dB	Peak dBuV/m	Avg dBuV/m	Pk Lim dBuV/m	Avg Lim dBuV/m	Pk Mar dB	Avg Mar dB	Notes (V/H)																														
Low Ch 902.3MHz:																																													
1.805	3.0	77.7	77.6	26.9	3.3	-35.5	0.0	0.3	72.7	72.5	81.4	81.4	-8.7	-8.9	101.44 dBuV/m 100kHz RBW H																														
2.707	3.0	54.0	50.0	29.1	4.1	-35.2	0.0	0.6	52.7	48.6	74.0	74.0	-21.3	-5.4	H																														
3.609	3.0	46.6	41.2	31.3	4.8	-34.9	0.0	0.6	48.4	43.0	74	74	-25.6	-11.0	H																														
4.511	3.0	47.1	43.6	32.5	5.6	-34.8	0.0	0.6	51.0	47.4	74	74	-23.0	-6.6	H																														
5.414	3.0	48.0	43.6	33.4	6.2	-34.9	0.0	0.5	53.2	48.9	74	74	-20.8	-5.1	H																														
1.805	3.0	76.9	76.3	26.9	3.3	-35.5	0.0	0.3	71.8	71.2	84.0	84.0	-12.2	-12.8	V																														
2.707	3.0	55.4	54.1	29.1	4.1	-35.2	0.0	0.6	54.0	52.7	74	74	-20.0	-1.3	V																														
3.609	3.0	49.6	46.3	31.3	4.8	-34.9	0.0	0.6	51.4	48.1	74	74	-22.6	-5.9	V																														
4.511	3.0	48.8	43.6	32.5	5.6	-34.8	0.0	0.6	52.7	47.5	74	74	-21.3	-6.5	V																														
5.414	3.0	45.8	41.0	33.4	6.2	-34.9	0.0	0.5	51.0	46.3	74	74	-23.0	-7.7	V																														
Mid Channel 915.2MHz																																													
1.830	3.0	74.9	74.5	27.0	3.3	-35.5	0.0	0.3	70.0	69.6	81.3	81.3	-11.3	-11.7	101.32 dBuV/m 100 kHz RBW H																														
2.476	3.0	55.6	53.2	28.4	3.9	-35.1	0.0	0.6	53.4	51.0	74.0	74.0	-20.6	-3.0	H																														
3.661	3.0	47.4	42.4	31.4	4.9	-34.9	0.0	0.6	49.3	44.4	74	74	-24.7	-9.6	H																														
4.576	3.0	46.4	40.2	32.6	5.6	-34.8	0.0	0.6	50.4	44.2	74	74	-23.6	-9.8	H																														
1.830	3.0	75.7	75.5	27.0	3.3	-35.5	0.0	0.3	70.8	70.6	82.4	82.4	-11.6	-11.8	V																														
2.476	3.0	54.5	52.3	28.4	3.9	-35.1	0.0	0.6	52.3	50.1	82.4	82.4	-30.1	-32.3	V																														
3.661	3.0	45.7	43.1	31.4	4.9	-34.9	0.0	0.6	47.7	45.0	74	74	-26.3	-9.0	V																														
4.576	3.0	51.4	48.1	32.6	5.6	-34.8	0.0	0.6	55.4	52.0	74	74	-18.6	-2.0	V																														
High channel 926.89MHz																																													
1.857	3.0	72.4	71.8	27.1	3.3	-35.5	0.0	0.3	67.7	67.0	82.4	82.4	-14.7	-15.4	H																														
2.780	3.0	57.1	54.5	29.4	4.2	-35.2	0.0	0.6	56.0	53.4	74.0	74.0	-18.0	-6.6	H																														
3.707	3.0	52.6	45.1	31.5	4.9	-34.9	0.0	0.6	54.7	47.2	74	74	-19.3	-6.8	H																														
4.634	3.0	53.4	49.0	32.6	5.7	-34.8	0.0	0.6	57.4	53.1	74	74	-16.6	-0.9	H																														
5.561	3.0	48.4	37.9	33.6	6.3	-35.0	0.0	0.5	53.8	43.3	82.4	82.4	-28.6	-39.1	H																														
1.857	3.0	72.4	71.8	27.1	3.3	-35.5	0.0	0.3	67.7	67.0	82.4	82.4	-14.7	-15.4	V																														
2.780	3.0	55.5	49.3	29.4	4.2	-35.2	0.0	0.6	54.4	48.2	74.0	74.0	-19.6	-5.8	V																														
3.707	3.0	52.6	47.2	31.5	4.9	-34.9	0.0	0.6	54.8	49.3	74	74	-19.2	-4.7	V																														
4.634	3.0	54.2	49.6	32.6	5.7	-34.8	0.0	0.6	58.2	53.6	74	74	-15.8	-0.4	V																														
5.561	3.0	49.9	41.5	33.6	6.3	-35.0	0.0	0.5	55.3	46.9	82.4	82.4	-27.1	-35.5	V																														
<table border="0"> <tr> <td>f</td> <td>Measurement Frequency</td> <td>Amp</td> <td>Preamp Gain</td> <td>Avg Lim</td> <td>Average Field Strength Limit</td> </tr> <tr> <td>Dist</td> <td>Distance to Antenna</td> <td>D Corr</td> <td>Distance Correct to 3 meters</td> <td>Pk Lim</td> <td>Peak Field Strength Limit</td> </tr> <tr> <td>Read</td> <td>Analyzer Reading</td> <td>Avg</td> <td>Average Field Strength @ 3 m</td> <td>Avg Mar</td> <td>Margin vs. Average Limit</td> </tr> <tr> <td>AF</td> <td>Antenna Factor</td> <td>Peak</td> <td>Calculated Peak Field Strength</td> <td>Pk Mar</td> <td>Margin vs. Peak Limit</td> </tr> <tr> <td>CL</td> <td>Cable Loss</td> <td>HPF</td> <td>High Pass Filter</td> <td></td> <td></td> </tr> </table>																f	Measurement Frequency	Amp	Preamp Gain	Avg Lim	Average Field Strength Limit	Dist	Distance to Antenna	D Corr	Distance Correct to 3 meters	Pk Lim	Peak Field Strength Limit	Read	Analyzer Reading	Avg	Average Field Strength @ 3 m	Avg Mar	Margin vs. Average Limit	AF	Antenna Factor	Peak	Calculated Peak Field Strength	Pk Mar	Margin vs. Peak Limit	CL	Cable Loss	HPF	High Pass Filter		
f	Measurement Frequency	Amp	Preamp Gain	Avg Lim	Average Field Strength Limit																																								
Dist	Distance to Antenna	D Corr	Distance Correct to 3 meters	Pk Lim	Peak Field Strength Limit																																								
Read	Analyzer Reading	Avg	Average Field Strength @ 3 m	Avg Mar	Margin vs. Average Limit																																								
AF	Antenna Factor	Peak	Calculated Peak Field Strength	Pk Mar	Margin vs. Peak Limit																																								
CL	Cable Loss	HPF	High Pass Filter																																										

Radiated Emissions Below 1 GHZ

Low Channel

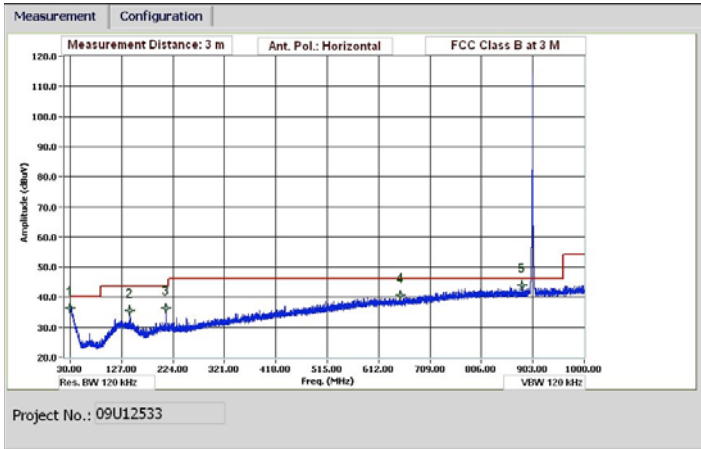

Mid Channel

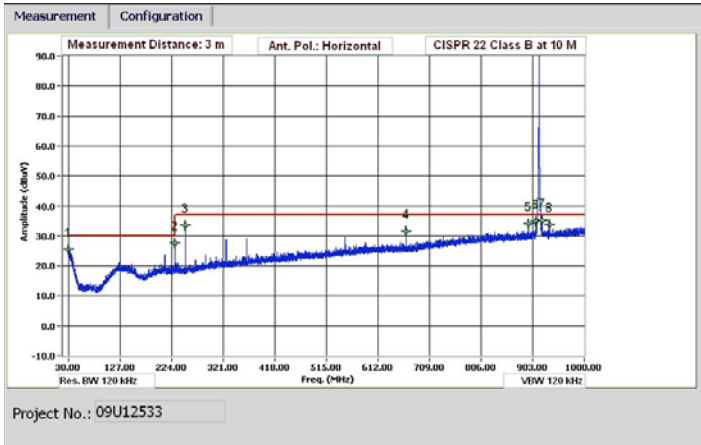

High Channel

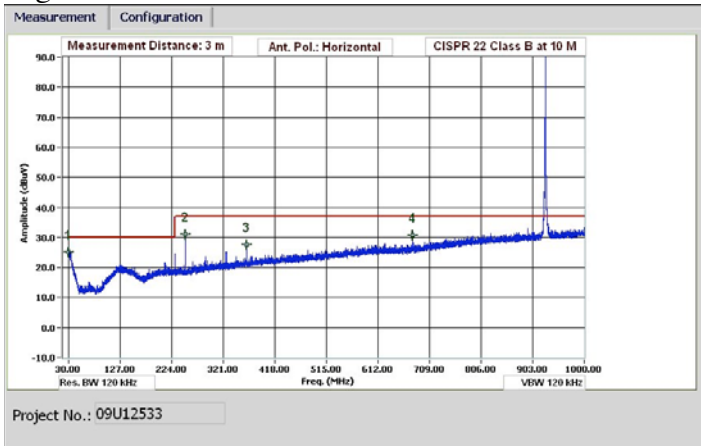

f MHz	Dist (m)	Read dBuV	AF dB/m	CL dB	Amp dB	D Corr dB	Filter dB	Corr. dBuV/m	Limit dBuV/m	Margin dB	Ant. Pol. V/H	Det. P/A/QP
Low Channel												
32.906	3.0	45.9	19.0	0.5	28.4	0.0	0.0	37.0	40.0	-3.0	V	P
695.820	3.0	47.9	19.2	2.6	27.2	0.0	0.0	42.5	46.0	-3.5	V	P
886.223	3.0	46.8	21.5	3.0	27.7	0.0	0.0	43.5	46.0	-2.5	V	P
30.120	3.0	43.9	20.3	0.5	28.4	0.0	0.0	36.3	40.0	-3.7	H	P
143.165	3.0	49.6	13.0	1.1	28.3	0.0	0.0	35.4	43.5	-8.1	H	P
211.207	3.0	51.2	12.0	1.3	28.2	0.0	0.0	36.3	43.5	-7.2	H	P
653.546	3.0	46.7	18.8	2.5	27.3	0.0	0.0	40.6	46.0	-5.4	H	P
883.115	3.0	47.2	21.4	3.0	27.7	0.0	0.0	43.9	46.0	-2.1	H	P

Rev. 1.27.09

Note: No other emissions were detected above the system noise floor.

Receiver Radiated Emissions

No emissions detected from receiver 30 – 5000 MHz. System noise floor more than 20 dB below receiver radiated emissions limit noise floor.

20 dB Bandwidth

LIMIT

None; for reporting purposes only.

TEST PROCEDURE

The transmitter output is connected to a spectrum analyzer. The RBW is set to approximately 5% of the 20 dB bandwidth. The VBW is set to 3 times the RBW. The sweep time is coupled.

RESULTS

No non-compliance noted:

Channel	Frequency (MHz)	20 dB Bandwidth (kHz)
Low	902.3	213.8
Middle	915.2	211.8
High	926.9	203.4

Emission Designator: 214KF1D

20 dB BANDWIDTH LOW CHANNEL

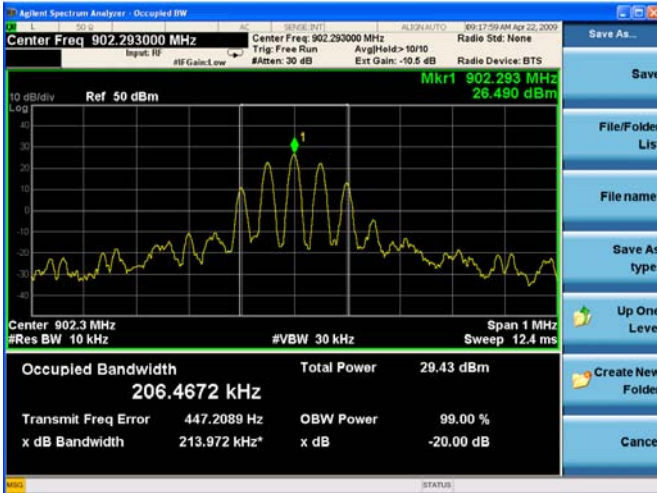

20 dB BANDWIDTH MID CHANNEL

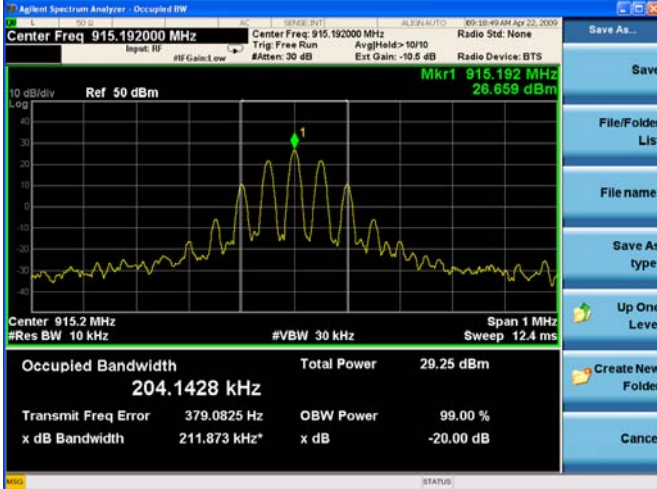

20 dB BANDWIDTH HIGH CHANNEL

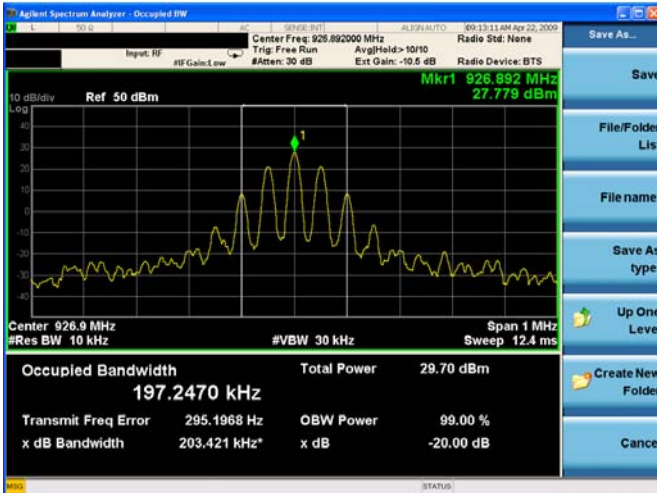

HOPPING FREQUENCY SEPARATION

LIMIT

§15.247 (a) (1) Frequency hopping systems shall have hopping channel carrier frequencies separated by a minimum of 25 kHz or the 20 dB bandwidth of the hopping channel, whichever is greater.

TEST PROCEDURE

The transmitter output is connected to a spectrum analyzer. The RBW is set to 30 kHz and the VBW is set to 100 kHz. The sweep time is coupled.

RESULTS

No non-compliance noted:

The separation is 300 kHz.

HOPPING FREQUENCY SEPARATION

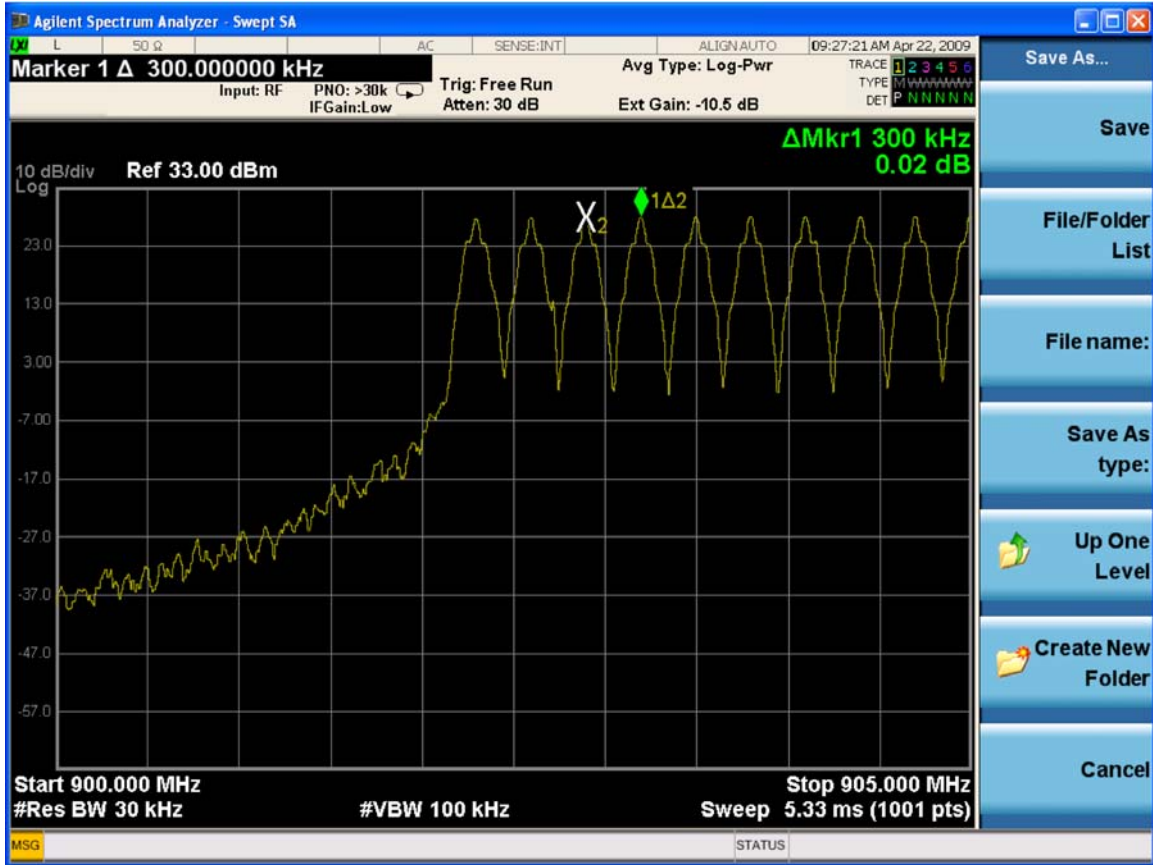

NUMBER OF HOPPING CHANNELS

LIMIT

§15.247 (a) (1) (i) For frequency hopping systems operating in the 902–928 MHz band: if the 20 dB bandwidth of the hopping channel is less than 250 kHz, the system shall use at least 50 hopping frequencies and the average time of occupancy on any frequency shall not be greater than 0.4 seconds within a 20 second period; if the 20 dB bandwidth of the hopping channel is 250 kHz or greater, the system shall use at least 25 hopping frequencies and the average time of occupancy on any frequency shall not be greater than 0.4 seconds within a 10 second period. The maximum allowed 20 dB bandwidth of the hopping channel is 500 kHz.

TEST PROCEDURE

The transmitter output is connected to a spectrum analyzer. The span is set to cover the entire authorized band, in either a single sweep or in multiple contiguous sweeps. The RBW is set to 30 kHz. The analyzer is set to Max Hold.

RESULTS

No non-compliance noted:

83 Channels observed.

NUMBER OF HOPPING CHANNELS

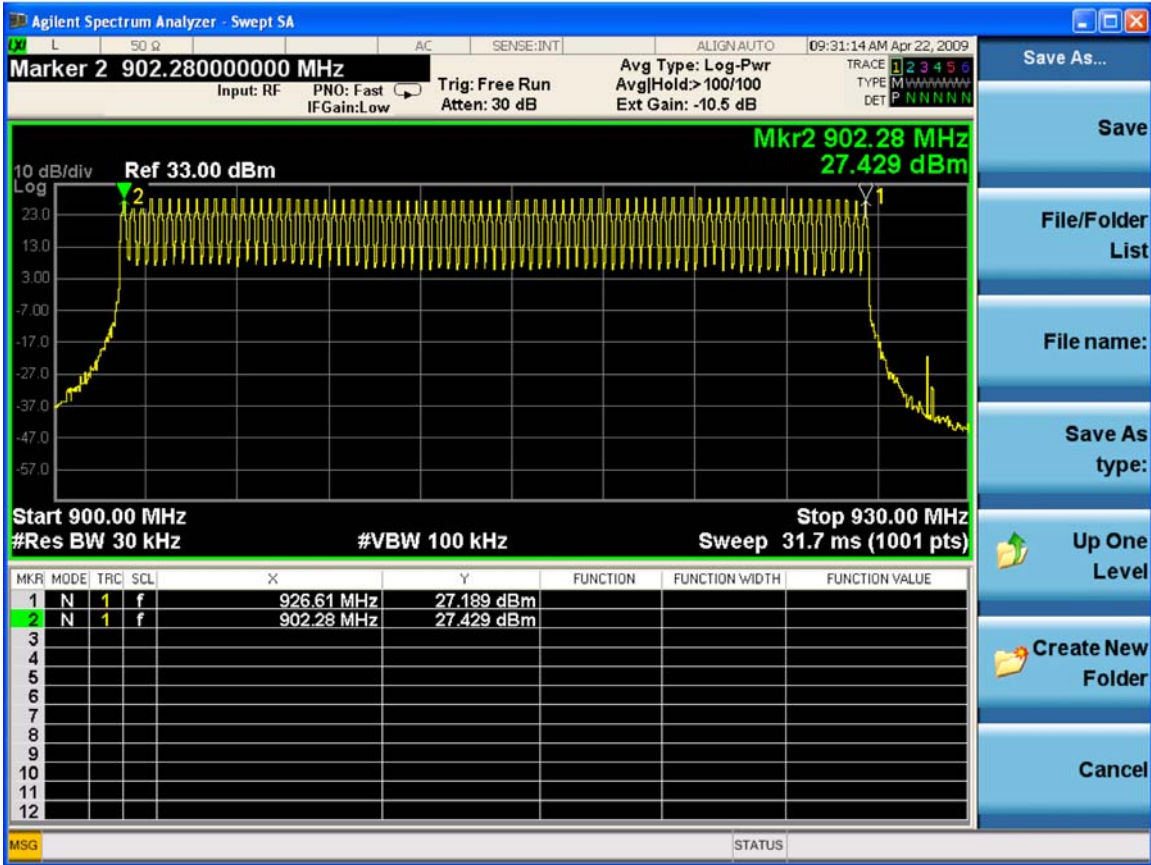

AVERAGE TIME OF OCCUPANCY

LIMIT

§15.247 (a) (1) (i) For frequency hopping systems operating in the 902–928 MHz band: if the 20 dB bandwidth of the hopping channel is less than 250 kHz, the system shall use at least 50 hopping frequencies and the average time of occupancy on any frequency shall not be greater than 0.4 seconds within a 20 second period; if the 20 dB bandwidth of the hopping channel is 250 kHz or greater, the system shall use at least 25 hopping frequencies and the average time of occupancy on any frequency shall not be greater than 0.4 seconds within a 10 second period. The maximum allowed 20 dB bandwidth of the hopping channel is 500 kHz.

TEST PROCEDURE

The transmitter output is connected to a spectrum analyzer. The span is set to 0 Hz, centered on a single, selected hopping channel. The width of a single pulse is measured in a fast scan. The number of pulses is measured in a 20 second scan, to enable resolution of each occurrence.

RESULTS

No non-compliance noted:

There are 4 pulses within the 20-second period. The on time for each pulse is 66 msec.

Therefore, the average time of occupancy in the specified 20-second period is 266 msec.

PULSE WIDTH

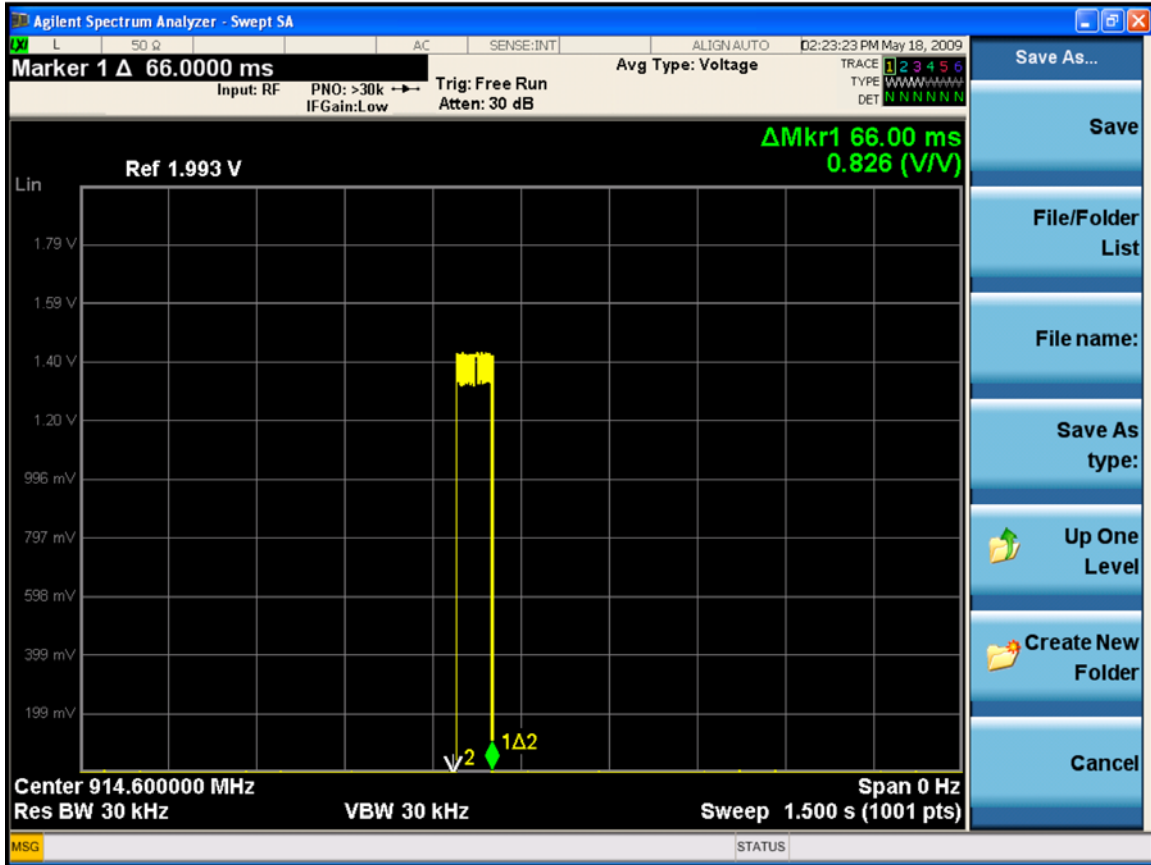

NUMBER OF PULSES IN 20 SECOND OBSERVATION PERIOD

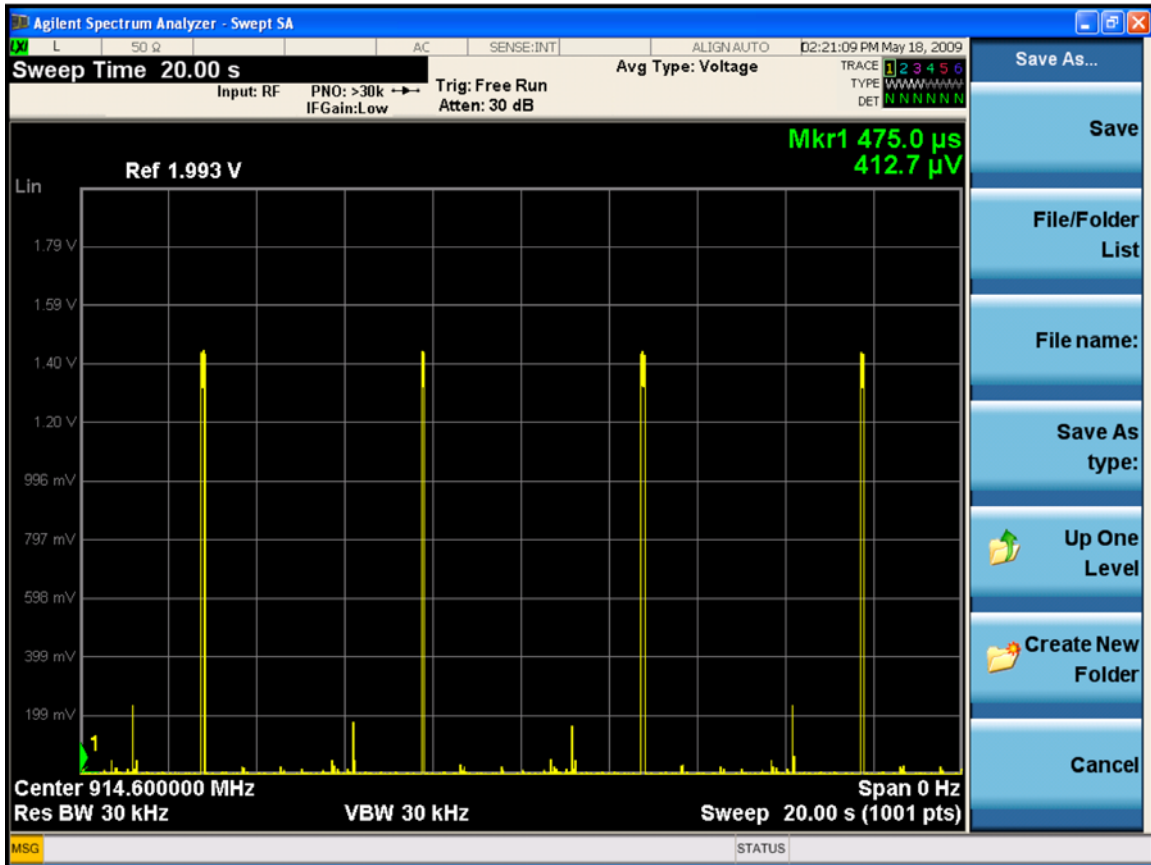

PEAK OUTPUT POWER

PEAK POWER LIMIT

§15.247 (b) The maximum peak output power of the intentional radiator shall not exceed the following:

§15.247 (b) (2) For frequency hopping systems operating in the 902-928 MHz band, employing at least 50 hopping channels: 1 watt; and employing less than 50 hopping channels, but at least 25 hopping channels: 0.25 watt.

§15.247 (b) (4) Except as shown in paragraphs (b)(3) (i), (ii) and (iii) of this section, if transmitting antennas of directional gain greater than 6 dBi are used the peak output power from the intentional radiator shall be reduced below the stated values in paragraphs (b)(1) or (b)(2) of this section, as appropriate, by the amount in dB that the directional gain of the antenna exceeds 6 dBi.

The maximum antenna gain is 0 dBi, therefore the power limit is 30 dBm.

TEST PROCEDURE

The transmitter output is connected to a spectrum analyzer and the analyzer bandwidth is set to a value greater than the 20 dB bandwidth of the EUT.

RESULTS

No non-compliance noted:

Channel	Frequency	P out
Low	902.3	29.52
Mid	915.2	29.3
High	926.9	29.79

OUTPUT POWER LOW CHANNEL



OUTPUT POWER MID CHANNEL

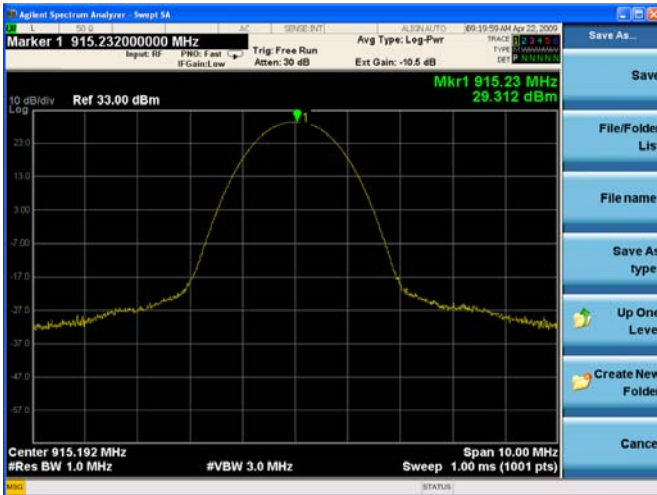

OUTPUT POWER HIGH CHANNEL



MAXIMUM PERMISSIBLE EXPOSURE

LIMITS

§1.1310 The criteria listed in Table 1 shall be used to evaluate the environmental impact of human exposure to radio-frequency (RF) radiation as specified in §1.1307(b), except in the case of portable devices which shall be evaluated according to the provisions of §2.1093 of this chapter.

TABLE 1—LIMITS FOR MAXIMUM PERMISSIBLE EXPOSURE (MPE)

Frequency range (MHz)	Electric field strength (V/m)	Magnetic field strength (A/m)	Power density (mW/cm ²)	Averaging time (minutes)
(A) Limits for Occupational/Controlled Exposures				
0.3–3.0	614	1.63	*(100)	6
3.0–30	1842/f	4.89/f	*(900/f ²)	6
30–300	61.4	0.163	1.0	6
300–1500			f/300	6
1500–100,000			5	6
(B) Limits for General Population/Uncontrolled Exposure				
0.3–1.34	614	1.63	*(100)	30
1.34–30	824/f	2.19/f	*(180/f ²)	30

TABLE 1—LIMITS FOR MAXIMUM PERMISSIBLE EXPOSURE (MPE)—Continued

Frequency range (MHz)	Electric field strength (V/m)	Magnetic field strength (A/m)	Power density (mW/cm ²)	Averaging time (minutes)
30–300	27.5	0.073	0.2	30
300–1500			f/1500	30
1500–100,000			1.0	30

f = frequency in MHz

* = Plane-wave equivalent power density

NOTE 1 TO TABLE 1: Occupational/controlled limits apply in situations in which persons are exposed as a consequence of their employment provided those persons are fully aware of the potential for exposure and can exercise control over their exposure. Limits for occupational/controlled exposure also apply in situations when an individual is transient through a location where occupational/controlled limits apply provided he or she is made aware of the potential for exposure.

NOTE 2 TO TABLE 1: General population/uncontrolled exposures apply in situations in which the general public may be exposed, or in which persons that are exposed as a consequence of their employment may not be fully aware of the potential for exposure or can not exercise control over their exposure.

CALCULATIONS

Given

$$E = \sqrt{(30 * P * G) / d}$$

and

$$S = E^2 / 3770$$

where

E = Field Strength in Volts/meter

P = Power in Watts

G = Numeric antenna gain

d = Distance in meters

S = Power Density in milliwatts/square centimeter

Combining equations and rearranging the terms to express the distance as a function of the remaining variables yields:

$$d = \sqrt{((30 * P * G) / (3770 * S))}$$

Changing to units of Power to mW and Distance to cm, using:

$$P \text{ (mW)} = P \text{ (W)} / 1000 \text{ and}$$

$$d \text{ (cm)} = 100 * d \text{ (m)}$$

yields

$$d = 100 * \sqrt{((30 * (P / 1000) * G) / (3770 * S))}$$

$$d = 0.282 * \sqrt{(P * G / S)}$$

where

d = distance in cm

P = Power in mW

G = Numeric antenna gain

S = Power Density in mW/cm²

Substituting the logarithmic form of power and gain using:

$$P \text{ (mW)} = 10^{(P \text{ (dBm)} / 10)} \text{ and}$$

$$G \text{ (numeric)} = 10^{(G \text{ (dBi)} / 10)}$$

yields

$$d = 0.282 * 10^{((P + G) / 20)} / \sqrt{S} \quad \text{Equation (1)}$$

where

d = MPE distance in cm

P = Power in dBm

G = Antenna Gain in dBi

S = Power Density Limit in mW/cm²

Equation (1) and the measured peak power is used to calculate the MPE distance.

LIMITS

From §1.1310 Table 1 (B), $S = 0.6 \text{ mW/cm}^2$

RESULTS

No non-compliance noted:

Power Density Limit (mW/cm²)	Output Power (dBm)	Antenna Gain (dBi)	S, mW/cm² at 20cm
0.6	29.79	2.00	0.30

MPE Distance: 11.24 cm

NOTE: For mobile or fixed location transmitters, the minimum separation distance is 20 cm, even if calculations indicate that the MPE distance would be less.

CONDUCTED SPURIOUS EMISSIONS

LIMITS

§15.247 (c) In any 100 kHz bandwidth outside the frequency band in which the spread spectrum intentional radiator is operating, the radio frequency power that is produced by the intentional radiator shall be at least 20 dB below that in the 100 kHz bandwidth within the band that contains the highest level of the desired power, based on either an RF conducted or a radiated measurement. Attenuation below the general limits specified in §15.209(a) is not required. In addition, radiated emissions which fall in the restricted bands, as defined in §15.205(a), must also comply with the radiated emission limits specified in §15.209(a) (see §15.205(c)).

TEST PROCEDURE

The transmitter output is connected to a spectrum analyzer. The resolution bandwidth is set to 100 kHz. The video bandwidth is set to 100 kHz.

The spectrum from 30 MHz to 10 GHz is investigated with the transmitter set to the lowest, middle, and highest channels.

RESULTS

No non-compliance noted:

SPURIOUS EMISSIONS, LOW CHANNEL, HOPPING



SPURIOUS EMISSIONS, LOW CHANNEL

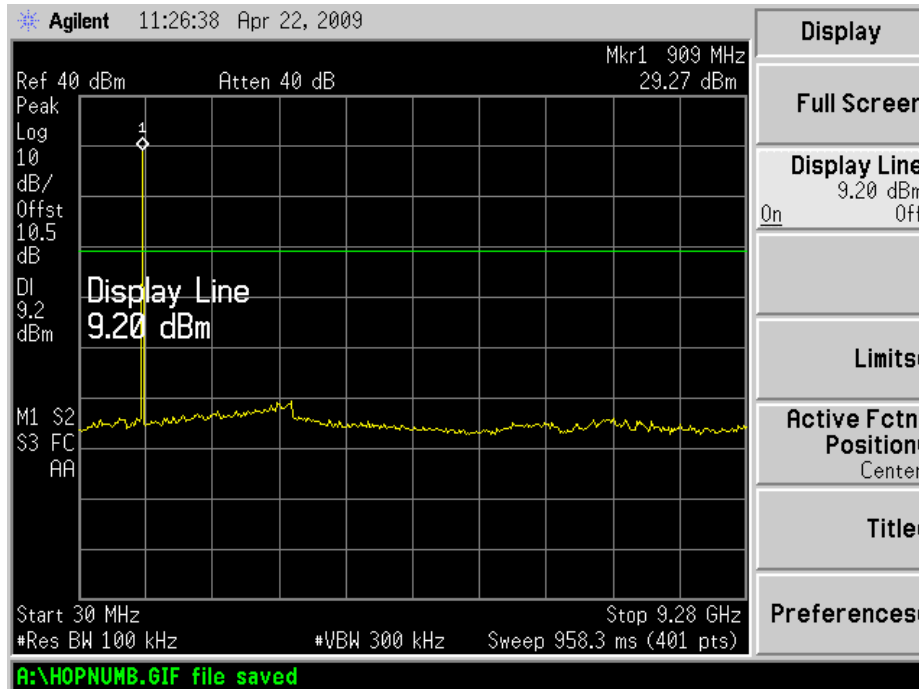

SPURIOUS EMISSIONS, MID CHANNEL

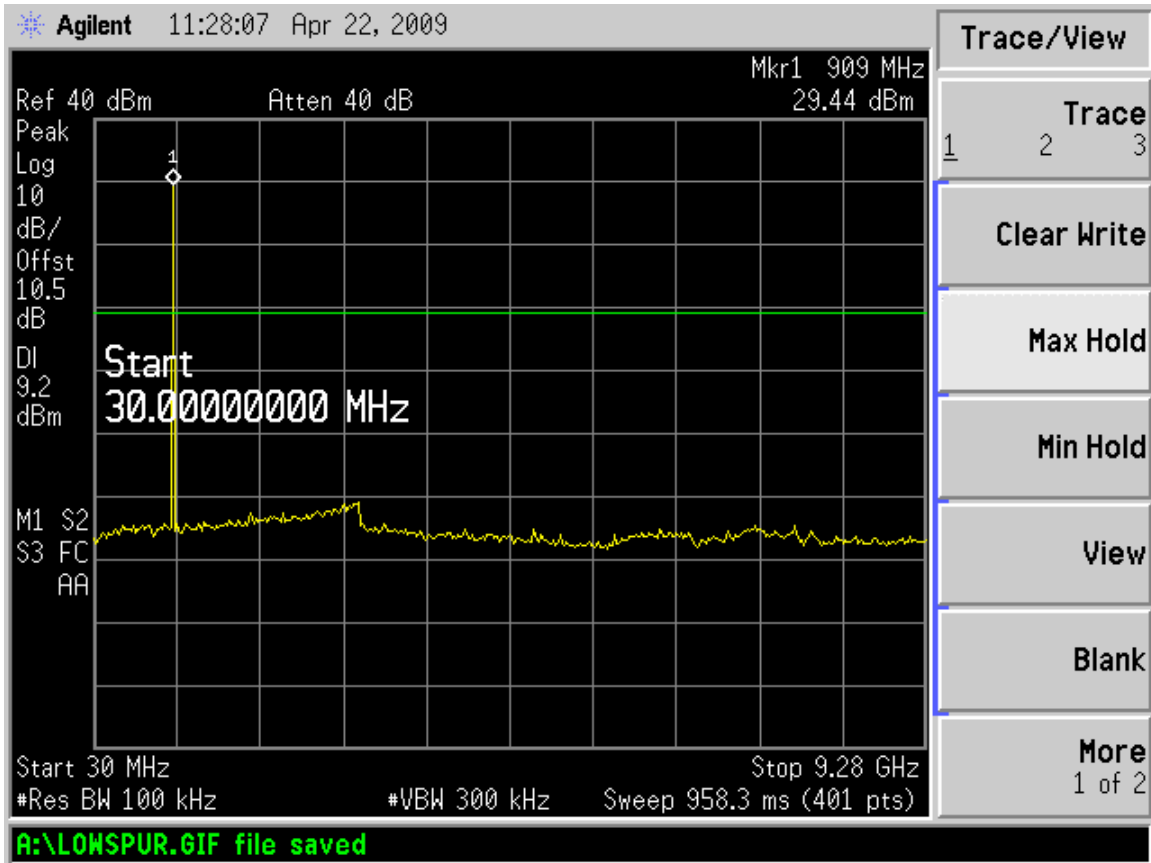

SPURIOUS EMISSIONS, HIGH CHANNEL, HOPPING

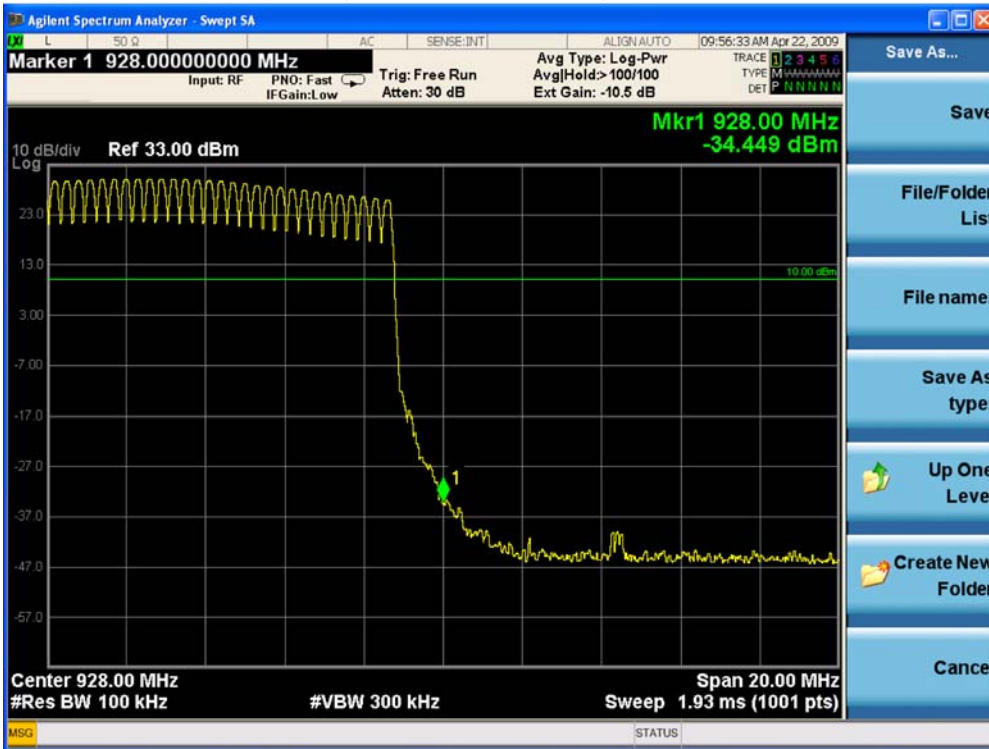

SPURIOUS EMISSIONS, HIGH CHANNEL, HOPPING

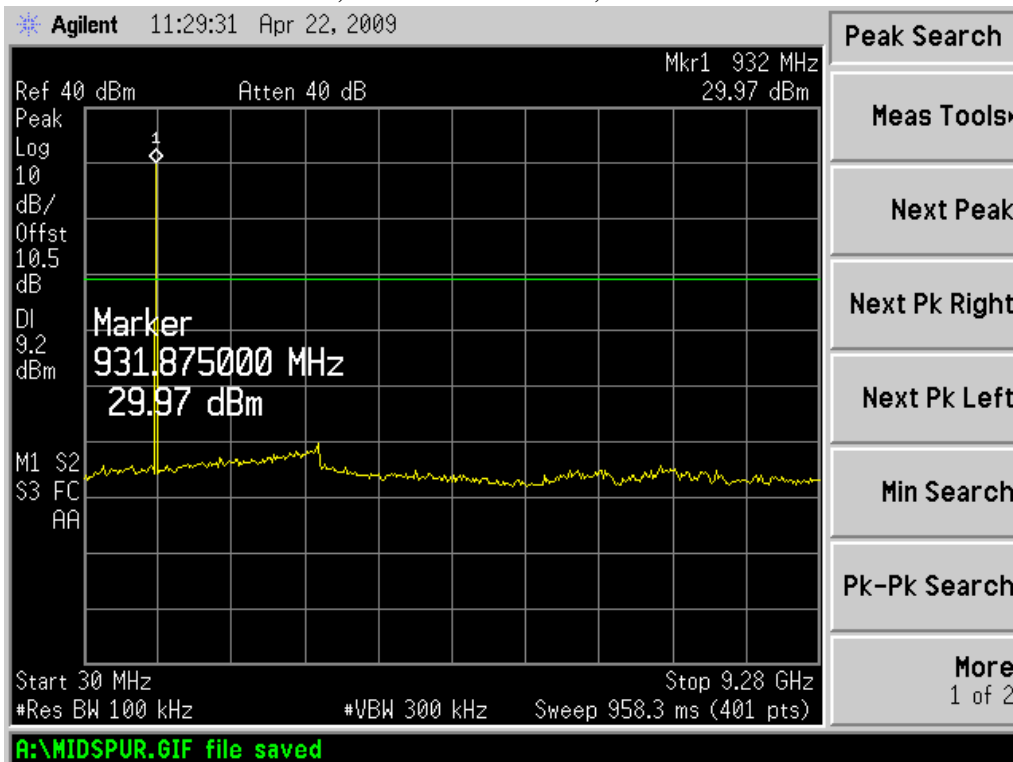

4.4 POWERLINE CONDUCTED EMISSIONS

LIMIT

§15.207 (a) Except as shown in paragraphs (b) and (c) of this section, for an intentional radiator that is designed to be connected to the public utility (AC) power line, the radio frequency voltage that is conducted back onto the AC power line on any frequency or frequencies within the band 150 kHz to 30 MHz shall not exceed the limits in the following table, as measured using a 50 μ H/50 ohms line impedance stabilization network (LISN). Compliance with the provisions of this paragraph shall be based on the measurement of the radio frequency voltage between each power line and ground at the power terminal.

TEST NOT REQUIRED. EUT is battery powered only.

SETUP PHOTOS

ANTENNA PORT CONDUCTED RF MEASUREMENT SETUP, SILVER SPRING NETWORKS

Photo Not Available

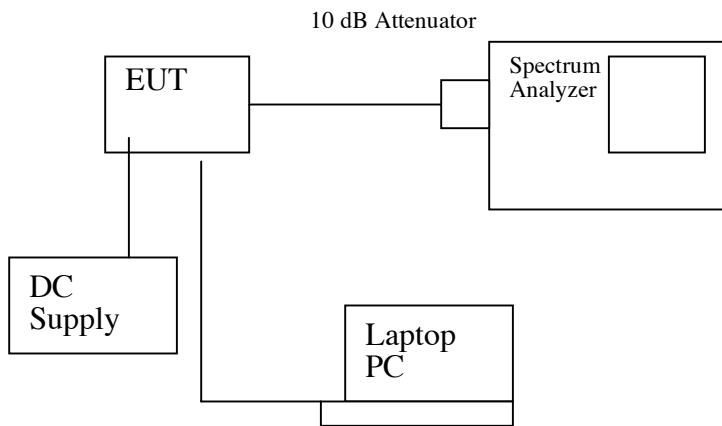

RADIATED RF MEASUREMENT SETUP

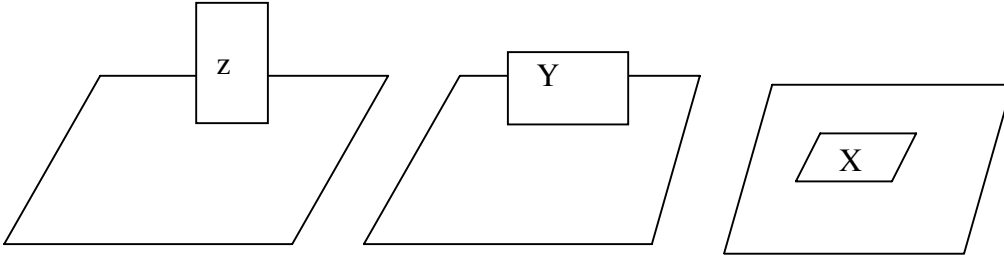

Radiated Emissions Test Setup, Worst-case Orientation (“Y” orientation)

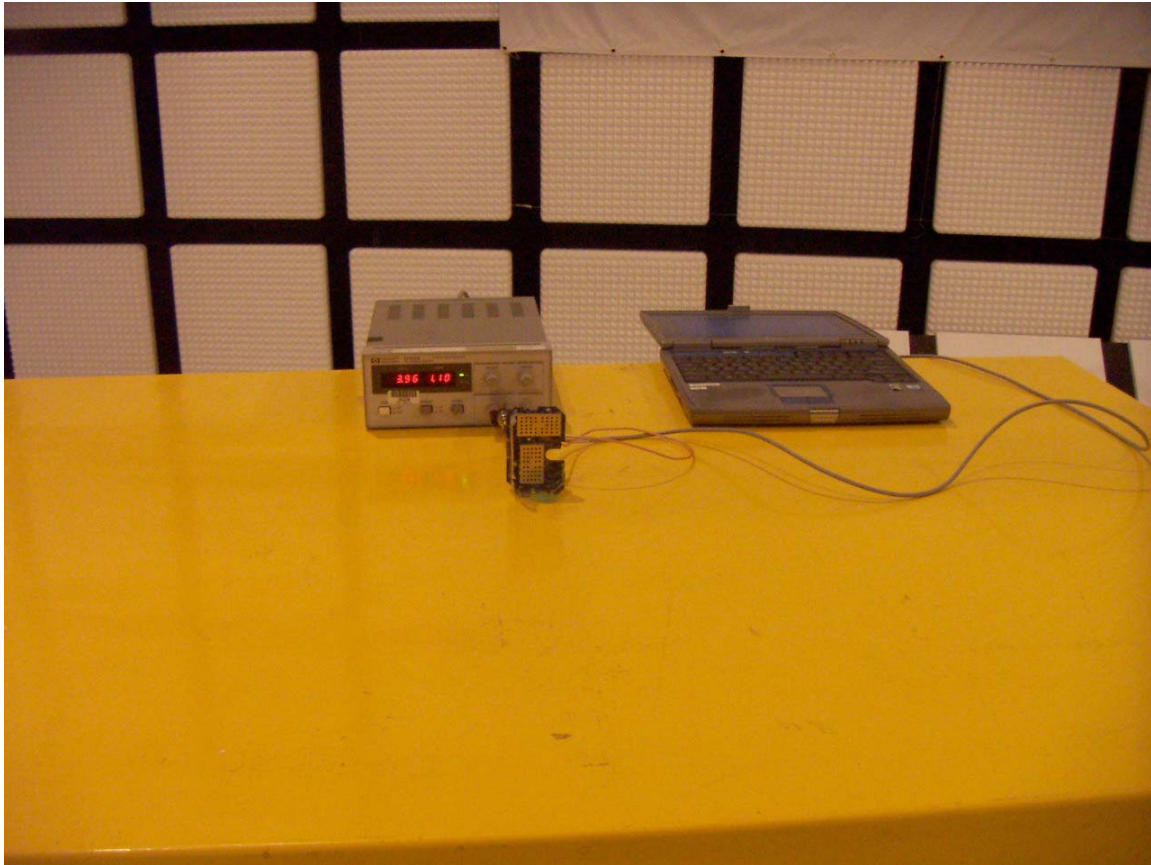

END OF REPORT

Report Revision History

Revision No.	Revision Description	Pages Revised	Revised by	Date
-	Original Issue		T. Cokenias	5/13/09
1	Add fundamental emission plots for -20 dBc calculation at 100 kHz BW	7	T. Cokenias	5/13/09
	Replace hopping frequency duration plots with more accurate ones	18,19		
	Add horn antenna information	3		