

Test of: Silver Spring Networks NIC 451

To: CISPR 22 / ICES-003 / FCC Part 15B
Emissions

Test Report Serial No.: SSNT92-U8 Rev A



Report

from



Test of Silver Spring Networks NIC 451

To CISPR 22 / ICES-003 / FCC Part 15B Emissions

Test Report Serial No.: SSNT92-U8 Rev A

This report supersedes NONE

Manufacturer: Silver Spring Networks
555 Broadway Street
Redwood City
California 94063, USA

Product Function: Machine to machine communication

Copy No: pdf **Issue Date:** 16th April 2015

This Test Report is Issued Under the Authority of:

MiCOM Labs, Inc.
575 Boulder Court
Pleasanton, CA 94566 USA
Phone: +1 (925) 462-0304
Fax: +1 (925) 462-0306
www.micomlabs.com



MiCOM Labs is an ISO 17025 Accredited Testing Laboratory



Title: Silver Spring Networks NIC 451
To: CISPR 22 / ICES-003 / FCC Part 15B Emissions
Serial #: SSNT92-U8 Rev A
Issue Date: 16th April 2015
Page: 3 of 31

This page has been left intentionally blank

This test report may be reproduced in full only. The document may only be updated by MiCOM Labs personnel and any changes noted in the Document History section of the report.



TABLE OF CONTENTS

ACCREDITATION, LISTINGS & RECOGNITION	5
1. TESTING ACCREDITATION.....	5
2. RECOGNITION.....	6
3. PRODUCT CERTIFICATION	7
1. TEST RESULT CERTIFICATE	9
2. REFERENCES AND MEASUREMENT UNCERTAINTY	10
2.1. Normative References	10
2.2. Test and Uncertainty Procedures.....	11
3. PRODUCT DETAILS AND TEST CONFIGURATIONS	12
3.1. Technical Details.....	12
3.2. Scope of Test Program	13
3.3. Product Description.....	15
3.4. Equipment Model(s) and Serial Number(s).....	16
3.5. Antenna Details.....	16
3.6. Cabling and I/O Ports.....	16
3.7. Equipment Modifications	16
3.8. Deviations from the Test Standard	16
4. TEST SUMMARY / SETUP.....	17
5. TEST RESULTS.....	18
5.1. Radiated Spurious Emissions – Digital Apparatus.....	18
5.2. AC Mains Conducted Emissions	24
5.3. Conducted Emission - Telecommunication Ports	27
6. PHOTOGRAPH.....	28
7. TEST EQUIPMENT DETAILS	30

This test report may be reproduced in full only. The document may only be updated by MiCOM Labs personnel and any changes noted in the Document History section of the report.

ACCREDITATION, LISTINGS & RECOGNITION

1. TESTING ACCREDITATION

MiCOM Labs, Inc. an accredited laboratory complies with the international standard ISO/IEC 17025. The company is accredited by the American Association for Laboratory Accreditation (A2LA) www.a2la.org test laboratory number 2381.01. MiCOM Labs test schedule is available at the following URL; <http://www.a2la.org/scopepdf/2381-01.pdf>



American Association for Laboratory Accreditation

Accredited Laboratory

A2LA has accredited

MICOM LABS

Pleasanton, CA

for technical competence in the field of

Electrical Testing

This laboratory is accredited in accordance with the recognized International Standard ISO/IEC 17025:2005 *General Requirements for the Competence of Testing and Calibration Laboratories*. This accreditation demonstrates technical competence for a defined scope and the operation of a laboratory quality management system (*refer to joint ISO-ILAC-IAF Communiqué dated 8 January 2009*).

Presented this 28th day of February 2014.



President & CEO
For the Accreditation Council
Certificate Number 2381.01
Valid to November 30, 2015



For the tests or types of tests to which this accreditation applies, please refer to the laboratory's Electrical Scope of Accreditation.

This test report may be reproduced in full only. The document may only be updated by MiCOM Labs personnel and any changes noted in the Document History section of the report.



2. RECOGNITION

MiCOM Labs, Inc has widely recognized Electrical testing capabilities. Our international recognition includes Conformity Assessment Body designation by APEC MRA** countries. Our test reports are widely accepted for global type approvals.

Country	Recognition Body	Status	Phase	Identification No.
model	Federal Communications Commission (FCC)	TCB	-	US0159 Listing #: 102167
Canada	Industry Canada (IC)	FCB	APEC MRA 2	US0159 Listing #: 4143A-2 4143A-3
Japan	MIC (Ministry of Internal Affairs and Communication)	CAB	APEC MRA 2	RCB 210
	VCCI	--	--	A-0012
Europe	European Commission	NB	EU MRA	NB 2280
Australia	Australian Communications and Media Authority (ACMA)	CAB	APEC MRA 1	US0159
Hong Kong	Office of the Telecommunication Authority (OFTA)	CAB	APEC MRA 1	
Korea	Ministry of Information and Communication Radio Research Laboratory (RRL)	CAB	APEC MRA 1	
Singapore	Infocomm Development Authority (IDA)	CAB	APEC MRA 1	
Taiwan	National Communications Commission (NCC) Bureau of Standards, Metrology and Inspection (BSMI)	CAB	APEC MRA 1	
Vietnam	Ministry of Communication (MIC)	CAB	APEC MRA 1	

**APEC MRA – Asia Pacific Economic Community Mutual Recognition Agreement.

Is a recognition agreement under which test lab is accredited to regulatory standards of the APEC member countries.

Phase I - recognition for product testing

Phase II – recognition for both product testing and certification

N/A – Not Applicable

**EU MRA – European Union Mutual Recognition Agreement.

Is a recognition agreement under which test lab is accredited to regulatory standards of the EU member countries.

**NB – Notified Body

This test report may be reproduced in full only. The document may only be updated by MiCOM Labs personnel and any changes noted in the Document History section of the report.

3. PRODUCT CERTIFICATION

MiCOM Labs, Inc. is an accredited Product Certification Body per the international standard ISO/IEC 17065. The company is accredited by the American Association for Laboratory Accreditation (A2LA) www.a2la.org test laboratory number 2381.02. MiCOM Labs test schedule is available at the following URL; <http://www.a2la.org/scopepdf/2381-02.pdf>



American Association for Laboratory Accreditation

Accredited Product Certification Body

A2LA has accredited

MICOM LABS

Pleasanton, CA

for technical competence as a

Product Certification Body

This product certification body is accredited in accordance with the recognized International Standard ISO/IEC 17065:2012 - *Requirements for bodies certifying products, processes and services*. This accreditation demonstrates technical competence for a defined scope and the operation of a quality management system.

Presented this 28th day of February 2014.



President & CEO
For the Accreditation Council
Certificate Number 2381.02
Valid to November 30, 2015



For the product certification schemes to which this accreditation applies, please refer to the organization's Product Certification Scope of Accreditation

United States of America – Telecommunication Certification Body (TCB)

TCB Identifier – US0159

Industry Canada – Certification Body

CAB Identifier – US0159

Europe – Notified Body

Notified Body Identifier - 2280

Japan – Recognized Certification Body (RCB)

RCB Identifier – 210

This test report may be reproduced in full only. The document may only be updated by MiCOM Labs personnel and any changes noted in the Document History section of the report.



Title: Silver Spring Networks NIC 451
To: CISPR 22 / ICES-003 / FCC Part 15B Emissions
Serial #: SSNT92-U8 Rev A
Issue Date: 16th April 2015
Page: 8 of 31

DOCUMENT HISTORY

Document History		
Revision	Date	Comments
Draft		
Rev A	16 th April 2015	Initial release.

This test report may be reproduced in full only. The document may only be updated by MiCOM Labs personnel and any changes noted in the Document History section of the report.



Title: Silver Spring Networks NIC 451
To: CISPR 22 / ICES-003 / FCC Part 15B Emissions
Serial #: SSNT92-U8 Rev A
Issue Date: 16th April 2015
Page: 9 of 31

1. TEST RESULT CERTIFICATE

Manufacturer:	Silver Spring Networks 555 Broadway Street Redwood City California 94063, USA	Tested By:	MiCOM Labs, Inc. 575 Boulder Court, Pleasanton California, 94566, USA
EUT	Network Interface Card (NIC)	Tel:	+1 925 462 0304
Model:	NIC 451-0523-10	Fax:	+1 925 462 0306
S/N	00:13:50:07:00:00:03:CD		
Test Date(s):	18th March 2015	Website:	www.micomlabs.com

STANDARD(S)	TEST RESULTS
CISPR 22 / ICES-003 / FCC Part 15B Emissions.	EQUIPMENT COMPLIES

MiCOM Labs, Inc. tested the equipment mentioned in accordance with the requirements set forth in the above standards. Test results indicate that the equipment tested is capable of demonstrating compliance with the requirements as documented within this report.

Notes:

1. This document reports conditions under which testing was conducted and the results of testing performed.
2. Details of test methods used have been recorded and kept on file by the laboratory.
3. Test results apply only to the item(s) tested.

Approved & Released for MiCOM Labs, Inc. by:



TESTING CERT #2381.01

Graeme Grieve
Quality Manager MiCOM Labs, Inc.

Gordon Hurst
President & CEO MiCOM Labs, Inc.

This test report may be reproduced in full only. The document may only be updated by MiCOM Labs personnel and any changes noted in the Document History section of the report.

2. REFERENCES AND MEASUREMENT UNCERTAINTY

2.1. Normative References

REF.	PUBLICATION	YEAR	TITLE
i.	FCC 47 CFR Part 15, Subpart B	2012	Title 47 CFR Part 15, SubPart B; Unintentional Radiators
ii.	ICES-003	2012	Information Technology Equipment (ITE) – Limits and methods of measurement.
iii.	RSS-GEN	2010	Radio Standards Specification-Gen, Issue 3, General Requirements and Information for the Certification of Radiocommunication Equipment
iv.	ANSI C63.4	2014	American National Standards for Methods of Measurement of Radio-Noise Emissions from Low-Voltage Electrical and Electronic Equipment in the Range of 9 kHz to 40 GHz
v.	CISPR 22	2008	Information technology equipment - Radio disturbance characteristics - Limits and methods of measurement
vi.	M 3003	Edition 3 Nov Dec. 2012	Expression of Uncertainty and Confidence in Measurements
vii.	LAB34	Edition 1 Aug 2002	The expression of uncertainty in EMC Testing
viii.	ETSI TR 100 028	2001	Parts 1 and 2 Electromagnetic compatibility and Radio Spectrum Matters (ERM); Uncertainties in the measurement of mobile radio equipment characteristics
ix.	A2LA	April 2014	Reference to A2LA Accreditation Status – A2LA Advertising Policy



Title: Silver Spring Networks NIC 451
To: CISPR 22 / ICES-003 / FCC Part 15B Emissions
Serial #: SSNT92-U8 Rev A
Issue Date: 16th April 2015
Page: 11 of 31

2.2. Test and Uncertainty Procedures

Conducted and radiated emission measurements were conducted in accordance with American National Standards Institute ANSI C63.4, listed in the Normative References section of this report.

Measurement uncertainty figures are calculated in accordance with ETSI TR 100 028 Parts 1 and 2.

Measurement uncertainties stated are based on a standard uncertainty multiplied by a coverage factor $k = 2$, providing a level of confidence of approximately 95 % in accordance with UKAS document M 3003 listed in the Normative References section of this report.

This test report may be reproduced in full only. The document may only be updated by MiCOM Labs personnel and any changes noted in the Document History section of the report.



Title: Silver Spring Networks NIC 451
To: CISPR 22 / ICES-003 / FCC Part 15B Emissions
Serial #: SSNT92-U8 Rev A
Issue Date: 16th April 2015
Page: 12 of 31

3. PRODUCT DETAILS AND TEST CONFIGURATIONS

3.1. Technical Details

Details	Description
Purpose:	Testing of the Silver Spring Networks NIC 451 to CISPR 22 / ICES-003 / FCC Part 15B Emissions regulations.
Applicant:	As Manufacturer
Manufacturer:	Silver Spring Networks 555 Broadway Street Redwood City California 94063, USA
Laboratory performing the tests:	MiCOM Labs, Inc. 575 Boulder Court Pleasanton, California 94566 USA
Test report reference number:	SSNT92-U8 Rev A
Date EUT received:	14th March 2015
Dates of test (from - to):	18th March 2015
Standard(s) applied:	CISPR 22 / ICES-003 / FCC Part 15B Emissions;
No of Units Tested:	One
Type of Equipment:	Network Interface Card (NIC)
Manufacturers Trade Name:	Silver Spring Networks NIC 451
Model:	NIC 451-0523-10
Serial Number	00:13:50:07:00:00:03:CD
Firmware Revision	3.8.2
Hardware revision	174-0595-00
Internal Clocks	26 MHz, 32.768 kHz
Construction/Location for Use:	Indoor/Outdoor
Operating Temperature Range °C:	-40°C to +85°C (client declared range)
Rated Supply Voltage and Current	4 Vdc (Battery)
Equipment Dimensions:	2.75" diameter by 0.75" high
Weight:	50 grams
Primary Function:	Machine to machine communication over 900 MHz FHSS

This test report may be reproduced in full only. The document may only be updated by MiCOM Labs personnel and any changes noted in the Document History section of the report.

3.2. Scope of Test Program

The scope of the test program was to test the Silver Spring Networks NIC 451 to verify compliance with the emissions requirements of CISPR 22 / ICES-003 / FCC Part 15B Emissions.

Product Description

The following product description was provided by the manufacturer.

The Silver Spring Networks NIC 451 is a network interface card (NIC) designed to fit inside existing photocell products as a retrofit to provide communication and control for street lights. The NIC 451 is designed to be integrated into LED fixtures and control nodes, and provides advanced functionality for controlling external devices such as dimmable electronic ballasts and LED fixtures. The NIC uses industry standard interfaces (such as 1-10V or DALI) to control these devices. An optional GPS chip can be added to provide accurate location and time and/or real-time clock (RTC) can be provided with backup battery/super caps to keep time, even when the NIC has lost power.

Silver Spring Networks NIC 451 (Top)

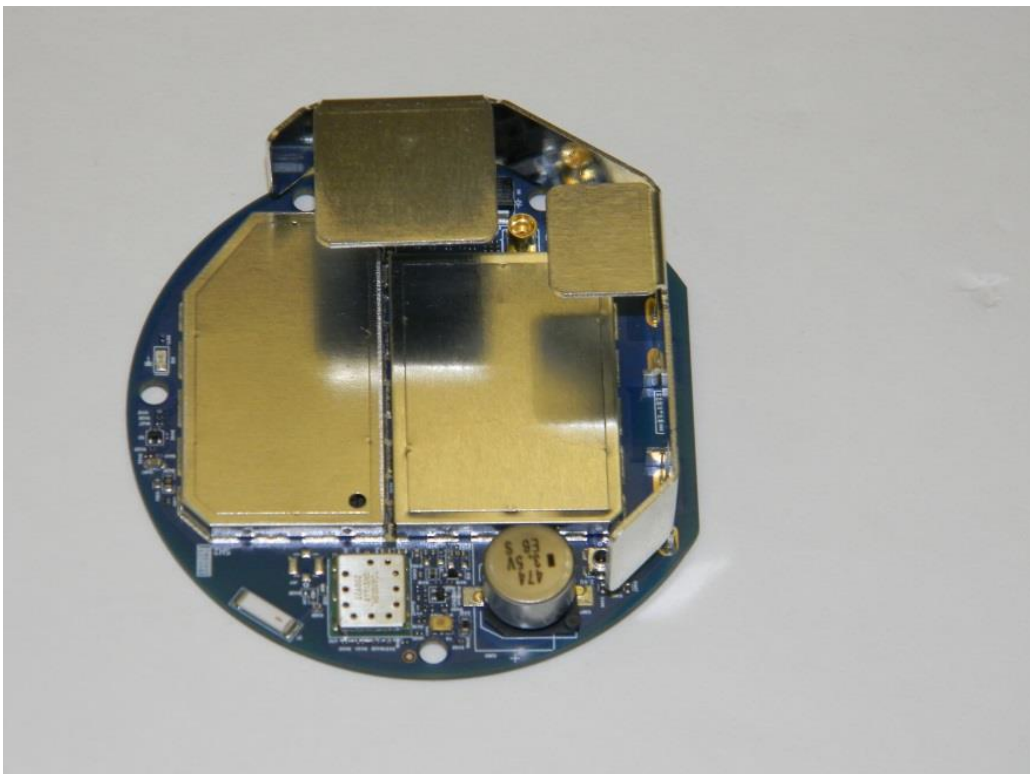

Silver Spring Networks NIC 451 (Back)





3.3. Product Description

The following product model information was declared by the manufacturer.

The manufacturer declared that the variant tested in the 2400 – 2483.5 MHz range represents the worst case covering all of the available options.

Models	FCC ID	IC ID	900MHz Mesh	2.4GHz Mesh	Int Ant	Ext Ant	GPS	RTC	1-10V Dimmer
NIC 451-0101	OWS-NIC451	5975A-NIC451	X		X				
NIC 451-0102	OWS-NIC451	5975A-NIC451	X			X			
NIC 451-0103	OWS-NIC451	5975A-NIC451	X		X	X			
NIC 451-0501	OWS-NIC452	5975A-NIC452	X	X	X				
NIC 451-0502	OWS-NIC452	5975A-NIC452	X	X		X			
NIC 451-0503	OWS-NIC452	5975A-NIC452	X	X	X	X			
NIC 451-0103-03	OWS-NIC451	5975A-NIC451	X		X	X		X	
NIC 451-0103-04	OWS-NIC451	5975A-NIC451	X		X	X		X	X
NIC 451-0101-03	OWS-NIC451	5975A-NIC451	X		X			X	
NIC 451-0102-03	OWS-NIC451	5975A-NIC451	X			X		X	
NIC 451-0503-03	OWS-NIC452	5975A-NIC452	X	X	X	X		X	
NIC 451-0121-05	OWS-NIC451	5975A-NIC451	X		X		X		
NIC 451-0123-05	OWS-NIC451	5975A-NIC451	X		X	X	X		
NIC 451-0523-05	OWS-NIC452	5975A-NIC452	X	X	X	X	X		
NIC 451-0523-10	OWS-NIC452	5975A-NIC452	X	X	X	X	X	X	X

This test report may be reproduced in full only. The document may only be updated by MiCOM Labs personnel and any changes noted in the Document History section of the report.



3.4. Equipment Model(s) and Serial Number(s)

Type (EUT/Support)	Equipment Description (Including Brand Name)	Mfr	Model No.	Serial No.
EUT	Network Interface Card	Silver Spring Network	NIC 451-0523-10	00:13:50:07:00:00:03:CD
Support	Laptop	IBM	ThinkPad	None

3.5. Antenna Details

1. No antenna testing performed as part of this test program.

3.6. Cabling and I/O Ports

1. None.

3.7. Equipment Modifications

The following modifications were required to bring the equipment into compliance:

1. None.

3.8. Deviations from the Test Standard

The following deviations from the test standard were required in order to complete the test program:

1. None.



4. TEST SUMMARY / SETUP

List of Measurements

The following table represent the common list of emission measurements required under CISPR 22, ICES-003 and FCC Part 15B standards;

TABLE OF REQUIRED TESTS – Emissions

Test Standard	Phenomenon/ Description	Limits	Compliance
CISPR22/ ICES-003 / FCC Part 15B	Radiated Emissions	Class B	Complies
CISPR22/ ICES-003 / FCC Part 15B	Conducted Emissions - ac power line	Class B	Not Required
CISPR22/ ICES-003	Conducted Emission - Telecommunication Port	Class B	Not Required

Note 1: Test results reported in this document relate only to the items tested

Note 2: *The required tests demonstrated compliance as per client declaration of test configuration, monitoring methodology and associated pass/fail criteria*

Note 3: *Section 3.6 Equipment Modifications highlights the equipment modifications that were required to bring the product into compliance with the above test matrix*



Title: Silver Spring Networks NIC 451
To: CISPR 22 / ICES-003 / FCC Part 15B Emissions
Serial #: SSNT92-U8 Rev A
Issue Date: 16th April 2015
Page: 18 of 31

5. TEST RESULTS

5.1. Radiated Spurious Emissions – Digital Apparatus

Test Procedure

Testing 30 – 1,000 MHz was performed in a anechoic chamber using a CISPR compliant receiver. Preliminary radiated emissions were measured on every azimuth and with the receiving antenna in both horizontal and vertical polarizations. To further maximize emissions the receive antenna was varied between 1 and 4 meters. The emissions are recorded with receiver in peak hold mode.

Emissions nearest the limits were chosen for maximization and formal measurement using a CISPR Compliant receiver. Emissions from 30 MHz – 1000 MHz are measured utilizing a CISPR compliant quasi-peak detector with a tuned receiver, using a bandwidth of 120 kHz. Emissions above 1000 MHz are measured utilizing a CISPR compliant average detector with a tuned receiver, using a bandwidth of 1 MHz. Only the highest emissions relative to the limit are listed.

This test report may be reproduced in full only. The document may only be updated by MiCOM Labs personnel and any changes noted in the Document History section of the report.

Radiated Emission Measurement Setup – Below 1 GHz

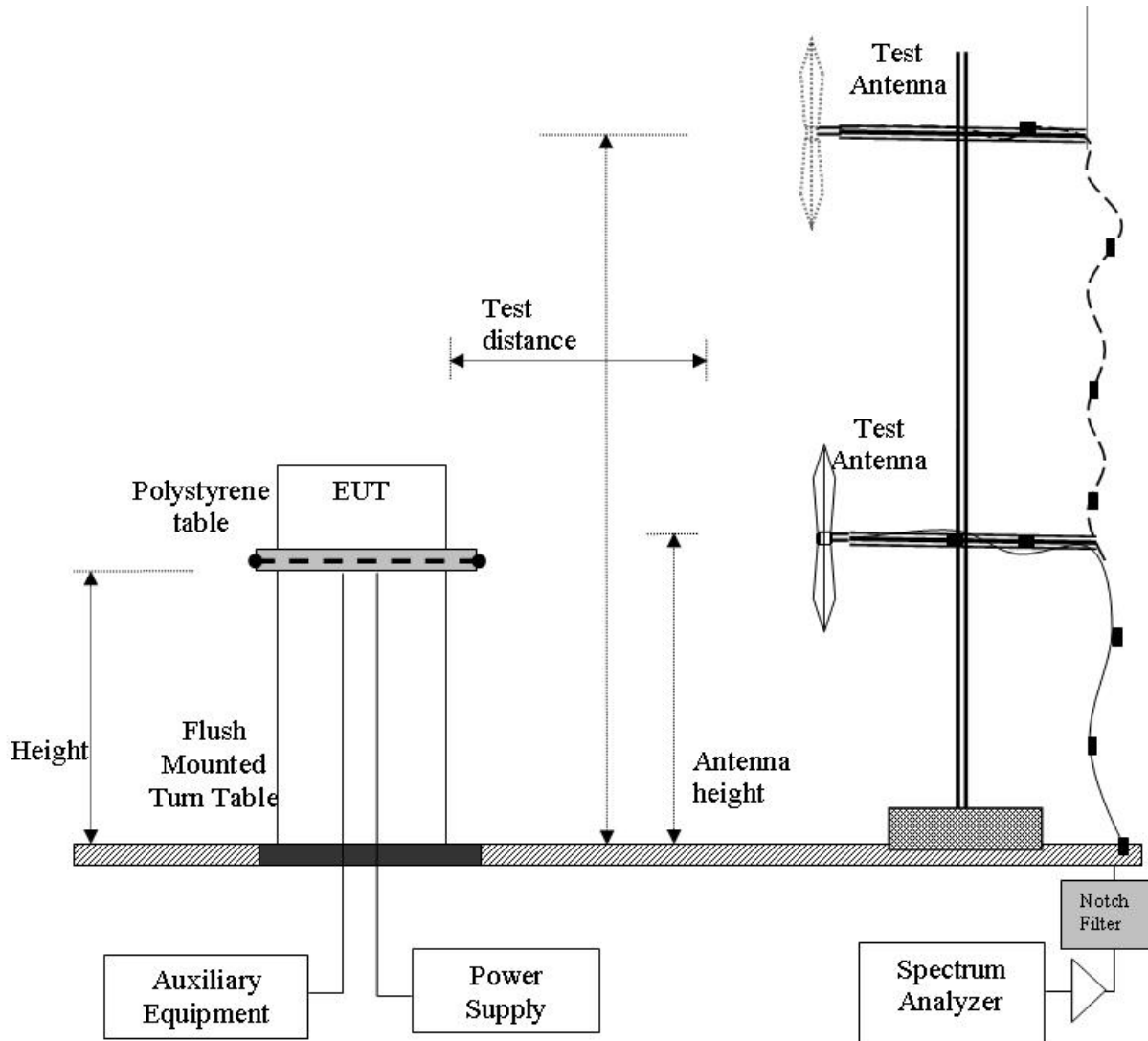

This test report may be reproduced in full only. The document may only be updated by MiCOM Labs personnel and any changes noted in the Document History section of the report.



Field Strength Calculation

The field strength is calculated by adding the Antenna Factor and Cable Loss, and subtracting Amplifier Gain from the measured reading. All factors are included in the reported data.

$$FS = R + AF + CORR - FO$$

FS = Field Strength
R = Measured Spectrum analyzer Input Amplitude
AF = Antenna Factor

$$CORR = \text{Correction Factor} = CL - AG + NFL$$

CL = Cable Loss
AG = Amplifier Gain
FO = Distance Falloff Factor
NFL = Notch Filter Loss or Waveguide Loss

Field Strength Calculation Example:

Given receiver input reading of 51.5 dB μ V; Antenna Factor of 8.5 dB; Cable Loss of 1.3 dB; Falloff Factor of 0 dB, an Amplifier Gain of 26 dB and Notch Filter Loss of 1 dB. The Field Strength of the measured emission is:

$$FS = 51.5 + 8.5 + 1.3 - 26.0 + 1 = 36.3 \text{ dB}\mu\text{V/m}$$

Conversion between dB μ V/m (or dB μ V) and μ V/m (or μ V) are done as:

$$\text{Level (dB}\mu\text{V/m)} = 20 * \text{Log (level (\mu\text{V/m}))}$$

$$40 \text{ dB}\mu\text{V/m} = 100 \mu\text{V/m}$$

$$48 \text{ dB}\mu\text{V/m} = 250 \mu\text{V/m}$$



Spurious Emissions Limits

EN 55022 / CISPR 22: Spurious Emissions Limits

Limits below 1GHz:

Class A limits

Frequency(MHz)	Quasi-peak Limit (dB μ V/m)	Measurement Distance (meters)		Quasi-peak Limit (dB μ V/m)	Measurement Distance (meters)
30 to 230	40	10		50.5	3
230 to 1 000	47	10		57.5	3

Class B limits

Frequency(MHz)	Quasi-peak Limit (dB μ V/m)	Measurement Distance (meters)		Quasi-peak Limit (dB μ V/m)	Measurement Distance (meters)
30 to 230	30	10		40.5	3
230 to 1 000	37	10		47.5	3

NOTE: The lower limit applies at the transition frequency.

Laboratory Measurement Uncertainty for Spectrum Measurement

Measurement Uncertainty	+5.6/ -4.5 dB
--------------------------------	---------------

Traceability

Method	Test Equipment Used
Work instruction WI-03	0088, 0158, 0134, 0304, 0311, 0315, 0310, 0312

This test report may be reproduced in full only. The document may only be updated by MiCOM Labs personnel and any changes noted in the Document History section of the report.



Measurement Results: Radiated Emissions; 30-1000MHz,

The highest frequency of the internal sources of the EUT is less than 108 MHz, no emissions measurements required above 1 GHz.

Integral Antenna

EUT	NIC 451-0523-10	Engineer	JMH
Variant	Digital Emissions	Temp (°C)	18
Freq. Range	30 MHz - 1000 MHz	Rel. Hum.(%)	43
Standard Limit	CISPR Class B	Press. (mBars)	1005
Support Equip	None		
Test Notes	MAC: 00:13:50:07:00:00:03:CD, INT Antenna WPANT10061-S1C, GPS ON		

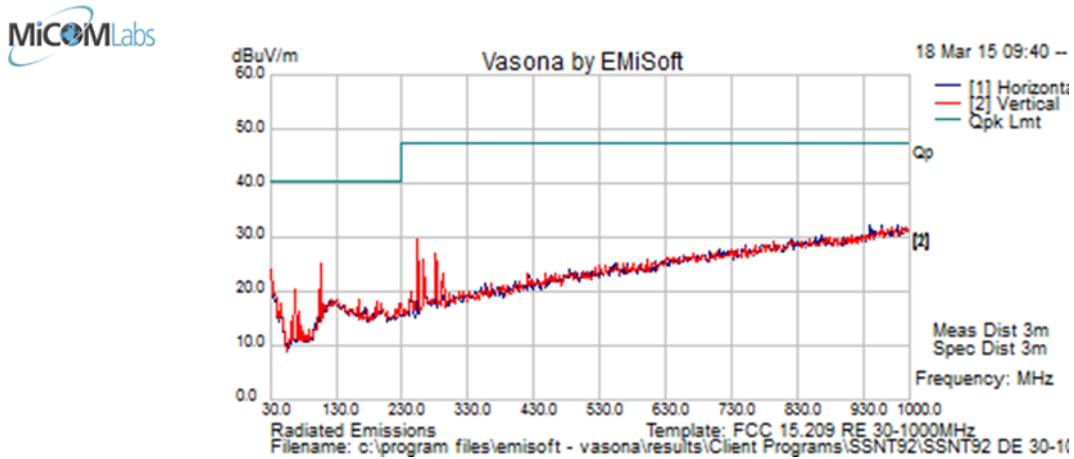

Formally measured emission peaks

Frequency MHz	Raw dBuV	Cable Loss	AF dB	Level dBuV/m	Measurement Type	Pol	Hgt cm	Azt Deg	Limit dBuV/m	Margin dB	Pass /Fail	Comments
253.538	44.2	4.5	-19.0	29.740	Peak [Scan]	H	99	57	47.5	-17.8	Pass	

Legend: DIG = Digital Device Emission; TX = Transmitter Emission; FUND = Fundamental Frequency
 TRNS= Transient Emission, Brbnd= Broadband emission

This test report may be reproduced in full only. The document may only be updated by MiCOM Labs personnel and any changes noted in the Document History section of the report.



Title: Silver Spring Networks NIC 451
To: CISPR 22 / ICES-003 / FCC Part 15B Emissions
Serial #: SSNT92-U8 Rev A
Issue Date: 16th April 2015
Page: 23 of 31

External Antenna

EUT	NIC 451-0523-10	Engineer	JMH
Variant	Digital Emissions	Temp (°C)	18
Freq. Range	30 MHz - 1000 MHz	Rel. Hum.(%)	43
Standard Limit	CISPR Class B	Press. (mBars)	1005
Support Equip	None		
Test Notes	MAC: 00:13:50:07:00:00:03:CD, EXT Antenna WPANT30088-S1A, GPS ON		

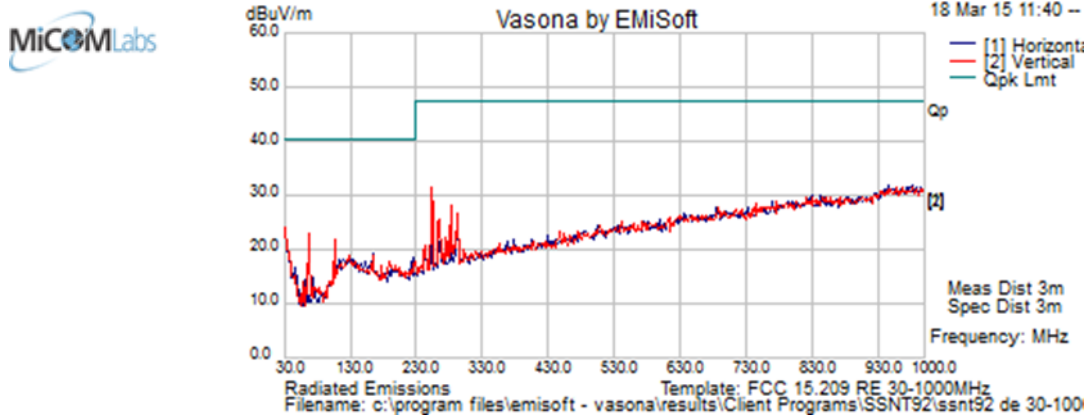

Formally measured emission peaks

Frequency MHz	Raw dBuV	Cable Loss	AF dB	Level dBuV/m	Measurement Type	Pol	Hgt cm	Azt Deg	Limit dBuV/m	Margin dB	Pass /Fail	Comments
253.701	0.0	0.0	0.0	31.150	Peak [Scan]	H	0	0	47.5	-16.4	Pass	
Legend: DIG = Digital Device Emission; TX = Transmitter Emission; FUND = Fundamental Frequency TRNS= Transient Emission, Brbnd= Broadband emission												

This test report may be reproduced in full only. The document may only be updated by MiCOM Labs personnel and any changes noted in the Document History section of the report.

5.2. AC Mains Conducted Emissions

Not Required EUT has no AC Power Input.

Scope

This test assesses the ability of the EUT to limit its internal noise from being present on the AC mains power input/output ports.

Test Procedure

The EUT is configured in accordance with ANSI C63.4. The conducted emissions are measured in a shielded room with a spectrum analyzer in peak hold in the first instance. Emissions closest to the limit are measured in the quasi-peak mode (QP) with the tuned receiver using a bandwidth of 9 kHz. The emissions are maximized further by cable manipulation. The highest emissions relative to the limit are listed.

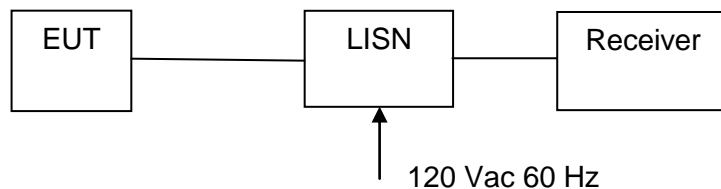

Measurement Setup for Conducted Emissions Test



Limits

Limits for conducted disturbance at the mains ports of class B ITE

Frequency of emission (MHz)	Quasi-peak dBuV	Average dBuV
0.15–0.5	66 to 56*	56 to 46*
0.5–5	56	46
5–30	60	50
Note 1	* Decreases with the logarithm of the frequency	
Note 2	* The lower limit applies at the boundary between frequency ranges	

Limits for conducted disturbance at the mains ports of class A ITE

Frequency of emission (MHz)	Quasi-peak dBuV	Average dBuV
0.15–0.5	79	66
0.5–30	73	60
Note 1	* The lower limit shall apply at the transition frequency.	

Traceability

All conducted emission measurements are traceable to national standards. The uncertainty of measurement at a confidence level of not less than 95 %, with a coverage factor of $k=2$, in the range 9 kHz – 30 MHz (Average & Quasi-peak) is ± 2.64 dB.

Laboratory Measurement Uncertainty	
Measurement uncertainty	± 2.64 dB

Method	Test Equipment Used
Measurements were made per work instruction WI-EMC-01 'Measurement of Conducted Emissions'	0158, 0184, 0193, 0190, 0293, 0307, 156, 193, 190



Title: Silver Spring Networks NIC 451
To: CISPR 22 / ICES-003 / FCC Part 15B Emissions
Serial #: SSNT92-U8 Rev A
Issue Date: 16th April 2015
Page: 26 of 31

Measurement Results

Not Applicable- EUT is dc powered by host device.

This test report may be reproduced in full only. The document may only be updated by MiCOM Labs personnel and any changes noted in the Document History section of the report.

5.3. Conducted Emission - Telecommunication Ports

Not Required. EUT does not have cables connecting to the PSTN.

Scope

This test assesses the EUT unwanted emission present at the telecommunication ports.

Test Method

The test method shall be in accordance with EN 55022.

The measurement frequency range extends from 150 kHz to 30 MHz. When the EUT is a transmitter operating at frequencies below 30 MHz, then the exclusion band for transmitters applies for measurements in the transmit mode of operation.

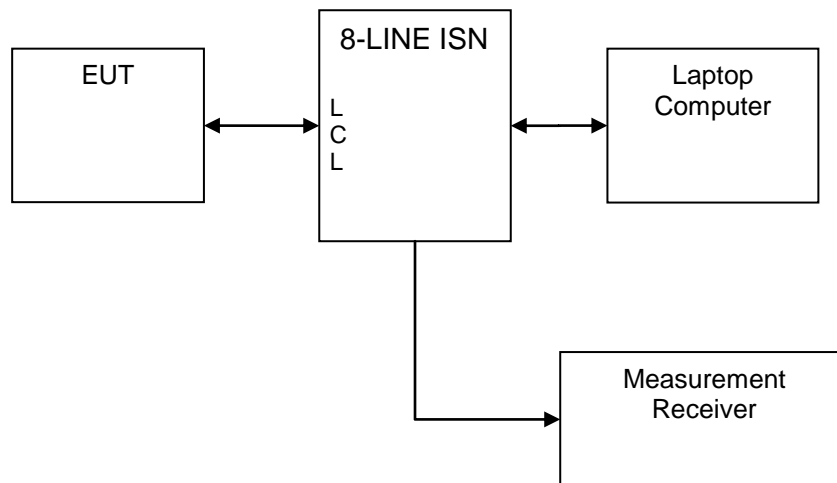

Measurement set up for Conducted Emissions Test

Limits:

The telecommunication ports shall meet the class B limits given in EN 55022. Alternatively, for equipment intended to be used in telecommunication centers only, the class A limits given in EN 55022 may be used.

6. PHOTOGRAPH

Radiated Emissions Setup – Front

EUT with External Antenna

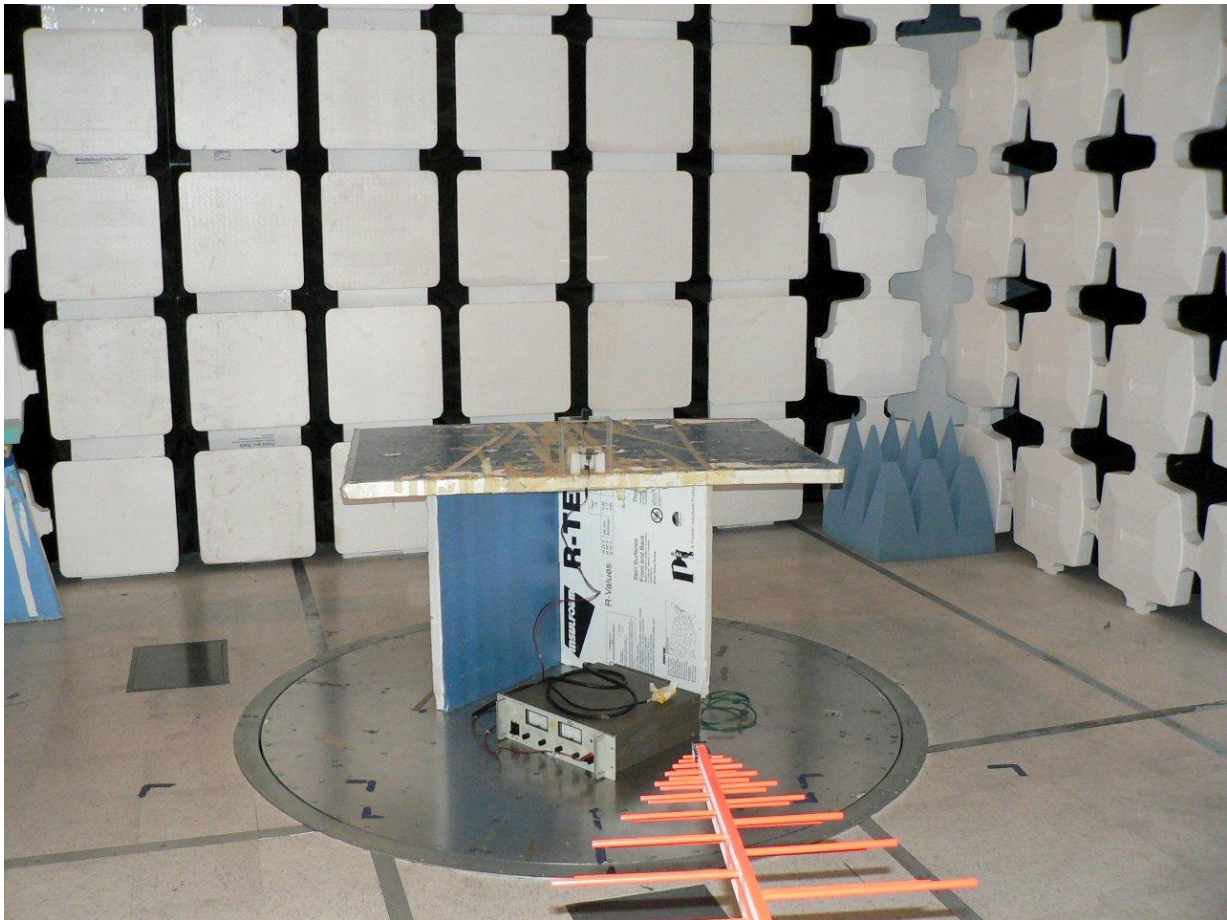

This test report may be reproduced in full only. The document may only be updated by MiCOM Labs personnel and any changes noted in the Document History section of the report.

Radiated Emissions Setup – Back

EUT with External Antenna

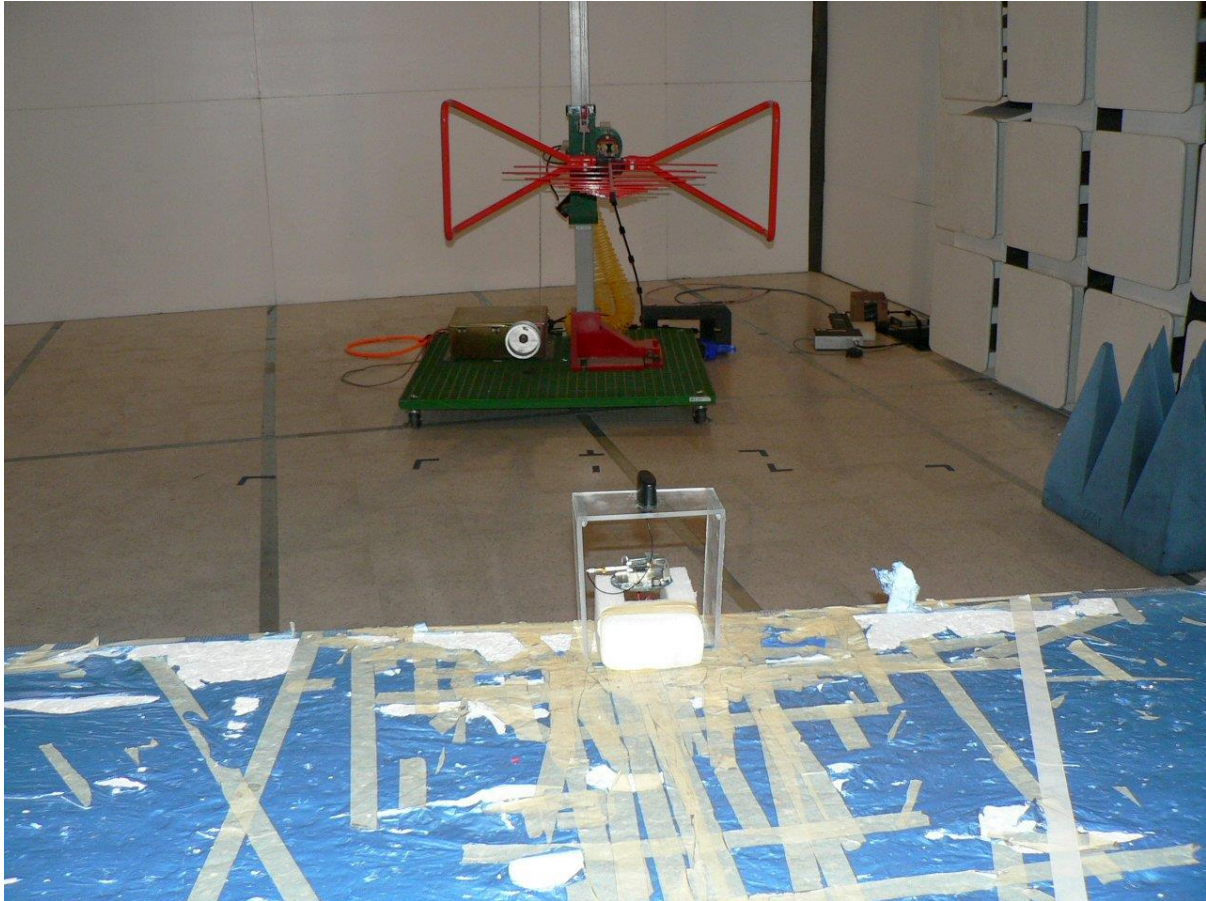



Title: Silver Spring Networks NIC 451
To: CISPR 22 / ICES-003 / FCC Part 15B Emissions
Serial #: SSNT92-U8 Rev A
Issue Date: 16th April 2015
Page: 30 of 31

7. TEST EQUIPMENT DETAILS

Asset #	Instrument	Manufacturer	Part #	Serial #	Calibration Due Date
158	Barometer/ Thermometer	Control Co.	4196	E2846	6 Dec 2015
190	LISN (two-line V-network)	Rhode & Schwarz	ESH3Z5	836679/006	12 Sep 2015
193	Receiver 20 Hz to 7 GHz	Rhode & Schwarz	ESI 7	838496/007	14 Jan 2016
287	EMI Receiver	Rhode & Schwarz	ESIB40	100201	31 Jul 2015
307	BNC Cable	Megaphase	1689 1GVT4	15F50B002	N/A
310	SMA Cable	Micro-Coax	UFA210A-0-0787-3G03G0	209089-001	N/A
312	SMA Cable	Micro-Coax	UFA210A-1-1181-3G0300	209092-001	N/A
338	30 - 3000 MHz Antenna	Sunol	JB3	A052907	14 Aug 2015
393	Low Pass Filter 1050MHz	Minicircuits	WLFX-1050		N/A
396	Notch Filter 2.4G	Microtronics	BRM50701		N/A
397	Preamp 10-2500 MHz	MiCOM Labs		0397	23 Oct 2015
399	Horn Antenna 1-18G	ETS	3117	00154575	10 Oct 2015
406	Preamp 1-18 GHz	MiCOM Labs		0406	30 May 2015
411	Mast/Turntable Control	Sunol Sciences	SC98V	060199-1D	N/A
413	Mast Controller	Sunol Sciences	TWR95-4	030801-3	N/A
415	Turntable Controller	Sunol Sciences		0415	N/A
416	Gigabit Ethernet Filter	ETS	260366	0416	N/A
0502	EMC Test Software	EMISoft	Vasona	5.0051	N/A

This test report may be reproduced in full only. The document may only be updated by MiCOM Labs personnel and any changes noted in the Document History section of the report.



575 Boulder Court
Pleasanton, California 94566, USA
Tel: 1.925.462.0304
Fax: 1.925.462.0306
www.micomlabs.com