

EMISSIONS TEST REPORT FOR A LOW POWER TRANSMITTER

I. GENERAL INFORMATION

Requirement: FCC
Test Requirements: FCC Part 15

Applicant: Silver Spring Networks
575 Broadway Street
Redwood City, CA 94063

FCC ID: OWS-NIC45
IC: 5975A-NIC45
Model No.: NIC45

II. DESCRIPTION OF EQUIPMENT UNDER TEST (EUT)

The Silver Spring Networks (SSN) model NIC45 is an access point for electric power meter communications use. The radio incorporates a dual band 900 MHz/ 2.4 GHz frequency hopping mesh network radio. Test data for 900 MHz FHSS operation are provided in a separate report.

III. TEST DATES AND TEST LOCATION

Testing was performed on various dates between 17 January and 4 April 2013.

Radiated emissions and antenna port conducted emissions:

BACL Laboratories
1274 Anvilwood Ave.
Sunnyvale, CA 94089

Antenna port conducted emissions tests were performed at Silver Spring Networks.



T.N. Cokenias
EMC Consultant/Agent for Silver Spring Networks

7 April 2013

15.203 Antenna connector requirement

Antenna description	Mfr.	Model No.	Gain
External monopole antenna (omni)	WP Wireless	WP ANT30017-CA	2.5 dBi at 915 MHz 3.5 dBi at 2.4 GHz

TEST PROCEDURES

All tests were performed in accordance with the applicable procedures called out in the following documents, unless otherwise noted:

FCC 47CFR15

DA 00-705: Filing and Measurement Guidelines for Frequency Hopping Spread Spectrum Systems

RSS-Gen Issue 3: General Requirements and Information for the Certification of Radio Apparatus

RSS-210 Issue 8: Low power license exempt radio frequency devices (December 2010)

RSS-212: Test Facilities and Test Methods for Radio Equipment

ANSI C63.4 – 2003, American National Standard for Methods of Measurement of Radio-Noise Emissions from Low-Voltage Electrical and Electronic Equipment in the Range of 9 kHz to 40 GHz.

Laboratory Accreditation Information

BACL

2.948 FCC Registration Number: 90464

Industry Canada Test Site Registration Number: 3062A

Accrediting Body:: A2LA

Test Equipment

Silver Spring Networks:

Equipment	Mfr	Model	Serial No.	Cal Due
Spectrum analyzer	Agilent	E4405B	MY45113391	01/23/13
Spectrum analyzer	Agilent	N9030A	MY48030147	01/23/13

BACL

Manufacturer	Description	Model No.	Serial No.	Calibration Due
Rohde & Schwarz	EMI Test Receiver	ESCI 1166.5950K03	100337	2013-03-22
Agilent	Spectrum Analyzer	E4440A	MY44303352	2013-05-10
Sunol Science Corp	System Controller	SC99V	122303-1	N/R
Sunol Science Corp	Combination Antenna	JB3	A0020106-3	2013-06-29
EMCO	Horn antenna	3115	9511-4627	2013-10-03
Hewlett Packard	Pre amplifier	8447D	2944A06639	2013-06-09
Mini-Circuits	Pre Amplifier	ZVA-183-S	570400946	2013-05-09

Test Set-up Diagram

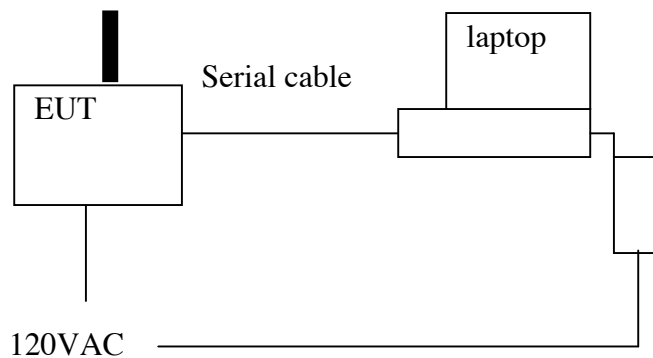

Support Equipment

Equipment	Mfr	Model	Asset No.
Laptop PC	Dell	PP01L	TW-0791UH1280-OC9-6558
AC/DC adapter	CUI Inc.	DSA-60W-20	2607HB

2.4 GHZ FREQUENCY HOPPING SPREAD SPECTRUM RADIO EMISSIONS

The 2.4 GHz FHSS will employ the following modulations:

<u>Data Rate</u>	<u>Modulation</u>
250 kbps	GFSK
500 kbps	GFSK

Output power is the same at both modulations.

TEST RESULTS

Radiated Test Set-up, 30 MHz-24.835 GHz

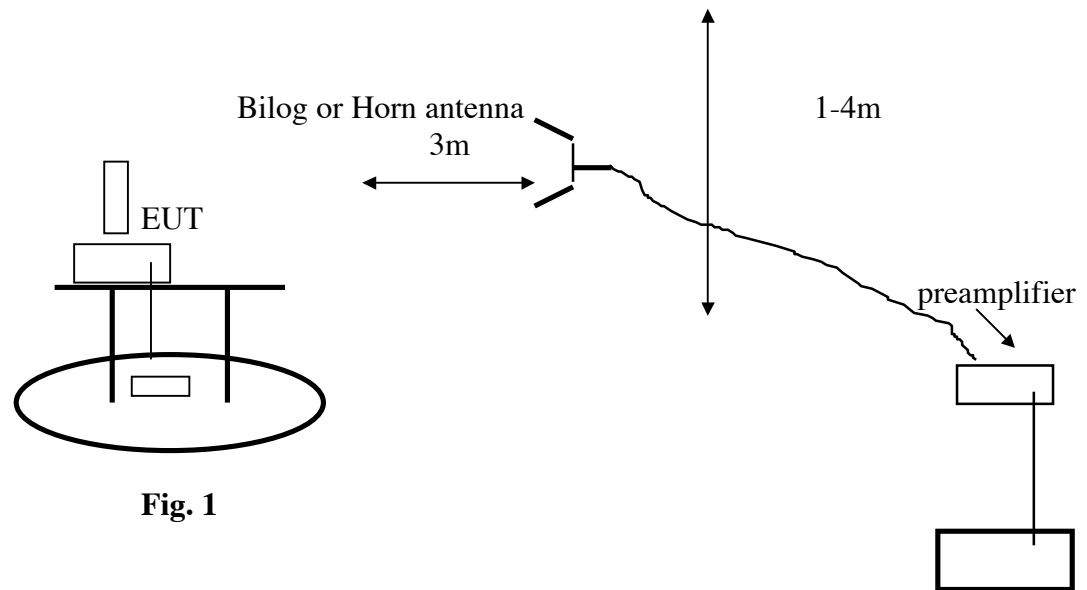

Fig. 1

Test Procedures

Radiated emissions generated by the transmitter portion of the EUT were measured.

1. The EUT was placed on a wooden table resting on a turntable on the test site. The search antenna was placed 3m from the EUT. The EUT antenna was mounted in the with the EUT TX antenna pointed directly to the search antenna.
2. The turntable was slowly rotated to locate the direction of maximum emission at each emission falling in the restricted bands of 15.205.
3. Emissions were investigated to the 10th harmonic of the fundamental.
4. Once maximum direction was determined, the search antenna was raised and lowered in both vertical and horizontal polarizations. The maximum readings so obtained are recorded in the data listed below.

Test Results: Worst-case results are presented. Refer to data sheets below. Restricted band emissions meet 54 dBuV/m. Other undesired emissions from the transmitter meet the -20 dBc requirement in 15.247(d).

15.205 Restricted Frequency Bands

MHz	MHz	MHz	GHz
0.090 - 0.110	16.42 - 16.423	399.9 - 410	4.5 - 5.15
0.495 - 0.505 (1)	16.69475 - 16.69525	608 - 614	5.35 - 5.46
2.1735 - 2.1905	16.80425 - 16.80475	960 - 1240	7.25 - 7.75
4.125 - 4.128	25.5 - 25.67	1300 - 1427	8.025 - 8.5
4.17725 - 4.17775	37.5 - 38.25	1435 - 1626.5	9.0 - 9.2
4.20725 - 4.20775	73 - 74.6	1645.5 - 1646.5	9.3 - 9.5
6.215 - 6.218	74.8 - 75.2	1660 - 1710	10.6 - 12.7
6.26775 - 6.26825	108 - 121.94	1718.8 - 1722.2	13.25 - 13.4
6.31175 - 6.31225	123 - 138	2200 - 2300	14.47 - 14.5
8.291 - 8.294	149.9 - 150.05	2310 - 2390	15.35 - 16.2
8.362 - 8.366	156.52475 -	2483.5 - 2500	17.7 - 21.4
8.37625 - 8.38675	156.52525	2655 - 2900	22.01 - 23.12
8.41425 - 8.41475	156.7 - 156.9	3260 - 3267	23.6 - 24.0
12.29 - 12.293	162.0125 - 167.17	3332 - 3339	31.2 - 31.8
12.51975 - 12.52025	167.72 - 173.2	3345.8 - 3358	36.43 - 36.5
12.57675 - 12.57725	240 - 285	3600 - 4400	
13.36 - 13.41	322 - 335.4		

15.209 General Field Strength Limits

Frequency (MHz)	Field Strength (microvolts/meter)	Measurement Distance (meters)
0.009 - 0.490	2400/F (kHz)	300
0.490 - 1.705	24000/F (kHz)	30
1.705 - 30.0	30	30
30 - 88	100 **	3
88 - 216	150 **	3
216 - 960	200 **	3
Above 960	500	3

Radiated emissions above 1 GHz, LOW channel



Company Name: Silver Spring Networks
 Product Type: Board
 Project Number:T1301171
 Tester: Wei Sun
 Date: 2013-01-17
 FCC 15 C in 5 M Chamber 2 at 3 meters distance
 Notes: 170-0227-01 RFMD MAC:200232 GFSK modulation

Frequency (MHz)	S.A. Reading (dBµV)	Azimuth (degrees)	Test Antenna			Cable Loss (dB)	Pre-Amp. (dB)	Cord. Reading (dBµV/m)	FCC 15.247		Comments	Power setti
			Height (cm)	Polarity (H/V)	Factor (dB/m)				Limit (dBµV/m)	Margin (dB)		
Low channel 2400.8 MHz measured at 3 meters 100kbps												
4801.6	39.22	318	100	V	32.71	4.56	27.78	48.71	74	-25.29	Peak	112=13
4801.6	35.27	318	100	V	32.71	4.56	27.78	44.76	54	-9.24	Ave	112=13
4801.6	38.47	110	100	H	32.71	4.56	27.78	47.96	74	-26.04	Peak	112=13
4801.6	34.32	110	100	H	32.71	4.56	27.78	43.81	54	-10.19	Ave	112=13
7202.4	35.75	40	100	V	36.24	5.49	27.59	49.89	74	-24.11	Peak	112=13
7202.4	38.36	42	107	H	36.24	5.49	27.59	52.5	74	-21.5	Peak	112=13
9603.2	33.32	350	100	V	37.36	6.54	27.05	50.17	74	-23.83	Peak	112=13
9603.2	33.89	245	100	H	37.36	6.54	27.05	50.74	74	-23.26	Peak	112=13
12004	30	0	100	V	41.04	7.78	27.02	51.8	74	-22.2	Prak	112=13
12004	17	0	100	V	41.04	7.78	27.02	38.8	54	-15.2	Ave	112=13
12004	30	0	100	H	41.04	7.78	27.02	51.8	74	-22.2	Peak	112=13
12004	17	0	100	H	41.04	7.78	27.02	38.8	54	-15.2	Ave	112=13
4801.6	37.41	234	100	V	32.71	4.56	27.78	46.9	74	-27.1	Peak	112=13
4801.6	31.7	234	100	V	32.71	4.56	27.78	41.19	54	-12.81	Ave	112=15
4801.6	36.68	112	119	H	32.71	4.56	27.78	46.17	74	-27.83	Peak	112=15
4801.6	30.34	112	119	H	32.71	4.56	27.78	39.83	54	-14.17	Ave	112=15
12004	30	0	100	V	41.04	7.78	27.02	51.8	74	-22.2	Prak	112=15
12004	17	0	100	V	41.04	7.78	27.02	38.8	54	-15.2	Ave	112=15
12004	30	0	100	H	41.04	7.78	27.02	51.8	74	-22.2	Peak	112=15
12004	17	0	100	H	41.04	7.78	27.02	38.8	54	-15.2	Ave	112=15

Radiated emissions above 1 GHz, MID channel



Bay Area Compliance Lab Corp.

Bay Area Compliance Lab Corp.

Company Name: Silver Spring Networks

Product Type: Board

Project Number:T1301171

Tester: Wei Sun

Date: 2013-01-17

FCC 15 C in 5 M Chamber 2 at 3 meters distance

Notes: 170-0227-01 RFMD MAC:200232 GFSK modulation

Frequency (MHz)	S.A. Reading (dBµV)	Azimuth (degrees)	Test Antenna			Cable Loss (dB)	Pre-Amp. (dB)	Cord. Reading (dBµV/m)	FCC 15.247		Comments	Power setti	
			Height (cm)	Polarity (H/V)	Factor (dB/m)				Limit (dBµV/m)	Margin (dB)			
Middle channel 2440MHz measured at 3 meters 100kbps													
4880	37.3	312	100	V	32.86	4.54	27.67	47.03	74	-26.97	Peak	112=13	data rate:2f
4880	31.57	312	100	V	32.86	4.54	27.67	41.3	54	-12.7	Ave	112=13	data rate:2f
4880	37.12	61	100	H	32.86	4.54	27.67	46.85	74	-27.15	Peak	112=13	data rate:2f
4880	30.94	61	100	H	32.86	4.54	27.67	40.67	54	-13.33	Ave	112=13	data rate:2f
7320	36.22	140	100	V	36.52	5.57	27.51	50.8	74	-23.2	Peak	112=13	data rate:2f
7320	28.78	140	100	V	36.52	5.57	27.51	43.36	54	-10.64	Ave	112=13	data rate:2f
7320	37.71	108	100	H	36.52	5.57	27.51	52.29	74	-21.71	Peak	112=13	data rate:2f
7320	31.75	108	100	H	36.52	5.57	27.51	46.33	54	-7.67	Ave	112=13	data rate:2f
9760	31.91	127	100	V	37.38	6.58	26.98	48.89	74	-25.11	Peak	112=13	data rate:2f
9760	33.64	39	100	H	37.38	6.58	26.98	50.62	74	-23.38	Peak	112=13	data rate:2f
12200	30	0	100	V	40.59	7.89	26.99	51.49	74	-22.51	Peak	112=13	data rate:2f
12200	17	0	100	V	40.59	7.89	26.99	38.49	54	-15.51	Ave	112=13	data rate:2f
12200	30	0	100	H	40.59	7.89	26.99	51.49	74	-22.51	Peak	112=13	data rate:2f
12200	17	0	100	H	40.59	7.89	26.99	38.49	54	-15.51	Ave	112=13	data rate:2f
4880	37.5	234	100	V	32.86	4.54	27.67	47.23	74	-26.77	Peak	112=15	data rate: 5
4880	31.88	234	100	V	32.86	4.54	27.67	41.61	54	-12.39	Ave	112=15	data rate: 5
4880	36.71	128	100	H	32.86	4.54	27.67	46.44	74	-27.56	Peak	112=15	data rate: 5

Radiated emissions above 1 GHz, HIGH channel



Company Name: Silver Spring Networks
 Product Type: Board
 Project Number:T1301171
 Tester: Wei Sun
 Date: 2013-01-17
 FCC 15 C in 5 M Chamber 2 at 3 meters distance
 Notes: 170-0227-01 RFMD MAC: GFSK modulation

Frequency (MHz)	S.A. Reading (dBµV)	Azimuth (degrees)	Test Antenna			Cable Loss (dB)	Pre-Amp. (dB)	Cord. Reading (dBµV/m)	FCC 15.247		Comments	Power setting
			Height (cm)	Polarity (H/V)	Factor (dB/m)				Limit (dBµV/m)	Margin (dB)		
high channel 2472.8 MHz measured at 3 meters 100kbps												
4945.6	34.84	24	100	V	32.86	4.52	27.7	44.52	74	-29.48	Peak	112=15
4945.6	24.54	24	100	V	32.86	4.52	27.7	34.22	54	-19.78	Ave	112=15
4945.6	34.01	260	100	H	32.86	4.52	27.7	43.69	74	-30.31	Peak	112=15
4945.6	22.97	260	100	H	32.86	4.52	27.7	32.65	54	-21.35	Ave	112=15
7418.4	36.09	301	100	V	36.43	5.6	27.57	50.55	74	-23.45	Peak	112=15
7418.4	29.86	301	100	V	36.43	5.6	27.57	44.32	54	-9.68	Ave	112=15
7418.4	38.2	131	100	H	36.43	5.6	27.57	52.66	74	-21.34	Peak	112=15
7418.4	33.07	131	100	H	36.43	5.6	27.57	47.53	54	-6.47	Ave	112=15
9891.2	32.93	173	147	V	37.53	6.55	26.95	50.06		50.06	Peak	112=15
9891.2	32.14	15	100	H	37.53	6.55	26.95	49.27		49.27	Peak	112=15
4945.6	34.3	52	100	V	32.86	4.52	27.7	43.98	74	-30.02	Peak	112=15
4945.6	24.95	52	100	V	32.86	4.52	27.7	34.63	54	-19.37	Ave	112=15
4945.6	34.2	294	100	H	32.86	4.52	27.7	43.88	74	-30.12	Peak	112=15
4945.6	23.54	294	100	H	32.86	4.52	27.7	33.22	54	-20.78	Ave	112=15
7418.4	36.74	34	100	V	36.43	5.6	27.57	51.2	74	-22.8	Peak	112=15
7418.4	30.09	34	100	V	36.43	5.6	27.57	44.55	54	-9.45	Ave	112=15
7418.4	36.99	239	100	H	36.43	5.6	27.57	51.45	74	-22.55	Peak	112=15
7418.4	30.03	239	100	H	36.43	5.6	27.57	44.49	54	-9.51	Ave	112=15
9891.2	34.94	342	146	V	37.53	6.55	26.95	52.07		52.07	Peak	112=15
9891.2	34.92	7	149	H	37.53	6.55	26.95	52.05		52.05	Peak	112=15
12364	35.3	23	140	V	40.02	7.88	26.97	56.23	74	-17.77	Peak	112=15
12364	27.45	23	140	V	40.02	7.88	26.97	48.38	54	-5.62	Ave	112=15
12364	33.5	309	100	H	40.02	7.88	26.97	54.43	74	-19.57	Peak	112=15
12364	23.67	309	100	H	40.02	7.88	26.97	44.6	54	-9.4	Ave	112=15

Radiated Emissions, Bandedge



Company Name: Silver Spring Networks

Product Type: Board

Project Number:T1301171

Tester: Wei Sun

Date: 2013-01-17

FCC 15 C in 5 M Chamber 2 at 3 meters distance

Notes: 170-0227-01 RFMD MAC:200232 GFSK modulation

BAND EDGE EMISSIONS

Worst case data rate: 500 kbps

Frequency (MHz)	S.A. Reading (dBuV)	Azimuth (degrees)	Test Antenna			Cable Loss (dB)	Pre-Amp. (dB)	Cord. Reading (dBuV/m)	FCC 15.247		Comments	Power setti
			Height (cm)	Polarity (H/V)	Factor (dB/m)				Limit (dBuV/m)	Margin (dB)		
Low channel 2400.8 MHz measured at 3 meters 100kbps												
2374	33.38	41	100	V	28.98	3.12	0	65.48	74	-8.52	Prak	112=15
2374	21.63	41	100	V	28.98	3.12	0	53.73	54	-0.27	Ave	112=15
2390	27	0	100	H	28.98	3.12	0	59.1	74	-14.9	Peak	112=15
2390	12	0	100	H	28.98	3.12	0	44.1	54	-9.9	Ave	112=15

Frequency (MHz)	S.A. Reading (dBuV)	Azimuth (degrees)	Test Antenna			Cable Loss (dB)	Pre-Amp. (dB)	Cord. Reading (dBuV/m)	FCC 15.247		Comments	Power setti
			Height (cm)	Polarity (H/V)	Factor (dB/m)				Limit (dBuV/m)	Margin (dB)		
high channel 2472.8 MHz measured at 3 meters 100kbps												
2483.5	32.14	120	100	V	29.12	3.25	0	64.51	74	-9.49	Peak	112=15
2483.5	18.1	120	100	V	29.12	3.25	0	50.47	54	-3.53	Ave	112=15
2483.5	34	0	100	H	29.12	3.25	0	66.37	74	-7.63	Peak	112=15
2483.5	12	0	100	H	29.12	3.25	0	44.37	54	-9.63	Ave	112=15

Radiated Emissions Below 1 GHZ

All emissions from transmitter were below 15.205 and 15.247 limits as applicable.

Worst-case emissions (HIGH channel)

F, MHz	Raw dBuV	Cable Loss	AF dB	Level dBuV/m	Meas.	Pol	Hgt cm	Azt Deg	Limit dBuV/m	Margin dB	Pass /Fail	Comments
286.81375	16.81	10.93	-7.64	20.09	Quasi Max	H	111	219	46	-25.91	Pass	
321.74825	26.52	11	-6.93	30.59	Quasi Max	H	291	129	46	-15.41	Pass	
331.51675	26.14	11.02	-6.82	30.34	Quasi Max	H	100	220	46	-15.66	Pass	

20 dBc Bandwidth

LIMIT

15.247(a) i: 500 kHz maximum bandwidth allowed.

TEST PROCEDURE

The TX output is connected to a spectrum analyzer. The OCC BW function is activated.

RBW > 1% of 20 dB BW

VBW > RBW

Detector: PEAK

RESULTS

No non-compliance noted:

CHANNEL	FREQUENCY (MHZ)	-20dBc BW 250 kbps (kHz)	-20dBc BW 500 kbps (kHz)
0: LOW	2401	266.9	520.7
49: MID	2440	267	520.7
90: HIGH	2473	267	521.1

20 dB BANDWIDTH Ch. 0 LOW CHANNEL – 250 kbps

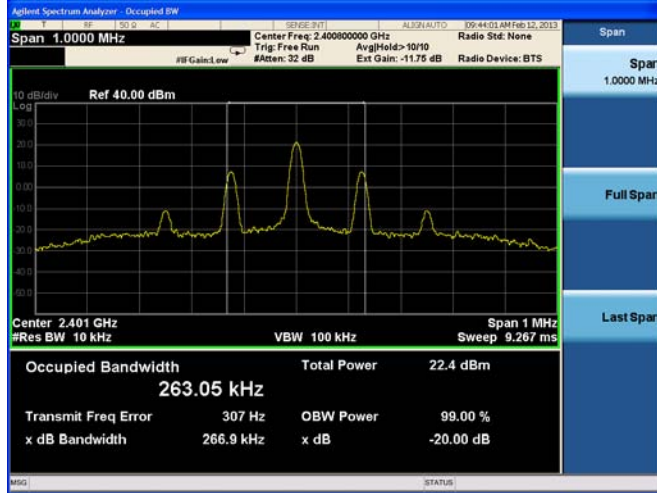

20 dB BANDWIDTH Ch. 49 MID CHANNEL – 250 kbps

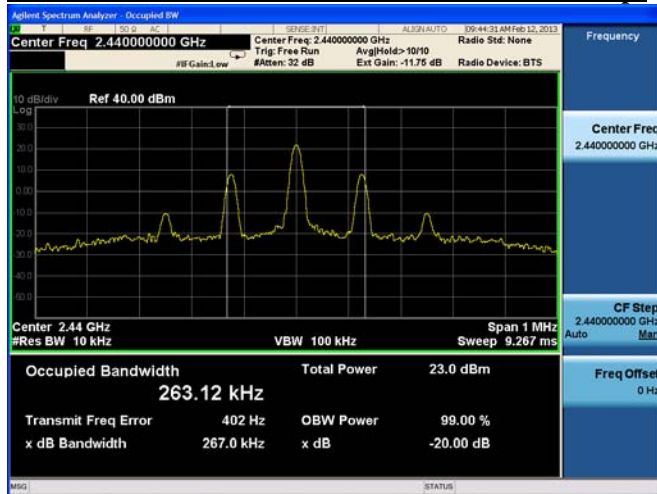

20 dB BANDWIDTH Ch. 90 HIGH CHANNEL – 250 kbps

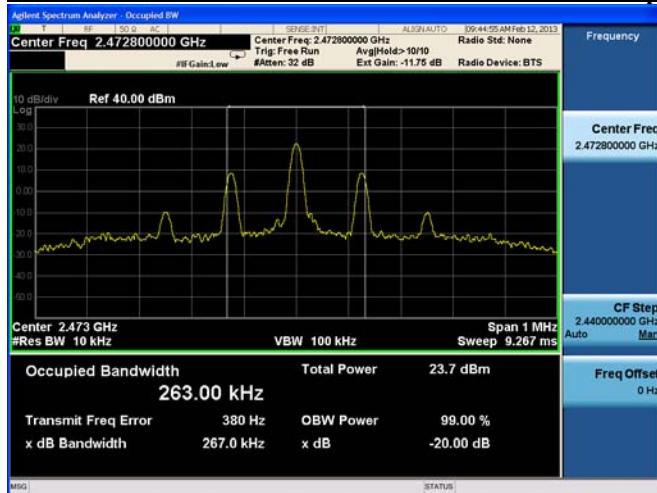

20 dB BANDWIDTH Ch. 0 LOW CHANNEL – 500 kbps

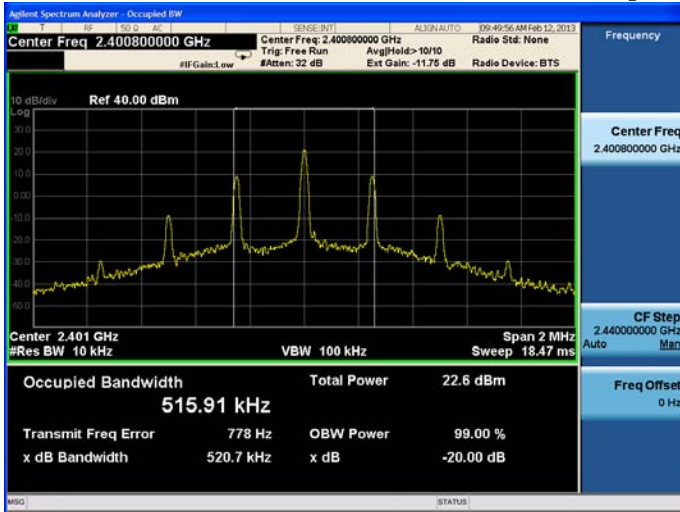

20 dB BANDWIDTH Ch. 49 MID CHANNEL – 500 kbps

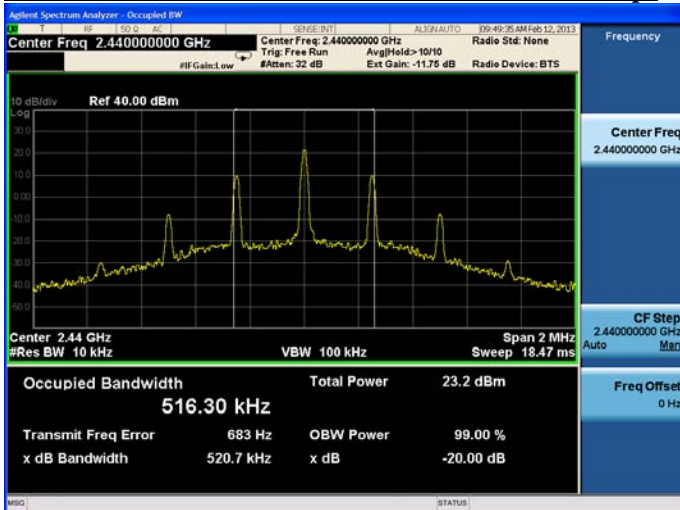

20 dB BANDWIDTH Ch. 90 HIGH CHANNEL – 500 kbps

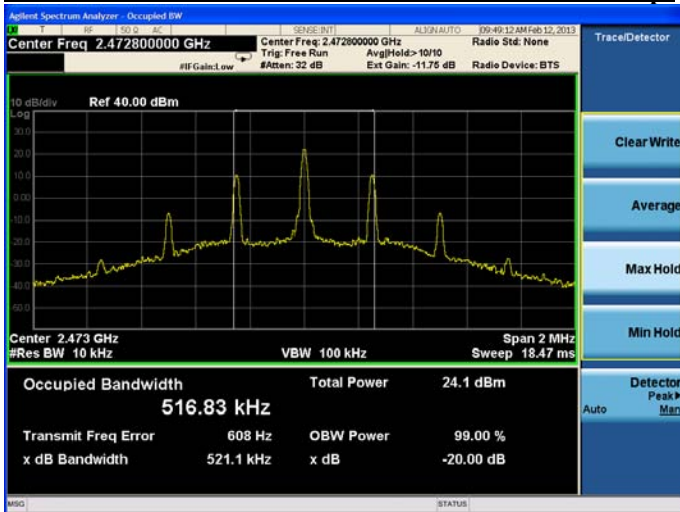

99% Occupied Bandwidth

LIMIT

None, for information purposes only.

The TX output is connected to a spectrum analyzer. The OCC BW function is activated.

RBW > 1% of SPAN

VBW > 3xRBW

Detector: SAMPLE

RESULTS

No non-compliance noted.

CHANNEL	FREQUENCY (MHZ)	99% Occ BW 250 kbps (kHz)	99% Occ BW 500 kbps (kHz)
0: LOW	2401	261.07	513.42
49: MID	2440	261.36	513.35
90: HIGH	2473	261.3	513.71

99% BW, Ch. 0 Low Channel – 250 kbps

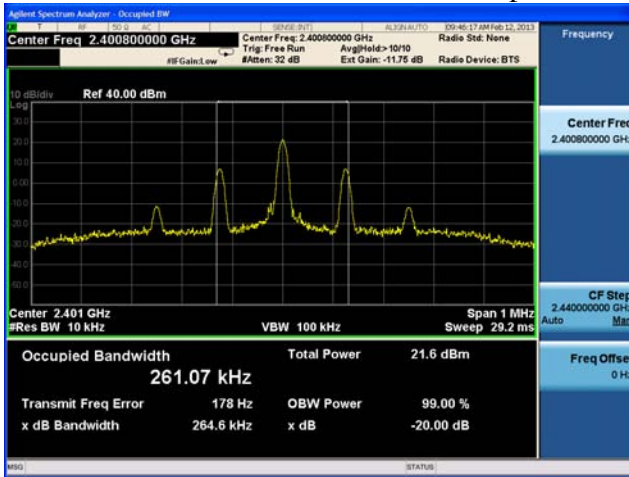

99% BW, Ch. 49 Mid Channel – 250 kbps

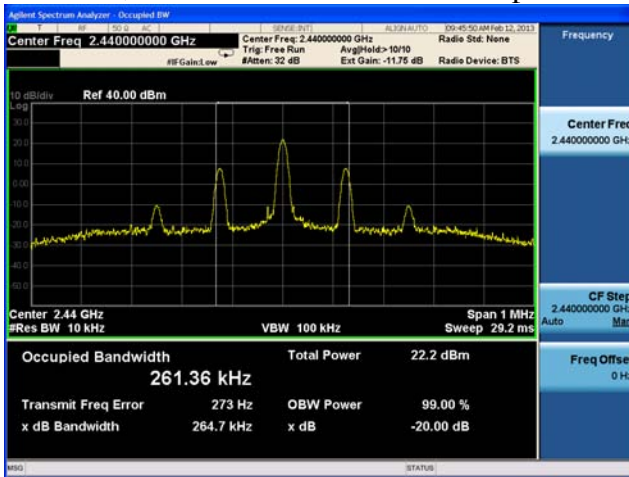

99% BW, Ch. 90 High Channel – 250 kbps

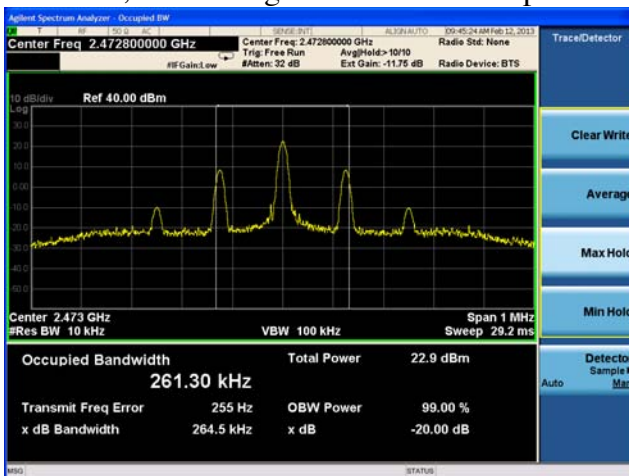

99% BW, Ch. 0 Low Channel– 500 kbps

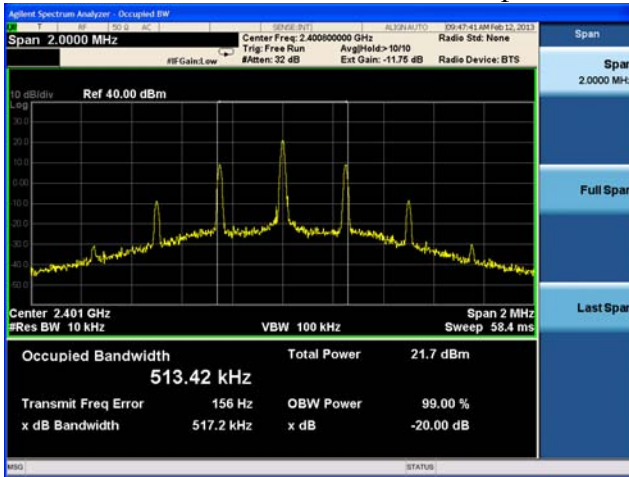

99% BW, Ch. 49 Mid Channel– 500 kbps

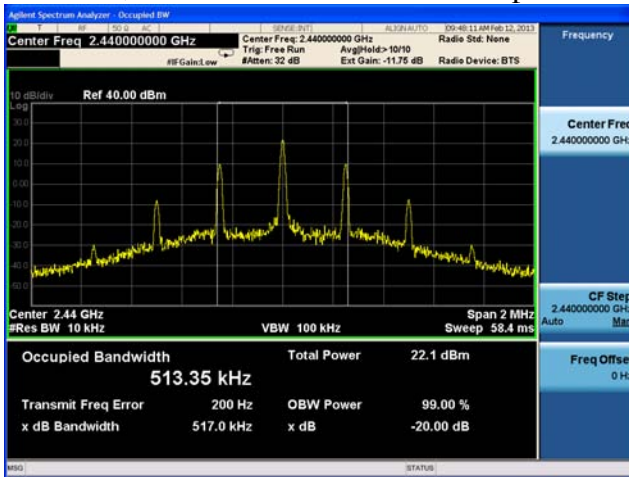

99% BW, Ch. 90 High Channel– 500 kbps

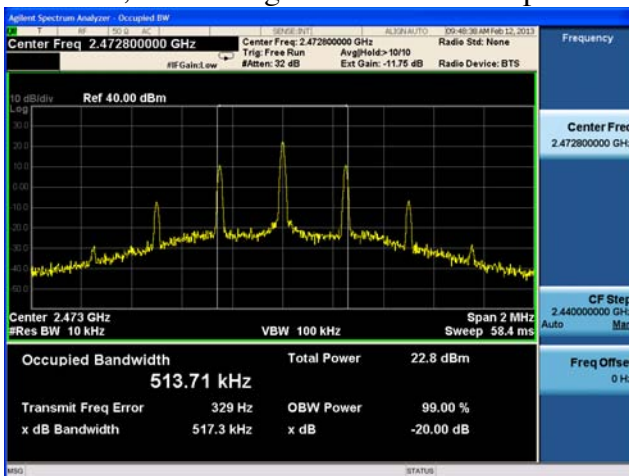

HOPPING FREQUENCY SEPARATION

LIMIT

§15.247 (a) (1) Frequency hopping systems shall have hopping channel carrier frequencies separated by a minimum of 25 kHz or the 20 dB bandwidth of the hopping channel, whichever is greater.

TEST PROCEDURE

The transmitter output is connected to a spectrum analyzer. The RBW is set to 100 kHz and the VBW is set to $>3 \times \text{RBW}$ (1MHz). The sweep time is coupled.

RESULTS

No non-compliance noted:

HOPPING FREQUENCY SEPARATION

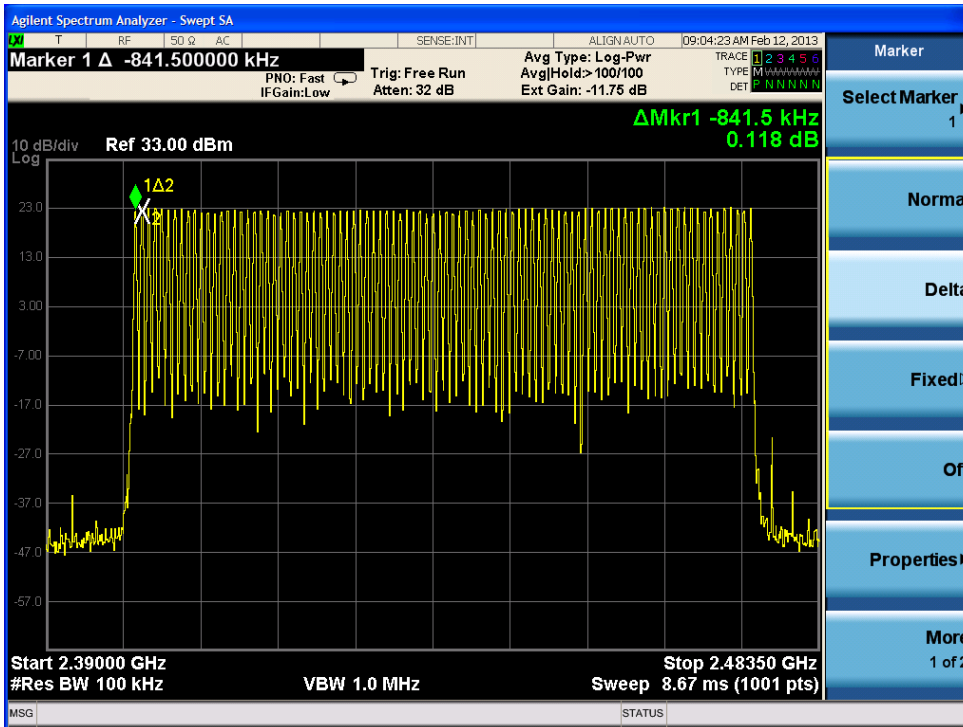

NUMBER OF HOPPING CHANNELS

LIMIT

§15.247 (a) (1)(iii) Frequency hopping systems in the 2400-2483.5 MHz band shall use at least 15 channels.

TEST PROCEDURE

The transmitter output is connected to a spectrum analyzer. The span is set to cover the entire authorized band, in either a single sweep or in multiple contiguous sweeps. The RBW is set to 100kHz so that individual channels could be resolved all on one screen. The analyzer is set to Max Hold.

RESULTS

No non-compliance noted.

90 hopping channels used.

Note: The total number of channels possible from the radio is 99 channels, but only 90 channels are used due to band edge emissions considerations. The test software however displays all available channels, so there are more channels shown in the spectrum analyzer display than will actually be used.

NUMBER OF HOPPING CHANNELS

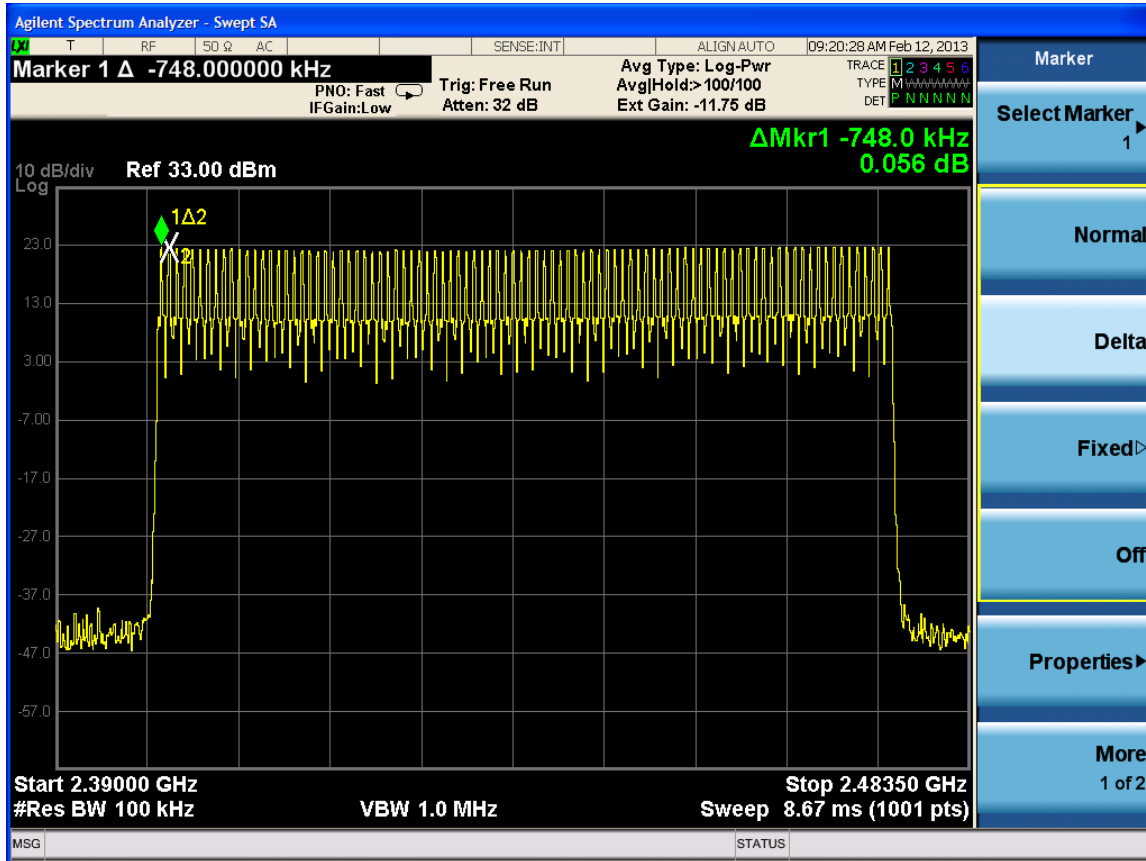

AVERAGE TIME OF OCCUPANCY

LIMIT

§15.247 (a) (1) (iii) Frequency hopping systems in the 2400-2483.5 MHz band shall use at least 15 channels. The average time of occupancy on any channel shall not be greater than 0.4 seconds within a period of 0.4 seconds multiplied by the number of hopping channels employed. Frequency hopping systems may avoid or suppress transmissions on a particular hopping frequency provided that a minimum of 15 channels are used.

TEST PROCEDURE

The transmitter output is connected to a spectrum analyzer. The span is set to 0 Hz, centered on a single, selected hopping channel. The width of a single pulse is measured in a fast scan. The number of pulses is measured in a 20 second scan, to enable resolution of each occurrence.

RESULTS

No non-compliance noted.

90 channels x 0.4 sec = 36 sec

Maximum occupancy allowed: 0.4 sec in 40 sec = 0.2 sec in 20 sec.

Hop duration msec	Total hops/20 sec	Average time of occupancy msec 36 sec	Limit in 36 sec msec
18.2	19	345.8	400

Hop duration

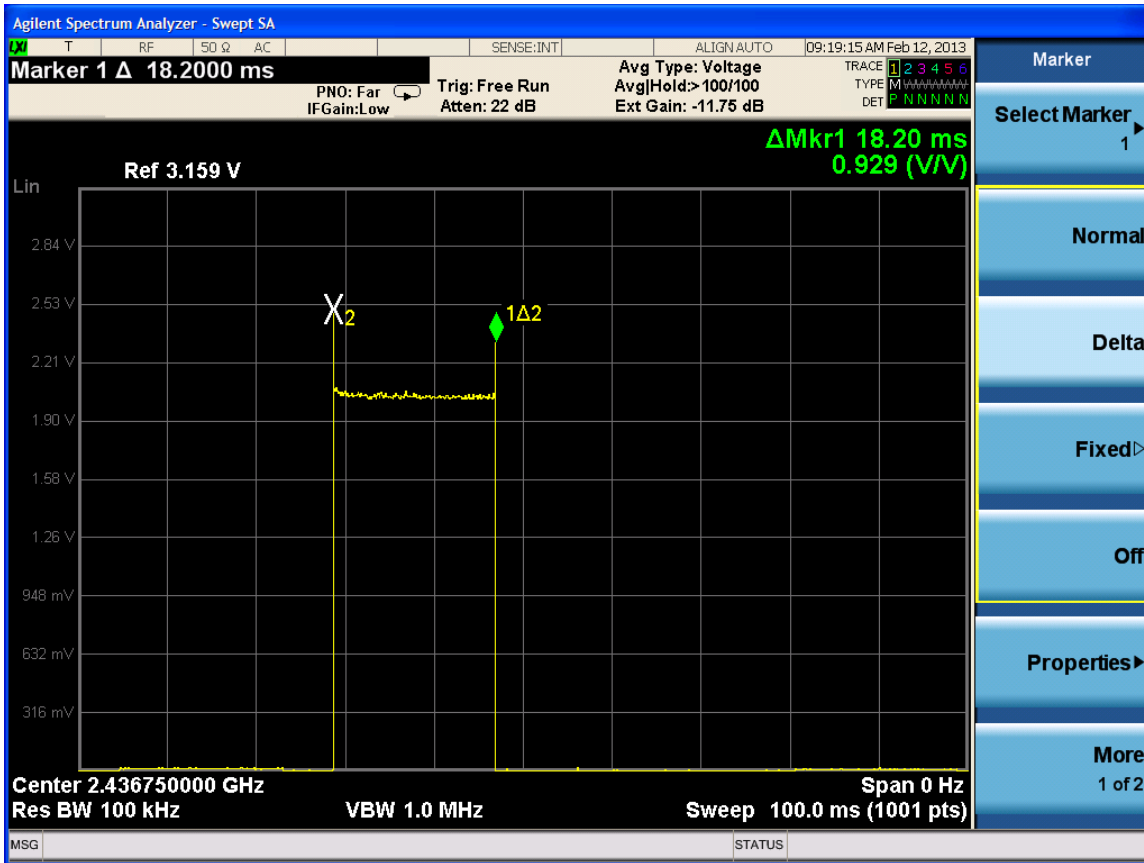

NUMBER OF PULSES IN 36 SECOND OBSERVATION PERIOD

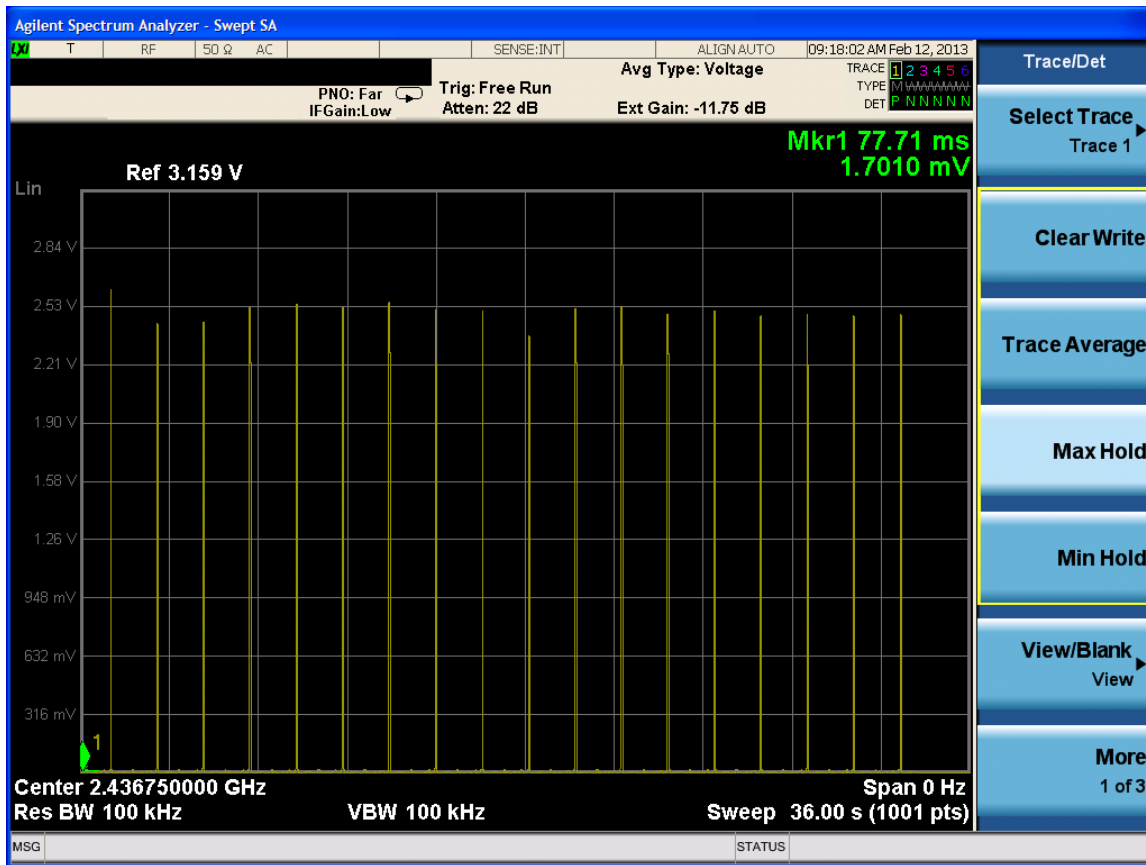

PEAK OUTPUT POWER

PEAK POWER LIMIT

§15.247 (b) The maximum peak conducted output power of the intentional radiator shall not exceed the following: (1) For frequency hopping systems operating in the 2400-2483.5 MHz band employing at least 75 non-overlapping hopping channels, and all frequency hopping systems in the 5725-5850 MHz band: 1 watt.

§15.247 (b) (4) Except as shown in paragraphs (b)(3) (i), (ii) and (iii) of this section, if transmitting antennas of directional gain greater than 6 dBi are used the peak output power from the intentional radiator shall be reduced below the stated values in paragraphs (b)(1) or (b)(2) of this section, as appropriate, by the amount in dB that the directional gain of the antenna exceeds 6 dBi.

The maximum antenna gain is 3.6 dBi, therefore the power limit is 30 dBm.

TEST PROCEDURE

The transmitter output is connected to a spectrum analyzer and the analyzer bandwidth is set to a value greater than the emissions bandwidth of the EUT.

RESULTS

No non-compliance noted:

Channel	Frequency	P out
0: Low	2401	21.556
49: Mid	2440	22.101
90: High	2472.8	22.734

OUTPUT POWER LOW CHANNEL

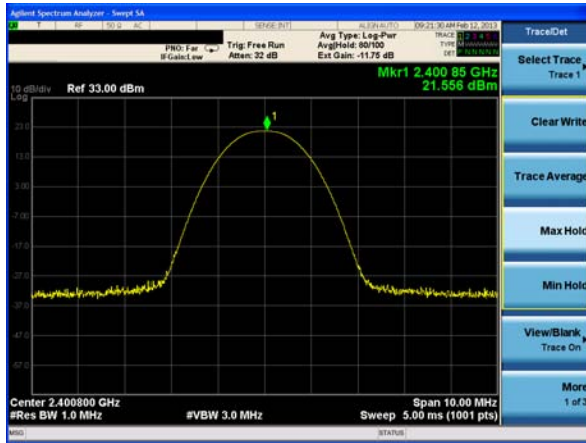

OUTPUT POWER MID CHANNEL

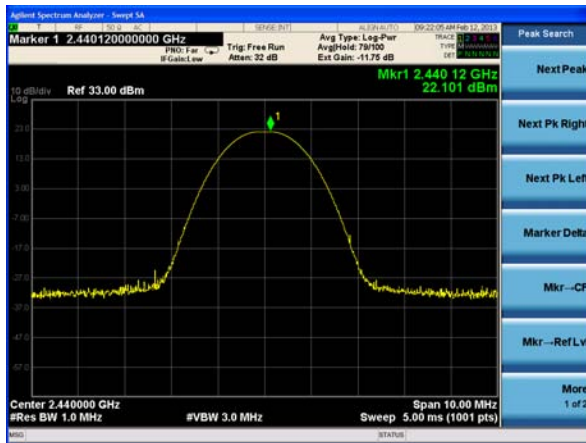

OUTPUT POWER HIGH CHANNEL

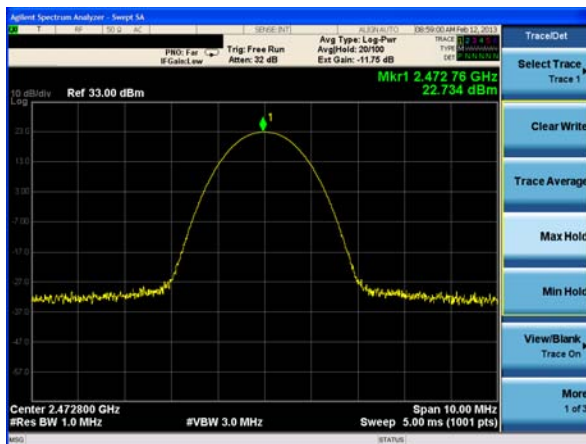

MAXIMUM PERMISSIBLE EXPOSURE

LIMITS

§1.1310 The criteria listed in Table 1 shall be used to evaluate the environmental impact of human exposure to radio-frequency (RF) radiation as specified in §1.1307(b), except in the case of portable devices which shall be evaluated according to the provisions of §2.1093 of this chapter.

TABLE 1—LIMITS FOR MAXIMUM PERMISSIBLE EXPOSURE (MPE)

Frequency range (MHz)	Electric field strength (V/m)	Magnetic field strength (A/m)	Power density (mW/cm ²)	Averaging time (minutes)
(A) Limits for Occupational/Controlled Exposures				
0.3–3.0	614	1.63	*(100)	6
3.0–30	1842/f	4.89/f	*(900/f ²)	6
30–300	61.4	0.163	1.0	6
300–1500			f/300	6
1500–100,000			5	6
(B) Limits for General Population/Uncontrolled Exposure				
0.3–1.34	614	1.63	*(100)	30
1.34–30	824/f	2.19/f	*(180/f ²)	30

TABLE 1—LIMITS FOR MAXIMUM PERMISSIBLE EXPOSURE (MPE)—Continued

Frequency range (MHz)	Electric field strength (V/m)	Magnetic field strength (A/m)	Power density (mW/cm ²)	Averaging time (minutes)
30–300	27.5	0.073	0.2	30
300–1500			f/1500	30
1500–100,000			1.0	30

f = frequency in MHz

* = Plane-wave equivalent power density

NOTE 1 TO TABLE 1: Occupational/controlled limits apply in situations in which persons are exposed as a consequence of their employment provided those persons are fully aware of the potential for exposure and can exercise control over their exposure. Limits for occupational/controlled exposure also apply in situations when an individual is transient through a location where occupational/controlled limits apply provided he or she is made aware of the potential for exposure.

NOTE 2 TO TABLE 1: General population/uncontrolled exposures apply in situations in which the general public may be exposed, or in which persons that are exposed as a consequence of their employment may not be fully aware of the potential for exposure or can not exercise control over their exposure.

CALCULATIONS

Given

$$E = \sqrt{(30 * P * G) / d}$$

and

$$S = E^2 / 3770$$

where

E = Field Strength in Volts/meter

P = Power in Watts

G = Numeric antenna gain

d = Distance in meters

S = Power Density in milliwatts/square centimeter

Combining equations and rearranging the terms to express the distance as a function of the remaining variables yields:

$$d = \sqrt{((30 * P * G) / (3770 * S))}$$

Changing to units of Power to mW and Distance to cm, using:

$$P \text{ (mW)} = P \text{ (W)} / 1000 \text{ and}$$

$$d \text{ (cm)} = 100 * d \text{ (m)}$$

yields

$$d = 100 * \sqrt{((30 * (P / 1000) * G) / (3770 * S))}$$

$$d = 0.282 * \sqrt{(P * G / S)}$$

where

d = distance in cm

P = Power in mW

G = Numeric antenna gain

S = Power Density in mW/cm²

Substituting the logarithmic form of power and gain using:

$$P \text{ (mW)} = 10^{(P \text{ (dBm)} / 10)} \text{ and}$$

$$G \text{ (numeric)} = 10^{(G \text{ (dBi)} / 10)}$$

yields

$$d = 0.282 * 10^{((P + G) / 20)} / \sqrt{S} \quad \text{Equation (1)}$$

where

d = MPE distance in cm

P = Power in dBm

G = Antenna Gain in dBi

S = Power Density Limit in mW/cm²

Equation (1) and the measured peak power is used to calculate the MPE distance.

LIMITS

From §1.1310 Table 1 (B), $S = 1.0 \text{ mW/cm}^2$

RESULTS

No non-compliance noted:

Worst-case RF exposure condition is for internal antenna operation as the gain is higher

Power Density Limit (mW/cm²)	Output Power (dBm)	Antenna Gain (dBi)	S, mW/cm² at 20cm
1.0	22.73	3.50	0.08

MPE Distance: 5.8 cm (for 2400 MHz operation alone).

NOTE1: This radio is a dual 900/2400 MHz FHSS module and both transmitters can be active at the same time. When both transmitters are operating:

MPE Distance, cm = 16.5cm.

This distance is derived in a separate attachment.

NOTE2: For mobile or fixed location transmitters, minimum separation distance is for FCC compliance is 20 cm, even if calculations indicate MPE distance is less.

CONDUCTED SPURIOUS EMISSIONS

LIMITS

§15.247 (c) In any 100 kHz bandwidth outside the frequency band in which the spread spectrum intentional radiator is operating, the radio frequency power that is produced by the intentional radiator shall be at least 20 dB below that in the 100 kHz bandwidth within the band that contains the highest level of the desired power, based on either an RF conducted or a radiated measurement. Attenuation below the general limits specified in §15.209(a) is not required. In addition, radiated emissions which fall in the restricted bands, as defined in §15.205(a), must also comply with the radiated emission limits specified in §15.209(a) (see §15.205(c)).

TEST PROCEDURE

The transmitter output is connected to a spectrum analyzer. The resolution bandwidth is set to 100 kHz. The video bandwidth is set to 100 kHz.

The spectrum from 30 MHz to 10 GHz is investigated with the transmitter set to the lowest, middle, and highest channels.

RESULTS

No non-compliance noted:

SPURIOUS EMISSIONS, LOW CHANNEL

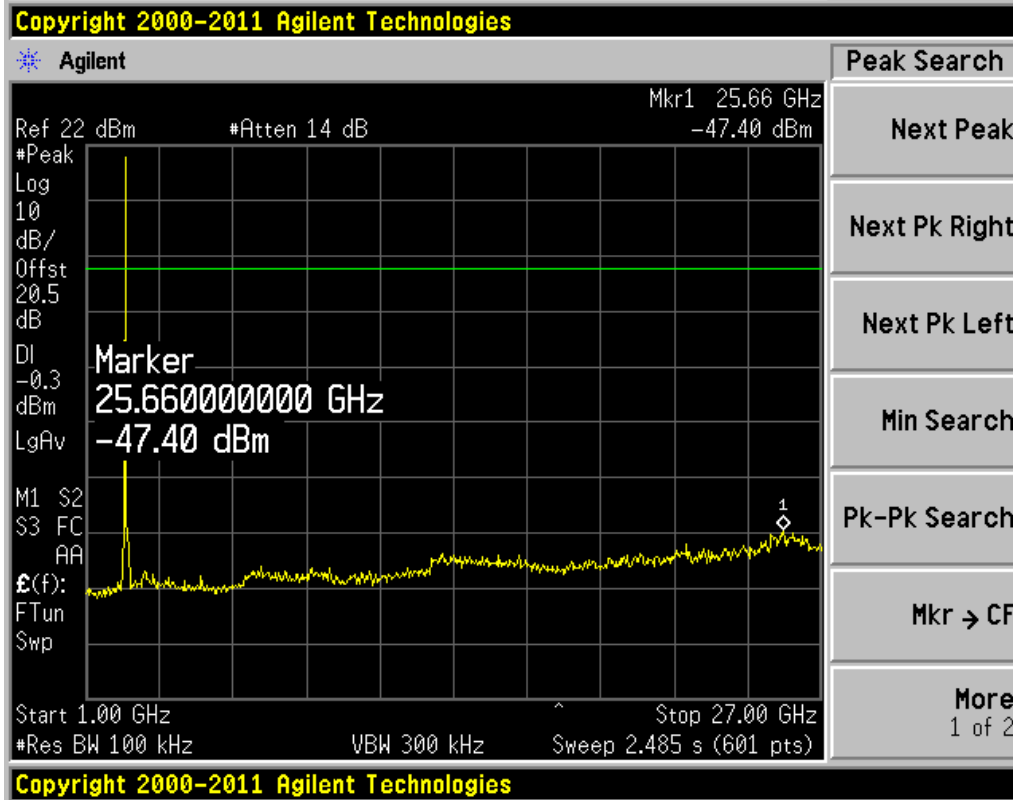
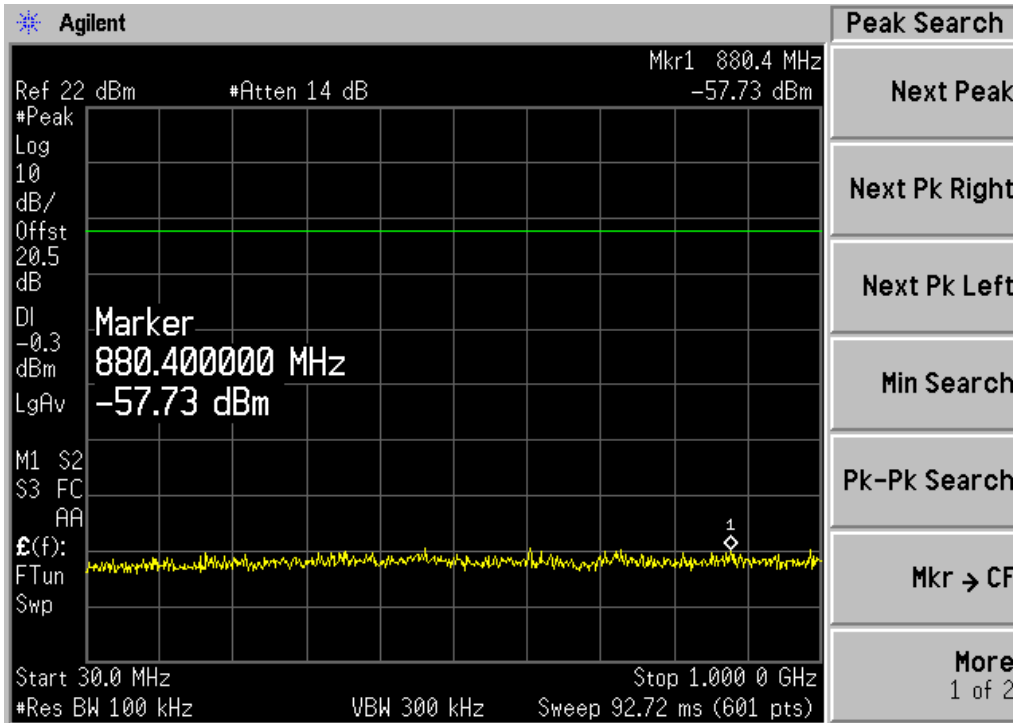

SPURIOUS EMISSIONS, MID CHANNEL

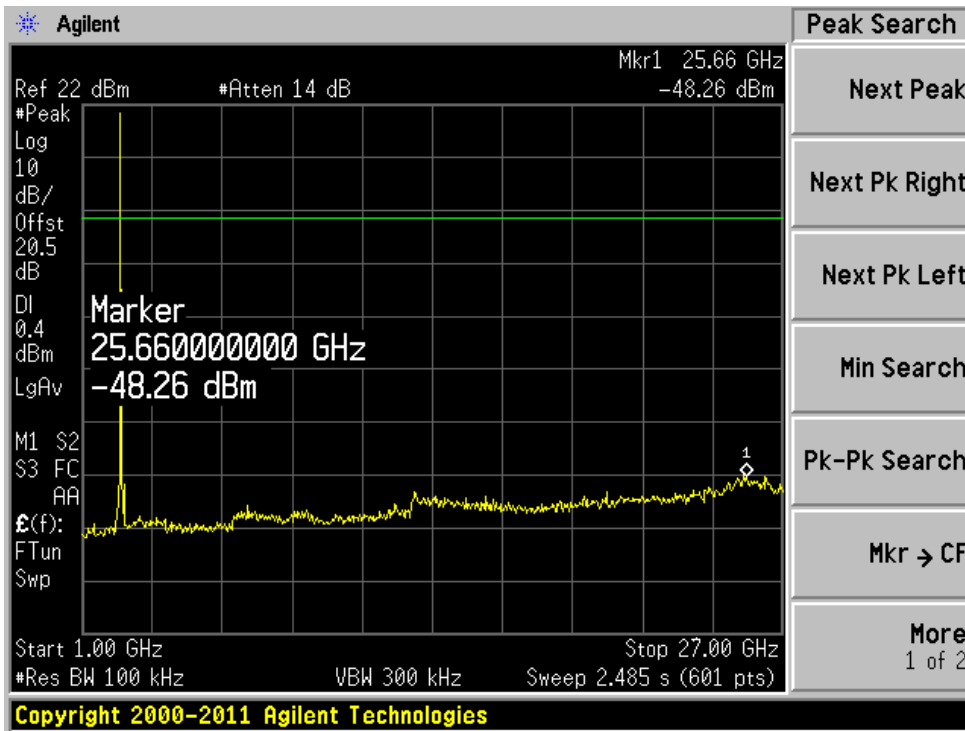
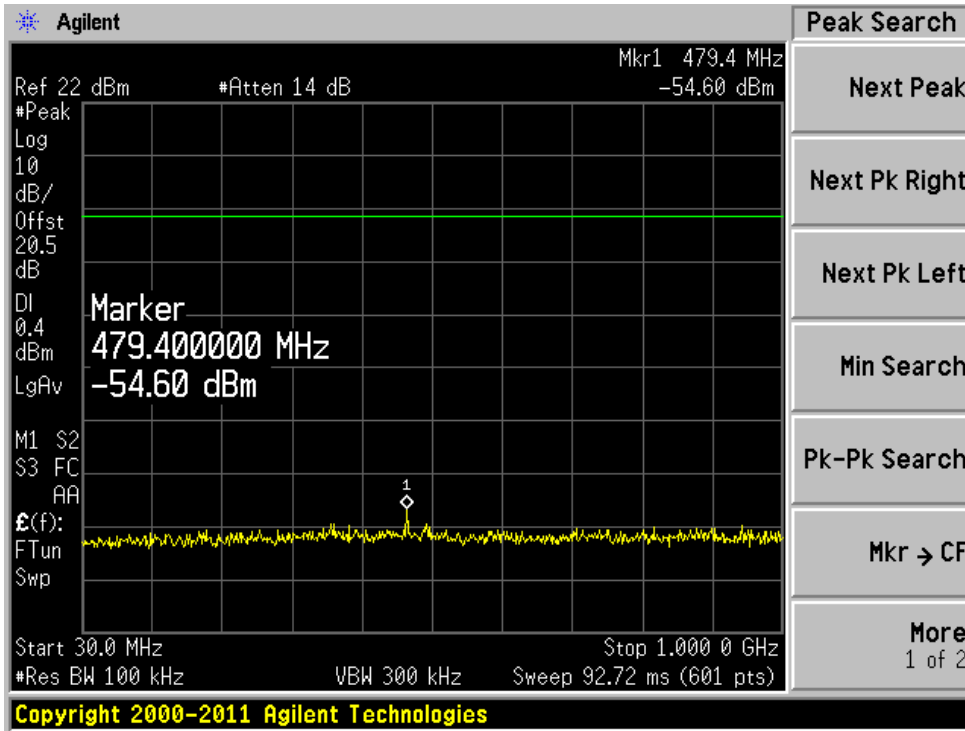

SPURIOUS EMISSIONS, HIGH CHANNEL

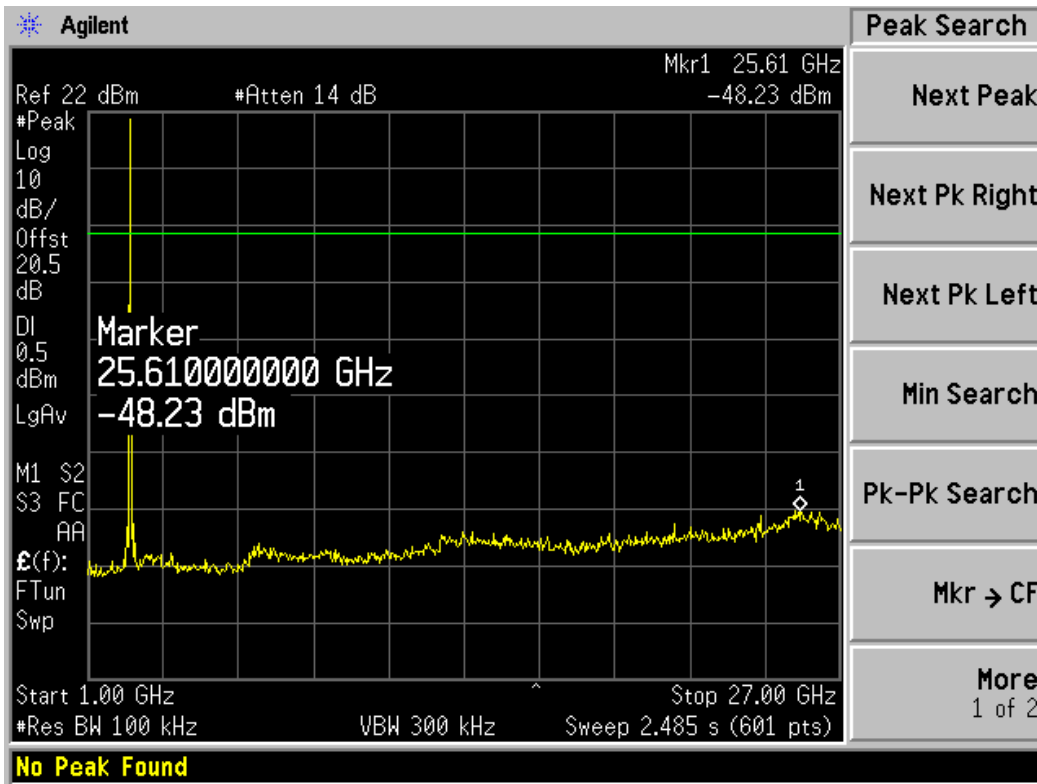
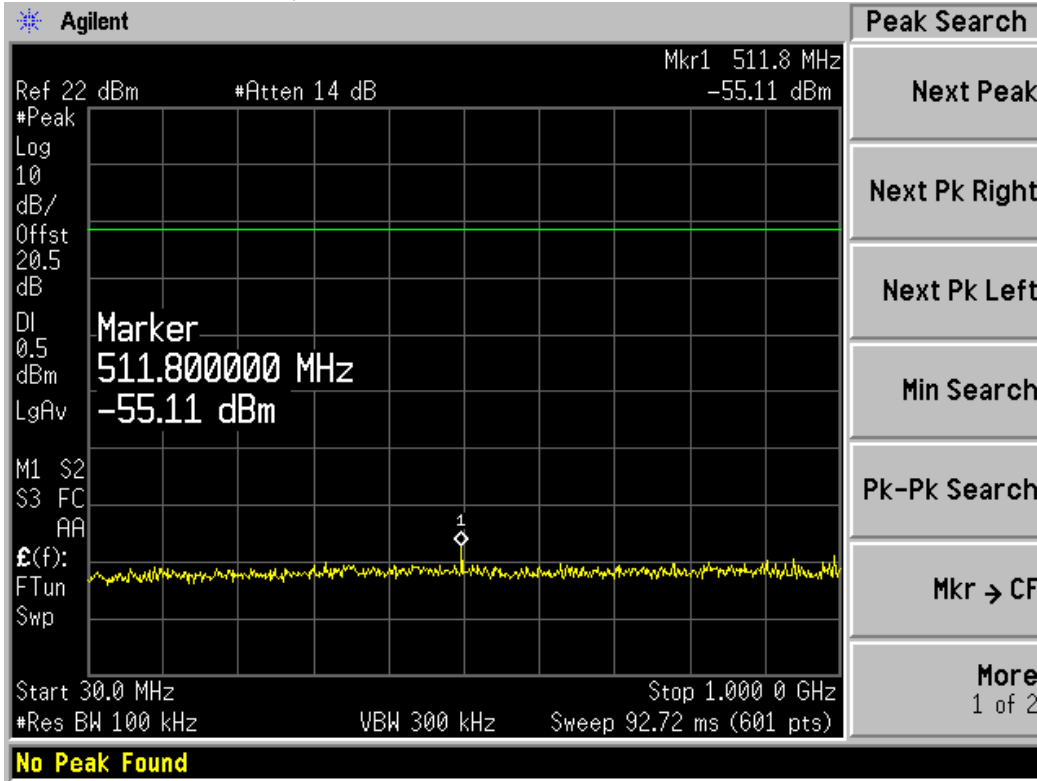

4.4 POWERLINE CONDUCTED EMISSIONS

LIMIT

§15.207 (a) Except as shown in paragraphs (b) and (c) of this section, for an intentional radiator that is designed to be connected to the public utility (AC) power line, the radio frequency voltage that is conducted back onto the AC power line on any frequency or frequencies within the band 150 kHz to 30 MHz shall not exceed the limits in the following table, as measured using a 50 μ H/50 ohms line impedance stabilization network (LISN). Compliance with the provisions of this paragraph shall be based on the measurement of the radio frequency voltage between each power line and ground at the power terminal.

The lower limit applies at the boundary between the frequency ranges.

Frequency of Emission (MHz)	Conducted Limit (dBuV)	
	Quasi-peak	Average
0.15-0.5	66 to 56	56 to 46
0.5-5	56	46
5-30	60	50

*Decreases with the logarithm of the frequency.

TEST PROCEDURE

The EUT is placed on a non-conducting table 40 cm from the vertical ground plane and 80 cm above the horizontal ground plane. The EUT is configured in accordance with ANSI C63.4.

The resolution bandwidth is set to 9 kHz for both peak detection and quasi-peak detection measurements. Peak detection is used unless otherwise noted as quasi-peak.

The transmitter was configured to simultaneously transmit FHSS mode in the 902 MHz and 2.4 GHz bands simultaneously, since this is the worst case operation (maximum output power) for simultaneous operation.

Line conducted data is recorded for both NEUTRAL and HOT lines.

RESULTS

No non-compliance noted:

Neutral AC Conducted Emissions

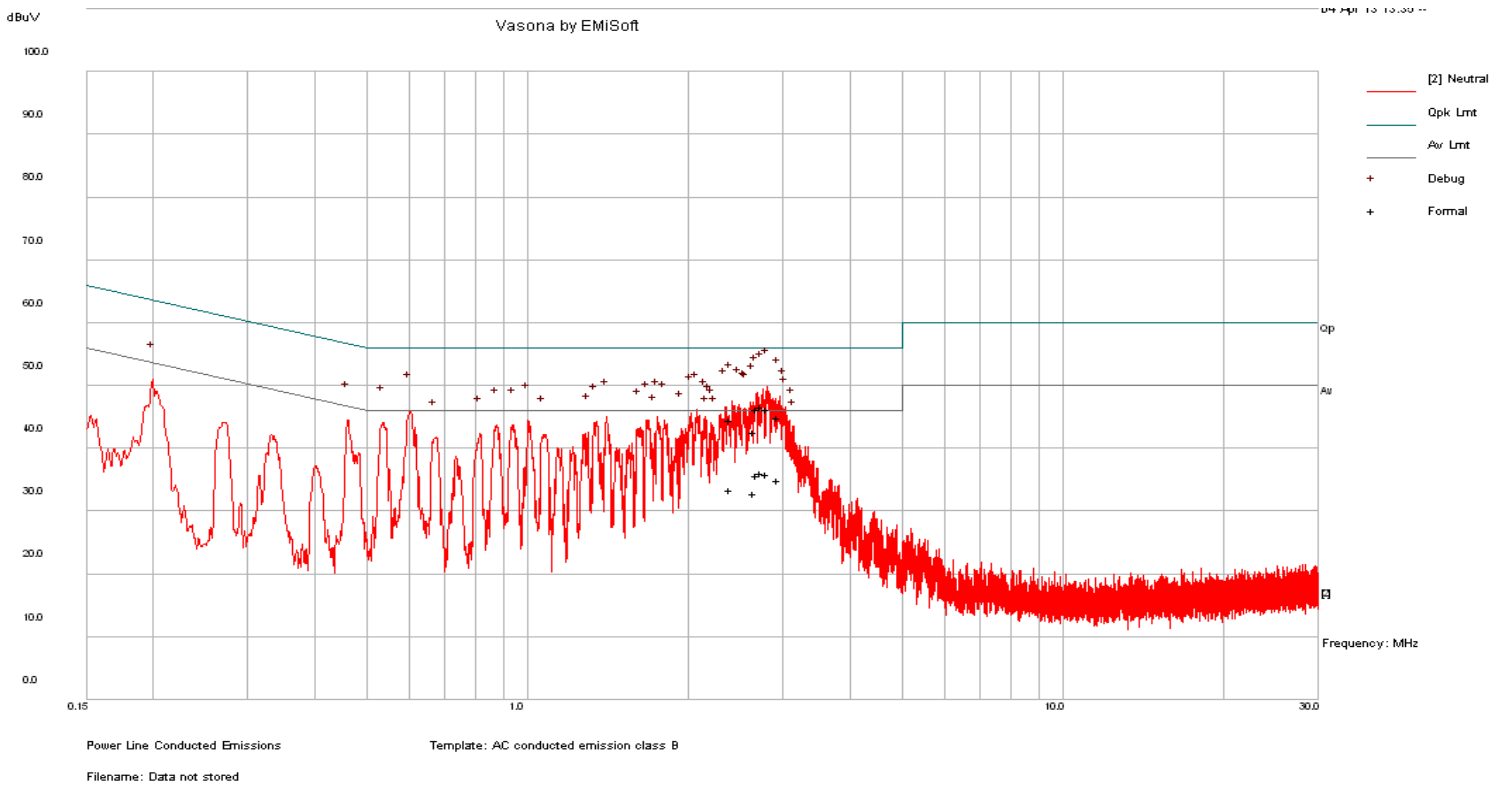

Hot AC Line Conducted Emissions

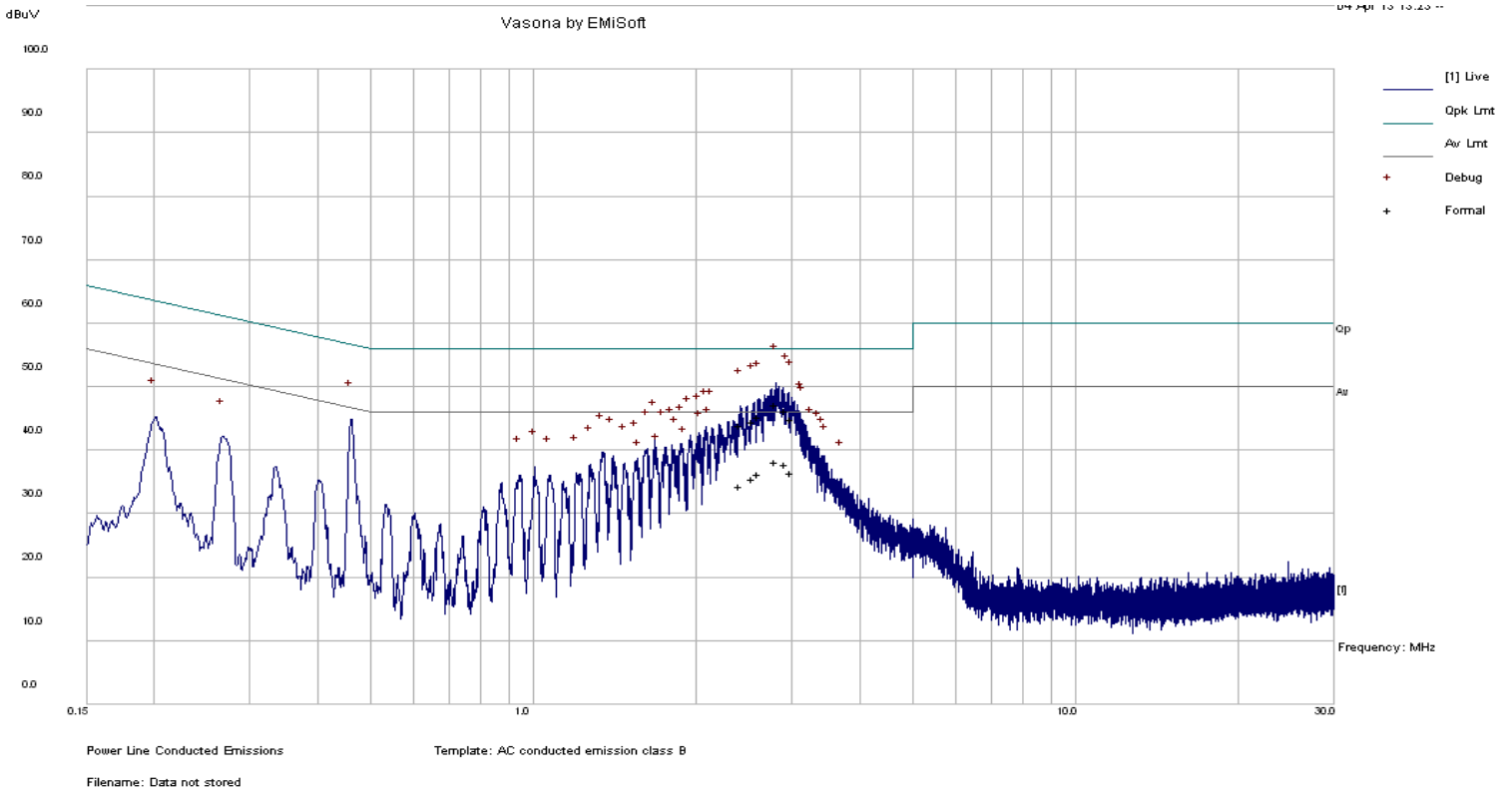

Tabulated worst case AC line conducted data

Vasona Data : Formally Assessed Peaks

No	Frequency	MFRaw	dBuV	Cable	Loss	Factors	dB	Level	dBuV	Measurement	Line	Limit	dBuV	Margin	dB
1	2.814417		37.2		9.85		0.17		47.22	Quasi Peak	Line	56		-8.78	
2	2.934367		36.26		9.86		0.17		46.28	Quasi Peak	Line	56		-9.72	
3	2.999114		34.9		9.86		0.17		44.93	Quasi Peak	Line	56		-11.07	
4	2.614229		35.28		9.84		0.16		45.29	Quasi Peak	Line	56		-10.71	
5	2.551766		34.55		9.83		0.16		44.55	Quasi Peak	Line	56		-11.45	
6	2.41332		33.94		9.83		0.16		43.92	Quasi Peak	Line	56		-12.08	
7	2.814417		28.21		9.85		0.17		38.22	Average	Line	46		-7.78	
8	2.934367		27.77		9.86		0.17		37.8	Average	Line	46		-8.2	
9	2.999114		26.56		9.86		0.17		36.59	Average	Line	46		-9.41	
10	2.614229		26.38		9.84		0.16		36.38	Average	Line	46		-9.62	
11	2.551766		25.48		9.83		0.16		35.48	Average	Line	46		-10.52	
12	2.41332		24.45		9.83		0.16		34.44	Average	Line	46		-11.56	

Vasona Data : Formally Assessed Peaks

No	Frequency	MFRaw	dBuV	Cable	Loss	Factors	dB	Level	dBuV	Measurement	Line	Limit	dBuV	Margin	dB
1	2.814032		36.17		9.85		0.17		46.19	Quasi Peak	Neutral	56		-9.81	
2	2.733335		36.62		9.84		0.16		46.63	Quasi Peak	Neutral	56		-9.37	
3	2.68197		36.21		9.84		0.16		46.22	Quasi Peak	Neutral	56		-9.78	
4	2.948367		34.83		9.86		0.17		44.85	Quasi Peak	Neutral	56		-11.15	
5	2.402721		34.51		9.82		0.16		44.49	Quasi Peak	Neutral	56		-11.51	
6	2.649245		32.58		9.84		0.16		42.58	Quasi Peak	Neutral	56		-13.42	
7	2.814032		25.95		9.85		0.17		35.97	Average	Neutral	46		-10.03	
8	2.733335		26.2		9.84		0.16		36.21	Average	Neutral	46		-9.79	
9	2.68197		25.65		9.84		0.16		35.65	Average	Neutral	46		-10.35	
10	2.948367		24.89		9.86		0.17		34.91	Average	Neutral	46		-11.09	
11	2.402721		23.45		9.82		0.16		33.44	Average	Neutral	46		-12.56	
12	2.649245		22.78		9.84		0.16		32.79	Average	Neutral	46		-13.21	

END OF REPORT

Report Revision History

Revision No.	Revision Description	Pages Revised	Revised by	Date
-	Original issue		T. Cokenias	7 April 2013