

Test of Silver Spring Network MicroAP
To: FCC 47 CFR Part15.247 & IC RSS-210
Test Report Serial No.: SSNT62-U2 Rev A



TEST REPORT

FROM



Test of Silver Spring Network MicroAP

To FCC 47 CFR Part15.247 & IC RSS-210

Test Report Serial No.: SSNT62-U2 Rev A

This report supersedes: NONE

Manufacturer: Silver Spring Networks
555 Broadway Street
Redwood City
California 94063, USA

Product Function: Micromesh allows machine to machine communication over 900 MHz and 2.4 GHz FHSS and transmit data over 3G GSM or CDMA cellular backhaul to utility or network provider. 2.4 GHz home area network paring with other Zigbee devices.

Copy No: pdf **Issue Date:** 13th August 2013

This Test Report is Issued Under the Authority of;

MiCOM Labs, Inc.
440 Boulder Court, Suite 200
Pleasanton, CA 94566 USA
Phone: +1 (925) 462-0304
Fax: +1 (925) 462-0306
www.micomlabs.com



TEST CERTIFICATE #2381.01

MiCOM Labs is an ISO 17025 Accredited Testing Laboratory



Title: Silver Spring Network MicroAP
To: FCC 47 CFR Part15.247 & IC RSS-210
Serial #: SSNT62-U2 Rev A
Issue Date: 13th August 2013
Page: 3 of 147

This page has been left intentionally blank

This test report may be reproduced in full only. The document may only be updated by MiCOM Labs personnel. Any changes will be noted in the Document History section of the report.



TABLE OF CONTENTS

ACCREDITATION, LISTINGS & RECOGNITION	5
TESTING ACCREDITATION	5
RECOGNITION.....	6
PRODUCT CERTIFICATION.....	7
1. TEST RESULT CERTIFICATE	9
2. REFERENCES AND MEASUREMENT UNCERTAINTY	10
2.1. Normative References	10
2.2. Test and Uncertainty Procedures	10
3. PRODUCT DETAILS AND TEST CONFIGURATIONS	11
3.1. Technical Details	11
3.2. Scope of Test Program.....	12
3.3. Equipment Model(s) and Serial Number(s)	14
3.4. Antenna Details	14
3.5. Cabling and I/O Ports	14
3.6. Test Configurations.....	15
3.7. Equipment Modifications.....	15
3.8. Deviations from the Test Standard	15
4. TEST EQUIPMENT CONFIGURATION(S)	16
4.1. Conducted RF Emission Test Set-up	16
4.2. Radiated Spurious Emission Test Set-Up > 1 GHz	17
4.3. Digital Emissions Test Set-Up (0.03 – 1 GHz).....	18
5. TEST SUMMARY	19
6. TEST RESULTS	21
6.1. Device Characteristics	21
6.1.1. 20 dB and 99% Bandwidth.....	21
6.1.2. FHSS Transmitter Characteristics.....	29
6.1.3. Output Power	55
6.1.4. Conducted Spurious Emissions Transmitter	63
6.1.5. Radiated Emissions > 1 GHz.....	71
6.1.6. Radiated Spurious Emissions – Digital Emissions (0.03-1 GHz).....	88
6.1.7. AC Wireline Conducted Emissions (150 kHz – 30 MHz)	92
7. PHOTOGRAPHS.....	94
7.1. General Measurement Test Set-Up	94
7.2. Radiated Emissions <1 GHz.....	95
7.3. Radiated Emissions >1 GHz.....	96
8. TEST EQUIPMENT DETAILS.....	97
APPENDIX.....	98
A. SUPPORTING INFORMATION	98
A.1. CONDUCTED TEST PLOTS.....	98
A.1.1. 20 dB & 99% Bandwidth	99
A.1.2. Conducted Spurious and Band-Edge Emissions	117

This test report may be reproduced in full only. The document may only be updated by MiCOM Labs personnel. Any changes will be noted in the Document History section of the report.

ACCREDITATION, LISTINGS & RECOGNITION

TESTING ACCREDITATION

MiCOM Labs, Inc. is an accredited Electrical testing laboratory per the international standard EN ISO/IEC 17025. The company is accredited by the American Association for Laboratory Accreditation (A2LA) www.a2la.org test laboratory number 2381.01. MiCOM Labs test schedule is available at the following URL; <http://www.a2la.org/scopepdf/2381-01.pdf>



The American Association for Laboratory Accreditation

World Class Accreditation

Accredited Laboratory

A2LA has accredited

MICOM LABS

Pleasanton, CA

for technical competence in the field of

Electrical Testing

This laboratory is accredited in accordance with the recognized International Standard ISO/IEC 17025:2005 *General Requirements for the Competence of Testing and Calibration Laboratories*. This accreditation demonstrates technical competence for a defined scope and the operation of a laboratory quality management system (refer to joint ISO-ILAC-IAF Communiqué dated 8 January 2009).

Presented this 27th day of March 2012.

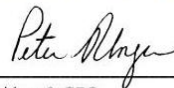

President & CEO
For the Accreditation Council
Certificate Number 2381.01
Valid to November 30, 2013

For the tests or types of tests to which this accreditation applies, please refer to the laboratory's Electrical Scope of Accreditation.

This test report may be reproduced in full only. The document may only be updated by MiCOM Labs personnel. Any changes will be noted in the Document History section of the report.



RECOGNITION

MiCOM Labs, Inc has widely recognized Electrical testing capabilities. Our international recognition includes Conformity Assessment Body designation by APEC MRA** countries. Our test reports are widely accepted for global type approvals.

Country	Recognition Body	Status	Phase	Identification No.
USA	Federal Communications Commission (FCC)	TCB	-	US0159 Listing #: 102167
Canada	Industry Canada (IC)	FCB	APEC MRA 2	US0159 Listing #: 4143A-2
Japan	MIC (Ministry of Internal Affairs and Communication)	CAB	APEC MRA 2	RCB 210
	VCCI	--	--	A-0012
Europe	European Commission	NB	EU MRA	NB 2280
Australia	Australian Communications and Media Authority (ACMA)	CAB	APEC MRA 1	US0159
Hong Kong	Office of the Telecommunication Authority (OFTA)	CAB	APEC MRA 1	
Korea	Ministry of Information and Communication Radio Research Laboratory (RRL)	CAB	APEC MRA 1	
Singapore	Infocomm Development Authority (IDA)	CAB	APEC MRA 1	
Taiwan	National Communications Commission (NCC) Bureau of Standards, Metrology and Inspection (BSMI)	CAB	APEC MRA 1	
Vietnam	Ministry of Communication (MIC)	CAB	APEC MRA 1	

**APEC MRA – Asia Pacific Economic Community Mutual Recognition Agreement.

Is a recognition agreement under which test lab is accredited to regulatory standards of the APEC member countries.

Phase I - recognition for product testing

Phase II – recognition for both product testing and certification

N/A – Not Applicable

**EU MRA – European Union Mutual Recognition Agreement.

Is a recognition agreement under which test lab is accredited to regulatory standards of the EU member countries.

**NB – Notified Body

This test report may be reproduced in full only. The document may only be updated by MiCOM Labs personnel. Any changes will be noted in the Document History section of the report.

PRODUCT CERTIFICATION

MiCOM Labs, Inc. is an accredited Product Certification Body per the international standard EN ISO/IEC Guide 65. The company is accredited by the American Association for Laboratory Accreditation (A2LA) www.a2la.org test laboratory number 2381.02. MiCOM Labs test schedule is available at the following URL; <http://www.a2la.org/scopepdf/2381-02.pdf>



The American Association for Laboratory Accreditation

Accredited Product Certification Body

A2LA has accredited

MICOM LABS

Pleasanton, CA

for technical competence as a

Product Certification Body

This product certification body is accredited in accordance with the recognized International Standard ISO/IEC Guide 65:1996 *General requirements for bodies operating product certification systems*. This accreditation demonstrates technical competence for a defined scope and the operation of a quality management system.

Presented this 27th day of March 2012.



President & CEO
For the Accreditation Council
Certificate Number 2381.02
Valid to November 30, 2013

For the product certification schemes to which this accreditation applies, please refer to the organization's Product Certification Scope of Accreditation

United States of America – Telecommunication Certification Body (TCB)

TCB Identifier – US0159

Industry Canada – Certification Body

CAB Identifier – US0159

Europe – Notified Body

Notified Body Identifier - 2280

Japan – Recognized Certification Body (RCB)

RCB Identifier - 210

This test report may be reproduced in full only. The document may only be updated by MiCOM Labs personnel. Any changes will be noted in the Document History section of the report.



Title: Silver Spring Network MicroAP
To: FCC 47 CFR Part15.247 & IC RSS-210
Serial #: SSNT62-U2 Rev A
Issue Date: 13th August 2013
Page: 8 of 147

DOCUMENT HISTORY

Document History		
Revision	Date	Comments
Draft		
Rev A	13 th August 2013	Initial release.

This test report may be reproduced in full only. The document may only be updated by MiCOM Labs personnel. Any changes will be noted in the Document History section of the report.



Title: Silver Spring Network MicroAP
To: FCC 47 CFR Part15.247 & IC RSS-210
Serial #: SSNT62-U2 Rev A
Issue Date: 13th August 2013
Page: 9 of 147

1. TEST RESULT CERTIFICATE

Manufacturer: Silver Spring Networks 555 Broadway Street Redwood City California 94063, USA	Tested By: MiCOM Labs, Inc. 440 Boulder Court Suite 200 Pleasanton California, 94566, USA
EUT: Network Interface Card (NIC)	Telephone: +1 925 462 0304
Model: MicroAP (NIC 411-3G, NIC 411-3C)	Fax: +1 925 462 0306
S/N: mac:00:13:50:02:00:a6:ff:bd	
Test Date(s): 3rd July to 12th August 2013	Website: www.micomlabs.com

STANDARD(S)	TEST RESULTS
FCC 47 CFR Part15.247 & IC RSS-210	EQUIPMENT COMPLIES

MiCOM Labs, Inc. tested the equipment mentioned in accordance with the requirements set forth in the above standards. Test results indicate that the equipment tested is capable of demonstrating compliance with the requirements as documented within this report.

Notes:

1. This document reports conditions under which testing was conducted and the results of testing performed.
2. Details of test methods used have been recorded and kept on file by the laboratory.
3. Test results apply only to the item(s) tested.

Approved & Released for MiCOM Labs, Inc. by:



TEST CERTIFICATE #2381.01



Graeme Grieve
Quality Manager MiCOM Labs,



Gordon Hurst
President & CEO MiCOM Labs, Inc.

This test report may be reproduced in full only. The document may only be updated by MiCOM Labs personnel. Any changes will be noted in the Document History section of the report.

2. REFERENCES AND MEASUREMENT UNCERTAINTY

2.1. Normative References

Ref.	Publication	Year	Title
(i)	FCC 47 CFR Part 15.247	2012	Code of Federal Regulations
(ii)	Industry Canada RSS-210	Issue 8 Dec 2010	Low Power License-Exempt Radiocommunication Devices (All Frequency Bands)
(iii)	Industry Canada RSS-Gen	Issue 3 Jan 2012	General Requirements and Information for the Certification of Radiocommunication Equipment.
(iv)	ANSI C63.4	2009	American National Standards for Methods of Measurement of Radio-Noise Emissions from Low-Voltage Electrical and Electronic Equipment in the Range of 9 kHz to 40 GHz
(v)	CISPR 22/ EN 55022	2008 2006+A1:2 007	Limits and Methods of Measurements of Radio Disturbance Characteristics of Information Technology Equipment
(vi)	M 3003	Edition 2. Jan 2007	Expression of Uncertainty and Confidence in Measurements
(vii)	LAB34	Edition 1 Aug 2002	The expression of uncertainty in EMC Testing
(viii)	ETSI TR 100 028	2001	Parts 1 and 2 Electromagnetic compatibility and Radio Spectrum Matters (ERM); Uncertainties in the measurement of mobile radio equipment characteristics
(ix)	A2LA	July 2012	Reference to A2LA Accreditation Status – A2LA Advertising Policy

2.2. Test and Uncertainty Procedures

Conducted and radiated emission measurements were conducted in accordance with American National Standards Institute ANSI C63.4, listed in the Normative References section of this report.

Measurement uncertainty figures are calculated in accordance with ETSI TR 100 028 Parts 1 and 2.

Measurement uncertainties stated are based on a standard uncertainty multiplied by a coverage factor $k = 2$, providing a level of confidence of approximately 95 % in accordance with UKAS document M 3003 listed in the Normative References section of this report.



Title: Silver Spring Network MicroAP
To: FCC 47 CFR Part15.247 & IC RSS-210
Serial #: SSNT62-U2 Rev A
Issue Date: 13th August 2013
Page: 11 of 147

3. PRODUCT DETAILS AND TEST CONFIGURATIONS

3.1. Technical Details

Details	Description
Purpose:	Test of the Silver Spring Network MicroAP (NIC 411-3G, NIC 411-3C) to FCC Part 15.247 and Industry Canada RSS-210 regulations
Applicant:	As Manufacturer
Manufacturer:	Silver Spring Networks 555 Broadway Street Redwood City California 94063, USA
Laboratory performing the tests:	MiCOM Labs, Inc. 440 Boulder Court, Suite 200 Pleasanton, California 94566 USA
Test report reference number:	SSNT62-U2 Rev A
Standard(s) applied:	FCC 47 CFR Part15.247 & IC RSS-210
Date EUT received:	3 rd July 2013
Dates of test (from - to):	3rd July to 12th August 2013
No of Units Tested:	One
Type of Equipment:	Network Interface Card (NIC)
Manufacturers Trade Name:	MicroAP
Model:	NIC 411-3G-070B, NIC 411-3G-0713, NIC 411-070A, NIC 411-3G-0712, NIC 411-3C-070B, NIC 411-3C-0713, NIC 411-3C-070A, NIC 411-3C-0712
Location for use:	Indoor/Outdoor
Declared Frequency Range(s):	902 – 928 MHz 2400 – 2483.5 MHz
Type of Modulation:	900 MHz: FSK & GFSK 2400 MHz: GFSK
Declared Nominal Output Power:	902-928 MHz :+30 dBm 2400 – 2483.5 MHz 27 dBm
EUT Modes of Operation:	FHSS
Transmit/Receive Operation:	Transceiver, Simplex
Rated Input Voltage:	Nominal Voltage 4 Vdc
Operating Temperature Range:	-40°C to +85°C (client declared range)
ITU Emission Designator(s):	900 MHz 100 kbps FSK: 200KF1D 900 MHz 100 kbps GFSK: 120KF1D 900 MHz 150 kbps GFSK: 170KF1D 900 MHz 300 kbps GFSK: 320KF1D 2.4 GHz 250 kbps GFSK: 280KF1D 2.4 GHz 500 kbps GFSK: 530KF1D
EUT Dimensions:	108.2x46.99x14.22 (mm)
EUT Weight :	39 grams
Primary function of equipment:	Micromesh allows machine to machine communication over 900 MHz and 2.4 GHz FHSS and transmit data over 3G GSM or CDMA cellular backhaul to utility or network provider. 2.4 GHz home area network paring with other Zigbee devices.

This test report may be reproduced in full only. The document may only be updated by MiCOM Labs personnel. Any changes will be noted in the Document History section of the report.



3.2. Scope of Test Program

The scope of the test program was to test the Silver Spring Network MicroAP (NIC 411-3G, NIC 411-3C) and the NIC411-3C-070B/0713 in the frequency ranges 902 - 928 and 2400 – 2483.5 MHz against FCC 47 CFR Part 15.247 and Industry Canada RSS-210 specifications for radiated and conducted emissions for intentional radiators. The intentional radiator was tested in a simulated typical installation to demonstrate compliance with the stated standards.

Co-Location Testing

Co-location measurements were performed on the cellular frequency bands together with the 915 MHz and 2.4 GHz DSSS and FHSS technologies. Test results are available and will be kept on file by the laboratory.

Model Number Differences

NIC 411-3G-070B: 900 MHz FHSS NAN1, 2.4 GHz HAN, 2.4 GHz NAN2, 3G GSM cellular module, internal/external NAN antenna and internal cell antenna

NIC 411-3G-0713: 900 MHz FHSS NAN1, 2.4 GHz HAN, 2.4 GHz NAN2, 3G GSM cellular module, internal/external NAN antenna and external cell antenna

NIC 411-3G-070A: 900 MHz FHSS NAN1, 2.4 GHz HAN, 2.4 GHz NAN2, 3G GSM cellular module, external NAN antenna and internal cell antenna

NIC 411-3G-0712: 900 MHz FHSS NAN1, 2.4 GHz HAN, 2.4 GHz NAN2, 3G GSM cellular module, external NAN antenna and external cell antenna

NIC 411-3C-070B: 900 MHz FHSS NAN1, 2.4 GHz HAN, 2.4 GHz NAN2, CDMA-2000 cellular module, internal/external NAN antenna and internal cell antenna

NIC 411-3C-0713: 900 MHz FHSS NAN1, 2.4 GHz HAN, 2.4 GHz NAN2, CDMA-2000 cellular module, internal/external NAN antenna and external cell antenna

NIC 411-3C-070A: 900 MHz FHSS NAN1, 2.4 GHz HAN, 2.4 GHz NAN2, CDMA-2000 cellular module, external NAN antenna and internal cell antenna

NIC 411-3C-0712: 900 MHz FHSS NAN1, 2.4 GHz HAN, 2.4 GHz NAN2, CDMA-2000 cellular module, external NAN antenna and external cell antenna

NAN1: 900 MHz FHSS

NAN2: 2.4 GHz FHSS

HAN: 2.4 GHz DSSS (802.15.4 Zigbee)

This test report may be reproduced in full only. The document may only be updated by MiCOM Labs personnel. Any changes will be noted in the Document History section of the report.



Antenna Options

The MicroAP (NIC 411-3G, NIC 411-3C) has two antenna options integral and external, both options were tested. As cellular operation was provided via plug-in module(s) which have their own FCC and IC certification no cellular testing was required.

The MicroAP (NIC 411-3G, NIC 411-3C) operated with the following modulations and data rates, each modulation and data rate was tested during the program. Results for the external antenna are included in this report.

Frequency Band	Modulation	Data Rate
902 – 928 MHz	FSK	100 kBit/s
	GFSK	100 kBit/s
	GFSK	150 kBit/s
	GFSK	300 kBit/s
2400 -2483.5 MHz	GFSK	250 kBit/s
	GFSK	500 kBit/s



Title: Silver Spring Network MicroAP
To: FCC 47 CFR Part15.247 & IC RSS-210
Serial #: SSNT62-U2 Rev A
Issue Date: 13th August 2013
Page: 14 of 147

3.3. Equipment Model(s) and Serial Number(s)

Type (EUT/Support)	Equipment Description (Including Brand Name)	Mfr	Model No.	Serial No.
EUT	Network Interface Card	Silver Spring Network	MicroAP (NIC 411-3G, NIC 411-3C)	mac:00:13:50:02:00:a6:ff:bd
Support	Laptop	IBM	ThinkPad	None

3.4. Antenna Details

Manufacturer	Model	Internal/External	Frequency	Antenna Gain
F-Type	155-0010-00	Internal	900 MHz	1.2
F-Type	155-0010-00	Internal	2.4 GHz	5.6
SMD	A10376	Internal	824-960 MHz (cellular)	-1.2*
SMD	A10376	Internal	1710-1990 MHz (cellular)	-1.9*
Omni	WPANT30017-CA	External	902-928 MHz	3.0
Omni	WPANT30017-CA	External	2.4-2.5 GHz	4.0

*Module pre-certified no testing performed on this technology

3.5. Cabling and I/O Ports

Number and type of I/O ports

1. NONE

This test report may be reproduced in full only. The document may only be updated by MiCOM Labs personnel. Any changes will be noted in the Document History section of the report.



3.6. Test Configurations

Test configurations

Frequency Band	Modulation	Data Rate (kBit/s)	Channel Center Frequency (MHz)
902 – 928 MHz	FSK	100	902.3, 915.2, 927.8
	GFSK	100	902.2, 915.0, 927.8
	GFSK	150	902.3, 915.2, 927.8
	GFSK	300	902.4, 915.2, 927.6
2400 -2483.5 MHz	GFSK	250	2400.8,2440.0,2472.8
	GFSK	500	2400.8,2440.0,2472.8

3.7. Equipment Modifications

The following modifications were required to bring the equipment into compliance:

1. NONE

3.8. Deviations from the Test Standard

The following deviations from the test standard were required in order to complete the test program:

1. NONE

4. TEST EQUIPMENT CONFIGURATION(S)

4.1. Conducted RF Emission Test Set-up

The following tests were performed using the conducted test set-up shown in the diagram below.

1. Section 6.1.1. 20 dB and 99% Bandwidth
2. Section 6.1.2. Transmitter Channels – Channel Spacing
3. Section 6.1.3. Transmitter Channels
4. Section 6.1.4. Output Power

Conducted Test Set-Up Pictorial Representation

Test Measurement set up

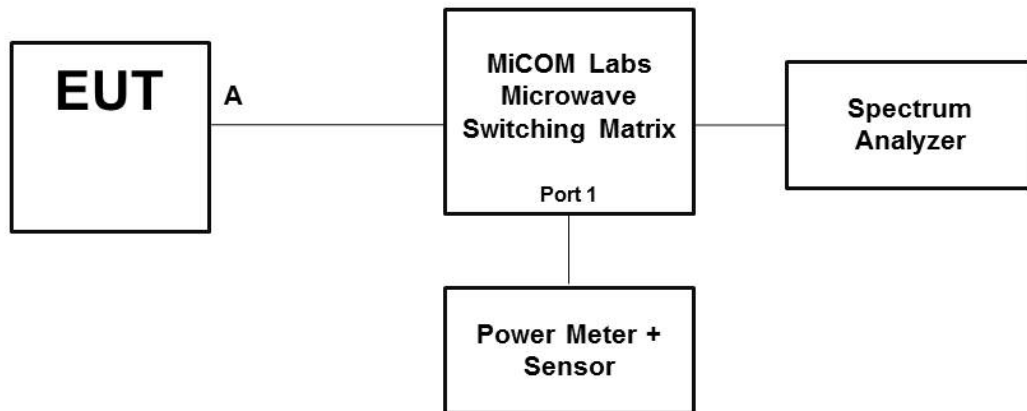

Conducted Test Measurement Setup

This test report may be reproduced in full only. The document may only be updated by MiCOM Labs personnel. Any changes will be noted in the Document History section of the report.

4.2. Radiated Spurious Emission Test Set-Up > 1 GHz

The following tests were performed using the conducted test set-up shown in the diagram below.

Section 6.1.8 Radiated Emissions

Radiated Emission Measurement Setup – Above 1 GHz

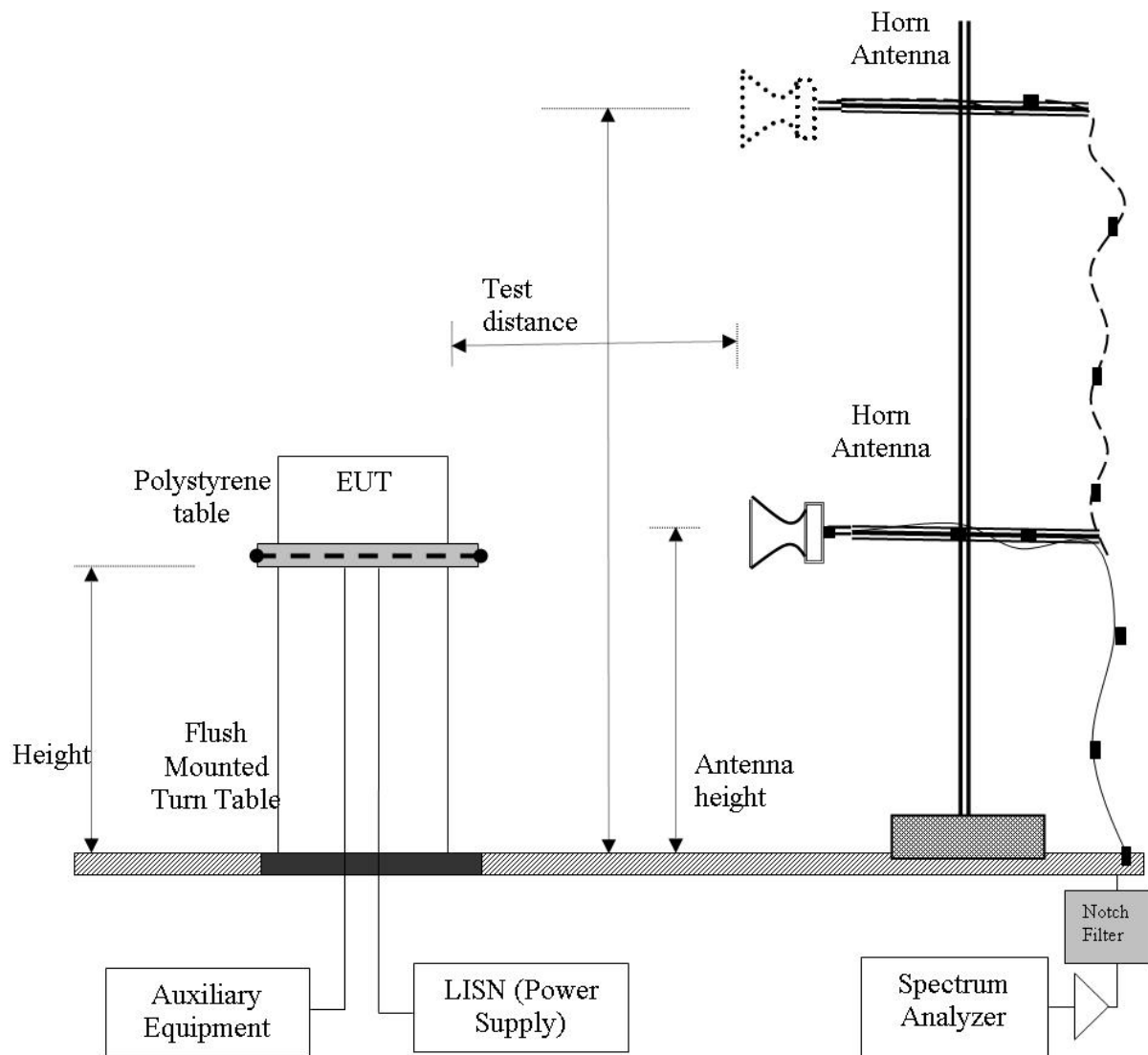

This test report may be reproduced in full only. The document may only be updated by MiCOM Labs personnel. Any changes will be noted in the Document History section of the report.

4.3. Digital Emissions Test Set-Up (0.03 – 1 GHz)

The following tests were performed using the conducted test set-up shown in the diagram below.

Section 6.1.9 Radiated Spurious Emissions – Digital Emissions (0.03 – 1 GHz)

Digital Emission Measurement Setup – Below 1 GHz

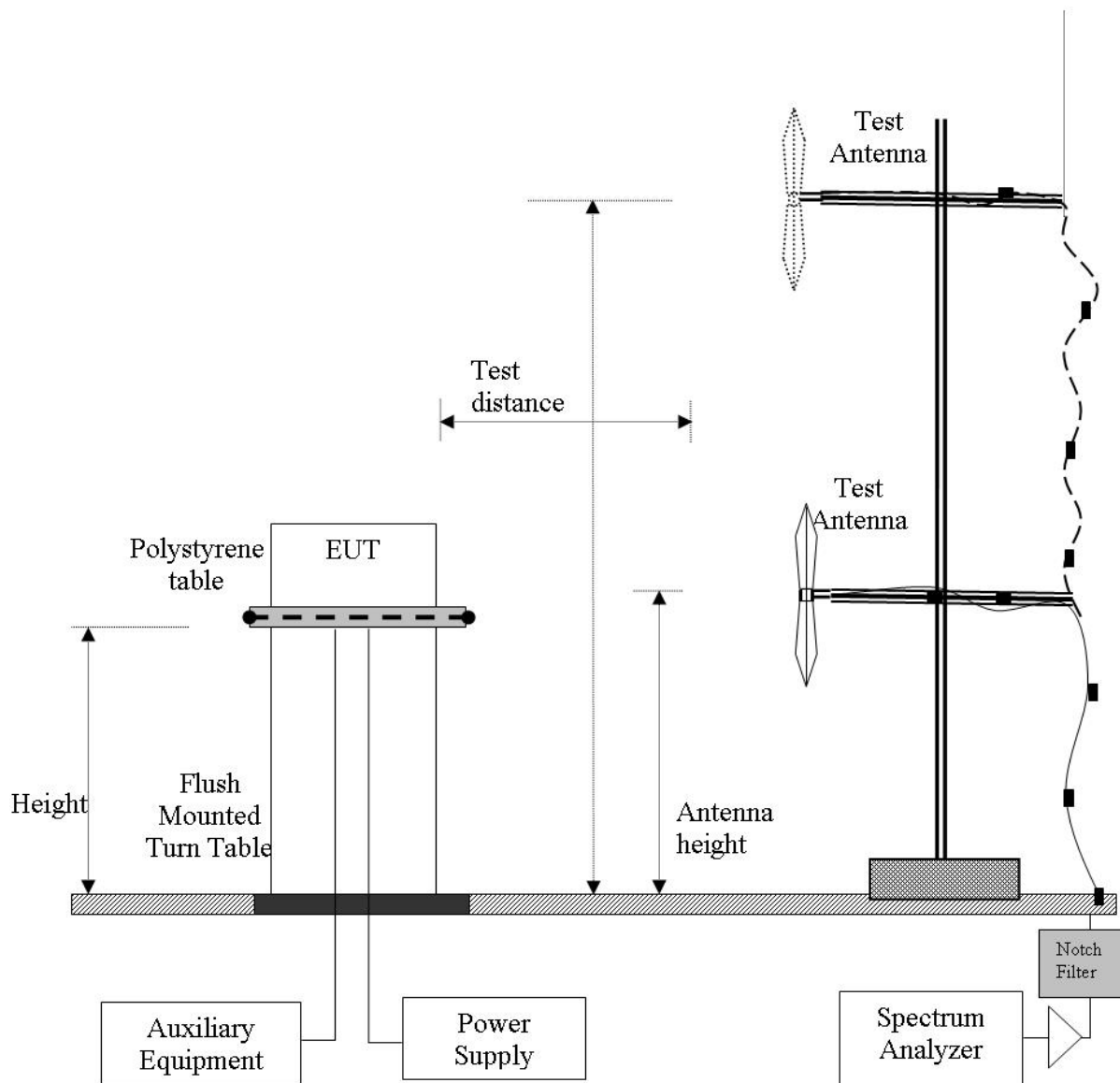

This test report may be reproduced in full only. The document may only be updated by MiCOM Labs personnel. Any changes will be noted in the Document History section of the report.



5. TEST SUMMARY

List of Measurements

The following table represents the list of measurements required under the **FCC CFR47 Part 15.247**, **Industry Canada RSS-210** and **Industry Canada RSS-Gen**.

Section(s)	Test Items	Description	Condition	Result	Test Report Section
15.247(a)(1) A8.1	20 dB & 99% BW	Bandwidths	Conducted	Complies	6.1.1
15.247(a)(1) A8.1	Transmitter Channels	Channel Spacing	Conducted	Complies	6.1.2
15.247(a)(1) A8.1	Transmitter Channels	Number of Channels	Conducted	Complies	6.1.3.1
		Channel Occupancy	Conducted	Complies	6.1.3.2
15.247(b)(2) A8.4	Output Power	Transmit Power	Conducted	Complies	6.1.4
15.247(i) 5.5	Maximum Permissible Exposure	Exposure to radio frequency energy levels	Conducted	Complies	6.1.5
15.247(d) A8.5	Conducted Spurious Emissions	Band Edge	Conducted	Complies	6.1.6
		Spurious Emissions Transmitter (1 to 10 GHz)	Conducted	Complies	

This test report may be reproduced in full only. The document may only be updated by MiCOM Labs personnel. Any changes will be noted in the Document History section of the report.



Title: Silver Spring Network MicroAP
To: FCC 47 CFR Part15.247 & IC RSS-210
Serial #: SSNT62-U2 Rev A
Issue Date: 13th August 2013
Page: 20 of 147

List of Measurements

The following table represents the list of measurements required under the **FCC CFR47 Part 15.247**, **Industry Canada RSS-210** and **Industry Canada RSS-Gen**.

Section(s)	Test Items	Description	Condition	Result	Test Report Section
15.247(d) 15.205 15.209 A8.5 2.2 2.6 4.9	Radiated Emissions above 1 GHz	Transmitter	Radiated	Complies	6.1.7
15.247(d) 15.205 15.209 A8.5 2.2 2.6	Radiated Emissions below 1 GHz		Radiated	Complies	6.1.8
15.207 7.2.2	Conducted	AC Wireline Conducted Emissions	Conducted	Test not applicable EUT was dc powered	6.1.9

Note 1: Test results reported in this document relate only to the items tested

Note 2: The required tests demonstrated compliance as per client declaration of test configuration, monitoring methodology and associated pass/fail criteria

Note 3: Section 3.7 - Equipment Modifications highlights the equipment modifications that were required to bring the product into compliance with the above test matrix

This test report may be reproduced in full only. The document may only be updated by MiCOM Labs personnel. Any changes will be noted in the Document History section of the report.



Title: Silver Spring Network MicroAP
To: FCC 47 CFR Part15.247 & IC RSS-210
Serial #: SSNT62-U2 Rev A
Issue Date: 13th August 2013
Page: 21 of 147

6. TEST RESULTS

Ambient conditions for all testing performed

Temperature: 17 to 23 °C Relative humidity: 31 to 57 % Pressure: 999 to 1012 mbar

6.1. Device Characteristics

6.1.1. 20 dB and 99% Bandwidth

FCC, Part 15 Subpart C §15.247(a)(1)
Industry Canada RSS-210 §A8.1

Test Procedure

The 20 dB and 99% bandwidth is measured with a spectrum analyzer connected to the antenna terminal, while the EUT is operating in transmission mode at the appropriate center frequency and modulation.

Section 4.1 Conducted RF Emission Test Set-up identifies the test configuration

This test report may be reproduced in full only. The document may only be updated by MiCOM Labs personnel. Any changes will be noted in the Document History section of the report.



Title: Silver Spring Network MicroAP
To: FCC 47 CFR Part15.247 & IC RSS-210
Serial #: SSNT62-U2 Rev A
Issue Date: 13th August 2013
Page: 22 of 147

6.1.1.1. 900 MHz FHSS

Equipment Configuration for 20 dB & 99% Bandwidth
--

Variant:	FHSS	Duty Cycle (%):	100
Data Rate:	100 kBit/s	Antenna Gain (dBi):	Not Applicable
Modulation:	FSK	Beam Forming Gain (Y):	Not Applicable
TPC:	Not Applicable		
Engineering Test Notes:			

Test Measurement Results

Test Frequency MHz	Measured 20 dB Bandwidth (MHz)				20 dB Bandwidth (MHz)		Limit KHz	Lowest Margin kHz
	Port(s)				Highest	Lowest		
	a	b	c	d				
902.3	0.209	--	--	--	0.209	0.209	≤250.0	-41.0
915.2	0.208	--	--	--	0.208	0.208	≤250.0	-42.0
927.5	0.209	--	--	--	0.209	0.209	≤250.0	-41.0

Test Frequency MHz	Measured 99% Bandwidth (MHz)				Maximum 99% Bandwidth (MHz)		
	Port(s)						
	a	b	c	d			
902.3	0.205	--	--	--	0.205		
915.2	0.206	--	--	--	0.206		
927.5	0.207	--	--	--	0.207		

Traceability to Industry Recognized Test Methodologies	
Work Instruction:	WI-03 MEASURING RF SPECTRUM MASK
Measurement Uncertainty:	±2.81 dB

This test report may be reproduced in full only. The document may only be updated by MiCOM Labs personnel. Any changes will be noted in the Document History section of the report.



Title: Silver Spring Network MicroAP
To: FCC 47 CFR Part15.247 & IC RSS-210
Serial #: SSNT62-U2 Rev A
Issue Date: 13th August 2013
Page: 23 of 147

Equipment Configuration for 20 dB & 99% Bandwidth

Variant:	FHSS	Duty Cycle (%):	100
Data Rate:	100 kBit/s	Antenna Gain (dBi):	Not Applicable
Modulation:	GFSK	Beam Forming Gain (Y):	Not Applicable
TPC:	Not Applicable		
Engineering Test Notes:			

Test Measurement Results

Test Frequency	Measured 20 dB Bandwidth (MHz)				20 dB Bandwidth (MHz)		Limit	Lowest Margin
	Port(s)				Highest	Lowest		
MHz	a	b	c	d			KHz	kHz
902.2	0.122	--	--	--	0.122	0.122	≤250.0	-128.0
915.0	0.122	--	--	--	0.122	0.122	≤250.0	-128.0
927.8	0.123	--	--	--	0.123	0.123	≤250.0	-127.0

Test Frequency	Measured 99% Bandwidth (MHz)				Maximum 99% Bandwidth (MHz)		
	Port(s)						
MHz	a	b	c	d			
902.2	0.120	--	--	--	0.120		
915.0	0.120	--	--	--	0.120		
927.8	0.119	--	--	--	0.119		

Traceability to Industry Recognized Test Methodologies	
Work Instruction:	WI-03 MEASURING RF SPECTRUM MASK
Measurement Uncertainty:	±2.81 dB

This test report may be reproduced in full only. The document may only be updated by MiCOM Labs personnel. Any changes will be noted in the Document History section of the report.



Title: Silver Spring Network MicroAP
To: FCC 47 CFR Part15.247 & IC RSS-210
Serial #: SSNT62-U2 Rev A
Issue Date: 13th August 2013
Page: 24 of 147

Equipment Configuration for 20 dB & 99% Bandwidth

Variant:	FHSS	Duty Cycle (%):	100
Data Rate:	150 kBit/s	Antenna Gain (dBi):	Not Applicable
Modulation:	GFSK	Beam Forming Gain (Y):	Not Applicable
TPC:	Not Applicable		
Engineering Test Notes:			

Test Measurement Results

Test Frequency MHz	Measured 20 dB Bandwidth (MHz)				20 dB Bandwidth (MHz)		Limit KHz	Lowest Margin kHz
	Port(s)				Highest	Lowest		
	a	b	c	d				
902.3	0.172	--	--	--	0.172	0.172	≤250.0	-78.0
915.2	0.172	--	--	--	0.172	0.172	≤250.0	-78.0
927.5	0.171	--	--	--	0.171	0.171	≤250.0	-79.0

Test Frequency MHz	Measured 99% Bandwidth (MHz)				Maximum 99% Bandwidth (MHz)		
	Port(s)						
	a	b	c	d			
902.3	0.169	--	--	--	0.169		
915.2	0.169	--	--	--	0.169		
927.5	0.169	--	--	--	0.169		

Traceability to Industry Recognized Test Methodologies	
Work Instruction:	WI-03 MEASURING RF SPECTRUM MASK
Measurement Uncertainty:	±2.81 dB

This test report may be reproduced in full only. The document may only be updated by MiCOM Labs personnel. Any changes will be noted in the Document History section of the report.



Title: Silver Spring Network MicroAP
To: FCC 47 CFR Part15.247 & IC RSS-210
Serial #: SSNT62-U2 Rev A
Issue Date: 13th August 2013
Page: 25 of 147

Equipment Configuration for 20 dB & 99% Bandwidth

Variant:	FHSS	Duty Cycle (%):	100
Data Rate:	300 kBit/s	Antenna Gain (dBi):	Not Applicable
Modulation:	GFSK	Beam Forming Gain (Y):	Not Applicable
TPC:	Not Applicable		
Engineering Test Notes:			

Test Measurement Results

Test Frequency	Measured 20 dB Bandwidth (MHz)				20 dB Bandwidth (MHz)		Limit	Lowest Margin
	Port(s)				Highest	Lowest		
MHz	a	b	c	d			KHz	kHz
902.4	0.323	--	--	--	0.323	0.323	≥250.0	-73.0
915.2	0.325	--	--	--	0.325	0.325	≥250.0	-75.0
927.6	0.325	--	--	--	0.325	0.325	≥250.0	-75.0

Test Frequency	Measured 99% Bandwidth (MHz)				Maximum 99% Bandwidth (MHz)		
	Port(s)						
MHz	a	b	c	d			
902.4	0.317	--	--	--	0.317		
915.2	0.319	--	--	--	0.319		
927.6	0.319	--	--	--	0.319		

Traceability to Industry Recognized Test Methodologies

Work Instruction:	WI-03 MEASURING RF SPECTRUM MASK
Measurement Uncertainty:	±2.81 dB

This test report may be reproduced in full only. The document may only be updated by MiCOM Labs personnel. Any changes will be noted in the Document History section of the report.



Title: Silver Spring Network MicroAP
To: FCC 47 CFR Part15.247 & IC RSS-210
Serial #: SSNT62-U2 Rev A
Issue Date: 13th August 2013
Page: 26 of 147

6.1.1.2. 2.4 GHz FHSS

Equipment Configuration for 20 dB & 99% Bandwidth

Variant:	FHSS	Duty Cycle (%):	100
Data Rate:	250 kBit/s	Antenna Gain (dBi):	Not Applicable
Modulation:	GFSK	Beam Forming Gain (Y):	Not Applicable
TPC:	Not Applicable		
Engineering Test Notes:	External Antenna Port		

Test Measurement Results

Test Frequency MHz	Measured 6 dB Bandwidth (MHz) Port(s)				6 dB Bandwidth (MHz)		Limit KHz	Lowest Margin MHz
	a	b	c	d	Highest	Lowest		
2400.8	0.283	--	--	--	0.283	0.283		
2440.0	0.283	--	--	--	0.283	0.283		
2472.8	0.283	--	--	--	0.283	0.283		

Test Frequency MHz	Measured 99% Bandwidth (MHz) Port(s)				Maximum 99% Bandwidth (MHz)		
	a	b	c	d			
2400.8	0.271	--	--	--	0.271		
2440.0	0.271	--	--	--	0.271		
2472.8	0.271	--	--	--	0.271		

Traceability to Industry Recognized Test Methodologies	
Work Instruction:	WI-03 MEASURING RF SPECTRUM MASK
Measurement Uncertainty:	±2.81 dB

This test report may be reproduced in full only. The document may only be updated by MiCOM Labs personnel. Any changes will be noted in the Document History section of the report.



Title: Silver Spring Network MicroAP
To: FCC 47 CFR Part15.247 & IC RSS-210
Serial #: SSNT62-U2 Rev A
Issue Date: 13th August 2013
Page: 27 of 147

Equipment Configuration for 20 dB & 99% Bandwidth

Variant:	FHSS	Duty Cycle (%):	100
Data Rate:	500 kBit/s	Antenna Gain (dBi):	Not Applicable
Modulation:	GFSK	Beam Forming Gain (Y):	Not Applicable
TPC:	Not Applicable		
Engineering Test Notes:	External Antenna Port		

Test Measurement Results

Test Frequency MHz	Measured 6 dB Bandwidth (MHz) Port(s)				6 dB Bandwidth (MHz)		Limit KHz	Lowest Margin MHz
	a	b	c	d	Highest	Lowest		
2400.8	0.529	--	--	--	0.529	0.529		
2440.0	0.529	--	--	--	0.529	0.529		
2472.8	0.529	--	--	--	0.529	0.529		

Test Frequency MHz	Measured 99% Bandwidth (MHz) Port(s)				Maximum 99% Bandwidth (MHz)		
	a	b	c	d			
2400.8	0.517	--	--	--	0.517		
2440.0	0.517	--	--	--	0.517		
2472.8	0.517	--	--	--	0.517		

Traceability to Industry Recognized Test Methodologies	
Work Instruction:	WI-03 MEASURING RF SPECTRUM MASK
Measurement Uncertainty:	±2.81 dB

This test report may be reproduced in full only. The document may only be updated by MiCOM Labs personnel. Any changes will be noted in the Document History section of the report.



Title: Silver Spring Network MicroAP
To: FCC 47 CFR Part15.247 & IC RSS-210
Serial #: SSNT62-U2 Rev A
Issue Date: 13th August 2013
Page: 28 of 147

Specification

Limits

FCC §15.247 (a)(1)
Industry Canada RSS-210 §8.1(c)

For frequency hopping systems operating in the 902-928 MHz band: if the 20 dB bandwidth of the hopping channel is less than 250 kHz, the system shall use at least 50 hopping frequencies and the average time of occupancy on any frequency shall not be greater than 0.4 seconds within a 20 second period; if the 20 dB bandwidth of the hopping channel is 250 kHz or greater, the system shall use at least 25 hopping frequencies and the average time of occupancy on any frequency shall not be greater than 0.4 seconds within a 10 second period. The maximum allowed 20 dB bandwidth of the hopping channel is 500 kHz.

Laboratory Measurement Uncertainty for Spectrum Measurement

Measurement uncertainty	±2.81 dB
-------------------------	----------

Traceability

Method	Test Equipment Used
Measurements were made per work instruction WI-03 'Measurement of RF Spectrum Mask'	0158, 0193, 0252, 0313, 0314, 0070, 0116, 0117

This test report may be reproduced in full only. The document may only be updated by MiCOM Labs personnel. Any changes will be noted in the Document History section of the report.



6.1.2. FHSS Transmitter Characteristics

FCC, Part 15 Subpart C §15.247(a)(1)
Industry Canada RSS-210 §A8.1

Test Procedure

The number of channels and channel occupancy is measured with a spectrum analyzer connected to the antenna terminal, while the EUT is operating in transmission mode at the appropriate center frequency and modulation.

Section 4.1 Conducted RF Emission Test Set-up identifies the test configuration

6.1.2.1. FSK 900 MHz 100 kBit/s

1. Number of Hopping Channels

Frequency Range MHz	No. of Hopping Channels	Total Hopping Channels
902 - 915	43	83
915 - 928	40	



NUMBER OF FREQUENCY HOPPING CHANNELS 902-915 MHz

Marker 1 [T1] RBW 100 kHz RF Att 30 dB
Ref Lvl 30.29 dBm VBW 100 kHz
35 dBm 905.93386774 MHz SWT 5 ms Unit dBm

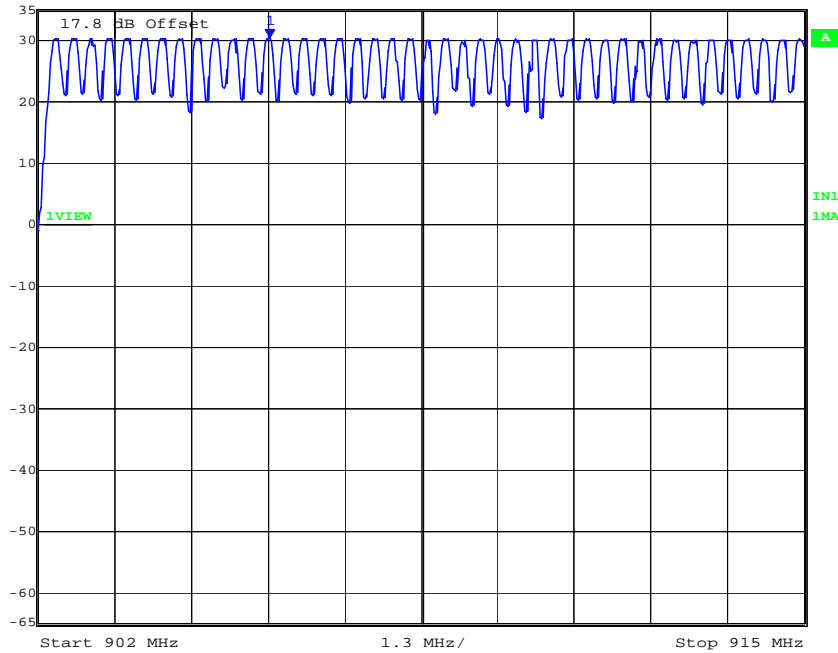

Date: 8.JUL.2013 10:55:21

NUMBER OF FREQUENCY HOPPING CHANNELS 915-928 MHz

Marker 1 [T1] RBW 100 kHz RF Att 30 dB
Ref Lvl 30.07 dBm VBW 100 kHz
35 dBm 916.09418838 MHz SWT 5 ms Unit dBm

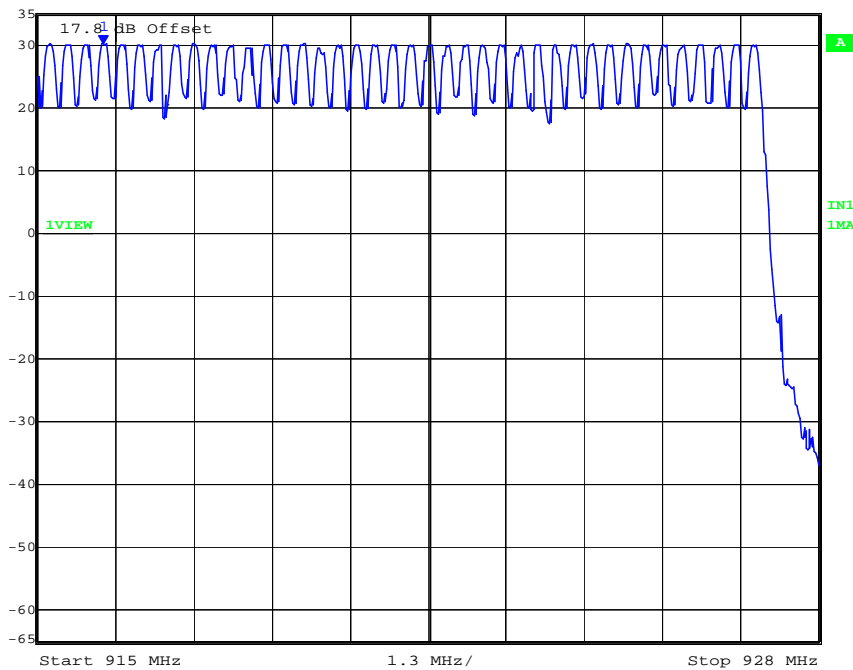

Date: 8.JUL.2013 10:57:36

This test report may be reproduced in full only. The document may only be updated by MiCOM Labs personnel. Any changes will be noted in the Document History section of the report.



2. Channel Spacing

Channel Spacing (KHz)	Maximum 20 dB Bandwidth (kHz)	Specification	Compliant
324.65	209.0	Greater than maximum 20 dB Bandwidth	√

Channel Spacing

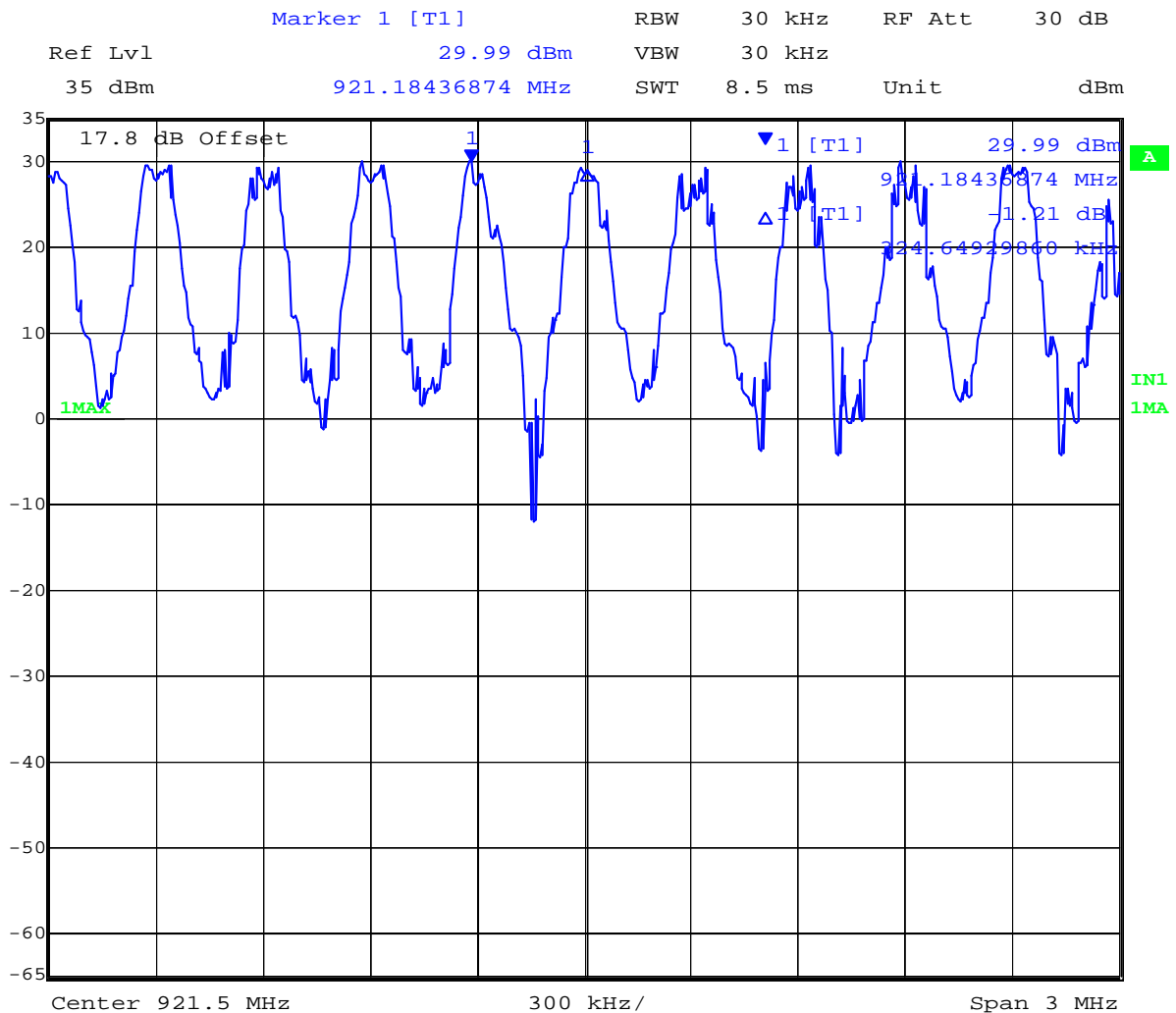

Date: 8 JUL 2013 11:09:33

This test report may be reproduced in full only. The document may only be updated by MiCOM Labs personnel. Any changes will be noted in the Document History section of the report.



3. Dwell Time

Channel (MHz)	Dwell Time mS
902.3	7.536

Dwell Time

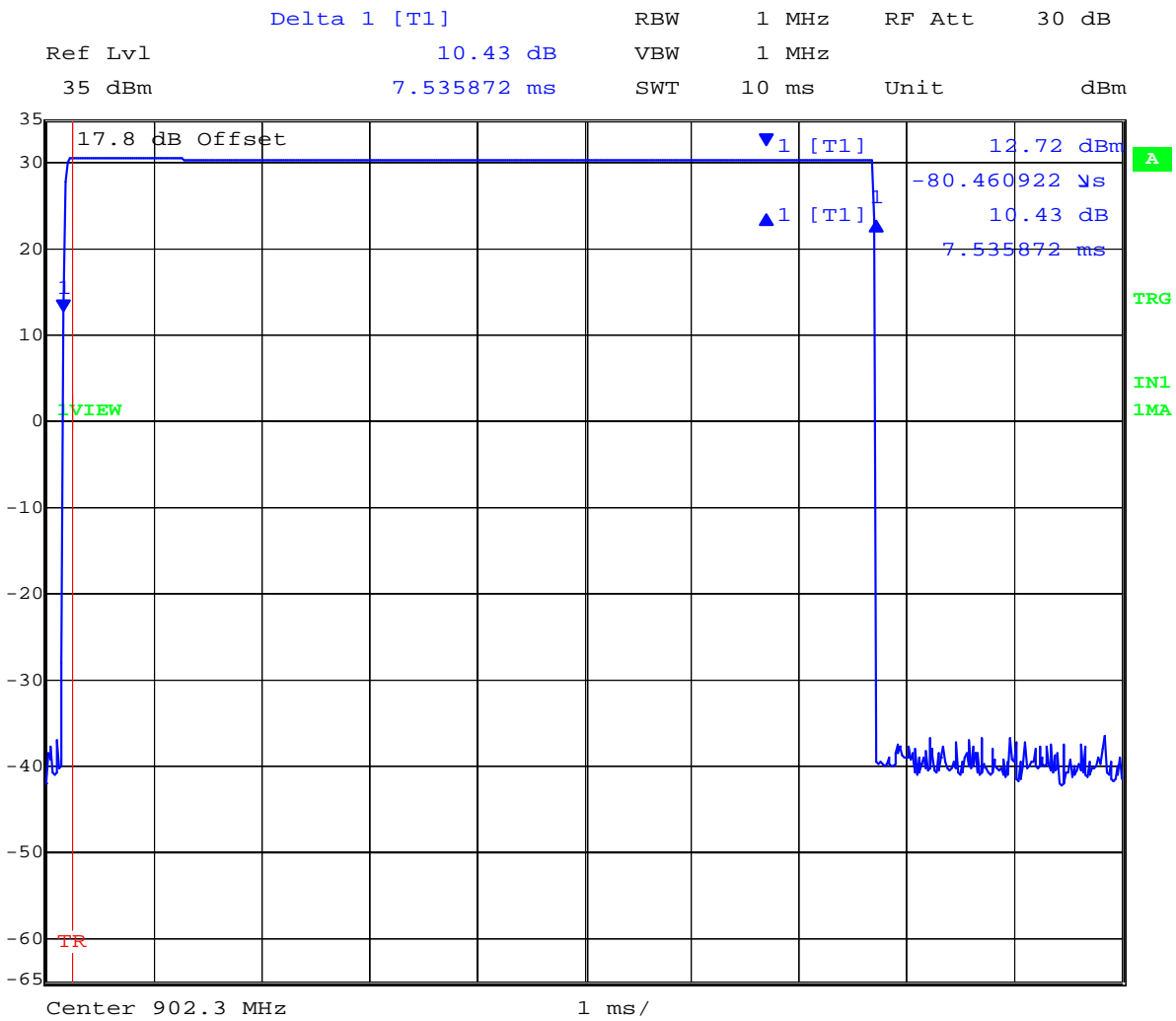

Date: 8.JUL.2013 11:20:32

This test report may be reproduced in full only. The document may only be updated by MiCOM Labs personnel. Any changes will be noted in the Document History section of the report.



4. Channel Occupancy

Channel (MHz)	# of Hops in 20 Secs	Dwell Time mS	Channel Occupancy mS	Compliant
902.3	8	7.536	60.29	√

Channel Occupancy

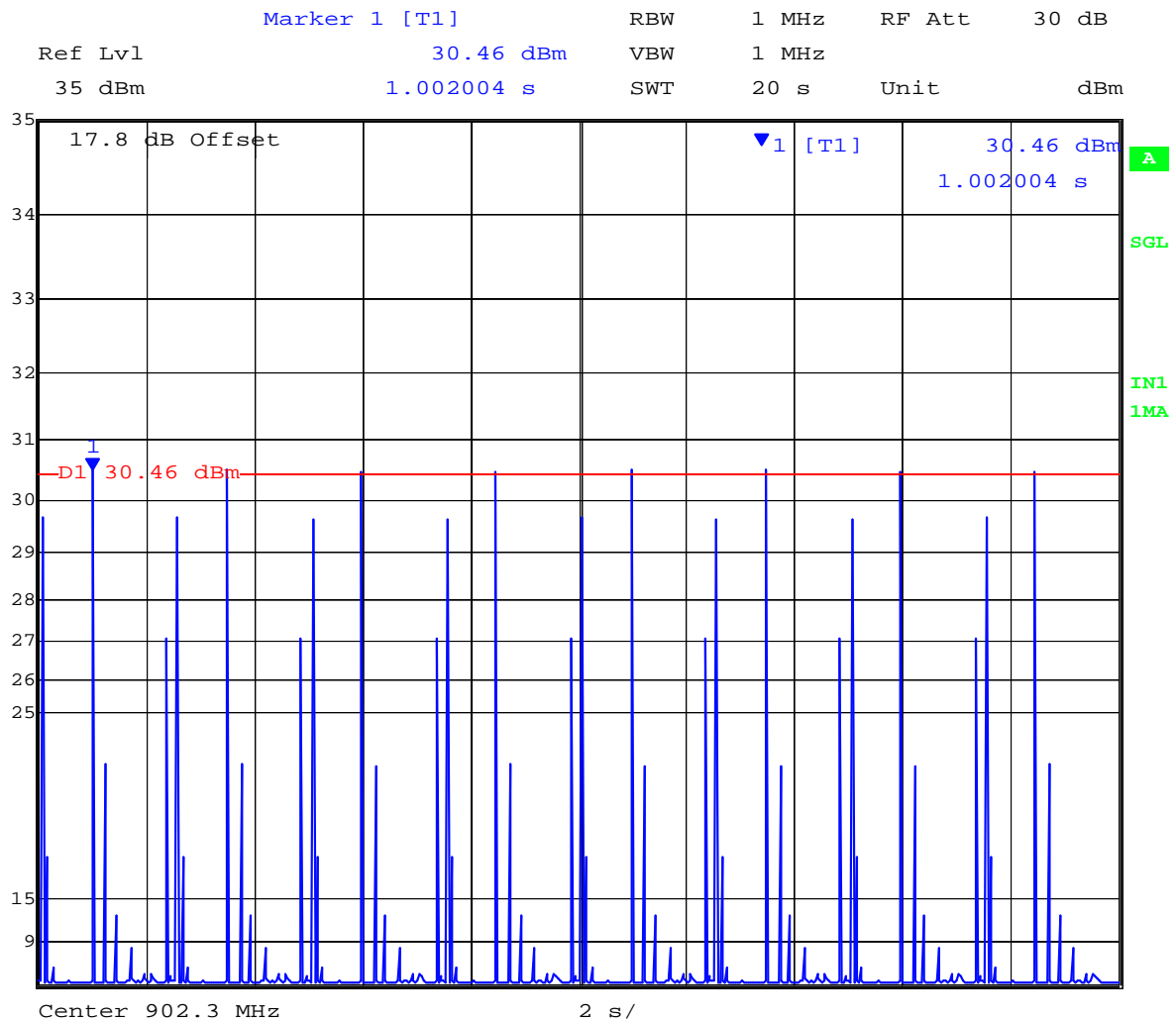

Date: 8.JUL.2013 11:29:20

This test report may be reproduced in full only. The document may only be updated by MiCOM Labs personnel. Any changes will be noted in the Document History section of the report.



6.1.2.2. GFSK 900 MHz 100 kBit/s

1. Number of Hopping Channels

Frequency Range MHz	No. of Hopping Channels	Total Hopping Channels
902 - 912	48	128
912 - 920	41	
920 - 928	39	

NUMBER OF FREQUENCY HOPPING CHANNELS 902-912 MHz



This test report may be reproduced in full only. The document may only be updated by MiCOM Labs personnel. Any changes will be noted in the Document History section of the report.



NUMBER OF FREQUENCY HOPPING CHANNELS 912-920 MHz

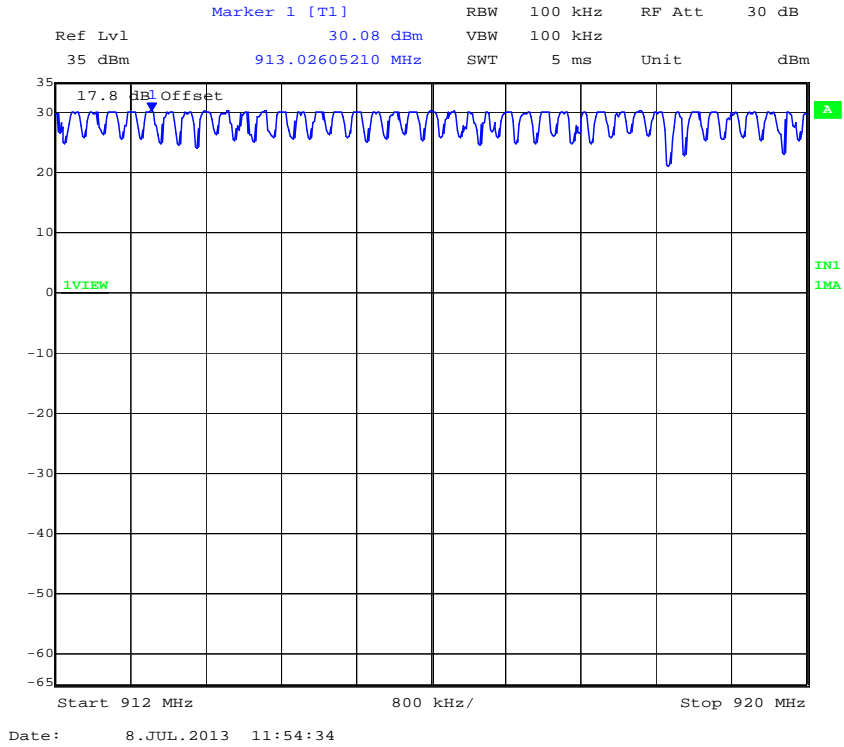

NUMBER OF FREQUENCY HOPPING CHANNELS 920-928 MHz

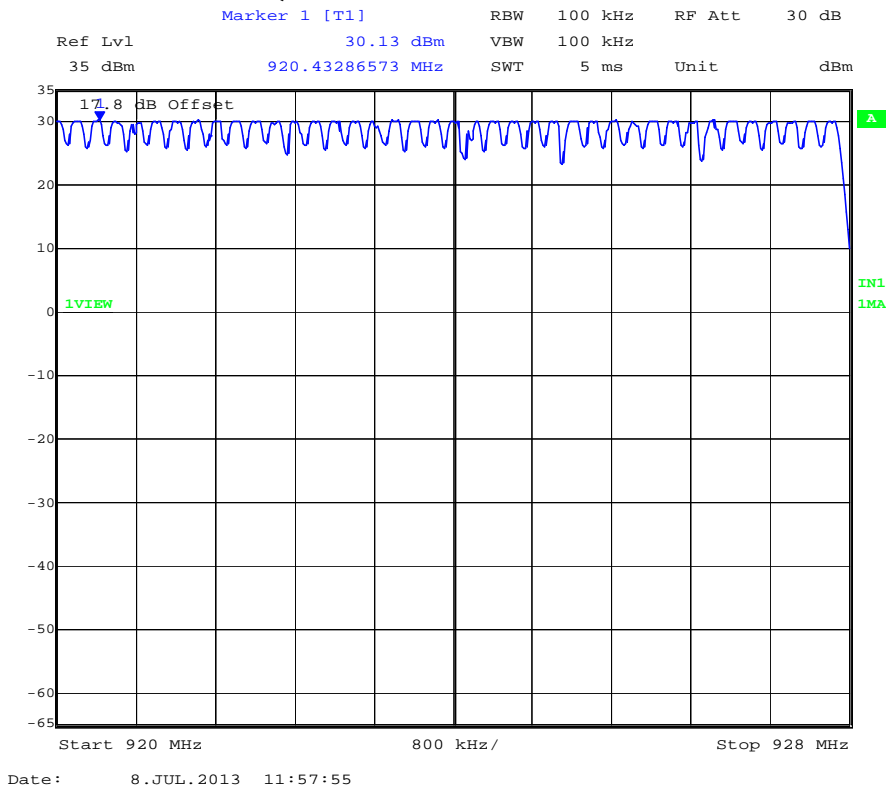

This test report may be reproduced in full only. The document may only be updated by MiCOM Labs personnel. Any changes will be noted in the Document History section of the report.



2. Channel Spacing

Channel Spacing (KHz)	Maximum 20 dB Bandwidth (kHz)	Specification	Compliant
200.00	123.0	Greater than maximum 20 dB Bandwidth	√

Channel Spacing

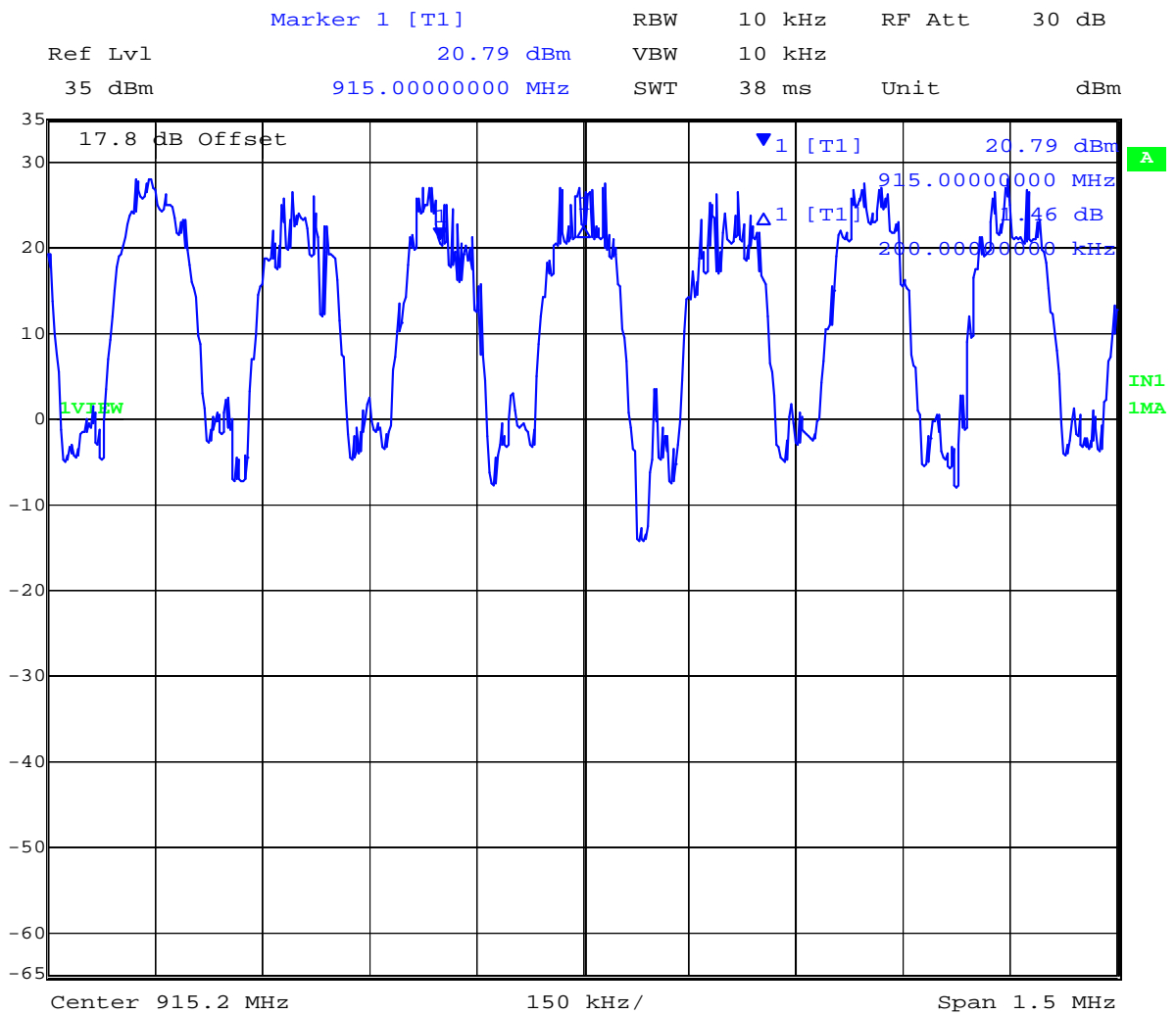

Date: 8.JUL.2013 11:48:30

This test report may be reproduced in full only. The document may only be updated by MiCOM Labs personnel. Any changes will be noted in the Document History section of the report.



3. Dwell Time

Channel (MHz)	Dwell Time mS
902.4	7.595

Dwell Time

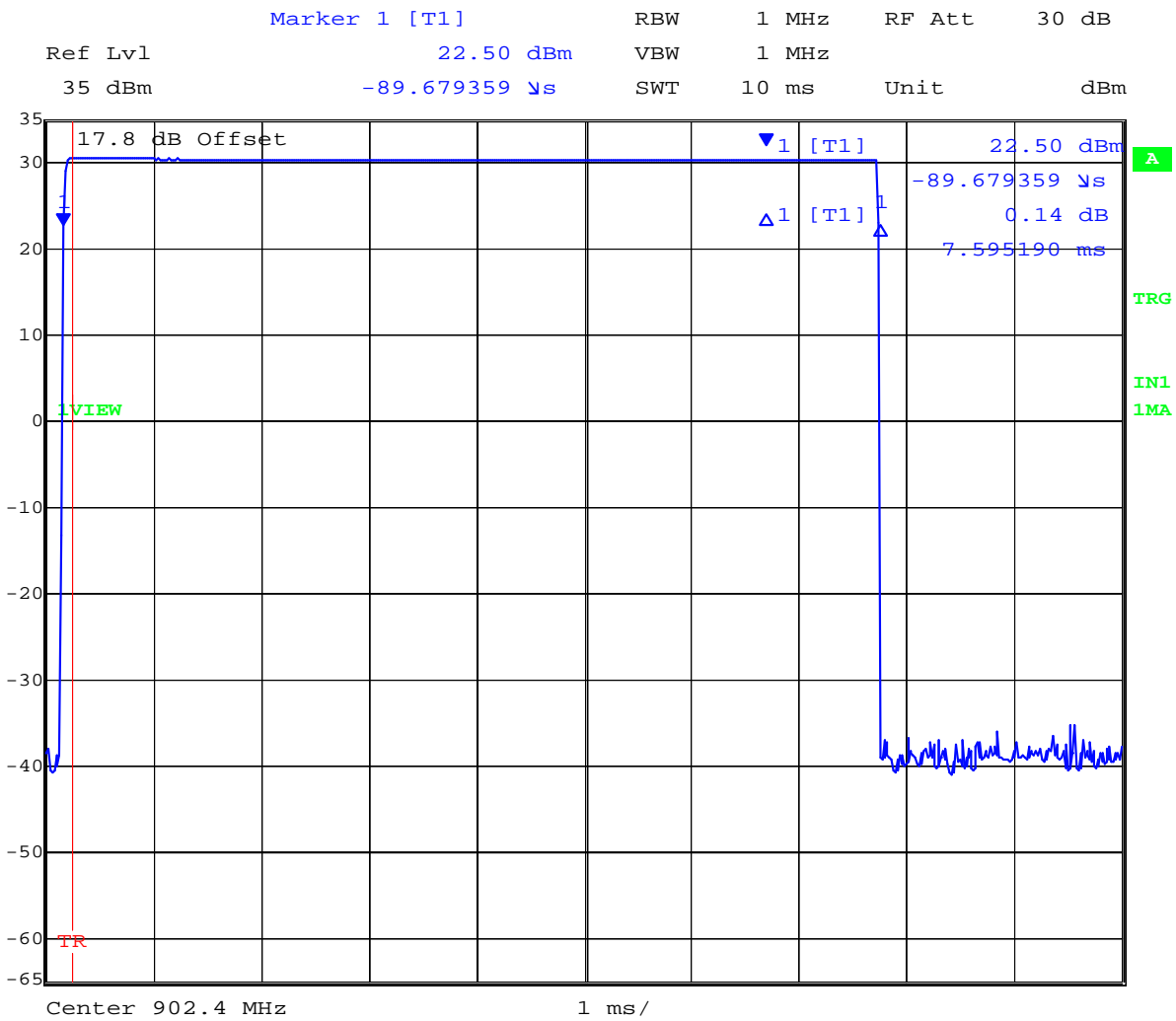

Date: 8.JUL.2013 11:39:21

This test report may be reproduced in full only. The document may only be updated by MiCOM Labs personnel. Any changes will be noted in the Document History section of the report.



4. Channel Occupancy

Channel (MHz)	# of Hops in 20 Secs	Dwell Time mS	Channel Occupancy mS	Compliant
902.4	5	7.595	37.975	√

Channel Occupancy

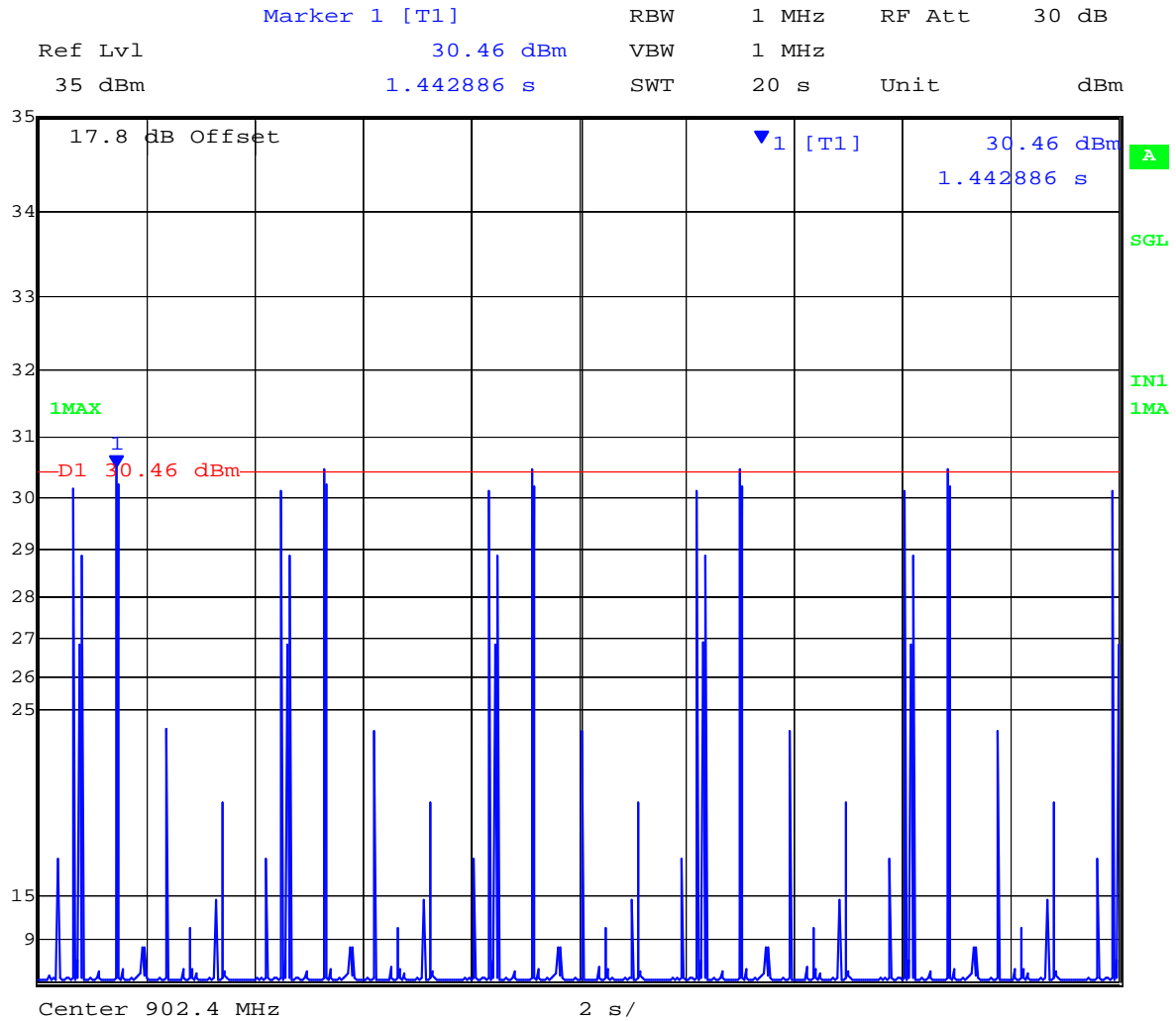

Date: 8.JUL.2013 11:34:08

This test report may be reproduced in full only. The document may only be updated by MiCOM Labs personnel. Any changes will be noted in the Document History section of the report.



Title: Silver Spring Network MicroAP
To: FCC 47 CFR Part15.247 & IC RSS-210
Serial #: SSNT62-U2 Rev A
Issue Date: 13th August 2013
Page: 39 of 147

6.1.2.3. GFSK 900 MHz 300 kBit/s

1. Number of Hopping Channels

Frequency Range MHz	No. of Hopping Channels	Total Hopping Channels
902 - 915	32	64
915 - 928	32	

This test report may be reproduced in full only. The document may only be updated by MiCOM Labs personnel. Any changes will be noted in the Document History section of the report.



Title: Silver Spring Network MicroAP
To: FCC 47 CFR Part15.247 & IC RSS-210
Serial #: SSNT62-U2 Rev A
Issue Date: 13th August 2013
Page: 40 of 147

NUMBER OF FREQUENCY HOPPING CHANNELS 902-915 MHz

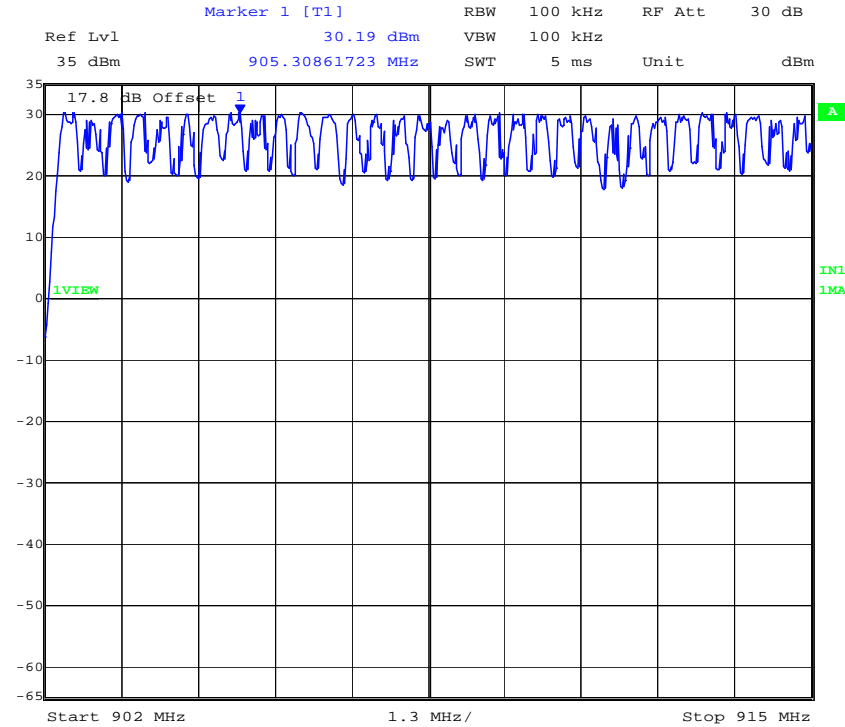

Date: 8.JUL.2013 12:06:01

NUMBER OF FREQUENCY HOPPING CHANNELS 915-928 MHz

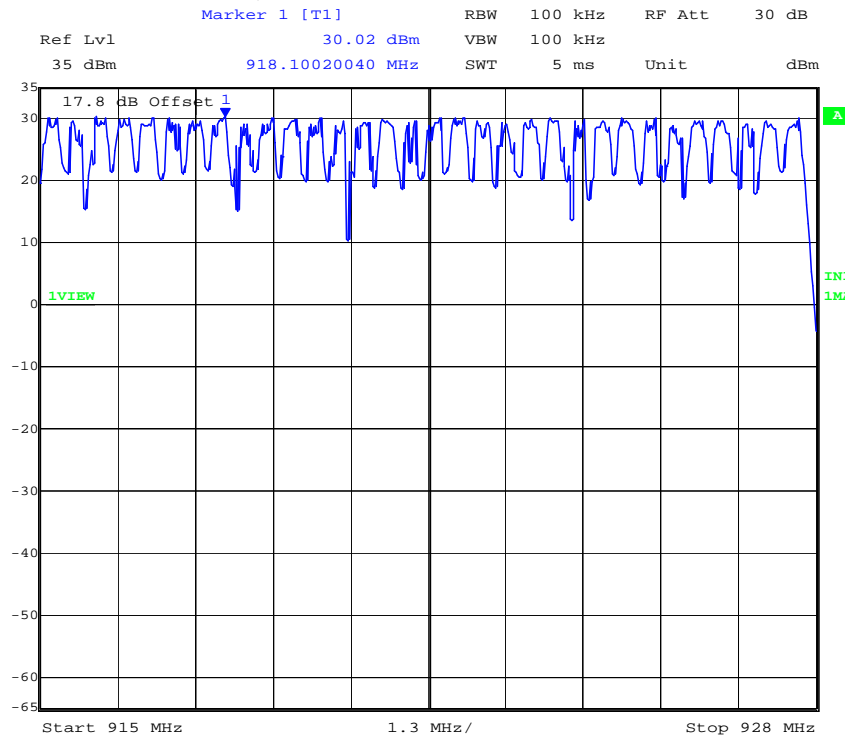

Date: 8.JUL.2013 12:08:17

This test report may be reproduced in full only. The document may only be updated by MiCOM Labs personnel. Any changes will be noted in the Document History section of the report.



2. Channel Spacing

Channel Spacing (KHz)	Maximum 20 dB Bandwidth (kHz)	Specification	Compliant
409.0	325.0	Greater than maximum 20 dB Bandwidth	√

Channel Spacing

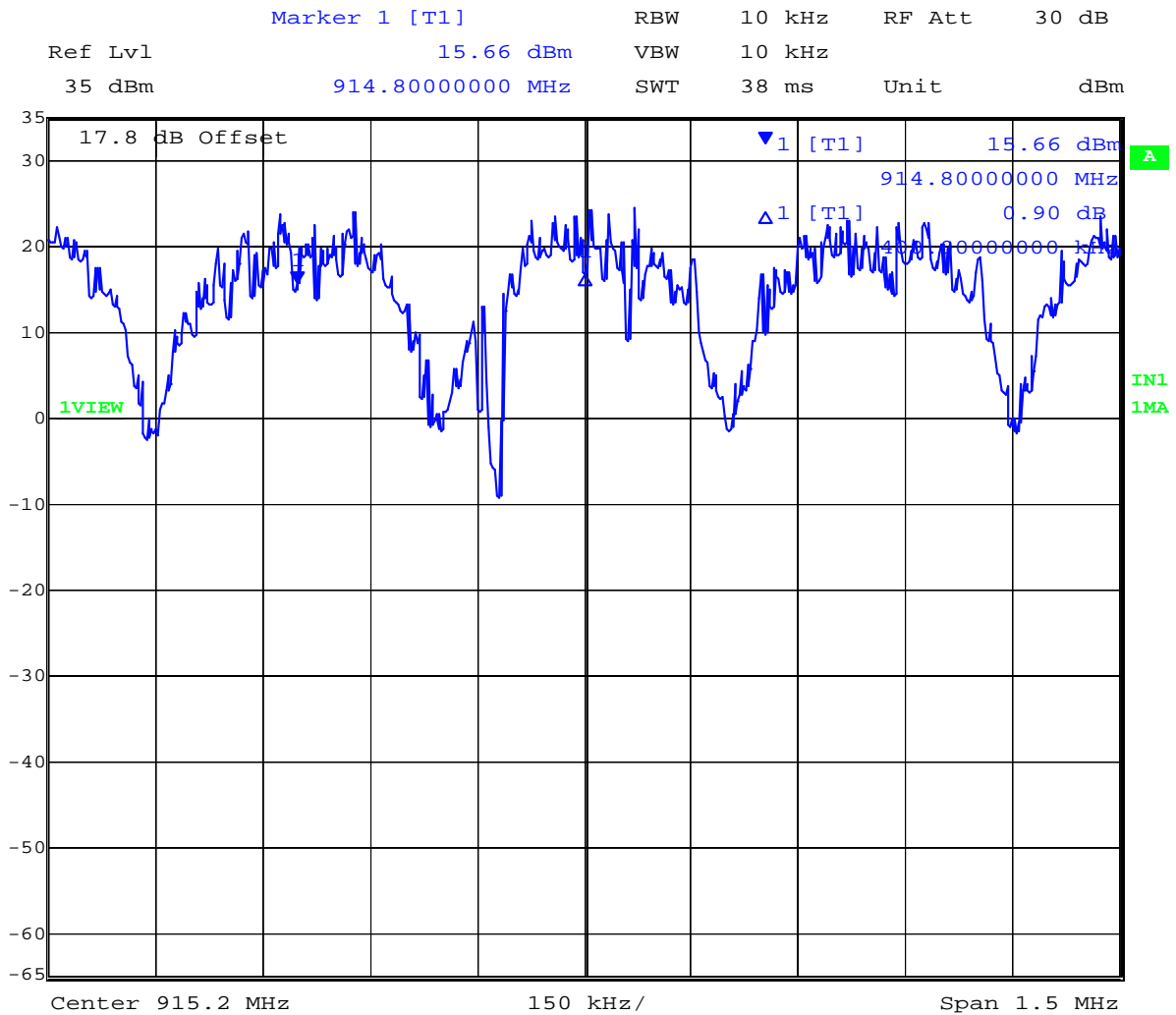

Date: 8.JUL.2013 12:19:43

This test report may be reproduced in full only. The document may only be updated by MiCOM Labs personnel. Any changes will be noted in the Document History section of the report.



3. Dwell Time

Channel (MHz)	Dwell Time mS
915.2	3.106

Dwell Time

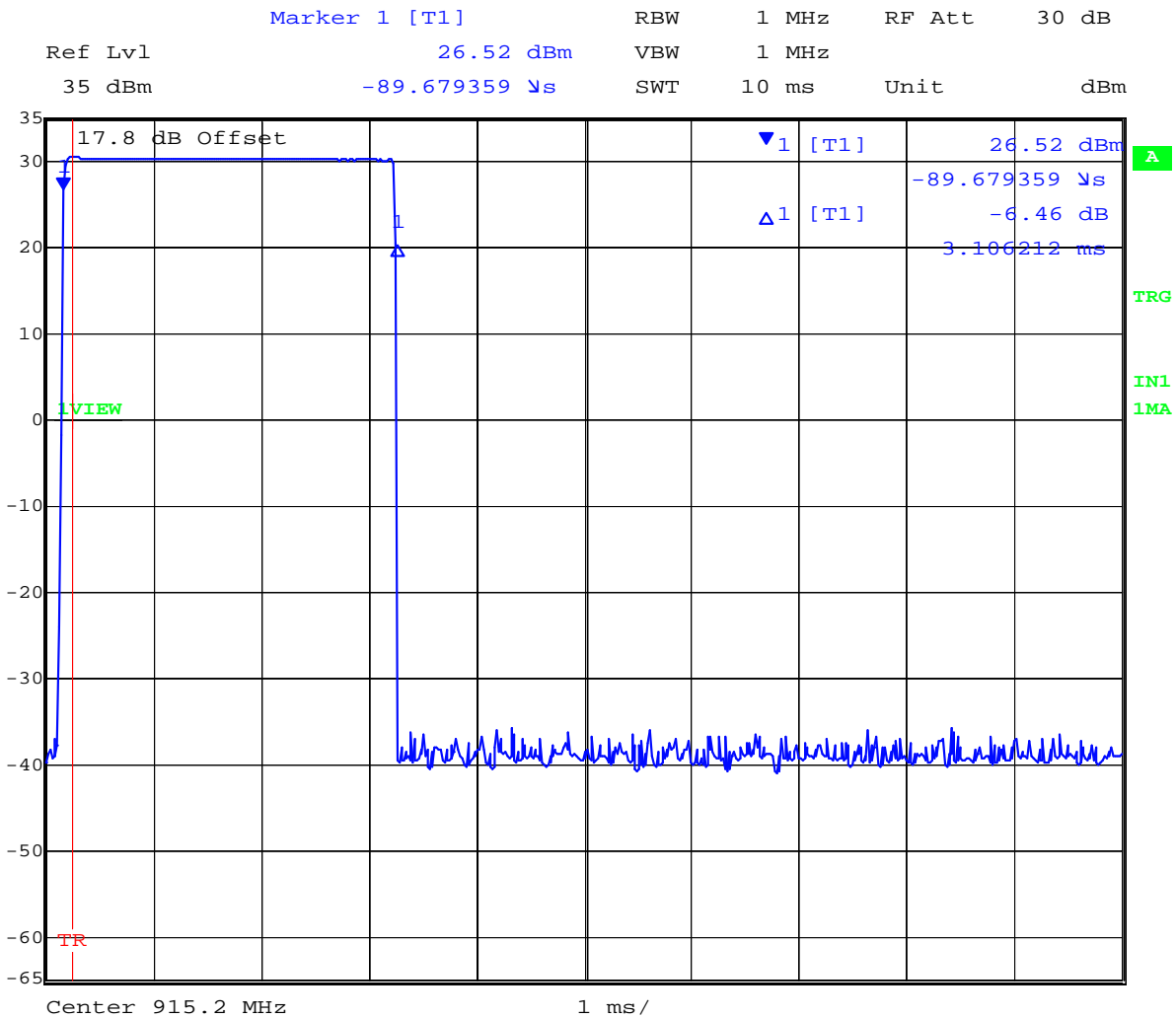

Date: 8.JUL.2013 12:23:50

This test report may be reproduced in full only. The document may only be updated by MiCOM Labs personnel. Any changes will be noted in the Document History section of the report.



4. Channel Occupancy

Channel (MHz)	# of Hops in 10 Secs	Dwell Time mS	Channel Occupancy mS	Compliant
915.2	8	3.106	24.848	√

Channel Occupancy

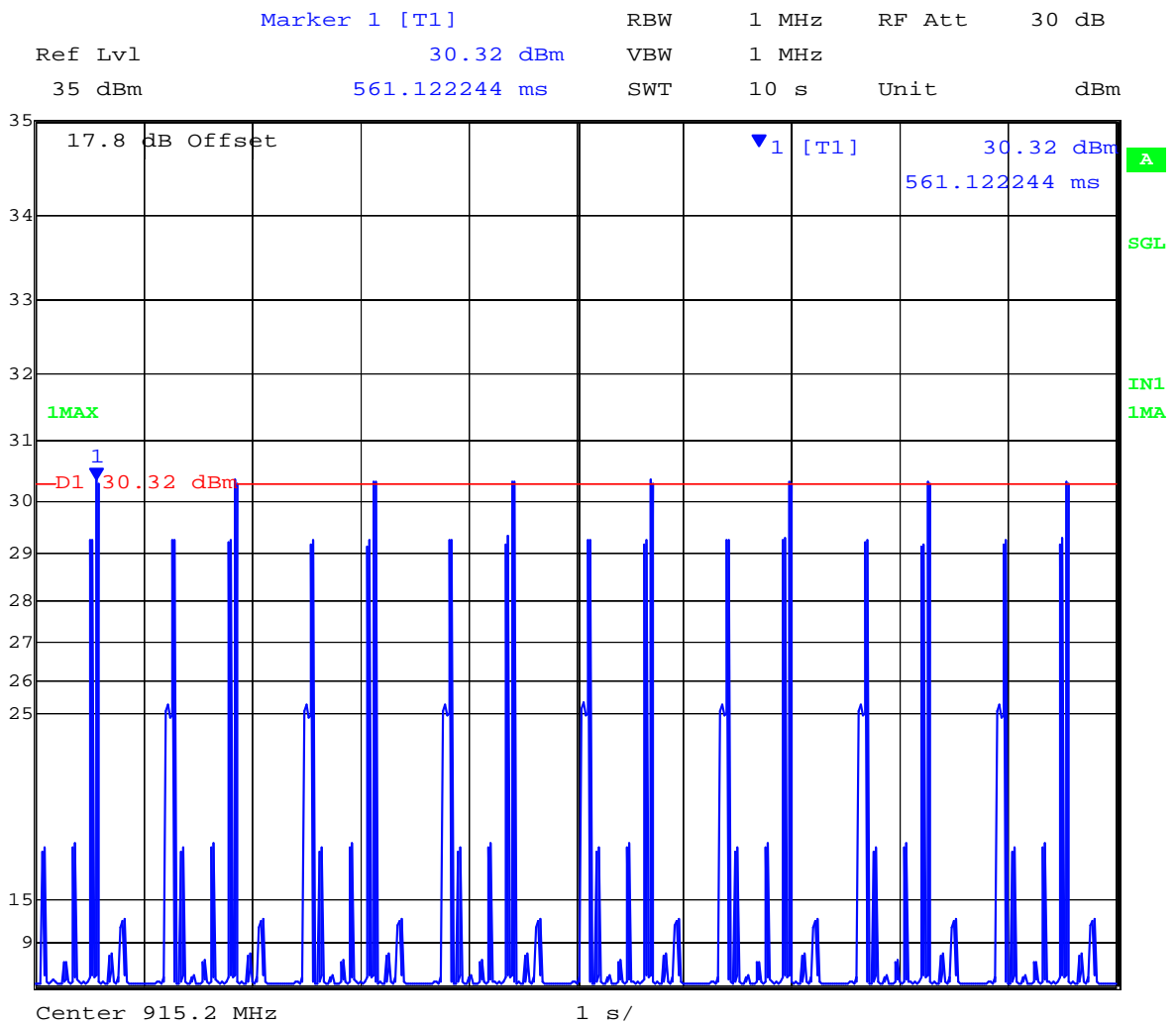

Date: 8.JUL.2013 12:26:59

This test report may be reproduced in full only. The document may only be updated by MiCOM Labs personnel. Any changes will be noted in the Document History section of the report.



6.1.2.4. GFSK 2.4 GHz 250 kBit/s

1. Number of Hopping Channels

Frequency Range MHz	No. of Hopping Channels	Total Hopping Channels
2400-2442	52	91
2442-2483.5	39	



NUMBER OF FREQUENCY HOPPING CHANNELS 2400-2442 MHz

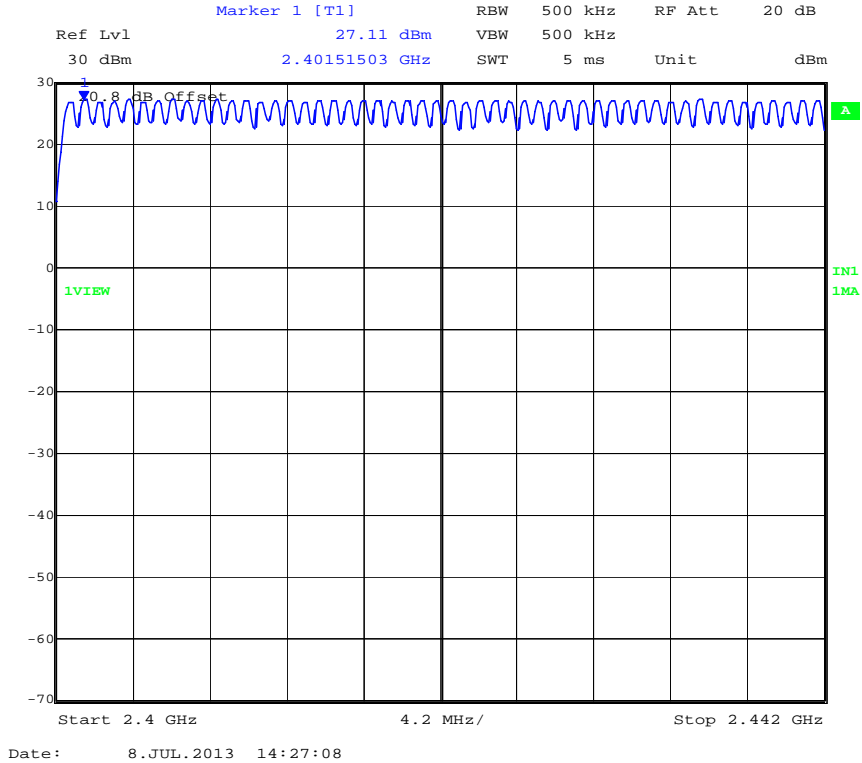

NUMBER OF FREQUENCY HOPPING CHANNELS 2442-2483.5 MHz

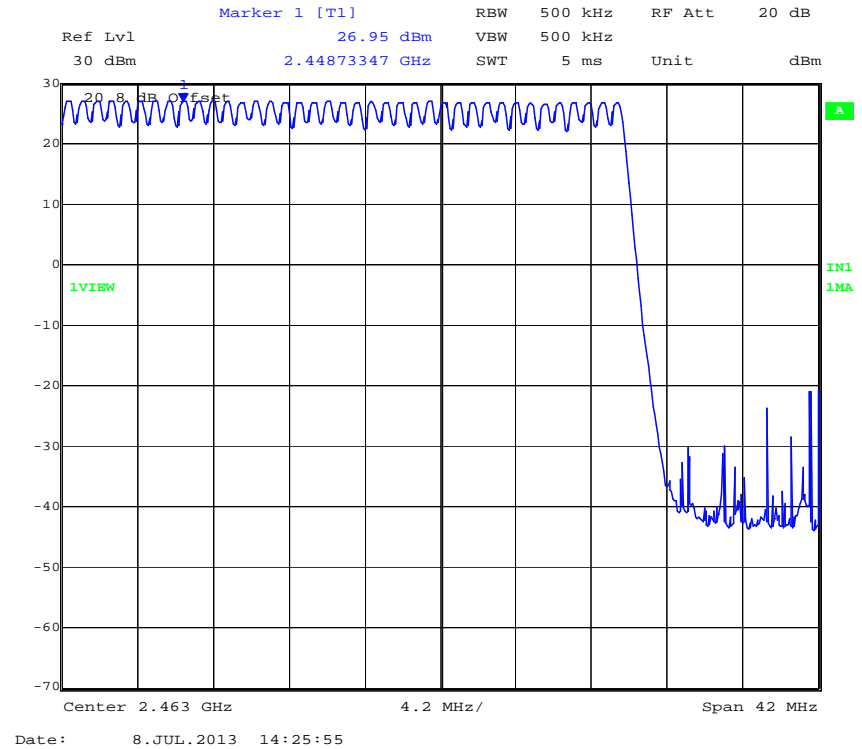

This test report may be reproduced in full only. The document may only be updated by MiCOM Labs personnel. Any changes will be noted in the Document History section of the report.



2. Channel Spacing

Channel Spacing (KHz)	Maximum 20 dB Bandwidth (kHz)	Specification	Compliant
800.0	283.0	Greater than maximum 20 dB Bandwidth	√

Channel Spacing

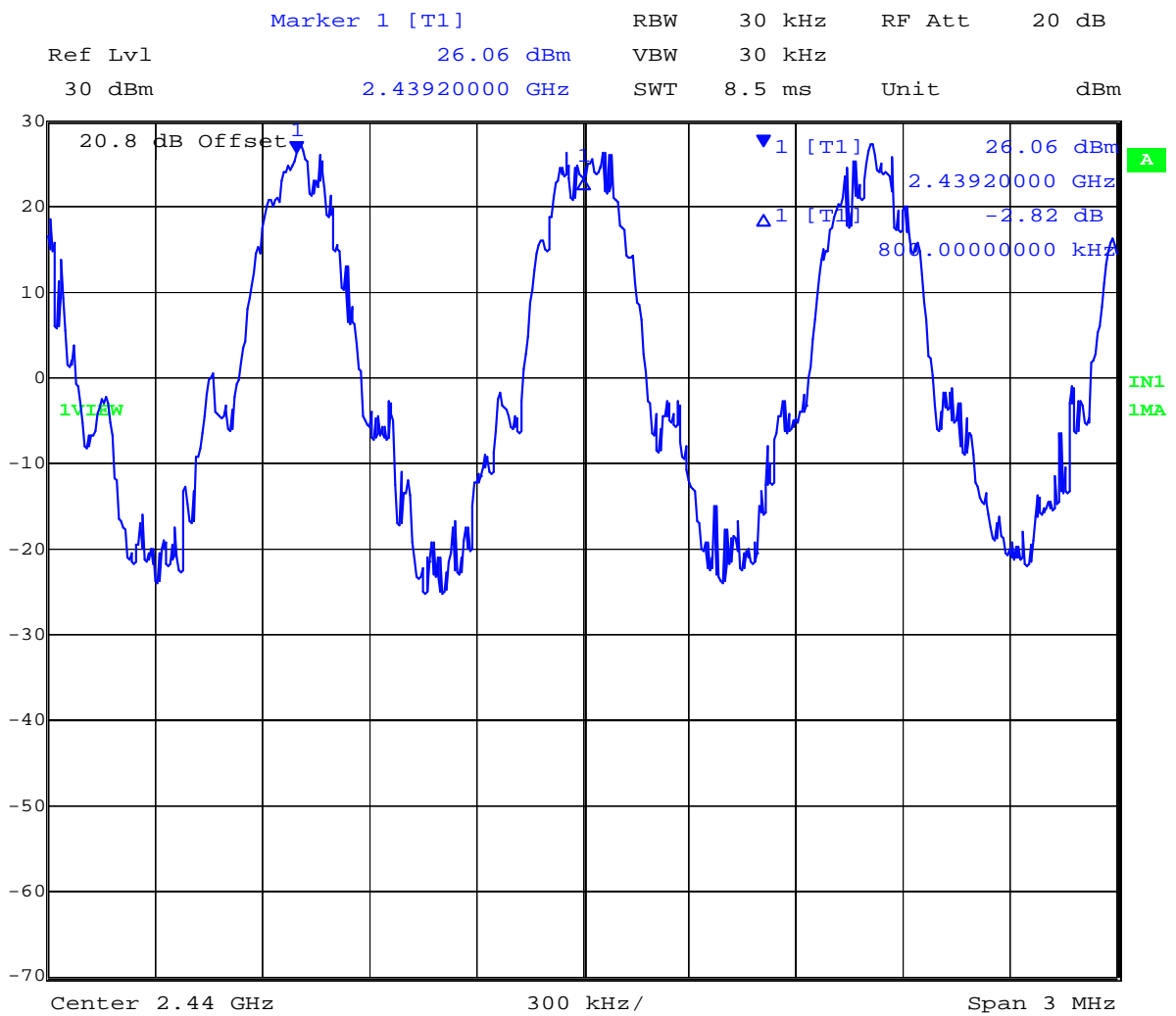

Date: 8.JUL.2013 14:33:08

This test report may be reproduced in full only. The document may only be updated by MiCOM Labs personnel. Any changes will be noted in the Document History section of the report.



3. Dwell Time

Channel (MHz)	Dwell Time mS
2400.8	3.242

Dwell Time

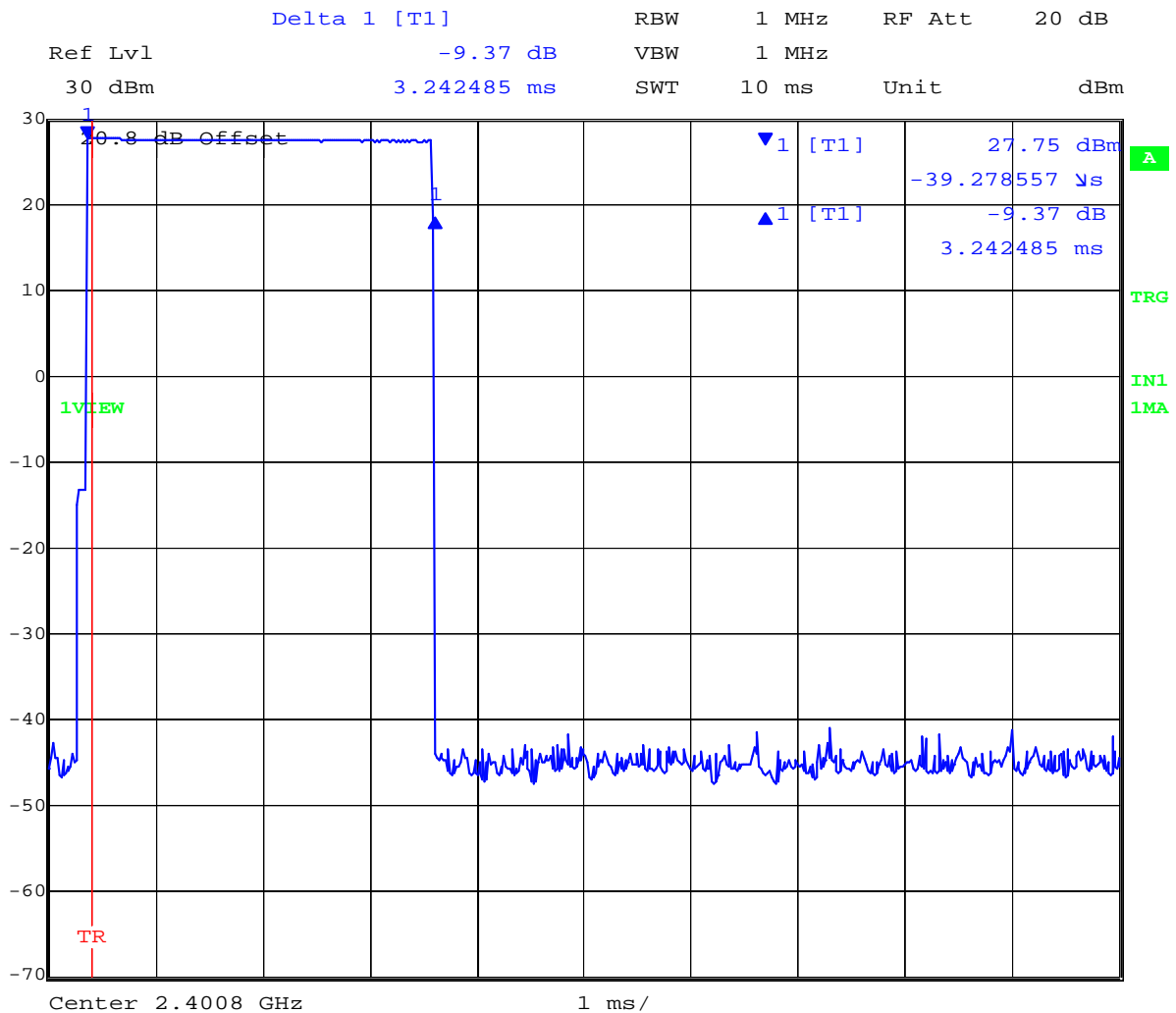

Date: 8.JUL.2013 14:36:38

This test report may be reproduced in full only. The document may only be updated by MiCOM Labs personnel. Any changes will be noted in the Document History section of the report.



4. Channel Occupancy

Channel (MHz)	# of Hops in 10 Secs	Dwell Time mS	Channel Occupancy mS	Compliant
2400.8	6	3.242	19.452	√

Channel Occupancy

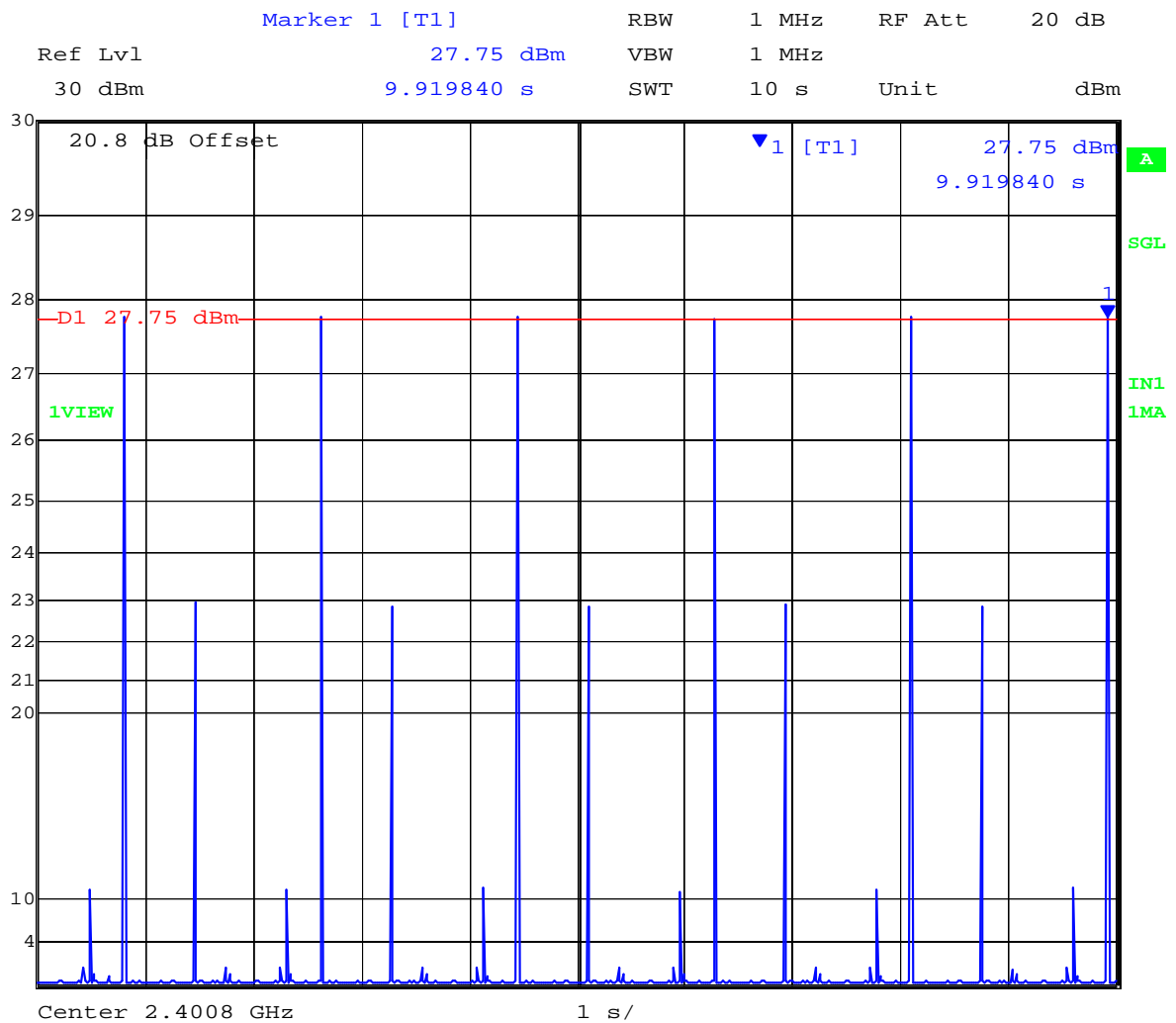

Date: 8.JUL.2013 14:38:15

This test report may be reproduced in full only. The document may only be updated by MiCOM Labs personnel. Any changes will be noted in the Document History section of the report.



Title: Silver Spring Network MicroAP
To: FCC 47 CFR Part15.247 & IC RSS-210
Serial #: SSNT62-U2 Rev A
Issue Date: 13th August 2013
Page: 49 of 147

6.1.2.5. GFSK 2.4 GHz 500 kBit/s

1. Number of Hopping Channels

Frequency Range MHz	No. of Hopping Channels	Total Hopping Channels
2400-2442	52	91
2442-2483.5	39	

This test report may be reproduced in full only. The document may only be updated by MiCOM Labs personnel. Any changes will be noted in the Document History section of the report.



NUMBER OF FREQUENCY HOPPING CHANNELS 2400-2442 MHz

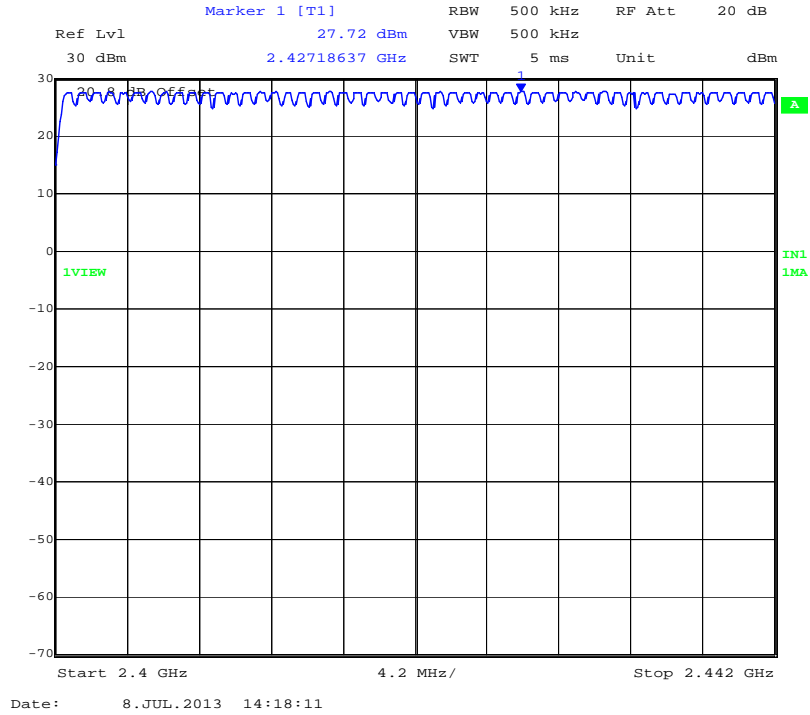

NUMBER OF FREQUENCY HOPPING CHANNELS 2442-2483.5 MHz

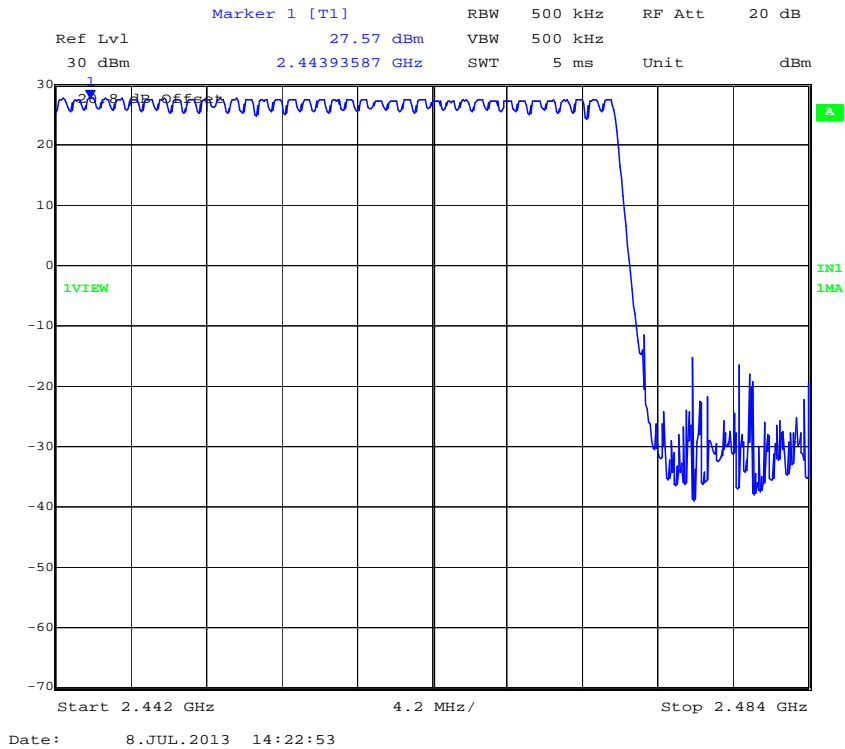

This test report may be reproduced in full only. The document may only be updated by MiCOM Labs personnel. Any changes will be noted in the Document History section of the report.



2. Channel Spacing

Channel Spacing (KHz)	Maximum 20 dB Bandwidth (kHz)	Specification	Compliant
800.0	529.0	Greater than maximum 20 dB Bandwidth	√

Channel Spacing

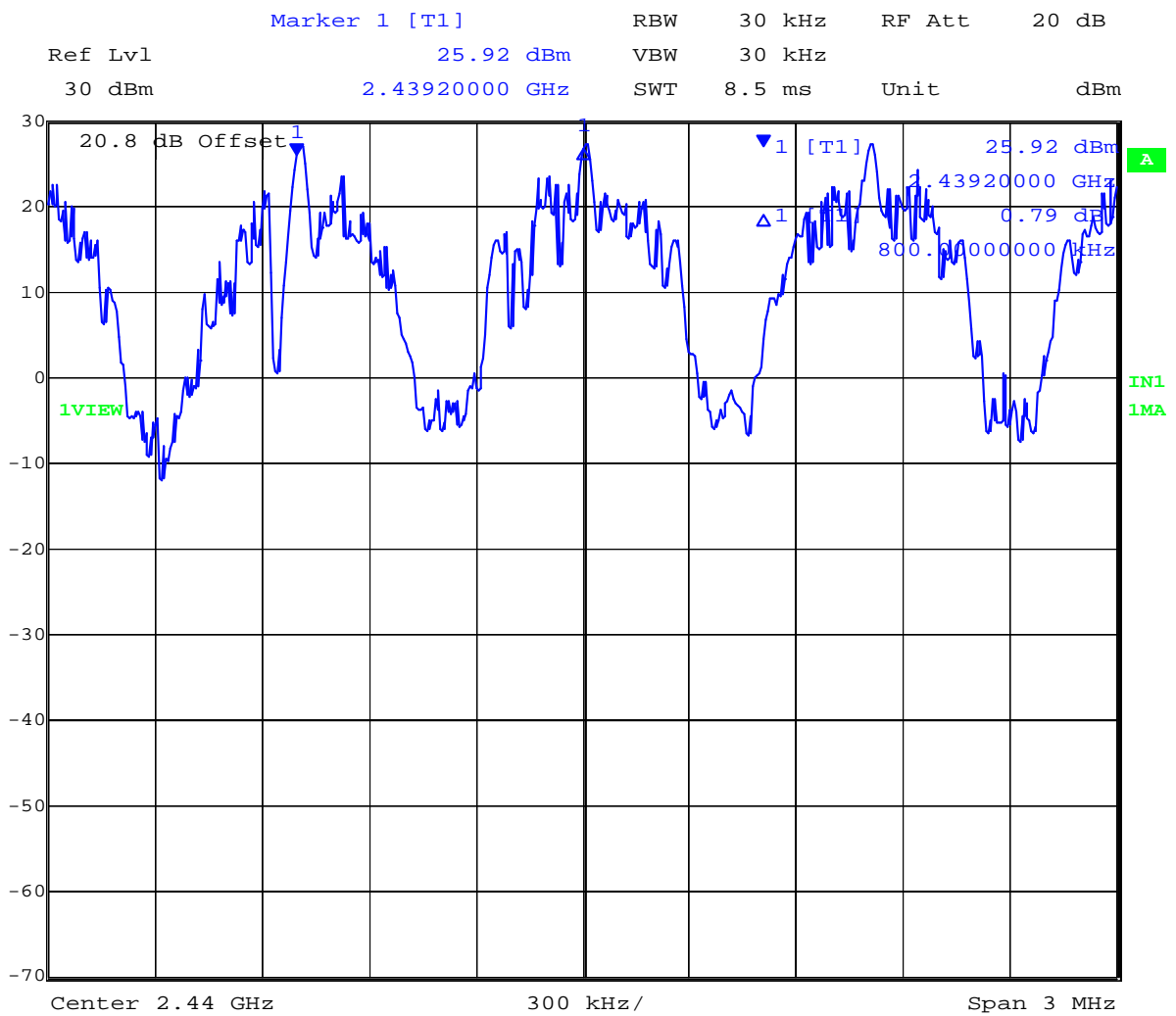

Date: 8.JUL.2013 14:04:40

This test report may be reproduced in full only. The document may only be updated by MiCOM Labs personnel. Any changes will be noted in the Document History section of the report.



3. Dwell Time

Channel (MHz)	Dwell Time mS
2400.8	1.844

Dwell Time

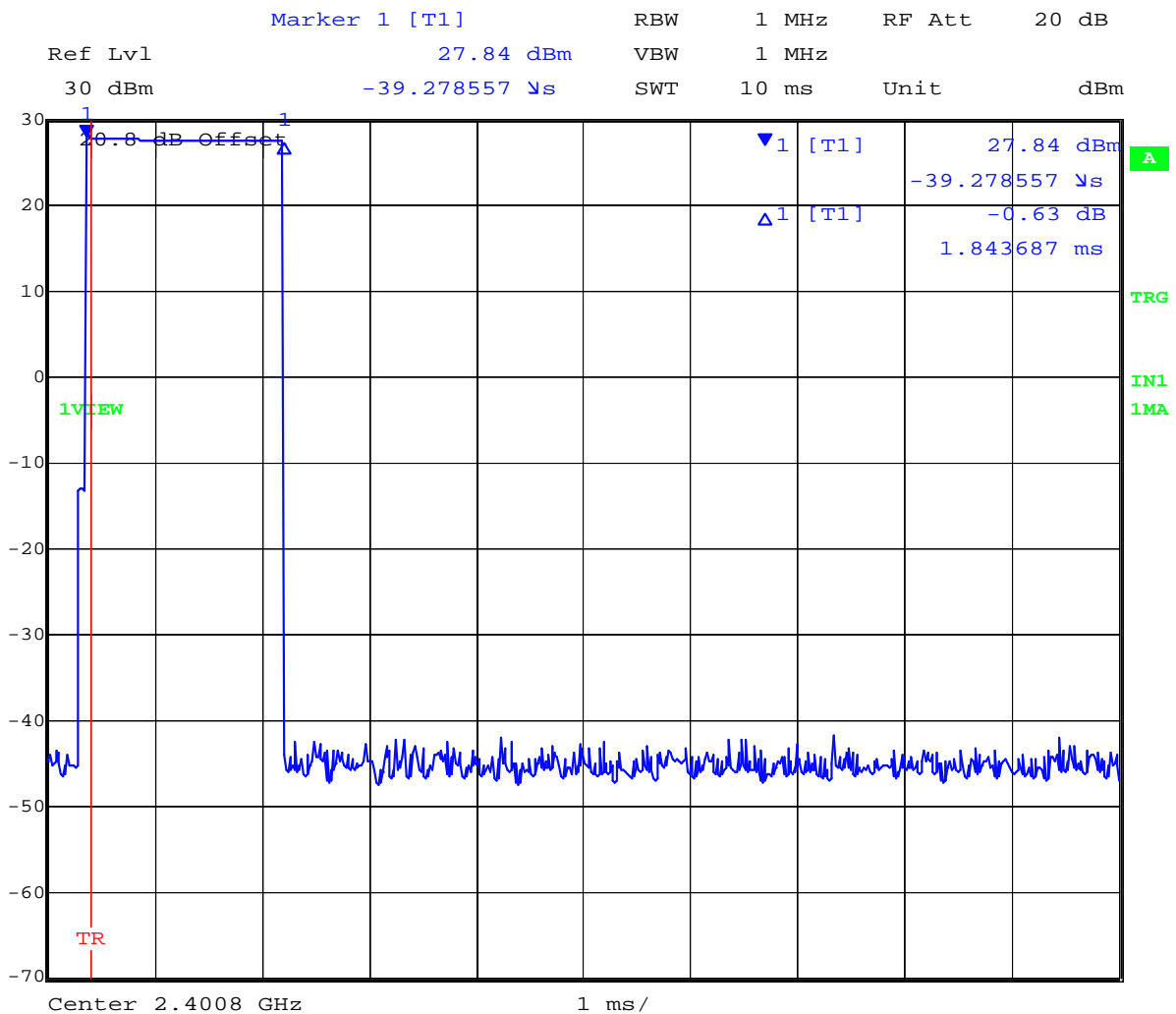

Date: 8.JUL.2013 13:55:26

This test report may be reproduced in full only. The document may only be updated by MiCOM Labs personnel. Any changes will be noted in the Document History section of the report.



4. Channel Occupancy

Channel (MHz)	# of Hops in 10 Secs	Dwell Time mS	Channel Occupancy mS	Compliant
2400.8	6	1.844	11.064	√

Channel Occupancy

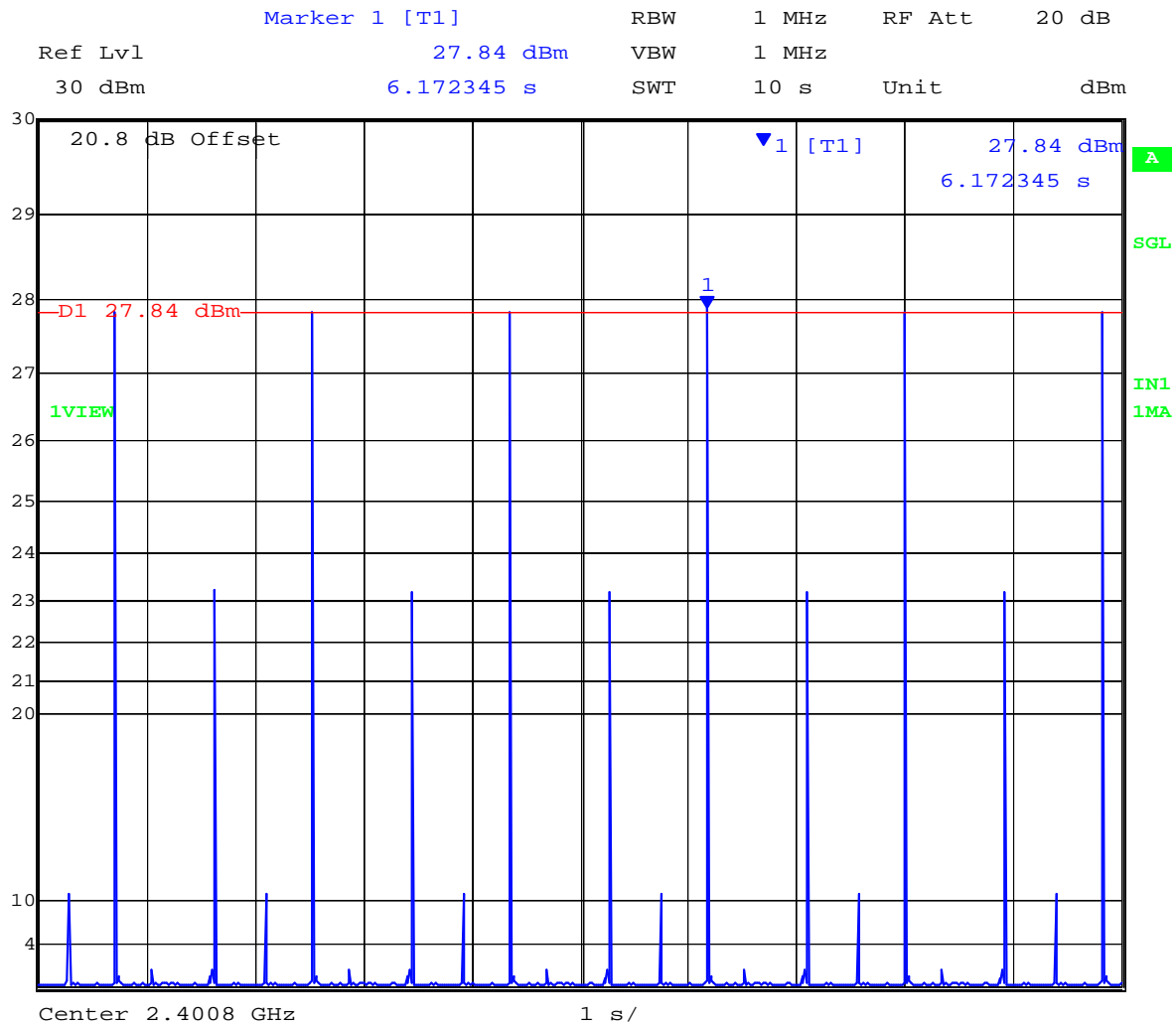

Date: 8.JUL.2013 13:52:39

This test report may be reproduced in full only. The document may only be updated by MiCOM Labs personnel. Any changes will be noted in the Document History section of the report.



Specification for Number of Channels and Channel Occupancy

Limits

FCC, Part 15 Subpart C §15.247(a)(1)
Industry Canada RSS-210 §A8.1

For frequency hopping systems operating in the 902-928 MHz band: if the 20 dB bandwidth of the hopping channel is less than 250 kHz, the system shall use at least 50 hopping frequencies and the average time of occupancy on any frequency shall not be greater than 0.4 seconds within a 20 second period; if the 20 dB bandwidth of the hopping channel is 250 kHz or greater, the system shall use at least 25 hopping frequencies and the average time of occupancy on any frequency shall not be greater than 0.4 seconds within a 10 second period. The maximum allowed 20 dB bandwidth of the hopping channel is 500 kHz

(iii) Frequency hopping systems in the 2400–2483.5 MHz band shall use at least 15 channels. The average time of occupancy on any channel shall not be greater than 0.4 seconds within a period of 0.4 seconds multiplied by the number of hopping channels employed. Frequency hopping systems may avoid or suppress transmissions on a particular hopping frequency provided that a minimum of 15 channels are used.

Laboratory Uncertainty for Frequency Measurements

Measurement uncertainty	±0.86ppm
-------------------------	----------

Traceability

Method	Test Equipment Used
Measurements were made per work instruction WI-02 'Frequency Measurement'	0078, 0134, 0158, 0184, 0193, 0250, 0252 0310, 0312.



6.1.3. Output Power

FCC, Part 15 Subpart C §15.247(b)(2)
Industry Canada RSS-210 §A8.4

Test Procedure

The transmitter terminal of EUT was set for CW (continuous wave) operation and connected to the input of the power meter which was calibrated to measure power. The value of measured power including antenna cable loss was reported.

15.247 (c) Operation with directional antenna gains greater than 6 dBi.
If transmitting antennas of directional gain greater than 6 dBi are used, the conducted output power from the intentional radiator shall be reduced by the amount in dB that the directional gain of the antenna exceeds 6 dBi.

Antenna Model	Frequency Band	Gain (dBi)	Max. Allowable Conducted Peak Power (dBm)	Maximum EIRP (dBm)
WPANT30017-CA	900 MHz	3.0	+30.0	+33.0
155-0010-00		1.2		+31.2
WPANT30017-CA	2.4 GHz	4.0	+30.0	+34.0
155-0010-00		5.6		+35.6

Section 4.1 Conducted RF Emission Test Set-up identifies the test configuration



Title: Silver Spring Network MicroAP
To: FCC 47 CFR Part15.247 & IC RSS-210
Serial #: SSNT62-U2 Rev A
Issue Date: 13th August 2013
Page: 56 of 147

6.1.3.1. 900 MHz FHSS

Equipment Configuration for Peak Output Power
--

Variant: FHSS	Duty Cycle (%): 100
Data Rate: 100 kBit/s	Antenna Gain (dBi): 3.00
Modulation: FSK	Beam Forming Gain (Y): Not Applicable
TPC: Not Applicable	
Engineering Test Notes: Integral Antenna	

Test Measurement Results

Test Frequency	Measured Output Power (dBm)				Calculated Total Power Σ Port(s)	Limit	Margin	EUT Power Setting
	Port(s)							
MHz	a	b	c	d	dBm	dBm	dBm	
902.3	29.82	--	--	--	29.82	30.00	-0.18	46.00
915.2	29.71	--	--	--	29.71	30.00	-0.29	46.00
927.5	29.74	--	--	--	29.74	30.00	-0.26	46.00

Traceability to Industry Recognized Test Methodologies

Work Instruction:	WI-01 MEASURING RF OUTPUT POWER
Measurement Uncertainty:	± 1.33 dB

Equipment Configuration for Peak Output Power
--

Variant: FHSS	Duty Cycle (%): 100
Data Rate: 100 kBit/s	Antenna Gain (dBi): 3.00
Modulation: FSK	Beam Forming Gain (Y): Not Applicable
TPC: Not Applicable	
Engineering Test Notes: External Antenna	

Test Measurement Results

Test Frequency	Measured Output Power (dBm)				Calculated Total Power Σ Port(s)	Limit	Margin	EUT Power Setting
	Port(s)							
MHz	a	b	c	d	dBm	dBm	dBm	
902.3	29.93	--	--	--	29.93	30.00	-0.07	60.00
915.2	29.85	--	--	--	29.85	30.00	-0.15	58.00
927.5	29.80	--	--	--	29.80	30.00	-0.20	58.00

Traceability to Industry Recognized Test Methodologies

Work Instruction:	WI-01 MEASURING RF OUTPUT POWER
Measurement Uncertainty:	± 1.33 dB

This test report may be reproduced in full only. The document may only be updated by MiCOM Labs personnel. Any changes will be noted in the Document History section of the report.



Title: Silver Spring Network MicroAP
To: FCC 47 CFR Part15.247 & IC RSS-210
Serial #: SSNT62-U2 Rev A
Issue Date: 13th August 2013
Page: 57 of 147

Equipment Configuration for Peak Output Power

Variant:	FHSS	Duty Cycle (%):	100
Data Rate:	100 kBit/s	Antenna Gain (dBi):	3.00
Modulation:	GFSK	Beam Forming Gain (Y):	Not Applicable
TPC:	Not Applicable		
Engineering Test Notes:	Integral Transmitter		

Test Measurement Results

Test Frequency	Measured Output Power (dBm)				Calculated Total Power Σ Port(s)	Limit	Margin	EUT Power Setting
	Port(s)							
MHz	a	b	c	d	dBm	dBm	dBm	
902.2	29.99	--	--	--	29.83	30.00	-0.17	46.00
915.0	29.75	--	--	--	29.75	30.00	-0.25	46.00
927.8	29.58	--	--	--	29.58	30.00	-0.42	46.00

Traceability to Industry Recognized Test Methodologies

Work Instruction:	WI-01 MEASURING RF OUTPUT POWER
Measurement Uncertainty:	± 1.33 dB

Equipment Configuration for Peak Output Power

Variant:	FHSS	Duty Cycle (%):	100
Data Rate:	100 kBit/s	Antenna Gain (dBi):	3.00
Modulation:	GFSK	Beam Forming Gain (Y):	Not Applicable
TPC:	Not Applicable		
Engineering Test Notes:	External Transmitter		

Test Measurement Results

Test Frequency	Measured Output Power (dBm)				Calculated Total Power Σ Port(s)	Limit	Margin	EUT Power Setting
	Port(s)							
MHz	a	b	c	d	dBm	dBm	dBm	
902.2	29.93	--	--	--	29.88	30.00	-0.12	58.00
915.0	29.85	--	--	--	29.85	30.00	-0.15	58.00
927.8	29.81	--	--	--	29.81	30.00	-0.19	58.00

Traceability to Industry Recognized Test Methodologies

Work Instruction:	WI-01 MEASURING RF OUTPUT POWER
Measurement Uncertainty:	± 1.33 dB

This test report may be reproduced in full only. The document may only be updated by MiCOM Labs personnel. Any changes will be noted in the Document History section of the report.



Title: Silver Spring Network MicroAP
To: FCC 47 CFR Part15.247 & IC RSS-210
Serial #: SSNT62-U2 Rev A
Issue Date: 13th August 2013
Page: 58 of 147

Equipment Configuration for Peak Output Power

Variant:	FHSS	Duty Cycle (%):	100
Data Rate:	150 kBit/s	Antenna Gain (dBi):	3.00
Modulation:	GFSK	Beam Forming Gain (Y):	Not Applicable
TPC:	Not Applicable		
Engineering Test Notes:	Integral Antenna		

Test Measurement Results

Test Frequency	Measured Output Power (dBm)				Calculated Total Power Σ Port(s)	Limit	Margin	EUT Power Setting
	Port(s)							
MHz	a	b	c	d	dBm	dBm	dBm	
902.3	29.69	--	--	--	29.69	30.00	-0.31	44.00
915.2	29.54	--	--	--	29.54	30.00	-0.46	44.00
927.5	29.36	--	--	--	29.36	30.00	-0.64	44.00

Traceability to Industry Recognized Test Methodologies

Work Instruction:	WI-01 MEASURING RF OUTPUT POWER
Measurement Uncertainty:	± 1.33 dB

Equipment Configuration for Peak Output Power

Variant:	FHSS	Duty Cycle (%):	100
Data Rate:	150 kBit/s	Antenna Gain (dBi):	3.00
Modulation:	GFSK	Beam Forming Gain (Y):	Not Applicable
TPC:	Not Applicable		
Engineering Test Notes:	External Antenna		

Test Measurement Results

Test Frequency	Measured Output Power (dBm)				Calculated Total Power Σ Port(s)	Limit	Margin	EUT Power Setting
	Port(s)							
MHz	a	b	c	d	dBm	dBm	dBm	
902.3	29.88	--	--	--	29.88	30.00	-0.12	58.00
915.2	29.85	--	--	--	29.85	30.00	-0.15	58.00
927.5	29.80	--	--	--	29.80	30.00	-0.20	58.00

Traceability to Industry Recognized Test Methodologies

Work Instruction:	WI-01 MEASURING RF OUTPUT POWER
Measurement Uncertainty:	± 1.33 dB

This test report may be reproduced in full only. The document may only be updated by MiCOM Labs personnel. Any changes will be noted in the Document History section of the report.



Title: Silver Spring Network MicroAP
To: FCC 47 CFR Part15.247 & IC RSS-210
Serial #: SSNT62-U2 Rev A
Issue Date: 13th August 2013
Page: 59 of 147

Equipment Configuration for Peak Output Power

Variant:	FHSS	Duty Cycle (%):	100
Data Rate:	300 kBit/s	Antenna Gain (dBi):	3.00
Modulation:	GFSK	Beam Forming Gain (Y):	Not Applicable
TPC:	Not Applicable		
Engineering Test Notes:	Integral Antenna		

Test Measurement Results

Test Frequency	Measured Output Power (dBm)				Calculated Total Power Σ Port(s)	Limit	Margin	EUT Power Setting
	Port(s)							
MHz	a	b	c	d	dBm	dBm	dBm	
902.4	29.83	--	--	--	29.83	30.00	-0.17	46.00
915.2	29.67	--	--	--	29.67	30.00	-0.33	46.00
927.6	29.49	--	--	--	29.49	30.00	-0.51	46.00

Traceability to Industry Recognized Test Methodologies

Work Instruction:	WI-01 MEASURING RF OUTPUT POWER
Measurement Uncertainty:	± 1.33 dB

Equipment Configuration for Peak Output Power

Variant:	FHSS	Duty Cycle (%):	100
Data Rate:	300 kBit/s	Antenna Gain (dBi):	3.00
Modulation:	GFSK	Beam Forming Gain (Y):	Not Applicable
TPC:	Not Applicable		
Engineering Test Notes:	External Antenna		

Test Measurement Results

Test Frequency	Measured Output Power (dBm)				Calculated Total Power Σ Port(s)	Limit	Margin	EUT Power Setting
	Port(s)							
MHz	a	b	c	d	dBm	dBm	dBm	
902.4	29.89	--	--	--	29.89	30.00	-0.11	58.00
915.2	29.83	--	--	--	29.83	30.00	-0.17	58.00
927.6	29.78	--	--	--	29.78	30.00	-0.22	58.00

Traceability to Industry Recognized Test Methodologies

Work Instruction:	WI-01 MEASURING RF OUTPUT POWER
Measurement Uncertainty:	± 1.33 dB

This test report may be reproduced in full only. The document may only be updated by MiCOM Labs personnel. Any changes will be noted in the Document History section of the report.



Title: Silver Spring Network MicroAP
To: FCC 47 CFR Part15.247 & IC RSS-210
Serial #: SSNT62-U2 Rev A
Issue Date: 13th August 2013
Page: 60 of 147

6.1.3.2. 2.4 GHz FHSS

Equipment Configuration for Peak Output Power
--

Variant:	FHSS	Duty Cycle (%):	100
Data Rate:	250 kBit/s	Antenna Gain (dBi):	4.00
Modulation:	GFSK	Beam Forming Gain (Y):	Not Applicable
TPC:	Not Applicable		
Engineering Test Notes:	Internal Antenna		

Test Measurement Results

Test Frequency	Measured Output Power (dBm)				Calculated Total Power Σ Port(s)	Limit	Margin	EUT Power Setting
	Port(s)							
MHz	a	b	c	d	dBm	dBm	dBm	
2400.8	27.18	--	--	--	27.18	30.00	-2.82	15.00
2440.0	26.19	--	--	--	26.19	30.00	-3.81	15.00
2472.8	25.97	--	--	--	25.97	30.00	-4.03	15.00

Traceability to Industry Recognized Test Methodologies

Work Instruction:	WI-01 MEASURING RF OUTPUT POWER
Measurement Uncertainty:	± 1.33 dB

Equipment Configuration for Peak Output Power
--

Variant:	FHSS	Duty Cycle (%):	100
Data Rate:	250 kBit/s	Antenna Gain (dBi):	4.00
Modulation:	GFSK	Beam Forming Gain (Y):	Not Applicable
TPC:	Not Applicable		
Engineering Test Notes:	External Antenna		

Test Measurement Results

Test Frequency	Measured Output Power (dBm)				Calculated Total Power Σ Port(s)	Limit	Margin	EUT Power Setting
	Port(s)							
MHz	a	b	c	d	dBm	dBm	dBm	
2400.8	24.10	--	--	--	24.10	30.00	-5.90	15.00
2440.0	24.49	--	--	--	24.49	30.00	-5.01	15.00
2472.8	24.49	--	--	--	24.49	30.00	-5.51	15.00

Traceability to Industry Recognized Test Methodologies

Work Instruction:	WI-01 MEASURING RF OUTPUT POWER
Measurement Uncertainty:	± 1.33 dB

This test report may be reproduced in full only. The document may only be updated by MiCOM Labs personnel. Any changes will be noted in the Document History section of the report.



Title: Silver Spring Network MicroAP
To: FCC 47 CFR Part15.247 & IC RSS-210
Serial #: SSNT62-U2 Rev A
Issue Date: 13th August 2013
Page: 61 of 147

Equipment Configuration for Peak Output Power

Variant:	FHSS	Duty Cycle (%):	100
Data Rate:	500 kBit/s	Antenna Gain (dBi):	4.00
Modulation:	GFSK	Beam Forming Gain (Y):	Not Applicable
TPC:	Not Applicable		
Engineering Test Notes:	Integral Antenna		

Test Measurement Results

Test Frequency	Measured Output Power (dBm)				Calculated Total Power Σ Port(s)	Limit	Margin	EUT Power Setting
	Port(s)							
MHz	a	b	c	d	dBm	dBm	dBm	
2400.8	27.44	--	--	--	27.44	30.00	-2.56	15.00
2440.0	26.19	--	--	--	26.19	30.00	-3.81	15.00
2472.8	25.97	--	--	--	25.97	30.00	-4.03	15.00

Traceability to Industry Recognized Test Methodologies

Work Instruction:	WI-01 MEASURING RF OUTPUT POWER
Measurement Uncertainty:	± 1.33 dB

Equipment Configuration for Peak Output Power

Variant:	FHSS	Duty Cycle (%):	100
Data Rate:	500 kBit/s	Antenna Gain (dBi):	4.00
Modulation:	GFSK	Beam Forming Gain (Y):	Not Applicable
TPC:	Not Applicable		
Engineering Test Notes:	External Antenna		

Test Measurement Results

Test Frequency	Measured Output Power (dBm)				Calculated Total Power Σ Port(s)	Limit	Margin	EUT Power Setting
	Port(s)							
MHz	a	b	c	d	dBm	dBm	dBm	
2400.8	23.93	--	--	--	23.93	30.00	-6.07	15.00
2440.0	24.49	--	--	--	24.49	30.00	-5.51	15.00
2472.8	24.58	--	--	--	24.58	30.00	-5.42	15.00

Traceability to Industry Recognized Test Methodologies

Work Instruction:	WI-01 MEASURING RF OUTPUT POWER
Measurement Uncertainty:	± 1.33 dB

This test report may be reproduced in full only. The document may only be updated by MiCOM Labs personnel. Any changes will be noted in the Document History section of the report.



Specification

Limits

FCC, Part 15 Subpart C §15.247 (b)(2)

The maximum output power of the intentional radiator shall not exceed the following:

(1) Frequency hopping systems shall have hopping channel carrier frequencies separated by a minimum of 25 kHz or the 20 dB bandwidth of the hopping channel, whichever is greater. Alternatively, frequency hopping systems operating in the 2400–2483.5 MHz band may have hopping channel carrier frequencies that are separated by 25 kHz or two-thirds of the 20 dB bandwidth of the hopping channel, whichever is greater, provided the systems operate with an output power no greater than 125 mW.

(2) For frequency hopping systems operating in the 902-928 MHz band: 1 watt for systems employing at least 50 hopping channels; and, 0.25 watts for systems employing less than 50 hopping channels, but at least 25 hopping channels, as permitted under paragraph (a)(1)(i) of this section.

Industry Canada RSS-210 §A8.1

(b) Frequency hopping systems shall have hopping channel carrier frequencies separated by a minimum of 25 kHz or the -20 dB bandwidth of the hopping channel, whichever is greater. Alternatively, frequency hopping systems operating in the band 2400-2483.5 MHz may have hopping channel carrier frequencies that are separated by 25 kHz or two-thirds of the -20 dB bandwidth of the hopping channel, whichever is greater, provided that the systems operate with an output power no greater than 0.125 W. The system receivers shall have input bandwidths that match the hopping channel bandwidths of their corresponding transmitters and shall shift frequencies in synchronization with the transmitted signals.

(c) For frequency hopping systems operating in the band 902–928 MHz, the maximum peak conducted output power shall not exceed 1.0 W, and the e.i.r.p. shall not exceed 4 W if the hopset uses 50 or more hopping channels; the maximum peak conducted output power shall not exceed 0.25 W, and the e.i.r.p. shall not exceed 1 W if the hopset uses less than 50 hopping channels.

Laboratory Measurement Uncertainty for Power Measurements

Measurement uncertainty	±1.33 dB
-------------------------	----------

Traceability

Method	Test Equipment Used
Measurements were made per work instruction WI-01 'Measuring RF Output Power'	0158, 0193, 0252, 0313, 0314, 0070, 0116, 0117

This test report may be reproduced in full only. The document may only be updated by MiCOM Labs personnel. Any changes will be noted in the Document History section of the report.



Title: Silver Spring Network MicroAP
To: FCC 47 CFR Part15.247 & IC RSS-210
Serial #: SSNT62-U2 Rev A
Issue Date: 13th August 2013
Page: 63 of 147

6.1.4. Conducted Spurious Emissions Transmitter

FCC, Part 15 Subpart C §15.247(d)
Industry Canada RSS-210 §A8.5

Test Procedure

Conducted emissions were measured at a limit of 20 dB below the highest in-band spectral density measured with a spectrum analyzer connected to the antenna terminal. Emissions at the band edge were measured and recorded. Measurements were made while EUT was operating in transmit mode of operation at the appropriate center frequency.

Section 4.1 Conducted RF Emission Test Set-up identifies the test configuration

This test report may be reproduced in full only. The document may only be updated by MiCOM Labs personnel. Any changes will be noted in the Document History section of the report.



Title: Silver Spring Network MicroAP
To: FCC 47 CFR Part15.247 & IC RSS-210
Serial #: SSNT62-U2 Rev A
Issue Date: 13th August 2013
Page: 64 of 147

6.1.4.1. 900 MHz FHSS

Equipment Configuration for Transmitter Conducted Spurious and Band-Edge Emissions

Variant:	FHSS	Duty Cycle (%):	100
Data Rate:	100 kBit/s	Antenna Gain (dBi):	Not Applicable
Modulation:	FSK	Beam Forming Gain (Y):	Not Applicable
TPC:	Not Applicable		
Engineering Test Notes:			

Test Measurement Results

Test Frequency	Frequency Range	Transmitter Conducted Spurious Emissions (dBm)							
		Port a		Port b		Port c		Port d	
MHz	MHz	SE	Limit	SE	Limit	SE	Limit	SE	Limit
902.3	30-10000	-33.850	9.64	--	--	--	--	--	--
915.2	30-10000	-32.927	9.76	--	--	--	--	--	--
927.5	30-10000	-33.800	9.91	--	--	--	--	--	--

SE - Maximum spurious emission found

Test Frequency	Band-Edge Frequency	Transmitter Conducted Band-Edge Emissions (dBm)							
		Port a		Port b		Port c		Port d	
MHz	MHz	BE	Limit	BE	Limit	BE	Limit	BE	Limit
902.3	902.0	-0.469	9.95	--	--	--	--	--	--
927.5	928.0	-20.426	9.95	--	--	--	--	--	--

BE - Maximum band-edge emission found

Traceability to Industry Recognized Test Methodologies

Work Instruction:	WI-05 MEASUREMENT OF SPURIOUS EMISSIONS
Measurement Uncertainty:	≤40 GHz ±2.37 dB, > 40 GHz ±4.6 dB

This test report may be reproduced in full only. The document may only be updated by MiCOM Labs personnel. Any changes will be noted in the Document History section of the report.



Title: Silver Spring Network MicroAP
To: FCC 47 CFR Part15.247 & IC RSS-210
Serial #: SSNT62-U2 Rev A
Issue Date: 13th August 2013
Page: 65 of 147

Equipment Configuration for Transmitter Conducted Spurious and Band-Edge Emissions

Variant:	FHSS	Duty Cycle (%):	100
Data Rate:	100 kBit/s	Antenna Gain (dBi):	Not Applicable
Modulation:	GFSK	Beam Forming Gain (Y):	Not Applicable
TPC:	Not Applicable		
Engineering Test Notes:			

Test Measurement Results

Test Frequency	Frequency Range	Transmitter Conducted Spurious Emissions (dBm)							
		Port a		Port b		Port c		Port d	
MHz	MHz	SE	Limit	SE	Limit	SE	Limit	SE	Limit
902.2	30-10000	-33.995	9.62	--	--	--	--	--	--
915.0	30-10000	-34.078	9.76	--	--	--	--	--	--
927.8	30-10000	-33.834	9.89	--	--	--	--	--	--

SE - Maximum spurious emission found

Test Frequency	Band-Edge Frequency	Transmitter Conducted Band-Edge Emissions (dBm)							
		Port a		Port b		Port c		Port d	
MHz	MHz	BE	Limit	BE	Limit	BE	Limit	BE	Limit
902.2	902.0	-15.047	9.92	--	--	--	--	--	--
927.8	928.0	9.931	9.95	--	--	--	--	--	--

BE - Maximum band-edge emission found

Traceability to Industry Recognized Test Methodologies

Work Instruction:	WI-05 MEASUREMENT OF SPURIOUS EMISSIONS
Measurement Uncertainty:	≤40 GHz ±2.37 dB, > 40 GHz ±4.6 dB

This test report may be reproduced in full only. The document may only be updated by MiCOM Labs personnel. Any changes will be noted in the Document History section of the report.



Title: Silver Spring Network MicroAP
To: FCC 47 CFR Part15.247 & IC RSS-210
Serial #: SSNT62-U2 Rev A
Issue Date: 13th August 2013
Page: 66 of 147

Equipment Configuration for Transmitter Conducted Spurious and Band-Edge Emissions

Variant:	FHSS	Duty Cycle (%):	100
Data Rate:	150 kBit/s	Antenna Gain (dBi):	Not Applicable
Modulation:	GFSK	Beam Forming Gain (Y):	Not Applicable
TPC:	Not Applicable		
Engineering Test Notes:			

Test Measurement Results

Test Frequency	Frequency Range	Transmitter Conducted Spurious Emissions (dBm)							
		Port a		Port b		Port c		Port d	
MHz	MHz	SE	Limit	SE	Limit	SE	Limit	SE	Limit
902.3	30-10000	-33.647	9.46	--	--	--	--	--	--
915.2	30-10000	-33.787	9.64	--	--	--	--	--	--
927.5	30-10000	-34.072	9.76	--	--	--	--	--	--

SE - Maximum spurious emission found

Test Frequency	Band-Edge Frequency	Transmitter Conducted Band-Edge Emissions (dBm)							
		Port a		Port b		Port c		Port d	
MHz	MHz	BE	Limit	BE	Limit	BE	Limit	BE	Limit
902.3	902.0	-2.173	9.78	--	--	--	--	--	--
927.5	928.0	-21.018	9.79	--	--	--	--	--	--

BE - Maximum band-edge emission found

Traceability to Industry Recognized Test Methodologies

Work Instruction:	WI-05 MEASUREMENT OF SPURIOUS EMISSIONS
Measurement Uncertainty:	≤40 GHz ±2.37 dB, > 40 GHz ±4.6 dB

This test report may be reproduced in full only. The document may only be updated by MiCOM Labs personnel. Any changes will be noted in the Document History section of the report.



Title: Silver Spring Network MicroAP
To: FCC 47 CFR Part15.247 & IC RSS-210
Serial #: SSNT62-U2 Rev A
Issue Date: 13th August 2013
Page: 67 of 147

Equipment Configuration for Transmitter Conducted Spurious and Band-Edge Emissions

Variant:	FHSS	Duty Cycle (%):	100
Data Rate:	300 kBit/s	Antenna Gain (dBi):	Not Applicable
Modulation:	GFSK	Beam Forming Gain (Y):	Not Applicable
TPC:	Not Applicable		
Engineering Test Notes:			

Test Measurement Results

Test Frequency	Frequency Range	Transmitter Conducted Spurious Emissions (dBm)							
		Port a		Port b		Port c		Port d	
MHz	MHz	SE	Limit	SE	Limit	SE	Limit	SE	Limit
902.4	30-10000	-33.757	9.18	--	--	--	--	--	--
915.2	30-10000	-33.492	9.16	--	--	--	--	--	--
927.6	30-10000	-33.244	9.36	--	--	--	--	--	--

SE - Maximum spurious emission found

Test Frequency	Band-Edge Frequency	Transmitter Conducted Band-Edge Emissions (dBm)							
		Port a		Port b		Port c		Port d	
MHz	MHz	BE	Limit	BE	Limit	BE	Limit	BE	Limit
902.4	902.0	-5.132	9.58	--	--	--	--	--	--
927.6	928.0	-4.093	9.45	--	--	--	--	--	--

BE - Maximum band-edge emission found

Traceability to Industry Recognized Test Methodologies

Work Instruction:	WI-05 MEASUREMENT OF SPURIOUS EMISSIONS
Measurement Uncertainty:	≤ 40 GHz ±2.37 dB, > 40 GHz ±4.6 dB

This test report may be reproduced in full only. The document may only be updated by MiCOM Labs personnel. Any changes will be noted in the Document History section of the report.



Title: Silver Spring Network MicroAP
To: FCC 47 CFR Part15.247 & IC RSS-210
Serial #: SSNT62-U2 Rev A
Issue Date: 13th August 2013
Page: 68 of 147

6.1.4.2. 2.4 GHz FHSS

Equipment Configuration for Transmitter Conducted Spurious and Band-Edge Emissions

Variant: FHSS	Duty Cycle (%): 100
Data Rate: 250 kBit/s	Antenna Gain (dBi): Not Applicable
Modulation: GFSK	Beam Forming Gain (Y): Not Applicable
TPC: Not Applicable	
Engineering Test Notes: External Antenna Port	

Test Measurement Results

Test Frequency	Frequency Range	Transmitter Conducted Spurious Emissions (dBm)							
		Port a		Port b		Port c		Port d	
MHz	MHz	SE	Limit	SE	Limit	SE	Limit	SE	Limit
2400.8	30- 26000	-40.776	3.15	--	--	--	--	--	--
2440.0	30- 26000	-40.951	3.61	--	--	--	--	--	--
2472.8	30- 26000	-40.433	3.90	--	--	--	--	--	--

SE - Maximum spurious emission found

Test Frequency	Band-Edge Frequency	Transmitter Conducted Band-Edge Emissions (dBm)							
		Port a		Port b		Port c		Port d	
MHz	MHz	BE	Limit	BE	Limit	BE	Limit	BE	Limit
2400.8	2400.0	-30.748	3.23	--	--	--	--	--	--
2472.8	2483.5	-46.887	3.85	--	--	--	--	--	--

BE - Maximum band-edge emission found

Traceability to Industry Recognized Test Methodologies	
Work Instruction:	WI-05 MEASUREMENT OF SPURIOUS EMISSIONS
Measurement Uncertainty:	≤ 40 GHz ±2.37 dB, > 40 GHz ±4.6 dB

This test report may be reproduced in full only. The document may only be updated by MiCOM Labs personnel. Any changes will be noted in the Document History section of the report.



Title: Silver Spring Network MicroAP
To: FCC 47 CFR Part15.247 & IC RSS-210
Serial #: SSNT62-U2 Rev A
Issue Date: 13th August 2013
Page: 69 of 147

Equipment Configuration for Transmitter Conducted Spurious and Band-Edge Emissions

Variant:	FHSS	Duty Cycle (%):	100
Data Rate:	500 kBit/s	Antenna Gain (dBi):	Not Applicable
Modulation:	GFSK	Beam Forming Gain (Y):	Not Applicable
TPC:	Not Applicable		
Engineering Test Notes:	External Antenna Port		

Test Measurement Results

Test Frequency	Frequency Range	Transmitter Conducted Spurious Emissions (dBm)							
		Port a		Port b		Port c		Port d	
MHz	MHz	SE	Limit	SE	Limit	SE	Limit	SE	Limit
2400.8	30- 26000	-40.636	2.91	--	--	--	--	--	--
2440.0	30- 26000	-40.469	3.33	--	--	--	--	--	--
2472.8	30- 26000	-38.732	3.41	--	--	--	--	--	--

SE - Maximum spurious emission found

Test Frequency	Band-Edge Frequency	Transmitter Conducted Band-Edge Emissions (dBm)							
		Port a		Port b		Port c		Port d	
MHz	MHz	BE	Limit	BE	Limit	BE	Limit	BE	Limit
2400.8	2400.0	-24.585	3.07	--	--	--	--	--	--
2472.8	2483.5	-44.261	3.68	--	--	--	--	--	--

BE - Maximum band-edge emission found

Traceability to Industry Recognized Test Methodologies

Work Instruction:	WI-05 MEASUREMENT OF SPURIOUS EMISSIONS
Measurement Uncertainty:	≤ 40 GHz ±2.37 dB, > 40 GHz ±4.6 dB

This test report may be reproduced in full only. The document may only be updated by MiCOM Labs personnel. Any changes will be noted in the Document History section of the report.



Specification

Limits Band-Edge

Lower Limit Band-edge	Upper Limit Band-edge	Limit below highest level of desired power
902 MHz	928 MHz	≥ 20 dB
2400 MHz	2483.5 MHz	≥ 20 dB

FCC, Part 15 Subpart C §15.247(d)

Industry Canada RSS-210 §A.5

In any 100 kHz bandwidth outside the frequency band in which the spread spectrum or digitally modulated intentional radiator is operating, the radio frequency power that is produced by the intentional radiator shall be at least 20 dB below that in the 100 kHz bandwidth within the band that contains the highest level of the desired power, based on either an RF conducted or a radiated measurement, provided the transmitter demonstrates compliance with the peak conducted power limits.

Laboratory Measurement Uncertainty for Conducted Spurious Emissions

Measurement uncertainty	±2.37 dB
-------------------------	----------

Traceability

Method	Test Equipment Used
Measurements were made per work instruction WI-05 'Measurement of Spurious Emissions'	0287, 0158, 0193, 0252, 0313, 0314, 0070, 0116, 0117.

This test report may be reproduced in full only. The document may only be updated by MiCOM Labs personnel. Any changes will be noted in the Document History section of the report.

6.1.5. Radiated Emissions > 1 GHz

FCC, Part 15 Subpart C §15.247(d)
Industry Canada RSS-210 §A8.5

Test Procedure

Radiated emissions above 1 GHz are measured in the anechoic chamber at a 3-meter distance on every azimuth in both horizontal and vertical polarities. The emissions are recorded and maximized as a function of azimuth by rotation through 360° with a spectrum analyzer in peak hold mode. Depending on the frequency band spanned a notch filter and waveguide filter was used to remove the fundamental frequency. The highest emissions relative to the limit are listed for each frequency spanned.

All measurements on any frequency or frequencies over 1 MHz are based on the use of measurement instrumentation employing an average detector function. All measurements above 1 GHz were performed using a minimum resolution bandwidth of 1 MHz.

Test Measurement Set up

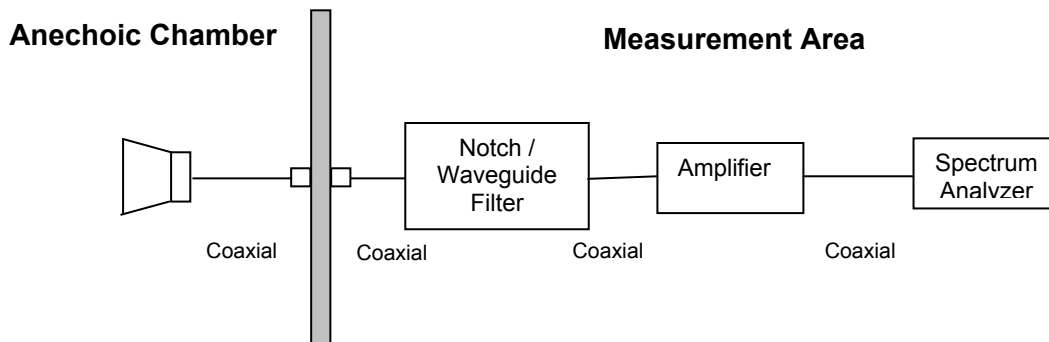

Measurement set up for Radiated Emission Test

Field Strength Calculation

The field strength is calculated by adding the Antenna Factor and Cable Loss, and subtracting Amplifier Gain from the measured reading. All factors are included in the reported data.

$$FS = R + AF + CORR - FO$$

where: FS = Field Strength

R = Measured Spectrum analyzer Input Amplitude

AF = Antenna Factor

CORR = Correction Factor = CL – AG + NFL

CL = Cable Loss

AG = Amplifier Gain

FO = Distance Falloff Factor

NFL = Notch Filter Loss or Waveguide Loss



Title: Silver Spring Network MicroAP
To: FCC 47 CFR Part15.247 & IC RSS-210
Serial #: SSNT62-U2 Rev A
Issue Date: 13th August 2013
Page: 72 of 147

For example:

Given receiver input reading of 51.5 dB μ V; Antenna Factor of 8.5 dB; Cable Loss of 1.3 dB; Falloff Factor of 0 dB, an Amplifier Gain of 26 dB and Notch Filter Loss of 1 dB. The Field Strength of the measured emission is:

$$FS = 51.5 + 8.5 + 1.3 - 26.0 + 1 = 36.3 \text{ dB}\mu\text{V/m}$$

Conversion between dB μ V/m (or dB μ V) and μ V/m (or μ V) are done as:

$$\text{Level (dB}\mu\text{V/m)} = 20 * \text{Log (level (\mu\text{V/m}))}$$

$$40 \text{ dB}\mu\text{V/m} = 100 \mu\text{V/m}$$

$$48 \text{ dB}\mu\text{V/m} = 250 \mu\text{V/m}$$

This test report may be reproduced in full only. The document may only be updated by MiCOM Labs personnel. Any changes will be noted in the Document History section of the report.



6.1.5.1. 900 MHz Integral Transmitter Radiated Spurious Emissions

Test Freq.	902.4 MHz;	Engineer	SB
Variant	Cont TX (GFSK 300 kbps)	Temp (°C)	29
Freq. Range	1000 MHz - 18000 MHz	Rel. Hum.(%)	30
Power Setting	ATS112=46	Press. (mBars)	997
Antenna	Integral	Duty Cycle (%)	100
Test Notes 1	NIC 411-3G-070B;		
Test Notes 2	4VDC		

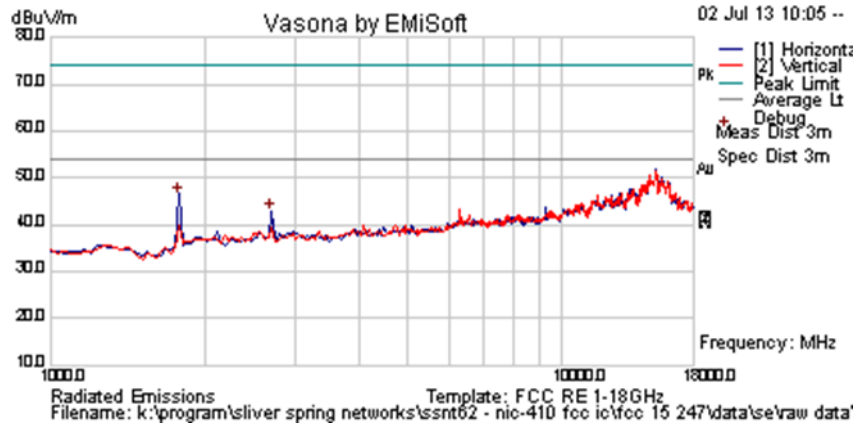

Formally measured emission peaks

Frequency MHz	Raw dBuV	Cable Loss	AF dB	Level dBuV/m	Measurement Type	Pol	Hgt cm	Azt Deg	Limit dBuV/m	Margin dB	Pass /Fail	Comments
1784.637	56.3	2.7	-12.9	46.2	Peak [Scan]	H	98	360	54.0	-7.9	Pass	NRB
2702.075	51.2	3.3	-11.7	42.8	Peak [Scan]	H	98	360	54.0	-11.2	Pass	RB

Legend: TX = Transmitter Emissions; DIG = Digital Emissions; FUND = Fundamental; WB = Wideband Emission
 RB = Restricted Band (15.209 Limits); NRB = Non Restricted Band, Limit is 20dB below fundamental peak

This test report may be reproduced in full only. The document may only be updated by MiCOM Labs personnel. Any changes will be noted in the Document History section of the report.



Title: Silver Spring Network MicroAP
To: FCC 47 CFR Part15.247 & IC RSS-210
Serial #: SSNT62-U2 Rev A
Issue Date: 13th August 2013
Page: 74 of 147

Test Freq.	915.2 MHz;	Engineer	SB
Variant	Cont TX (GFSK 300 kbps)	Temp (°C)	29
Freq. Range	1000 MHz - 18000 MHz	Rel. Hum.(%)	30
Power Setting	ATS112=46	Press. (mBars)	997
Antenna	Integral	Duty Cycle (%)	100
Test Notes 1	NIC 411-3G-070B;		
Test Notes 2	4VDC		

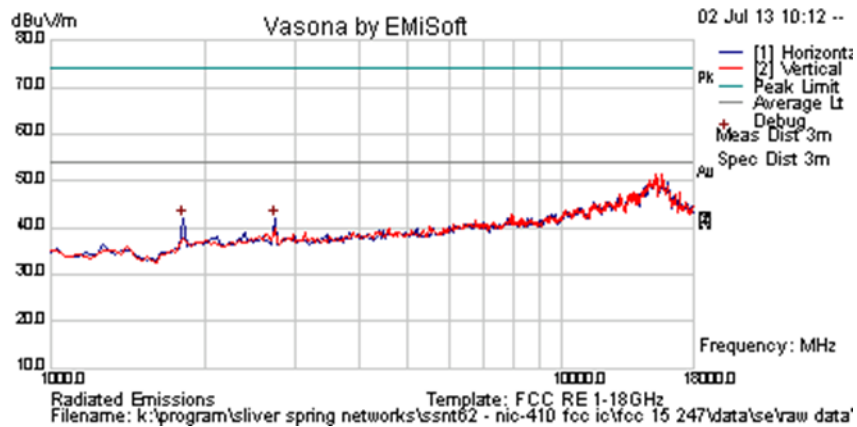

Formally measured emission peaks

Frequency MHz	Raw dBuV	Cable Loss	AF dB	Level dBuV/m	Measurement Type	Pol	Hgt cm	Azt Deg	Limit dBuV/m	Margin dB	Pass /Fail	Comments
1818.501	51.7	2.8	-12.5	41.9	Peak [Scan]	H	98	360	54.0	-12.1	Pass	NRB
2736.161	50.3	3.4	-11.7	42.0	Peak [Scan]	H	98	360	54.0	-12.0	Pass	RB

Legend: TX = Transmitter Emissions; DIG = Digital Emissions; FUND = Fundamental; WB = Wideband Emission
 RB = Restricted Band (15.209 Limits); NRB = Non Restricted Band, Limit is 20dB below fundamental peak

This test report may be reproduced in full only. The document may only be updated by MiCOM Labs personnel. Any changes will be noted in the Document History section of the report.



Title: Silver Spring Network MicroAP
To: FCC 47 CFR Part15.247 & IC RSS-210
Serial #: SSNT62-U2 Rev A
Issue Date: 13th August 2013
Page: 75 of 147

Test Freq.	927.6 MHz;	Engineer	SB
Variant	Cont TX (GFSK 300 kbps)	Temp (°C)	29
Freq. Range	1000 MHz - 18000 MHz	Rel. Hum.(%)	30
Power Setting	ATS112=46	Press. (mBars)	997
Antenna	Integral	Duty Cycle (%)	100
Test Notes 1	NIC 411-3G-070B;		
Test Notes 2	4VDC		

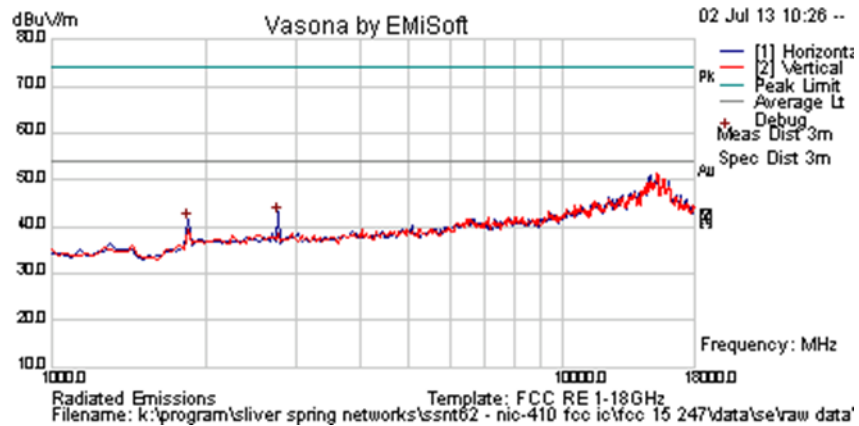

Formally measured emission peaks

Frequency MHz	Raw dBuV	Cable Loss	AF dB	Level dBuV/m	Measurement Type	Pol	Hgt cm	Azt Deg	Limit dBuV/m	Margin dB	Pass /Fail	Comments
1847.760	50.4	2.8	-12.4	40.7	Peak [Scan]	V	98	360	54.0	-13.3	Pass	NRB
2777.258	50.5	3.4	-11.7	42.1	Peak [Scan]	V	98	360	54.0	-11.9	Pass	RB

Legend: TX = Transmitter Emissions; DIG = Digital Emissions; FUND = Fundamental; WB = Wideband Emission
 RB = Restricted Band (15.209 Limits); NRB = Non Restricted Band, Limit is 20dB below fundamental peak

This test report may be reproduced in full only. The document may only be updated by MiCOM Labs personnel. Any changes will be noted in the Document History section of the report.



6.1.5.2. 900 MHz External Transmitter Radiated Spurious Emissions

Test Freq.	902.4 MHz;	Engineer	SB
Variant	Cont TX (GFSK 300 kbps)	Temp (°C)	29
Freq. Range	1000 MHz - 18000 MHz	Rel. Hum.(%)	30
Power Setting	ATS112=60	Press. (mBars)	997
Antenna	WP WPANT 30017-CA (4 dBi)	Duty Cycle (%)	100
Test Notes 1	NIC 411-3G-070B;		
Test Notes 2	4VDC		

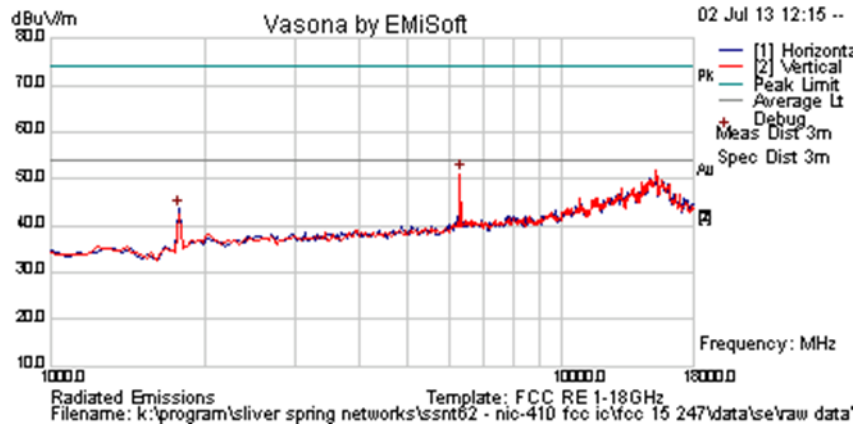

Formally measured emission peaks

Frequency MHz	Raw dBuV	Cable Loss	AF dB	Level dBuV/m	Measurement Type	Pol	Hgt cm	Azt Deg	Limit dBuV/m	Margin dB	Pass /Fail	Comments
6314.629	53.3	5.3	-7.5	51.1	Peak [Scan]	V	200	0	54.0	-2.9	Pass	NRB
1785.181	53.5	2.7	-12.9	43.3	Peak [Scan]	H	98	360	54.0	-10.7	Pass	NRB

Legend: TX = Transmitter Emissions; DIG = Digital Emissions; FUND = Fundamental; WB = Wideband Emission
 RB = Restricted Band (15.209 Limits); NRB = Non Restricted Band, Limit is 20dB below fundamental peak

This test report may be reproduced in full only. The document may only be updated by MiCOM Labs personnel. Any changes will be noted in the Document History section of the report.



Title: Silver Spring Network MicroAP
To: FCC 47 CFR Part15.247 & IC RSS-210
Serial #: SSNT62-U2 Rev A
Issue Date: 13th August 2013
Page: 77 of 147

Test Freq.	915.2 MHz;	Engineer	SB
Variant	Cont TX (GFSK 300 kbps)	Temp (°C)	29
Freq. Range	1000 MHz - 18000 MHz	Rel. Hum.(%)	30
Power Setting	ATS112=60	Press. (mBars)	997
Antenna	WP WPANT 30017-CA (4 dBi)	Duty Cycle (%)	100
Test Notes 1	NIC 411-3G-070B;		
Test Notes 2	4VDC		

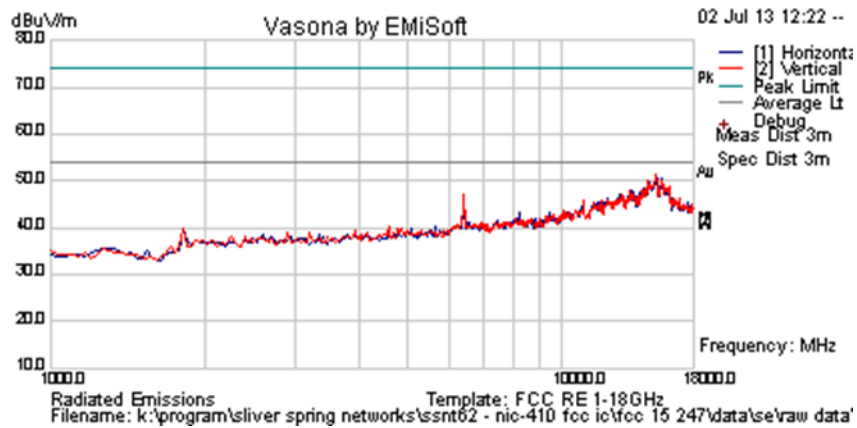

Formally measured emission peaks

Frequency MHz	Raw dBuV	Cable Loss	AF dB	Level dBuV/m	Measurement Type	Pol	Hgt cm	Azt Deg	Limit dBuV/m	Margin dB	Pass /Fail	Comments
---------------	----------	------------	-------	--------------	------------------	-----	--------	---------	--------------	-----------	------------	----------

No emissions observed within 6 dB of the limit.

Legend: TX = Transmitter Emissions; DIG = Digital Emissions; FUND = Fundamental; WB = Wideband Emission
 RB = Restricted Band (15.209 Limits); NRB = Non Restricted Band, Limit is 20dB below fundamental peak

This test report may be reproduced in full only. The document may only be updated by MiCOM Labs personnel. Any changes will be noted in the Document History section of the report.



Title: Silver Spring Network MicroAP
To: FCC 47 CFR Part15.247 & IC RSS-210
Serial #: SSNT62-U2 Rev A
Issue Date: 13th August 2013
Page: 78 of 147

Test Freq.	927.6 MHz;	Engineer	SB
Variant	Cont TX (GFSK 300 kbps)	Temp (°C)	29
Freq. Range	1000 MHz - 18000 MHz	Rel. Hum.(%)	30
Power Setting	ATS112=60	Press. (mBars)	997
Antenna	WP WPANT 30017-CA (4 dBi)	Duty Cycle (%)	100
Test Notes 1	NIC 411-3G-070B;		
Test Notes 2	4VDC		

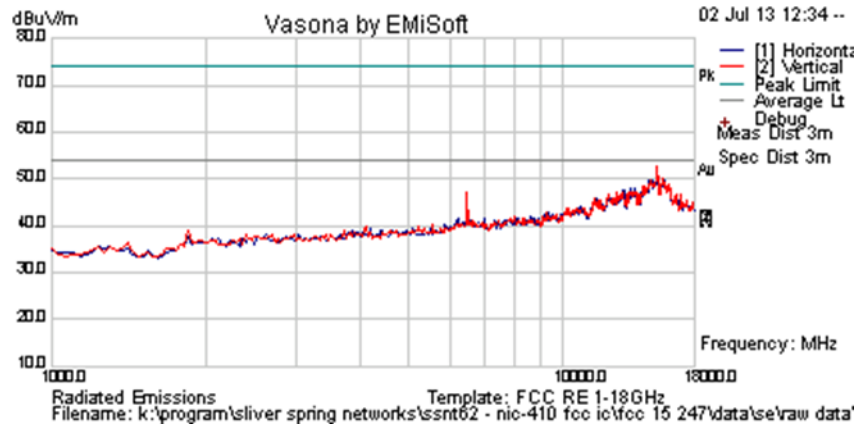

Formally measured emission peaks

Frequency MHz	Raw dBuV	Cable Loss	AF dB	Level dBuV/m	Measurement Type	Pol	Hgt cm	Azt Deg	Limit dBuV/m	Margin dB	Pass /Fail	Comments
---------------	----------	------------	-------	--------------	------------------	-----	--------	---------	--------------	-----------	------------	----------

No emissions observed within 6 dB of the limit.

Legend: TX = Transmitter Emissions; DIG = Digital Emissions; FUND = Fundamental; WB = Wideband Emission
 RB = Restricted Band (15.209 Limits); NRB = Non Restricted Band, Limit is 20dB below fundamental peak

This test report may be reproduced in full only. The document may only be updated by MiCOM Labs personnel. Any changes will be noted in the Document History section of the report.



Title: Silver Spring Network MicroAP
To: FCC 47 CFR Part15.247 & IC RSS-210
Serial #: SSNT62-U2 Rev A
Issue Date: 13th August 2013
Page: 79 of 147

6.1.5.3. 2400 MHz Integral Transmitter Radiated Spurious Emissions

Test Freq.	2400.8 MHz;	Engineer	SB
Variant	Cont TX (GFSK 500 kbps)	Temp (°C)	29
Freq. Range	1000 MHz - 18000 MHz	Rel. Hum.(%)	30
Power Setting	ATS112=15	Press. (mBars)	997
Antenna	Integral	Duty Cycle (%)	100
Test Notes 1	NIC 411-3G-070B;		
Test Notes 2	4VDC		

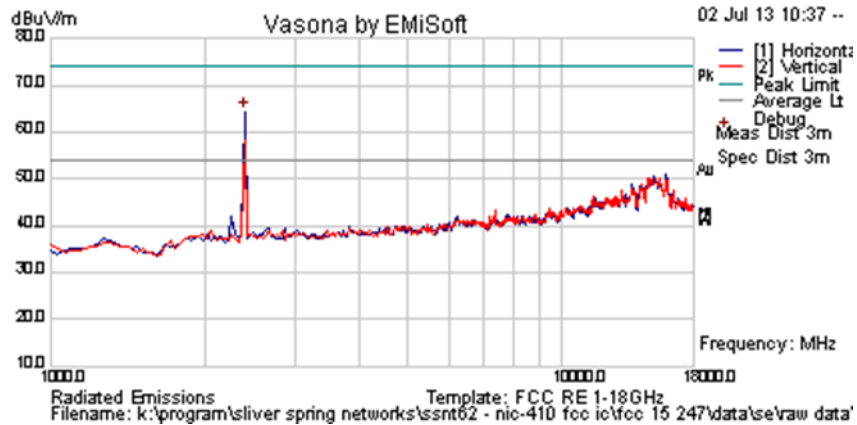

Formally measured emission peaks

Frequency MHz	Raw dBuV	Cable Loss	AF dB	Level dBuV/m	Measurement Type	Pol	Hgt cm	Azt Deg	Limit dBuV/m	Margin dB	Pass /Fail	Comments
2396.794	72.9	3.2	-11.7	64.4	Peak [Scan]	H	100					FUND
Legend: TX = Transmitter Emissions; DIG = Digital Emissions; FUND = Fundamental; WB = Wideband Emission RB = Restricted Band (15.209 Limits); NRB = Non Restricted Band, Limit is 20dB below fundamental peak												

This test report may be reproduced in full only. The document may only be updated by MiCOM Labs personnel. Any changes will be noted in the Document History section of the report.



Title: Silver Spring Network MicroAP
To: FCC 47 CFR Part15.247 & IC RSS-210
Serial #: SSNT62-U2 Rev A
Issue Date: 13th August 2013
Page: 80 of 147

Test Freq.	2440.0 MHz;	Engineer	SB
Variant	Cont TX (GFSK 500 kbps)	Temp (°C)	29
Freq. Range	1000 MHz - 18000 MHz	Rel. Hum.(%)	30
Power Setting	ATS112=15	Press. (mBars)	997
Antenna	Integral	Duty Cycle (%)	100
Test Notes 1	NIC 411-3G-070B;		
Test Notes 2	4VDC		

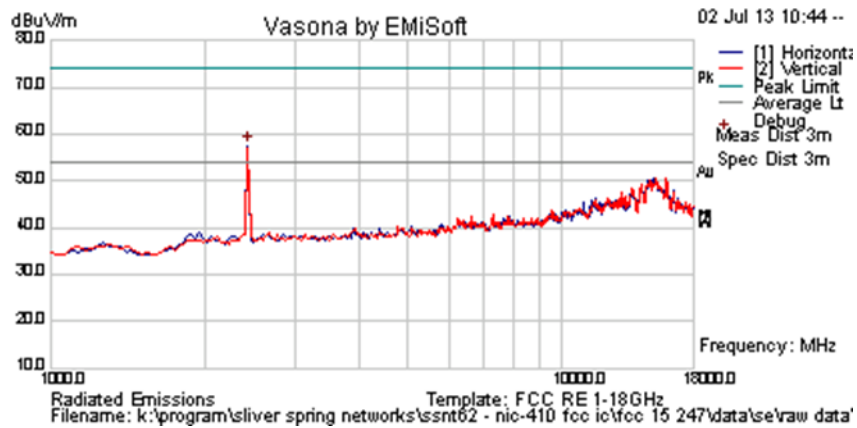

Formally measured emission peaks

Frequency MHz	Raw dBuV	Cable Loss	AF dB	Level dBuV/m	Measurement Type	Pol	Hgt cm	Azt Deg	Limit dBuV/m	Margin dB	Pass /Fail	Comments
2430.862	65.9	3.2	-11.6	57.5	Peak [Scan]	H	200					FUND

Legend: TX = Transmitter Emissions; DIG = Digital Emissions; FUND = Fundamental; WB = Wideband Emission
 RB = Restricted Band (15.209 Limits); NRB = Non Restricted Band, Limit is 20dB below fundamental peak

This test report may be reproduced in full only. The document may only be updated by MiCOM Labs personnel. Any changes will be noted in the Document History section of the report.



Title: Silver Spring Network MicroAP
To: FCC 47 CFR Part15.247 & IC RSS-210
Serial #: SSNT62-U2 Rev A
Issue Date: 13th August 2013
Page: 81 of 147

Test Freq.	2472.8 MHz;	Engineer	SB
Variant	Cont TX (GFSK 500 kbps)	Temp (°C)	29
Freq. Range	1000 MHz - 18000 MHz	Rel. Hum.(%)	30
Power Setting	ATS112=15	Press. (mBars)	997
Antenna	Integral	Duty Cycle (%)	100
Test Notes 1	NIC 411-3G-070B;		
Test Notes 2	4VDC		

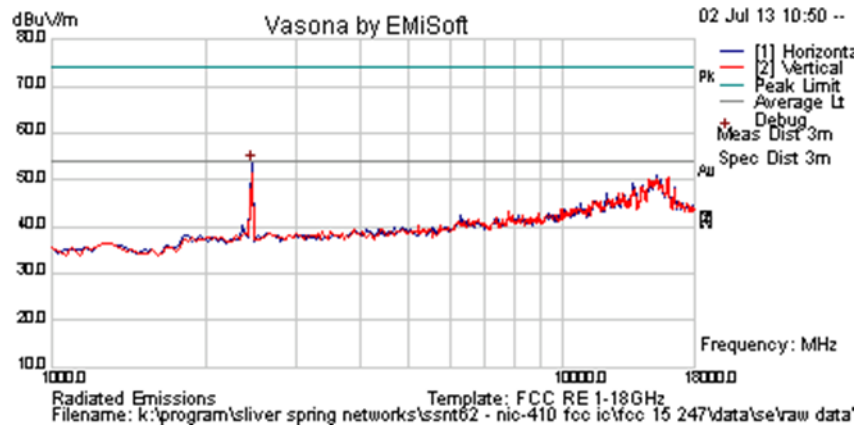

Formally measured emission peaks

Frequency MHz	Raw dBuV	Cable Loss	AF dB	Level dBuV/m	Measurement Type	Pol	Hgt cm	Azt Deg	Limit dBuV/m	Margin dB	Pass /Fail	Comments
2464.930	61.7	3.2	-11.5	53.4	Peak [Scan]	H	200					FUND

Legend: TX = Transmitter Emissions; DIG = Digital Emissions; FUND = Fundamental; WB = Wideband Emission
 RB = Restricted Band (15.209 Limits); NRB = Non Restricted Band, Limit is 20dB below fundamental peak

This test report may be reproduced in full only. The document may only be updated by MiCOM Labs personnel. Any changes will be noted in the Document History section of the report.



6.1.5.4. 2.4 GHz Integral Antenna Radiated Band-Edge

Integral Antenna

Operational Mode	2390 MHz			2483.5 MHz		
	dB μ V		Power Setting	dB μ V		Power Setting
	Peak	Average		Peak	Average	
DSSS	63.22	53.84	14	58.22	50.94	3
250 kBit/s	48.16	36.31	15	49.88	37.16	15
500 kBit/s	52.73	41.75	15	55.68	45.09	15

This test report may be reproduced in full only. The document may only be updated by MiCOM Labs personnel. Any changes will be noted in the Document History section of the report.



Title: Silver Spring Network MicroAP
To: FCC 47 CFR Part15.247 & IC RSS-210
Serial #: SSNT62-U2 Rev A
Issue Date: 13th August 2013
Page: 83 of 147

6.1.5.5. 2400 MHz External Transmitter Radiated Spurious Emissions

Test Freq.	2400.8 MHz;	Engineer	SB
Variant	Cont TX (GFSK 500 kbps)	Temp (°C)	29
Freq. Range	1000 MHz - 18000 MHz	Rel. Hum.(%)	30
Power Setting	ATS112=15	Press. (mBars)	997
Antenna	WP WPANT 30017-CA (4 dBi)	Duty Cycle (%)	100
Test Notes 1	NIC 411-3G-070B;		
Test Notes 2	4VDC		

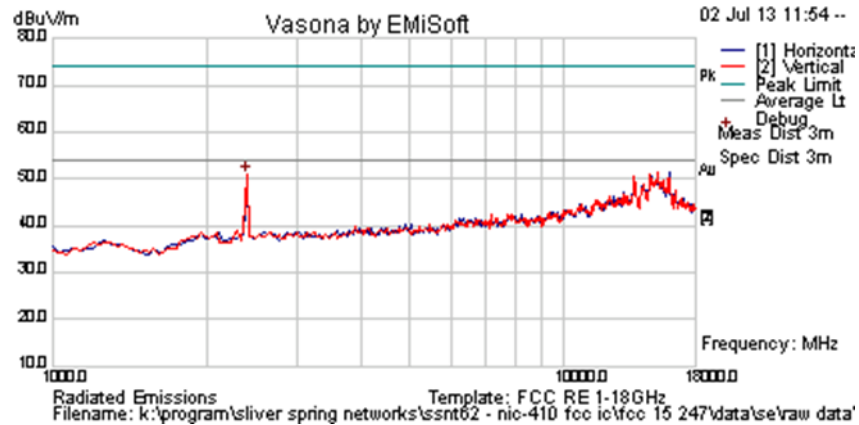

Formally measured emission peaks

Frequency MHz	Raw dBuV	Cable Loss	AF dB	Level dBuV/m	Measurement Type	Pol	Hgt cm	Azt Deg	Limit dBuV/m	Margin dB	Pass /Fail	Comments
2396.794	59.4	3.2	-11.7	50.9	Peak [Scan]	V	150					FUND
Legend: TX = Transmitter Emissions; DIG = Digital Emissions; FUND = Fundamental; WB = Wideband Emission RB = Restricted Band (15.209 Limits); NRB = Non Restricted Band, Limit is 20dB below fundamental peak												

This test report may be reproduced in full only. The document may only be updated by MiCOM Labs personnel. Any changes will be noted in the Document History section of the report.



Title: Silver Spring Network MicroAP
To: FCC 47 CFR Part15.247 & IC RSS-210
Serial #: SSNT62-U2 Rev A
Issue Date: 13th August 2013
Page: 84 of 147

Test Freq.	2440.0 MHz;	Engineer	SB
Variant	Cont TX (GFSK 500 kbps)	Temp (°C)	29
Freq. Range	1000 MHz - 18000 MHz	Rel. Hum.(%)	30
Power Setting	ATS112=15	Press. (mBars)	997
Antenna	WP WPANT 30017-CA (4 dBi)	Duty Cycle (%)	100
Test Notes 1	NIC 411-3G-070B;		
Test Notes 2	4VDC		

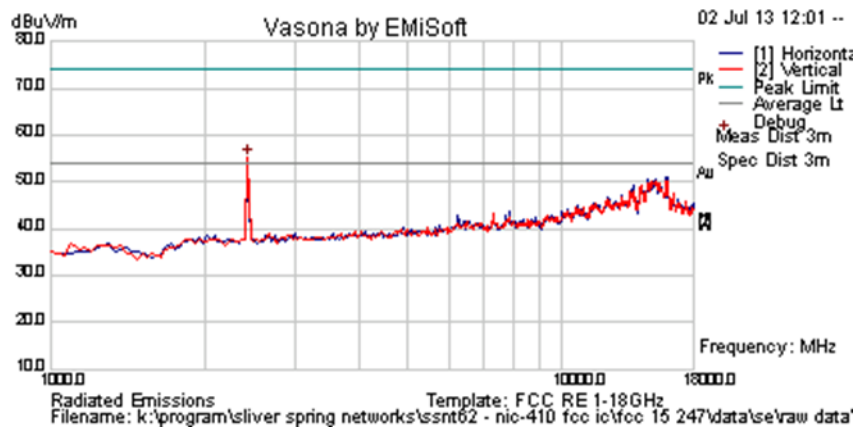

Formally measured emission peaks

Frequency MHz	Raw dBuV	Cable Loss	AF dB	Level dBuV/m	Measurement Type	Pol	Hgt cm	Azt Deg	Limit dBuV/m	Margin dB	Pass /Fail	Comments
2430.862	63.6	3.2	-11.6	55.2	Peak [Scan]	V	100					FUND

Legend: TX = Transmitter Emissions; DIG = Digital Emissions; FUND = Fundamental; WB = Wideband Emission
 RB = Restricted Band (15.209 Limits); NRB = Non Restricted Band, Limit is 20dB below fundamental peak

This test report may be reproduced in full only. The document may only be updated by MiCOM Labs personnel. Any changes will be noted in the Document History section of the report.



Title: Silver Spring Network MicroAP
To: FCC 47 CFR Part15.247 & IC RSS-210
Serial #: SSNT62-U2 Rev A
Issue Date: 13th August 2013
Page: 85 of 147

Test Freq.	2472.8 MHz;	Engineer	SB
Variant	Cont TX (GFSK 500 kbps)	Temp (°C)	29
Freq. Range	1000 MHz - 18000 MHz	Rel. Hum.(%)	30
Power Setting	ATS112=15	Press. (mBars)	997
Antenna	WP WPANT 30017-CA (4 dBi)	Duty Cycle (%)	100
Test Notes 1	NIC 411-3G-070B;		
Test Notes 2	4VDC		

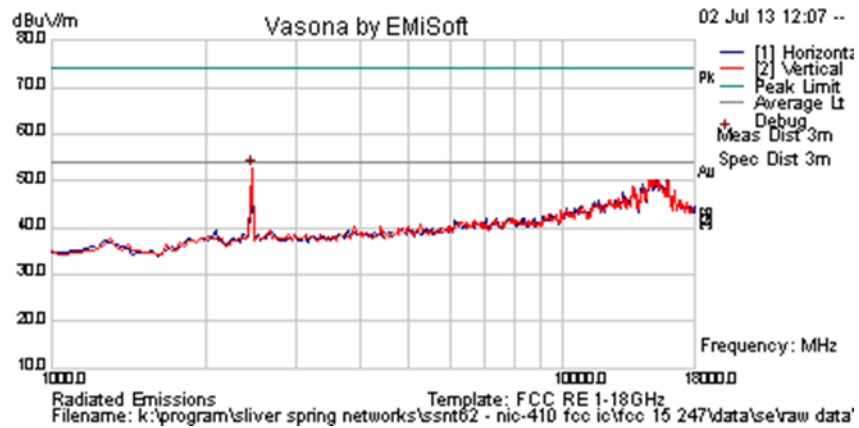

Formally measured emission peaks

Frequency MHz	Raw dBuV	Cable Loss	AF dB	Level dBuV/m	Measurement Type	Pol	Hgt cm	Azt Deg	Limit dBuV/m	Margin dB	Pass /Fail	Comments
2464.930	61.0	3.2	-11.5	52.7	Peak [Scan]	V	100					FUND

Legend: TX = Transmitter Emissions; DIG = Digital Emissions; FUND = Fundamental; WB = Wideband Emission
 RB = Restricted Band (15.209 Limits); NRB = Non Restricted Band, Limit is 20dB below fundamental peak

This test report may be reproduced in full only. The document may only be updated by MiCOM Labs personnel. Any changes will be noted in the Document History section of the report.



6.1.5.6. 2.4 GHz External Antenna Radiated Band-Edge

External Antenna

Operational Mode	2390 MHz			2483.5 MHz		
	dB μ V		Power Setting	dB μ V		Power Setting
	Peak	Average		Peak	Average	
DSSS	61.45	52.81	15	58.81	51.71	4
250 kBit/s	48.16	35.52	15	45.19	32.18	15
500 kBit/s	52.28	43.11	15	52.39	41.65	15

This test report may be reproduced in full only. The document may only be updated by MiCOM Labs personnel. Any changes will be noted in the Document History section of the report.



Title: Silver Spring Network MicroAP
To: FCC 47 CFR Part15.247 & IC RSS-210
Serial #: SSNT62-U2 Rev A
Issue Date: 13th August 2013
Page: 87 of 147

Specification

Limits

FCC Part 15 Subpart C §15.247(d)

Industry Canada §A8.5

In any 100 kHz bandwidth outside the frequency band in which the spread spectrum or digitally modulated intentional radiator is operating, the radio frequency power that is produced by the intentional radiator shall be at least 20 dB below that in the 100 kHz bandwidth within the band that contains the highest level of the desired power, based on either an RF conducted or a radiated measurement, provided the transmitter demonstrates compliance with the peak conducted power limits.

Laboratory Measurement Uncertainty for Radiated Emissions

Measurement uncertainty	+5.6/ -4.5 dB
-------------------------	---------------

Traceability

Method	Test Equipment Used
Measurements were made per work instruction WI-03 'Measurement of Radiated Emissions'	0287, 0335, 0338, 0158, 0134, 0304, 0311, 0315, 0310, 0312

This test report may be reproduced in full only. The document may only be updated by MiCOM Labs personnel. Any changes will be noted in the Document History section of the report.

6.1.6. Radiated Spurious Emissions – Digital Emissions (0.03-1 GHz)

FCC, Part 15 Subpart C §15.247(d), §15.205, 15.209
Industry Canada RSS-Gen §6.1

Test Procedure

Preliminary radiated emissions were measured in the anechoic chamber at a 3-meter distance on every azimuth in both horizontal and vertical polarity. The emissions are recorded with a CISPR compliant spectrum analyzer in peak hold mode. Emissions closest to the limits are measured in the quasi-peak mode with the tuned receiver using a bandwidth of 120 kHz. Only the highest emissions relative to the limit are listed. A photograph of the test set-up in the anechoic chamber in Section 6 Test Set-Up Photographs.

A notch filter with >70 dB of rejection was used to remove the fundamental frequency.

Test Measurement Set up

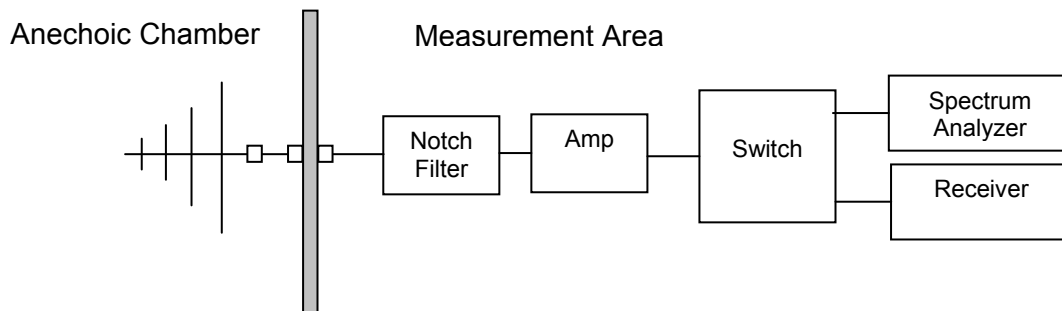

Field Strength Calculation

The field strength is calculated by adding the Antenna Factor and Cable Loss, and subtracting Amplifier Gain from the measured reading. In this test facility, the Antenna Factor, Cable Loss, and Amplifier Gains are loaded into the Rohde & Schwarz Receiver and the corrected field strength can be read directly on the receiver.

$$FS = R + AF + CORR$$

where:

FS = Field Strength
R = Measured Receiver Input Amplitude
AF = Antenna Factor
CORR = Correction Factor = CL – AG + NFL
CL = Cable Loss
AG = Amplifier Gain



Title: Silver Spring Network MicroAP
To: FCC 47 CFR Part15.247 & IC RSS-210
Serial #: SSNT62-U2 Rev A
Issue Date: 13th August 2013
Page: 89 of 147

For example:

Given a Receiver input reading of 51.5dB μ V; Antenna Factor of 8.5dB; Cable Loss of 1.3dB; Falloff Factor of 0dB, an Amplifier Gain of 26dB and Notch Filter Loss of 1dB. The Field Strength of the measured emission is:

$$FS = 51.5 + 8.5 + 1.3 - 26.0 + 1 = 36.3\text{dB}\mu\text{V/m}$$

Conversion between dB μ V/m (or dB μ V) and μ V/m (or μ V) are done as:

$$\text{Level (dB}\mu\text{V/m)} = 20 * \text{Log (level (\mu\text{V/m}))}$$

$$40 \text{ dB}\mu\text{V/m} = 100\mu\text{V/m}$$

$$48 \text{ dB}\mu\text{V/m} = 250\mu\text{V/m}$$

This test report may be reproduced in full only. The document may only be updated by MiCOM Labs personnel. Any changes will be noted in the Document History section of the report.



Title: Silver Spring Network MicroAP
To: FCC 47 CFR Part15.247 & IC RSS-210
Serial #: SSNT62-U2 Rev A
Issue Date: 13th August 2013
Page: 90 of 147

6.1.6.1. Radiated Digital Emissions

Test Freq.	915.2 MHz;	Engineer	SB
Variant	Digital Emissions	Temp (°C)	29
Freq. Range	30 MHz - 1000 MHz	Rel. Hum.(%)	30
Power Setting	ATS112=15	Press. (mBars)	997
Antenna	Integral	Duty Cycle (%)	100
Test Notes 1	NIC 411-3G-070B;		
Test Notes 2	4VDC		

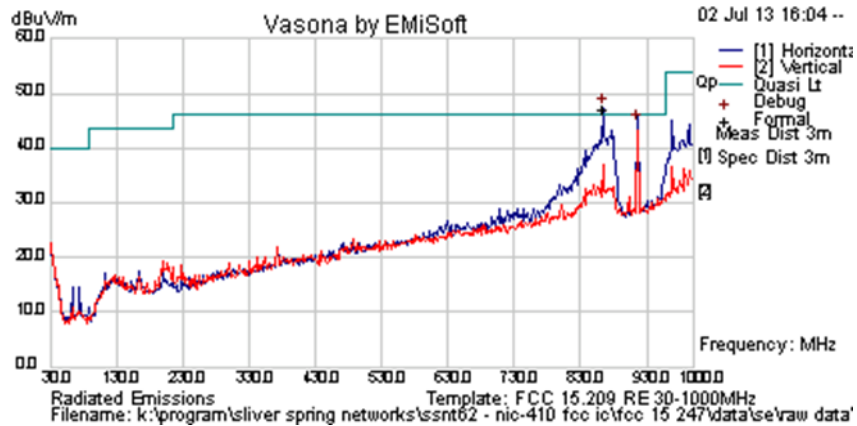

Formally measured emission peaks

Frequency MHz	Raw dBuV	Cable Loss	AF dB	Level dBuV/m	Measurement Type	Pol	Hgt cm	Azt Deg	Limit dBuV/m	Margin dB	Pass /Fail	Comments
863.144	48.6	7.0	-8.2	47.4	Peak [Scan]	H	100					NRB
916.586	45.0	7.2	-7.7	44.5	Peak [Scan]	H	98	360	46	-1.6	Pass	FUND

Legend: DIG = Digital Device Emission; TX = Transmitter Emission; FUND = Fundamental Frequency
 NRB = Non-Restricted Band, Limit is 20 dB below Fundamental; RB = Restricted Band

This test report may be reproduced in full only. The document may only be updated by MiCOM Labs personnel. Any changes will be noted in the Document History section of the report.



Specification

Limits

§15.205 (a) Except as shown in paragraph (d) of 15.205 (a), only spurious emissions are permitted in any of the frequency bands listed.

§15.205 (a) Except as shown in paragraphs (d) and (e) of this section, the field strength of emissions appearing within these frequency bands shall not exceed the limits shown in Section §15.209. At frequencies equal to or less than 1000 MHz, compliance with the limits in Section 15.209 shall be demonstrated using measurement instrumentation employing a CISPR quasi-peak detector. Above 1000 MHz, compliance with the emission limits in Section 15.209 shall be demonstrated based on the average value of the measured emissions. The provisions in Section 15.35 apply to these measurements.

§15.209 (a) Except as provided elsewhere in this subpart, the emissions from an intentional radiator shall not exceed the field strength levels specified in the following table.

§15.209 (a) and RSS-Gen §6.1 Limit Matrix

Frequency(MHz)	Field Strength (µV/m)	Field Strength (dBµV/m)	Measurement Distance (meters)
30-88	100	40.0	3
88-216	150	43.5	3
216-960	200	46.0	3
Above 960	500	54.0	3

Laboratory Measurement Uncertainty for Radiated Emissions

Measurement uncertainty	+5.6/ -4.5 dB
-------------------------	---------------

Traceability

Method	Test Equipment Used
Measurements were made per work instruction WI-03 'Measurement of Radiated Emissions'	0287, 0335, 0338, 0158, 0134, 0304, 0311, 0315, 0310, 0312, 0341

This test report may be reproduced in full only. The document may only be updated by MiCOM Labs personnel. Any changes will be noted in the Document History section of the report.

6.1.7. AC Wireline Conducted Emissions (150 kHz – 30 MHz)

NOTE: Test not applicable EUT was dc powered

FCC, Part 15 Subpart C §15.207
Industry Canada RSS-Gen §7.2.4

Test Procedure

The EUT is configured in accordance with ANSI C63.4. The conducted emissions are measured in a shielded room with a spectrum analyzer in peak hold in the first instance. Emissions closest to the limit are measured in the quasi-peak mode (QP) with the tuned receiver using a bandwidth of 9 kHz. The emissions are maximized further by cable manipulation. The highest emissions relative to the limit are listed.

Test Measurement Set up

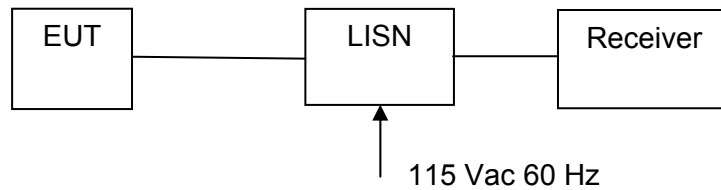

Measurement set up for AC Wireline Conducted Emissions Test

Measurement Results for AC Wireline Conducted Emissions (150 kHz – 30 MHz)



Specification

Limit

§15.207 (a) Except as shown in paragraphs (b) and (c) of this section, for an intentional radiator that is designed to be connected to the public utility (AC) power line, the radio frequency voltage that is conducted back onto the AC power line on any frequency or frequencies within the band 150 kHz to 30 MHz shall not exceed the limits in the following table, as measured using a 50 $\mu\Omega$ line impedance stabilization network (LISN), see §15.207 (a) matrix below. Compliance with the provisions of this paragraph shall be based on the measurement of the radio frequency voltage between each power line and ground at the power terminal.

RSS-Gen §7.2.4

The radio frequency voltage that is conducted back into the AC power lines in the frequency range of 0.15 MHz to 30 MHz shall not exceed the limits shown in the table below. The tighter limit applies at the frequency range boundaries.

§15.207 (a) and **RSS-Gen §7.2.2** Limit Matrix

The lower limit applies at the boundary between frequency ranges

Frequency of Emission (MHz)	Conducted Limit (dB μ V)	
	Quasi-peak	Average
0.15-0.5	66 to 56*	56 to 46*
0.5-5	56	46
5-30	60	50

* Decreases with the logarithm of the frequency

Laboratory Measurement Uncertainty for Conducted Emissions

Measurement uncertainty	± 2.64 dB
-------------------------	---------------

Traceability

Method	Test Equipment Used
Measurements were made per Sanmina work instruction	0190, 0193

This test report may be reproduced in full only. The document may only be updated by MiCOM Labs personnel. Any changes will be noted in the Document History section of the report.

7. PHOTOGRAPHS

7.1. General Measurement Test Set-Up

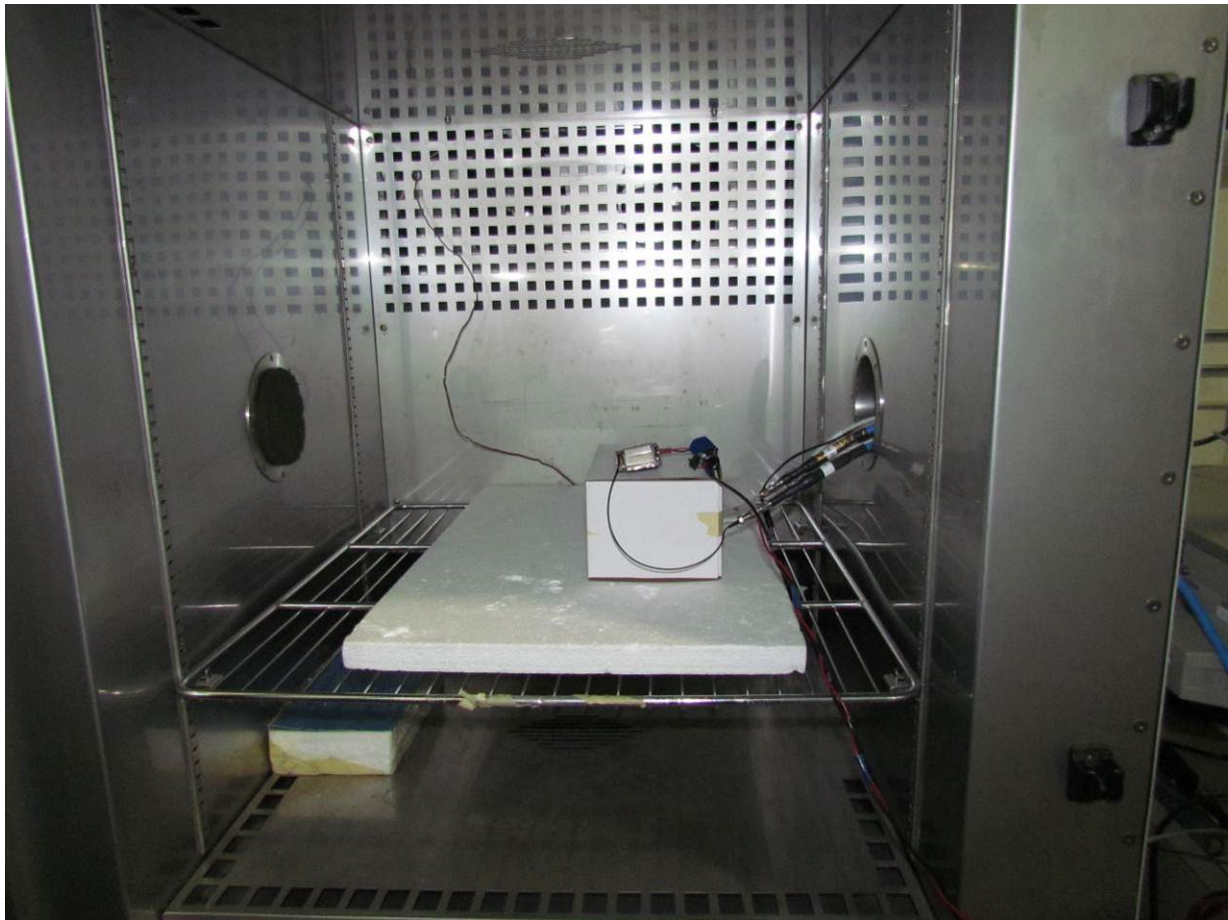

This test report may be reproduced in full only. The document may only be updated by MiCOM Labs personnel. Any changes will be noted in the Document History section of the report.

7.2. Radiated Emissions <1 GHz

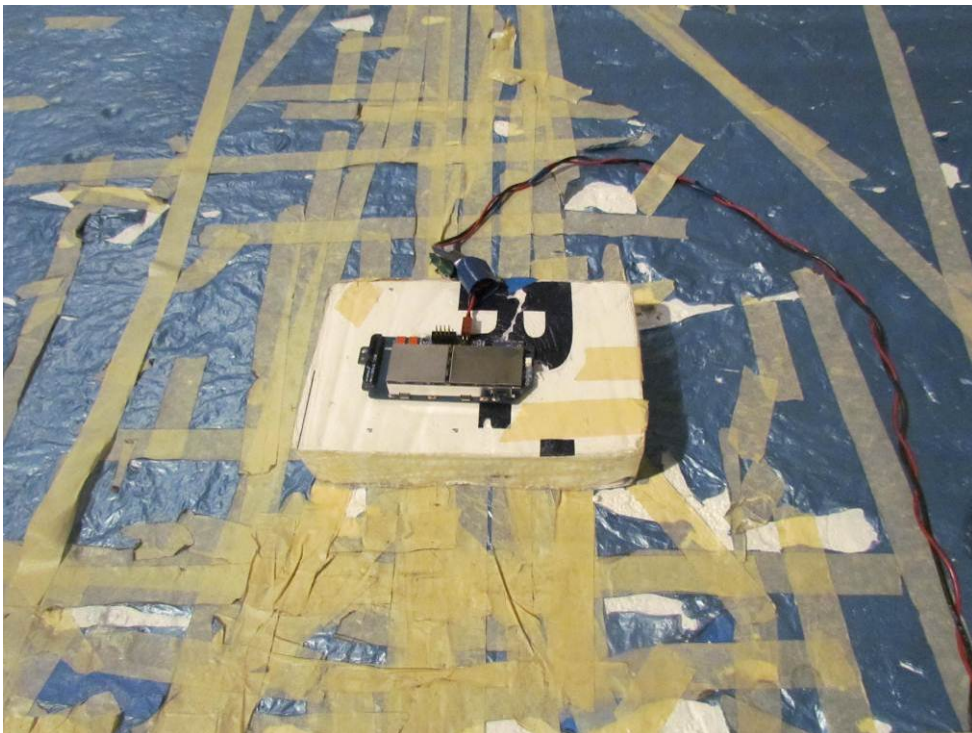
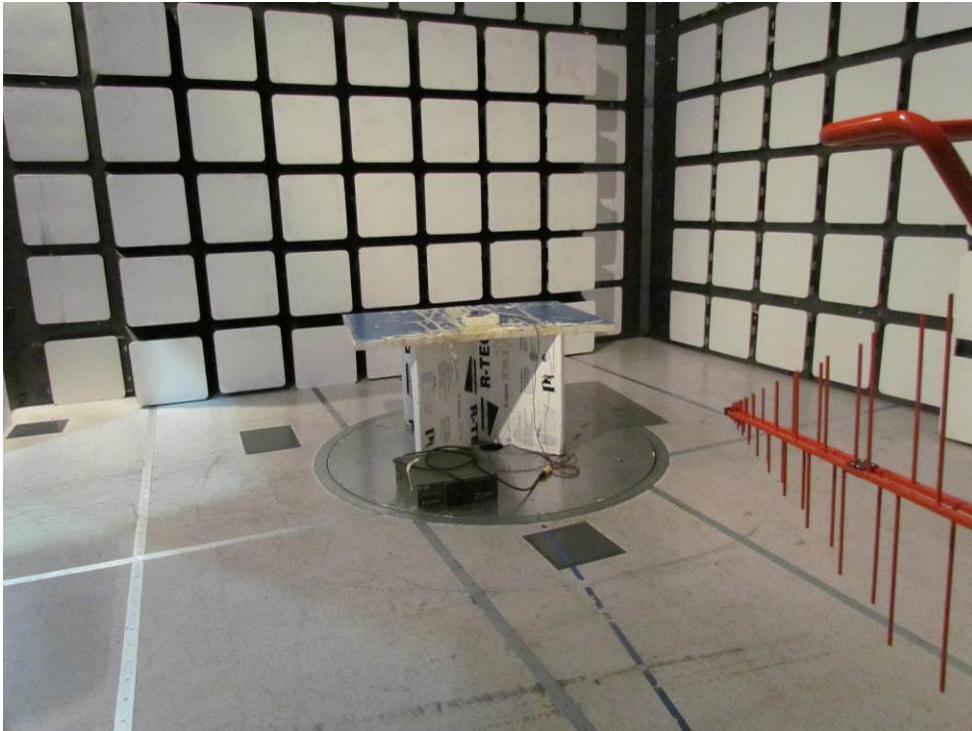

This test report may be reproduced in full only. The document may only be updated by MiCOM Labs personnel. Any changes will be noted in the Document History section of the report.

7.3. Radiated Emissions >1 GHz

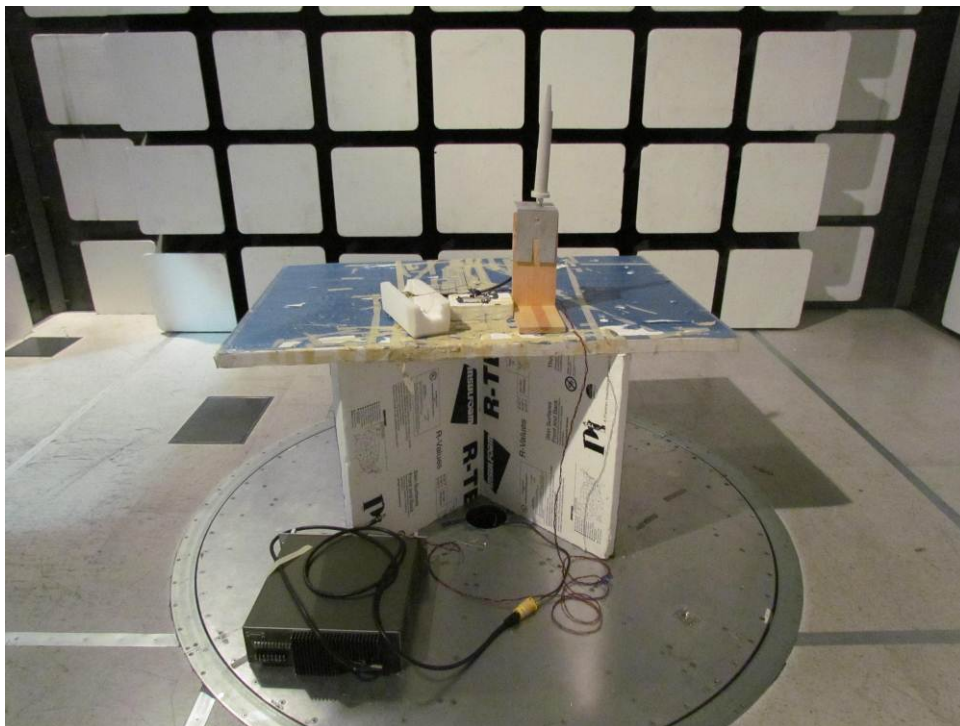
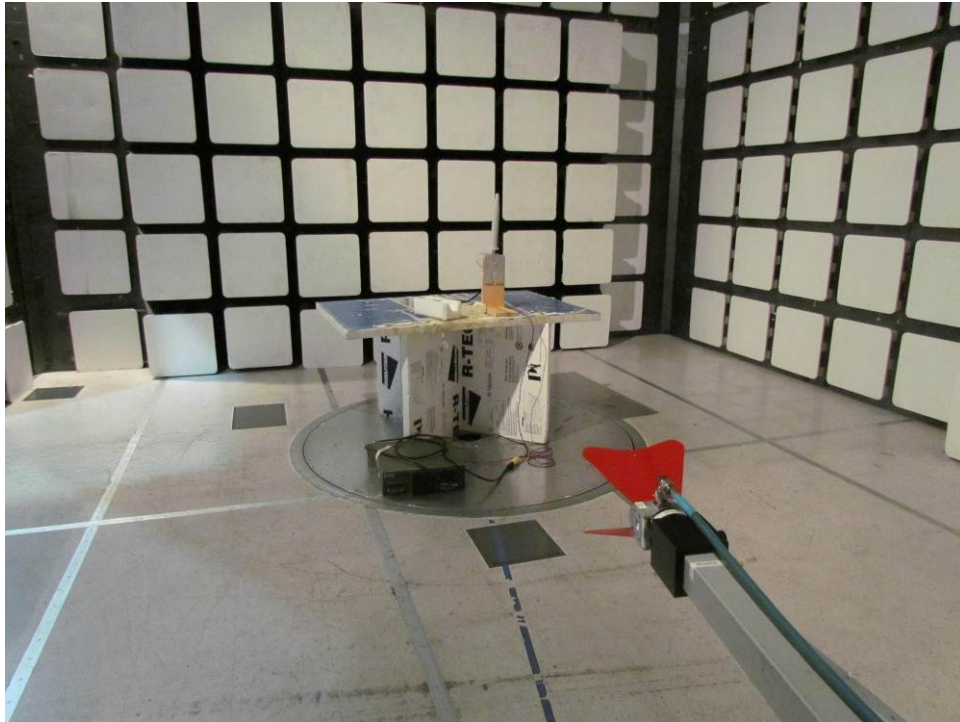

This test report may be reproduced in full only. The document may only be updated by MiCOM Labs personnel. Any changes will be noted in the Document History section of the report.



Title: Silver Spring Network MicroAP
To: FCC 47 CFR Part15.247 & IC RSS-210
Serial #: SSNT62-U2 Rev A
Issue Date: 13th August 2013
Page: 97 of 147

8. TEST EQUIPMENT DETAILS

Asset #	Instrument	Manufacturer	Part #	Serial #	Calibration Due Date
0070	Power Meter	Hewlett Packard	437B	3125U11552	28 th Nov 13
0117	Power Sensor	Hewlett Packard	8487D	3318A00371	15 th Nov 13
0223	Power Meter	Hewlett Packard	EPM-442A	US37480256	15 th Nov 13
0374	Power Sensor	Hewlett Packard	8485A	3318A19694	29 th Nov 13
0376	Power Sensor	Agilent	U2000A	MY51440005	8 th Dec 13
0158	Barometer /Thermometer	Control Co.	4196	E2846	8 th Dec 13
0193	EMI Receiver	Rhode & Schwartz	ESI 7	838496/007	2 nd Dec 13
0287	EMI Receiver	Rhode & Schwartz	ESIB40	100201	16 th Nov 13
0338	30 - 3000 MHz Antenna	Sunol	JB3	A052907	8 th Nov 13
0335	1-18 GHz Horn Antenna	EMCO	3117	00066580	7 th Nov 13
0252	SMA Cable	Megaphase	Sucoflex 104	None	N/A
0293	BNC Cable	Megaphase	1689 1GVT4	15F50B001	N/A
0307	BNC Cable	Megaphase	1689 1GVT4	15F50B002	N/A
0310	2m SMA Cable	Micro-Coax	UFA210A-0-0787-3G03G0	209089-001	N/A
0312	3m SMA Cable	Micro-Coax	UFA210A-1-1181-3G0300	209092-001	N/A
0314	30dB N-Type Attenuator	ARRA	N9444-30	1623	N/A
	EMC Test Software	EMISoft	Vasona	5.0051	N/A
	RF Conducted Test Software	National Instruments	Labview	Version 8.2	N/A
	RF Conducted Test Software	MiCOM Labs ATS		Version 1.5	N/A

This test report may be reproduced in full only. The document may only be updated by MiCOM Labs personnel. Any changes will be noted in the Document History section of the report.



Title: Silver Spring Network MicroAP
To: FCC 47 CFR Part15.247 & IC RSS-210
Serial #: SSNT62-U2 Rev A
Issue Date: 13th August 2013
Page: 98 of 147

APPENDIX

A. SUPPORTING INFORMATION

A.1. CONDUCTED TEST PLOTS

This test report may be reproduced in full only. The document may only be updated by MiCOM Labs personnel. Any changes will be noted in the Document History section of the report.



A.1.1. 20 dB & 99% Bandwidth



20 dB & 99% BANDWIDTH

Variant: FHSS, Channel: 902.30 MHz, Chain a, Temp: Ambient, Voltage: 4 Vdc

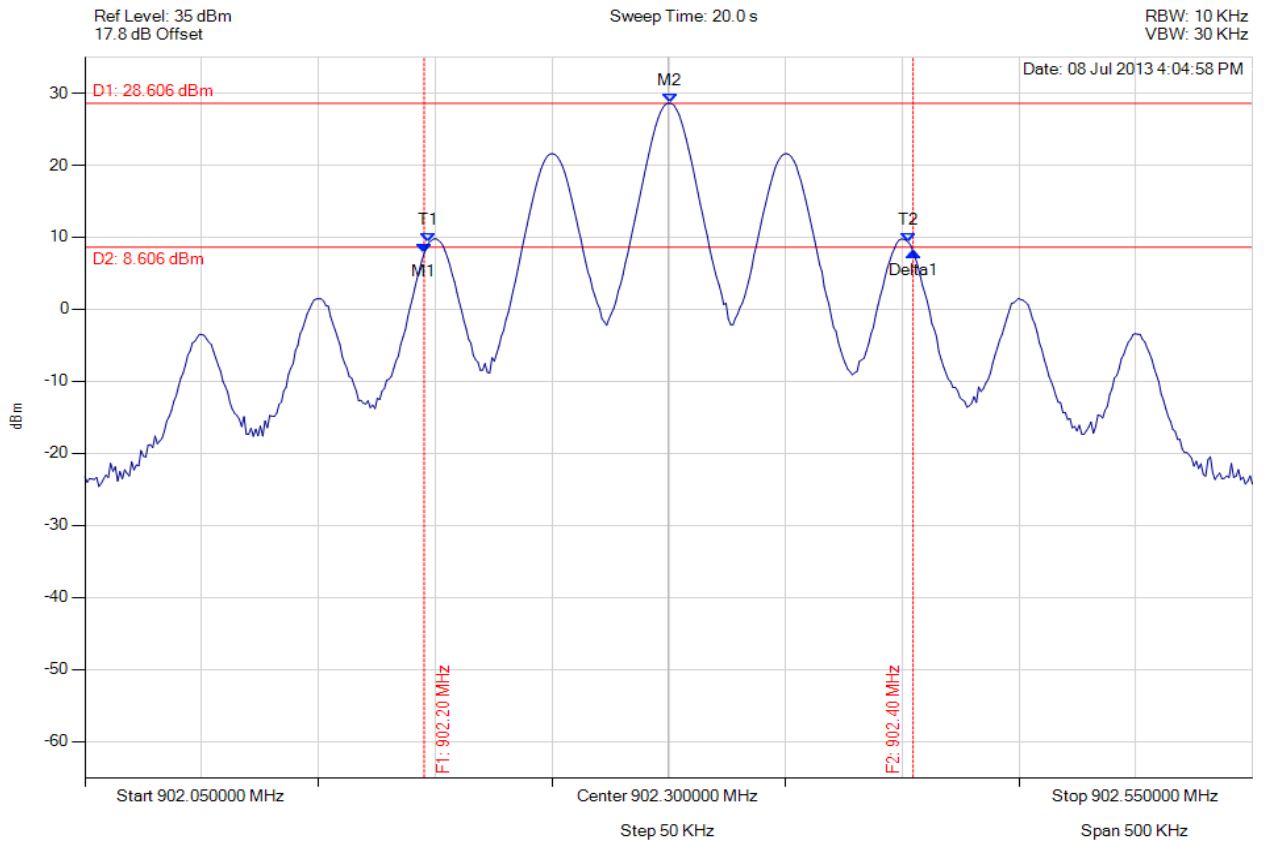

Analyser Setup	Marker : Frequency : Amplitude	Test Results
Detector = MAX PEAK Sweep Count = 0 RF Atten (dB) = 30 Trace Mode = VIEW	M1 : 902.195 MHz : 7.750 dBm M2 : 902.301 MHz : 28.606 dBm Delta1 : 209 KHz : 0.218 dB T1 : 902.197 MHz : 9.239 dBm T2 : 902.403 MHz : 9.251 dBm OBW : 205 KHz	Measured 20 dB Bandwidth: 0.209 MHz Limit: ≤250.0 kHz Margin: -41.0 kHz

[Back to the Matrix](#)

This test report may be reproduced in full only. The document may only be updated by MiCOM Labs personnel. Any changes will be noted in the Document History section of the report.



20 dB & 99% BANDWIDTH

Variant: FHSS, Channel: 915.20 MHz, Chain a, Temp: Ambient, Voltage: 4 Vdc

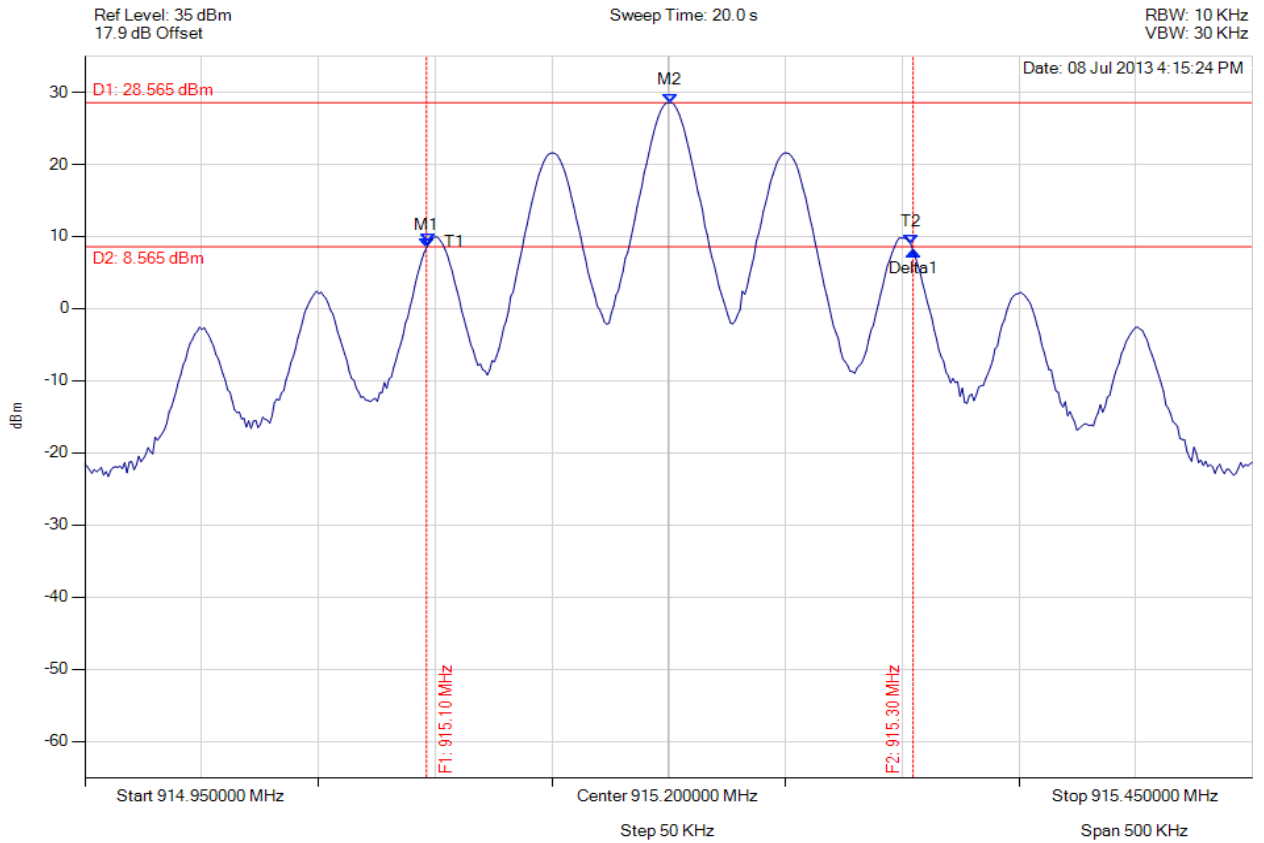

Analyser Setup	Marker : Frequency : Amplitude	Test Results
Detector = MAX PEAK Sweep Count = 0 RF Atten (dB) = 30 Trace Mode = VIEW	M1 : 915.096 MHz : 8.472 dBm M2 : 915.201 MHz : 28.565 dBm Delta1 : 208 KHz : -0.466 dB T1 : 915.097 MHz : 9.212 dBm T2 : 915.304 MHz : 8.968 dBm OBW : 206 KHz	Measured 20 dB Bandwidth: 0.208 MHz Limit: ≤250.0 kHz Margin: -42.0 kHz

[Back to the Matrix](#)

This test report may be reproduced in full only. The document may only be updated by MiCOM Labs personnel. Any changes will be noted in the Document History section of the report.



20 dB & 99% BANDWIDTH

Variant: FHSS, Channel: 927.50 MHz, Chain a, Temp: Ambient, Voltage: 4 Vdc

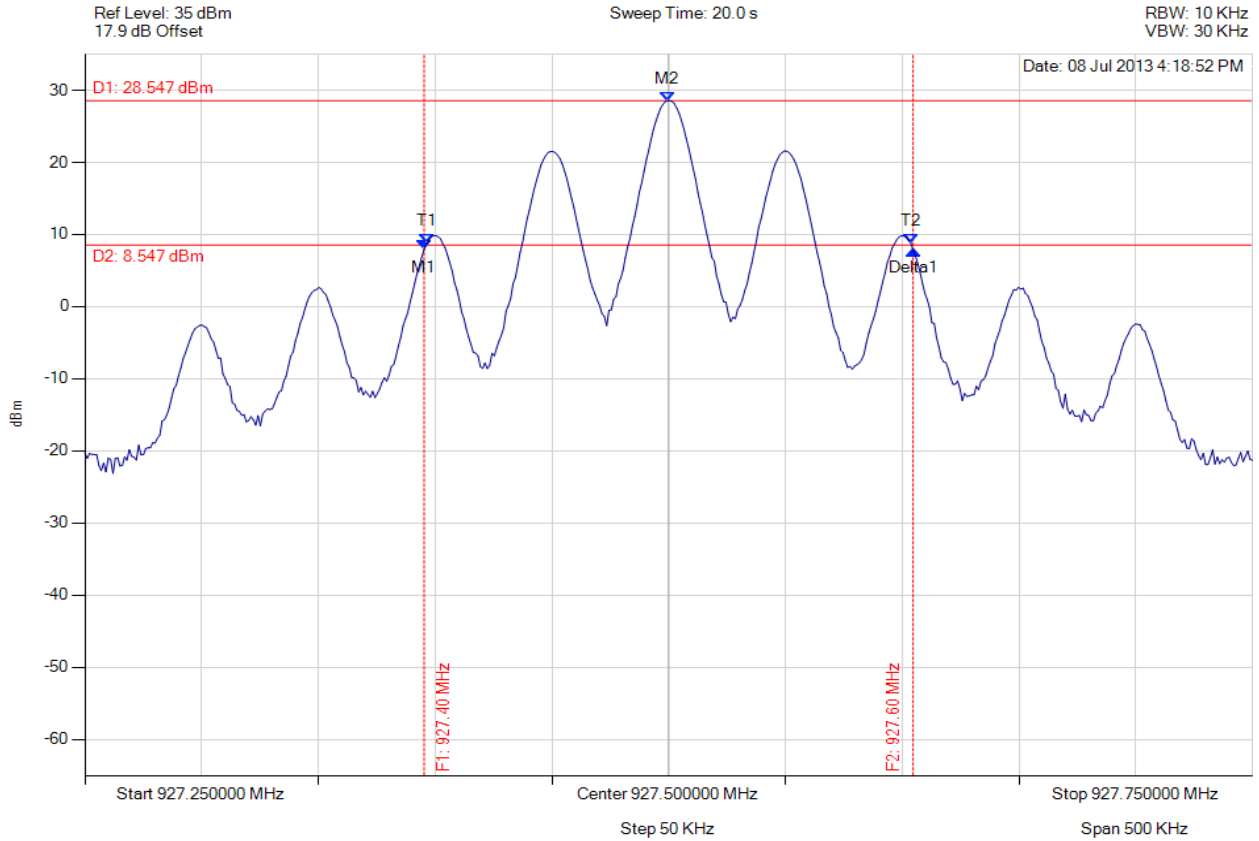

Analyser Setup	Marker : Frequency : Amplitude	Test Results
Detector = MAX PEAK Sweep Count = 0 RF Atten (dB) = 30 Trace Mode = VIEW	M1 : 927.395 MHz : 7.929 dBm M2 : 927.499 MHz : 28.547 dBm Delta1 : 209 KHz : -0.102 dB T1 : 927.396 MHz : 8.779 dBm T2 : 927.604 MHz : 8.830 dBm OBW : 207 KHz	Measured 6 dB Bandwidth : 0.209 MHz Limit: ≤250.0 kHz Margin: -41.0 kHz

[Back to the Matrix](#)

This test report may be reproduced in full only. The document may only be updated by MiCOM Labs personnel. Any changes will be noted in the Document History section of the report.



Title: Silver Spring Network MicroAP
To: FCC 47 CFR Part15.247 & IC RSS-210
Serial #: SSNT62-U2 Rev A
Issue Date: 13th August 2013
Page: 102 of 147



20 dB & 99% BANDWIDTH

Variant: FHSS, Channel: 902.20 MHz, Chain a, Temp: Ambient, Voltage: 4 Vdc

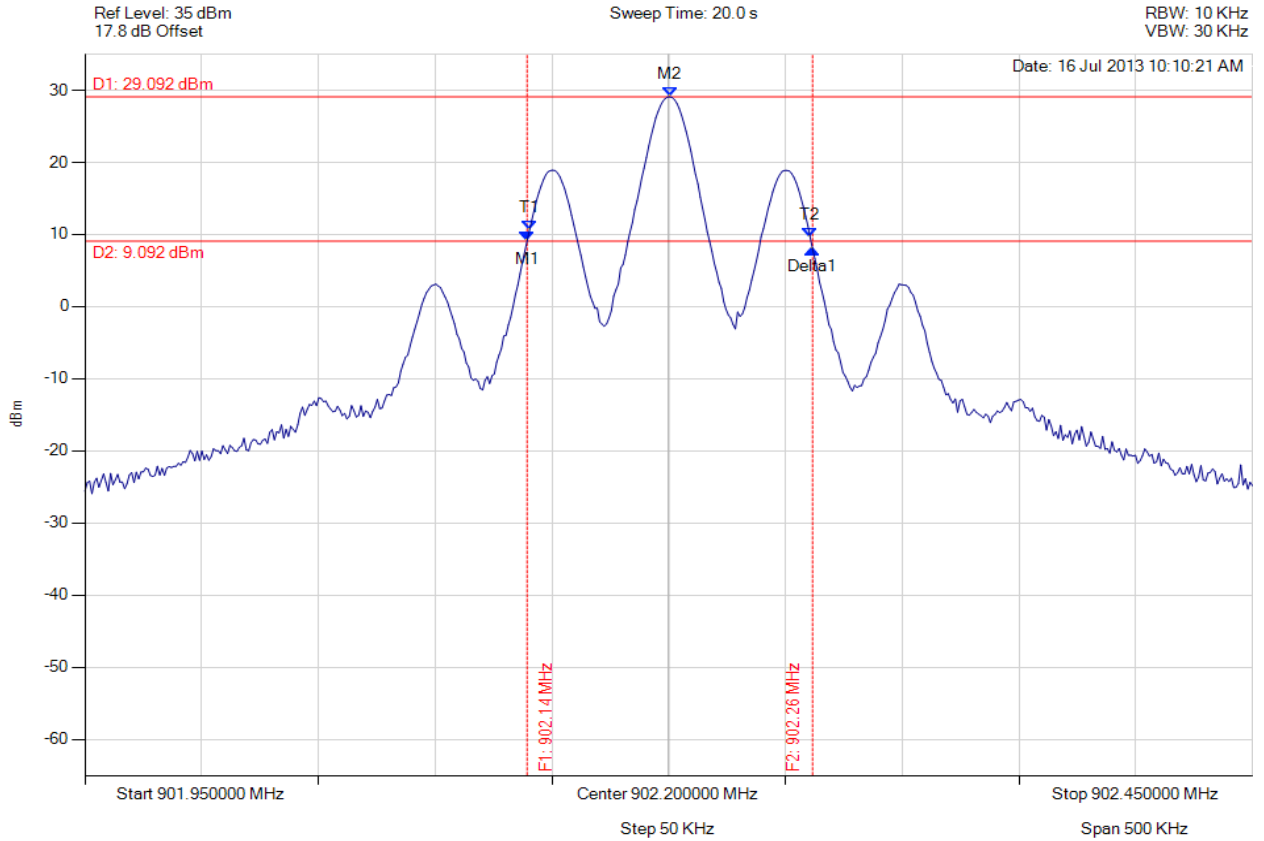

Analyser Setup	Marker : Frequency : Amplitude	Test Results
Detector = MAX PEAK Sweep Count = 0 RF Atten (dB) = 30 Trace Mode = VIEW	M1 : 902.139 MHz : 9.086 dBm M2 : 902.201 MHz : 29.092 dBm Delta1 : 122 KHz : -1.092 dB T1 : 902.140 MHz : 10.583 dBm T2 : 902.261 MHz : 9.572 dBm OBW : 120 KHz	Measured 20 dB Bandwidth: 0.122 MHz Limit: ≤250.0 kHz Margin: -128.0 kHz

[Back to the Matrix](#)

This test report may be reproduced in full only. The document may only be updated by MiCOM Labs personnel. Any changes will be noted in the Document History section of the report.



20 dB & 99% BANDWIDTH

Variant: FHSS, Channel: 915.00 MHz, Chain a, Temp: Ambient, Voltage: 4 Vdc

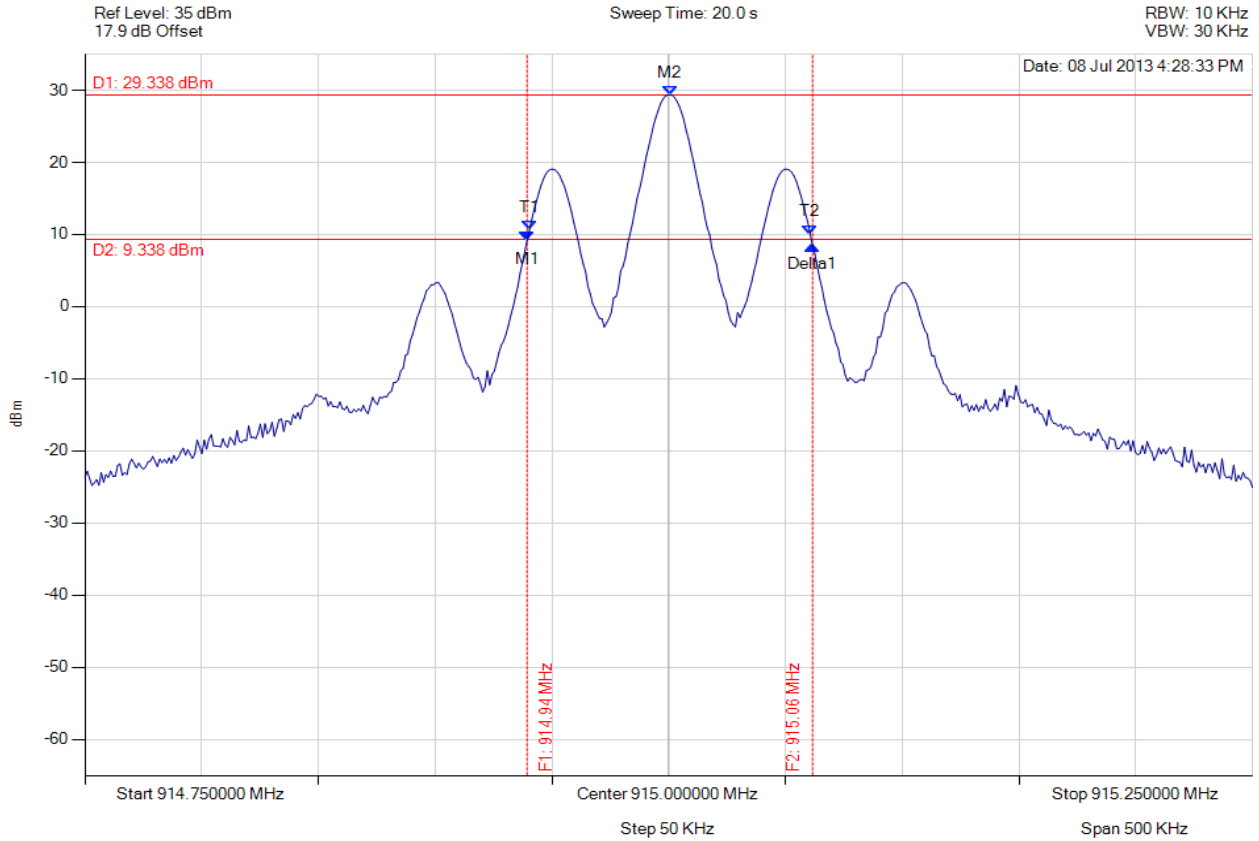

Analyser Setup	Marker : Frequency : Amplitude	Test Results
Detector = MAX PEAK Sweep Count = 0 RF Atten (dB) = 30 Trace Mode = VIEW	M1 : 914.939 MHz : 9.145 dBm M2 : 915.001 MHz : 29.338 dBm Delta1 : 122 KHz : -0.718 dB T1 : 914.940 MHz : 10.615 dBm T2 : 915.061 MHz : 10.042 dBm OBW : 120 KHz	Measured 20 dB Bandwidth: 0.122 MHz Limit: ≤250.0 kHz Margin: -128.0 kHz

[Back to the Matrix](#)

This test report may be reproduced in full only. The document may only be updated by MiCOM Labs personnel. Any changes will be noted in the Document History section of the report.



Title: Silver Spring Network MicroAP
To: FCC 47 CFR Part15.247 & IC RSS-210
Serial #: SSNT62-U2 Rev A
Issue Date: 13th August 2013
Page: 104 of 147



20 dB & 99% BANDWIDTH

Variant: FHSS, Channel: 927.80 MHz, Chain a, Temp: Ambient, Voltage: 4 Vdc

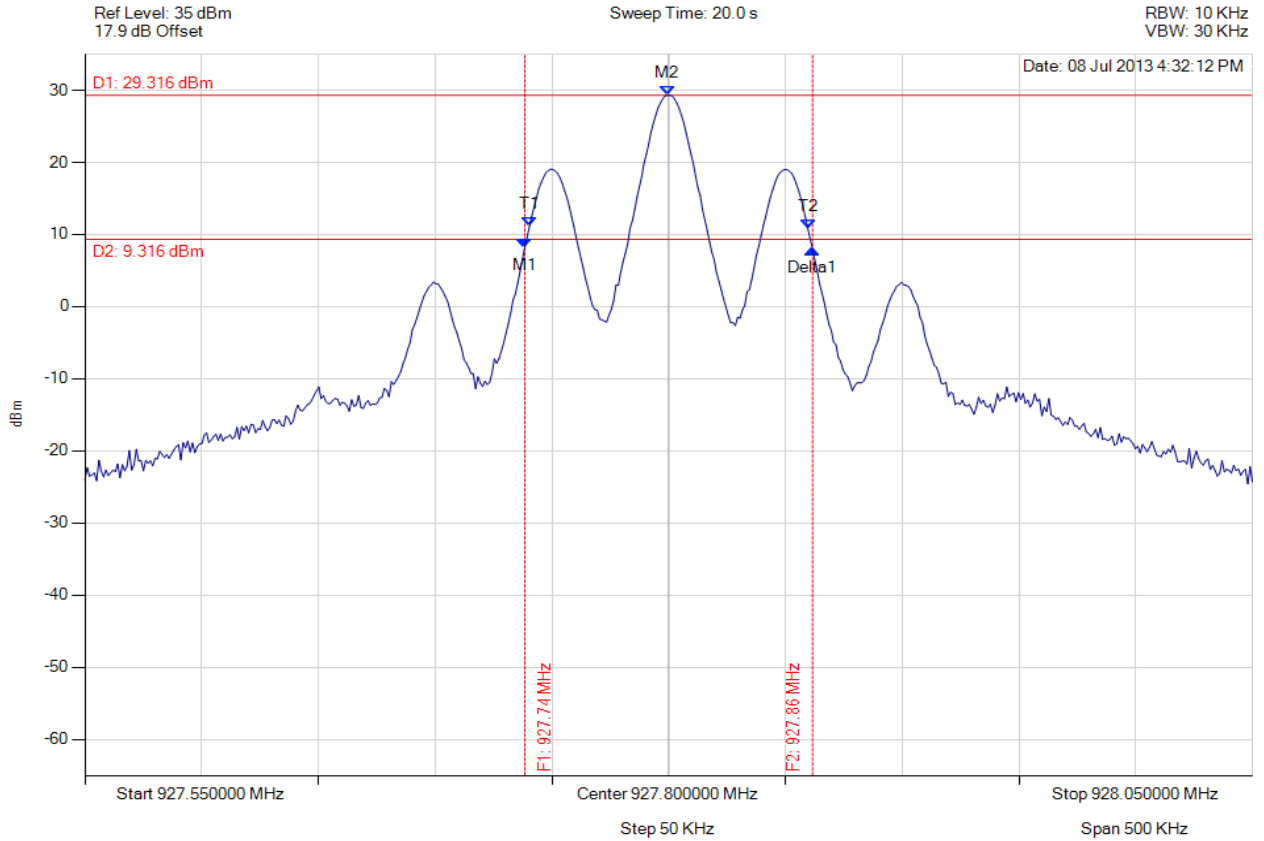

Analyser Setup	Marker : Frequency : Amplitude	Test Results
Detector = MAX PEAK Sweep Count = 0 RF Atten (dB) = 30 Trace Mode = VIEW	M1 : 927.738 MHz : 8.218 dBm M2 : 927.799 MHz : 29.316 dBm Delta1 : 123 KHz : -0.248 dB T1 : 927.740 MHz : 11.114 dBm T2 : 927.860 MHz : 10.831 dBm OBW : 119 KHz	Measured 20 dB Bandwidth: 0.123 MHz Limit: ≤250.0 kHz Margin: -128.0 kHz

[Back to the Matrix](#)

This test report may be reproduced in full only. The document may only be updated by MiCOM Labs personnel. Any changes will be noted in the Document History section of the report.



20 dB & 99% BANDWIDTH

Variant: FHSS, Channel: 902.30 MHz, Chain a, Temp: Ambient, Voltage: 4 Vdc

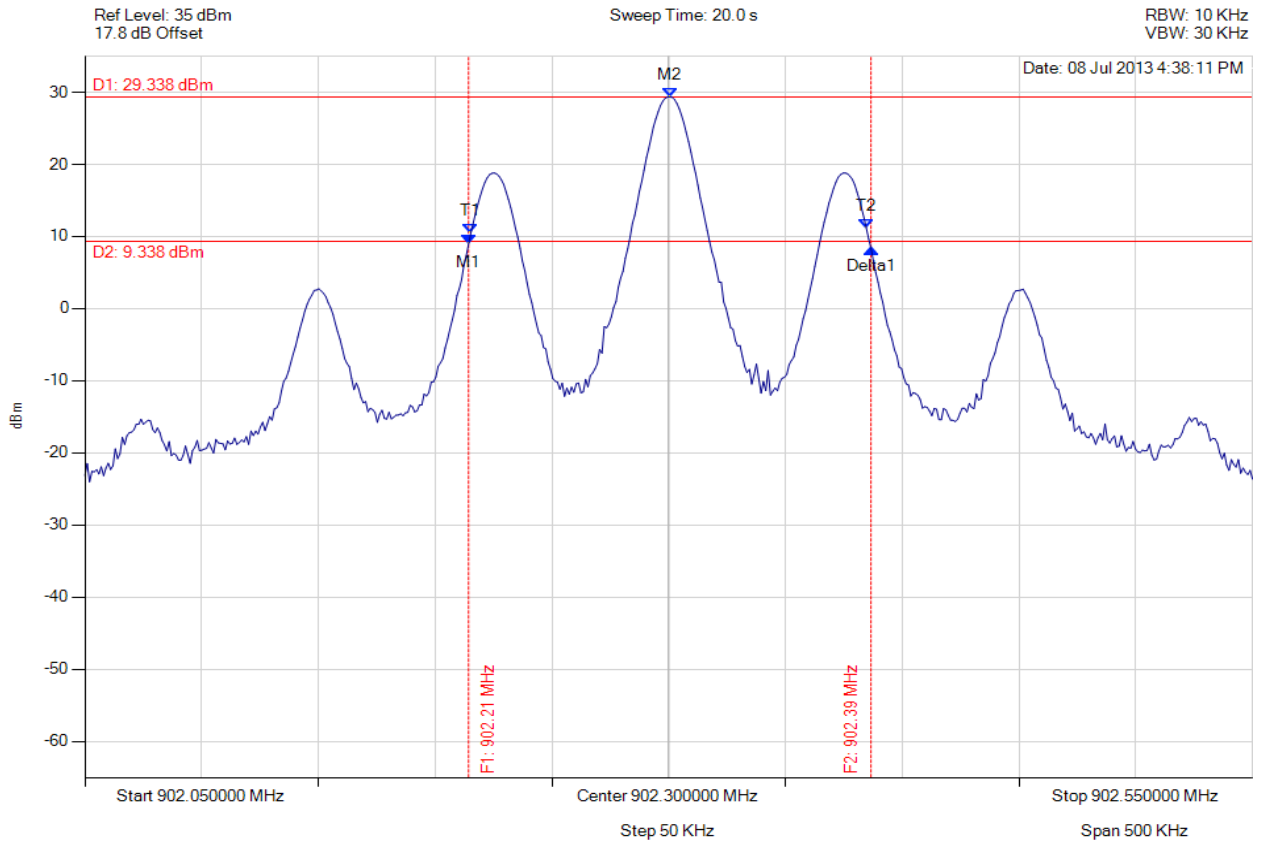

Analyser Setup	Marker : Frequency : Amplitude	Test Results
Detector = MAX PEAK Sweep Count = 0 RF Atten (dB) = 30 Trace Mode = VIEW	M1 : 902.214 MHz : 8.980 dBm M2 : 902.301 MHz : 29.338 dBm Delta1 : 172 KHz : -0.643 dB T1 : 902.215 MHz : 10.532 dBm T2 : 902.385 MHz : 11.122 dBm OBW : 169 KHz	Measured 20 dB Bandwidth: 0.172 MHz Limit: ≤250.0 kHz Margin: -78.0 kHz

[Back to the Matrix](#)

This test report may be reproduced in full only. The document may only be updated by MiCOM Labs personnel. Any changes will be noted in the Document History section of the report.



Title: Silver Spring Network MicroAP
To: FCC 47 CFR Part15.247 & IC RSS-210
Serial #: SSNT62-U2 Rev A
Issue Date: 13th August 2013
Page: 106 of 147



20 dB & 99% BANDWIDTH

Variant: FHSS, Channel: 915.20 MHz, Chain a, Temp: Ambient, Voltage: 4 Vdc

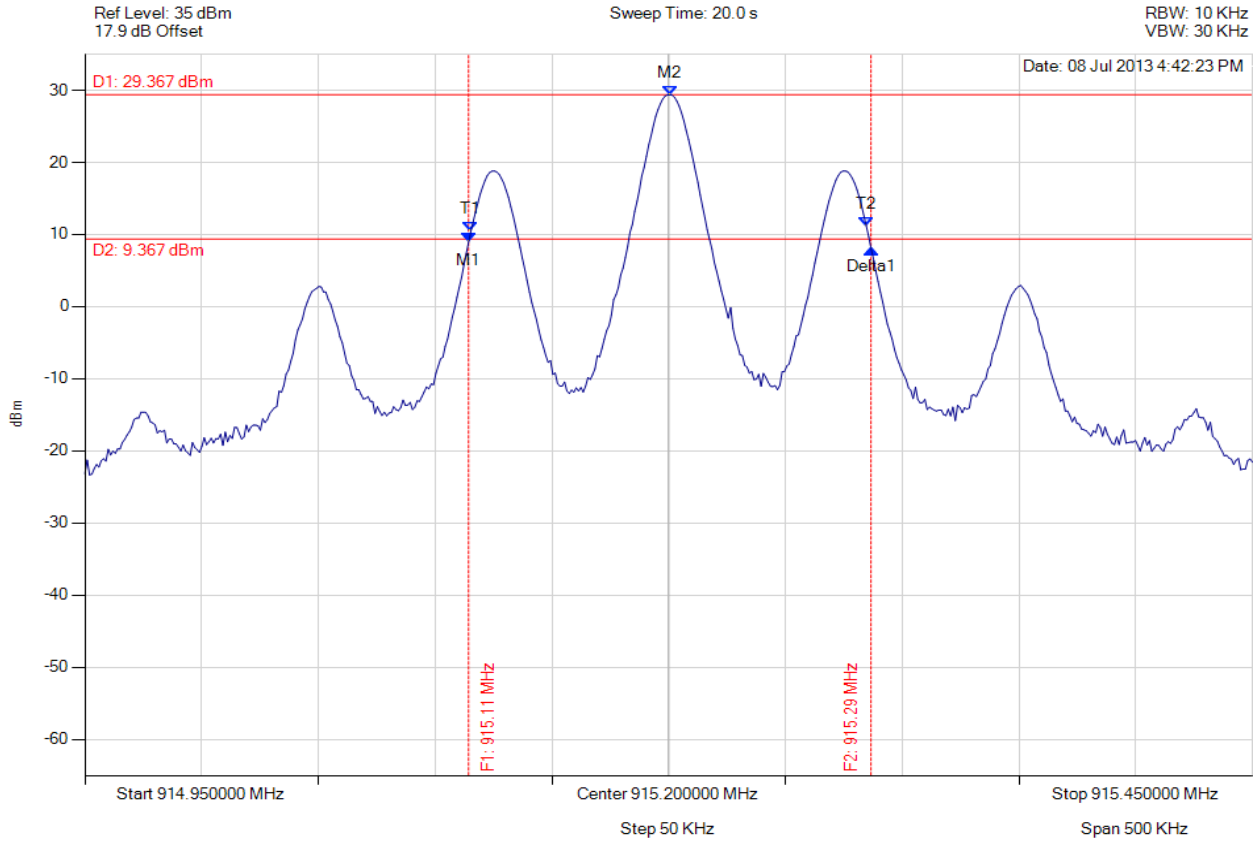

Analyser Setup	Marker : Frequency : Amplitude	Test Results
Detector = MAX PEAK Sweep Count = 0 RF Atten (dB) = 30 Trace Mode = VIEW	M1 : 915.114 MHz : 8.966 dBm M2 : 915.201 MHz : 29.367 dBm Delta1 : 172 KHz : -0.917 dB T1 : 915.115 MHz : 10.471 dBm T2 : 915.285 MHz : 11.132 dBm OBW : 169 KHz	Measured 20 dB Bandwidth: 0.172 MHz Limit: ≤250.0 kHz Margin: -78.0 kHz

[Back to the Matrix](#)

This test report may be reproduced in full only. The document may only be updated by MiCOM Labs personnel. Any changes will be noted in the Document History section of the report.



20 dB & 99% BANDWIDTH

Variant: FHSS, Channel: 927.50 MHz, Chain a, Temp: Ambient, Voltage: 4 Vdc

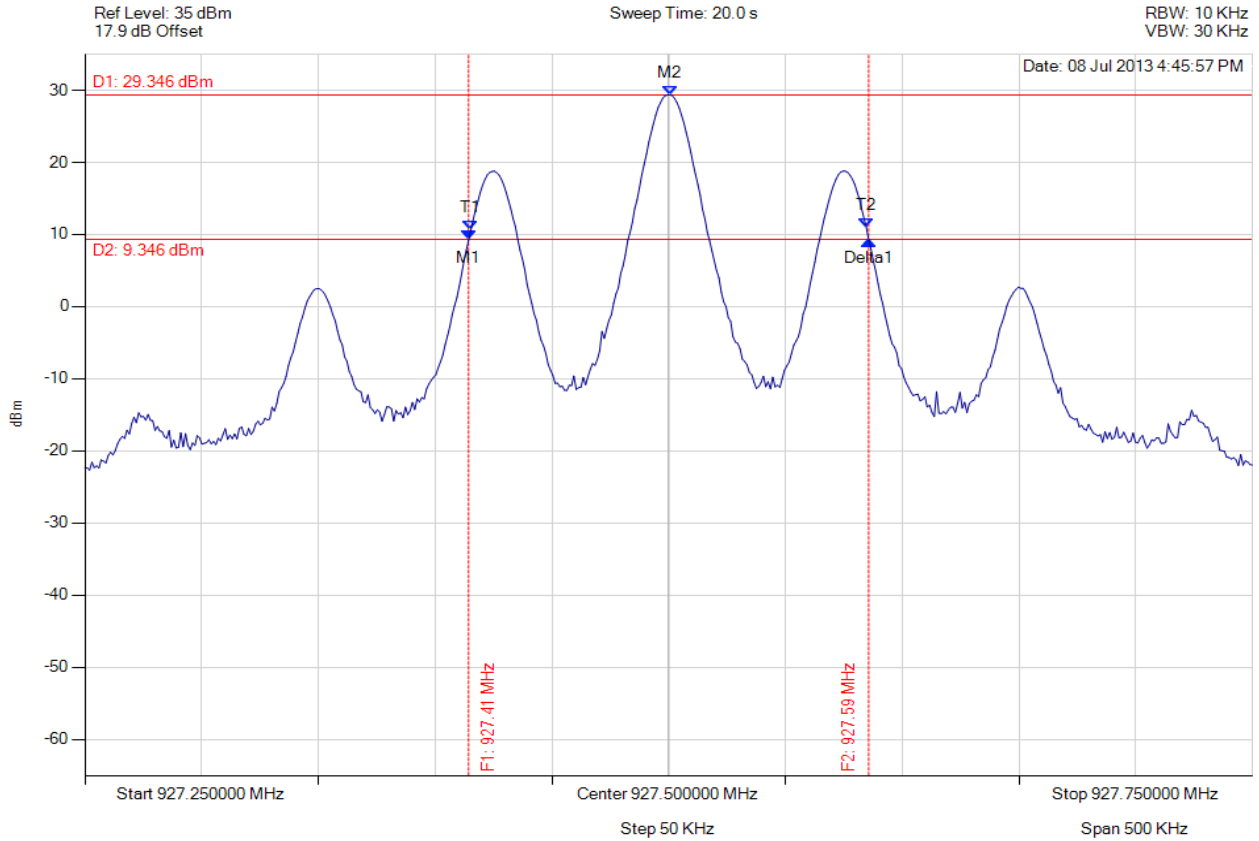

Analyser Setup	Marker : Frequency : Amplitude	Test Results
Detector = MAX PEAK Sweep Count = 0 RF Atten (dB) = 30 Trace Mode = VIEW	M1 : 927.414 MHz : 9.247 dBm M2 : 927.501 MHz : 29.346 dBm Delta1 : 171 KHz : -0.071 dB T1 : 927.415 MHz : 10.634 dBm T2 : 927.585 MHz : 10.953 dBm OBW : 169 KHz	Measured 20 dB Bandwidth: 0.171 MHz Limit: ≤250.0 kHz Margin: -79.0 kHz

[Back to the Matrix](#)

This test report may be reproduced in full only. The document may only be updated by MiCOM Labs personnel. Any changes will be noted in the Document History section of the report.



20 dB & 99% BANDWIDTH

Variant: FHSS, Channel: 902.40 MHz, Chain a, Temp: Ambient, Voltage: 4 Vdc

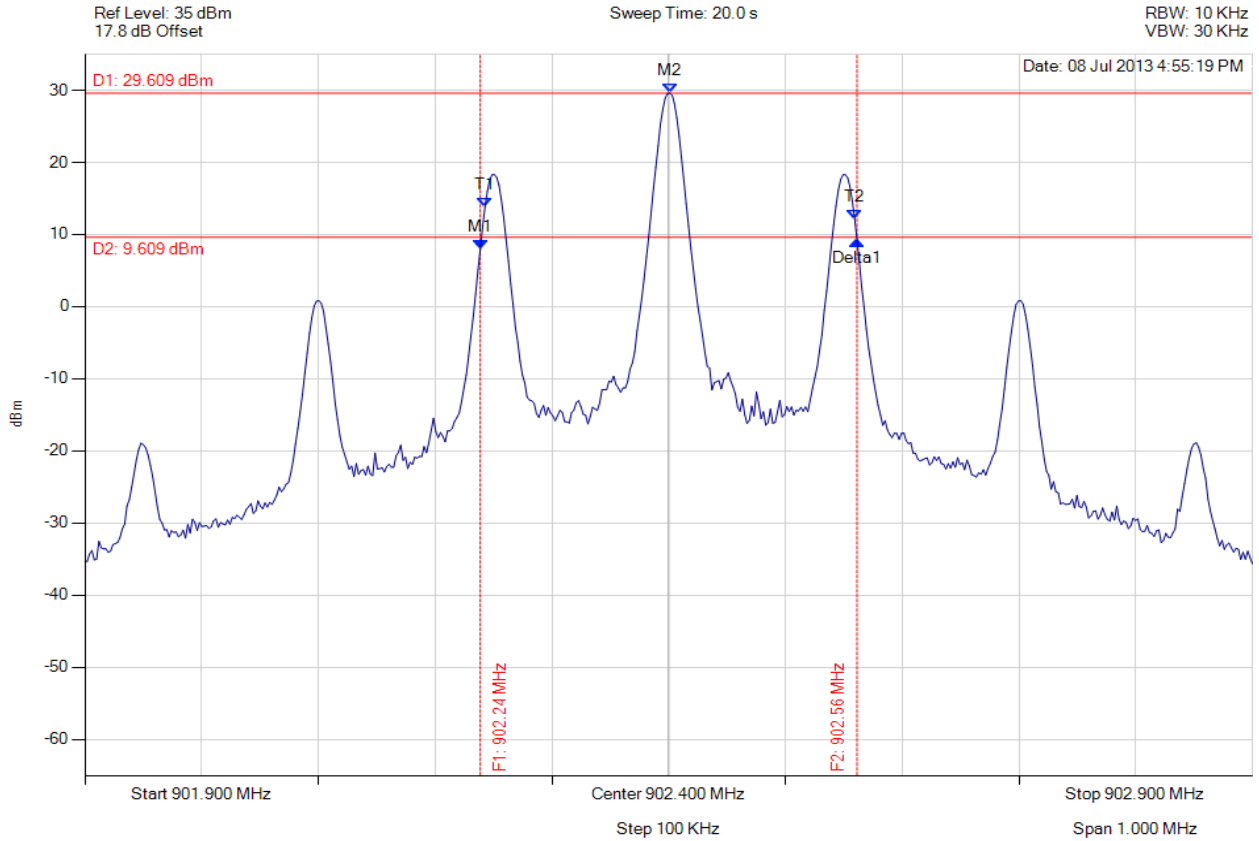

Analyser Setup	Marker : Frequency : Amplitude	Test Results
Detector = MAX PEAK Sweep Count = 0 RF Atten (dB) = 30 Trace Mode = VIEW	M1 : 902.239 MHz : 8.020 dBm M2 : 902.401 MHz : 29.609 dBm Delta1 : 323 KHz : 1.200 dB T1 : 902.243 MHz : 13.804 dBm T2 : 902.559 MHz : 12.135 dBm OBW : 317 KHz	Measured 20 dB Bandwidth: 0.323 MHz Limit: ≥250.0 kHz Margin: -73.0 kHz

[Back to the Matrix](#)

This test report may be reproduced in full only. The document may only be updated by MiCOM Labs personnel. Any changes will be noted in the Document History section of the report.



20 dB & 99% BANDWIDTH

Variant: FHSS, Channel: 915.20 MHz, Chain a, Temp: Ambient, Voltage: 4 Vdc

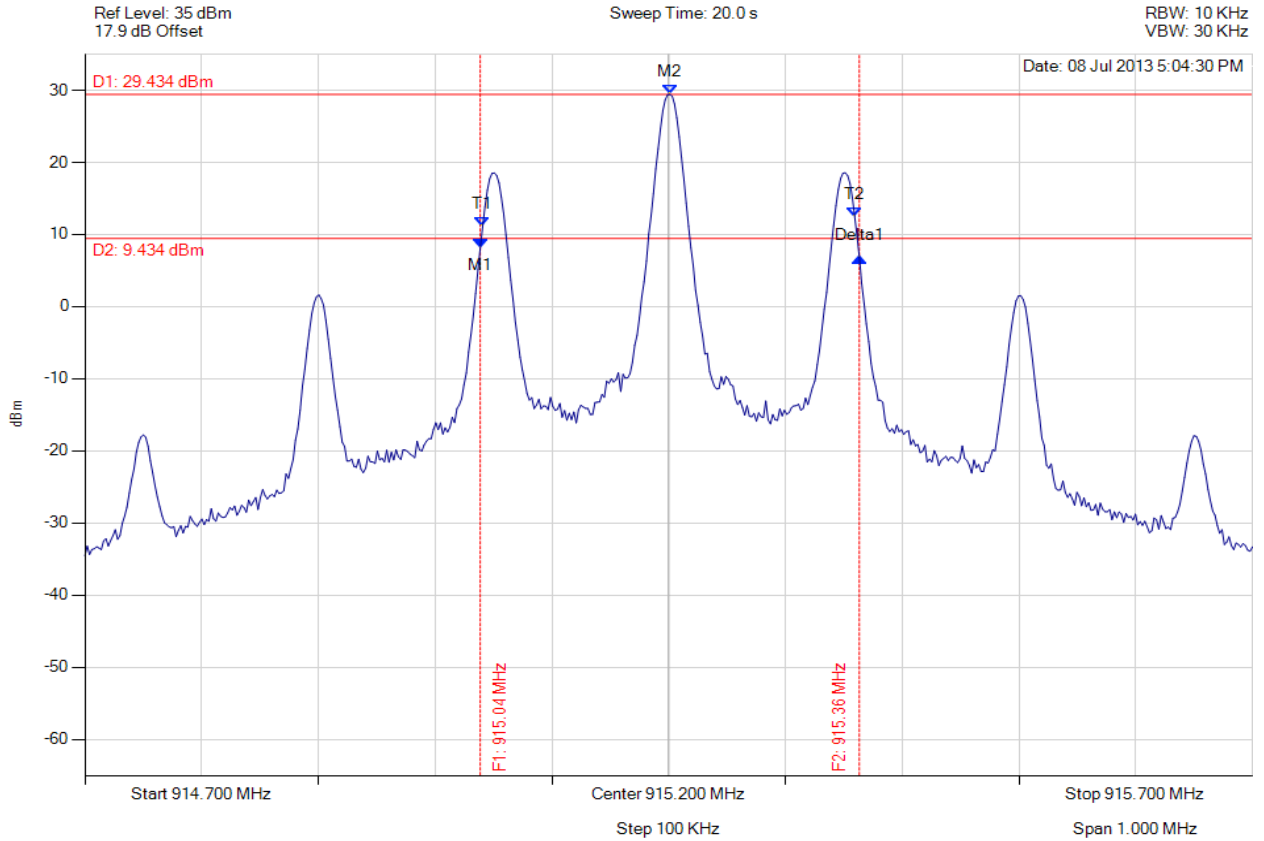

Analyser Setup	Marker : Frequency : Amplitude	Test Results
Detector = MAX PEAK Sweep Count = 0 RF Atten (dB) = 30 Trace Mode = VIEW	M1 : 915.039 MHz : 8.191 dBm M2 : 915.201 MHz : 29.434 dBm Delta1 : 325 KHz : -1.334 dB T1 : 915.041 MHz : 11.116 dBm T2 : 915.359 MHz : 12.480 dBm OBW : 319 KHz	Measured 20 dB Bandwidth: 0.325 MHz Limit: ≥250.0 kHz Margin: -75.0 kHz

[Back to the Matrix](#)

This test report may be reproduced in full only. The document may only be updated by MiCOM Labs personnel. Any changes will be noted in the Document History section of the report.



20 dB & 99% BANDWIDTH

Variant: FHSS, Channel: 927.60 MHz, Chain a, Temp: Ambient, Voltage: 4 Vdc

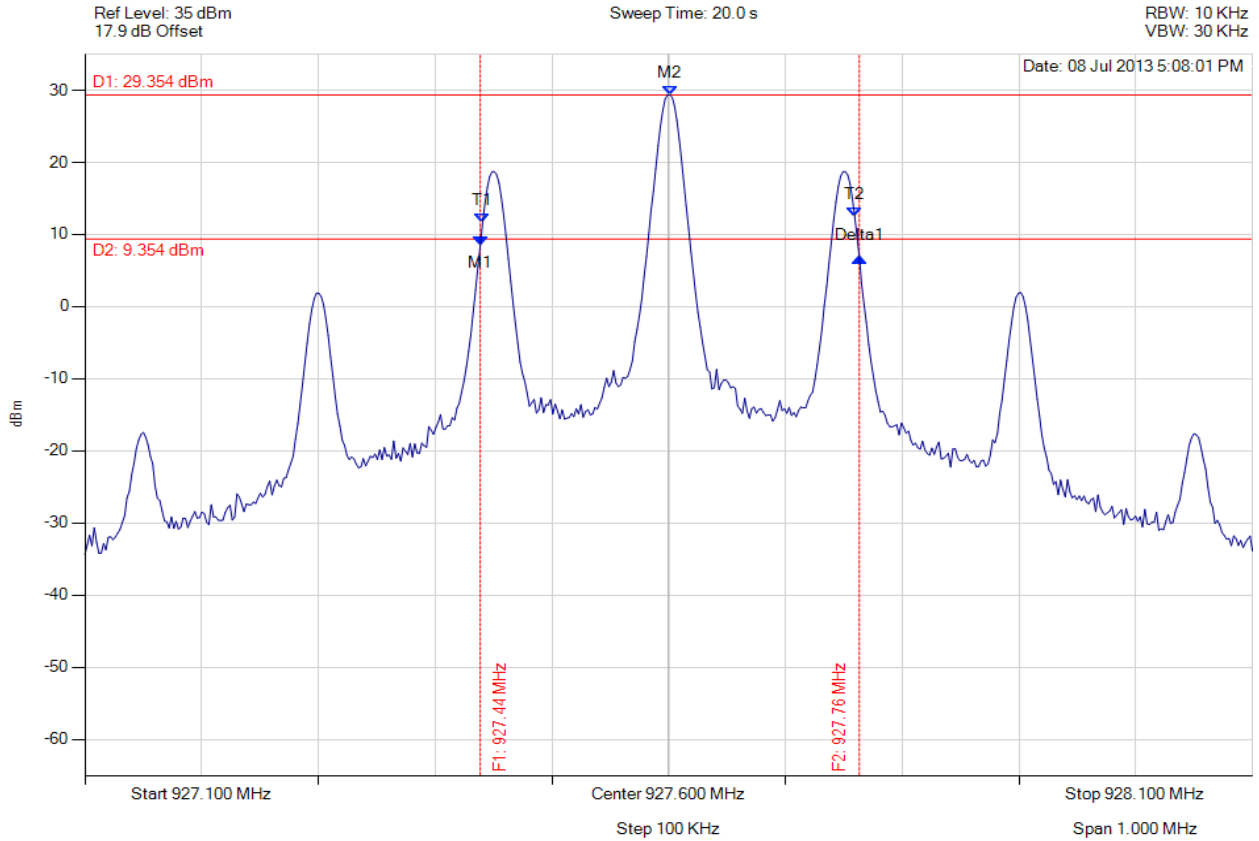

Analyser Setup	Marker : Frequency : Amplitude	Test Results
Detector = MAX PEAK Sweep Count = 0 RF Atten (dB) = 30 Trace Mode = VIEW	M1 : 927.439 MHz : 8.517 dBm M2 : 927.601 MHz : 29.354 dBm Delta1 : 325 KHz : -1.688 dB T1 : 927.441 MHz : 11.697 dBm T2 : 927.759 MHz : 12.511 dBm OBW : 319 KHz	Measured 20 dB Bandwidth: 0.325 MHz Limit: \geq 250.0 kHz Margin: -75.0 kHz

[Back to the Matrix](#)

This test report may be reproduced in full only. The document may only be updated by MiCOM Labs personnel. Any changes will be noted in the Document History section of the report.



Title: Silver Spring Network MicroAP
To: FCC 47 CFR Part15.247 & IC RSS-210
Serial #: SSNT62-U2 Rev A
Issue Date: 13th August 2013
Page: 111 of 147



20 dB & 99% BANDWIDTH

Variant: FHSS, Channel: 2400.80 MHz, Chain a, Temp: Ambient, Voltage: 4 Vdc

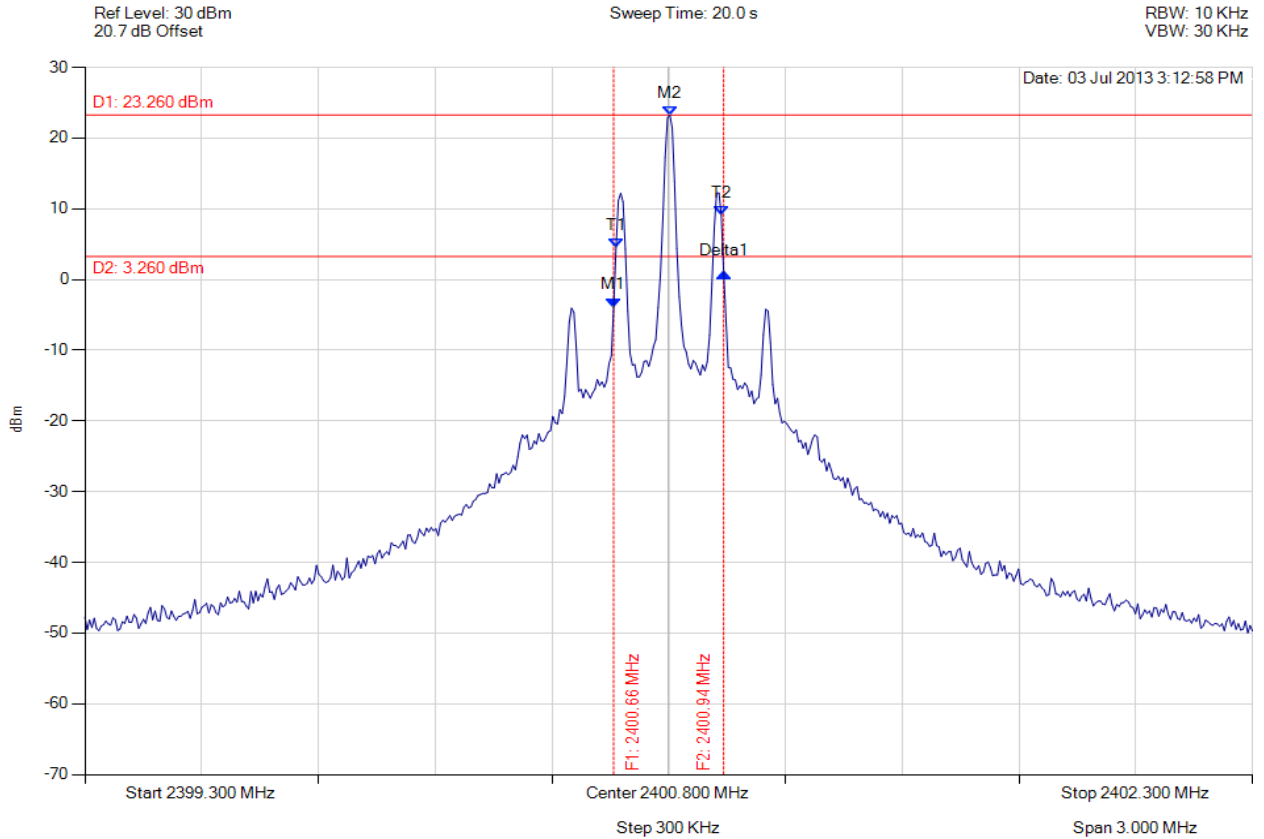

Analyser Setup	Marker : Frequency : Amplitude	Test Results
Detector = MAX PEAK Sweep Count = 0 RF Atten (dB) = 20 Trace Mode = VIEW	M1 : 2400.659 MHz : -3.919 dBm M2 : 2400.803 MHz : 23.260 dBm Delta1 : 283 KHz : 4.792 dB T1 : 2400.665 MHz : 4.558 dBm T2 : 2400.935 MHz : 9.054 dBm OBW : 271 KHz	Measured 20 dB Bandwidth: 0.283 MHz

[Back to the Matrix](#)

This test report may be reproduced in full only. The document may only be updated by MiCOM Labs personnel. Any changes will be noted in the Document History section of the report.



20 dB & 99% BANDWIDTH

Variant: FHSS, Channel: 2440.00 MHz, Chain a, Temp: Ambient, Voltage: 4 Vdc

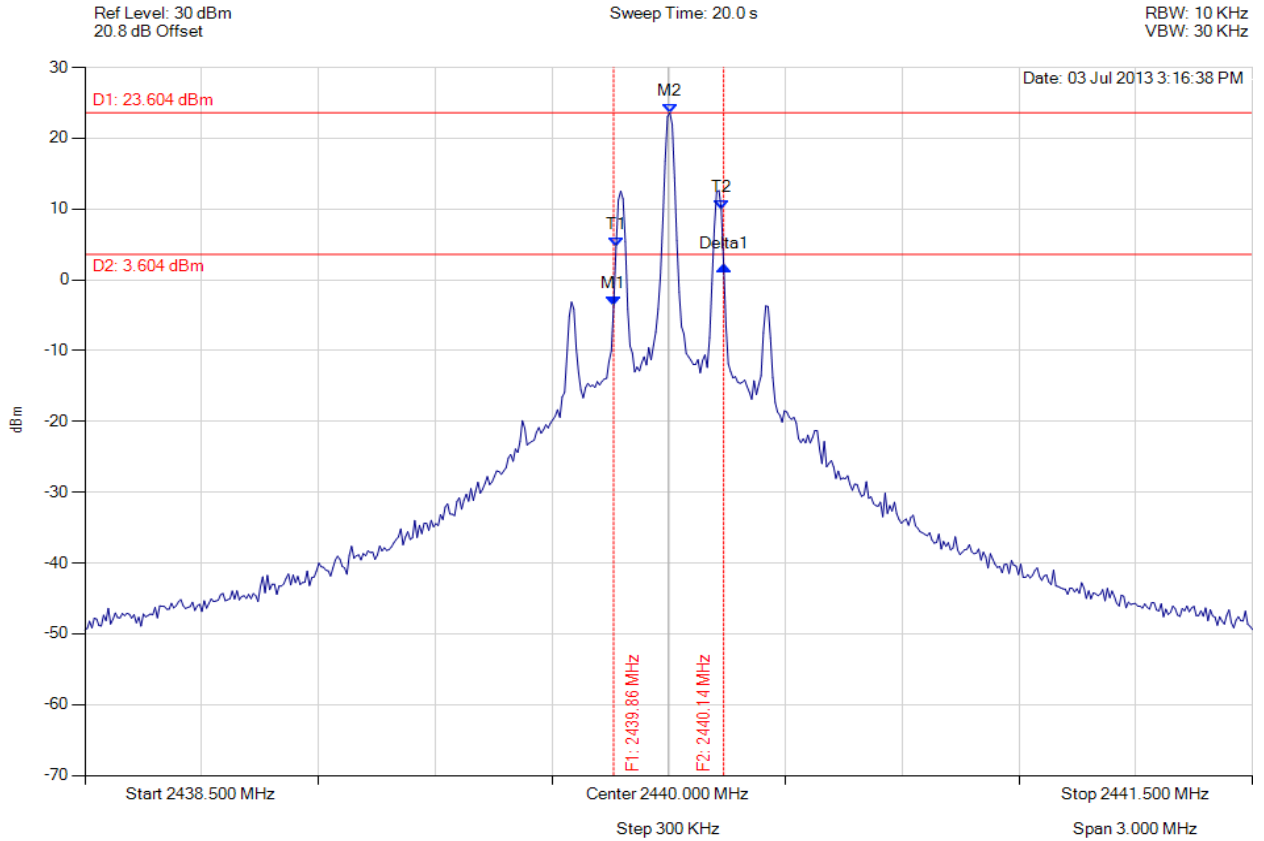

Analyser Setup	Marker : Frequency : Amplitude	Test Results
Detector = MAX PEAK Sweep Count = 0 RF Atten (dB) = 20 Trace Mode = VIEW	M1 : 2439.859 MHz : -3.638 dBm M2 : 2440.003 MHz : 23.604 dBm Delta1 : 283 KHz : 5.524 dB T1 : 2439.865 MHz : 4.605 dBm T2 : 2440.135 MHz : 9.903 dBm OBW : 271 KHz	Measured 20 dB Bandwidth: 0.283 MHz

[Back to the Matrix](#)

This test report may be reproduced in full only. The document may only be updated by MiCOM Labs personnel. Any changes will be noted in the Document History section of the report.



Title: Silver Spring Network MicroAP
To: FCC 47 CFR Part15.247 & IC RSS-210
Serial #: SSNT62-U2 Rev A
Issue Date: 13th August 2013
Page: 113 of 147



20 dB & 99% BANDWIDTH

Variant: FHSS, Channel: 2472.80 MHz, Chain a, Temp: Ambient, Voltage: 4 Vdc

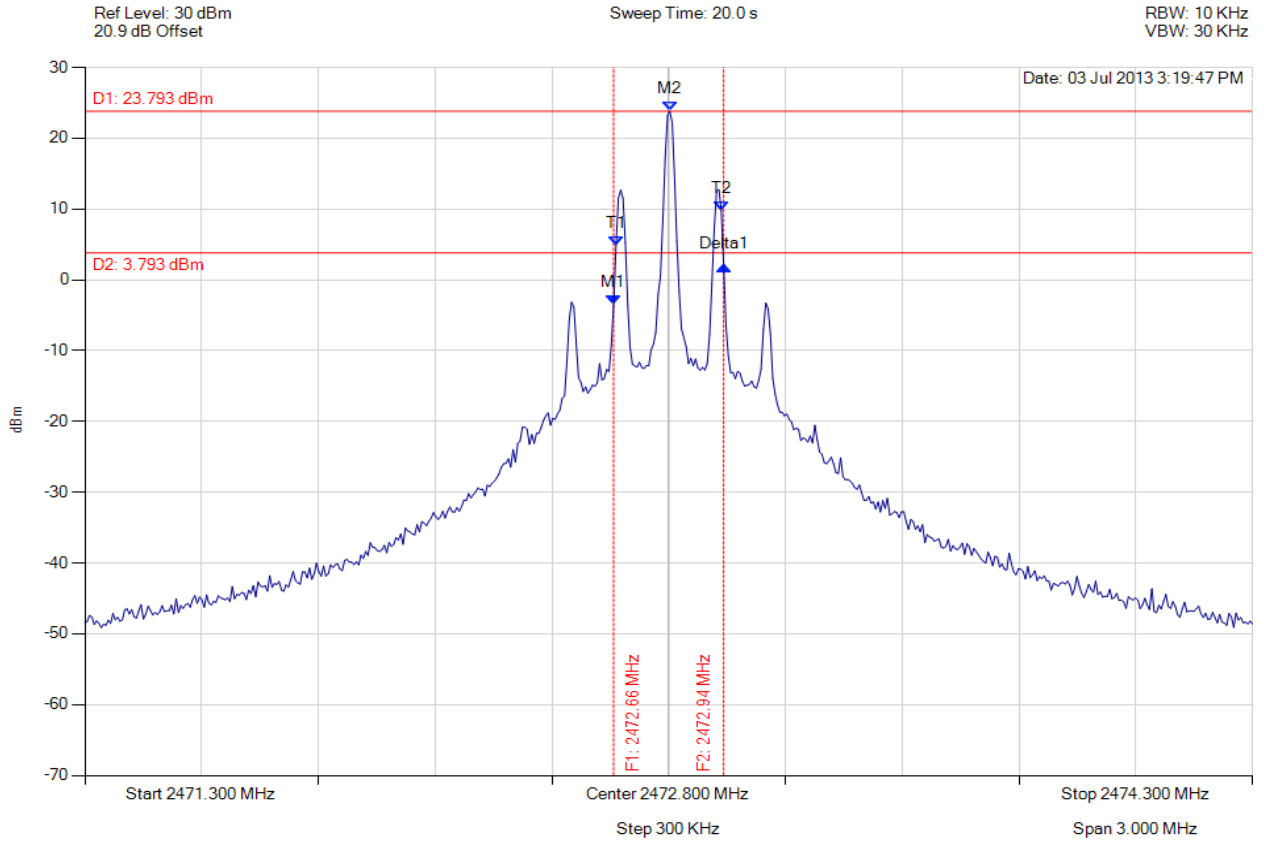

Analyser Setup	Marker : Frequency : Amplitude	Test Results
Detector = MAX PEAK Sweep Count = 0 RF Atten (dB) = 20 Trace Mode = VIEW	M1 : 2472.659 MHz : -3.412 dBm M2 : 2472.803 MHz : 23.793 dBm Delta1 : 283 KHz : 5.337 dB T1 : 2472.665 MHz : 4.908 dBm T2 : 2472.935 MHz : 9.707 dBm OBW : 271 KHz	Measured 20 dB Bandwidth: 0.283 MHz

[Back to the Matrix](#)

This test report may be reproduced in full only. The document may only be updated by MiCOM Labs personnel. Any changes will be noted in the Document History section of the report.



Title: Silver Spring Network MicroAP
To: FCC 47 CFR Part15.247 & IC RSS-210
Serial #: SSNT62-U2 Rev A
Issue Date: 13th August 2013
Page: 114 of 147



20 dB & 99% BANDWIDTH

Variant: FHSS, Channel: 2400.80 MHz, Chain a, Temp: Ambient, Voltage: 4 Vdc

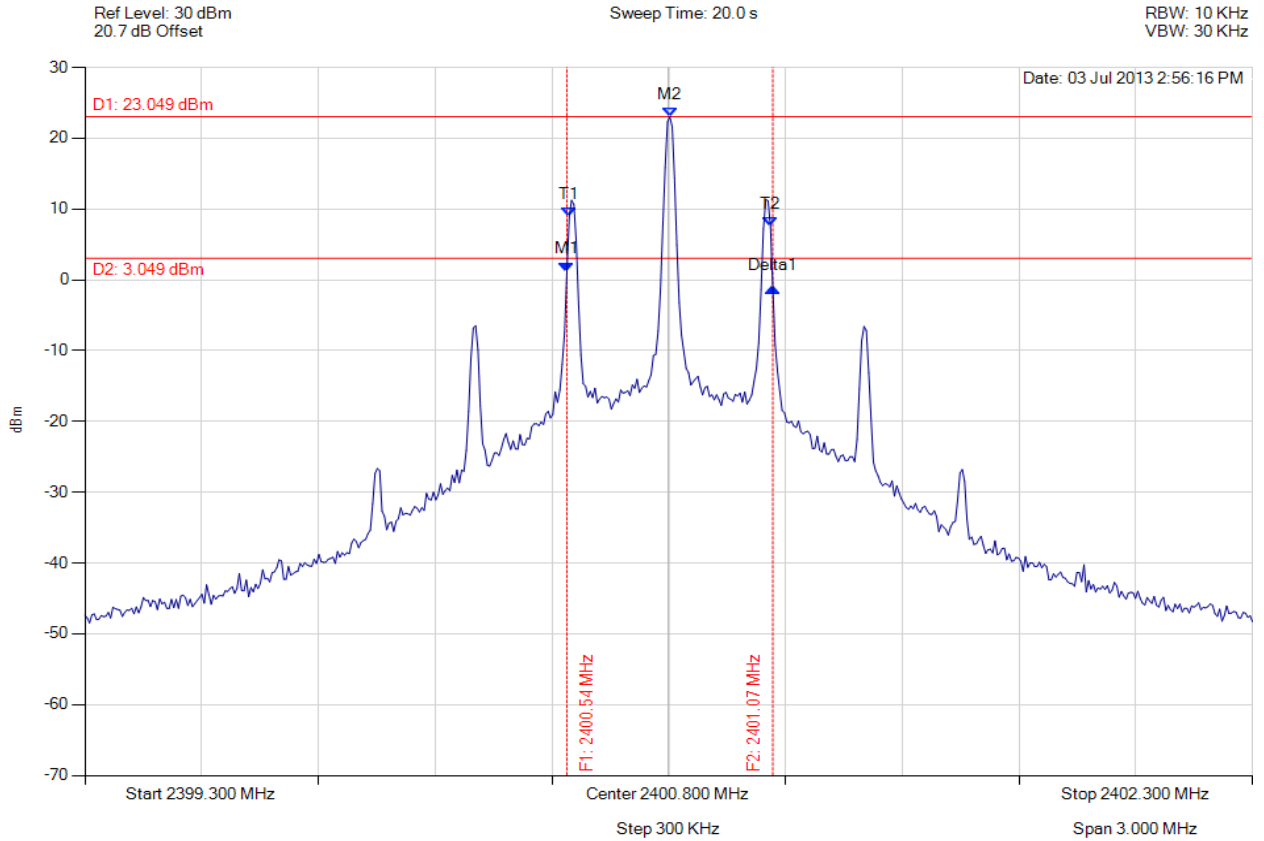

Analyser Setup	Marker : Frequency : Amplitude	Test Results
Detector = MAX PEAK Sweep Count = 0 RF Atten (dB) = 20 Trace Mode = VIEW	M1 : 2400.538 MHz : 1.186 dBm M2 : 2400.803 MHz : 23.049 dBm Delta1 : 529 KHz : -2.339 dB T1 : 2400.544 MHz : 8.902 dBm T2 : 2401.062 MHz : 7.480 dBm OBW : 517 KHz	Measured 20 dB Bandwidth: 0.529 MHz

[Back to the Matrix](#)

This test report may be reproduced in full only. The document may only be updated by MiCOM Labs personnel. Any changes will be noted in the Document History section of the report.



Title: Silver Spring Network MicroAP
To: FCC 47 CFR Part15.247 & IC RSS-210
Serial #: SSNT62-U2 Rev A
Issue Date: 13th August 2013
Page: 115 of 147



20 dB & 99% BANDWIDTH

Variant: FHSS, Channel: 2440.00 MHz, Chain a, Temp: Ambient, Voltage: 4 Vdc

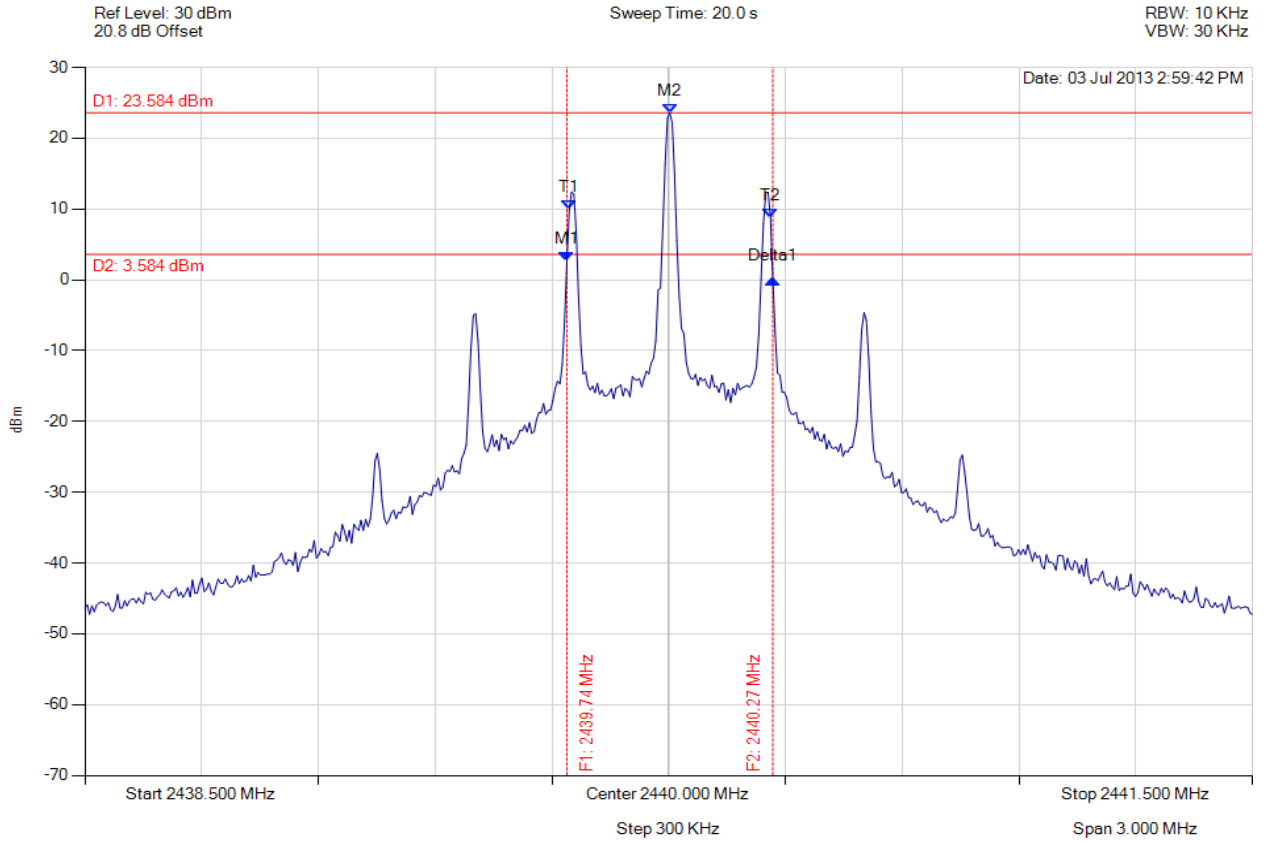

Analyser Setup	Marker : Frequency : Amplitude	Test Results
Detector = MAX PEAK Sweep Count = 0 RF Atten (dB) = 20 Trace Mode = VIEW	M1 : 2439.738 MHz : 2.589 dBm M2 : 2440.003 MHz : 23.584 dBm Delta1 : 529 KHz : -2.426 dB T1 : 2439.744 MHz : 9.892 dBm T2 : 2440.262 MHz : 8.788 dBm OBW : 517 KHz	Measured 20 dB Bandwidth: 0.529 MHz

[Back to the Matrix](#)

This test report may be reproduced in full only. The document may only be updated by MiCOM Labs personnel. Any changes will be noted in the Document History section of the report.



Title: Silver Spring Network MicroAP
To: FCC 47 CFR Part15.247 & IC RSS-210
Serial #: SSNT62-U2 Rev A
Issue Date: 13th August 2013
Page: 116 of 147



20 dB & 99% BANDWIDTH

Variant: FHSS, Channel: 2472.80 MHz, Chain a, Temp: Ambient, Voltage: 4 Vdc

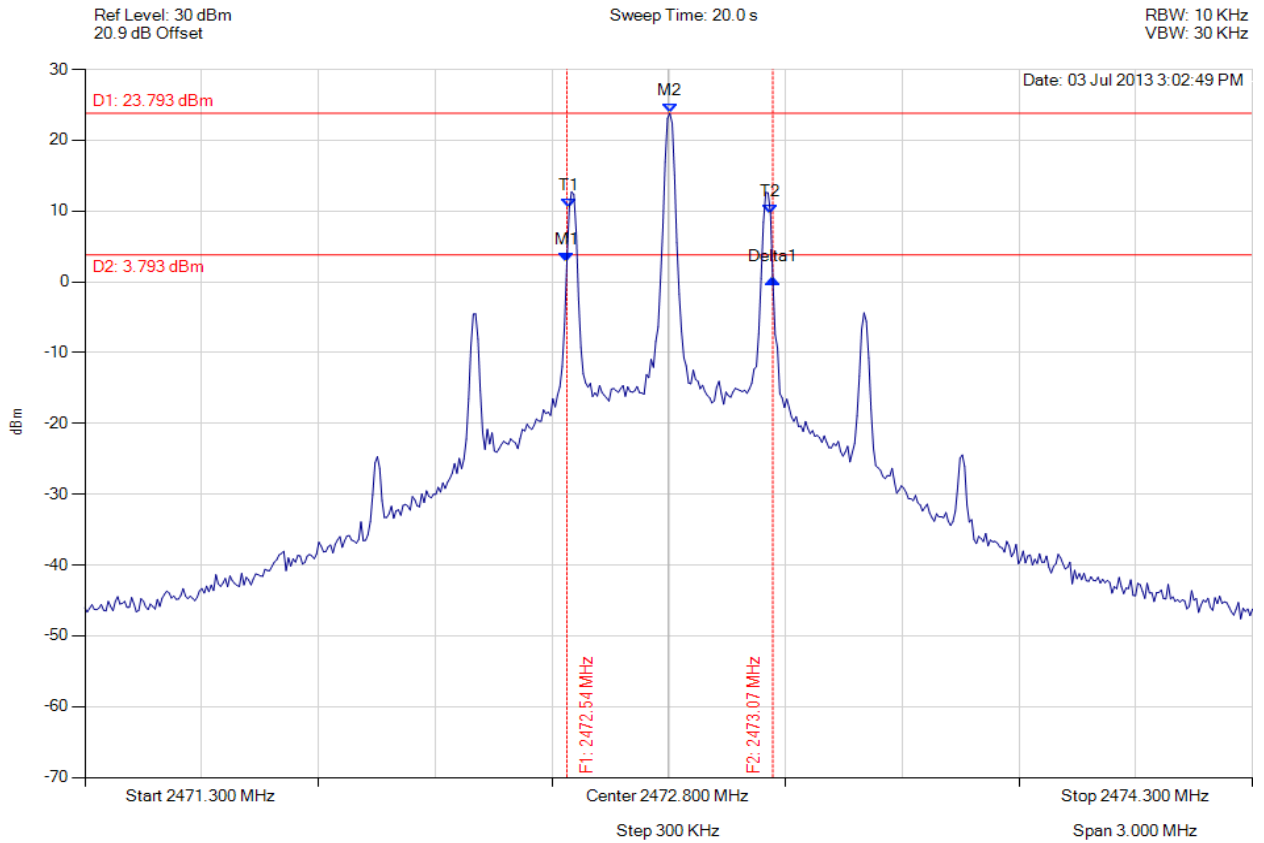

Analyser Setup	Marker : Frequency : Amplitude	Test Results
Detector = MAX PEAK Sweep Count = 0 RF Atten (dB) = 20 Trace Mode = VIEW	M1 : 2472.538 MHz : 2.738 dBm M2 : 2472.803 MHz : 23.793 dBm Delta1 : 529 KHz : -2.363 dB T1 : 2472.544 MHz : 10.425 dBm T2 : 2473.062 MHz : 9.610 dBm OBW : 517 KHz	Measured 20 dB Bandwidth: 0.529 MHz

[Back to the Matrix](#)

This test report may be reproduced in full only. The document may only be updated by MiCOM Labs personnel. Any changes will be noted in the Document History section of the report.



Title: Silver Spring Network MicroAP
To: FCC 47 CFR Part15.247 & IC RSS-210
Serial #: SSNT62-U2 Rev A
Issue Date: 13th August 2013
Page: 117 of 147

A.1.2. Conducted Spurious and Band-Edge Emissions



CONDUCTED HIGH BAND-EDGE EMISSIONS - PEAK

Variant: FHSS, Channel: 902.30 MHz, Chain a, Temp: Ambient, Voltage: 4 Vdc

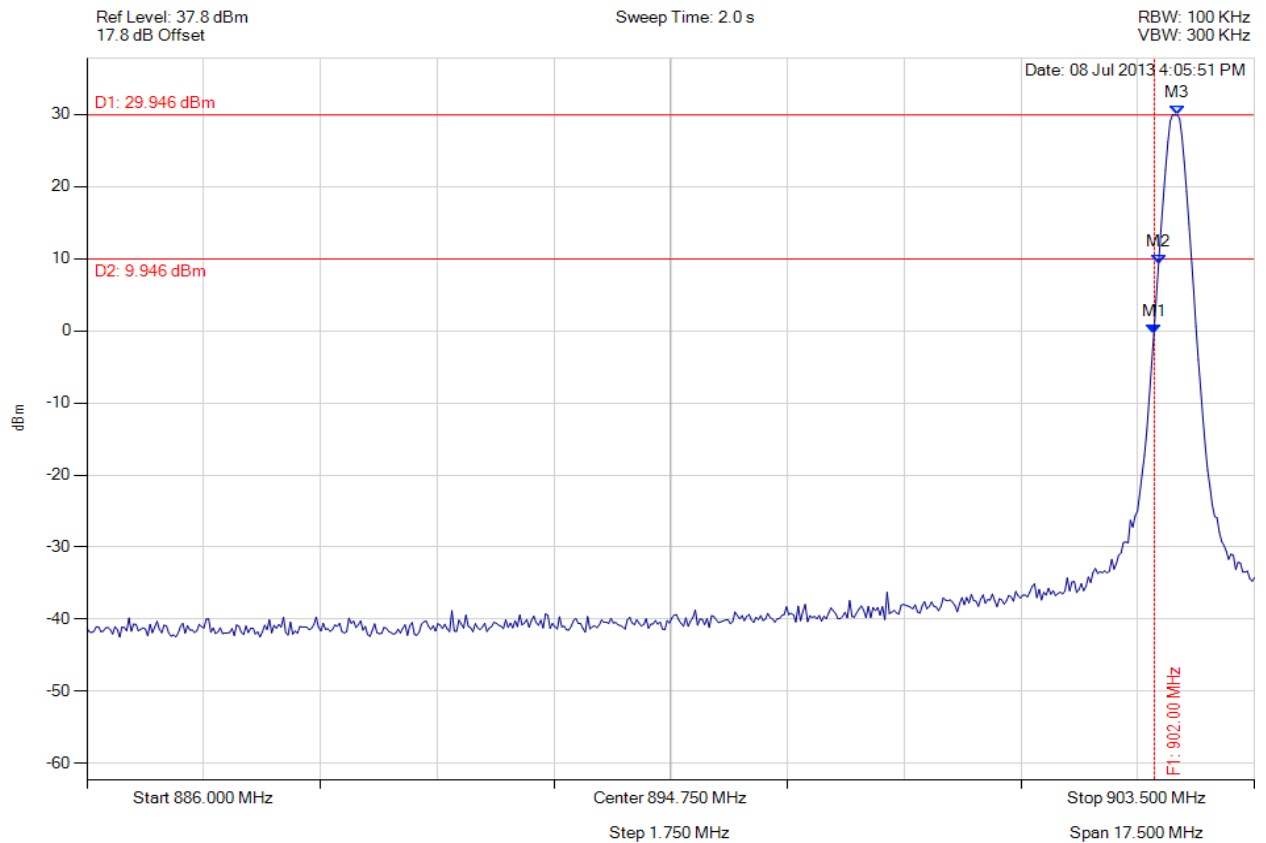

Analyser Setup	Marker : Frequency : Amplitude	Test Results
Detector = MAX PEAK Sweep Count = 0 RF Atten (dB) = 30 Trace Mode = VIEW	M1 : 902.000 MHz : -0.469 dBm M2 : 902.062 MHz : 9.216 dBm M3 : 902.343 MHz : 29.946 dBm	Limit: 9.95 dBm Margin: -10.42 dB

[Back to the Matrix](#)

This test report may be reproduced in full only. The document may only be updated by MiCOM Labs personnel. Any changes will be noted in the Document History section of the report.



Title: Silver Spring Network MicroAP
To: FCC 47 CFR Part15.247 & IC RSS-210
Serial #: SSNT62-U2 Rev A
Issue Date: 13th August 2013
Page: 118 of 147



CONDUCTED HIGH BAND-EDGE EMISSIONS - PEAK

Variant: FHSS, Channel: 927.50 MHz, Chain a, Temp: Ambient, Voltage: 4 Vdc

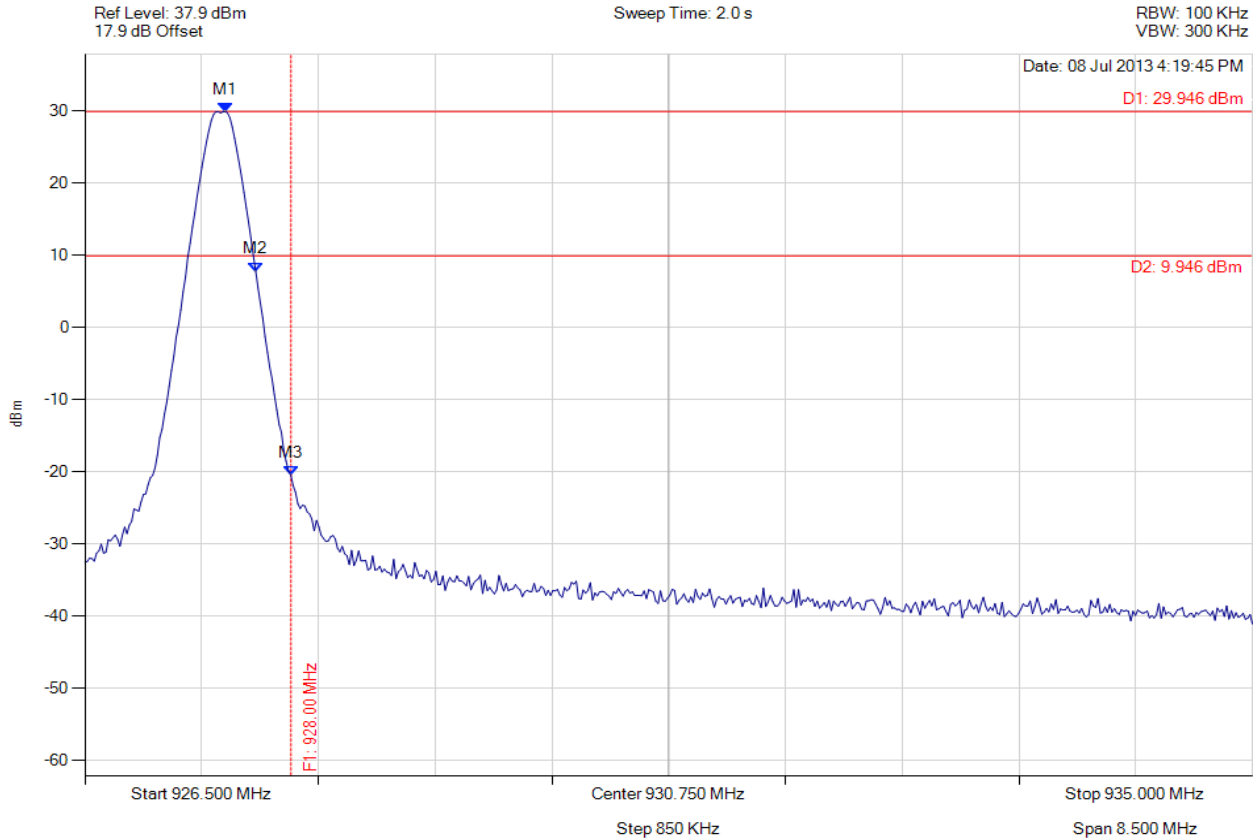

Analyser Setup	Marker : Frequency : Amplitude	Test Results
Detector = MAX PEAK Sweep Count = 0 RF Atten (dB) = 30 Trace Mode = VIEW	M1 : 927.522 MHz : 29.946 dBm M2 : 927.743 MHz : 7.778 dBm M3 : 928.000 MHz : -20.426 dBm	Limit: 9.95 dBm Margin: -30.38 dB

[Back to the Matrix](#)

This test report may be reproduced in full only. The document may only be updated by MiCOM Labs personnel. Any changes will be noted in the Document History section of the report.



Title: Silver Spring Network MicroAP
To: FCC 47 CFR Part15.247 & IC RSS-210
Serial #: SSNT62-U2 Rev A
Issue Date: 13th August 2013
Page: 119 of 147



CONDUCTED SPURIOUS EMISSIONS - PEAK

Variants: FHSS, Channel: 902.30 MHz, Chain a, Temp: Ambient, Voltage: 4 Vdc

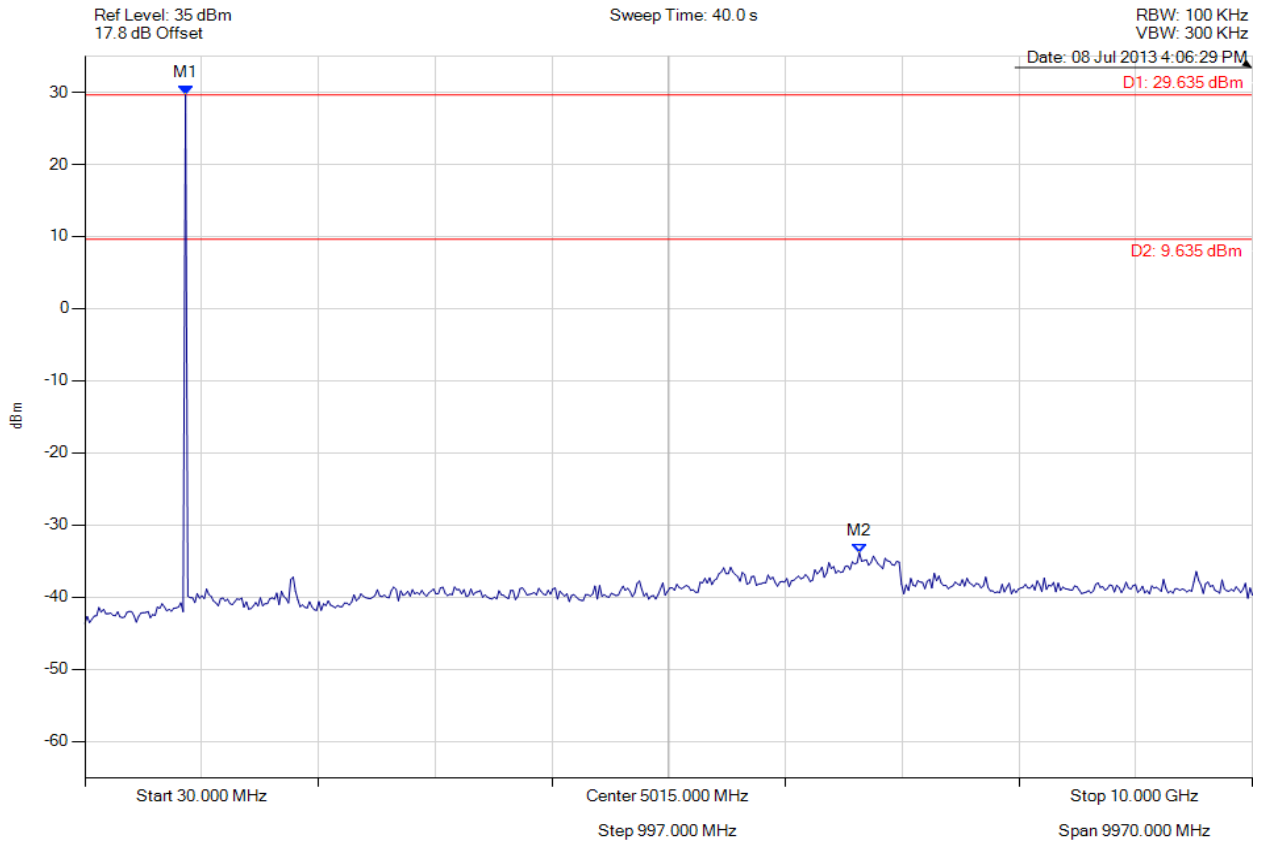

Analyser Setup	Marker : Frequency : Amplitude	Test Results
Detector = MAX PEAK Sweep Count = 0 RF Atten (dB) = 30 Trace Mode = VIEW	M1 : 889.138 MHz : 29.635 dBm M2 : 6643.367 MHz : -33.850 dBm	Limit: 9.64 dBm Margin: -43.49 dB

[Back to the Matrix](#)

This test report may be reproduced in full only. The document may only be updated by MiCOM Labs personnel. Any changes will be noted in the Document History section of the report.



Title: Silver Spring Network MicroAP
To: FCC 47 CFR Part15.247 & IC RSS-210
Serial #: SSNT62-U2 Rev A
Issue Date: 13th August 2013
Page: 120 of 147



CONDUCTED SPURIOUS EMISSIONS - PEAK

Variants: FHSS, Channel: 915.20 MHz, Chain a, Temp: Ambient, Voltage: 4 Vdc

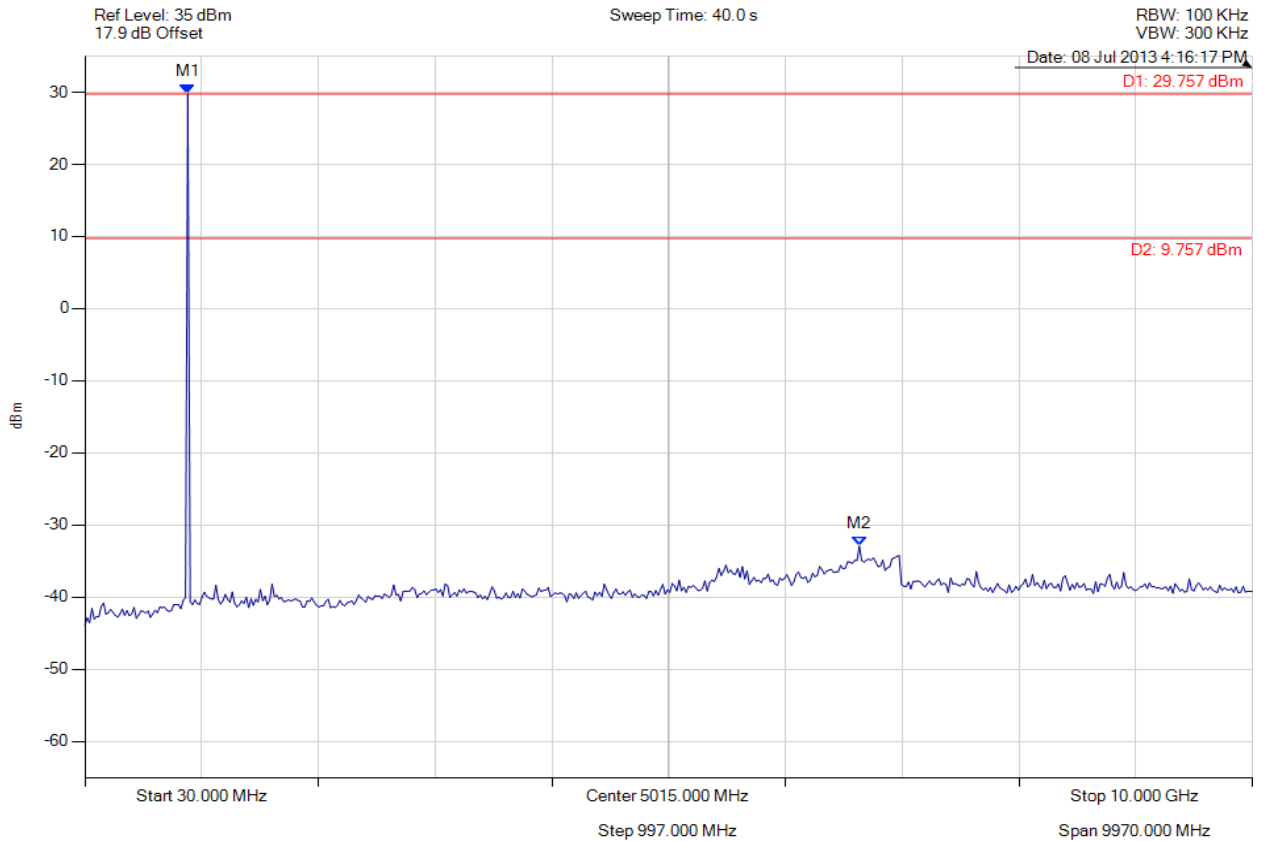

Analyser Setup	Marker : Frequency : Amplitude	Test Results
Detector = MAX PEAK Sweep Count = 0 RF Atten (dB) = 30 Trace Mode = VIEW	M1 : 909.118 MHz : 29.757 dBm M2 : 6643.367 MHz : -32.927 dBm	Limit: 9.76 dBm Margin: -42.69 dB

[Back to the Matrix](#)

This test report may be reproduced in full only. The document may only be updated by MiCOM Labs personnel. Any changes will be noted in the Document History section of the report.



Title: Silver Spring Network MicroAP
To: FCC 47 CFR Part15.247 & IC RSS-210
Serial #: SSNT62-U2 Rev A
Issue Date: 13th August 2013
Page: 121 of 147



CONDUCTED SPURIOUS EMISSIONS - PEAK

Variant: FHSS, Channel: 927.50 MHz, Chain a, Temp: Ambient, Voltage: 4 Vdc

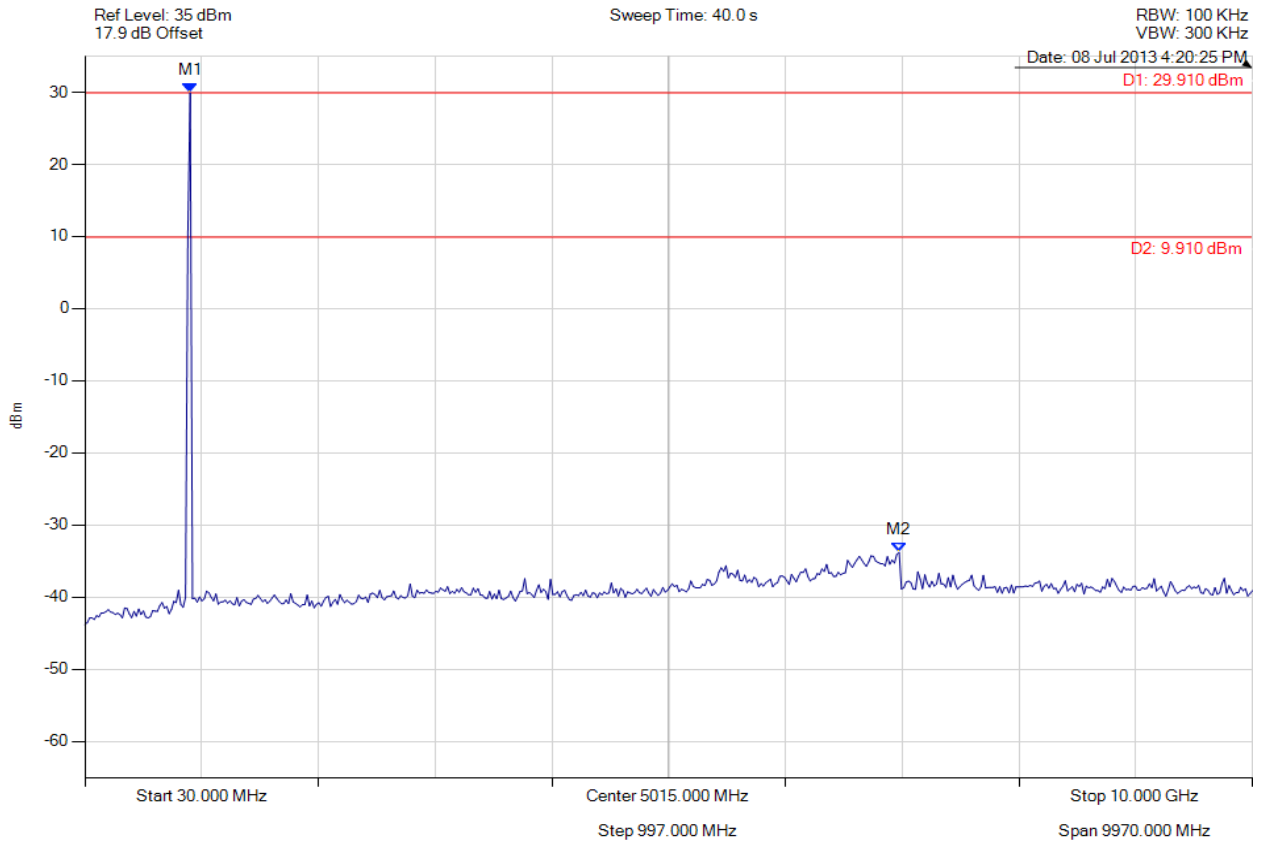

Analyser Setup	Marker : Frequency : Amplitude	Test Results
Detector = MAX PEAK Sweep Count = 0 RF Atten (dB) = 30 Trace Mode = VIEW	M1 : 929.098 MHz : 29.910 dBm M2 : 6983.026 MHz : -33.800 dBm	Limit: 9.91 dBm Margin: -43.71 dB

[Back to the Matrix](#)

This test report may be reproduced in full only. The document may only be updated by MiCOM Labs personnel. Any changes will be noted in the Document History section of the report.



Title: Silver Spring Network MicroAP
To: FCC 47 CFR Part15.247 & IC RSS-210
Serial #: SSNT62-U2 Rev A
Issue Date: 13th August 2013
Page: 122 of 147



CONDUCTED HIGH BAND-EDGE EMISSIONS - PEAK

Variants: FHSS, Channel: 902.40 MHz, Chain a, Temp: Ambient, Voltage: 4 Vdc

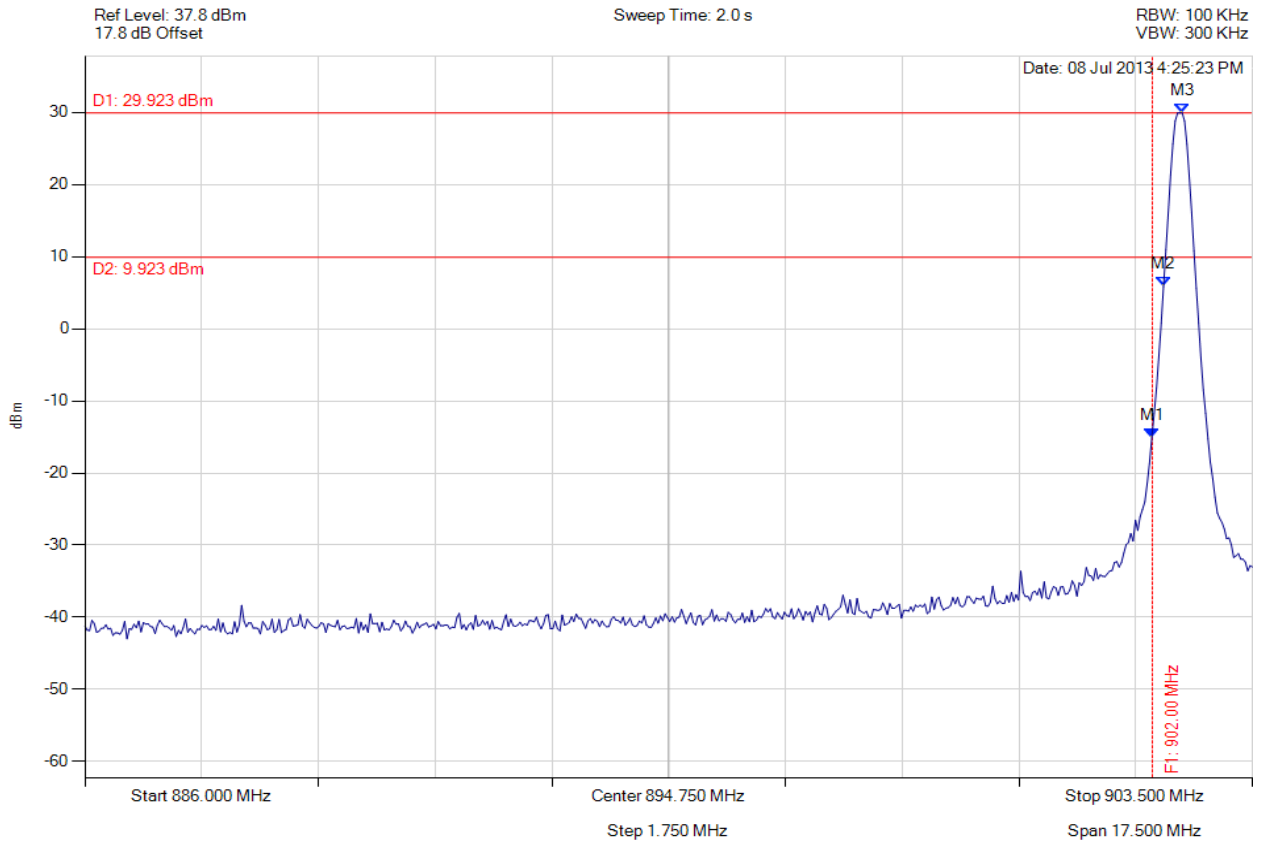

Analyser Setup	Marker : Frequency : Amplitude	Test Results
Detector = MAX PEAK Sweep Count = 0 RF Atten (dB) = 30 Trace Mode = VIEW	M1 : 902.000 MHz : -15.047 dBm M2 : 902.167 MHz : 5.862 dBm M3 : 902.448 MHz : 29.923 dBm	Limit: 9.92 dBm Margin: -24.97 dB

[Back to the Matrix](#)

This test report may be reproduced in full only. The document may only be updated by MiCOM Labs personnel. Any changes will be noted in the Document History section of the report.



Title: Silver Spring Network MicroAP
To: FCC 47 CFR Part15.247 & IC RSS-210
Serial #: SSNT62-U2 Rev A
Issue Date: 13th August 2013
Page: 123 of 147



CONDUCTED HIGH BAND-EDGE EMISSIONS - PEAK

Variant: FHSS, Channel: 927.80 MHz, Chain a, Temp: Ambient, Voltage: 4 Vdc

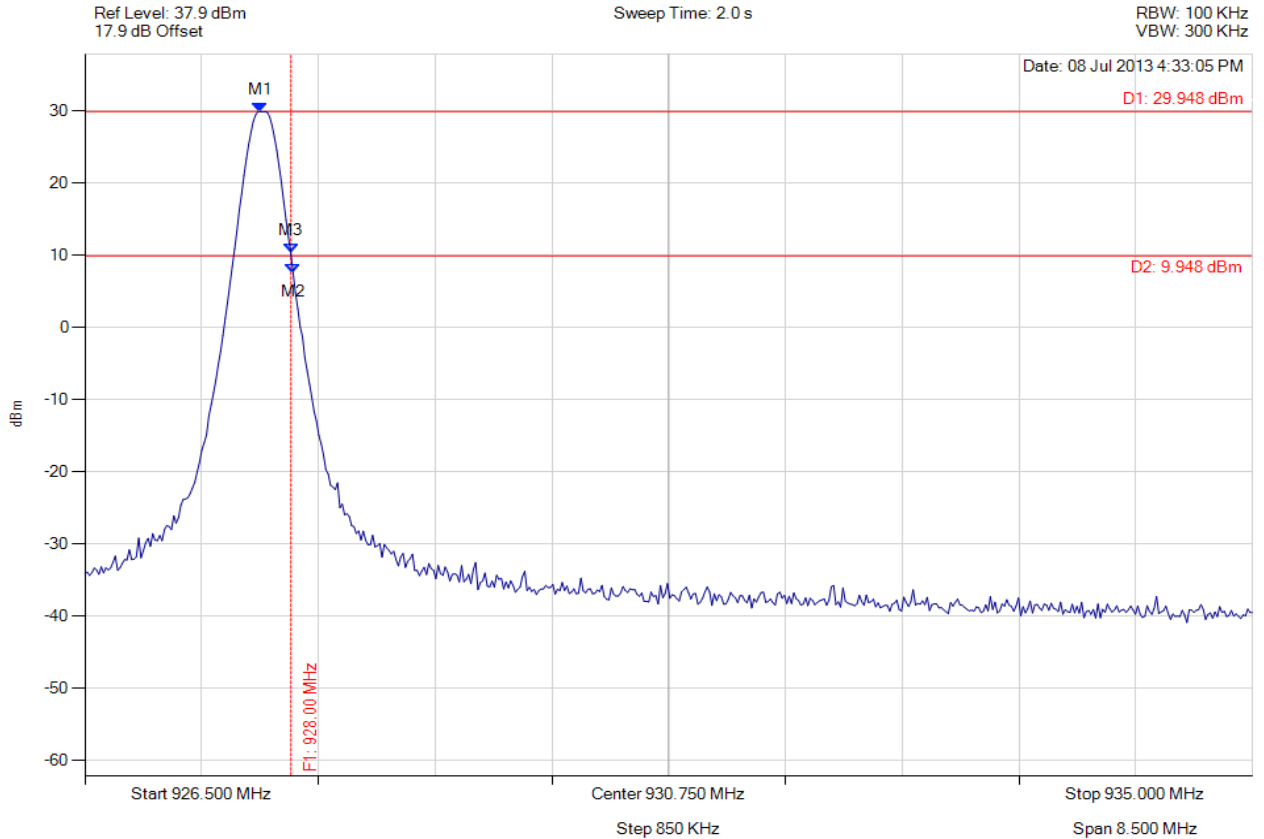

Analyser Setup	Marker : Frequency : Amplitude	Test Results
Detector = MAX PEAK Sweep Count = 0 RF Atten (dB) = 30 Trace Mode = VIEW	M1 : 927.778 MHz : 29.948 dBm M2 : 928.016 MHz : 7.544 dBm M3 : 928.000 MHz : 9.931 dBm	Limit: 9.95 dBm Margin: -0.019 dB

[Back to the Matrix](#)

This test report may be reproduced in full only. The document may only be updated by MiCOM Labs personnel. Any changes will be noted in the Document History section of the report.



Title: Silver Spring Network MicroAP
To: FCC 47 CFR Part15.247 & IC RSS-210
Serial #: SSNT62-U2 Rev A
Issue Date: 13th August 2013
Page: 124 of 147



CONDUCTED SPURIOUS EMISSIONS - PEAK

Variants: FHSS, Channel: 902.40 MHz, Chain a, Temp: Ambient, Voltage: 4 Vdc

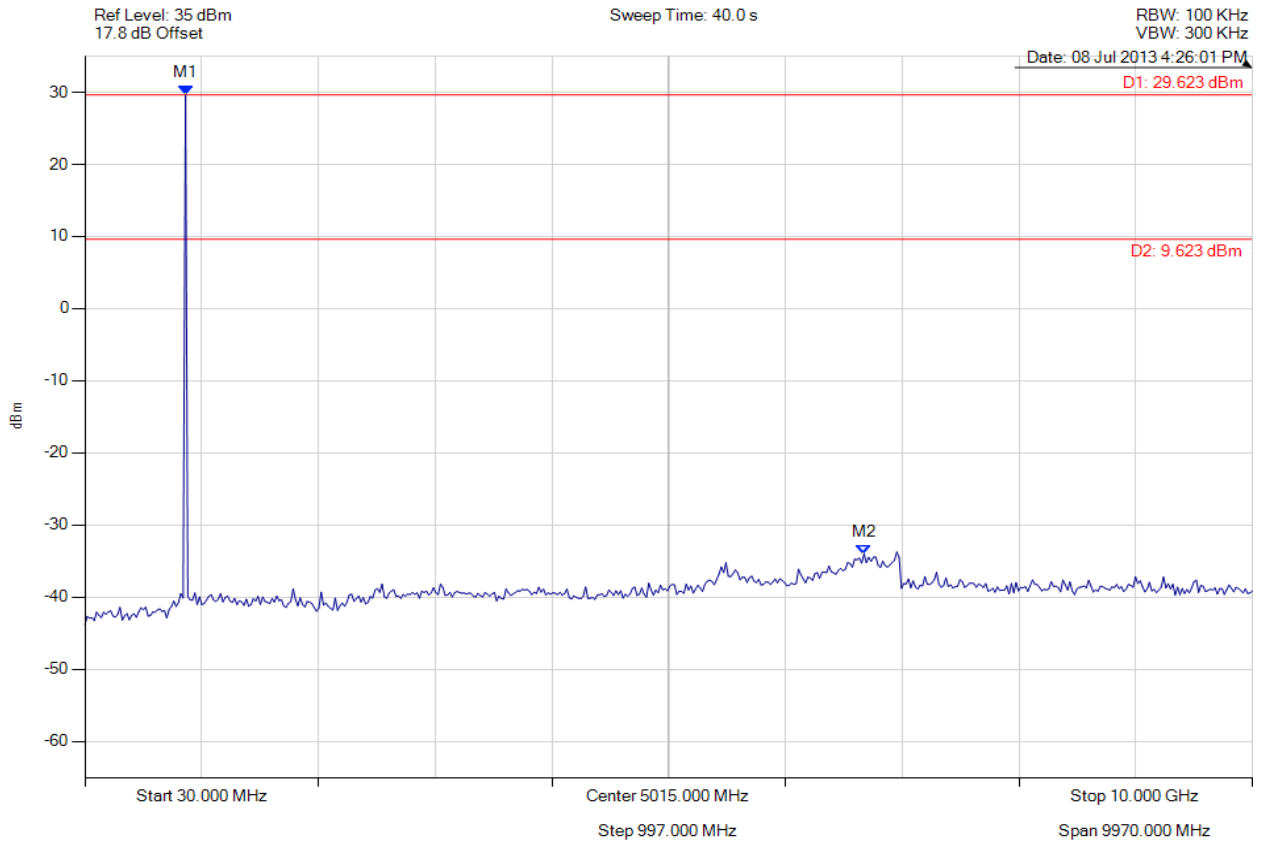

Analyser Setup	Marker : Frequency : Amplitude	Test Results
Detector = MAX PEAK Sweep Count = 0 RF Atten (dB) = 30 Trace Mode = VIEW	M1 : 889.138 MHz : 29.623 dBm M2 : 6683.327 MHz : -33.995 dBm	Limit: 9.62 dBm Margin: -43.61 dB

[Back to the Matrix](#)

This test report may be reproduced in full only. The document may only be updated by MiCOM Labs personnel. Any changes will be noted in the Document History section of the report.



Title: Silver Spring Network MicroAP
To: FCC 47 CFR Part15.247 & IC RSS-210
Serial #: SSNT62-U2 Rev A
Issue Date: 13th August 2013
Page: 125 of 147



CONDUCTED SPURIOUS EMISSIONS - PEAK

Variants: FHSS, Channel: 915.00 MHz, Chain a, Temp: Ambient, Voltage: 4 Vdc

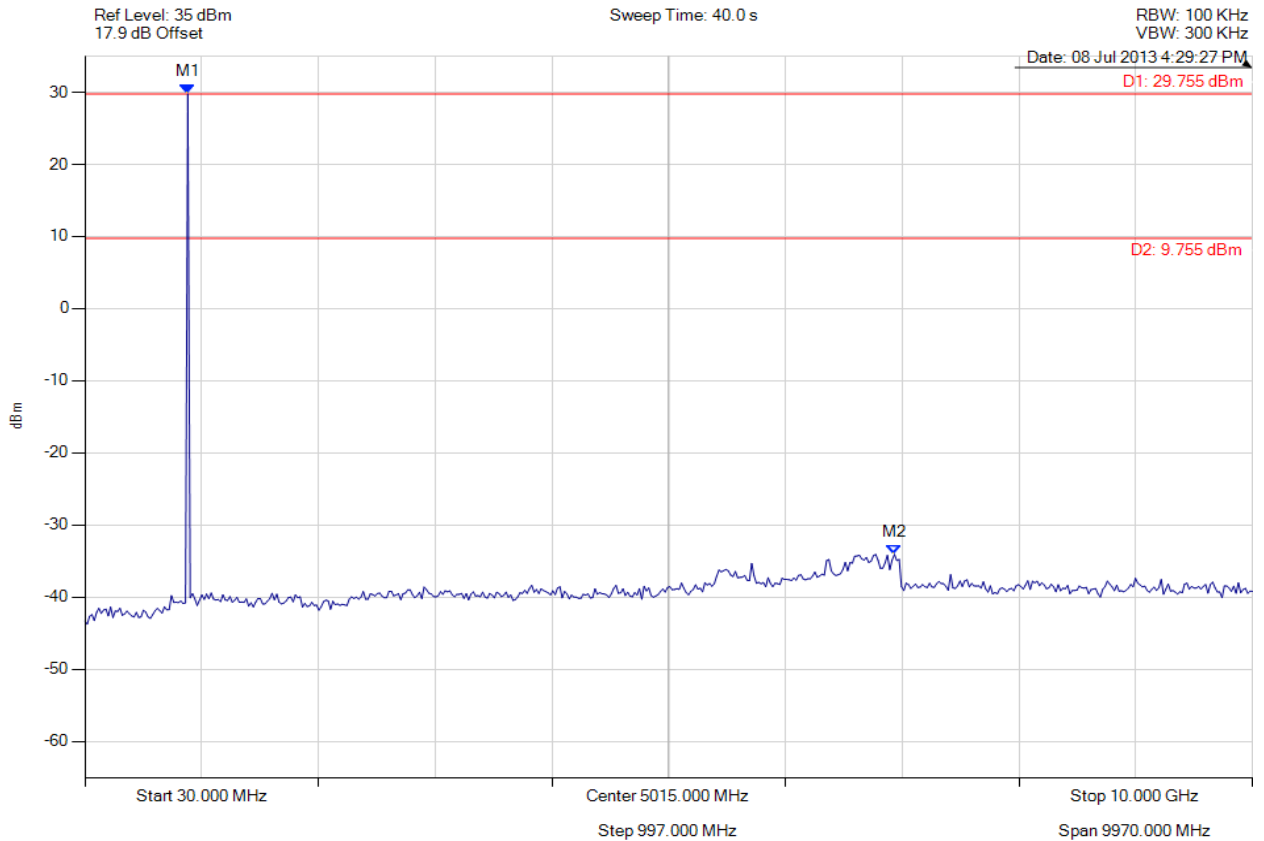

Analyser Setup	Marker : Frequency : Amplitude	Test Results
Detector = MAX PEAK Sweep Count = 0 RF Atten (dB) = 30 Trace Mode = VIEW	M1 : 909.118 MHz : 29.755 dBm M2 : 6943.066 MHz : -34.078 dBm	Limit: 9.76 dBm Margin: -43.84 dB

[Back to the Matrix](#)

This test report may be reproduced in full only. The document may only be updated by MiCOM Labs personnel. Any changes will be noted in the Document History section of the report.



Title: Silver Spring Network MicroAP
To: FCC 47 CFR Part15.247 & IC RSS-210
Serial #: SSNT62-U2 Rev A
Issue Date: 13th August 2013
Page: 126 of 147



CONDUCTED SPURIOUS EMISSIONS - PEAK

Variants: FHSS, Channel: 927.80 MHz, Chain a, Temp: Ambient, Voltage: 4 Vdc

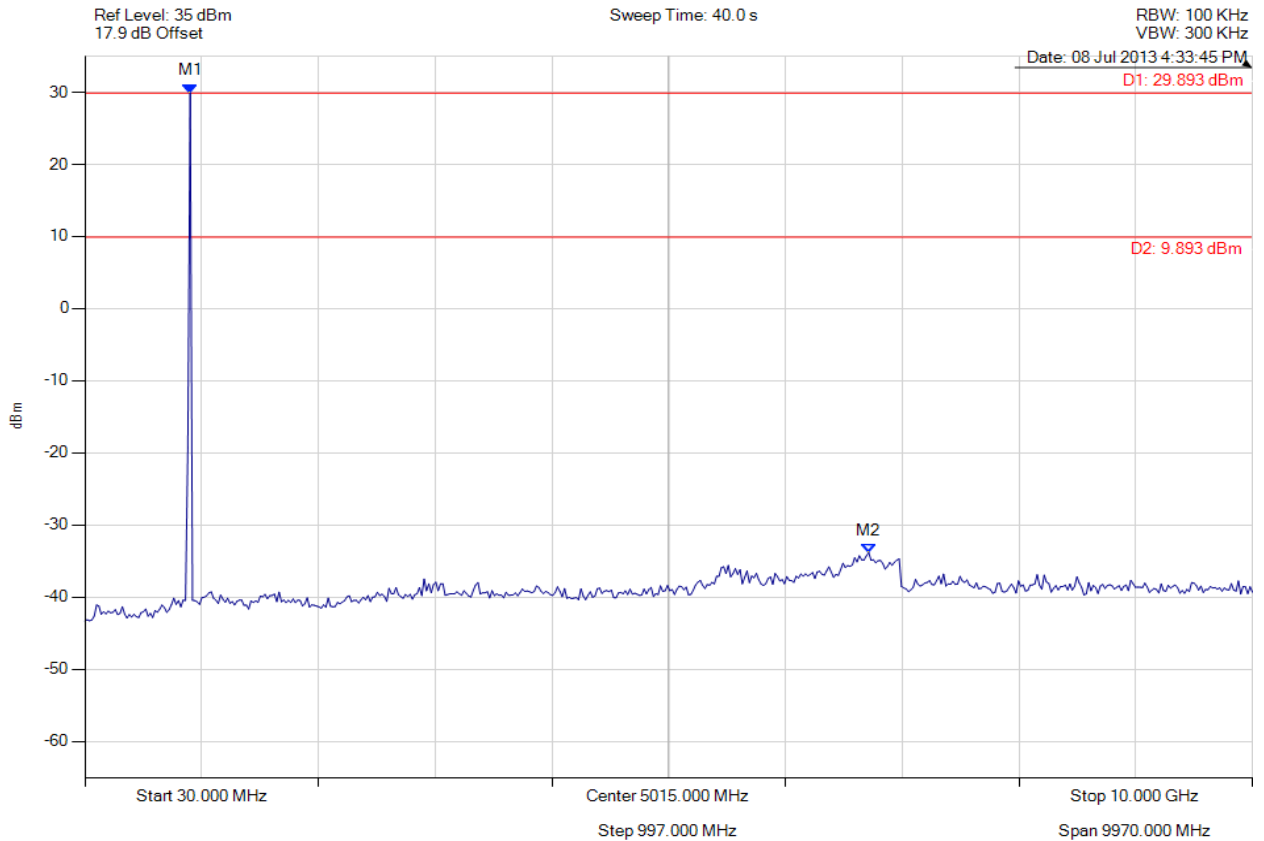

Analyser Setup	Marker : Frequency : Amplitude	Test Results
Detector = MAX PEAK Sweep Count = 0 RF Atten (dB) = 30 Trace Mode = VIEW	M1 : 929.098 MHz : 29.893 dBm M2 : 6723.287 MHz : -33.834 dBm	Limit: 9.89 dBm Margin: -43.72 dB

[Back to the Matrix](#)

This test report may be reproduced in full only. The document may only be updated by MiCOM Labs personnel. Any changes will be noted in the Document History section of the report.



Title: Silver Spring Network MicroAP
To: FCC 47 CFR Part15.247 & IC RSS-210
Serial #: SSNT62-U2 Rev A
Issue Date: 13th August 2013
Page: 127 of 147



CONDUCTED HIGH BAND-EDGE EMISSIONS - PEAK

Variation: FHSS, Channel: 902.30 MHz, Chain a, Temp: Ambient, Voltage: 4 Vdc

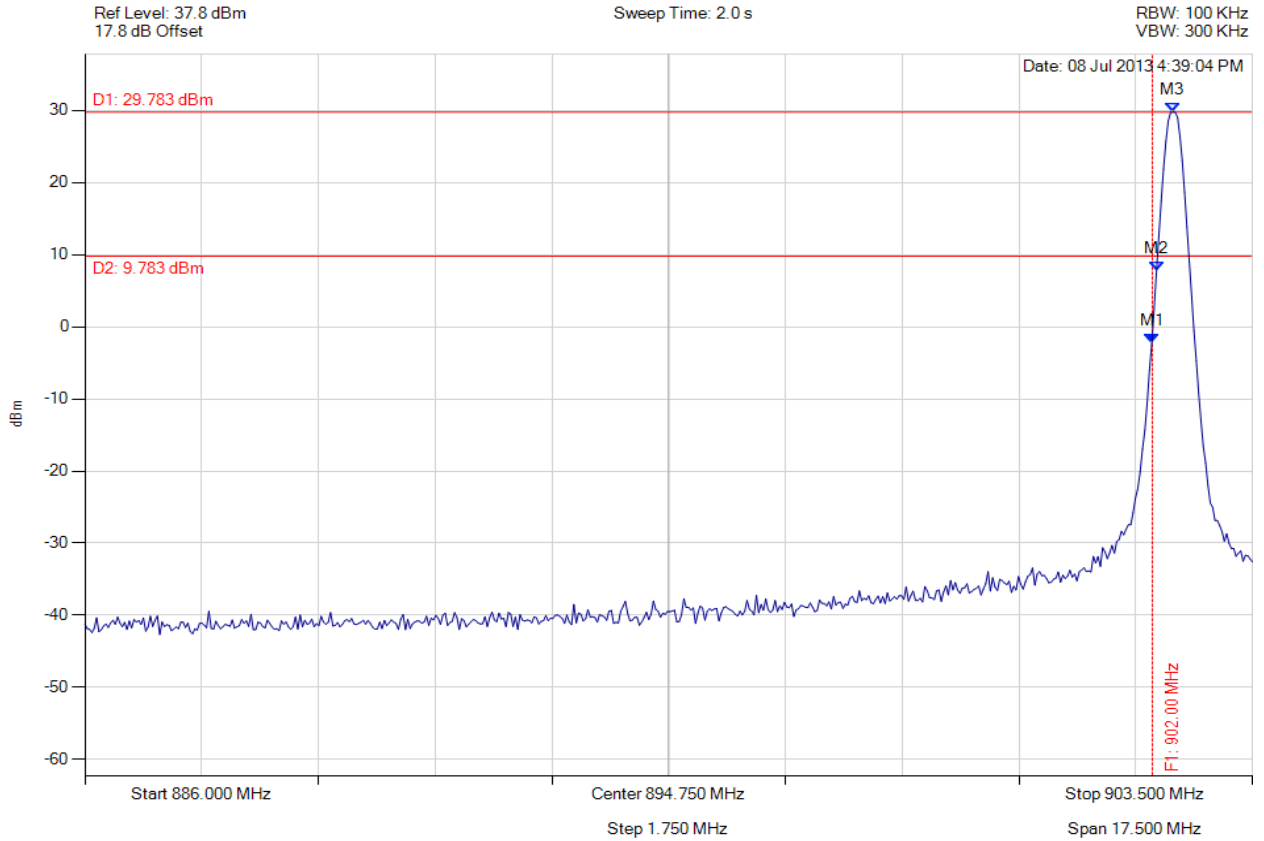

Analyser Setup	Marker : Frequency : Amplitude	Test Results
Detector = MAX PEAK Sweep Count = 0 RF Atten (dB) = 30 Trace Mode = VIEW	M1 : 902.000 MHz : -2.173 dBm M2 : 902.062 MHz : 7.833 dBm M3 : 902.308 MHz : 29.783 dBm	Limit: 9.78 dBm Margin: -11.95 dB

[Back to the Matrix](#)

This test report may be reproduced in full only. The document may only be updated by MiCOM Labs personnel. Any changes will be noted in the Document History section of the report.



Title: Silver Spring Network MicroAP
To: FCC 47 CFR Part15.247 & IC RSS-210
Serial #: SSNT62-U2 Rev A
Issue Date: 13th August 2013
Page: 128 of 147



CONDUCTED HIGH BAND-EDGE EMISSIONS - PEAK

Variant: FHSS, Channel: 927.50 MHz, Chain a, Temp: Ambient, Voltage: 4 Vdc

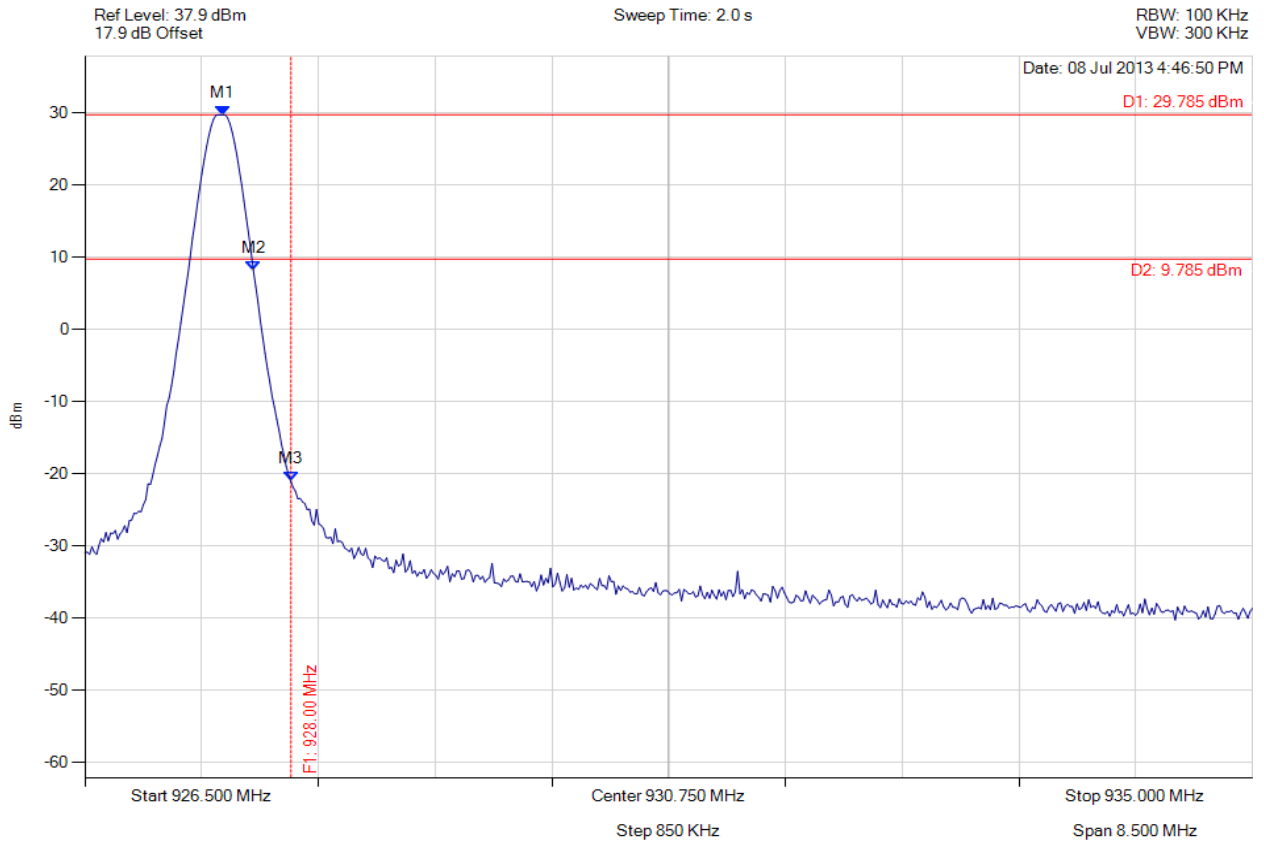

Analyser Setup	Marker : Frequency : Amplitude	Test Results
Detector = MAX PEAK Sweep Count = 0 RF Atten (dB) = 30 Trace Mode = VIEW	M1 : 927.505 MHz : 29.785 dBm M2 : 927.726 MHz : 8.207 dBm M3 : 928.000 MHz : -21.018 dBm	Limit: 9.79 dBm Margin: -30.81 dB

[Back to the Matrix](#)

This test report may be reproduced in full only. The document may only be updated by MiCOM Labs personnel. Any changes will be noted in the Document History section of the report.



Title: Silver Spring Network MicroAP
To: FCC 47 CFR Part15.247 & IC RSS-210
Serial #: SSNT62-U2 Rev A
Issue Date: 13th August 2013
Page: 129 of 147



CONDUCTED SPURIOUS EMISSIONS - PEAK

Variants: FHSS, Channel: 902.30 MHz, Chain a, Temp: Ambient, Voltage: 4 Vdc

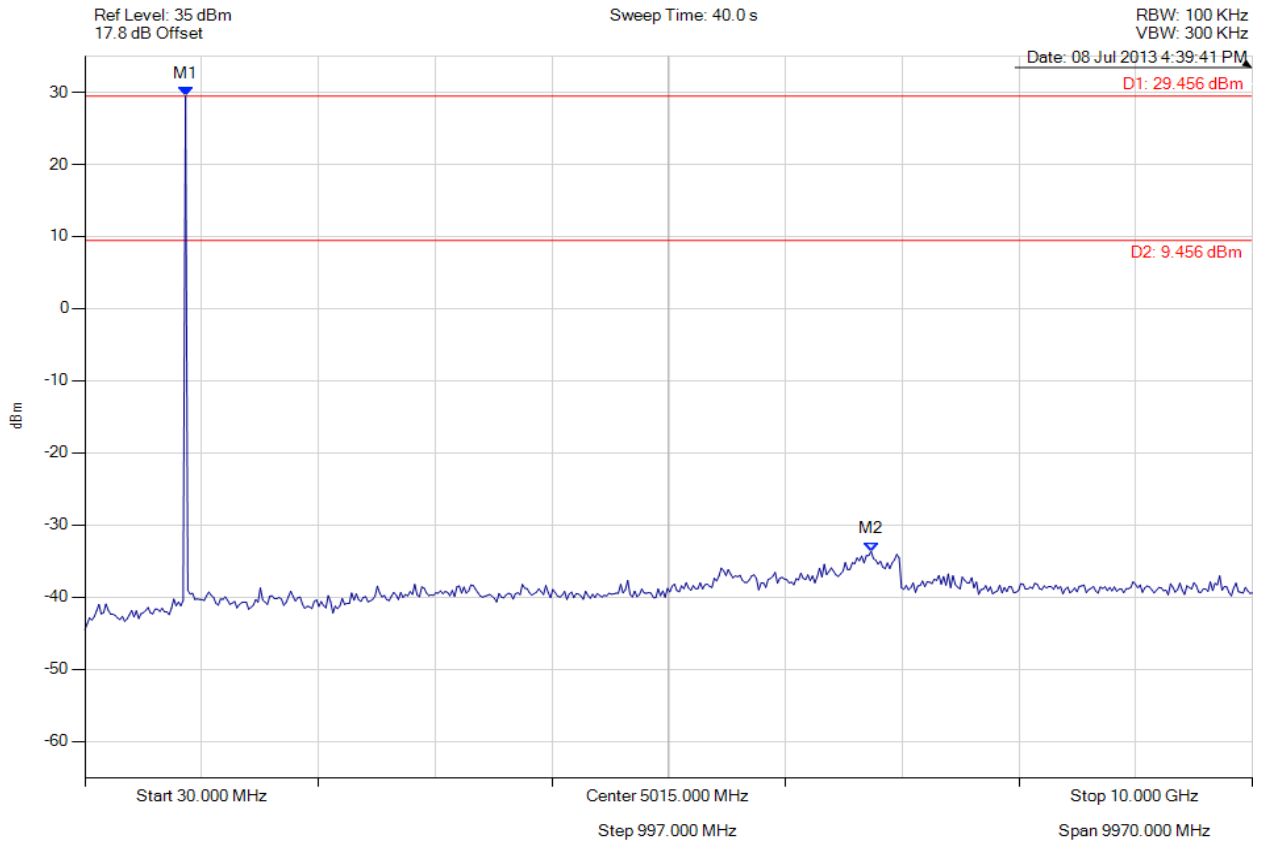

Analyser Setup	Marker : Frequency : Amplitude	Test Results
Detector = MAX PEAK Sweep Count = 0 RF Atten (dB) = 30 Trace Mode = VIEW	M1 : 889.138 MHz : 29.456 dBm M2 : 6743.267 MHz : -33.647 dBm	Limit: 9.46 dBm Margin: -43.11 dB

[Back to the Matrix](#)

This test report may be reproduced in full only. The document may only be updated by MiCOM Labs personnel. Any changes will be noted in the Document History section of the report.



Title: Silver Spring Network MicroAP
To: FCC 47 CFR Part15.247 & IC RSS-210
Serial #: SSNT62-U2 Rev A
Issue Date: 13th August 2013
Page: 130 of 147



CONDUCTED SPURIOUS EMISSIONS - PEAK

Variants: FHSS, Channel: 915.20 MHz, Chain a, Temp: Ambient, Voltage: 4 Vdc

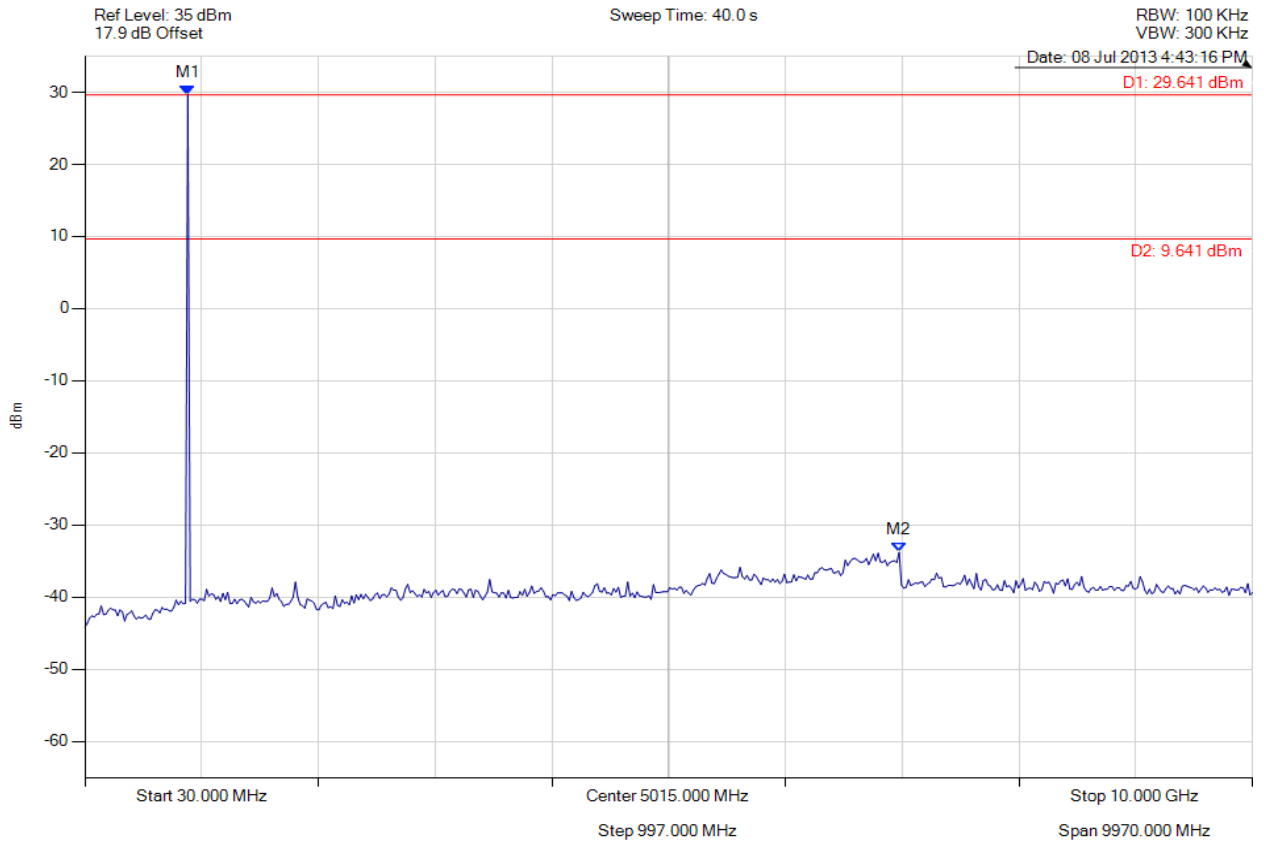

Analyser Setup	Marker : Frequency : Amplitude	Test Results
Detector = MAX PEAK Sweep Count = 0 RF Atten (dB) = 30 Trace Mode = VIEW	M1 : 909.118 MHz : 29.641 dBm M2 : 6983.026 MHz : -33.787 dBm	Limit: 9.64 dBm Margin: -43.43 dB

[Back to the Matrix](#)

This test report may be reproduced in full only. The document may only be updated by MiCOM Labs personnel. Any changes will be noted in the Document History section of the report.



Title: Silver Spring Network MicroAP
To: FCC 47 CFR Part15.247 & IC RSS-210
Serial #: SSNT62-U2 Rev A
Issue Date: 13th August 2013
Page: 131 of 147



CONDUCTED SPURIOUS EMISSIONS - PEAK

Variants: FHSS, Channel: 927.50 MHz, Chain a, Temp: Ambient, Voltage: 4 Vdc

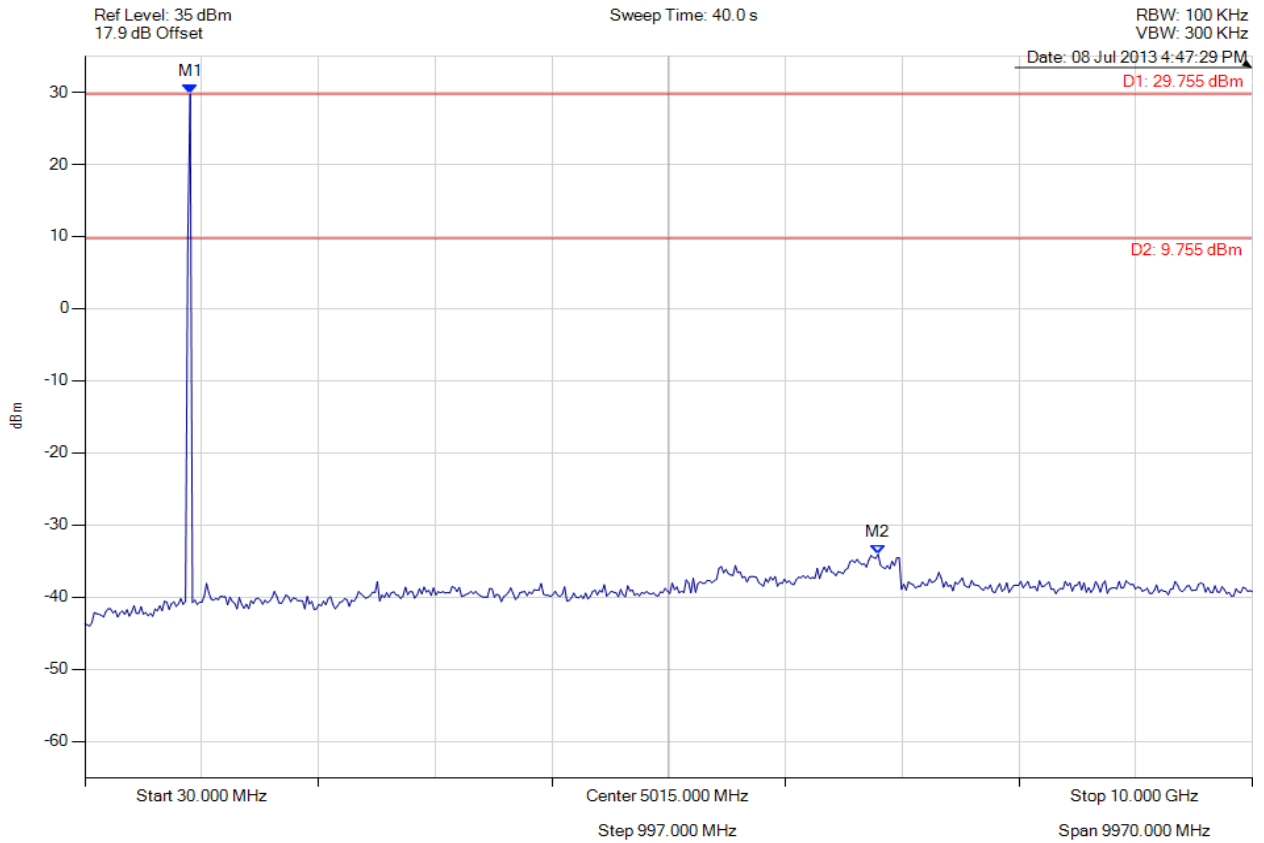

Analyser Setup	Marker : Frequency : Amplitude	Test Results
Detector = MAX PEAK Sweep Count = 0 RF Atten (dB) = 30 Trace Mode = VIEW	M1 : 929.098 MHz : 29.755 dBm M2 : 6803.206 MHz : -34.072 dBm	Limit: 9.76 dBm Margin: -43.83 dB

[Back to the Matrix](#)

This test report may be reproduced in full only. The document may only be updated by MiCOM Labs personnel. Any changes will be noted in the Document History section of the report.



Title: Silver Spring Network MicroAP
To: FCC 47 CFR Part15.247 & IC RSS-210
Serial #: SSNT62-U2 Rev A
Issue Date: 13th August 2013
Page: 132 of 147



CONDUCTED HIGH BAND-EDGE EMISSIONS - PEAK

Variant: FHSS, Channel: 902.40 MHz, Chain a, Temp: Ambient, Voltage: 4 Vdc

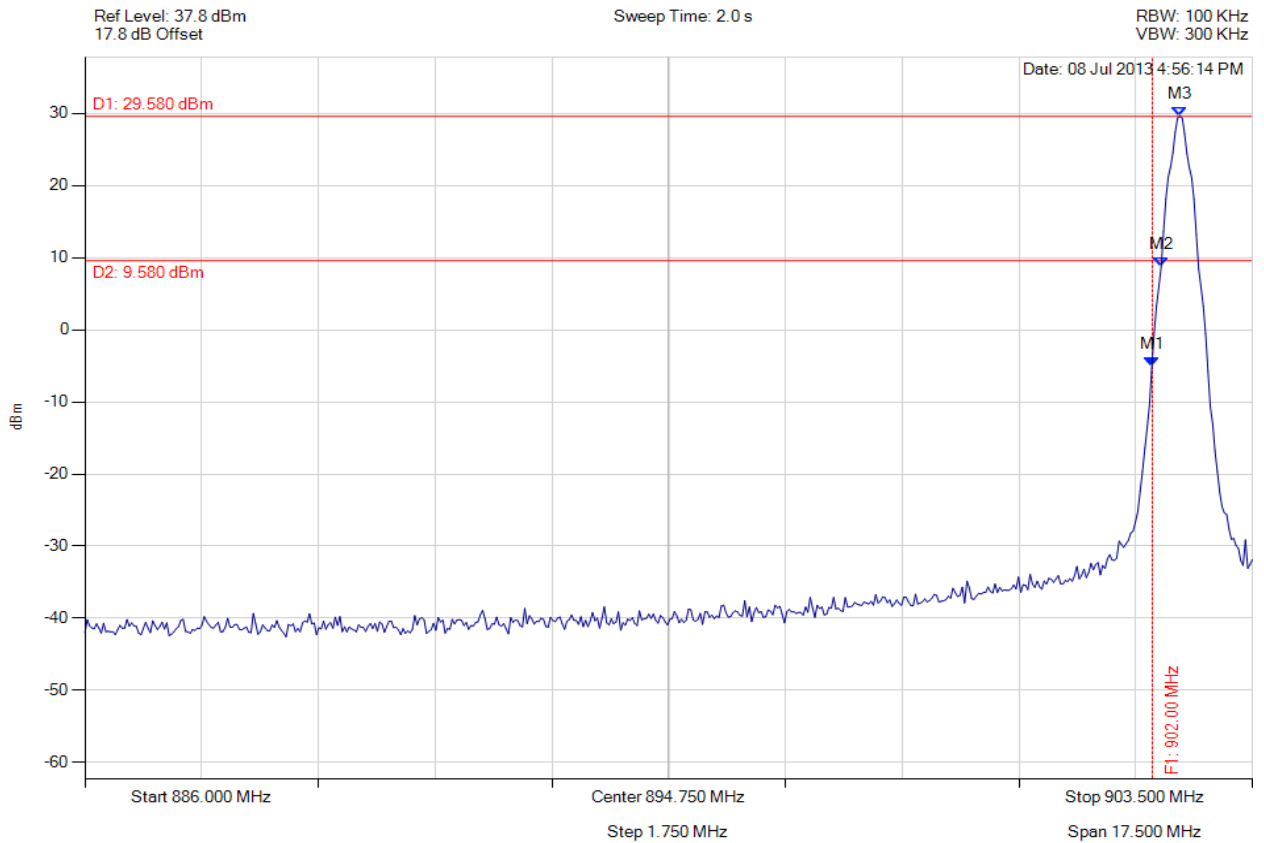

Analyser Setup	Marker : Frequency : Amplitude	Test Results
Detector = MAX PEAK Sweep Count = 0 RF Atten (dB) = 30 Trace Mode = VIEW	M1 : 902.000 MHz : -5.132 dBm M2 : 902.132 MHz : 8.801 dBm M3 : 902.413 MHz : 29.580 dBm	Limit: 9.58 dBm Margin: -14.71 dB

[Back to the Matrix](#)

This test report may be reproduced in full only. The document may only be updated by MiCOM Labs personnel. Any changes will be noted in the Document History section of the report.



Title: Silver Spring Network MicroAP
To: FCC 47 CFR Part15.247 & IC RSS-210
Serial #: SSNT62-U2 Rev A
Issue Date: 13th August 2013
Page: 133 of 147



CONDUCTED HIGH BAND-EDGE EMISSIONS - PEAK

Variant: FHSS, Channel: 927.60 MHz, Chain a, Temp: Ambient, Voltage: 4 Vdc

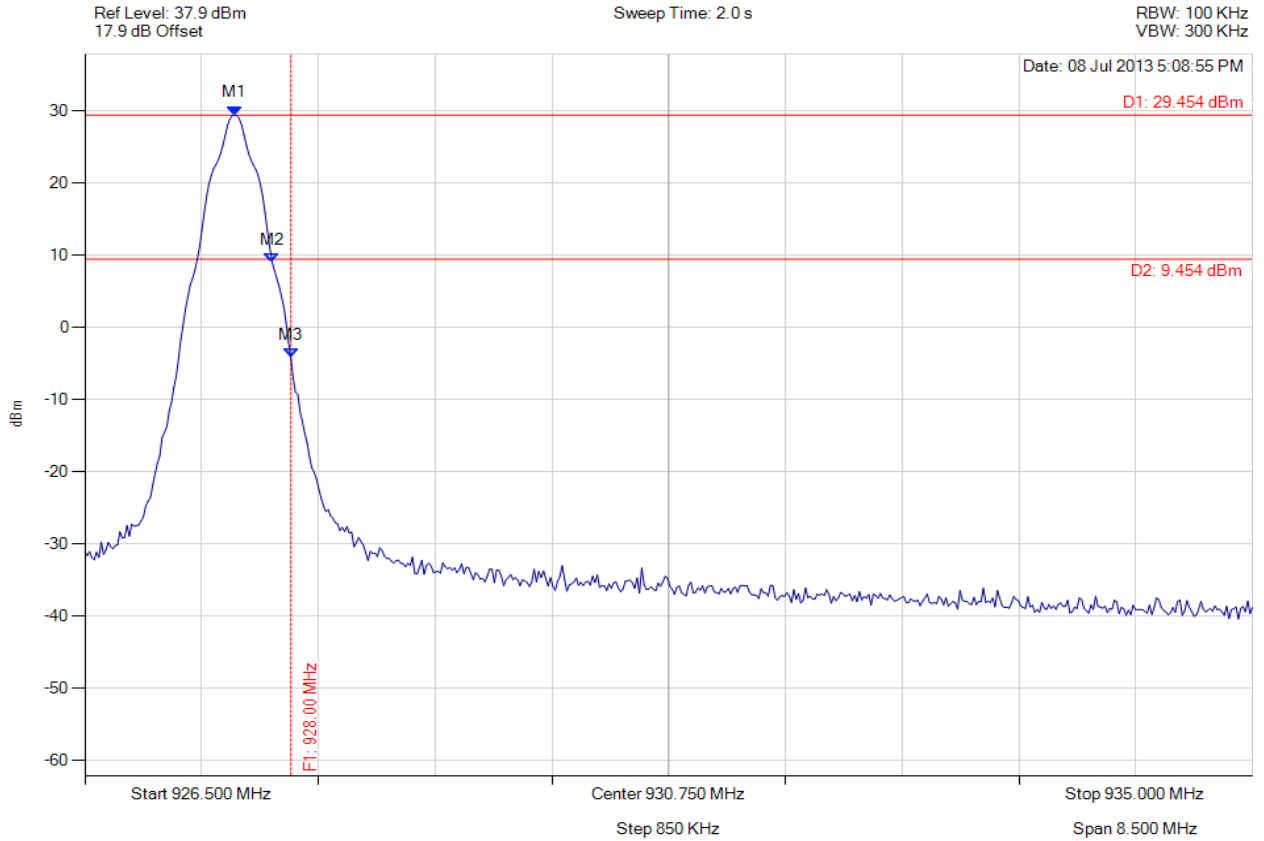

Analyser Setup	Marker : Frequency : Amplitude	Test Results
Detector = MAX PEAK Sweep Count = 0 RF Atten (dB) = 30 Trace Mode = VIEW	M1 : 927.590 MHz : 29.454 dBm M2 : 927.863 MHz : 9.092 dBm M3 : 928.000 MHz : -4.093 dBm	Limit: 9.45 dBm Margin: -13.54 dB

[Back to the Matrix](#)

This test report may be reproduced in full only. The document may only be updated by MiCOM Labs personnel. Any changes will be noted in the Document History section of the report.



Title: Silver Spring Network MicroAP
To: FCC 47 CFR Part15.247 & IC RSS-210
Serial #: SSNT62-U2 Rev A
Issue Date: 13th August 2013
Page: 134 of 147



CONDUCTED SPURIOUS EMISSIONS - PEAK

Variants: FHSS, Channel: 902.40 MHz, Chain a, Temp: Ambient, Voltage: 4 Vdc

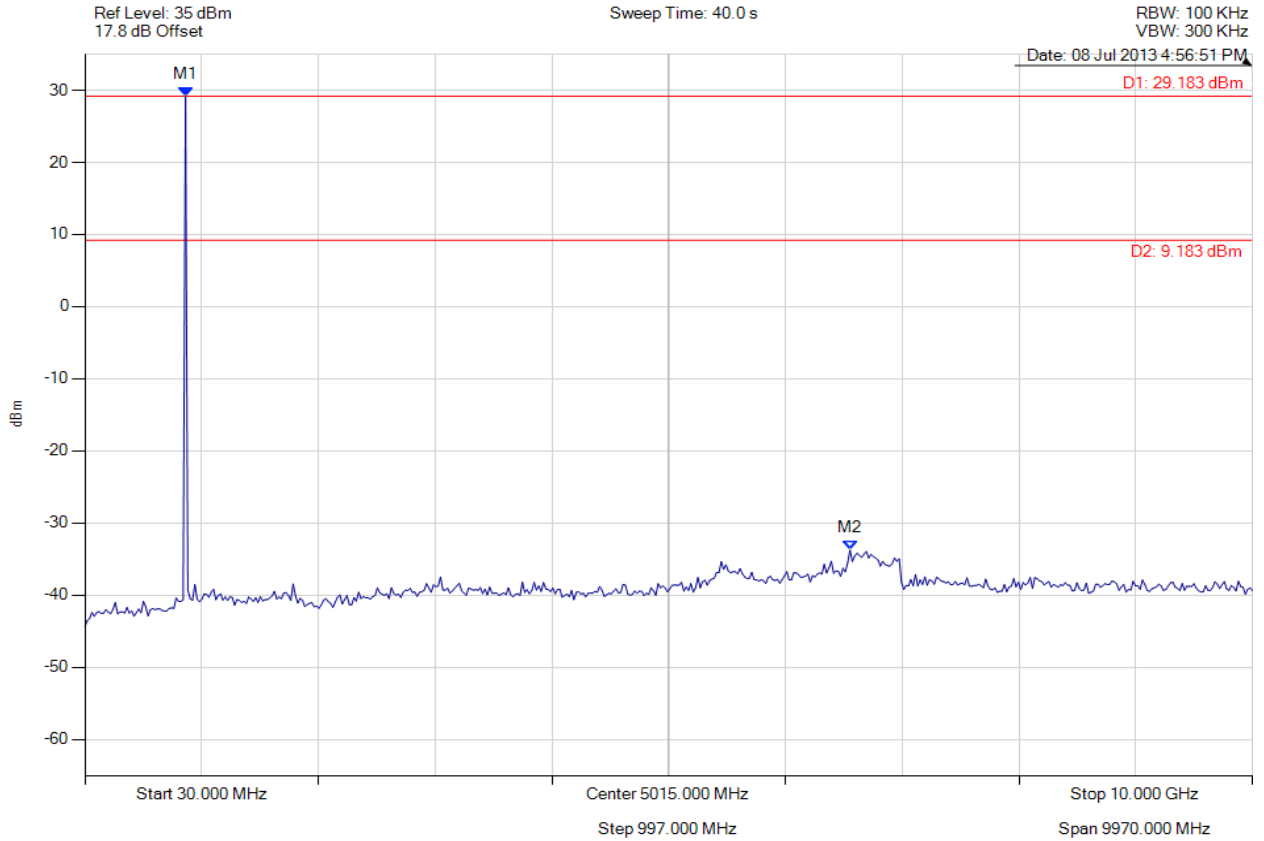

Analyser Setup	Marker : Frequency : Amplitude	Test Results
Detector = MAX PEAK Sweep Count = 0 RF Atten (dB) = 30 Trace Mode = VIEW	M1 : 889.138 MHz : 29.183 dBm M2 : 6563.447 MHz : -33.757 dBm	Limit: 9.18 dBm Margin: -42.94 dB

[Back to the Matrix](#)

This test report may be reproduced in full only. The document may only be updated by MiCOM Labs personnel. Any changes will be noted in the Document History section of the report.



Title: Silver Spring Network MicroAP
To: FCC 47 CFR Part15.247 & IC RSS-210
Serial #: SSNT62-U2 Rev A
Issue Date: 13th August 2013
Page: 135 of 147



CONDUCTED SPURIOUS EMISSIONS - PEAK

Variants: FHSS, Channel: 915.20 MHz, Chain a, Temp: Ambient, Voltage: 4 Vdc

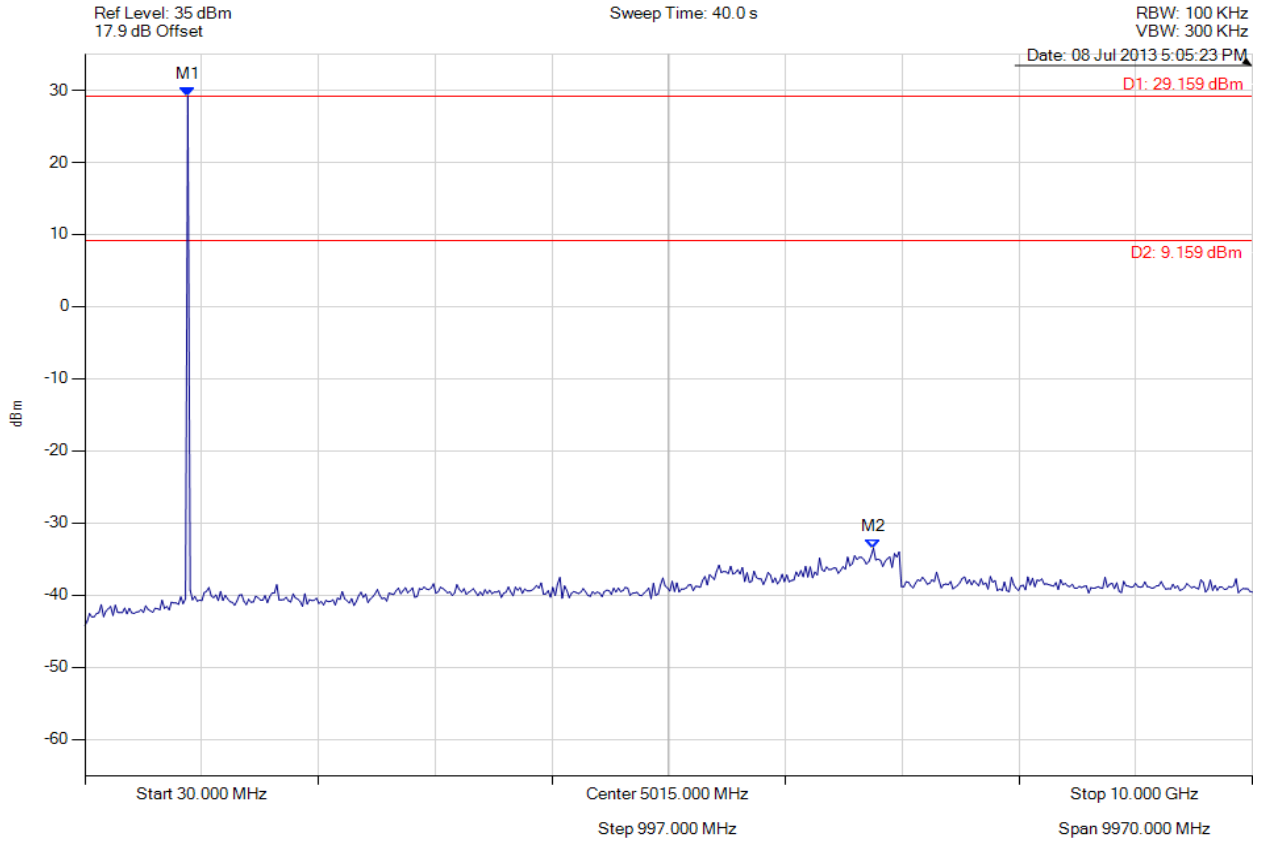

Analyser Setup	Marker : Frequency : Amplitude	Test Results
Detector = MAX PEAK Sweep Count = 0 RF Atten (dB) = 30 Trace Mode = VIEW	M1 : 909.118 MHz : 29.159 dBm M2 : 6763.246 MHz : -33.492 dBm	Limit: 9.16 dBm Margin: -42.65 dB

[Back to the Matrix](#)

This test report may be reproduced in full only. The document may only be updated by MiCOM Labs personnel. Any changes will be noted in the Document History section of the report.



Title: Silver Spring Network MicroAP
To: FCC 47 CFR Part15.247 & IC RSS-210
Serial #: SSNT62-U2 Rev A
Issue Date: 13th August 2013
Page: 136 of 147



CONDUCTED SPURIOUS EMISSIONS - PEAK

Variant: FHSS, Channel: 927.60 MHz, Chain a, Temp: Ambient, Voltage: 4 Vdc

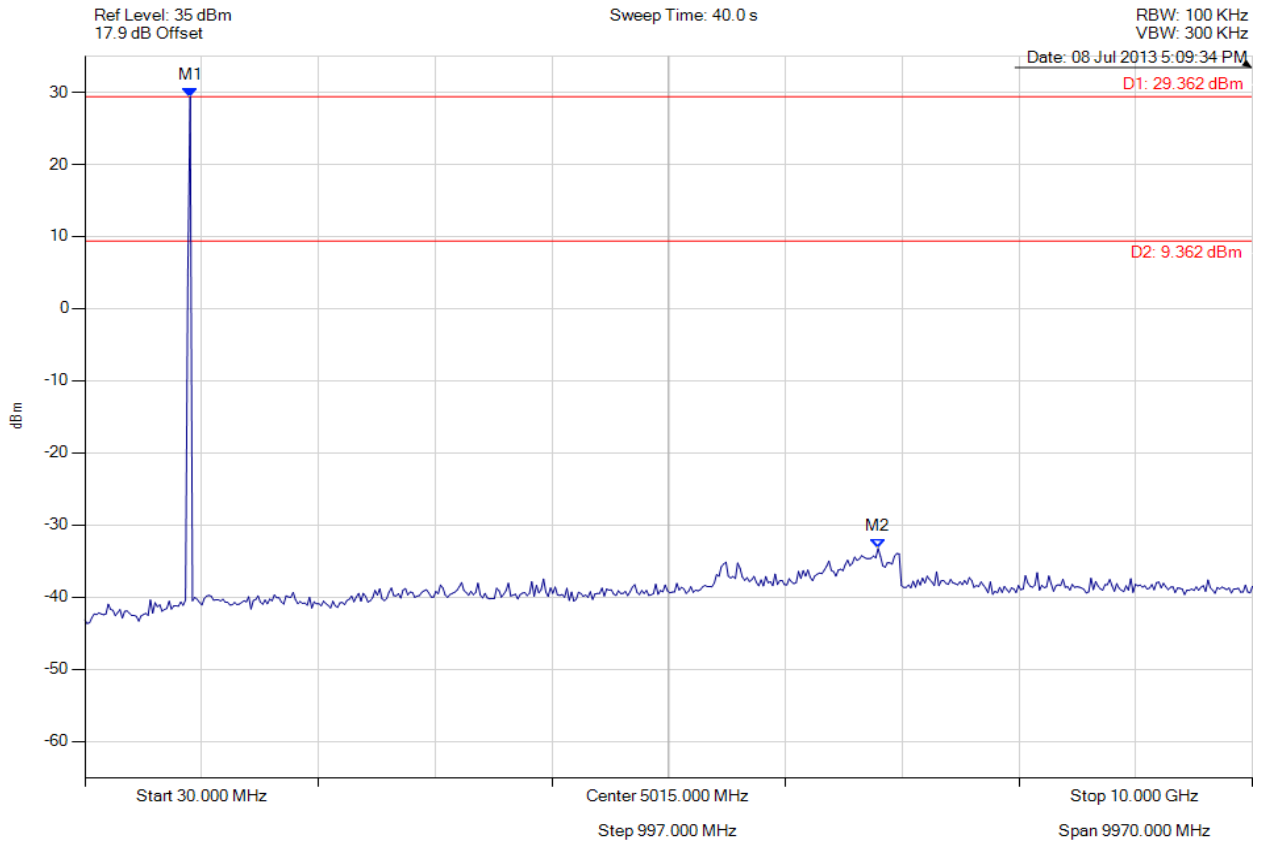

Analyser Setup	Marker : Frequency : Amplitude	Test Results
Detector = MAX PEAK Sweep Count = 0 RF Atten (dB) = 30 Trace Mode = VIEW	M1 : 929.098 MHz : 29.362 dBm M2 : 6803.206 MHz : -33.244 dBm	Limit: 9.36 dBm Margin: -42.60 dB

[Back to the Matrix](#)

This test report may be reproduced in full only. The document may only be updated by MiCOM Labs personnel. Any changes will be noted in the Document History section of the report.



Title: Silver Spring Network MicroAP
To: FCC 47 CFR Part15.247 & IC RSS-210
Serial #: SSNT62-U2 Rev A
Issue Date: 13th August 2013
Page: 137 of 147



CONDUCTED HIGH BAND-EDGE EMISSIONS - PEAK

Variant: FHSS, Channel: 2400.80 MHz, Chain a, Temp: Ambient, Voltage: 4 Vdc

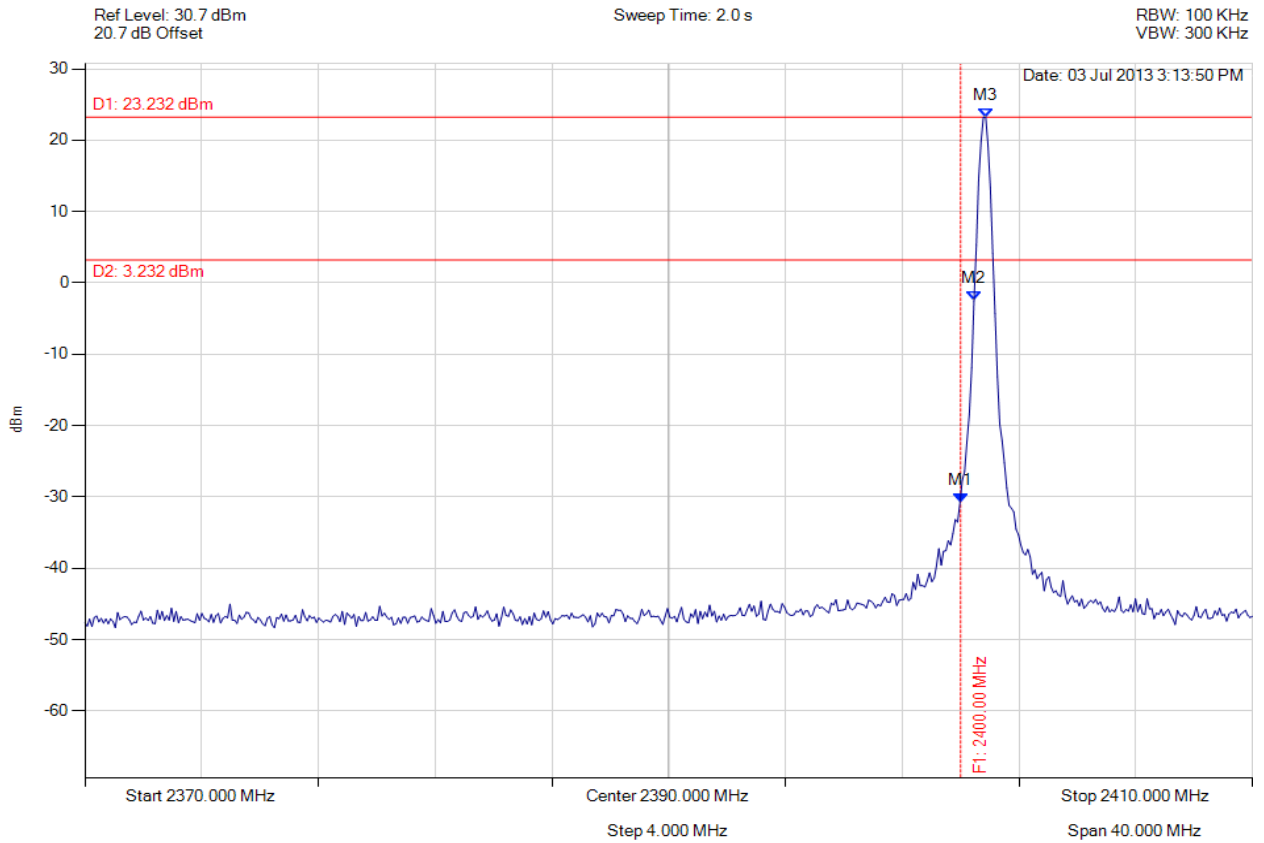

Analyser Setup	Marker : Frequency : Amplitude	Test Results
Detector = MAX PEAK Sweep Count = 0 RF Atten (dB) = 20 Trace Mode = VIEW	M1 : 2400.000 MHz : -30.748 dBm M2 : 2400.461 MHz : -2.521 dBm M3 : 2400.862 MHz : 23.232 dBm	Limit: 3.23 dBm Margin: -33.98 dB

[Back to the Matrix](#)

This test report may be reproduced in full only. The document may only be updated by MiCOM Labs personnel. Any changes will be noted in the Document History section of the report.



Title: Silver Spring Network MicroAP
To: FCC 47 CFR Part15.247 & IC RSS-210
Serial #: SSNT62-U2 Rev A
Issue Date: 13th August 2013
Page: 138 of 147



CONDUCTED HIGH BAND-EDGE EMISSIONS - PEAK

Variant: FHSS, Channel: 2472.80 MHz, Chain a, Temp: Ambient, Voltage: 4 Vdc

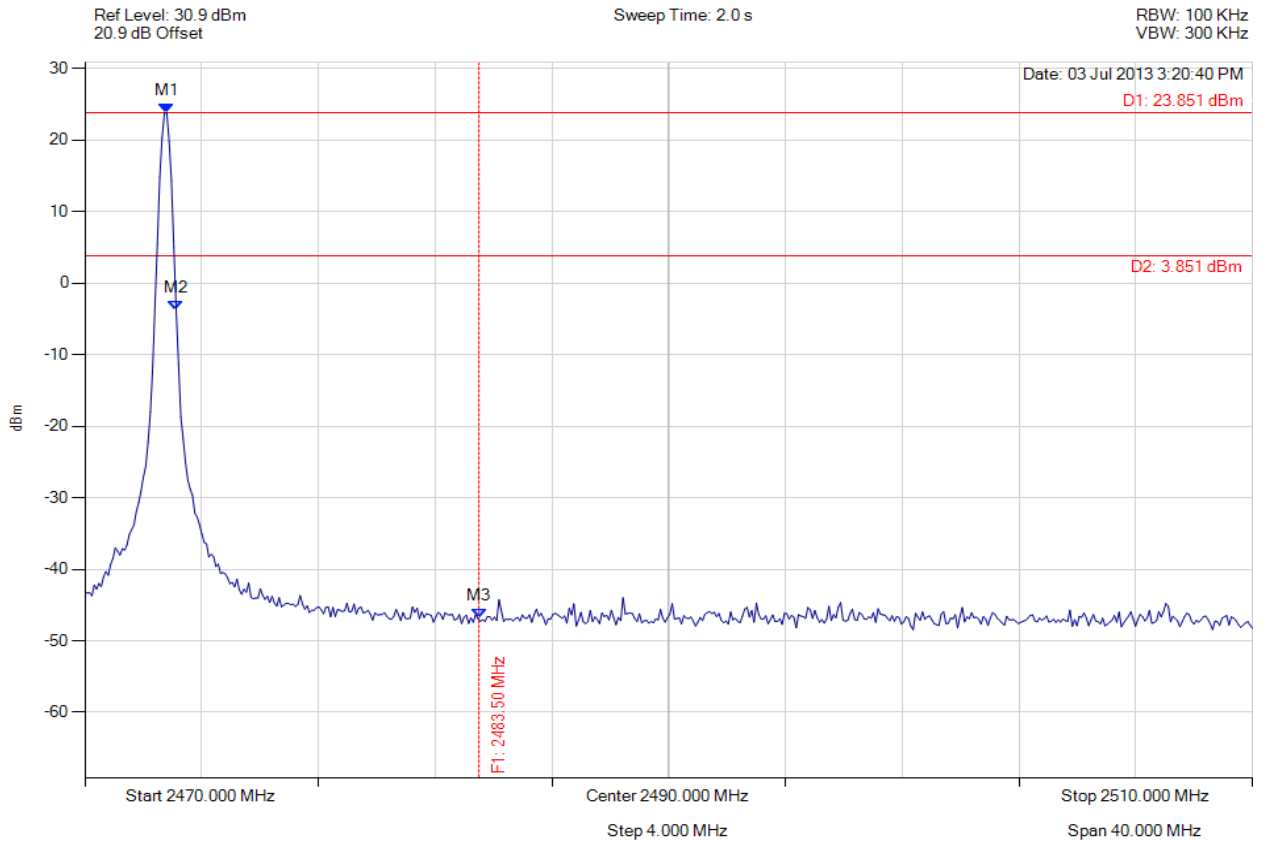

Analyser Setup	Marker : Frequency : Amplitude	Test Results
Detector = MAX PEAK Sweep Count = 0 RF Atten (dB) = 20 Trace Mode = VIEW	M1 : 2472.806 MHz : 23.851 dBm M2 : 2473.126 MHz : -3.684 dBm M3 : 2483.500 MHz : -46.887 dBm	Limit: 3.85 dBm Margin: -50.74 dB

[Back to the Matrix](#)

This test report may be reproduced in full only. The document may only be updated by MiCOM Labs personnel. Any changes will be noted in the Document History section of the report.



Title: Silver Spring Network MicroAP
To: FCC 47 CFR Part15.247 & IC RSS-210
Serial #: SSNT62-U2 Rev A
Issue Date: 13th August 2013
Page: 139 of 147



CONDUCTED SPURIOUS EMISSIONS - PEAK

Variant: FHSS, Channel: 2400.80 MHz, Chain a, Temp: Ambient, Voltage: 4 Vdc

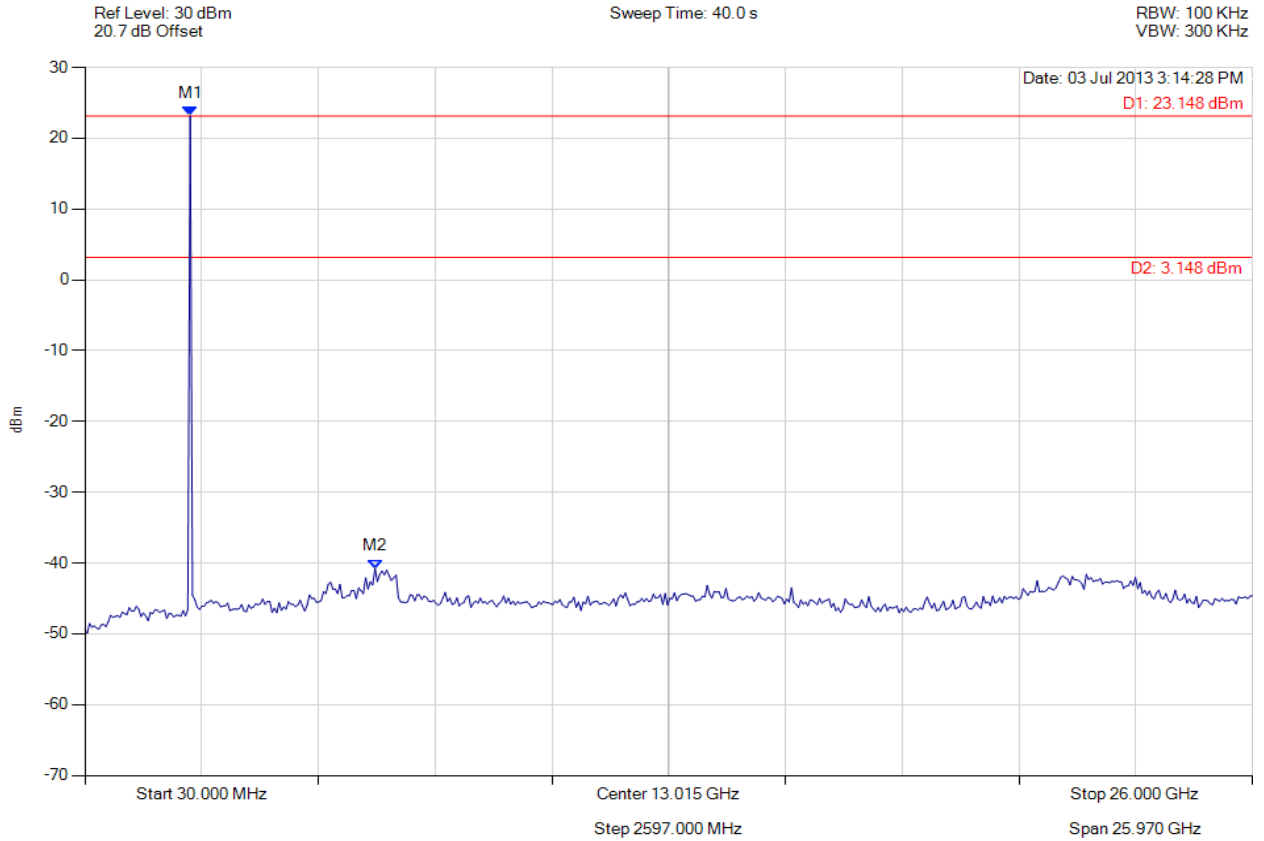

Analyser Setup	Marker : Frequency : Amplitude	Test Results
Detector = MAX PEAK Sweep Count = 0 RF Atten (dB) = 20 Trace Mode = VIEW	M1 : 2371.984 MHz : 23.148 dBm M2 : 6483.467 MHz : -40.776 dBm	Limit: 3.15 dBm Margin: -43.93 dB

[Back to the Matrix](#)

This test report may be reproduced in full only. The document may only be updated by MiCOM Labs personnel. Any changes will be noted in the Document History section of the report.



Title: Silver Spring Network MicroAP
To: FCC 47 CFR Part15.247 & IC RSS-210
Serial #: SSNT62-U2 Rev A
Issue Date: 13th August 2013
Page: 140 of 147



CONDUCTED SPURIOUS EMISSIONS - PEAK

Variant: FHSS, Channel: 2440.00 MHz, Chain a, Temp: Ambient, Voltage: 4 Vdc

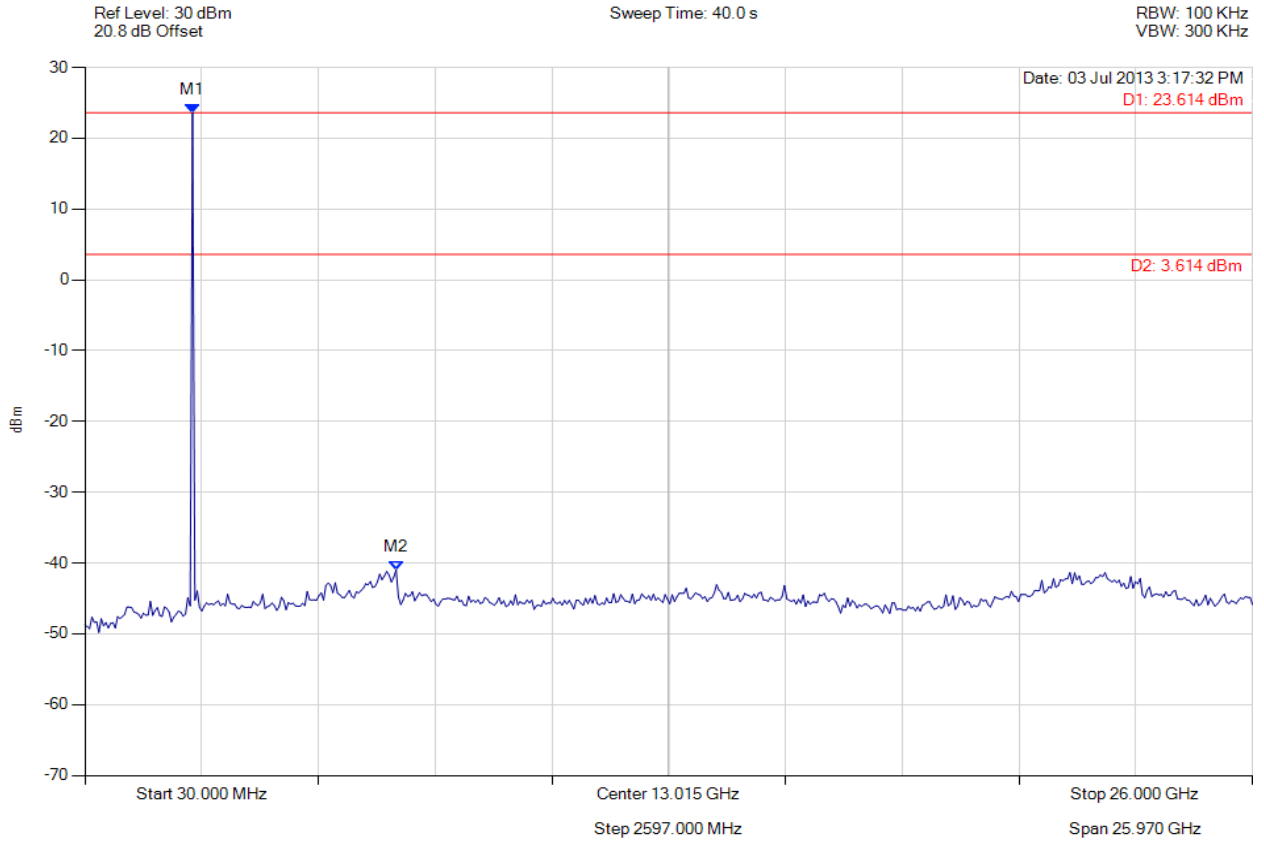

Analyser Setup	Marker : Frequency : Amplitude	Test Results
Detector = MAX PEAK Sweep Count = 0 RF Atten (dB) = 20 Trace Mode = VIEW	M1 : 2424.028 MHz : 23.614 dBm M2 : 6951.864 MHz : -40.951 dBm	Limit: 3.61 dBm Margin: -44.56 dB

[Back to the Matrix](#)

This test report may be reproduced in full only. The document may only be updated by MiCOM Labs personnel. Any changes will be noted in the Document History section of the report.



Title: Silver Spring Network MicroAP
To: FCC 47 CFR Part15.247 & IC RSS-210
Serial #: SSNT62-U2 Rev A
Issue Date: 13th August 2013
Page: 141 of 147



CONDUCTED SPURIOUS EMISSIONS - PEAK

Variant: FHSS, Channel: 2472.80 MHz, Chain a, Temp: Ambient, Voltage: 4 Vdc

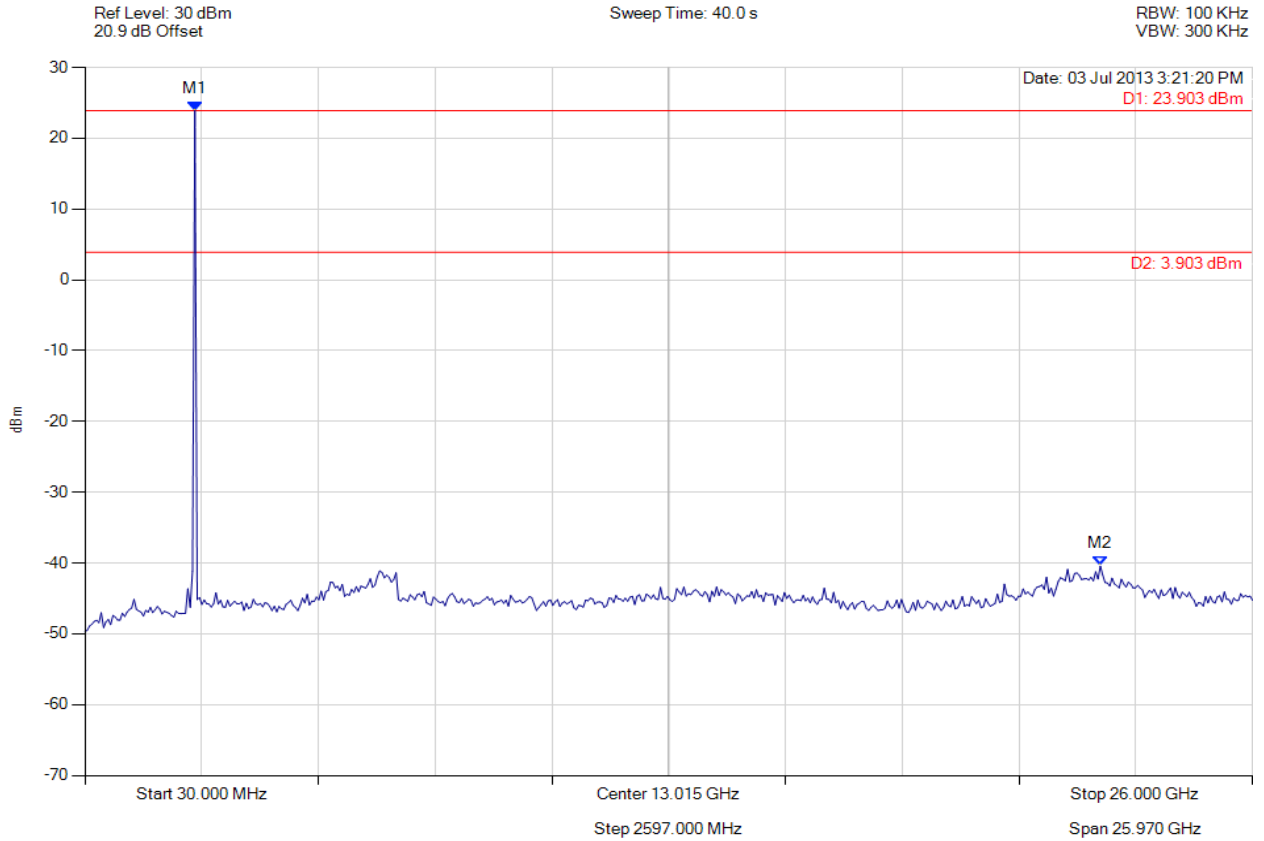

Analyser Setup	Marker : Frequency : Amplitude	Test Results
Detector = MAX PEAK Sweep Count = 0 RF Atten (dB) = 20 Trace Mode = VIEW	M1 : 2476.072 MHz : 23.903 dBm M2 : 22.617 GHz : -40.433 dBm	Limit: 3.90 dBm Margin: -44.33 dB

[Back to the Matrix](#)

This test report may be reproduced in full only. The document may only be updated by MiCOM Labs personnel. Any changes will be noted in the Document History section of the report.



Title: Silver Spring Network MicroAP
To: FCC 47 CFR Part15.247 & IC RSS-210
Serial #: SSNT62-U2 Rev A
Issue Date: 13th August 2013
Page: 142 of 147



CONDUCTED HIGH BAND-EDGE EMISSIONS - PEAK

Variant: FHSS, Channel: 2400.80 MHz, Chain a, Temp: Ambient, Voltage: 4 Vdc

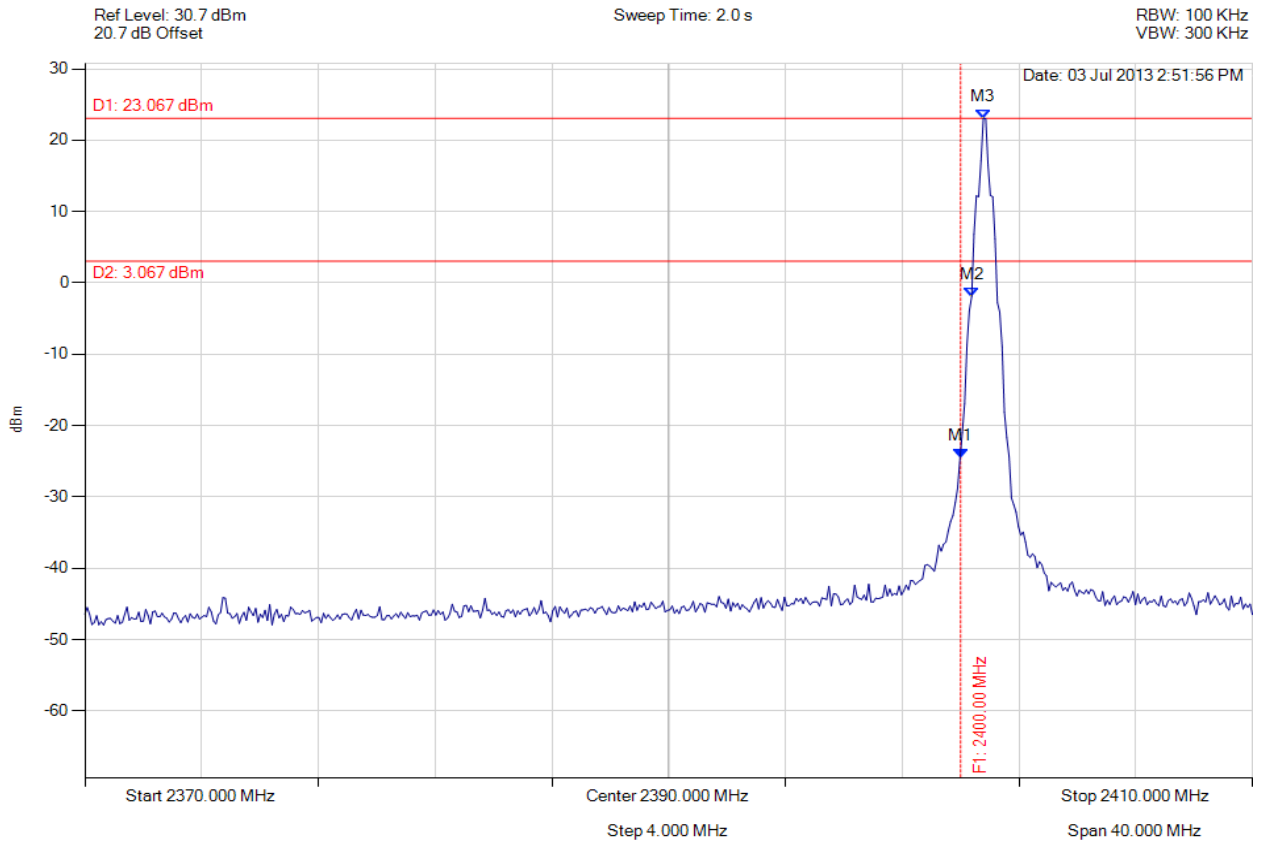

Analyser Setup	Marker : Frequency : Amplitude	Test Results
Detector = MAX PEAK Sweep Count = 0 RF Atten (dB) = 20 Trace Mode = VIEW	M1 : 2400.000 MHz : -24.585 dBm M2 : 2400.381 MHz : -1.917 dBm M3 : 2400.782 MHz : 23.067 dBm	Limit: 3.07 dBm Margin: -27.66 dB

[Back to the Matrix](#)

This test report may be reproduced in full only. The document may only be updated by MiCOM Labs personnel. Any changes will be noted in the Document History section of the report.



Title: Silver Spring Network MicroAP
To: FCC 47 CFR Part15.247 & IC RSS-210
Serial #: SSNT62-U2 Rev A
Issue Date: 13th August 2013
Page: 143 of 147



CONDUCTED HIGH BAND-EDGE EMISSIONS - PEAK

Variant: FHSS, Channel: 2472.80 MHz, Chain a, Temp: Ambient, Voltage: 4 Vdc

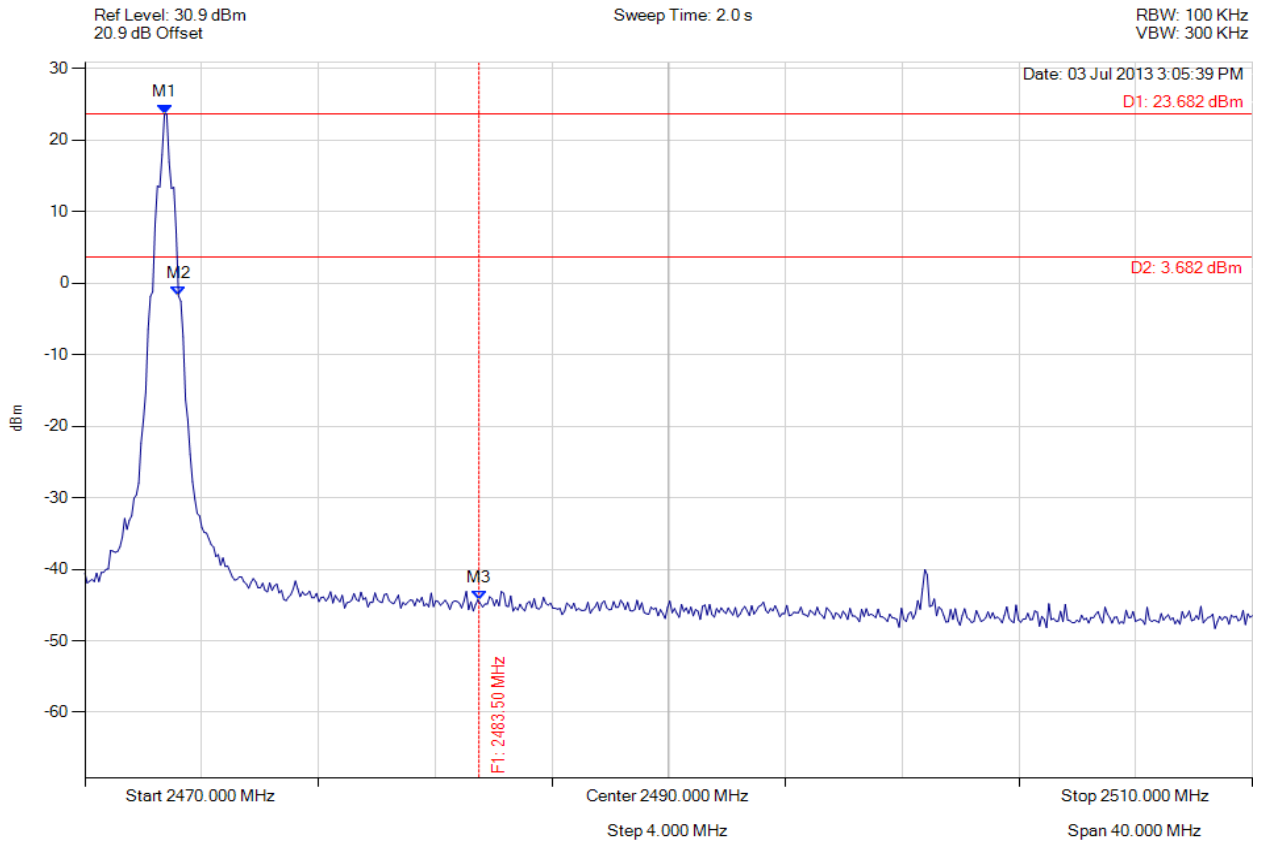

Analyser Setup	Marker : Frequency : Amplitude	Test Results
Detector = MAX PEAK Sweep Count = 0 RF Atten (dB) = 20 Trace Mode = VIEW	M1 : 2472.725 MHz : 23.682 dBm M2 : 2473.206 MHz : -1.780 dBm M3 : 2483.500 MHz : -44.261 dBm	Limit: 3.68 dBm Margin: -47.94 dB

[Back to the Matrix](#)

This test report may be reproduced in full only. The document may only be updated by MiCOM Labs personnel. Any changes will be noted in the Document History section of the report.



Title: Silver Spring Network MicroAP
To: FCC 47 CFR Part15.247 & IC RSS-210
Serial #: SSNT62-U2 Rev A
Issue Date: 13th August 2013
Page: 144 of 147



CONDUCTED SPURIOUS EMISSIONS - PEAK

Variant: FHSS, Channel: 2400.80 MHz, Chain a, Temp: Ambient, Voltage: 4 Vdc

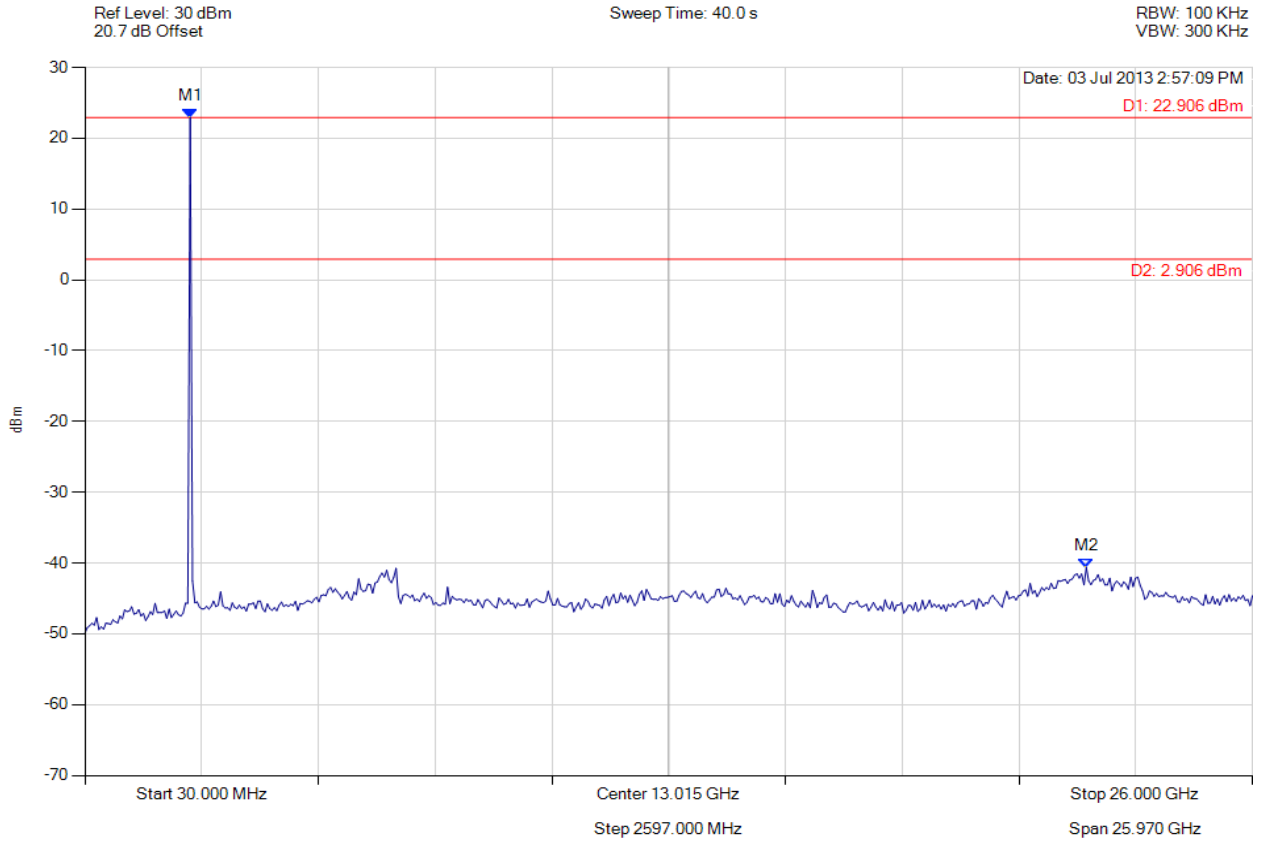

Analyser Setup	Marker : Frequency : Amplitude	Test Results
Detector = MAX PEAK Sweep Count = 0 RF Atten (dB) = 20 Trace Mode = VIEW	M1 : 2371.984 MHz : 22.906 dBm M2 : 22.305 GHz : -40.636 dBm	Limit: 2.91 dBm Margin: -43.55 dB

[Back to the Matrix](#)

This test report may be reproduced in full only. The document may only be updated by MiCOM Labs personnel. Any changes will be noted in the Document History section of the report.



Title: Silver Spring Network MicroAP
To: FCC 47 CFR Part15.247 & IC RSS-210
Serial #: SSNT62-U2 Rev A
Issue Date: 13th August 2013
Page: 145 of 147



CONDUCTED SPURIOUS EMISSIONS - PEAK

Variant: FHSS, Channel: 2440.00 MHz, Chain a, Temp: Ambient, Voltage: 4 Vdc

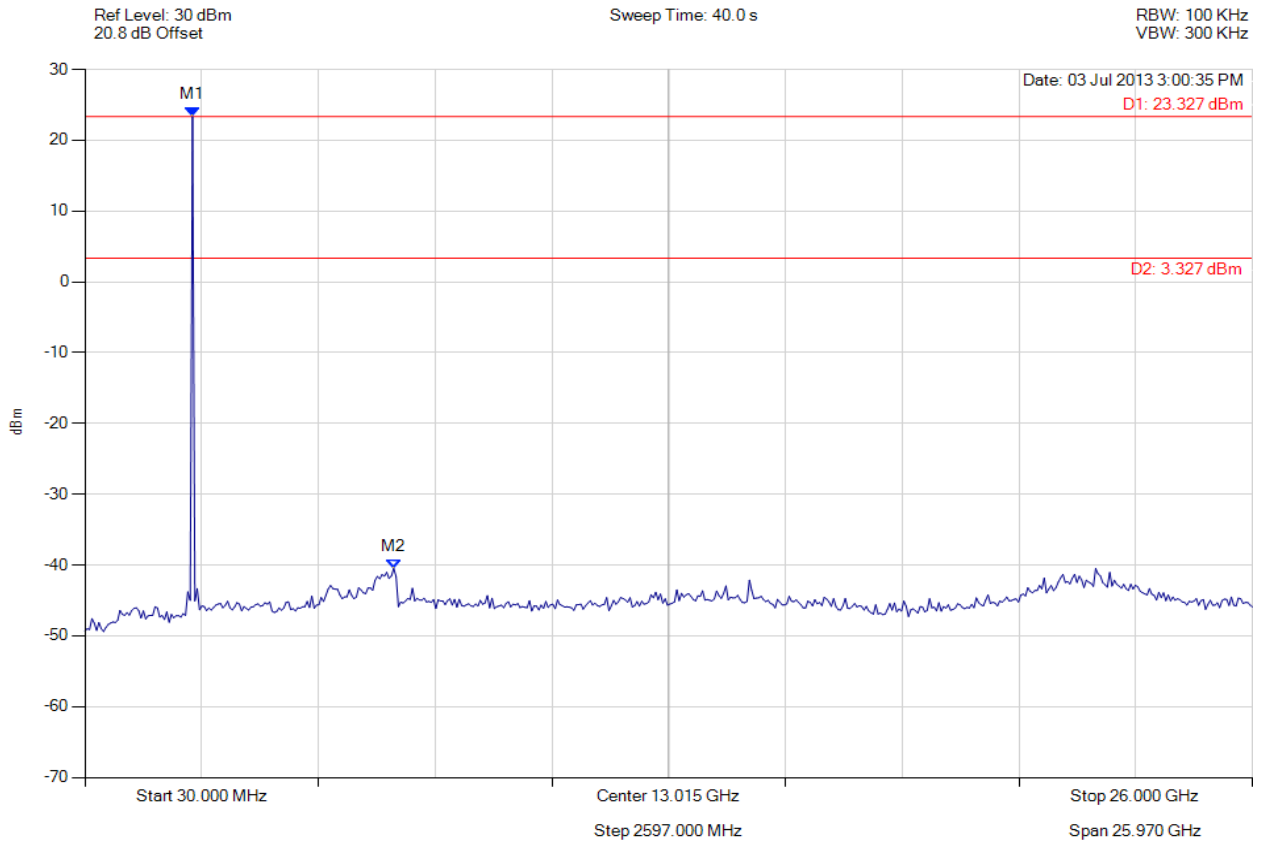

Analyser Setup	Marker : Frequency : Amplitude	Test Results
Detector = MAX PEAK Sweep Count = 0 RF Atten (dB) = 20 Trace Mode = VIEW	M1 : 2424.028 MHz : 23.327 dBm M2 : 6899.820 MHz : -40.469 dBm	Limit: 3.33 dBm Margin: -43.80 dB

[Back to the Matrix](#)

This test report may be reproduced in full only. The document may only be updated by MiCOM Labs personnel. Any changes will be noted in the Document History section of the report.



Title: Silver Spring Network MicroAP
To: FCC 47 CFR Part15.247 & IC RSS-210
Serial #: SSNT62-U2 Rev A
Issue Date: 13th August 2013
Page: 146 of 147



CONDUCTED SPURIOUS EMISSIONS - PEAK

Variant: FHSS, Channel: 2472.80 MHz, Chain a, Temp: Ambient, Voltage: 4 Vdc

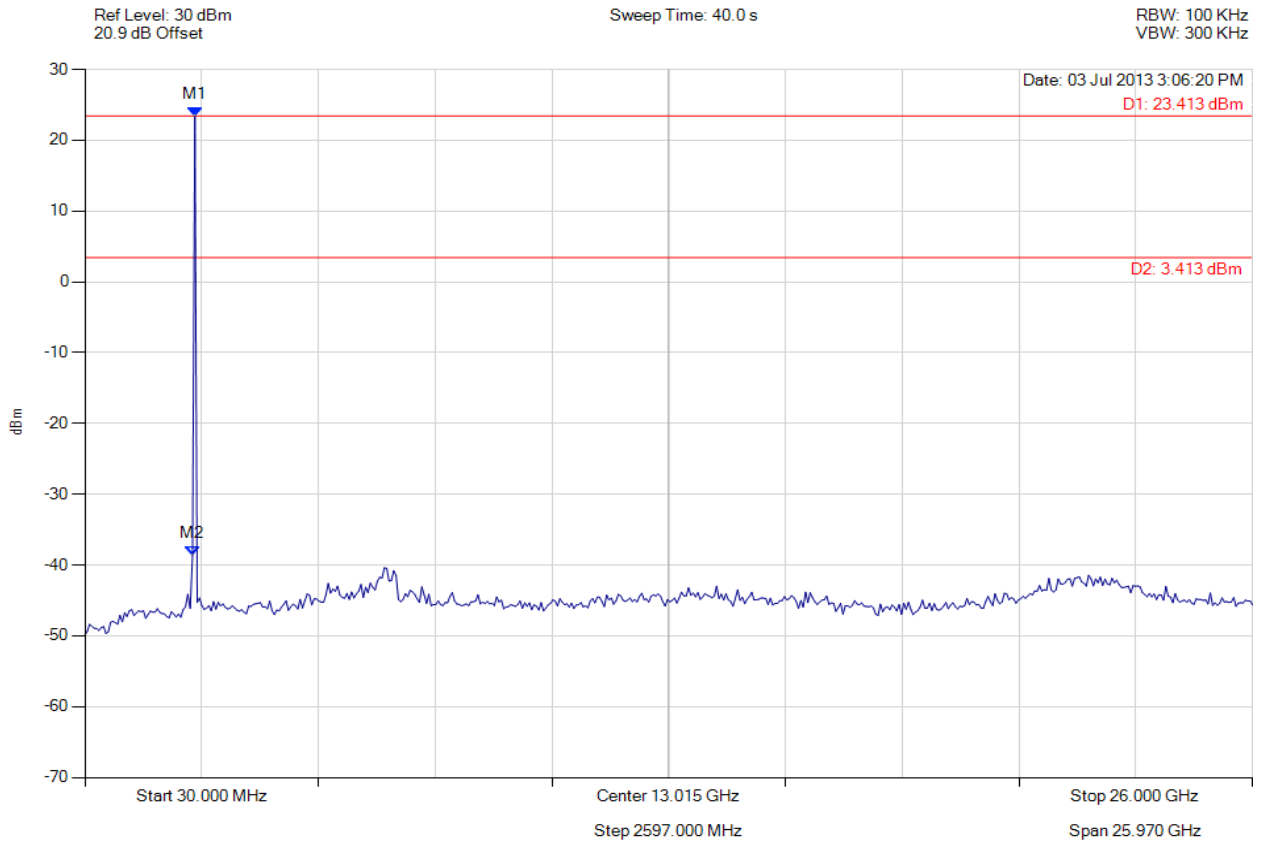

Analyser Setup	Marker : Frequency : Amplitude	Test Results
Detector = MAX PEAK Sweep Count = 0 RF Atten (dB) = 20 Trace Mode = VIEW	M1 : 2476.072 MHz : 23.413 dBm M2 : 2424.028 MHz : -38.732 dBm	Limit: 3.41 dBm Margin: -42.14 dB

[Back to the Matrix](#)

This test report may be reproduced in full only. The document may only be updated by MiCOM Labs personnel. Any changes will be noted in the Document History section of the report.



440 Boulder Court, Suite 200
Pleasanton, CA 94566, USA
Tel: 1.925.462.0304
Fax: 1.925.462.0306
www.micomlabs.com