

Company: Silver Spring Networks

Test of: Milli™ 5  
To: FCC 15.247 RSS 247 (DTS)

Report No.: SSNT122-U2\_Master Rev A

**CONDUCTED TEST REPORT**



# MASTER TEST REPORT

FROM



Test of: Silver Spring Networks Milli™ 5  
to

To: FCC CFR 47 Part 15 Subpart C 15.247 & IC RSS 247

Test Report Serial No.: SSNT122-U2\_Master Rev A

This report supersedes: NONE

This document is the Master document controlling Addendum reports as listed below. This Master document combined with the Addendums demonstrate compliance with the standard

Master Document Number	Addendum Reports
SSNT122-U2_Master	SSNT122-U2_Conducted
	SSNT122-U2_Radiated

Applicant: Silver Spring Networks  
230 W Tasman Dr  
San Jose, California 95134  
USA

Product Function: Modular Plug-in radio device, will  
communicate over 900 MHz.

Issue Date: 13th October 2016

## **This Test Report is Issued Under the Authority of:**

**MiCOM Labs, Inc.**  
575 Boulder Court  
Pleasanton California 94566  
USA  
Phone: +1 (925) 462-0304  
Fax: +1 (925) 462-0306  
[www.micomlabs.com](http://www.micomlabs.com)



**MiCOM Labs is an ISO 17025 Accredited Testing Laboratory**



**Title:** Silver Spring Networks Milli™ 5  
**To:** FCC 15.247 & RSS 247  
**Serial #:** SSNT122-U2\_Master Rev A  
**Issue Date:** 13th October 2016  
**Page:** 3 of 22

---

## Table of Contents

<b>1. ACCREDITATION, LISTINGS &amp; RECOGNITION.....</b>	<b>4</b>
1.1. TESTING ACCREDITATION.....	4
1.2. RECOGNITION .....	5
1.3. PRODUCT CERTIFICATION .....	6
<b>2. DOCUMENT HISTORY .....</b>	<b>7</b>
<b>3. TEST RESULT CERTIFICATE.....</b>	<b>8</b>
<b>4. REFERENCES AND MEASUREMENT UNCERTAINTY .....</b>	<b>9</b>
4.1. Normative References .....	9
4.2. Test and Uncertainty Procedure .....	10
<b>5. PRODUCT DETAILS AND TEST CONFIGURATIONS .....</b>	<b>11</b>
5.1. Technical Details .....	11
5.2. Scope Of Test Program .....	12
5.3. Equipment Model(s) and Serial Number(s) .....	14
5.4. Antenna Details .....	14
5.5. Cabling and I/O Ports .....	14
5.6. Test Configurations.....	15
5.7. Equipment Modifications .....	15
5.8. Deviations from the Test Standard .....	15
<b>6. TEST SUMMARY .....</b>	<b>16</b>
<b>7. TEST EQUIPMENT CONFIGURATION(S) .....</b>	<b>17</b>
7.1. Conducted .....	17
7.2. Radiated Emissions.....	19

---

This test report may be reproduced in full only. The document may only be updated by MiCOM Labs personnel. All changes will be noted in the Document History section of the report.

## 1. ACCREDITATION, LISTINGS & RECOGNITION

### 1.1. TESTING ACCREDITATION

MiCOM Labs, Inc. is an accredited Electrical testing laboratory per the international standard ISO/IEC 17025:2005. The company is accredited by the American Association for Laboratory Accreditation (A2LA) [www.a2la.org](http://www.a2la.org) test laboratory number 2381.01. MiCOM Labs test schedule is available at the following URL; <http://www.a2la.org/scopepdf/2381-01.pdf>



### Accredited Laboratory

A2LA has accredited

**MICOM LABS**

Pleasanton, CA

for technical competence in the field of

**Electrical Testing**

This laboratory is accredited in accordance with the recognized International Standard ISO/IEC 17025:2005 General requirements for the competence of testing and calibration laboratories. This accreditation demonstrates technical competence for a defined scope and the operation of a laboratory quality management system (refer to joint ISO-ILAC-IAF Communiqué dated 8 January 2009).



Presented this 4<sup>th</sup> day of February 2016.



Senior Director of Quality & Communications  
For the Accreditation Council  
Certificate Number 2381.01  
Valid to November 30, 2017

For the tests or types of tests to which this accreditation applies, please refer to the laboratory's Electrical Scope of Accreditation.

This test report may be reproduced in full only. The document may only be updated by MiCOM Labs personnel. All changes will be noted in the Document History section of the report.



## 1.2. RECOGNITION

MiCOM Labs, Inc has widely recognized wireless testing capabilities. Our international recognition includes Conformity Assessment Body designation by APEC MRA countries. MiCOM Labs test reports are accepted globally.

Country	Recognition Body	Status	Phase	Identification No.
USA	Federal Communications Commission (FCC)	TCB	-	US0159 Listing #: 102167
Canada	Industry Canada (IC)	FCB	APEC MRA 2	US0159 Listing #: 4143A-2 4143A-3
Japan	MIC (Ministry of Internal Affairs and Communication)	CAB	APEC MRA 2	RCB 210
	VCCI	--	--	A-0012
Europe	European Commission	NB	EU MRA	NB 2280
Australia	Australian Communications and Media Authority (ACMA)	CAB	APEC MRA 1	US0159
Hong Kong	Office of the Telecommunication Authority (OFTA)	CAB	APEC MRA 1	
Korea	Ministry of Information and Communication Radio Research Laboratory (RRL)	CAB	APEC MRA 1	
Singapore	Infocomm Development Authority (IDA)	CAB	APEC MRA 1	
Taiwan	National Communications Commission (NCC) Bureau of Standards, Metrology and Inspection (BSMI)	CAB	APEC MRA 1	
Vietnam	Ministry of Communication (MIC)	CAB	APEC MRA 1	

EU MRA – European Union Mutual Recognition Agreement.

NB – Notified Body

APEC MRA – Asia Pacific Economic Community Mutual Recognition Agreement. Recognition agreement under which test lab is accredited to regulatory standards of the APEC member countries.

Phase I - recognition for product testing

Phase II – recognition for both product testing and certification

### 1.3. PRODUCT CERTIFICATION

MiCOM Labs, Inc. is an accredited Product Certification Body per the international standard ISO/IEC 17065:2012. The company is accredited by the American Association for Laboratory Accreditation (A2LA) [www.a2la.org](http://www.a2la.org) test laboratory number 2381.02. MiCOM Labs test schedule is available at the following URL; <http://www.a2la.org/scopepdf/2381-02.pdf>



## Accredited Product Certification Body

A2LA has accredited

**MICOM LABS**

Pleasanton, CA

This product certification body is accredited in accordance with the recognized International Standard ISO/IEC 17065:2012 *Requirements for bodies certifying products, processes and services*. This accreditation demonstrates technical competence for a defined scope and the operation of a management system.



Presented this 4<sup>th</sup> day of February 2016.



Senior Director of Quality & Communications  
For the Accreditation Council  
Certificate Number 2381.02  
Valid to November 30, 2017

*For the product certification schemes to which this accreditation applies, please refer to the organization's Product Certification Scope of Accreditation.*

United States of America – Telecommunication Certification Body (TCB)

Industry Canada – Certification Body, CAB Identifier – US0159

Europe – Notified Body (NB), NB Identifier - 2280

Japan – Recognized Certification Body (RCB), RCB Identifier - 210

This test report may be reproduced in full only. The document may only be updated by MiCOM Labs personnel. All changes will be noted in the Document History section of the report.



**Title:** Silver Spring Networks Milli™ 5  
**To:** FCC 15.247 & RSS 247  
**Serial #:** SSNT122-U2\_Master Rev A  
**Issue Date:** 13th October 2016  
**Page:** 7 of 22

## 2. DOCUMENT HISTORY

Document History			
Document	Revision	Date	Comments
Master	Rev A	13 <sup>th</sup> October 2016	Initial release
Conducted Addendum	Rev A	13 <sup>th</sup> October 2016	Initial release
Radiated Addendum	Rev A	13 <sup>th</sup> October 2016	Initial release

This test report may be reproduced in full only. The document may only be updated by MiCOM Labs personnel. All changes will be noted in the Document History section of the report.



**Title:** Silver Spring Networks Milli™ 5  
**To:** FCC 15.247 & RSS 247  
**Serial #:** SSNT122-U2\_Master Rev A  
**Issue Date:** 13th October 2016  
**Page:** 8 of 22

### 3. TEST RESULT CERTIFICATE

<b>Manufacturer:</b> Silver Spring Networks 230 W Tasman Dr San Jose California 95134 USA	<b>Tested By:</b> MiCOM Labs, Inc. 575 Boulder Court Pleasanton California 94566 USA
<b>Model:</b> Milli™ 5	<b>Telephone:</b> +1 925 462 0304
<b>Type Of Equipment:</b> Modular Plug-in radio device, will communicate over 900 MHz.	<b>Fax:</b> +1 925 462 0306
<b>S/N's:</b> 00:13:50:05:00:22:87:9C	
<b>Test Date(s):</b> 30 <sup>th</sup> August to 6 <sup>th</sup> September 2016	<b>Website:</b> www.micomlabs.com

STANDARD(S)	TEST RESULTS
FCC CFR 47 Part 15 Subpart C 15.247 & IC RSS 247 (DTS)	EQUIPMENT COMPLIES

MiCOM Labs, Inc. tested the equipment mentioned in accordance with the requirements set forth in the above standards. Test results indicate that the equipment tested is capable of demonstrating compliance with the requirements as documented within this report.

#### Notes:

1. This document reports conditions under which testing was conducted and the results of testing performed.
2. Details of test methods used have been recorded and kept on file by the laboratory.
3. Test results apply only to the item(s) tested.

**Approved & Released for MiCOM Labs, Inc. by:**



Graeme Grieve  
Quality Manager MiCOM Labs, Inc.

Gordon Hurst  
President & CEO MiCOM Labs, Inc.

This test report may be reproduced in full only. The document may only be updated by MiCOM Labs personnel. All changes will be noted in the Document History section of the report.



## **4. REFERENCES AND MEASUREMENT UNCERTAINTY**

### **4.1. Normative References**

REF.	PUBLICATION	YEAR	TITLE
I	KDB 662911 D01 & D02	Oct 31 2013	Guidance for measurement of output emission of devices that employ single transmitter with multiple outputs or systems with multiple transmitters operating simultaneously in the same frequency band
II	KDB 558074 D01 v03r05	8th April 2016	Guidance for performing compliance measurements on Digital Transmission Systems (DTS) operating under section 15.247.
III	A2LA	June 2015	R105 - Requirement's When Making Reference to A2LA Accreditation Status
IV	ANSI C63.10	2013	American National Standard for Testing Unlicensed Wireless Devices
V	ANSI C63.4	2014	American National Standards for Methods of Measurement of Radio-Noise Emissions from Low-Voltage Electrical and Electronic Equipment in the Range of 9 kHz to 40 GHz
VI	ETSI TR 100 028	2001-12	Parts 1 and 2 Electromagnetic compatibility and Radio Spectrum Matters (ERM); Uncertainties in the measurement of mobile radio equipment characteristics
VII	FCC 47 CFR Part 15.247	2014	Radio Frequency Devices; Subpart C – Intentional Radiators
VIII	ICES-003	Issue 6 Jan 2016	Spectrum Management and Telecommunications; Interference-Causing Equipment Standard. Information Technology Equipment (Including Digital Apparatus) – Limits and methods of measurement.
IX	M 3003	Edition 3 Nov.2012	Expression of Uncertainty and Confidence in Measurements
X	RSS-247 Issue 1	May 2015	Digital Transmission Systems (DTSs), Frequency Hopping System (FHSs) and Licence-Exempt Local Area Network (LE-LEN) Devices
XI	RSS-Gen Issue 4	November 2014	General Requirements and Information for the Certification of Radiocommunication Equipment
XII	KDB 644545 D03 v01	August 14th 2014	Guidance for IEEE 802.11ac New Rules
XIII	FCC 47 CFR Part 2.1033	2014	FCC requirements and rules regarding photographs and test setup diagrams.

This test report may be reproduced in full only. The document may only be updated by MiCOM Labs personnel. All changes will be noted in the Document History section of the report.



**Title:** Silver Spring Networks Milli™ 5  
**To:** FCC 15.247 & RSS 247  
**Serial #:** SSNT122-U2\_Master Rev A  
**Issue Date:** 13th October 2016  
**Page:** 10 of 22

---

#### **4.2. Test and Uncertainty Procedure**

Conducted and radiated emission measurements were conducted in accordance with American National Standards Institute ANSI C63.4, listed in the Normative References section of this report.

Measurement uncertainty figures are calculated in accordance with ETSI TR 100 028 Parts 1 and 2.

Measurement uncertainties stated are based on a standard uncertainty multiplied by a coverage factor  $k = 2$ , providing a level of confidence of approximately 95 % in accordance with UKAS document M 3003 listed in the Normative References section of this report.

---

This test report may be reproduced in full only. The document may only be updated by MiCOM Labs personnel. All changes will be noted in the Document History section of the report.



**Title:** Silver Spring Networks Milli™ 5  
**To:** FCC 15.247 & RSS 247  
**Serial #:** SSNT122-U2\_Master Rev A  
**Issue Date:** 13th October 2016  
**Page:** 11 of 22

## 5. PRODUCT DETAILS AND TEST CONFIGURATIONS

### 5.1. Technical Details

Details	Description
Purpose:	Test of the Silver Spring Networks Milli™ 5 to FCC CFR 47 Part 15 Subpart C 15.247 (DTS) and Industry Canada RSS-247. Radio Frequency Devices; Subpart C – Intentional Radiators
Applicant:	Silver Spring Networks 230 W Tasman Dr San Jose California 95134 USA
Manufacturer:	As Applicant
Laboratory performing the tests:	MiCOM Labs, Inc. 575 Boulder Court Pleasanton California 94566 USA
Test report reference number:	SSNT122-U2_Master
Date EUT received:	30 <sup>th</sup> August 2016
Standard(s) applied:	FCC CFR 47 Part 15 Subpart C 15.247 (DTS) & IC RSS-247
Dates of test (from - to):	30 <sup>th</sup> August to 6 <sup>th</sup> September 2016
No of Units Tested:	1
Type of Equipment:	Network Interface Card (NIC)
Product Family Name:	Milli™ 5
Model(s):	Milli™ 5
Location for use:	Indoor/Outdoor
Declared Frequency Range(s):	902-928 MHz;
Primary function of equipment:	Plug-in radio device, will communicate over 900 MHz
Secondary function of equipment:	None Provided
Type of Modulation:	FSK
EUT Modes of Operation:	2FSK
Declared Nominal Output Power (Peak):	902-928 MHz:: +24 dBm
Transmit/Receive Operation:	Transceiver - Half Duplex
Rated Input Voltage and Current:	3.3Vdc
Operating Temperature Range:	Declared Range -40°C to +85°C
ITU Emission Designator:	108KF1D
Equipment Dimensions:	25 x 30 mm
Weight:	5 grams
Hardware Rev:	1.0
Software Rev:	Release FW 1.0

This test report may be reproduced in full only. The document may only be updated by MiCOM Labs personnel. All changes will be noted in the Document History section of the report.



**Title:** Silver Spring Networks Milli™ 5  
**To:** FCC 15.247 & RSS 247  
**Serial #:** SSNT122-U2\_Master Rev A  
**Issue Date:** 13th October 2016  
**Page:** 12 of 22

---

## **5.2. Scope Of Test Program**

### **Silver Spring Networks Milli™ 5**

The scope of the test program was to test the Silver Spring Networks Milli™ 5, Network Interface Card (NIC) configurations in the frequency ranges 902-928 MHz; for compliance against the following specification:

#### **FCC CFR 47 Part 15 Subpart C 15.247**

Radio Frequency Devices; Subpart C – Intentional Radiators

#### **IC RSS 247**

Digital Transmission Systems (DTSs), Frequency Hopping Systems (FHSs) and Licence-Exempt Local Area Network (LE-LAN) Devices

### **The following product description was provided by the manufacturer**

Milli 5 is a mesh-enabled sensor networking platform to connect small, battery-powered devices for emerging smart energy, smart city, and other IoT applications. The “Milli 5” can enable applications such as smart gas and water metering, waste management sensors, smart parking monitors, pollution and emissions sensors, industrial equipment monitoring, and smart agriculture sensors, among others, to reliably operate for up to 20 years in the field, without sacrificing the multi-layer security, standards compliance, and IPv6 addressing required by sophisticated IoT operators.

---

This test report may be reproduced in full only. The document may only be updated by MiCOM Labs personnel. All changes will be noted in the Document History section of the report.

**Silver Spring Networks Milli™ 5**

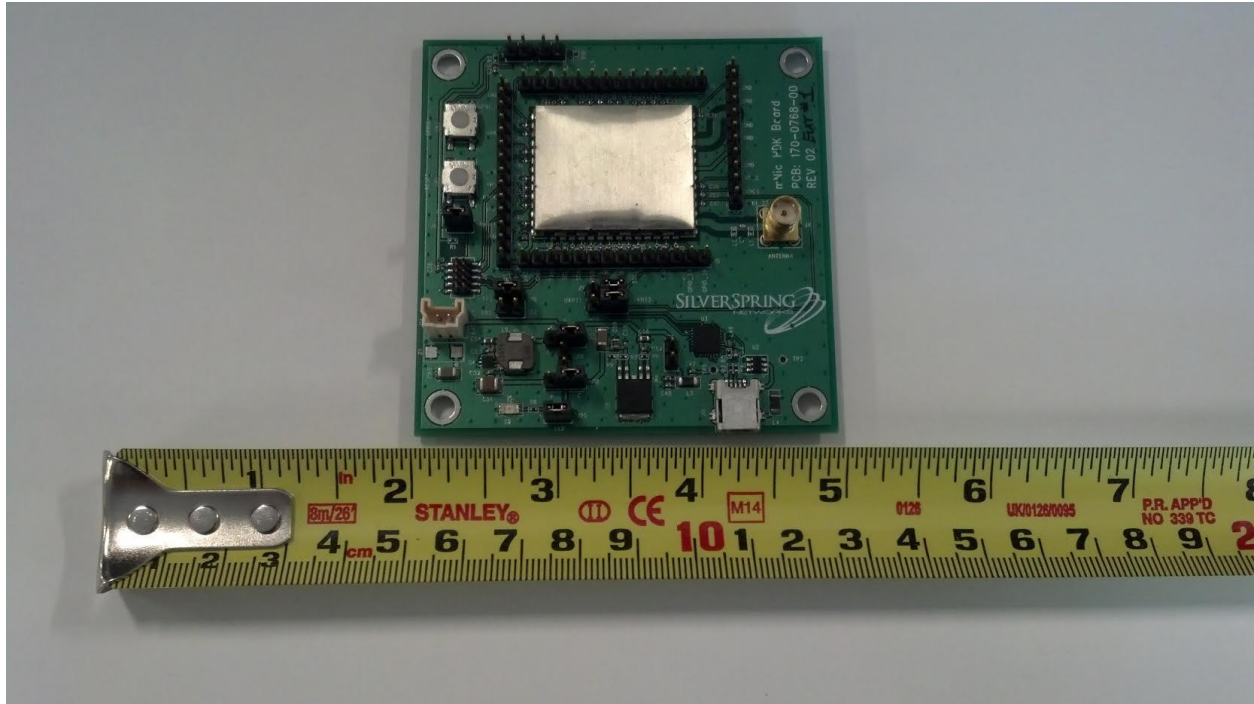

This test report may be reproduced in full only. The document may only be updated by MiCOM Labs personnel. All changes will be noted in the Document History section of the report.



### 5.3. Equipment Model(s) and Serial Number(s)

Type	Description	Manufacturer	Model	Serial no.
EUT	Radio Module - Network Interface Card (NIC)	Silver Spring Networks	Milli™ 5	0013500700000881
Support Equipment	Laptop	Lenovo	--	--

### 5.4. Antenna Details

Type	Manufacturer	Model	Family	Gain (dBi)	BF Gain	Dir BW	X-Pol	Frequency Band (MHz)
External	Silver Spring Networks	178-000035	Omni	3.0	-	360	-	902-928

BF Gain - Beamforming Gain  
Dir BW - Directional BeamWidth  
X-Pol - Cross Polarization

### 5.5. Cabling and I/O Ports

The following is a description of the cable and input, output ports available on the EUT; Number and type of I/O ports;

Port Type	Port Description	Qty	Screened (Yes/ No)
Serial	Console – Maintenance Terminal	1	NO
dc Input	3.3 Vdc Jack	1	NO
RF Antenna	RF Connectors	1	NO



**Title:** Silver Spring Networks Milli™ 5  
**To:** FCC 15.247 & RSS 247  
**Serial #:** SSNT122-U2\_Master Rev A  
**Issue Date:** 13th October 2016  
**Page:** 15 of 22

## **5.6. Test Configurations**

Results for the following configurations are provided in this report:

Operational Mode(s) (FHSS)	Data Rate with Highest Power kbps	Channel Frequency (MHz)		
		Low	Mid	High
<b>902 - 928 MHz</b>				
2FSK	50 kbps	902.2	915.2	927.8

## **5.7. Equipment Modifications**

The following modifications were required to bring the equipment into compliance:

1. NONE

## **5.8. Deviations from the Test Standard**

The following deviations from the test standard were required in order to complete the test program:

1. NONE

---

This test report may be reproduced in full only. The document may only be updated by MiCOM Labs personnel. All changes will be noted in the Document History section of the report.



**Title:** Silver Spring Networks Milli™ 5  
**To:** FCC 15.247 & RSS 247  
**Serial #:** SSNT122-U2\_Master Rev A  
**Issue Date:** 13th October 2016  
**Page:** 16 of 22

## 6. TEST SUMMARY

List of Measurements

Test Header	Result	Comments
<b>Conducted Testing</b>	See Report SSNT122-U2_Conducted Addendum	
15.247(a)(2) 20 dB & 99% Bandwidth	Complies	
15.247(a)(2) Number of Channels	Complies	
15.247(a)(2) Channel Spacing	Complies	
15.247(a)(2) Dwell Time & Channel Occupancy	Complies	
15.247(b), 15.31(e) Conducted Output Power	Complies	
15.247(d) Conducted Emissions	Complies	
(1) Conducted Spurious Emissions	Complies	
(2) Conducted Band-Edge Emissions	Complies	
15.247(e) Power Spectral Density	Complies	
<b>Radiated Testing</b>	See Report SSNT122-U2_Radiated Addendum	
(b)(2) Radiated Spurious & Band-Edge Emissions	Complies	
Integral	Complies	
<b>Digital Emissions</b>	See Report SSNT122-U2_Radiated Addendum	
15.209 Digital Emissions	Complies	

This test report may be reproduced in full only. The document may only be updated by MiCOM Labs personnel. All changes will be noted in the Document History section of the report.



## **7. TEST EQUIPMENT CONFIGURATION(S)**

### **7.1. Conducted**

Conducted RF Emission Test Set-up(s)

The following tests were performed using the conducted test set-up shown in the diagram below.

1. 20 dB & 99% Bandwidth
2. Number of Channels
3. Channel Spacing
4. Dwell Time & Channel Occupancy
5. Peak Output Power
6. Power Spectral Density
7. Conducted Spurious Emissions
8. Conducted Spurious Band-Edge Emissions

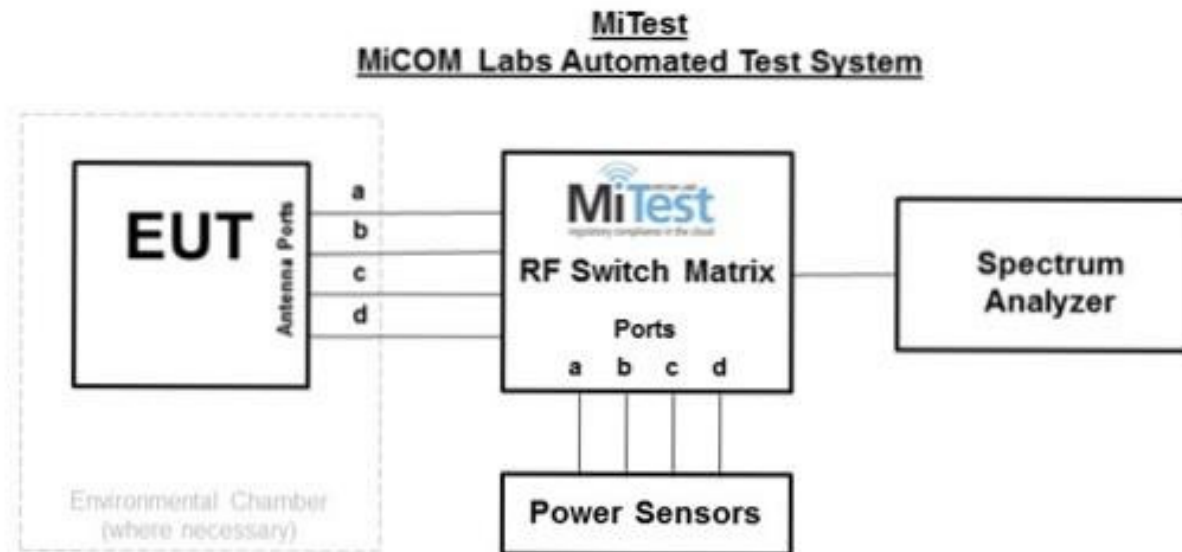

### **Conducted Test Measurement Setup**

A full system calibration was performed on the test station and any resulting system losses (or gains) were taken into account in the production of all final measurement data.



**Title:** Silver Spring Networks Milli™ 5  
**To:** FCC 15.247 & RSS 247  
**Serial #:** SSNT122-U2\_Master Rev A  
**Issue Date:** 13th October 2016  
**Page:** 18 of 22

Asset#	Description	Manufacturer	Model#	Serial#	Calibration Due Date
158	Barometer/Thermometer	Control Company	4196	E2846	01 Dec 2016
249	Resistance Thermometer	Thermotronics	GR2105-02	9340 #2	23 Oct 2016
287	Rohde & Schwarz 40 GHz Receiver	Rhode & Schwarz	ESIB40	100201	02 May 2017
361	Desktop for RF#1, Labview Software installed	Dell	Vostro 220	WS RF#1	Not Required
378	Rohde & Schwarz 40 GHz Receiver with Generator	Rhode & Schwarz	ESIB40	100107/040	04 Aug 2017
380	4x4 RF Switch Box	MiCOM Labs	MiTest RF Switch Box	MIC001	06 Dec 2016
390	USB Power Head 50MHz - 24GHz -60 to +20dBm	Agilent	U2002A	MY50000103	17 Oct 2016
398	Test Software	MiCOM	MiTest ATS	Version 3.0.0.16	Not Required
405	DC Power Supply 0-60V	Agilent	6654A	MY4001826	Cal when used
408	USB to GPIB interface	National Instruments	GPIB-USB HS	14C0DE9	Not Required
435	USB Wideband Power Sensor	Boonton	55006	8730	31 Oct 2016
436	USB Wideband Power Sensor	Boonton	55006	8731	31 Oct 2016
437	USB Wideband Power Sensor	Boonton	55006	8759	31 Oct 2016
445	PoE Injector	D-Link	DPE-101GL	QTAH1E2000625	Not Required
461	Spectrum Analyzer	Agilent	E4440A	MY46185537	13 Aug 2017
75	Environmental Chamber	Thermatron	SE-300-2-2	27946	24 Nov 2016
RF#1 GPIB#1	GPIB cable to Power Supply	HP	GPIB	None	Not Required
RF#1 SMA SA #452	Precision SMA Male RG-402 cable	Fairview Microwave	Precision SMA Male RG 402 coax	None	06 Dec 2016
RF#1 SMA#1	EUT to Mitest box port 1	Flexco	SMA Cable port1	None	06 Dec 2016
RF#1 SMA#2	EUT to Mitest box port 2	Flexco	SMA Cable port2	None	06 Dec 2016
RF#1 SMA#3	EUT to Mitest box port 3	Flexco	SMA Cable port3	None	06 Dec 2016
RF#1 SMA#4	EUT to Mitest box port 4	Flexco	SMA Cable port4	None	06 Dec 2016
RF#1 USB#1	USB Cable to Mitest Box	Dynex	USB Cable	None	Not Required

This test report may be reproduced in full only. The document may only be updated by MiCOM Labs personnel. All changes will be noted in the Document History section of the report.

## 7.2. Radiated Emissions

The following tests were performed using the radiated test set-up shown in the diagram below.

- 1).. Radiated Spurious and Band-Edge Emissions;
- 2) Digital Emissions

### Radiated Emission Measurement Setup Pictorial Representation

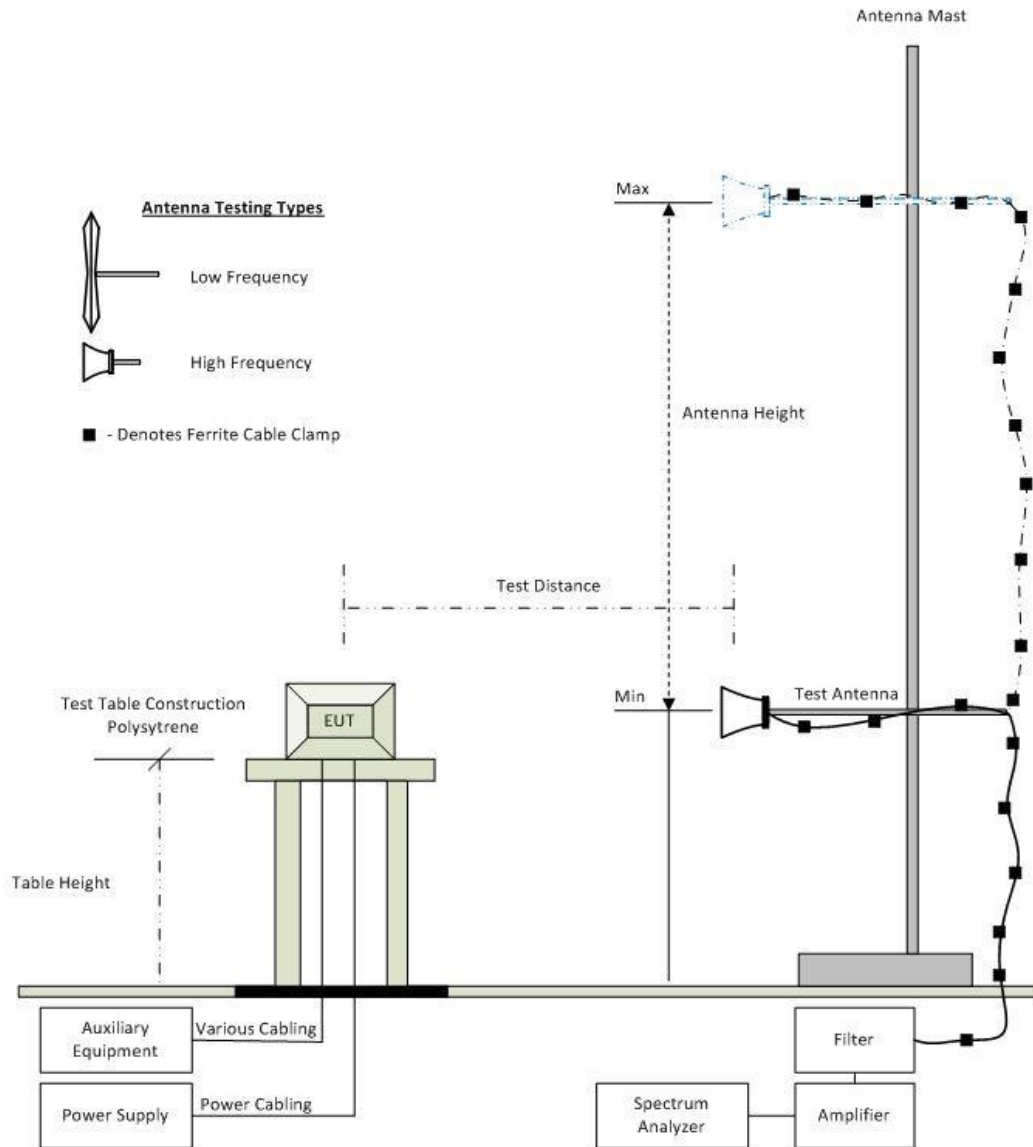

**Radiated Emission Test Setup**

This test report may be reproduced in full only. The document may only be updated by MiCOM Labs personnel. All changes will be noted in the Document History section of the report.



**Title:** Silver Spring Networks Milli™ 5  
**To:** FCC 15.247 & RSS 247  
**Serial #:** SSNT122-U2\_Master Rev A  
**Issue Date:** 13th October 2016  
**Page:** 20 of 22

Asset#	Description	Manufacturer	Model#	Serial#	Calibration Due Date
158	Barometer/Thermometer	Control Company	4196	E2846	01 Dec 2016
170	Video System Controller for Semi Anechoic Chamber	Panasonic	WV-CU101	04R08507	Not Required
287	Rohde & Schwarz 40 GHz Receiver	Rhode & Schwarz	ESIB40	100201	02 May 2017
330	Variac 0-280 Vac	Staco Energy Co	3PN1020B	0546	Cal when used
338	Sunol 30 to 3000 MHz Antenna	Sunol	JB3	A052907	15 Aug 2017
341	900MHz Notch Filter	EWT	EWT-14-0199	H1	16 Aug 2017
346	1.6 TO 10GHz High Pass Filter	EWT	EWT-57-0112	H1	16 Aug 2017
373	26III RMS Multimeter	Fluke	Fluke 26 series III	76080720	26 Oct 2016
396	2.4 GHz Notch Filter	Microtronics	BRM50701	001	16 Aug 2017
397	Amp 10 - 2500MHz	MiCOM Labs	Amp 10 - 2500 MHz	NA	09 Jun 2017
399	ETS 1-18 GHz Horn Antenna	ETS	3117	00154575	10 Jan 2017
406	Amplifier for Radiated Emissions	MiCOM Labs	40dB 1 to 18GHz Amp	0406	09 Jun 2017
410	Desktop Computer	Dell	Inspiron 620	WS38	Not Required
411	Mast/Turntable Controller	Sunol Sciences	SC98V	060199-1D	Not Required
412	USB to GPIB Interface	National Instruments	GPIB-USB HS	11B8DC2	Not Required
413	Mast Controller	Sunol Science	TWR95-4	030801-3	Not Required
414	DC Power Supply 0-60V	HP	6274	1029A01285	Cal when used
415	Turntable Controller	Sunol Sciences	Turntable Controller	None	Not Required
416	Gigabit ethernet filter	ETS-Lingren	Gigafoil 260366	None	Not Required
447	Rad Emissions Test Software	MiCOM	Rad Emissions Test Software Version 1.0.109	447	Not Required
462	Schwarzbeck cable from Antenna to Amplifier.	Schwarzbeck	AK 9513	462	31 May 2017
463	Schwarzbeck cable from Amplifier to Bulkhead.	Schwarzbeck	AK 9513	463	31 May 2017
464	Schwarzbeck cable from Bulkhead to Receiver	Schwarzbeck	AK 9513	464	31 May 2017
480	Cable - Bulkhead to	SRC Haverhill	157-157-	480	02 Jun 2017

This test report may be reproduced in full only. The document may only be updated by MiCOM Labs personnel. All changes will be noted in the Document History section of the report.



**Title:** Silver Spring Networks Milli™ 5  
**To:** FCC 15.247 & RSS 247  
**Serial #:** SSNT122-U2\_Master Rev A  
**Issue Date:** 13th October 2016  
**Page:** 21 of 22

---

	Amp		3050360		
481	Cable - Bulkhead to Receiver	SRC Haverhill	151-151-3050787	481	02 Jun 2017
482	Cable - Amp to Antenna	SRC Haverhill	157-157-3051574	482	02 Jun 2017
502	Test Software for Radiated Emissions	EMISoft	Vasona	Version 5 Build 59	Not Required
87	Uninterruptible Power Supply	Falcon Electric	ED2000-1/2LC	F3471 02/01	Cal when used

---

This test report may be reproduced in full only. The document may only be updated by MiCOM Labs personnel. All changes will be noted in the Document History section of the report.



575 Boulder Court  
Pleasanton, California 94566, USA  
Tel: +1 (925) 462 0304  
Fax: +1 (925) 462 0306  
[www.micomlabs.com](http://www.micomlabs.com)