



*Commercial and Industrial Electric Meter  
Specification*

Version: 1.1

November 10, 1999

# Table of Contents

<b>TABLE OF CONTENTS</b> .....	<b>2</b>
<b>INTRODUCTION</b> .....	<b>3</b>
<b>FIGURE 1. C &amp; I METER COMMUNICATION NETWORK</b> .....	<b>3</b>
<b>FIGURE 2. C &amp; I METER TOP-LEVEL I/O DIAGRAM</b> .....	<b>4</b>
<b>FIGURE 3. C &amp; I METER MOTHERBOARD HIGH-LEVEL DIAGRAM</b> .....	<b>4</b>
<b>POWER SUPPLY MOTHERBOARD</b> .....	<b>5</b>
<b>POWER SUPPLY</b> .....	<b>5</b>
<i>Electrical</i> .....	<i>5</i>
<i>Mechanical</i> .....	<i>5</i>
<i>Environmental</i> .....	<i>5</i>
<b>MICROPROCESSOR INTERFACE MODULE</b> .....	<b>5</b>
<i>Digital specifications</i> .....	<i>5</i>
<i>Electrical</i> .....	<i>6</i>
<i>Mechanical</i> .....	<i>6</i>
<i>Environmental</i> .....	<i>6</i>
<b>NCI MODULE</b> .....	<b>6</b>
<i>Electrical</i> .....	<i>6</i>
<i>Mechanical</i> .....	<i>6</i>
<i>Environmental</i> .....	<i>6</i>
<b>PAGER</b> .....	<b>6</b>
<i>Electrical</i> .....	<i>6</i>
<i>Environmental</i> .....	<i>6</i>
<b>ENCLOSURE</b> .....	<b>7</b>
<b>ANTENNAS</b> .....	<b>7</b>
<u>LAN ANTENNA</u> .....	<i>7</i>
<u>WAN ANTENNA</u> .....	<i>7</i>
<b>HOUSING CONNECTORS</b> .....	<b>7</b>
<b>INTERCONNECT DIAGRAM</b> .....	<b>8</b>

## Introduction

The purpose of this document is to outline the functional requirements for the Commercial and Industrial Electric Meter (C&I Meter) product. The C&I Meter serves the dual purpose of collecting and reporting energy use information from a single commercial/industrial electric meter via a serial connection and of collecting energy use data from several IMUs via the LAN. All energy use data collected may be reported to the Network Operations Center via the LAN to a Gateway or directly via a two-way paging network connection to the WAN.

The C&I Meter shall consist of a microcontroller interface, a Network Communications Interface (NCI), an optional ReFLEX paging network transceiver, an RS-232 serial communication port, and a power supply motherboard. The C&I Meter shall read commercial electric meter data via the RS-232 port. LAN communications between the C&I Meter, the IMU, and the Gateway are provided by a standard Network Communications Interface (NCI). The optional WAN connection is comprised of a ReFLEX Two-Way Data Transceiver paging network module. The microcontroller interface transmits, receives and schedules messages sent between the C&I Meter, the IMUs, the Gateway and the Paging Network. Additionally, the microcontroller interface collects and processes energy use information from the commercial electric meter.

### Figures

Figure 1 depicts the two data communication paths for the C&I Meter.

Figure 2 provides a top-level I/O diagram.

Figure 3 gives a high-level layout of the C&I Meter power supply motherboard components.

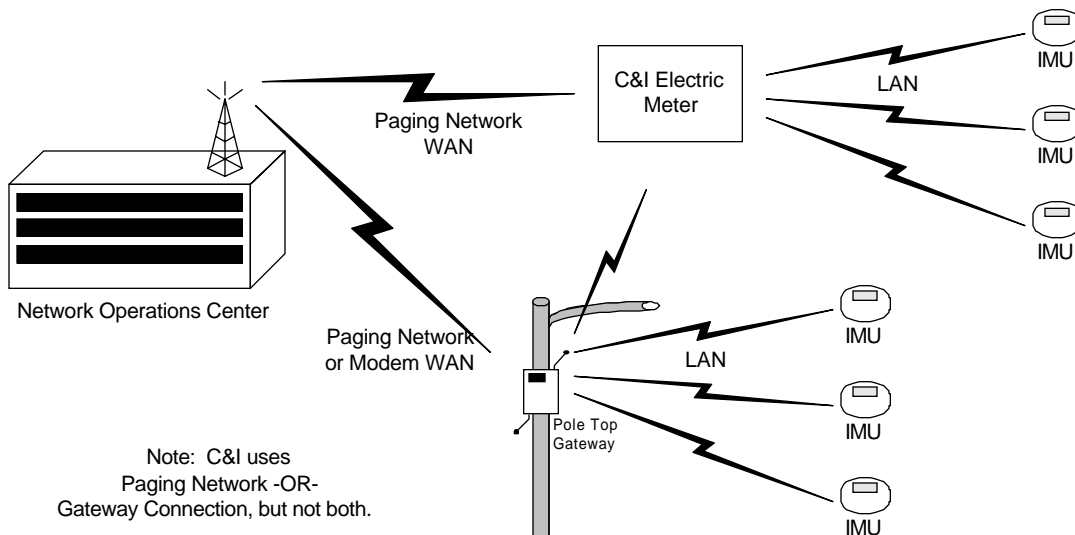

**Figure 1. C & I Meter Communication Network**

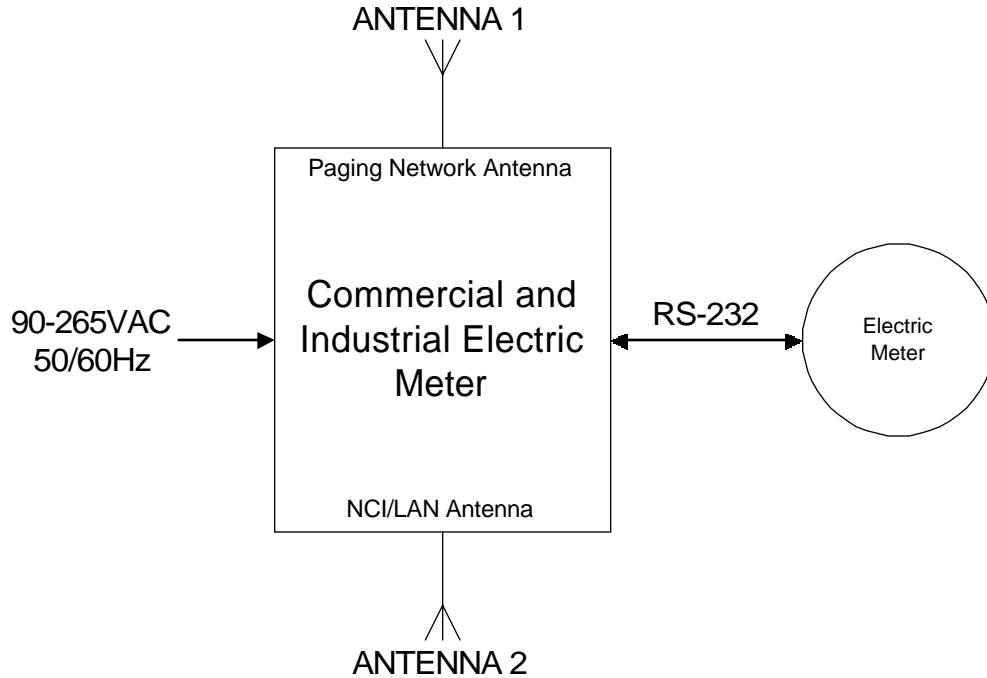

**Figure 2. C & I Meter Top-Level I/O Diagram**

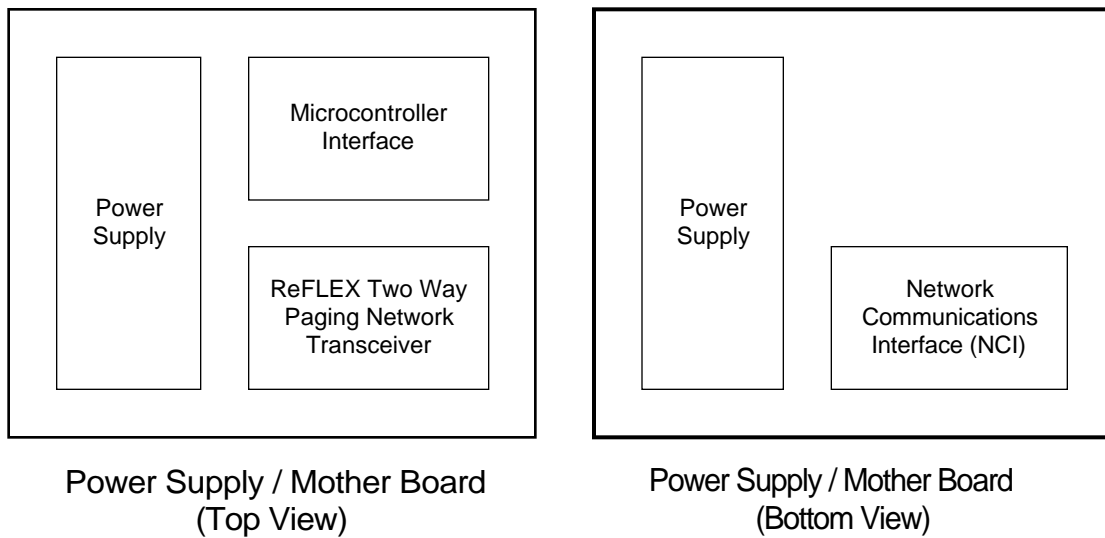

**Figure 3. C & I Meter Motherboard High-Level Diagram**

## ***Power Supply Motherboard***

### **Power Supply**

#### Electrical

- Line input voltage: 90 – 265 AC
- Line input frequency: 50 or 60 Hz.
- Power supply carryover: 100 ms of service interruption.
- Output 1: +5 VDC  $\pm$  5% @ 3.5 A continuous.
- Output 2: +3.6 VDC  $\pm$  5% @ 300 mA output, continuous.
- Maximum ripple:  $\pm$  100 mV.
- Load Regulation:  $\pm$  5 %.
- Isolation designed to applicable portions of the ANSI C-12 standard.
- Appropriate protection against lightning strikes, short circuits and line surges should be placed on the front end of the power supply.

#### Mechanical

- Power Indication LED
- A push button switch for manual microprocessor reset
- 4 mounting holes for the Pager.
- 4 mounting holes for the NCI board.
- 2-22 pin 2 mm centers dual row female shrouded connector for Pager and for NCI board.
- Power connection.
- RS-232 connection to the electric meter.

#### Environmental

- -40 - +85 °C operating temperature range.
- Up to 95 % humidity (non-condensing).

#### Other

- 20 year product life

## **Microprocessor Interface Module**

#### Digital Specifications

- Microprocessor: Epson E0C88 Core, EOC88317F
- Code memory: 128K bytes EPROM
- Data memory: 32K bytes SRAM
- Serial Interfaces: SPI to NCI, RS-232 to E-Meter, TTL level asynchronous serial to pager

#### Electrical

- +3.6 VDC 5%
- 150 mA maximum

#### Mechanical

- All components soldered onto power supply motherboard
- Optionally socketed OTP EPROM
- One serial RS232 port connection to meter
- One serial connection to Paging Network module
- One SPI serial connection to NCI

#### Environmental

- -40 - +85 °C operating temperature range.

### **NCI Module**

#### Electrical

- 1000 mA @ +5 VDC and 150 mA @ +3.6 VDC power supply.
- RF Specification (Refer to NCI specification document).
- Appropriate protection against lightning strikes and Electro Static Discharge (ESD) should be placed between the NCI and the corresponding antenna.

#### Mechanical

- 1-22 pin 2 mm centers dual row male shrouded connector, placed on the bottom of the board for power, serial and other I/O connections.

#### Environmental

- -40 - +85 °C working temperature range.

### **Pager (Optional)**

#### Electrical

- Motorola ReFlex CreateaLink 2XT transceiver.
- 2 A max at +5 VDC power consumption.
- Appropriate protection against lightning strikes and Electro Static Discharge (ESD) should be placed between the Pager and the corresponding antenna.

#### Environmental

- -40 - +85 °C working temperature range.

## ***Enclosure***

- NEMA 4X steel type.
- Powder coated (white preferred for final product).
- 8"x 6"x 3.5" in dimension.
- Dedicated grounding stud
- Removable lid with a weather proof gasket.
- 4 outside connector holes; 1 for the power connector, 1 for the LAN antenna connector and 1 for the WAN antenna connector, 1 for the RS-232 cable to the Electric Meter

## ***Antennas***

### LAN Antenna

- 902 – 928 MHz.
- 6 dBi Gain.
- N type connector.
- 50 Ohms.
- Water resistant.

### WAN Antenna

- 896 – 942 MHz.
- 6 dBi Gain.
- N type connector.
- 50 Ohms.
- Water resistant.

## ***Housing Connectors***

- N type, antenna mount connector with a 1 ft. RG316/U cable and a straight SMA on the other end of the cable.
- ¼" Quick Connect Spade power connection
- RS-232 Screw Terminal Connection for the Electric Meter

## Interconnect Diagram

The following diagram depicts the connections between the modules within the C&I meter interface product

