

MEASUREMENT REPORT

FCC PART 22 & 24 GSM

FCC ID: OWLV72
Applicant: Vanstone Electronic (Beijing) Co., Ltd.
Application Type: Certification
Product: Wireless POS Terminal
Model No.: V72
Brand Name: Aisino
FCC Classification: PCS Licensed Transmitter (PCB)
FCC Rule Part(s): Part 2, Part 22 Subpart H, Part 24 Subpart E
Test Procedure(s): ANSI C63.26-2015, ANSI/TIA-603-E-2016
Test Date: October 12 ~ December 13, 2019

Reviewed By Sunny Sun
(Sunny Sun)
Approved By Robin Wu
(Robin Wu)



The test results relate only to the samples tested.

This equipment has been shown to be capable of compliance with the applicable technical standards as indicated in the measurement report and was tested in accordance with the measurement procedures specified in ANSI C63.26-2015. Test results reported herein relate only to the item(s) tested.

The test report shall not be reproduced except in full without the written approval of MRT Technology (Suzhou) Co., Ltd.

Revision History

Report No.	Version	Description	Issue Date	Note
1909RSU034-U1	Rev. 01	Initial report	12-09-2019	Valid

CONTENTS

Description	Page
General Information	5
1. INTRODUCTION	6
1.1. Scope	6
1.2. MRT Test Location	6
2. PRODUCT INFORMATION	7
2.1. Equipment Description	7
2.2. Product Specification Subjective to this Report.....	7
2.3. EMI Suppression Device(s)/Modifications	7
3. DESCRIPTION OF TEST	8
3.1. Evaluation Procedure	8
3.2. Radiated Measurement	8
4. TEST EQUIPMENT CALIBRATION DATE	10
5. MEASUREMENT UNCERTAINTY	12
6. TEST RESULT	13
6.1. Summary	13
6.2. Occupied Bandwidth	14
6.2.1. Test Limit	14
6.2.2. Test Procedure used	14
6.2.3. Test Setting.....	14
6.2.4. Test Setup	14
6.2.5. Test Result.....	15
6.3. Band Edge Emission and Spurious Emissions at Antenna Terminal	17
6.3.1. Test Limit	17
6.3.2. Test Procedure Used.....	17
6.3.3. Test Setting.....	17
6.3.4. Test Setup	18
6.3.5. Test Result.....	19
6.4. ERP & EIRP	22
6.4.1. Test Limit	22
6.4.2. Test Procedure Used.....	22
6.4.3. Test Setting.....	22
6.4.4. Test Setup	22
6.4.5. Test Result.....	23

6.5.	Radiated Spurious Emissions	25
6.5.1.	Test Limit	25
6.5.2.	Test Procedure Used.....	25
6.5.3.	Test Setting.....	25
6.5.4.	Test Setup	26
6.5.5.	Test Result.....	27
6.6.	Peak-Average Ratio	29
6.6.1.	Test Limit	29
6.6.2.	Test Procedure	29
6.6.3.	Test Setting.....	29
6.6.4.	Test Setup	29
6.6.5.	Test Result.....	30
6.7.	Frequency Stability.....	32
6.7.1.	Test Limit	32
6.7.2.	Test Procedure	32
6.7.3.	Test Setting.....	32
6.7.4.	Test Setup	33
6.7.5.	Test Result.....	34
7.	CONCLUSION.....	35
	Appendix A - Test Setup Photograph.....	36
	Appendix B - EUT Photograph	37

General Information

Applicant:	Vanstone Electronic (Beijing) Co., Ltd.
Applicant Address:	Room 4-18, No.25, Landianchang South Road, Haidian, Beijing, China 100097
Manufacturer:	Vanstone Electronic (Beijing) Co., Ltd.
Manufacturer Address:	Room 4-18, No.25, Landianchang South Road, Haidian, Beijing, China 100097
Test Site:	MRT Technology (Suzhou) Co., Ltd
Test Site Address:	D8 Building, No.2 Tian'edang Rd., Wuzhong Economic Development Zone, Suzhou, China
Test Device Serial No.:	N/A <input type="checkbox"/> Production <input checked="" type="checkbox"/> Pre-Production <input type="checkbox"/> Engineering

Test Facility / Accreditations

Measurements were performed at MRT Laboratory located in Tian'edang Rd., Suzhou, China.

- MRT facility is a FCC registered (MRT Reg. No. 893164) test facility with the site description report on file and has met all the requirements specified in ANSI C63.4-2014.
- MRT facility is an IC registered (MRT Reg. No. 11384A-1) test laboratory with the site description on file at Industry Canada.
- MRT facility is a VCCI registered (R-20025, G-20034, C-20020, T-20020) test laboratory with the site description on file at VCCI Council.
- MRT Lab is accredited to ISO 17025 by the American Association for Laboratory Accreditation (A2LA) under the American Association for Laboratory Accreditation Program (A2LA Cert. No. 3628.01) in EMC, Telecommunications, Radio and SAR testing.



1. INTRODUCTION

1.1. Scope

Measurement and determination of electromagnetic emissions (EMC) of radio frequency devices including intentional and/or unintentional radiators for compliance with the technical rules and regulations of the Federal Communications Commission and the Innovation, Science and Economic Development Canada and Certification and Engineering Bureau.

1.2. MRT Test Location

The map below shows the location of the MRT LABORATORY, its proximity to the Taihu Lake. These measurement tests were conducted at the MRT Technology (Suzhou) Co., Ltd. Facility located at D8 Building, No.2 Tian'edang Rd., Wuzhong Economic Development Zone, Suzhou, China. The measurement facility compliant with the test site requirements specified in ANSI C63.4-2014.



2. PRODUCT INFORMATION

2.1. Equipment Description

Product Name:	Wireless POS Terminal
Model No.:	V72
Brand Name:	Aisino
GSM Specification:	GPRS850/900/1800/1900
Wi-Fi Specification:	802.11b/g/n-HT20
NFC:	13.56MHz
Accessory	
Adapter:	Model No.: A8A-050200U-US1 Input: 100-240V ~ 50/60Hz 0.35A Output: 5V = 2.0A

2.2. Product Specification Subjective to this Report

T _x Frequency Range:	GPRS850: 824.2 ~ 848.8MHz, GPRS1900: 1850.2 ~ 1909.8MHz
R _x Frequency Range:	GPRS850: 869.2 ~ 893.8MHz, GPRS1900: 1930.2 ~ 1989.8MHz
Type of Modulation:	GMSK
Antenna Type:	FPC Antenna
Antenna Gain:	GPRS850: 0.5dBi GPRS1900: 0.8dBi

Note: For other features of this EUT, test report will be issued separately.

2.3. EMI Suppression Device(s)/Modifications

No EMI suppression device(s) were added and no modifications were made during testing.

3. DESCRIPTION OF TEST

3.1. Evaluation Procedure

The measurement procedures described in the American National Standard for Compliance Testing of Transmitters Used in Licensed Radio Services (ANSI C63.26-2015) was used in the measurement.

Deviation from measurement procedure.....None

3.2. Radiated Measurement

The radiated test facilities consisted of an indoor 3 meter semi-anechoic chamber used for final measurements and exploratory measurements, when necessary. The measurement area is contained within the semi-anechoic chamber which is shielded from any ambient interference. For measurements above 1GHz absorbers are arranged on the floor between the turn table and the antenna mast in such a way so as to maximize the reduction of reflections. For measurements below 1GHz, the absorbers are removed. A turntable is used for radiated measurement. It is a continuously rotatable, remote controlled, metallic turntable and 2 meters (6.56 ft.) in diameter. The turn table is flush with the raised floor of the chamber in order to maintain its function as a ground plane. An 80cm high PVC support structure is placed on top of the turntable.

For all measurements, the spectrum was scanned through all EUT azimuths and from 1 to 4 meter receive antenna height using a broadband antenna from 30MHz up to the upper frequency shown in 15.33(b)(1) depending on the highest frequency generated or used in the device or on which the device operates or tunes. For frequencies above 1GHz, linearly polarized double ridge horn antennas were used. For frequencies below 30MHz, a calibrated loop antenna was used. When exploratory measurements were necessary, they were performed at 1 meter test distance inside the semi-anechoic chamber using broadband antennas, broadband amplifiers, and spectrum analyzers to determine the frequencies and modes producing the maximum emissions. Sufficient time for the EUT, support equipment, and test equipment was allowed in order for them to warm up to their normal operating condition. The test set-up for frequencies below 1GHz was placed on top of the 0.8 meter high, 1 x 1.5 meter table; and test set-up for frequencies 1-40GHz was placed on top of the 1.5 meter high, 1 x 1.5 meter table. The EUT, support equipment, and interconnecting cables were arranged and manipulated to maximize each emission. Appropriate precaution was taken to ensure that all emissions from the EUT were maximized and investigated. The system configuration, clock speed, mode of operation or video resolution, if applicable, turntable azimuth, and receive antenna height was noted for each frequency found.

Final measurements were made in the semi-anechoic chamber using calibrated, linearly polarized broadband and horn antennas. The test setup was configured to the setup that produced the worst case emissions. The spectrum analyzer was set to investigate all frequencies required for testing to compare the highest radiated disturbances with respect to the specified limits. The turntable

containing the EUT was rotated through 360 degrees and the height of the receive antenna was varied 1 to 4 meters and stopped at the azimuth and height producing the maximum emission. Each emission was maximized by changing the orientation of the EUT through three orthogonal planes and changing the polarity of the receive antenna, which produced the worst-case emissions.

According to 3dB Beam-Width of horn antenna, the horn antenna should be always directed to the EUT when rising height.

4. TEST EQUIPMENT CALIBRATION DATE

Conducted Emissions - SR2

Instrument	Manufacturer	Type No.	Asset No.	Cali. Interval	Cali. Due Date
EMI Test Receiver	R&S	ESR3	MRTSUE06185	1 year	2020/04/15
Two-Line V-Network	R&S	ENV 216	MRTSUE06002	1 year	2020/06/13
Two-Line V-Network	R&S	ENV 216	MRTSUE06003	1 year	2020/06/13
Thermohygrometer	Testo	608-H1	MRTSUE06404	1 year	2020/08/08
Shielding Room	MIX-BEP	Chamber-SR2	MRTSUE06215	N/A	N/A

Radiated Emissions - AC1

Instrument	Manufacturer	Type No.	Asset No.	Cali. Interval	Cali. Due Date
EMI Test Receiver	R&S	ESR7	MRTSUE06001	1 year	2020/08/01
PXA Signal Analyzer	Keysight	9030B	MRTSUE06395	1 year	2020/09/03
Loop Antenna	Schwarzbeck	FMZB 1519	MRTSUE06025	1 year	2020/11/10
Bilog Period Antenna	Schwarzbeck	VULB 9168	MRTSUE06172	1 year	2020/03/31
Broad Band Horn Antenna	Schwarzbeck	BBHA 9120D	MRTSUE06023	1 year	2020/10/13
Broad Band Horn Antenna	Schwarzbeck	BBHA 9170	MRTSUE06024	1 year	2019/12/17
Microwave System Amplifier	Agilent	83017A	MRTSUE06076	1 year	2020/11/15
Preamplifier	Schwarzbeck	BBV 9721	MRTSUE06121	1 year	2020/06/11
Thermohygrometer	Testo	608-H1	MRTSUE06403	1 year	2020/08/08
Anechoic Chamber	TDK	Chamber-AC1	MRTSUE06212	1 year	2020/04/30

Radiated Emission - AC2

Instrument	Manufacturer	Type No.	Asset No.	Cali. Interval	Cali. Due Date
Spectrum Analyzer	Keysight	N9038A	MRTSUE06125	1 year	2020/08/01
Loop Antenna	Schwarzbeck	FMZB 1519	MRTSUE06025	1 year	2020/11/10
Bilog Period Antenna	Schwarzbeck	VULB 9162	MRTSUE06022	1 year	2020/10/13
Horn Antenna	Schwarzbeck	BBHA9120D	MRTSUE06171	1 year	2020/10/27
Broad Band Horn Antenna	Schwarzbeck	BBHA 9170	MRTSUE06024	1 year	2019/12/17
Broadband Coaxial Preamplifier	Schwarzbeck	BBV 9718	MRTSUE06176	1 year	2020/11/15
Preamplifier	Schwarzbeck	BBV 9721	MRTSUE06121	1 year	2020/06/11
Temperature/Humidity Meter	Minggao	ETH529	MRTSUE06170	1 year	2019/12/13
Anechoic Chamber	RIKEN	Chamber-AC2	MRTSUE06213	1 year	2020/04/30

Conducted Test Equipment - TR3

Instrument	Manufacturer	Type No.	Asset No.	Cali. Interval	Cali. Due Date
EXA Signal Analyzer	Agilent	N9020A	MRTSUE06106	1 year	2020/04/15
EXA Signal Analyzer	Keysight	N9010B	MRTSUE06452	1 year	2020/07/11
Signal Analyzer	R&S	FSV40	MRTSUE06218	1 year	2020/04/15
Power Meter	Agilent	U2021XA	MRTSUE06030	1 year	2020/11/18
USB wideband power sensor	Keysight	U2021XA	MRTSUE06446	1 year	2020/06/30
USB wideband power sensor	Keysight	U2021XA	MRTSUE06447	1 year	2020/06/30
Bluetooth Test Set	Anritsu	MT8852B-042	MRTSUE06389	1 year	2020/06/13
Audio Analyzer	Agilent	U8903B	MRTSUE06143	1 year	2020/06/13
Modulation Analyzer	HP	8901A	MRTSUE06098	1 year	2020/10/10
Wideband Radio Communication Tester	R&S	CMW 500	MRTSUE06243	1 year	2020/11/07
DC Power Supply	GWINSTEK	DPS-3303C	MRTSUE06064	N/A	N/A
Temperature & Humidity Chamber	BAOYT	BYH-150CL	MRTSUE06051	1 year	2020/11/07
Thermohygrometer	testo	608-H1	MRTSUE06401	1 year	2020/08/08

Software	Version	Function
EMI Software	V3	EMI Test Software

5. MEASUREMENT UNCERTAINTY

Where relevant, the following test uncertainty levels have been estimated for tests performed on the EUT as specified in CISPR 16-4-2. This uncertainty represents an expanded uncertainty expressed at approximately the 95% confidence level using a coverage factor of $k = 2$.

Conducted Emission Measurement - SR2

The maximum measurement uncertainty is evaluated as:
 9kHz~150kHz: 3.84dB
 150kHz~30MHz: 3.46dB

Radiated Emission Measurement - AC1

The maximum measurement uncertainty is evaluated as:
 Horizontal: 30MHz~300MHz: 4.07dB
 300MHz~1GHz: 3.63dB
 1GHz~18GHz: 4.16dB
 Vertical: 30MHz~300MHz: 4.18dB
 300MHz~1GHz: 3.60dB
 1GHz~18GHz: 4.76dB

Radiated Emission Measurement - AC2

The maximum measurement uncertainty is evaluated as:
 Horizontal: 30MHz~300MHz: 3.75dB
 300MHz~1GHz: 3.53dB
 1GHz~18GHz: 4.28dB
 Vertical: 30MHz~300MHz: 3.86dB
 300MHz~1GHz: 3.53dB
 1GHz~18GHz: 4.33dB

6. TEST RESULT

6.1. Summary

FCC Part Section(s)	Test Description	Test Limit	Test Condition	Test Result	Reference
2.1049	Occupied bandwidth	N/A	Conducted	Pass	Section 6.2
2.1051 22.917(a) 24.238(a)	Band Edge / Conducted Spurious Emissions	$< -43 + 10\log[P(\text{Watts})]$ at Band Edge and for all out-of-band emissions		Pass	Section 6.3
22.913(d) 24.232(d)	Peak-Average Ratio	$< 13 \text{ dB}$		Pass	Section 6.5
2.1046	Transmitter Conducted Output Power	N/A		Pass	Section 6.4
22.913(a)(5)	Effective Radiated Power	$< 7 \text{ Watts max. ERP}$		Pass	
24.232(c)	Equivalent Isotropic Radiated Power	$< 2 \text{ Watts max. EIRP}$		Pass	
2.1053 22.917(a) 24.238(a)	Undesirable Emissions	$< -43 + \log_{10}(P[\text{Watts}])$ for all out-of-band emissions	Radiated	Pass	Section 6.5
2.1055 22.355 24.235	Frequency Stability	$\pm 2.5\text{ppm}$	Conducted	Pass	Section 6.6

Notes:

- 1) The analyzer plots shown in this section were all taken with a correction table loaded into the analyzer. The correction table was used to account for the losses of the cables and attenuators used as part of the system to connect the EUT to the analyzer at all frequencies of interest.
- 2) All supported modulation types were evaluated. The worst case emission of modulation was selected. Therefore, the EIRP power, Frequency Stability, Channel Edge, Conducted Emission and Radiated Emission were presented in the test report.

6.2. Occupied Bandwidth

6.2.1. Test Limit

N/A

6.2.2. Test Procedure used

ANSI C63.26-2015 - Section 5.4.3 & 5.4.4

6.2.3. Test Setting

1. The signal analyzer's automatic bandwidth measurement capability was used to perform the 99% occupied bandwidth and the 26dB bandwidth. The bandwidth measurement was not influenced by any intermediate power nulls in the fundamental emission.
2. RBW = 1% - 5% of the anticipated OBW
3. VBW $\geq 3 \times$ RBW
4. Detector = Peak
5. Trace mode = max hold
6. Sweep = auto couple
7. The trace was allowed to stabilize

6.2.4. Test Setup

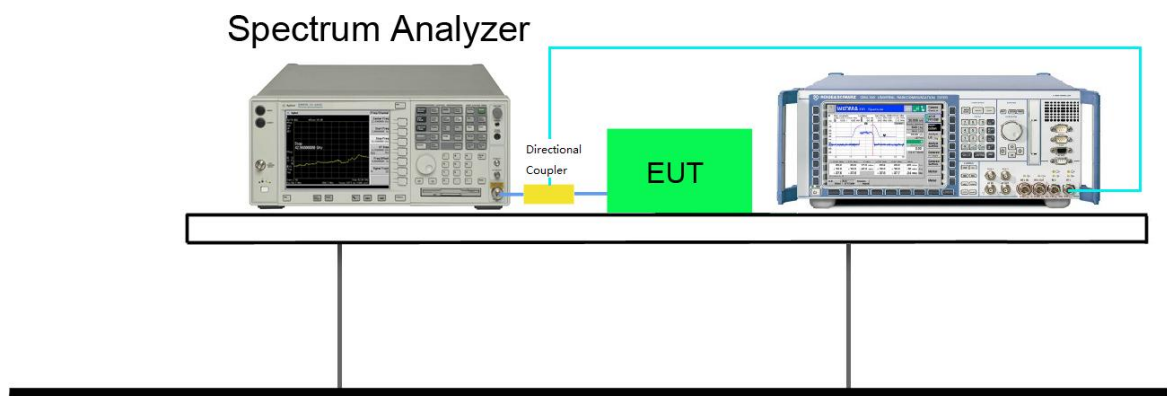

6.2.5. Test Result

Product	Wireless POS Terminal	Temperature	25°C
Test Engineer	Ternence Wang	Relative Humidity	52%
Test Site	TR3	Test Date	2019/11/16

Test Mode	Channel No.	Frequency (MHz)	99% Occupied Bandwidth (kHz)	26dB Occupied Bandwidth (kHz)
GPRS850	128	824.2	238.1	315.3
	189	836.4	238.9	305.5
	251	848.8	238.9	311.1
GPRS1900	512	1850.2	235.6	306.8
	661	1880.0	236.7	307.9
	810	1909.8	236.1	306.0

GPRS850 Occupied Bandwidth

Channel 128 (824.2MHz)

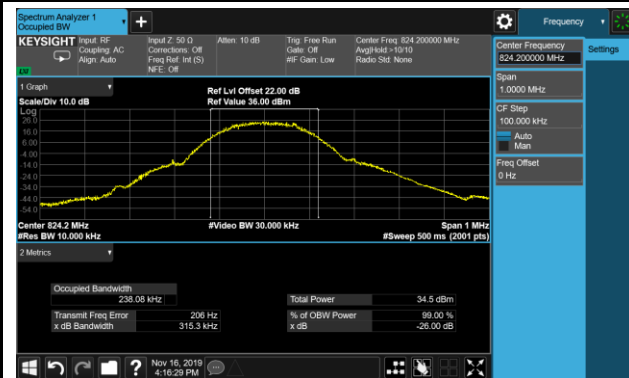

Channel 189 (836.4MHz)



Channel 251 (848.8MHz)



GPRS1900 Occupied Bandwidth

Channel 512 (1850.2MHz)



Channel 661 (1880.0MHz)



Channel 810 (1909.8MHz)



6.3. Band Edge Emission and Spurious Emissions at Antenna Terminal

6.3.1. Test Limit

For FCC Part 22.917(a):

The power of any emission outside of the authorized operating frequency ranges must be attenuated below the transmitting power (P) by a factor of at least $43 + 10\log(P)$ dB.

For FCC Part 24.238(a):

The power of any emission outside of the authorized operating frequency ranges must be attenuated below the transmitting power (P) by a factor of at least $43 + 10\log(P)$ dB.

6.3.2. Test Procedure Used

ANSI C63.26 - Section 5.7

6.3.3. Test Setting

For Band Edge Emission at Antenna Terminal

1. Span was set large enough so as to capture all out of band emissions near the band edge
2. RBW \geq 1% of the emission bandwidth
3. VBW \geq 3 x RBW
4. Detector = RMS
5. Number of sweep points \geq 2 x Span/RBW
6. Trace mode = trace average for continuous emissions, max hold for pulse emissions
7. Sweep = auto couple
8. The trace was allowed to stabilize

For Spurious Emissions at Antenna Terminal

1. Start frequency was set to 30MHz and stop frequency was set to 10GHz
2. RBW = 1MHz
3. VBW \geq 3*RBW
4. Sweep time = auto
5. Detector = power averaging (rms)
6. Set sweep trigger to "free run."
7. Sweep time = auto couple

8. Trace average at least 100 traces in power averaging (rms) mode if sweep is set to auto-couple. To accurately determine the average power over the on and off time of the transmitter, it can be necessary to increase the number of traces to be averaged above 100, or if using a manually configured sweep time, increase the sweep time.

6.3.4. Test Setup

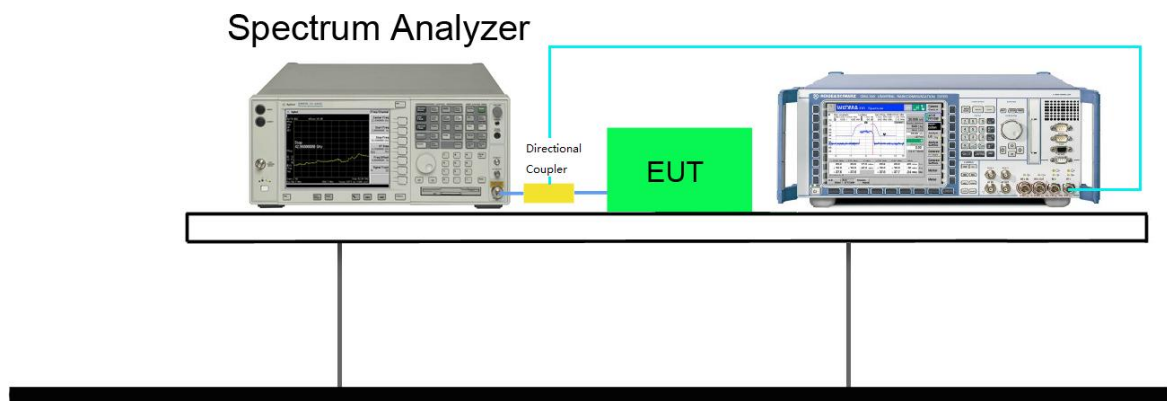

6.3.5. Test Result

Product	Wireless POS Terminal	Temperature	25°C
Test Engineer	Ternence Wang	Relative Humidity	52%
Test Site	TR3	Test Date	2019/11/16 ~ 2019/12/13

Mode	Channel No.	Frequency (MHz)	Modulation	Test Result
GPRS850	128	824.20	GMSK	Pass
GPRS850	189	836.40	GMSK	Pass
GPRS850	251	848.80	GMSK	Pass
GPRS1900	512	1850.20	GMSK	Pass
GPRS1900	661	1880.00	GMSK	Pass
GPRS1900	810	1909.80	GMSK	Pass

GPRS850 Band Edge

Channel 128 (824.20MHz)



Channel 251 (848.80MHz)



GPRS850 Conducted Spurious Emission

Channel 128 (824.20MHz)



Channel 189 (836.40MHz)



Channel 251 (848.80MHz)

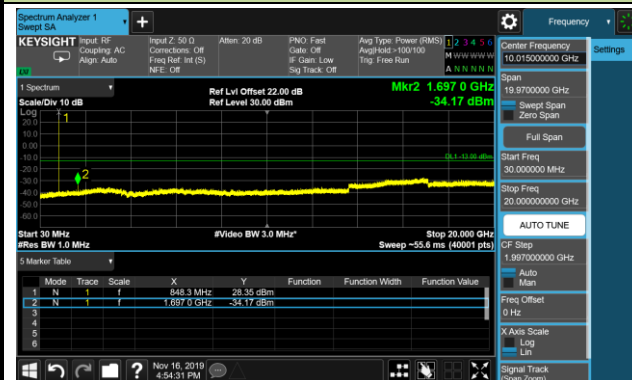

GPRS1900 Band Edge

Channel 512 (1850.20MHz)



Channel 810 (1909.80MHz)



GPRS1900 Conducted Spurious Emission

Channel 512 (1850.20MHz)

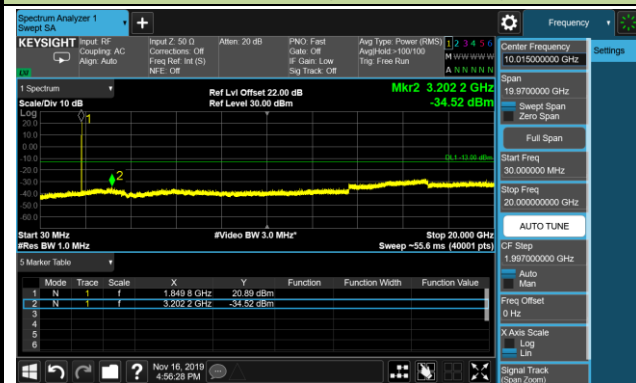

Channel 661 (1880.00MHz)



Channel 810 (1909.80MHz)



6.4. ERP & EIRP

6.4.1. Test Limit

For FCC Part 22.913(a)(5):

The ERP of mobile transmitters and auxiliary test transmitters must not exceed 7 Watts.

For FCC Part 24.232(c):

The EIRP of mobile transmitters and auxiliary test transmitters must not exceed 2 Watts.

6.4.2. Test Procedure Used

ANSI C63.26-2015 - Section 5.2.4.2 & 5.2.7

6.4.3. Test Setting

Average power measurements were performed only when the EUT was transmitting at its maximum power control level using a broadband power meter with a pulse sensor. The power meter implemented triggering and gating capabilities which were set up such that power measurements were recorded only during the ON time of the transmitter.

6.4.4. Test Setup

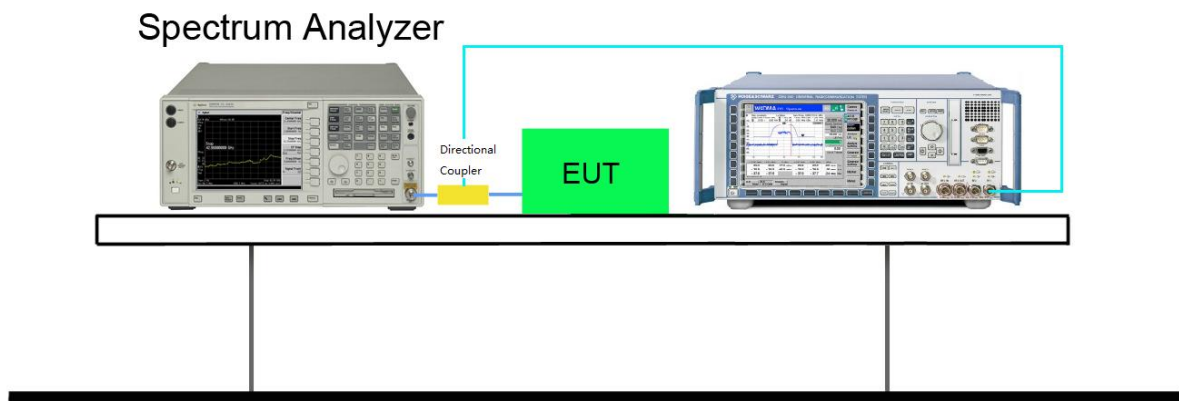

6.4.5. Test Result

Product	Wireless POS Terminal	Temperature	25°C
Test Engineer	Ternence Wang	Relative Humidity	54%
Test Site	TR3	Test Date	2019/11/16
Test Item	ERP - GPRS850		

Test Mode	Frequency (MHz)	Avg. Burst Power (dBm)	ERP (dBm)	ERP (W)	Limit (W)	Result
GPRS850 (1 Slot)	824.2	32.07	30.42	1.1015	7	Pass
	836.4	32.43	30.78	1.1967	7	Pass
	848.8	32.65	31.00	1.2589	7	Pass
GPRS850 (2 Slot)	824.2	30.14	28.49	0.7063	7	Pass
	836.4	30.55	28.90	0.7762	7	Pass
	848.8	30.98	29.33	0.8570	7	Pass
GPRS850 (3 Slot)	824.2	28.05	26.40	0.4365	7	Pass
	836.4	28.51	26.86	0.4853	7	Pass
	848.8	28.91	27.26	0.5321	7	Pass
GPRS850 (4 Slot)	824.2	26.01	24.36	0.2729	7	Pass
	836.4	26.45	24.80	0.3020	7	Pass
	848.8	26.81	25.16	0.3281	7	Pass

Note 1: Frame Power (dBm) = Avg. Burst Power (dBm) + Duty Cycle Factor (dB)

Note 2: ERP (dBm) = Avg. Burst Power (dBm) + Antenna Gain (dBi) - Cable Loss (dB) Antenna Gain = 0.5dBi, Cable Loss = 2.15dB

Product	Wireless POS Terminal	Temperature	25°C
Test Engineer	Ternence Wang	Relative Humidity	54%
Test Site	TR3	Test Date	2019/11/16
Test Item	EIRP - GPRS1900		

Test Mode	Frequency (MHz)	Avg. Burst Power (dBm)	EIRP (dBm)	EIRP (W)	Limit (W)	Result
GPRS1900 (1 Slot)	1850.2	28.75	26.55	0.4519	2	Pass
	1880.0	28.57	26.37	0.4335	2	Pass
	1909.8	28.21	26.01	0.3990	2	Pass
GPRS1900 (2 Slot)	1850.2	27.13	24.93	0.3112	2	Pass
	1880.0	27.06	24.86	0.3062	2	Pass
	1909.8	26.75	24.55	0.2851	2	Pass
GPRS1900 (3 Slot)	1850.2	25.23	23.03	0.2009	2	Pass
	1880.0	25.22	23.02	0.2004	2	Pass
	1909.8	24.91	22.71	0.1866	2	Pass
GPRS1900 (4 Slot)	1850.2	23.33	21.13	0.1297	2	Pass
	1880.0	23.30	21.10	0.1288	2	Pass
	1909.8	22.96	20.76	0.1191	2	Pass

Note 1: Frame Power (dBm) = Avg. Burst Power (dBm) + Duty Cycle Factor (dB)

Note 2: EIRP (dBm) = Avg. Burst Power (dBm) + Antenna Gain (dBi) - Cable Loss (dB)

Antenna Gain = 0.8dBi, Cable Loss = 3dB

6.5. Radiated Spurious Emissions

6.5.1. Test Limit

For FCC Part 22.917(a):

The power of any emission outside of the authorized operating frequency ranges must be attenuated below the transmitting power (P) by a factor of at least $43 + 10\log(P)$ dB.

For FCC Part 24.238(a):

The power of any emission outside of the authorized operating frequency ranges must be attenuated below the transmitting power (P) by a factor of at least $43 + 10\log(P)$ dB.

6.5.2. Test Procedure Used

ANSI C63.26-2015 - Section 5.2.7 & 5.5

6.5.3. Test Setting

1. RBW = 100kHz or 1MHz
2. VBW $\geq 3 \times$ RBW
3. Sweep time $\geq 10 \times$ (number of points in sweep) \times (transmission symbol period)
4. Detector = Peak
5. Trace mode = max hold
6. The trace was allowed to stabilize

6.5.4. Test Setup

Below 1GHz Test Setup:

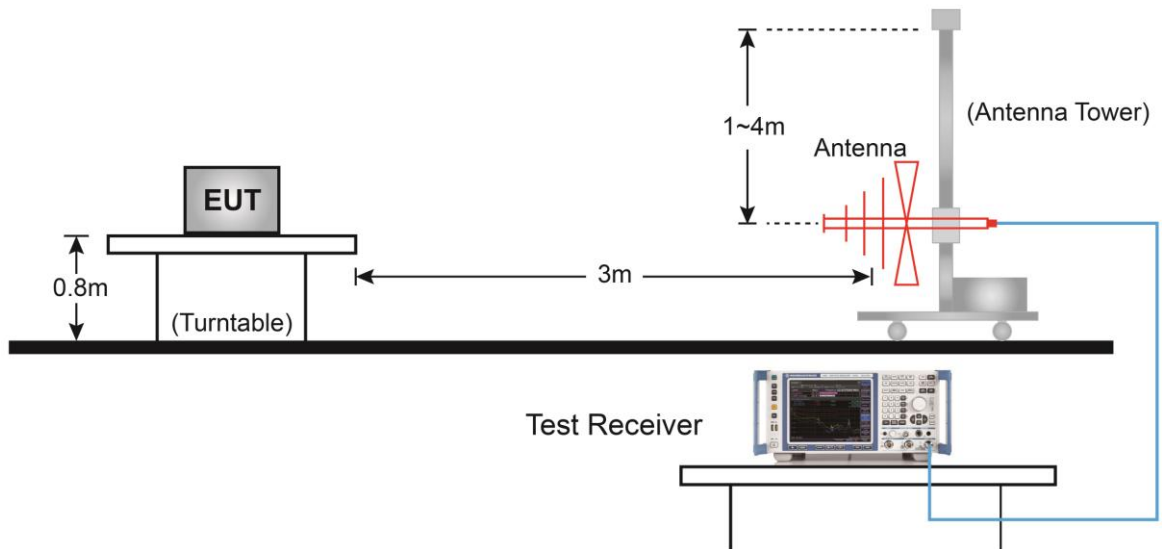

Above 1GHz Test Setup:

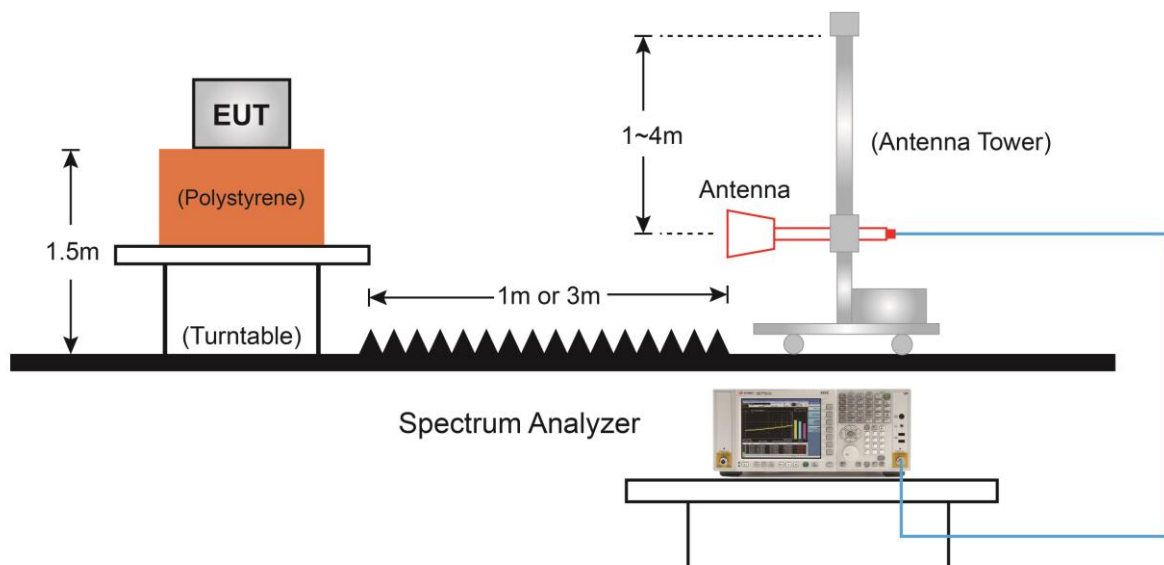

6.5.5. Test Result

Product	Wireless POS Terminal	Temperature	25°C
Test Engineer	Ternence Wang	Relative Humidity	54%
Test Site	AC1	Test Date	2019/11/16
Test Item	Radiated Spurious Emissions - GPRS850		

Frequency (MHz)	Reading Level (dBμV)	Factor (dB)	Measure Level (dBμV/m)	ERP (dBm)	ERP Limit (dBm)	Margin (dB)	Detector	Polarization
Low Channel 128 (824.20MHz)								
1646.0	66.0	-5.0	61.0	-36.41	-13.0	-23.41	Peak	Horizontal
3295.0	60.5	-1.7	58.8	-38.61	-13.0	-25.61	Peak	Horizontal
1646.0	73.9	-5.0	68.9	-28.51	-13.0	-15.51	Peak	Vertical
3295.0	58.6	-1.7	56.9	-40.51	-13.0	-27.51	Peak	Vertical
Middle Channel 189 (836.40MHz)								
1671.5	71.3	-4.8	66.5	-30.91	-13.0	-17.91	Peak	Horizontal
2513.0	65.6	-2.3	63.3	-34.11	-13.0	-21.11	Peak	Horizontal
1671.5	75.8	-4.8	71.0	-26.41	-13.0	-13.41	Peak	Vertical
2513.0	62.0	-2.3	59.7	-37.71	-13.0	-24.71	Peak	Vertical
High Channel 251 (848.80MHz)								
1697.0	70.1	-4.8	65.3	-32.11	-13.0	-19.11	Peak	Horizontal
2547.0	68.1	-2.1	66.0	-31.41	-13.0	-18.41	Peak	Horizontal
1697.0	72.9	-4.8	68.1	-29.31	-13.0	-16.31	Peak	Vertical
2547.0	63.6	-2.1	61.5	-35.91	-13.0	-22.91	Peak	Vertical

Note:

- Measure Level (dBμV/m) = Reading Level (dBμV) + Factor (dB).
Factor (dB) = Cable Loss (dB) + Antenna Factor (dB/m) - Pre_Amplifier Gain (dB).
- ERP = EIRP - 2.15 = Measure Level (dBμV/m) + 20log(D) - 104.8 - 2.15, D = 3m.
- Spurious emissions within 30-1000MHz were found more than 20dB below limit line.
- Translates in the relevant power range (1 to 0.001 W) to -13 dBm. At 1 W the specified minimum attenuation becomes 43 dB and relative to a 30 dBm (1 W) carrier becomes a limit of -13 dBm. At 0.001 W (0 dBm) the minimum attenuation is 13 dB, which again yields a limit of -13 dBm. In this way a translation of the specification from relative to absolute terms is carried out.

Product	Wireless POS Terminal	Temperature	25°C
Test Engineer	Ternence Wang	Relative Humidity	54%
Test Site	AC1	Test Date	2019/11/16
Test Item	Radiated Spurious Emissions - GPRS1900		

Frequency (MHz)	Reading Level (dBμV)	Factor (dB)	Measure Level (dBμV/m)	EIRP (dBm)	EIRP Limit (dBm)	Margin (dB)	Detector	Polarization
Low Channel 512 (1850.20MHz)								
4485.0	37.0	2.6	39.6	-55.66	-13.0	-42.66	Peak	Horizontal
6958.5	33.5	10.1	43.6	-51.66	-13.0	-38.66	Peak	Horizontal
4536.0	36.9	2.7	39.6	-55.66	-13.0	-42.66	Peak	Vertical
7825.5	34.4	11.5	45.9	-49.36	-13.0	-36.36	Peak	Vertical
Middle Channel 661 (1880.00MHz)								
5122.5	36.8	4.0	40.8	-54.46	-13.0	-41.46	Peak	Horizontal
7460.0	33.5	11.6	45.1	-50.16	-13.0	-37.16	Peak	Horizontal
6542.0	34.2	8.5	42.7	-52.56	-13.0	-39.56	Peak	Vertical
7825.5	34.5	11.5	46.0	-49.26	-13.0	-36.26	Peak	Vertical
High Channel 810 (1909.80MHz)								
5981.0	35.5	5.6	41.1	-54.16	-13.0	-41.16	Peak	Horizontal
10086.5	34.8	14.7	49.5	-45.76	-13.0	-32.76	Peak	Horizontal
6992.5	34.2	10.3	44.5	-50.76	-13.0	-37.76	Peak	Vertical
9330.0	32.8	13.5	46.3	-48.96	-13.0	-35.96	Peak	Vertical

Note:

- Measure Level (dBμV/m) = Reading Level (dBμV) + Factor (dB).
Factor (dB) = Cable Loss (dB) + Antenna Factor (dB/m) - Pre_Amplifier Gain (dB).
- EIRP (dBm) = Measure Level (dBμV/m) + 20log(D) - 104.8, D = 3m.
- Spurious emissions within 30-1000MHz were found more than 20dB below limit line.
- Translates in the relevant power range (1 to 0.001 W) to -13 dBm. At 1 W the specified minimum attenuation becomes 43 dB and relative to a 30 dBm (1 W) carrier becomes a limit of -13 dBm. At 0.001 W (0 dBm) the minimum attenuation is 13 dB, which again yields a limit of -13 dBm. In this way a translation of the specification from relative to absolute terms is carried out.

6.6. Peak-Average Ratio

6.6.1. Test Limit

For FCC Part 24.232(d):

Power measurements for transmissions by stations authorized under this section may be made either in accordance with a Commission-approved average power technique or in compliance with paragraph (e) of this section. In both instances, equipment employed must be authorized in accordance with the provisions of §24.51. In measuring transmissions in this band using an average power technique, the peak-to-average ratio (PAR) of the transmission may not exceed 13 dB.

For FCC Part 22.913(d):

The transmitter's peak-to-average power ratio (PAPR) shall not exceed 13 dB

6.6.2. Test Procedure

ANSI C63.26-2015 - Section 5.2.3.4

6.6.3. Test Setting

1. Measurement BW \geq OBW
2. Set the number of counts to a value that stabilizes the measured CCDF curve.
3. Set the measurement interval to the greater of $[10 \times (\text{number of points in sweep}) \times (\text{transmission symbol period})]$ or 1 ms.
4. Record the maximum PAPR level associated with a probability of 0.1%.

6.6.4. Test Setup

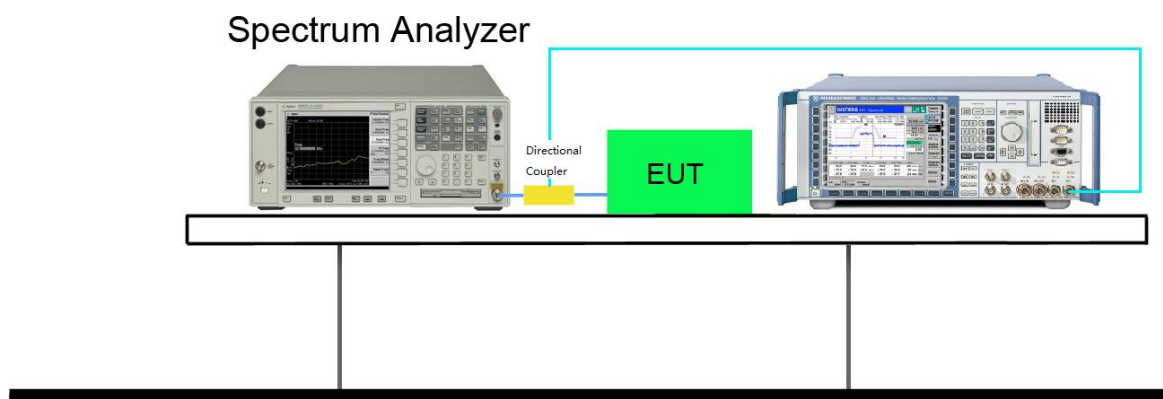

6.6.5. Test Result

Product	Wireless POS Terminal	Temperature	25°C
Test Engineer	Ternence Wang	Relative Humidity	52%
Test Site	TR3	Test Date	2019/11/16

Test Mode	Channel No.	Frequency (MHz)	Peak-Average Power Ratio (dB)	Limit (dB)	Result
GPRS850	128	824.2	6.57	< 13	Pass
	189	836.4	6.56	< 13	Pass
	251	848.8	6.56	< 13	Pass
GPRS1900	512	1850.20	8.98	< 13	Pass
	661	1880.00	9.11	< 13	Pass
	810	1909.80	8.97	< 13	Pass

GPRS850 Peak-Average Ratio

Channel 128 (824.2MHz)

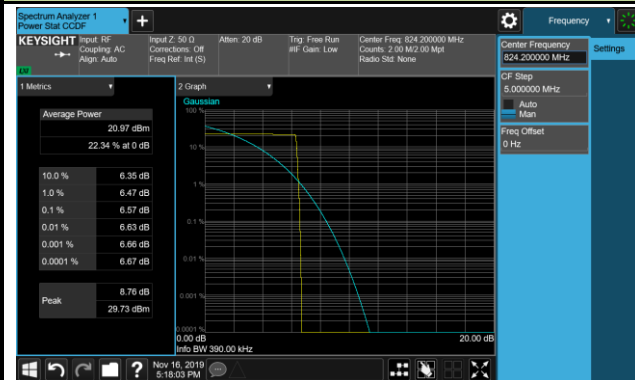

Channel 189 (836.4MHz)

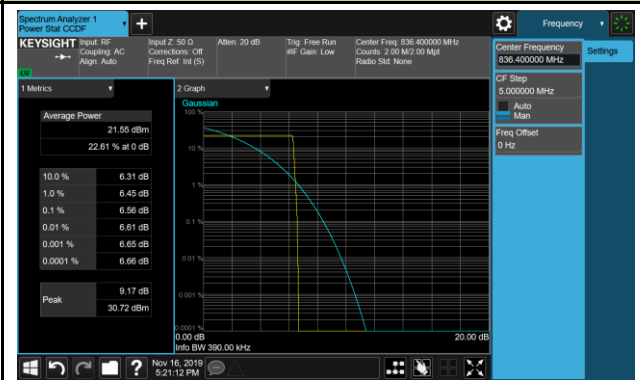

Channel 251 (848.8MHz)

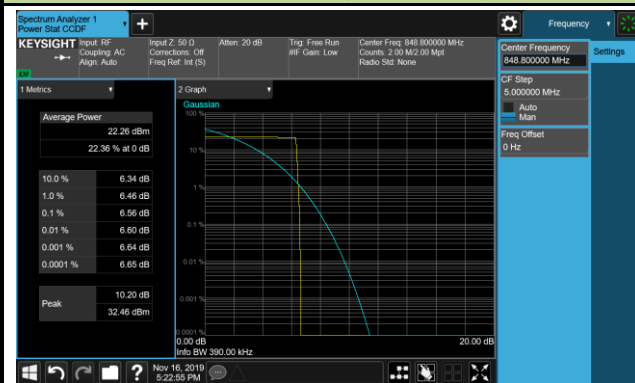

GPRS1900 Peak-Average Ratio

Channel 512 (1850.2MHz)

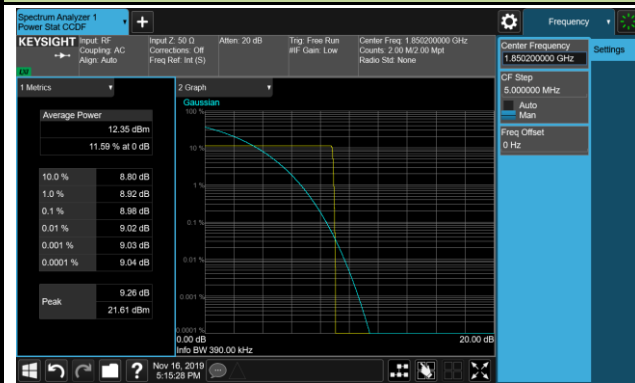

Channel 661 (1880.0MHz)



Channel 810 (1909.8MHz)

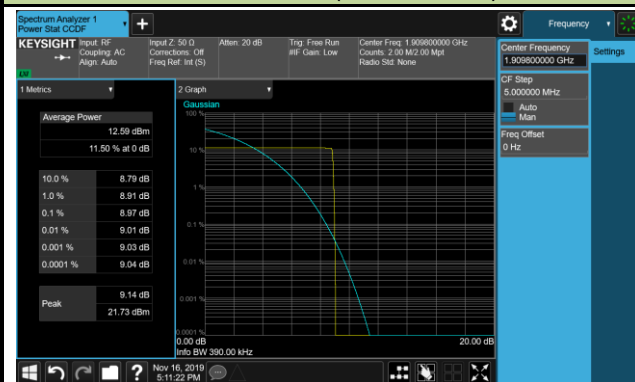

6.7. Frequency Stability

6.7.1. Test Limit

For FCC Part 24.235:

The frequency stability shall be sufficient to ensure that the fundamental emission stays within the authorized frequency block.

For FCC Part 22.355:

For mobile device ERP less than 3Watt, the must be maintained within ± 2.5 ppm.

6.7.2. Test Procedure

ANSI C63.26 - Section 5.6

6.7.3. Test Setting

Frequency Stability Under Temperature Variations:

The equipment under test was connected to an external AC or DC power supply and input rated voltage. RF output was connected to a frequency counter or spectrum analyzer via feed through attenuators. The EUT was placed inside the temperature chamber. Set the spectrum analyzer RBW low enough to obtain the desired frequency resolution and measure EUT 20°C operating frequency as reference frequency. Turn EUT off and set the chamber temperature to highest. After the temperature stabilized for approximately 30 minutes recorded the frequency. Repeat step measure with 10°C decreased per stage until the lowest temperature reached.

Frequency Stability Under Voltage Variations:

Set chamber temperature to 20°C. Use a variable AC power supply / DC power source to power the EUT and set the voltage to rated voltage. Set the spectrum analyzer RBW low enough to obtain the desired frequency resolution and recorded the frequency.

Reduce the input voltage to specify extreme voltage variation ($\pm 15\%$) and endpoint (If a product is specified to operate over a range of input voltage then the -15% variation is applied to the lowermost voltage and the $+15\%$ is applied to the uppermost voltage), record the maximum frequency change.

6.7.4. Test Setup

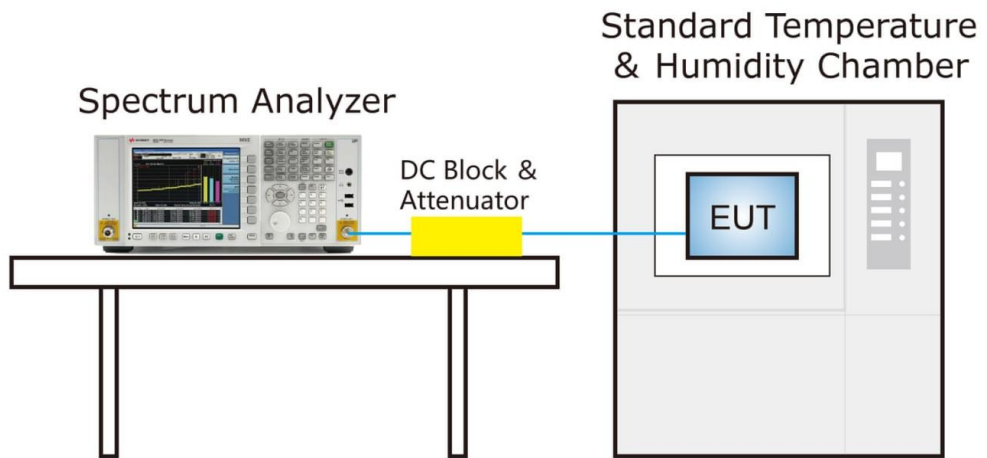

6.7.5. Test Result

Product	Wireless POS Terminal	Temperature	25°C
Test Engineer	Ternence Wang	Relative Humidity	52%
Test Site	TR3	Test Date	2019/11/16

Voltage (%)	Power (V _{DC})	TEMP (%)	Freq. Dev. (Hz)	Tolerance (ppm)	Limit (ppm)	Result
GPRS850 - Channel 189 (836.4MHz)						
100%	3.60	-30	75	0.04	-2.5 ~ 2.5	Pass
100%		-20	95	0.05	-2.5 ~ 2.5	Pass
100%		-10	105	0.06	-2.5 ~ 2.5	Pass
100%		0	60	0.03	-2.5 ~ 2.5	Pass
100%		+10	35	0.02	-2.5 ~ 2.5	Pass
100%		+20	20	0.01	-2.5 ~ 2.5	Pass
100%		+30	-40	-0.02	-2.5 ~ 2.5	Pass
100%		+40	-33	-0.02	-2.5 ~ 2.5	Pass
100%		+50	-46	-0.02	-2.5 ~ 2.5	Pass
115%	4.14	+20	25	0.01	-2.5 ~ 2.5	Pass
85%	3.06	+20	-33	-0.02	-2.5 ~ 2.5	Pass
GPRS1900 - Channel 661 (1880.0MHz)						
100%	3.60	-30	56	0.03	-2.5 ~ 2.5	Pass
100%		-20	89	0.05	-2.5 ~ 2.5	Pass
100%		-10	77	0.04	-2.5 ~ 2.5	Pass
100%		0	74	0.04	-2.5 ~ 2.5	Pass
100%		+10	32	0.02	-2.5 ~ 2.5	Pass
100%		+20	-15	-0.01	-2.5 ~ 2.5	Pass
100%		+30	-42	-0.02	-2.5 ~ 2.5	Pass
100%		+40	-33	-0.02	-2.5 ~ 2.5	Pass
100%		+50	18	0.01	-2.5 ~ 2.5	Pass
115%	4.14	+20	-35	-0.02	-2.5 ~ 2.5	Pass
85%	3.06	+20	-61	-0.03	-2.5 ~ 2.5	Pass

7. CONCLUSION

The data collected relate only the item(s) tested and show that this device compliance with all the requirements of Part 2, Part 22 and Part 24 of the FCC Rules.

————— The End —————

Appendix A - Test Setup Photograph

Refer to " 1909RSU034-UT" file.

Appendix B - EUT Photograph

Refer to “ 1909RSU034-UE” file.