

MEASUREMENT REPORT

FCC PART 15 Subpart C WLAN 802.11b/g/n

FCC ID: OWLV72
Applicant: Vanstone Electronic (Beijing) Co., Ltd.
Application Type: Certification
Product: Wireless POS Terminal
Model No.: V72
Brand Name: Aisino
FCC Classification: Digital Transmission System (DTS)
FCC Rule Part(s): Part15 Subpart C (Section 15.247)
Test Procedure(s): ANSI C63.10-2013
Test Date: November 05 ~ 26, 2019

Reviewed By:



(Sunny Sun)

Approved By:

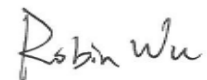

(Robin Wu)



The test results relate only to the samples tested.

This equipment has been shown to be capable of compliance with the applicable technical standards as indicated in the measurement report and was tested in accordance with the measurement procedures specified in ANSI C63.10-2013. Test results reported herein relate only to the item(s) tested.

The test report shall not be reproduced except in full without the written approval of MRT Technology (Suzhou) Co., Ltd.

Revision History

Report No.	Version	Description	Issue Date	Note
1909RSU034-U2	Rev. 01	Initial report	12-09-2019	Valid

CONTENTS

Description	Page
1. INTRODUCTION.....	6
1.1. Scope.....	6
1.2. MRT Test Location.....	6
2. PRODUCT INFORMATION.....	7
2.1. Feature of Equipment under Test	7
2.2. Product Specification Subjective to this Report	7
2.3. Working Frequencies for this report.....	8
2.4. Test Mode	8
2.5. Description of Test Software.....	8
2.6. Device Capabilities	9
2.7. Test Configuration.....	10
2.8. EMI Suppression Device(s)/Modifications.....	10
2.9. Labeling Requirements	10
3. DESCRIPTION of TEST	11
3.1. Evaluation Procedure.....	11
3.2. AC Line Conducted Emissions	11
3.3. Radiated Emissions	12
4. ANTENNA REQUIREMENTS	13
5. TEST EQUIPMENT CALIBRATION DATE.....	14
6. MEASUREMENT UNCERTAINTY.....	16
7. TEST RESULT	17
7.1. Summary.....	17
7.2. 6dB Bandwidth Measurement.....	18
7.2.1. Test Limit.....	18
7.2.2. Test Procedure used	18
7.2.3. Test Setting	18
7.2.4. Test Setup	18
7.2.5. Test Result	19
7.3. Output Power Measurement.....	23
7.3.1. Test Limit.....	23
7.3.2. Test Procedure Used.....	23
7.3.3. Test Setting	23
7.3.4. Test Setup	24

7.3.5.	Test Result	25
7.4.	Power Spectral Density Measurement	27
7.4.1.	Test Limit	27
7.4.2.	Test Procedure Used.....	27
7.4.3.	Test Setting	27
7.4.4.	Test Setup	27
7.4.5.	Test Result	28
7.5.	Conducted Band Edge and Out-of-Band Emissions	32
7.5.1.	Test Limit	32
7.5.2.	Test Procedure Used.....	32
7.5.3.	Test Setting	32
7.5.4.	Test Setup	33
7.5.5.	Test Result	34
7.6.	Radiated Spurious Emission Measurement	41
7.6.1.	Test Limit	41
7.6.2.	Test Procedure Used.....	41
7.6.3.	Test Setting	41
7.6.4.	Test Setup	43
7.6.5.	Test Result	44
7.7.	Radiated Restricted Band Edge Measurement.....	55
7.7.1.	Test Limit	55
7.7.2.	Test Procedure Used.....	56
7.7.3.	Test Setting	56
7.7.4.	Test Setup	57
7.7.5.	Test Result	58
7.8.	AC Conducted Emissions Measurement	82
7.8.1.	Test Limit	82
7.8.2.	Test Setup	82
7.8.3.	Test Result	83
8.	CONCLUSION	85
	Appendix A - Test Setup Photograph	86
	Appendix B - EUT Photograph	87

General Information

Applicant:	Vanstone Electronic (Beijing) Co., Ltd.
Applicant Address:	Room 4-18, No.25, Landianchang South Road, Haidian, Beijing, China 100097
Manufacturer:	Vanstone Electronic (Beijing) Co., Ltd.
Manufacturer Address:	Room 4-18, No.25, Landianchang South Road, Haidian, Beijing, China 100097
Test Site:	MRT Technology (Suzhou) Co., Ltd
Test Site Address:	D8 Building, No.2 Tian'edang Rd., Wuzhong Economic Development Zone, Suzhou, China

Test Facility / Accreditations

Measurements were performed at MRT Laboratory located in Tian'edang Rd., Suzhou, China.

- MRT facility is a FCC registered (MRT Reg. No. 893164) test facility with the site description report on file and has met all the requirements specified in ANSI C63.4-2014.
- MRT facility is an IC registered (MRT Reg. No. 11384A-1) test laboratory with the site description on file at Industry Canada.
- MRT facility is a VCCI registered (R-20025, G-20034, C-20020, T-20020) test laboratory with the site description on file at VCCI Council.
- MRT Lab is accredited to ISO 17025 by the American Association for Laboratory Accreditation (A2LA) under the American Association for Laboratory Accreditation Program (A2LA Cert. No. 3628.01) in EMC, Telecommunications, Radio and SAR testing.



1. INTRODUCTION

1.1. Scope

Measurement and determination of electromagnetic emissions (EMC) of radio frequency devices including intentional and/or unintentional radiators for compliance with the technical rules and regulations of the Federal Communications Commission and the Innovation, Science and Economic Development Canada and Certification and Engineering Bureau.

1.2. MRT Test Location

The map below shows the location of the MRT LABORATORY, its proximity to the Taihu Lake. These measurement tests were conducted at the MRT Technology (Suzhou) Co., Ltd. Facility located at D8 Building, No.2 Tian'edang Rd., Wuzhong Economic Development Zone, Suzhou, China. The measurement facility compliant with the test site requirements specified in ANSI C63.4-2014.



2. PRODUCT INFORMATION

2.1. Feature of Equipment under Test

Product Name:	Wireless POS Terminal
Model No.:	V72
Brand Name:	Aisino
GSM Specification:	GSM850/900/1800/1900
Wi-Fi Specification:	802.11b/g/n-HT20
NFC:	13.56MHz
Accessory	
Adapter:	Model No.: A8A-050200U-US1 Input: 100-240V ~ 50/60Hz 0.35A Output: 5V = 2.0A

2.2. Product Specification Subjective to this Report

Frequency Range:	802.11b/g/n-HT20: 2412 ~ 2462 MHz
Channel Number:	802.11b/g/n-HT20: 11
Type of Modulation:	802.11b: DSSS 802.11g/n: OFDM
Data Rate:	802.11b: 1/2/5.5/11Mbps 802.11g: 6/9/12/18/24/36/48/54Mbps 802.11n: up to 72.2Mbps
Antenna Type:	PCB Antenna
Antenna Gain:	1dBi

Note: For other features of this EUT, test report will be issued separately.

2.3. Working Frequencies for this report

802.11b/g/n-HT20

Channel	Frequency	Channel	Frequency	Channel	Frequency
01	2412 MHz	02	2417 MHz	03	2422 MHz
04	2427 MHz	05	2432 MHz	06	2437 MHz
07	2442 MHz	08	2447 MHz	09	2452 MHz
10	2457 MHz	11	2462 MHz	--	--

2.4. Test Mode

Test Mode	Mode 1: Transmit by 802.11b (1Mbps)
	Mode 2: Transmit by 802.11g (6Mbps)
	Mode 3: Transmit by 802.11n-HT20 (MCS0)

2.5. Description of Test Software

The test utility software used during testing was “Wifi Test Tool”, and the version was V1.2.0.

2.6. Device Capabilities

2.4GHz WLAN, NFC, GSM Device

The maximum achievable duty cycles for all modes were determined based on measurements performed on a spectrum analyzer in zero-span mode with RBW = 8MHz, VBW = 50MHz. The RBW and VBW were both greater than 50/T, where T is the minimum transmission duration, and the number of sweep points across T was greater than 100. The duty cycles are as follows:

Model No.	Test Mode	Duty Cycle
V72	802.11b	99.47%
	802.11g	98.58%
	802.11n-HT20	98.48%

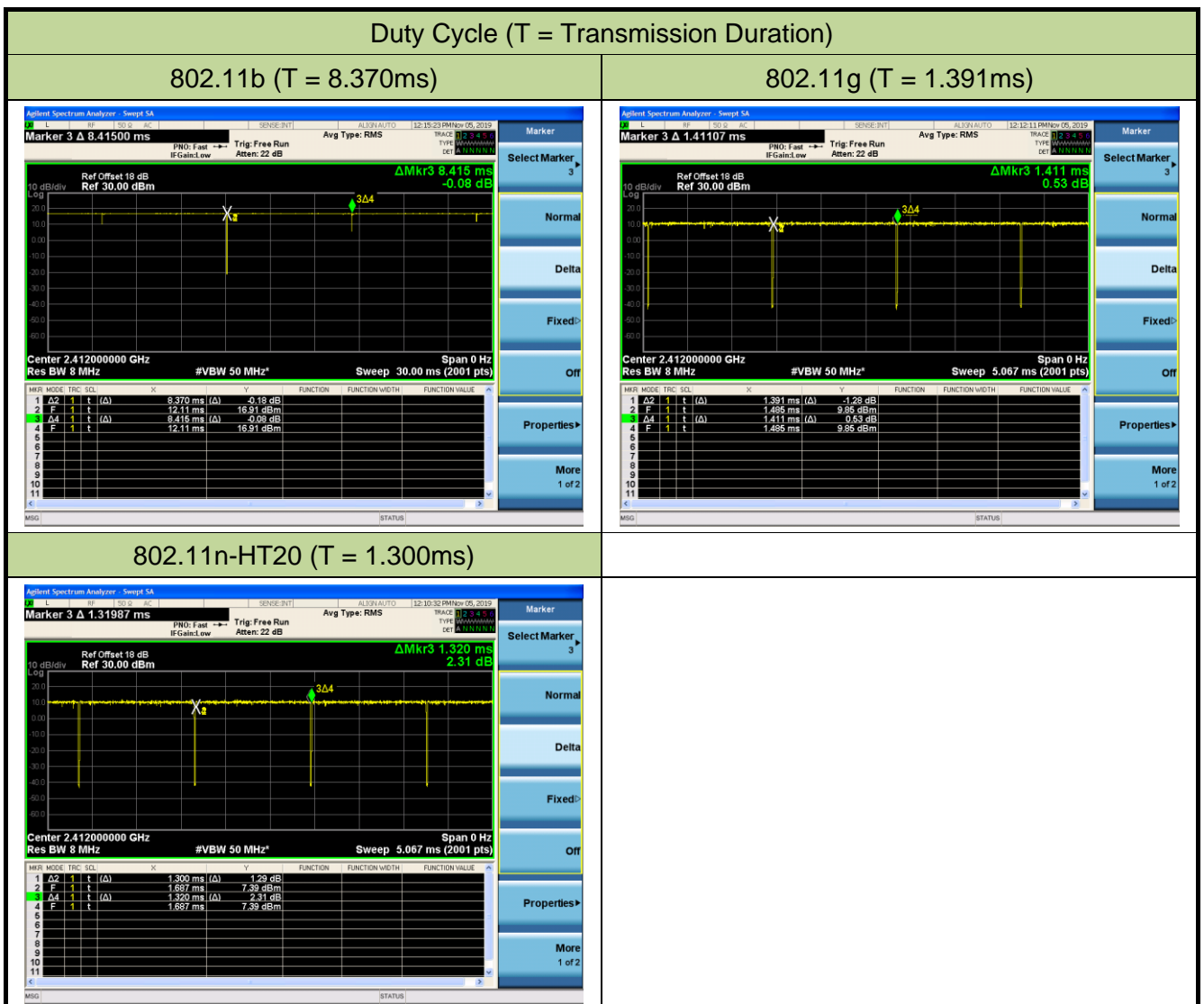

2.7. Test Configuration

This device was tested per the guidance of ANSI C63.10-2013. ANSI C63.10-2013 was used to reference the appropriate EUT setup for radiated spurious emissions testing and AC line conducted testing.

2.8. EMI Suppression Device(s)/Modifications

No EMI suppression device(s) were added and/or no modifications were made during testing.

2.9. Labeling Requirements

Per 2.1074 & 15.19; Docket 95-19

The label shall be permanently affixed at a conspicuous location on the device; instruction manual or pamphlet supplied to the user and be readily visible to the purchaser at the time of purchase. However, when the device is so small wherein placement of the label with specified statement is not practical, only the FCC ID must be displayed on the device per Section 15.19(a)(5). Please see attachment for FCC ID label and label location.

3. DESCRIPTION of TEST

3.1. Evaluation Procedure

The measurement procedures described in the American National Standard for Testing Unlicensed Wireless Devices (ANSI C63.10-2013), and the guidance was used in the measurement of the device.

Deviation from measurement procedure.....None

3.2. AC Line Conducted Emissions

The line-conducted facility is located inside an 8'x4'x4' shielded enclosure. A 1m x 2m wooden table 80cm high is placed 40cm away from the vertical wall and 80cm away from the sidewall of the shielded room. Two 10kHz-30MHz, 50Ω/50uH Line-Impedance Stabilization Networks (LISNs) are bonded to the shielded room floor. Power to the LISNs is filtered by external high-current high-insertion loss power line filters. These filters attenuate ambient signal noise from entering the measurement lines. These filters are also bonded to the shielded enclosure.

The EUT is powered from one LISN and the support equipment is powered from the second LISN. All interconnecting cables more than 1 meter were shortened to a 1 meter length by non-inductive bundling (serpentine fashion) and draped over the back edge of the test table. All cables were at least 40cm above the horizontal reference ground-plane. Power cables for support equipment were routed down to the second LISN while ensuring that that cables were not draped over the second LISN.

Sufficient time for the EUT, support equipment, and test equipment was allowed in order for them to warm up to their normal operating condition. The RF output of the LISN was connected to the receiver and exploratory measurements were made to determine the frequencies producing the maximum emission from the EUT. The receiver was scanned from 150kHz to 30MHz. The detector function was set to peak mode for exploratory measurements while the bandwidth of the analyzer was set to 9kHz. The EUT, support equipment, and interconnecting cables were arranged and manipulated to maximize each emission. Each emission was also maximized by varying: power lines, the mode of operation or data exchange speed, or support equipment whichever determined the worst-case emission. Once the worst case emissions have been identified, the one EUT cable configuration/arrangement and mode of operation that produced these emissions are used for final measurements on the same test site. The analyzer is set to CISPR quasi-peak and average detectors with a 9kHz resolution bandwidth for final measurements.

An extension cord was used to connect to a single LISN which powered by EUT. The extension cord was calibrated with LISN, the impedance and insertion loss are compliance with the requirements as stated in ANSI C63.10-2013.

3.3. Radiated Emissions

The radiated test facilities consisted of an indoor 3 meter semi-anechoic chamber used for final measurements and exploratory measurements, when necessary. The measurement area is contained within the semi-anechoic chamber which is shielded from any ambient interference. For measurements above 1GHz absorbers are arranged on the floor between the turn table and the antenna mast in such a way so as to maximize the reduction of reflections. For measurements below 1GHz, the absorbers are removed. A MF Model 210SS turntable is used for radiated measurement. It is a continuously rotatable, remote controlled, metallic turntable and 2 meters (6.56 ft.) in diameter. The turn table is flush with the raised floor of the chamber in order to maintain its function as a ground plane. An 80cm high PVC support structure is placed on top of the turntable.

For all measurements, the spectrum was scanned through all EUT azimuths and from 1 to 4 meter receive antenna height using a broadband antenna from 30MHz up to the upper frequency shown in 15.33(b)(1) depending on the highest frequency generated or used in the device or on which the device operates or tunes. For frequencies above 1GHz, linearly polarized double ridge horn antennas were used. For frequencies below 30MHz, a calibrated loop antenna was used. When exploratory measurements were necessary, they were performed at 1 meter test distance inside the semi-anechoic chamber using broadband antennas, broadband amplifiers, and spectrum analyzers to determine the frequencies and modes producing the maximum emissions. Sufficient time for the EUT, support equipment, and test equipment was allowed in order for them to warm up to their normal operating condition. The test set-up for frequencies below 1GHz was placed on top of the 0.8 meter high, 1 x 1.5 meter table; and test set-up for frequencies 1-40GHz was placed on top of the 1.5 meter high, 1 x 1.5 meter table. The EUT, support equipment, and interconnecting cables were arranged and manipulated to maximize each emission. Appropriate precaution was taken to ensure that all emissions from the EUT were maximized and investigated. The system configuration, clock speed, mode of operation or video resolution, if applicable, turntable azimuth, and receive antenna height was noted for each frequency found.

Final measurements were made in the semi-anechoic chamber using calibrated, linearly polarized broadband and horn antennas. The test setup was configured to the setup that produced the worst case emissions. The spectrum analyzer was set to investigate all frequencies required for testing to compare the highest radiated disturbances with respect to the specified limits. The turntable containing the EUT was rotated through 360 degrees and the height of the receive antenna was varied 1 to 4 meters and stopped at the azimuth and height producing the maximum emission. Each emission was maximized by changing the orientation of the EUT through three orthogonal planes and changing the polarity of the receive antenna, whichever produced the worst-case emissions. According to 3dB Beam-Width of horn antenna, the horn antenna should be always directed to the EUT when rising height.

4. ANTENNA REQUIREMENTS

Excerpt from §15.203 of the FCC Rules/Regulations:

“An intentional radiator antenna shall be designed to ensure that no antenna other than that furnished by the responsible party can be used with the device. The use of a permanently attached antenna or of an antenna that uses a unique coupling to the intentional radiator shall be considered sufficient to comply with the provisions of this section.”

- The antenna of this device is **permanently attached**.
- There are no provisions for connection to an external antenna.

Conclusion:

The unit complies with the requirement of §15.203.

5. TEST EQUIPMENT CALIBRATION DATE

Conducted Emissions - SR2

Instrument	Manufacturer	Type No.	Asset No.	Cali. Interval	Cali. Due Date
EMI Test Receiver	R&S	ESR3	MRTSUE06185	1 year	2020/04/15
Two-Line V-Network	R&S	ENV 216	MRTSUE06002	1 year	2020/06/13
Two-Line V-Network	R&S	ENV 216	MRTSUE06003	1 year	2020/06/13
Thermohygrometer	Testo	608-H1	MRTSUE06404	1 year	2020/08/08
Shielding Room	MIX-BEP	Chamber-SR2	MRTSUE06215	N/A	N/A

Radiated Emissions - AC1

Instrument	Manufacturer	Type No.	Asset No.	Cali. Interval	Cali. Due Date
EMI Test Receiver	R&S	ESR7	MRTSUE06001	1 year	2020/08/01
PXA Signal Analyzer	Keysight	9030B	MRTSUE06395	1 year	2020/09/03
Loop Antenna	Schwarzbeck	FMZB 1519	MRTSUE06025	1 year	2020/11/10
Bilog Period Antenna	Schwarzbeck	VULB 9168	MRTSUE06172	1 year	2020/03/31
Broad Band Horn Antenna	Schwarzbeck	BBHA 9120D	MRTSUE06023	1 year	2020/10/13
Broad Band Horn Antenna	Schwarzbeck	BBHA 9170	MRTSUE06024	1 year	2019/12/17
Microwave System Amplifier	Agilent	83017A	MRTSUE06076	1 year	2020/11/15
Preamplifier	Schwarzbeck	BBV 9721	MRTSUE06121	1 year	2020/06/11
Thermohygrometer	Testo	608-H1	MRTSUE06403	1 year	2020/08/08
Anechoic Chamber	TDK	Chamber-AC1	MRTSUE06212	1 year	2020/04/30

Radiated Emission - AC2

Instrument	Manufacturer	Type No.	Asset No.	Cali. Interval	Cali. Due Date
Spectrum Analyzer	Keysight	N9038A	MRTSUE06125	1 year	2020/08/01
Loop Antenna	Schwarzbeck	FMZB 1519	MRTSUE06025	1 year	2020/11/10
Bilog Period Antenna	Schwarzbeck	VULB 9162	MRTSUE06022	1 year	2020/10/13
Horn Antenna	Schwarzbeck	BBHA9120D	MRTSUE06171	1 year	2020/10/27
Broad Band Horn Antenna	Schwarzbeck	BBHA 9170	MRTSUE06024	1 year	2019/12/17
Broadband Coaxial Preamplifier	Schwarzbeck	BBV 9718	MRTSUE06176	1 year	2020/11/15
Preamplifier	Schwarzbeck	BBV 9721	MRTSUE06121	1 year	2020/06/11
Temperature/Humidity Meter	Minggao	ETH529	MRTSUE06170	1 year	2019/12/13
Anechoic Chamber	RIKEN	Chamber-AC2	MRTSUE06213	1 year	2020/04/30

Conducted Test Equipment - TR3

Instrument	Manufacturer	Type No.	Asset No.	Cali. Interval	Cali. Due Date
EXA Signal Analyzer	Agilent	N9020A	MRTSUE06106	1 year	2020/04/15
EXA Signal Analyzer	Keysight	N9010B	MRTSUE06452	1 year	2020/07/11
Signal Analyzer	R&S	FSV40	MRTSUE06218	1 year	2020/04/15
Power Meter	Agilent	U2021XA	MRTSUE06030	1 year	2020/11/18
USB wideband power sensor	Keysight	U2021XA	MRTSUE06446	1 year	2020/06/30
USB wideband power sensor	Keysight	U2021XA	MRTSUE06447	1 year	2020/06/30
Bluetooth Test Set	Anritsu	MT8852B-042	MRTSUE06389	1 year	2020/06/13
Audio Analyzer	Agilent	U8903B	MRTSUE06143	1 year	2020/06/13
Modulation Analyzer	HP	8901A	MRTSUE06098	1 year	2020/10/10
Wideband Radio Communication Tester	R&S	CMW 500	MRTSUE06243	1 year	2020/11/07
DC Power Supply	GWINSTEK	DPS-3303C	MRTSUE06064	N/A	N/A
Temperature & Humidity Chamber	BAOYT	BYH-150CL	MRTSUE06051	1 year	2020/11/07
Thermohygrometer	testo	608-H1	MRTSUE06401	1 year	2020/08/08

Software	Version	Function
EMI Software	V3	EMI Test Software

6. MEASUREMENT UNCERTAINTY

Where relevant, the following test uncertainty levels have been estimated for tests performed on the EUT as specified in CISPR 16-4-2. This uncertainty represents an expanded uncertainty expressed at approximately the 95% confidence level using a coverage factor of $k = 2$.

Conducted Emission Measurement - SR2
<p>The maximum measurement uncertainty is evaluated as:</p> <p>9kHz~150kHz: 3.84dB</p> <p>150kHz~30MHz: 3.46dB</p>
Radiated Emission Measurement - AC1
<p>The maximum measurement uncertainty is evaluated as:</p> <p>Horizontal: 30MHz~300MHz: 4.07dB</p> <p> 300MHz~1GHz: 3.63dB</p> <p> 1GHz~18GHz: 4.16dB</p> <p>Vertical: 30MHz~300MHz: 4.18dB</p> <p> 300MHz~1GHz: 3.60dB</p> <p> 1GHz~18GHz: 4.76dB</p>
Radiated Emission Measurement - AC2
<p>The maximum measurement uncertainty is evaluated as:</p> <p>Horizontal: 30MHz~300MHz: 3.75dB</p> <p> 300MHz~1GHz: 3.53dB</p> <p> 1GHz~18GHz: 4.28dB</p> <p>Vertical: 30MHz~300MHz: 3.86dB</p> <p> 300MHz~1GHz: 3.53dB</p> <p> 1GHz~18GHz: 4.33dB</p>

7. TEST RESULT

7.1. Summary

FCC Section(s)	Test Description	Test Limit	Test Condition	Test Result	Reference
15.247(a)(2)	6dB Bandwidth	$\geq 500\text{kHz}$	Conducted	Pass	Section 7.2
15.247(b)(3)	Output Power	$\leq 1\text{Watt (30dBm)}$		Pass	Section 7.3
15.247(e)	Power Spectral Density	$\leq 8\text{dBm/3kHz}$		Pass	Section 7.4
15.247(d)	Band Edge / Out-of-Band Emissions	$\leq 20\text{dBc (Peak)}$		Pass	Section 7.5
15.205 15.209	General Field Strength Limits (Restricted Bands and Radiated Emission Limits)	Emissions in restricted bands must meet the radiated limits detailed in 15.209	Radiated	Pass	Section 7.6 & 7.7
15.207	AC Conducted Emissions 150kHz - 30MHz	< FCC 15.207 limits	Line Conducted	Pass	Section 7.8

Notes:

- 1) The analyzer plots shown in this section were all taken with a correction table loaded into the analyzer. The correction table was used to account for the losses of the cables and attenuators used as part of the system to connect the EUT to the analyzer at all frequencies of interest.
- 2) All modes of operation and data rates were investigated. For radiated emission test, every axis (X, Y, Z) was also verified. The test results shown in the following sections represent the worst case emissions.

7.2. 6dB Bandwidth Measurement

7.2.1. Test Limit

The minimum 6dB bandwidth shall be at least 500 kHz.

7.2.2. Test Procedure used

ANSI C63.10 Section 11.8

7.2.3. Test Setting

1. The Spectrum's automatic bandwidth measurement capability was used to perform the 6dB bandwidth measurement. The "X" dB bandwidth parameter was set to $X = 6$. The bandwidth measurement was not influenced by any intermediate power nulls in the fundamental emission.
2. Set RBW = 100 kHz
3. $VBW \geq 3 \times RBW$
4. Detector = Peak
5. Trace mode = max hold
6. Sweep = auto couple
7. Allow the trace was allowed to stabilize

7.2.4. Test Setup

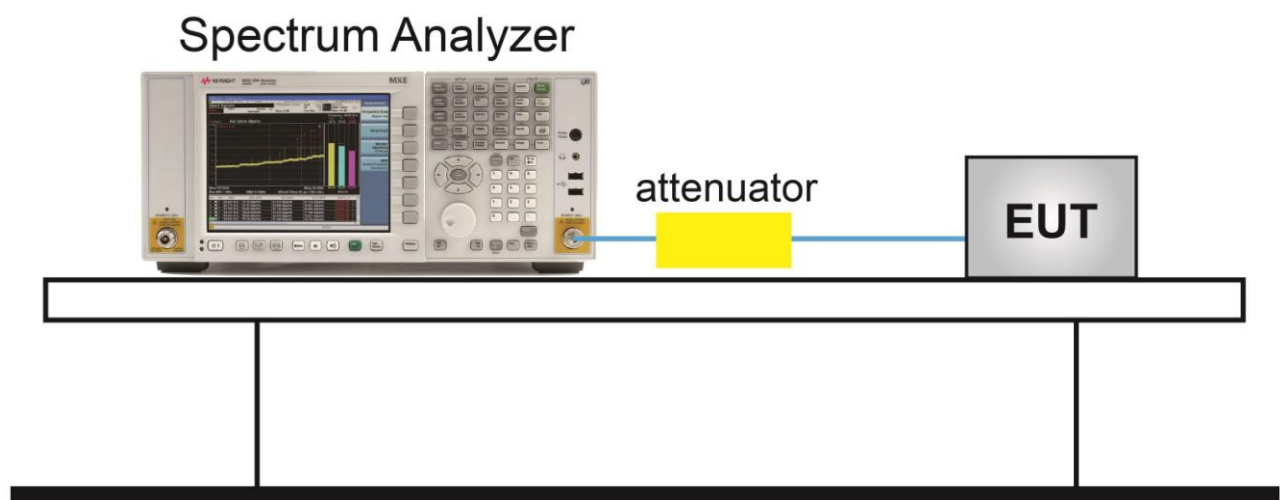

7.2.5. Test Result

Product	Wireless POS Terminal	Temperature	23°C
Test Engineer	Flay Yang	Relative Humidity	54%
Test Site	TR3	Test Date	2019/11/22

Test Mode	Data Rate / MCS	Channel No.	Frequency (MHz)	6dB Bandwidth (MHz)	Limit (MHz)	Result
802.11b	1Mbps	01	2412	12.56	≥ 0.5	Pass
802.11b	1Mbps	06	2437	12.54	≥ 0.5	Pass
802.11b	1Mbps	11	2462	12.56	≥ 0.5	Pass
802.11g	6Mbps	01	2412	16.39	≥ 0.5	Pass
802.11g	6Mbps	06	2437	16.42	≥ 0.5	Pass
802.11g	6Mbps	11	2462	16.41	≥ 0.5	Pass
802.11n-HT20	MCS0	01	2412	17.09	≥ 0.5	Pass
802.11n-HT20	MCS0	06	2437	17.13	≥ 0.5	Pass
802.11n-HT20	MCS0	11	2462	17.08	≥ 0.5	Pass

802.11b 6dB Bandwidth

Channel 01 (2412MHz)

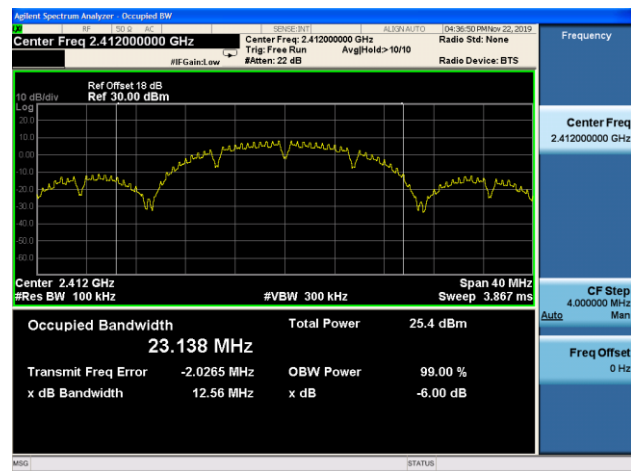

Channel 06 (2437MHz)

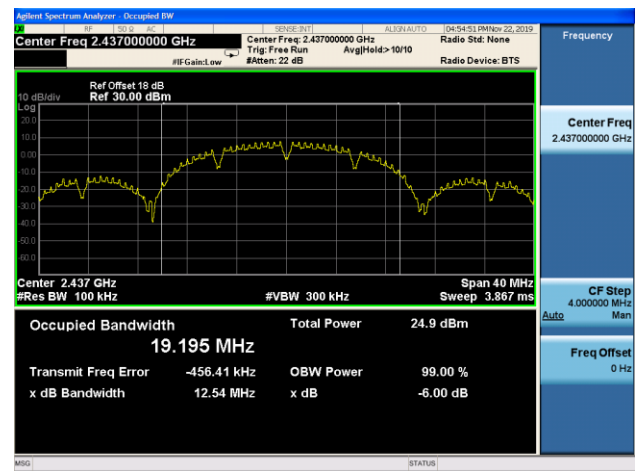

Channel 11 (2462MHz)

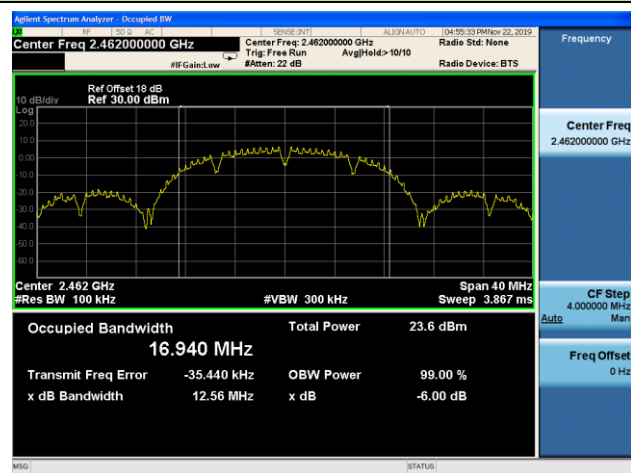

802.11g 6dB Bandwidth

Channel 01 (2412MHz)

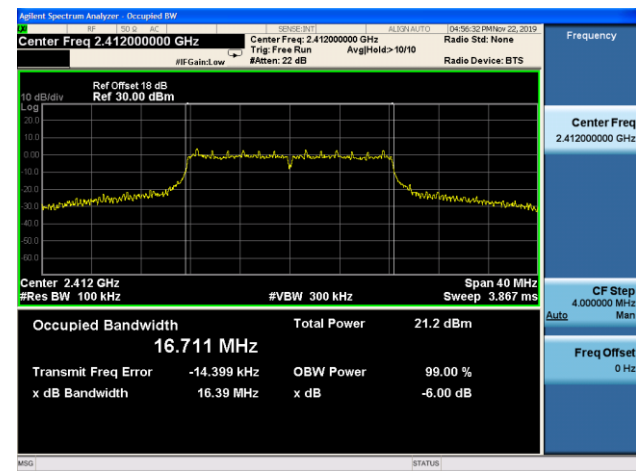

Channel 06 (2437MHz)

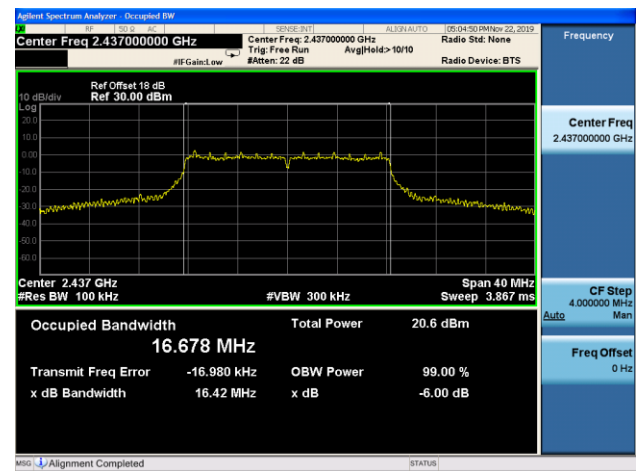

Channel 11 (2462MHz)

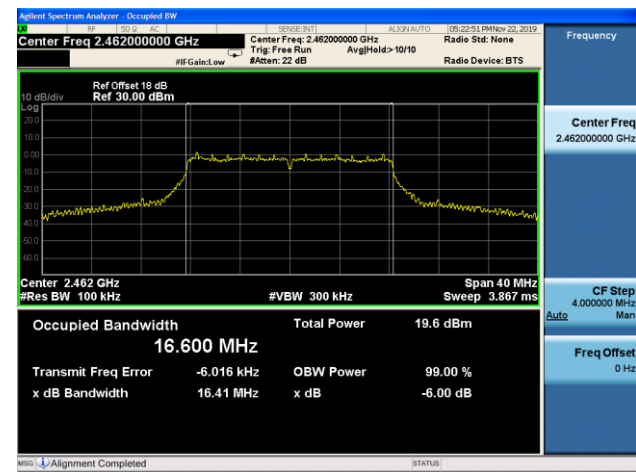

802.11n-HT20 6dB Bandwidth

Channel 01 (2412MHz)

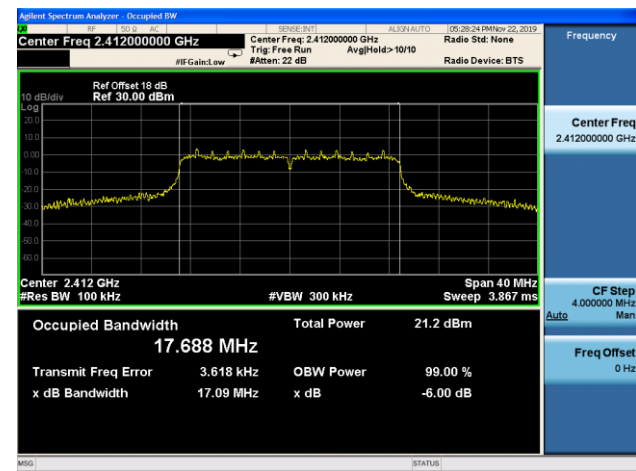

Channel 06 (2437MHz)

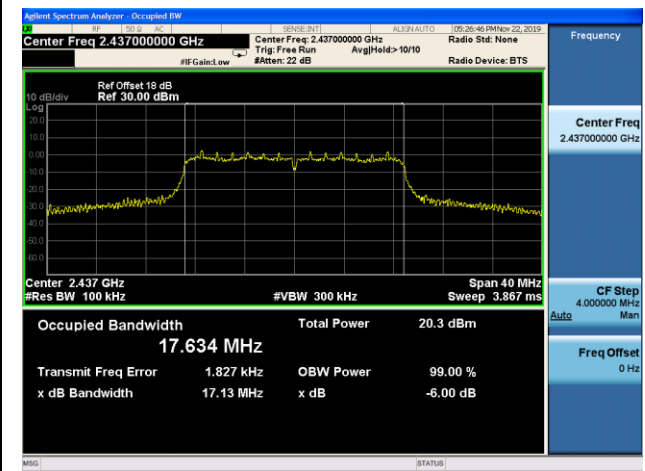

Channel 11 (2462MHz)

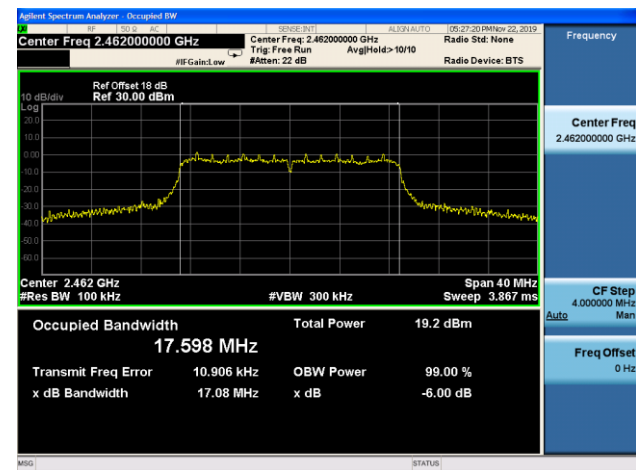

7.3. Output Power Measurement

7.3.1. Test Limit

The maximum output power shall be less 1 Watt (30dBm).

The conducted output power limit specified in paragraph FCC Part 15.247(b) of this section is based on the use of antennas with directional gains that do not exceed 6 dBi. If transmitting antennas of directional gain greater than 6 dBi are used, the conducted output power from the intentional radiator shall be reduced below the stated values in paragraphs FCC Part 15.247(b)(3) of this section, as appropriate, by the amount in dB that the directional gain of the antenna exceeds 6 dBi.

7.3.2. Test Procedure Used

ANSI C63.10 - Section 11.9.1.3

ANSI C63.10 - Section 11.9.2.3.2

7.3.3. Test Setting

PKPM1 Peak Power Meter Method

The maximum peak conducted output power may be measured using a broadband peak RF power meter. The power meter shall have a video bandwidth that is greater than or equal to the DTS bandwidth and shall use a fast-responding diode detector.

Method AVGPM-G

Method AVGPM-G is a measurement using a gated RF average power meter.

Alternatively, measurements may be performed using a wideband gated RF power meter provided that the gate parameters are adjusted such that the power is measured only when the EUT is transmitting at its maximum power control level. Because the measurement is made only during the ON time of the transmitter, no duty cycle correction factor is required.

7.3.4. Test Setup

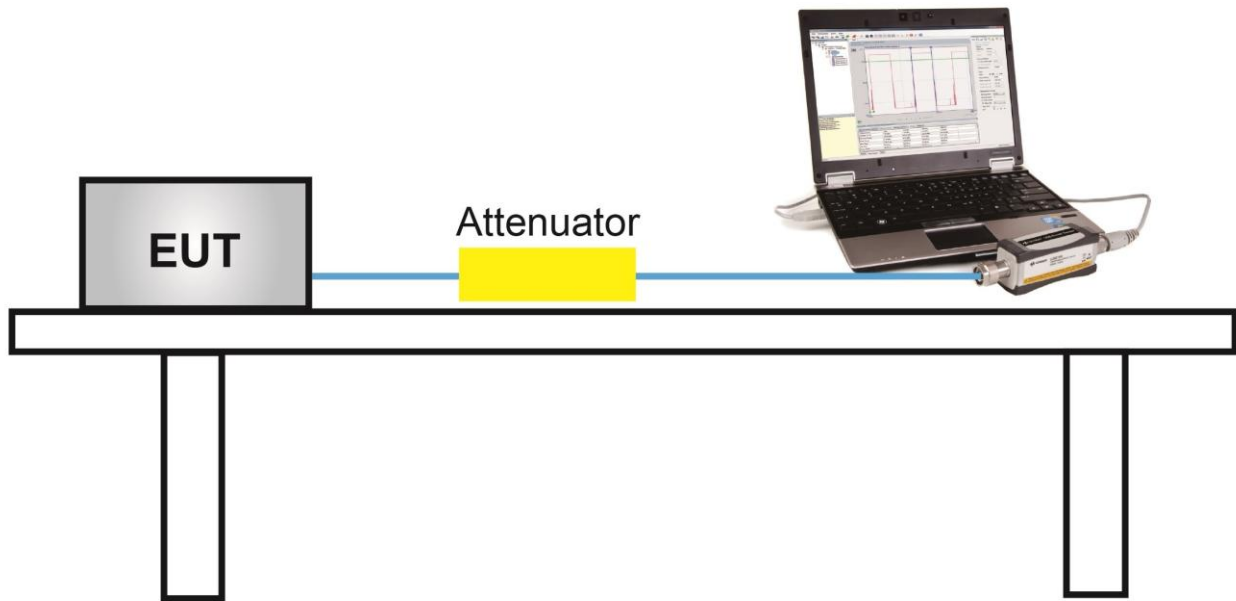

7.3.5. Test Result

Power output test was verified over all data rates of each mode shown as below table, and then choose the maximum power output (gray marker) for final test of each channel.

Pre-Test RF Output Power at various data rates:

Test Mode	Bandwidth (MHz)	Channel No.	Frequency (MHz)	Data Rate / Mbps	Average Power (dBm)
802.11b	20	06	2437	1Mbps	17.33
				5.5Mbps	17.01
				11Mbps	16.73
802.11g	20	06	2437	6Mbps	12.68
				24Mbps	12.19
				54Mbps	11.80
802.11n	20	06	2437	MCS0	12.74
				MCS3	12.42
				MCS7	12.13

Product	Wireless POS Terminal	Temperature	25°C
Test Engineer	Flay Yang	Relative Humidity	56%
Test Site	TR3	Test Date	2019/11/22

Test Mode	Data Rate/MCS	Channel No.	Freq. (MHz)	Output Power (dBm)	Limit (dBm)	Result
Test Result of Peak Output Power						
802.11b	1Mbps	01	2412	19.27	≤ 30.00	Pass
802.11b	1Mbps	06	2437	19.10	≤ 30.00	Pass
802.11b	1Mbps	11	2462	18.19	≤ 30.00	Pass
802.11g	6Mbps	01	2412	19.46	≤ 30.00	Pass
802.11g	6Mbps	06	2437	19.14	≤ 30.00	Pass
802.11g	6Mbps	11	2462	18.62	≤ 30.00	Pass
802.11n-HT20	MCS0	01	2412	19.35	≤ 30.00	Pass
802.11n-HT20	MCS0	06	2437	19.24	≤ 30.00	Pass
802.11n-HT20	MCS0	11	2462	18.94	≤ 30.00	Pass
Test Result of Average Output Power (Reporting Only)						
802.11b	1Mbps	01	2412	17.53	≤ 30.00	Pass
802.11b	1Mbps	06	2437	17.33	≤ 30.00	Pass
802.11b	1Mbps	11	2462	15.96	≤ 30.00	Pass
802.11g	6Mbps	01	2412	13.53	≤ 30.00	Pass
802.11g	6Mbps	06	2437	12.68	≤ 30.00	Pass
802.11g	6Mbps	11	2462	11.58	≤ 30.00	Pass
802.11n-HT20	MCS0	01	2412	13.37	≤ 30.00	Pass
802.11n-HT20	MCS0	06	2437	12.74	≤ 30.00	Pass
802.11n-HT20	MCS0	11	2462	11.39	≤ 30.00	Pass

7.4. Power Spectral Density Measurement

7.4.1. Test Limit

The maximum permissible power spectral density is 8dBm in any 3 kHz band.

The same method of determining the conducted output power shall be used to determine the power spectral density.

7.4.2. Test Procedure Used

ANSI C63.10 - Section 11.10.2

7.4.3. Test Setting

1. Analyzer was set to the center frequency of the DTS channel under investigation
2. Span = 1.5 times the DTS channel bandwidth
3. RBW = 3kHz
4. VBW = 10kHz
5. Detector = peak
6. Sweep time = auto couple
7. Trace mode = max hold
8. Trace was allowed to stabilize

7.4.4. Test Setup

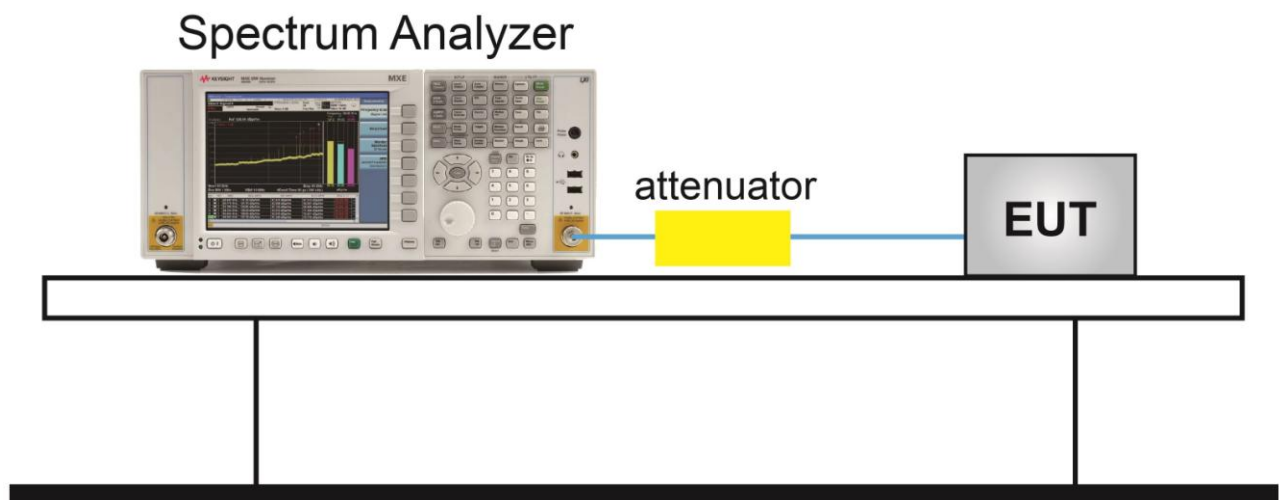

7.4.5. Test Result

Product	Wireless POS Terminal	Temperature	23°C
Test Engineer	Flay Yang	Relative Humidity	54%
Test Site	TR3	Test Date	2019/11/22

Test Mode	Data Rate/ MCS	Channel No.	Freq. (MHz)	PKPSD (dBm/ 3kHz)	Limit (dBm/ 3kHz)	Result
802.11b	1Mbps	01	2412	-6.37	≤ 8	Pass
802.11b	1Mbps	06	2437	-6.62	≤ 8	Pass
802.11b	1Mbps	11	2462	-7.64	≤ 8	Pass
802.11g	6Mbps	01	2412	-11.48	≤ 8	Pass
802.11g	6Mbps	06	2437	-12.04	≤ 8	Pass
802.11g	6Mbps	11	2462	-13.05	≤ 8	Pass
802.11n-HT20	MCS0	01	2412	-10.84	≤ 8	Pass
802.11n-HT20	MCS0	06	2437	-12.05	≤ 8	Pass
802.11n-HT20	MCS0	11	2462	-12.09	≤ 8	Pass

802.11b PKPSD

Channel 01 (2412MHz)

Channel 06 (2437MHz)



Channel 11 (2462MHz)

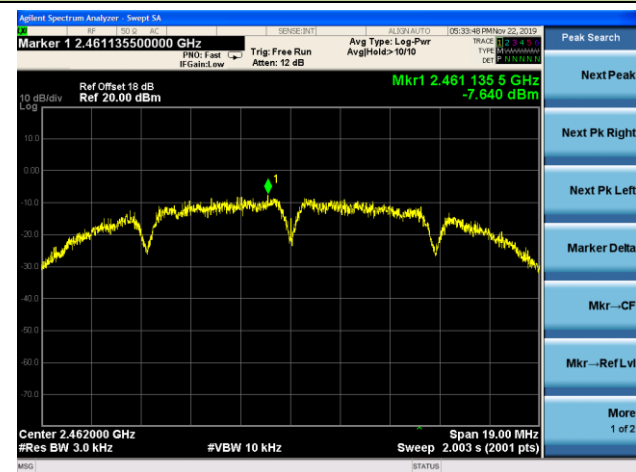

802.11g PKPSD

Channel 01 (2412MHz)

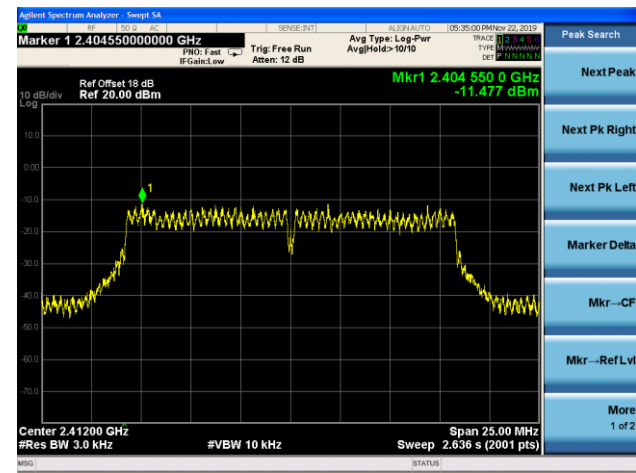

Channel 06 (2437MHz)

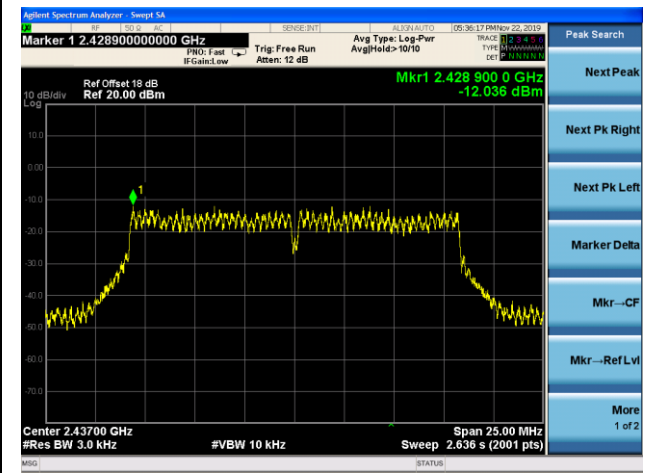

Channel 11 (2462MHz)

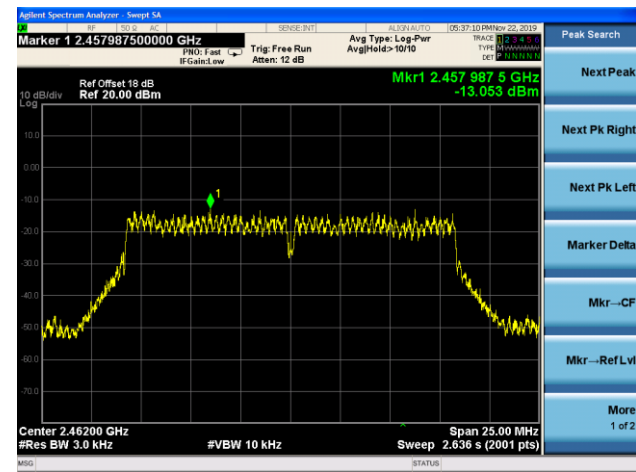

802.11n-HT20 PKPSD

Channel 01 (2412MHz)

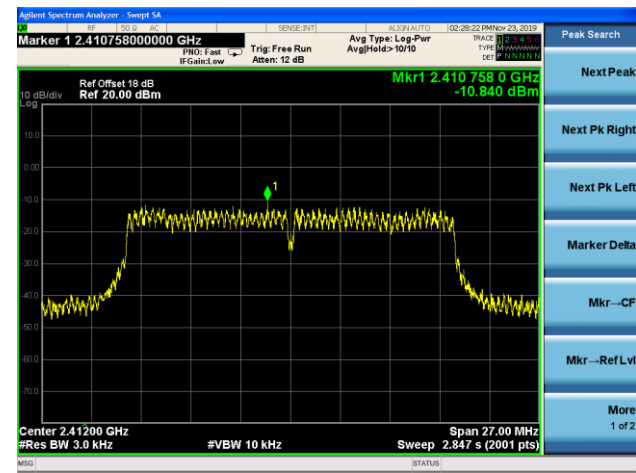

Channel 06 (2437MHz)

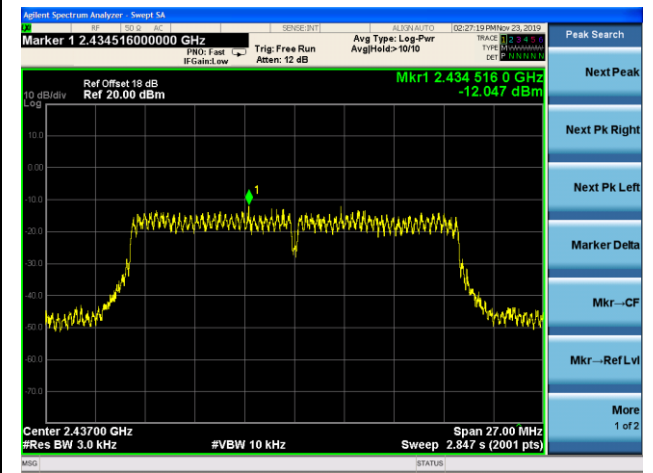

Channel 11 (2462MHz)

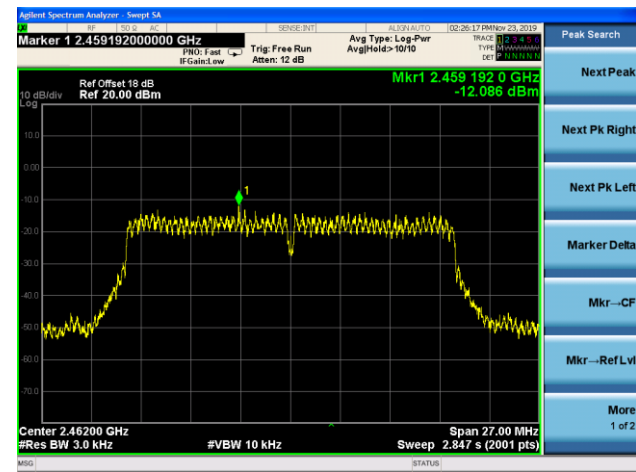

7.5. Conducted Band Edge and Out-of-Band Emissions

7.5.1. Test Limit

The limit for out-of-band spurious emissions at the band edge is 20dB below the fundamental emission level, as determined from the in-band power measurement of the DTS channel performed in a 100 kHz bandwidth per the PSD procedure.

7.5.2. Test Procedure Used

ANSI C63.10 Section 11.11

7.5.3. Test Setting

Reference level measurement

1. Set instrument center frequency to DTS channel center frequency
2. Set the span to ≥ 1.5 times the DTS bandwidth
3. Set the RBW = 100 kHz
4. Set the VBW $\geq 3 \times$ RBW
5. Detector = peak
6. Sweep time = auto couple
7. Trace mode = max hold
8. Allow trace to fully stabilize

Emission level measurement

1. Set the center frequency and span to encompass frequency range to be measured
2. RBW = 1.3MHz
3. VBW = 4MHz
4. Detector = Peak
5. Trace mode = max hold
6. Sweep time = auto couple
7. The trace was allowed to stabilize

Test Notes

1. RBW was set to 1.3MHz rather than 100 kHz in order to increase the measurement speed.
2. The display line shown in the following plots denotes the limit at 30dB below the fundamental emission level measured in a 100 kHz bandwidth. However, since the traces in the following plots are measured with a 1.3MHz RBW, the display line may not necessarily appear to be 30dB below the level of the fundamental in a 1.3MHz bandwidth.
3. For plots showing conducted spurious emissions near the limit, the frequencies were investigated with a reduced RBW to ensure that no emissions were present.

7.5.4. Test Setup

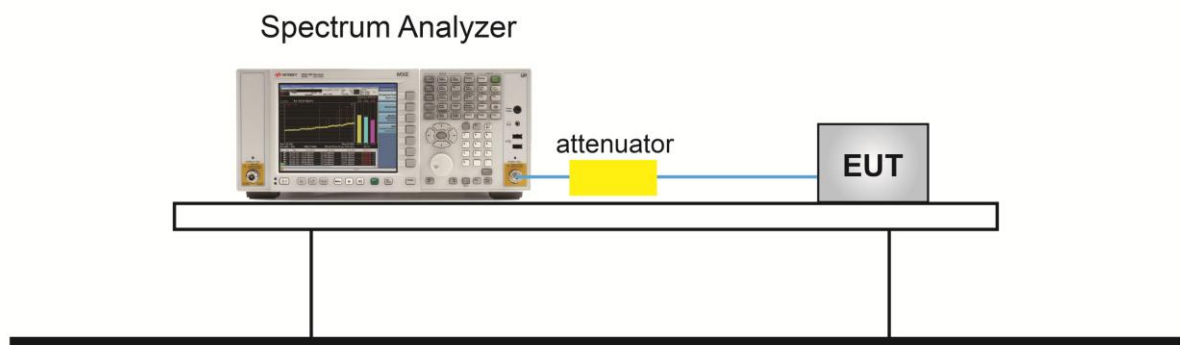

7.5.5. Test Result

Product	Wireless POS Terminal	Temperature	23°C
Test Engineer	Flay Yang	Relative Humidity	54%
Test Site	TR3	Test Date	2019/11/23

Test Mode	Data Rate / MCS	Channel No.	Frequency (MHz)	Limit (dBc)	Result
802.11b	1Mbps	01	2412	20	Pass
802.11b	1Mbps	06	2437	20	Pass
802.11b	1Mbps	11	2462	20	Pass
802.11g	6Mbps	01	2412	20	Pass
802.11g	6Mbps	06	2437	20	Pass
802.11g	6Mbps	11	2462	20	Pass
802.11n-HT20	MCS0	01	2412	20	Pass
802.11n-HT20	MCS0	06	2437	20	Pass
802.11n-HT20	MCS0	11	2462	20	Pass

802.11b Out-of-Band Emissions

Channel 01 (2412MHz)

100kHz PSD reference Level

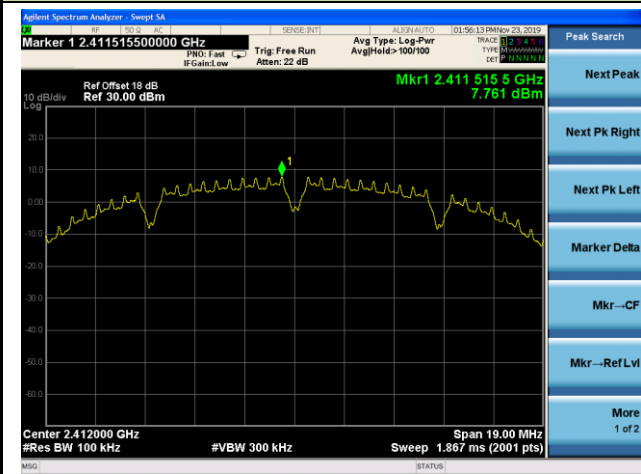

Low Band Edge

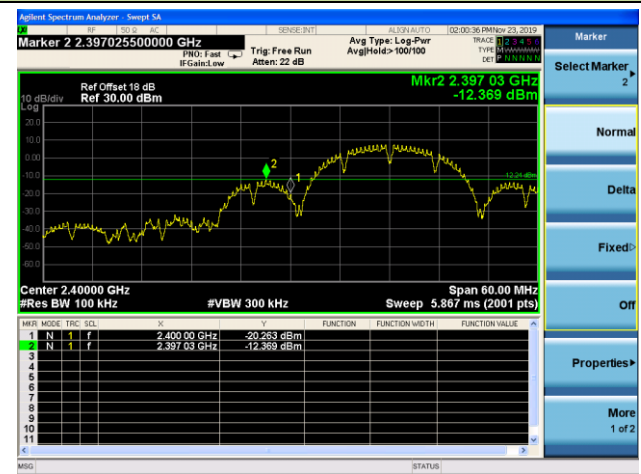

Spurious Emission

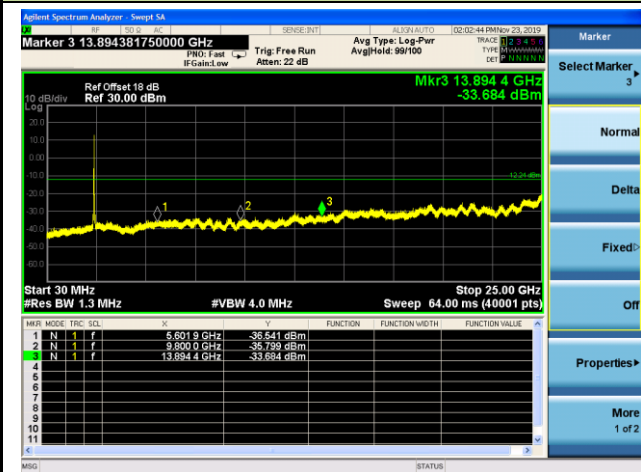

Channel 06 (2437MHz)

100kHz PSD reference Level

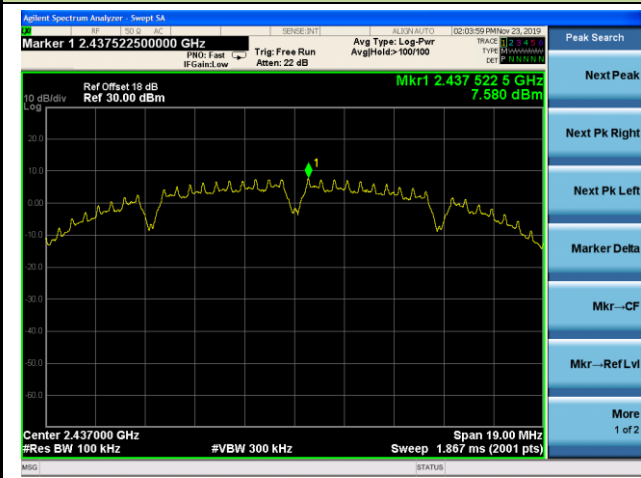

Spurious Emission

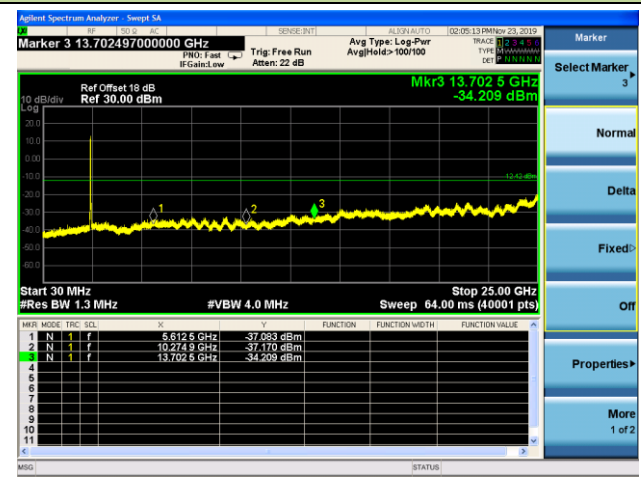

802.11b Out-of-Band Emissions

Channel 11 (2462MHz)

100kHz PSD reference Level

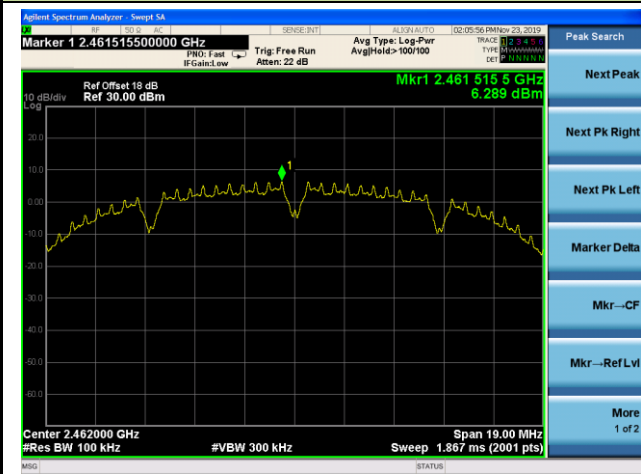

High Band Edge

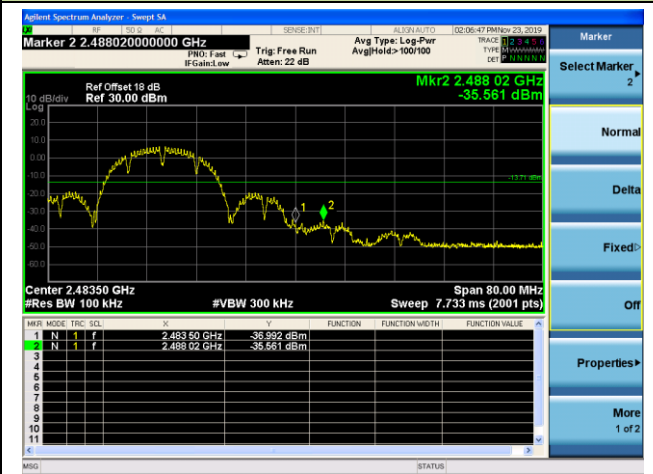

Spurious Emission

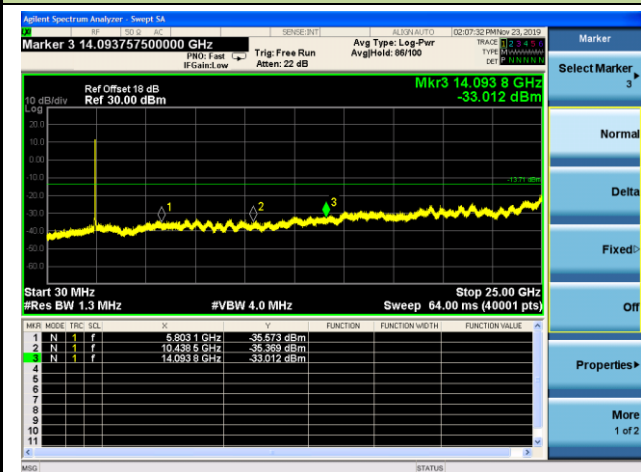

802.11g Out-of-Band Emissions

Channel 01 (2412MHz)

100kHz PSD reference Level

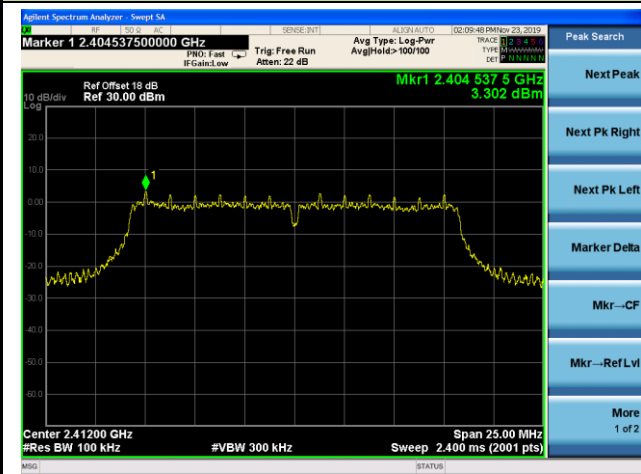

Low Band Edge

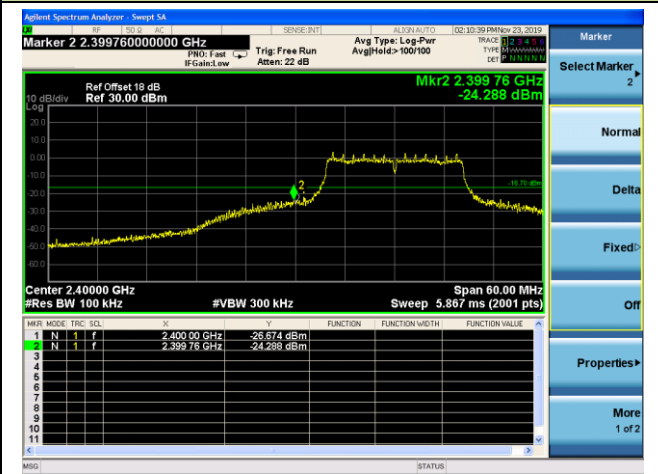

Spurious Emission

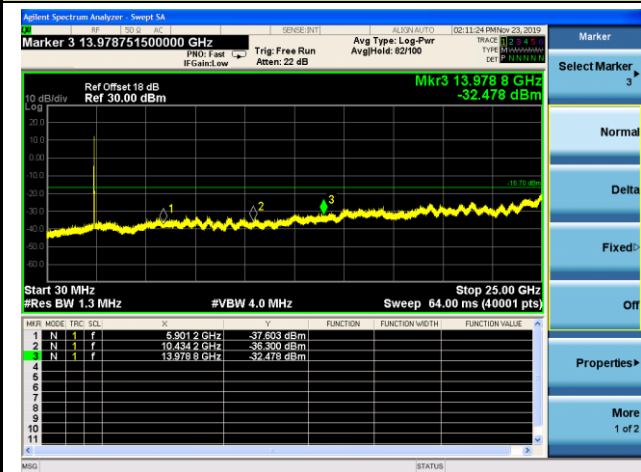

Channel 06 (2437MHz)

100kHz PSD reference Level

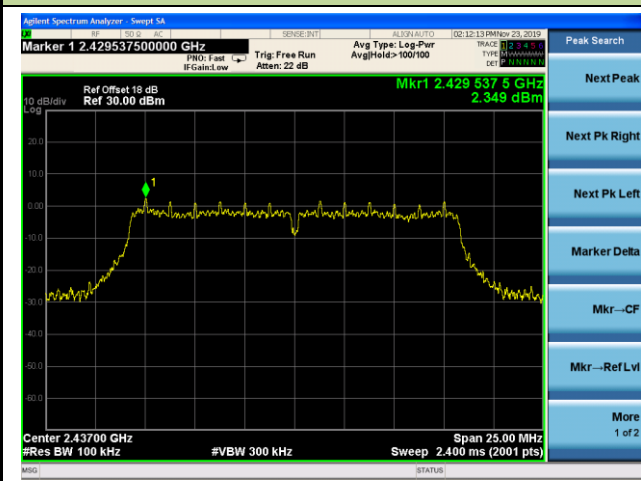

Spurious Emission

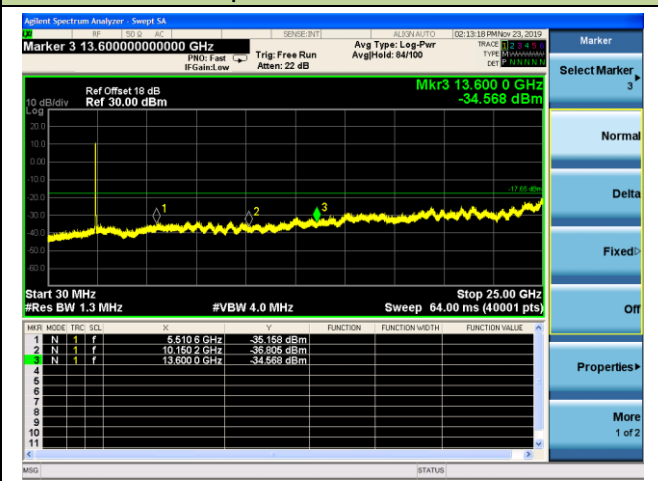

802.11g Out-of-Band Emissions

Channel 11 (2462MHz)

100kHz PSD reference Level

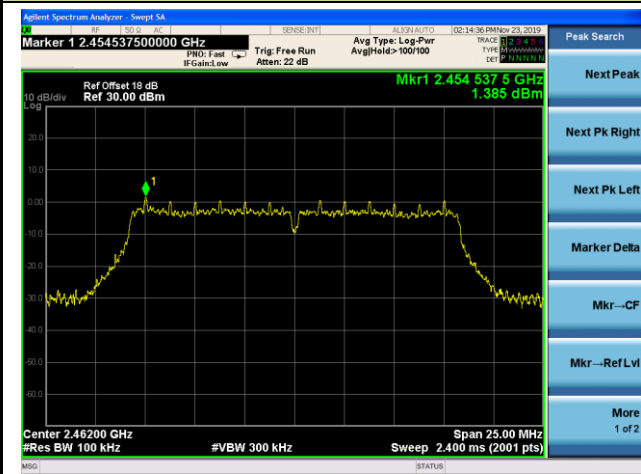

High Band Edge

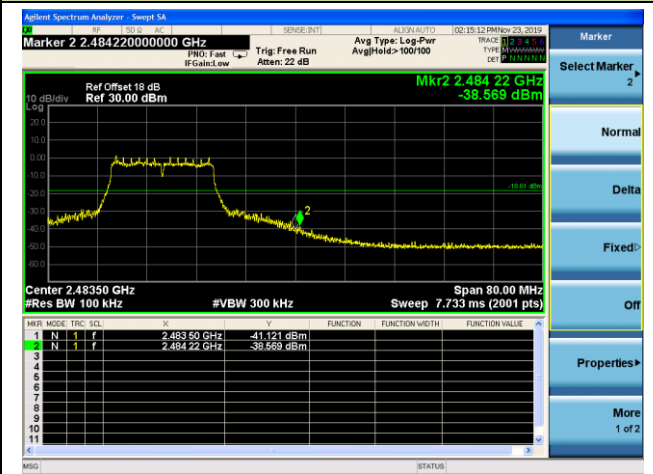

Spurious Emission

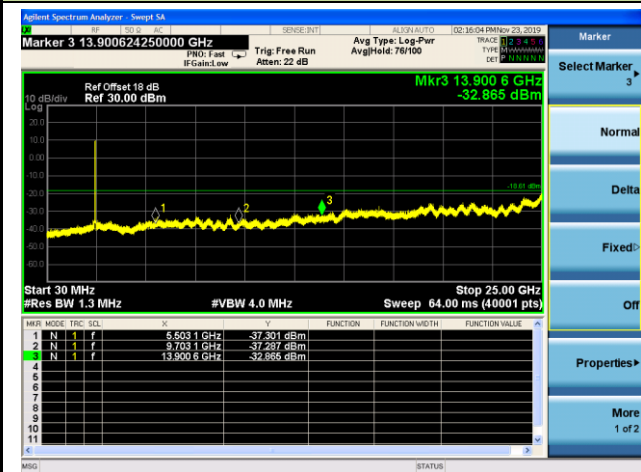

802.11n-HT20 Out-of-Band Emissions

Channel 01 (2412MHz)

100kHz PSD reference Level

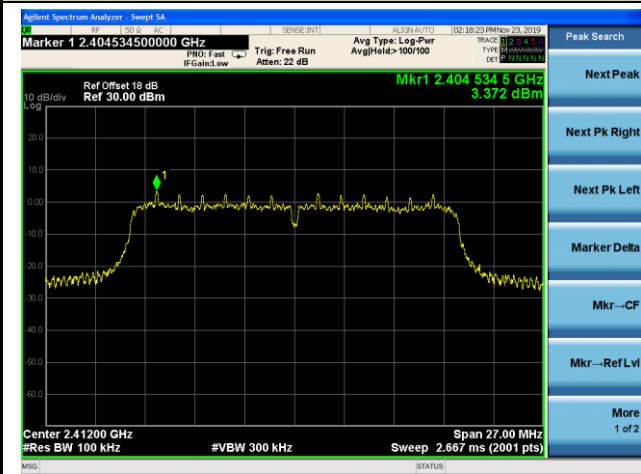

Low Band Edge

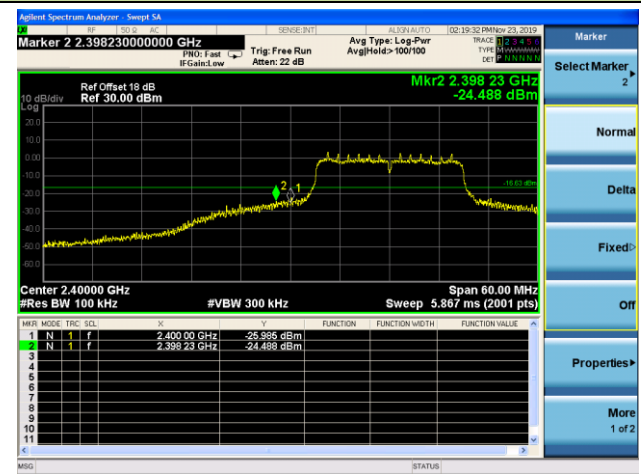

Spurious Emission

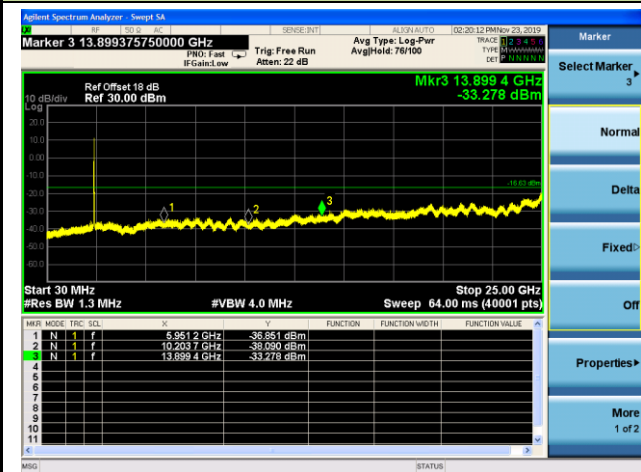

Channel 06 (2437MHz)

100kHz PSD reference Level

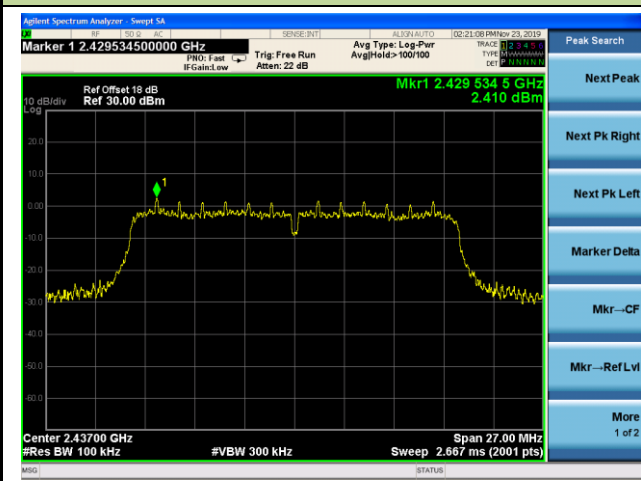

Spurious Emission

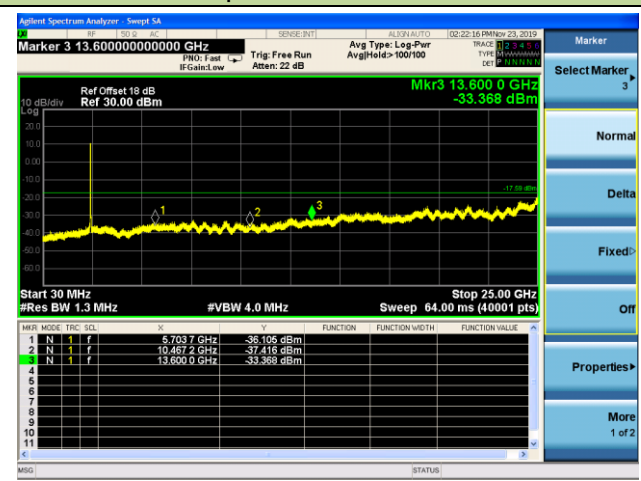

802.11n-HT20 Out-of-Band Emissions

Channel 11 (2462MHz)

100kHz PSD reference Level

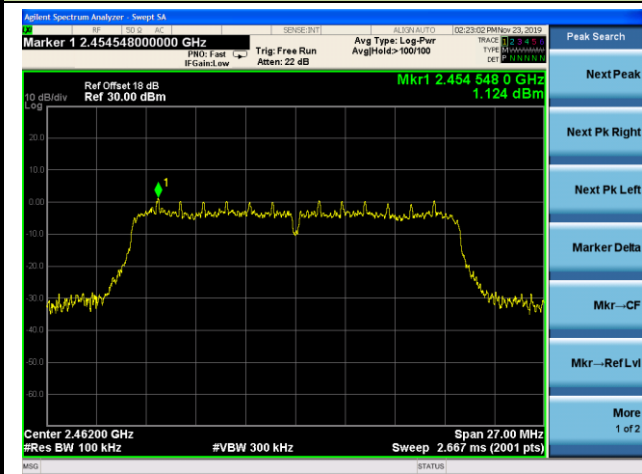

High Band Edge

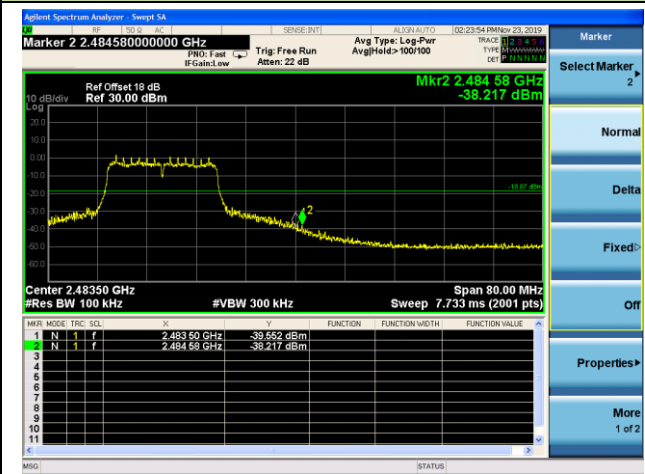

Spurious Emission

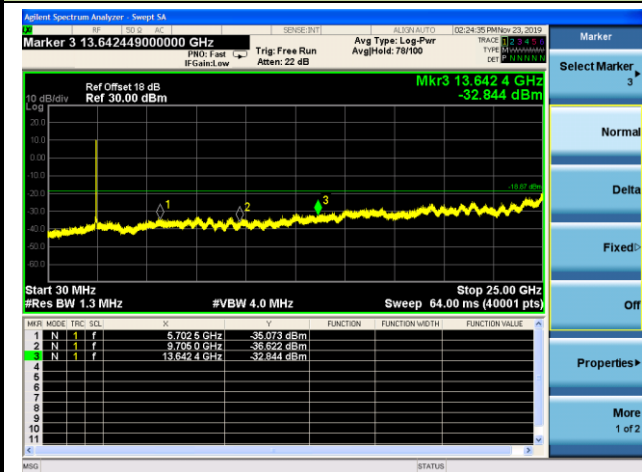

7.6. Radiated Spurious Emission Measurement

7.6.1. Test Limit

All out of band emissions appearing in a restricted band as specified in Section 15.205 of the Title 47 CFR must not exceed the limits shown in Table per Section 15.209.

FCC Part 15 Subpart C Paragraph 15.209		
Frequency [MHz]	Field Strength [uV/m]	Measured Distance [Meters]
0.009 - 0.490	2400/F (kHz)	300
0.490 - 1.705	24000/F (kHz)	30
1.705 - 30	30	30
30 - 88	100	3
88 - 216	150	3
216 - 960	200	3
Above 960	500	3

7.6.2. Test Procedure Used

ANSI C63.10 Section 6.3 (General Requirements)

ANSI C63.10 Section 6.4 (Standard test method below 30MHz)

ANSI C63.10 Section 6.5 (Standard test method above 30MHz to 1GHz)

ANSI C63.10 Section 6.6 (Standard test method above 1GHz)

7.6.3. Test Setting

Quasi-Peak Measurements below 1GHz

1. Analyzer center frequency was set to the frequency of the radiated spurious emission of interest
2. Span was set greater than 1MHz
3. RBW = as specified in Table 1
4. Detector = CISPR quasi-peak or average
5. Sweep time = auto couple
6. Trace was allowed to stabilize

Table 1 - RBW as a function of frequency

Frequency	RBW
9 ~ 150 kHz	200 ~ 300 Hz
0.15 ~ 30 MHz	9 ~ 10 kHz
30 ~ 1000 MHz	100 ~ 120 kHz
> 1000 MHz	1 MHz

Peak Measurements above 1GHz

1. Analyzer center frequency was set to the frequency of the radiated spurious emission of interest
2. RBW = 1MHz
3. VBW = 3MHz
4. Detector = peak
5. Sweep time = auto couple
6. Trace mode = max hold
7. Trace was allowed to stabilize

Average Measurements above 1GHz (Method VB)

1. Analyzer center frequency was set to the frequency of the radiated spurious emission of interest
2. RBW = 1MHz
3. VBW; If the EUT is configured to transmit with duty cycle $\geq 98\%$, set VBW = 10 Hz.
If the EUT duty cycle is $< 98\%$, set $VBW \geq 1/T$. T is the minimum transmission duration.
4. Detector = Peak
5. Sweep time = auto
6. Trace mode = max hold
7. Trace was allowed to stabilize

7.6.4. Test Setup

Below 1GHz Test Setup:

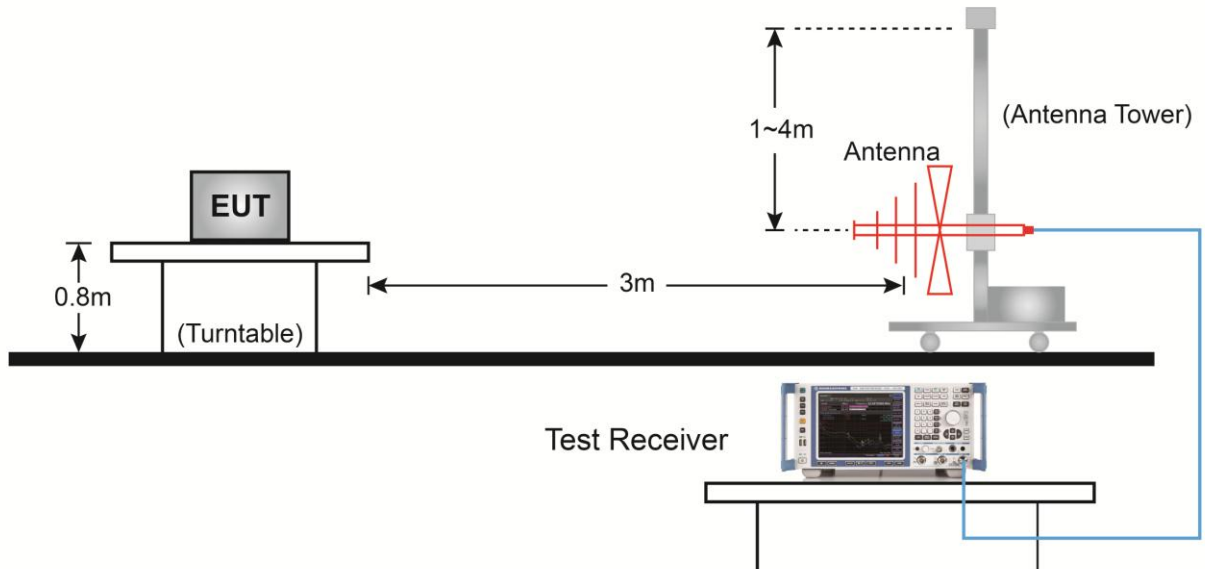

Above 1GHz Test Setup:

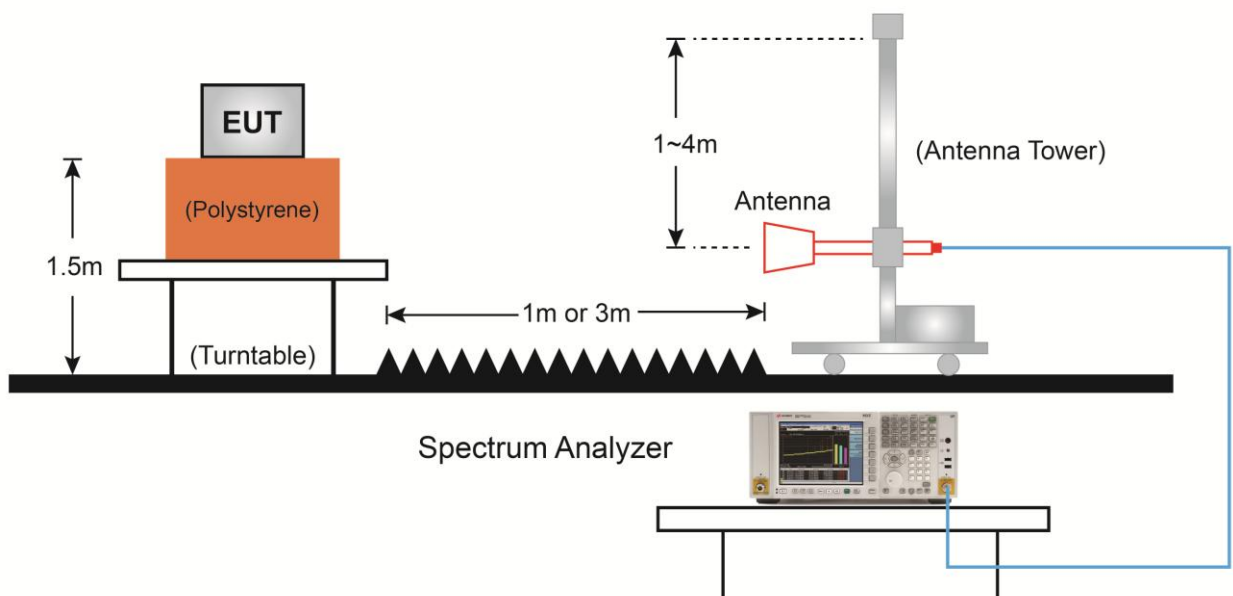

7.6.5. Test Result

Product	Wireless POS Terminal	Temperature	26°C
Test Engineer	Flay Yang	Relative Humidity	56%
Test Site	AC1	Test Date	2019/11/14
Test Mode	802.11b	Test Channel	01
Note	1. Average measurement was not performed if peak level lower than average limit. 2. Other frequency was 20dB below limit line within 1-18GHz, there is not show in the report.		

Mark	Frequency (MHz)	Reading Level (dBμV)	Factor (dB)	Measure Level (dBμV/m)	Limit (dBμV/m)	Margin (dB)	Detector	Polarization
	3881.5	36.8	2.2	39.0	74.0	-35.0	Peak	Horizontal
	4825.0	41.3	5.5	46.8	74.0	-27.2	Peak	Horizontal
*	6474.0	34.2	9.4	43.6	81.9	-38.3	Peak	Horizontal
*	7230.5	34.8	11.7	46.5	81.9	-35.4	Peak	Horizontal
	4825.0	42.9	5.5	48.4	74.0	-25.6	Peak	Vertical
	7477.0	37.2	11.9	49.1	74.0	-24.9	Peak	Vertical
*	9253.5	31.9	14.8	46.7	81.9	-35.2	Peak	Vertical
*	9950.5	33.6	16.1	49.7	81.9	-32.2	Peak	Vertical

Note 1: "*" is not in restricted band, its limit is 20dBc of the fundamental emission level (101.9dBμV/m) or 15.209 which is higher.

Note 2: Measure Level (dBμV/m) = Reading Level (dBμV) + Factor (dB)

Factor (dB) = Cable Loss (dB) + Antenna Factor (dB/m) - Pre_Amplifier Gain (dB)

Product	Wireless POS Terminal	Temperature	26°C
Test Engineer	Flay Yang	Relative Humidity	56%
Test Site	AC1	Test Date	2019/11/14
Test Mode	802.11b	Test Channel	06
Note	1. Average measurement was not performed if peak level lower than average limit. 2. Other frequency was 20dB below limit line within 1-18GHz, there is not show in the report.		

Mark	Frequency (MHz)	Reading Level (dBμV)	Factor (dB)	Measure Level (dBμV/m)	Limit (dBμV/m)	Margin (dB)	Detector	Polarization
	3932.5	36.8	2.3	39.1	74.0	-34.9	Peak	Horizontal
	4876.0	40.6	5.7	46.3	74.0	-27.7	Peak	Horizontal
*	5607.0	34.7	6.7	41.4	81.7	-40.3	Peak	Horizontal
*	7162.5	33.8	11.6	45.4	81.7	-36.3	Peak	Horizontal
	4000.5	42.0	2.5	44.5	74.0	-29.5	Peak	Vertical
	4876.0	41.5	5.7	47.2	74.0	-26.8	Peak	Vertical
*	5624.0	34.6	6.7	41.3	81.7	-40.4	Peak	Vertical
*	7205.0	34.3	11.6	45.9	81.7	-35.8	Peak	Vertical

Note 1: "*" is not in restricted band, its limit is 20dBc of the fundamental emission level (101.7dBμV/m) or 15.209 which is higher.

Note 2: Measure Level (dBμV/m) = Reading Level (dBμV) + Factor (dB)

Factor (dB) = Cable Loss (dB) + Antenna Factor (dB/m) - Pre_Amplifier Gain (dB)

Product	Wireless POS Terminal	Temperature	26°C
Test Engineer	Flay Yang	Relative Humidity	56%
Test Site	AC1	Test Date	2019/11/14
Test Mode	802.11b	Test Channel	11
Note	1. Average measurement was not performed if peak level lower than average limit. 2. Other frequency was 20dB below limit line within 1-18GHz, there is not show in the report.		

Mark	Frequency (MHz)	Reading Level (dBμV)	Factor (dB)	Measure Level (dBμV/m)	Limit (dBμV/m)	Margin (dB)	Detector	Polarization
	3856.0	36.4	2.1	38.5	74.0	-35.5	Peak	Horizontal
	4927.0	44.0	1.2	45.2	74.0	-28.8	Peak	Horizontal
*	5607.0	33.8	6.7	40.5	81.2	-40.7	Peak	Horizontal
*	6525.0	33.8	9.6	43.4	81.2	-37.8	Peak	Horizontal
	3983.5	42.0	2.5	44.5	74.0	-29.5	Peak	Vertical
	4927.0	44.5	1.2	45.7	74.0	-28.3	Peak	Vertical
*	5624.0	34.2	6.7	40.9	81.2	-40.3	Peak	Vertical
*	6550.5	34.2	9.5	43.7	81.2	-37.5	Peak	Vertical

Note 1: "*" is not in restricted band, its limit is 20dBc of the fundamental emission level (101.2dBμV/m) or 15.209 which is higher.

Note 2: Measure Level (dBμV/m) = Reading Level (dBμV) + Factor (dB)

Factor (dB) = Cable Loss (dB) + Antenna Factor (dB/m) - Pre_Amplifier Gain (dB)

Product	Wireless POS Terminal	Temperature	26°C
Test Engineer	Flay Yang	Relative Humidity	56%
Test Site	AC1	Test Date	2019/11/14
Test Mode	802.11g	Test Channel	01
Note	1. Average measurement was not performed if peak level lower than average limit. 2. Other frequency was 20dB below limit line within 1-18GHz, there is not show in the report.		

Mark	Frequency (MHz)	Reading Level (dBμV)	Factor (dB)	Measure Level (dBμV/m)	Limit (dBμV/m)	Margin (dB)	Detector	Polarization
	4136.5	36.8	3.0	39.8	74.0	-34.2	Peak	Horizontal
	4825.0	35.4	5.5	40.9	74.0	-33.1	Peak	Horizontal
*	5615.5	34.0	6.7	40.7	77.6	-36.9	Peak	Horizontal
*	7213.5	33.9	11.7	45.6	77.6	-32.0	Peak	Horizontal
	3992.0	38.1	2.5	40.6	74.0	-33.4	Peak	Vertical
	4825.0	37.5	5.5	43.0	74.0	-31.0	Peak	Vertical
*	5887.5	33.8	7.5	41.3	77.6	-36.3	Peak	Vertical
*	6559.0	33.3	9.4	42.7	77.6	-34.9	Peak	Vertical

Note 1: "*" is not in restricted band, its limit is 20dBc of the fundamental emission level (97.6dBμV/m) or 15.209 which is higher.

Note 2: Measure Level (dBμV/m) = Reading Level (dBμV) + Factor (dB)

Factor (dB) = Cable Loss (dB) + Antenna Factor (dB/m) - Pre_Amplifier Gain (dB)

Product	Wireless POS Terminal	Temperature	26°C
Test Engineer	Flay Yang	Relative Humidity	56%
Test Site	AC1	Test Date	2019/11/14
Test Mode	802.11g	Test Channel	06
Note	1. Average measurement was not performed if peak level lower than average limit. 2. Other frequency was 20dB below limit line within 1-18GHz, there is not show in the report.		

Mark	Frequency (MHz)	Reading Level (dBμV)	Factor (dB)	Measure Level (dBμV/m)	Limit (dBμV/m)	Margin (dB)	Detector	Polarization
	3992.0	36.2	2.5	38.7	74.0	-35.3	Peak	Horizontal
	4867.5	34.5	5.7	40.2	74.0	-33.8	Peak	Horizontal
*	6491.0	34.0	9.3	43.3	78.2	-34.9	Peak	Horizontal
*	7094.5	33.2	11.3	44.5	78.2	-33.7	Peak	Horizontal
	4281.0	36.0	3.5	39.5	74.0	-34.5	Peak	Vertical
	4876.0	36.8	5.7	42.5	74.0	-31.5	Peak	Vertical
*	6499.5	33.9	9.4	43.3	78.2	-34.9	Peak	Vertical
*	7171.0	33.4	11.7	45.1	78.2	-33.1	Peak	Vertical

Note 1: "*" is not in restricted band, its limit is 20dBc of the fundamental emission level (98.2dBμV/m) or 15.209 which is higher.

Note 2: Measure Level (dBμV/m) = Reading Level (dBμV) + Factor (dB)

Factor (dB) = Cable Loss (dB) + Antenna Factor (dB/m) - Pre_Amplifier Gain (dB)

Product	Wireless POS Terminal	Temperature	26°C
Test Engineer	Flay Yang	Relative Humidity	56%
Test Site	AC1	Test Date	2019/11/14
Test Mode	802.11g	Test Channel	11
Note	1. Average measurement was not performed if peak level lower than average limit. 2. Other frequency was 20dB below limit line within 1-18GHz, there is not show in the report.		

Mark	Frequency (MHz)	Reading Level (dBμV)	Factor (dB)	Measure Level (dBμV/m)	Limit (dBμV/m)	Margin (dB)	Detector	Polarization
	4153.5	35.3	3.1	38.4	74.0	-35.6	Peak	Horizontal
	4833.5	35.2	5.5	40.7	74.0	-33.3	Peak	Horizontal
*	6542.0	33.5	9.6	43.1	78.5	-35.4	Peak	Horizontal
*	7103.0	33.1	11.4	44.5	78.5	-34.0	Peak	Horizontal
	4612.5	36.4	4.7	41.1	74.0	-32.9	Peak	Vertical
	4918.5	36.0	5.8	41.8	74.0	-32.2	Peak	Vertical
*	5998.0	34.4	7.5	41.9	78.5	-36.6	Peak	Vertical
*	6627.0	33.8	9.5	43.3	78.5	-35.2	Peak	Vertical

Note 1: "*" is not in restricted band, its limit is 20dBc of the fundamental emission level (98.5dBμV/m) or 15.209 which is higher.

Note 2: Measure Level (dBμV/m) = Reading Level (dBμV) + Factor (dB)

Factor (dB) = Cable Loss (dB) + Antenna Factor (dB/m) - Pre_Amplifier Gain (dB)

Product	Wireless POS Terminal	Temperature	26°C
Test Engineer	Flay Yang	Relative Humidity	56%
Test Site	AC1	Test Date	2019/11/14
Test Mode	802.11n-HT20	Test Channel	01
Note	1. Average measurement was not performed if peak level lower than average limit. 2. Other frequency was 20dB below limit line within 1-18GHz, there is not show in the report.		

Mark	Frequency (MHz)	Reading Level (dBμV)	Factor (dB)	Measure Level (dBμV/m)	Limit (dBμV/m)	Margin (dB)	Detector	Polarization
	4000.5	35.3	2.5	37.8	74.0	-36.2	Peak	Horizontal
	4646.5	37.9	2.0	39.9	74.0	-34.1	Peak	Horizontal
*	5598.5	34.4	6.7	41.1	79.5	-38.4	Peak	Horizontal
*	6499.5	33.4	9.4	42.8	79.5	-36.7	Peak	Horizontal
	3992.0	36.8	2.5	39.3	74.0	-34.7	Peak	Vertical
	4825.0	41.1	1.9	43.0	74.0	-31.0	Peak	Vertical
*	5998.0	34.8	7.5	42.3	79.5	-37.2	Peak	Vertical
*	6550.5	32.9	9.5	42.4	79.5	-37.1	Peak	Vertical

Note 1: "*" is not in restricted band, its limit is 20dBc of the fundamental emission level (99.5dBμV/m) or 15.209 which is higher.

Note 2: Measure Level (dBμV/m) = Reading Level (dBμV) + Factor (dB)

Factor (dB) = Cable Loss (dB) + Antenna Factor (dB/m) - Pre_Amplifier Gain (dB)

Product	Wireless POS Terminal	Temperature	26°C
Test Engineer	Flay Yang	Relative Humidity	56%
Test Site	AC1	Test Date	2019/11/14
Test Mode	802.11n-HT20	Test Channel	06
Note	1. Average measurement was not performed if peak level lower than average limit. 2. Other frequency was 20dB below limit line within 1-18GHz, there is not show in the report.		

Mark	Frequency (MHz)	Reading Level (dBμV)	Factor (dB)	Measure Level (dBμV/m)	Limit (dBμV/m)	Margin (dB)	Detector	Polarization
	4604.0	36.1	4.7	40.8	74.0	-33.2	Peak	Horizontal
	4867.5	38.9	1.6	40.5	74.0	-33.5	Peak	Horizontal
*	6814.0	34.3	9.7	44.0	78.7	-34.7	Peak	Horizontal
*	7205.0	33.8	11.6	45.4	78.7	-33.3	Peak	Horizontal
	3992.0	38.3	2.5	40.8	74.0	-33.2	Peak	Vertical
	4876.0	37.8	5.7	43.5	74.0	-30.5	Peak	Vertical
*	6159.5	33.7	7.9	41.6	78.7	-37.1	Peak	Vertical
*	6542.0	33.8	9.6	43.4	78.7	-35.3	Peak	Vertical

Note 1: "*" is not in restricted band, its limit is 20dBc of the fundamental emission level (98.7dBμV/m) or 15.209 which is higher.

Note 2: Measure Level (dBμV/m) = Reading Level (dBμV) + Factor (dB)

Factor (dB) = Cable Loss (dB) + Antenna Factor (dB/m) - Pre_Amplifier Gain (dB)

Product	Wireless POS Terminal	Temperature	26°C
Test Engineer	Flay Yang	Relative Humidity	56%
Test Site	AC1	Test Date	2019/11/14
Test Mode	802.11n-HT20	Test Channel	11
Note	1. Average measurement was not performed if peak level lower than average limit. 2. Other frequency was 20dB below limit line within 1-18GHz, there is not show in the report.		

Mark	Frequency (MHz)	Reading Level (dBμV)	Factor (dB)	Measure Level (dBμV/m)	Limit (dBμV/m)	Margin (dB)	Detector	Polarization
	4281.0	34.7	3.5	38.2	74.0	-35.8	Peak	Horizontal
	5105.5	34.3	6.4	40.7	74.0	-33.3	Peak	Horizontal
*	6100.0	34.4	7.6	42.0	77.4	-35.4	Peak	Horizontal
*	6550.5	33.7	9.5	43.2	77.4	-34.2	Peak	Horizontal
	4298.0	35.7	3.6	39.3	74.0	-34.7	Peak	Vertical
	4927.0	35.1	5.8	40.9	74.0	-33.1	Peak	Vertical
*	6482.5	34.1	9.4	43.5	77.4	-33.9	Peak	Vertical
*	8726.5	34.3	13.2	47.5	77.4	-29.9	Peak	Vertical

Note 1: "*" is not in restricted band, its limit is 20dBc of the fundamental emission level (97.4dBμV/m) or 15.209 which is higher.

Note 2: Measure Level (dBμV/m) = Reading Level (dBμV) + Factor (dB)

Factor (dB) = Cable Loss (dB) + Antenna Factor (dB/m) - Pre_Amplifier Gain (dB)

The Worst Case of Radiated Emission below 1GHz:

Site: AC1	Time: 2019/11/26 - 13:05
Limit: FCC_Part15.209_RE(3m)	Engineer: Flay Yang
Probe: AC1_VULB 9168 _20-2000MHz	Polarity: Horizontal
EUT: Wireless POS Terminal	Power: By Battery
Test Mode: Transmit by 802.11b at channel 2437MHz	

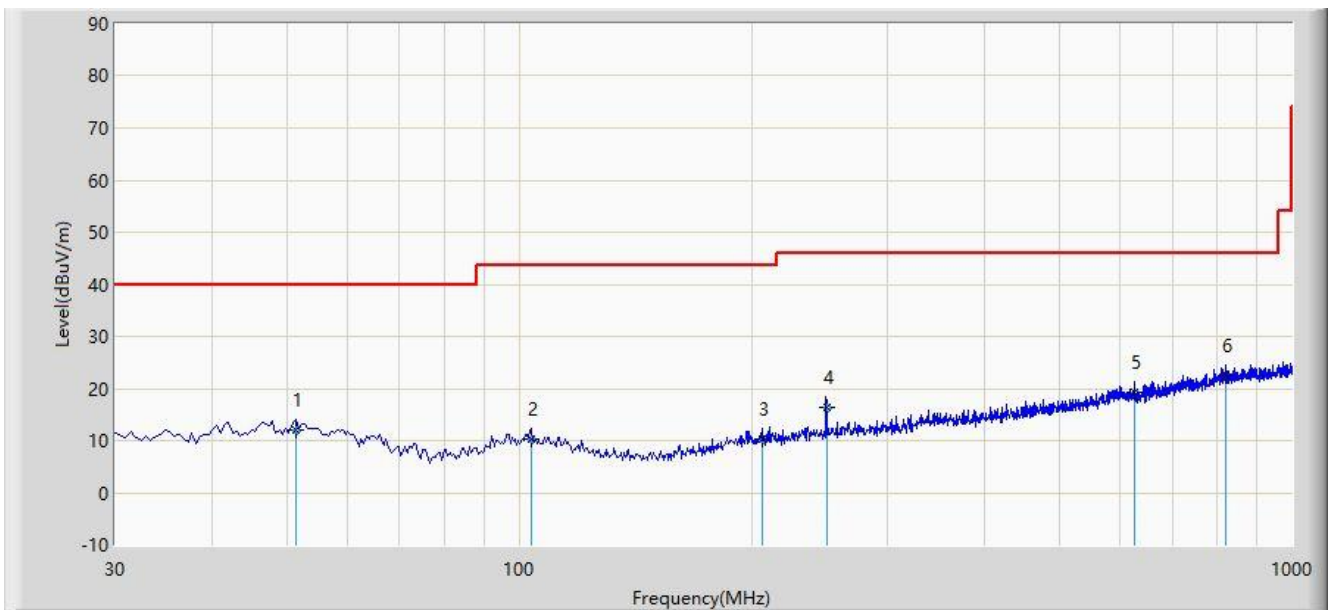

No	Flag	Mark	Frequency (MHz)	Measure Level (dBuV/m)	Reading Level (dBuV)	Margin (dB)	Limit (dBuV/m)	Factor (dB)	Type
1			51.340	11.891	-2.150	-28.109	40.000	14.041	QP
2			103.720	10.197	-1.209	-33.303	43.500	11.406	QP
3			206.055	10.258	-1.021	-33.242	43.500	11.279	QP
4			250.000	16.319	3.350	-29.681	46.000	12.969	QP
5			626.087	19.281	-1.822	-26.719	46.000	21.102	QP
6		*	821.520	22.570	-0.890	-23.430	46.000	23.459	QP

Note 1: Measure Level (dB μ V/m) = Reading Level (dB μ V) + Factor (dB)

Factor (dB) = Cable Loss (dB) + Antenna Factor (dB/m)

Note 2: The test trace is same as the ambient noise and the amplitude of the emissions are attenuated more than 20dB below the permissible (the test frequency range: 9kHz ~ 30MHz, 18GHz ~ 25GHz), therefore no data appear in the report.

Site: AC1	Time: 2019/11/26 - 13:12
Limit: FCC_Part15.209_RE(3m)	Engineer: Flay Yang
Probe: AC1_VULB 9168 _20-2000MHz	Polarity: Vertical
EUT: Wireless POS Terminal	Power: By Battery
Test Mode: Transmit by 802.11b at channel 2437MHz	

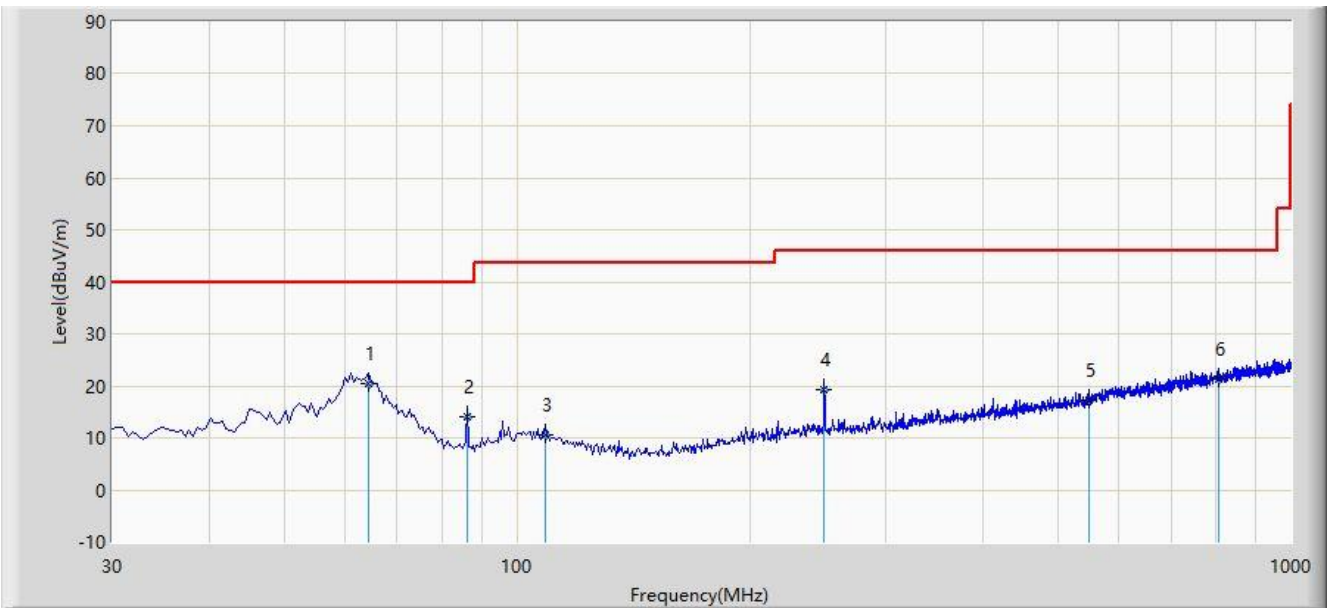

No	Flag	Mark	Frequency (MHz)	Measure Level (dBuV/m)	Reading Level (dBuV)	Margin (dB)	Limit (dBuV/m)	Factor (dB)	Type
1		*	64.435	20.354	7.773	-19.646	40.000	12.581	QP
2			86.260	13.985	3.793	-26.015	40.000	10.193	QP
3			109.055	10.613	-1.340	-32.887	43.500	11.954	QP
4			249.700	19.388	6.420	-26.612	46.000	12.967	QP
5			548.950	17.375	-2.161	-28.625	46.000	19.536	QP
6			807.940	21.344	-2.010	-24.656	46.000	23.354	QP

Note 1: Measure Level (dB μ V/m) = Reading Level (dB μ V) + Factor (dB)

Factor (dB) = Cable Loss (dB) + Antenna Factor (dB/m)

Note 2: The test trace is same as the ambient noise and the amplitude of the emissions are attenuated more than 20dB below the permissible (the test frequency range: 9kHz ~ 30MHz, 18GHz ~ 25GHz), therefore no data appear in the report.

7.7. Radiated Restricted Band Edge Measurement

7.7.1. Test Limit

For 15.205 requirement:

Radiated emissions which fall in the restricted bands, as defined in Section 15.205(a) of FCC part 15, must also comply with the radiated emission limits specified in Section 15.209(a).

Frequency (MHz)	Frequency (MHz)	Frequency (MHz)	Frequency (GHz)
0.090 - 0.110	16.42 - 16.423	399.9 - 410	4.5 - 5.15
¹ 0.495 - 0.505	16.69475 - 16.69525	608 - 614	5.35 - 5.46
2.1735 - 2.1905	16.80425 - 16.80475	960 - 1240	7.25 - 7.75
4.125 - 4.128	25.5 - 25.67	1300 - 1427	8.025 - 8.5
4.17725 - 4.17775	37.5 - 38.25	1435 - 1626.5	9.0 - 9.2
4.20725 - 4.20775	73 - 74.6	1645.5 - 1646.5	9.3 - 9.5
6.215 - 6.218	74.8 - 75.2	1660 - 1710	10.6 - 12.7
6.26775 - 6.26825	108 - 121.94	1718.8 - 1722.2	13.25 - 13.4
6.31175 - 6.31225	123 - 138	2200 - 2300	14.47 - 14.5
8.291 - 8.294	149.9 - 150.05	2310 - 2390	15.35 - 16.2
8.362 - 8.366	156.52475 - 156.52525	2483.5 - 2500	17.7 - 21.4
8.37625 - 8.38675	156.7 - 156.9	2690 - 2900	22.01 - 23.12
8.41425 - 8.41475	162.0125 - 167.17	3260 - 3267	23.6 - 24.0
12.29 - 12.293	167.72 - 173.2	3332 - 3339	31.2 - 31.8
12.51975 - 12.52025	240 - 285	3345.8 - 3358	36.43 - 36.5
12.57675 - 12.57725	322 - 335.4	3600 - 4400	(²)
13.36 - 13.41	--	--	--

All out of band emissions appearing in a restricted band as specified in Section 15.205 of the Title 47CFR must not exceed the limits shown in Table per Section 15.209.

FCC Part 15 Subpart C Paragraph 15.209 Limits		
Frequency [MHz]	Field Strength [uV/m]	Measured Distance [Meters]
0.009 - 0.490	2400/F (kHz)	300
0.490 - 1.705	24000/F (kHz)	30
1.705 - 30	30	30
30 - 88	100	3
88 - 216	150	3
216 - 960	200	3
Above 960	500	3

7.7.2. Test Procedure Used

ANSI C63.10 Section 6.3 (General Requirements)

ANSI C63.10 Section 6.6 (Standard test method above 1GHz)

7.7.3. Test Setting

Peak Field Strength Measurements

1. Analyzer center frequency was set to the frequency of the radiated spurious emission of interest
2. RBW = 1MHz
3. VBW = 3MHz
4. Detector = peak
5. Sweep time = auto couple
6. Trace mode = max hold
7. Trace was allowed to stabilize