

---

## Statement

In order to use the terminal safely and correctly, please read this operation guide carefully before use and deploy the terminal. If you want to know all of the particular configurations clearly about this terminal, please refer to the related contracts and agreements of the terminal, or you can consult with the agent.

The pictures and photos in this guide are for reference only. If any of the pictures and photos do not match to the terminal, please prevail in kind.

Many of the network services in this guide are provided by the 3<sup>rd</sup> party network service providers. Therefore, whether or not be able to use these network services are mainly depending on the 3<sup>rd</sup> party network service providers.

The company reserves all the rights to this guild. In other words, no individuals or parties are allowed to copy, excerpt, backup, or change any of the contents in this guild unless the company says so.

## Package Contents

Item	Amount
V39 hand-hold mini POS terminal	1
Lithium battery	1
Power adapter	1
USB cable	1
Quick operation guide	1
Certificate of qualification	1
Warranty card	1
Desiccant	1

---

## Security

- The installation and use of this product must strictly follow the instructions in this guide.
- Unauthorized disassembly of this device will result in the destruction of the built-in security key, resulting in disabling to use.
- Donot drop, scratch, twist, hit, vibrate the machine or place heavy objects on the top of it.
- Donot use sharp objects to touch or collide with the unit, especially the display screen. Disobey to do so may cause the display screen to be damaged or not displayed properly.
- Wipe the screen with a soft, slightly moist, and non-maturing fabric to remove any traces of oil left by fingers. Do not use corrosive cleaners.
- This product uses the standard power adapter. Donot use non-standard power adapters, otherwise they may cause the equipment not being able to function as usual or cause serious damage.
- The power supply of this product must come from the original standard lithium battery. Please do not use any other non-standard batteries, otherwise they may cause the device not being able to function as usual or cause serious damage.
- This product is an electrical product. Donot spill any liquid material, otherwise it may cause the risks of internal short-circuit and seriousdamage to the device.
- Donot insert any metal foreign matters into any interface or port of the device.
- Donot use the device in direct sunlight, high temperature, humid, dusty, or strong magnetic field environment.
- Finding the device damaged or broken down, please stop using the device immediately and contact the relevant after-sales service department. Unauthorized repair or maintenance is strictly forbidden.

# Product Description

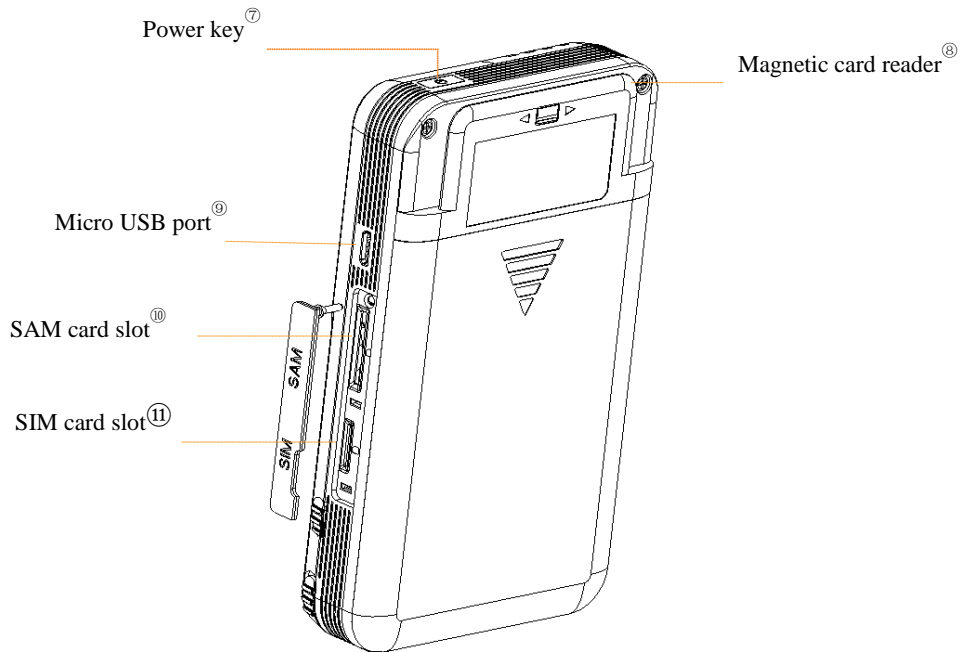
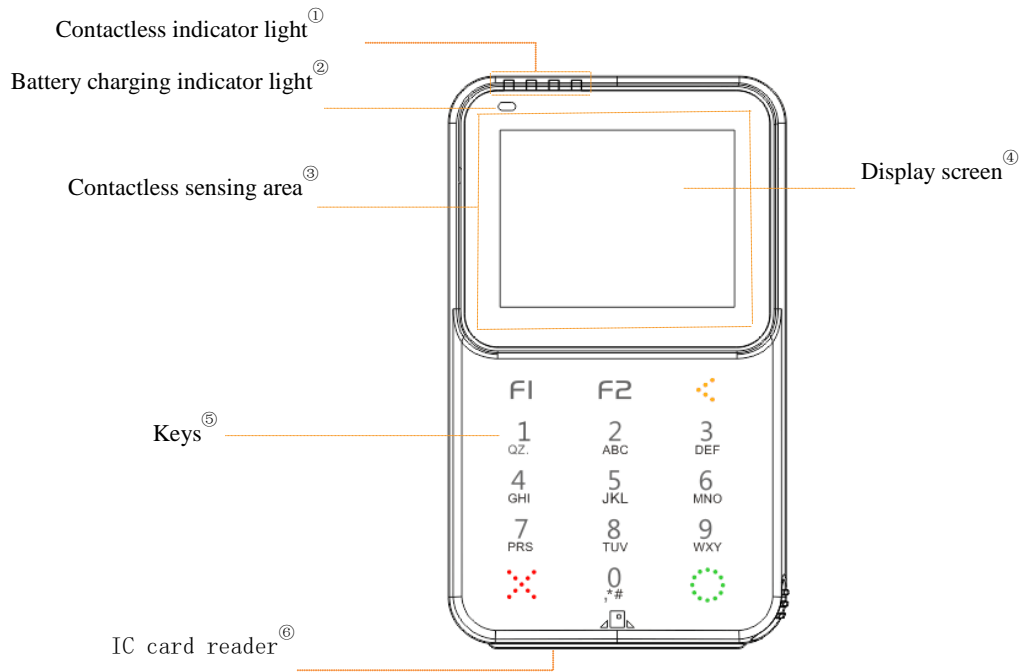

Items	Features
Contactless indicator light <sup>①</sup>	The 4-color indicator provides a status indication for the operation that may vary depending on the application configuration.
Battery charging indicator light <sup>②</sup>	The 2-color battery charging indicator light.
Contactless sensing area <sup>③</sup>	Induction area for contactless IC card reading and writing.
Display screen <sup>④</sup>	Displays operation, transaction information and allows E-Signature.
Keys <sup>⑤</sup>	Input amount of money and password, confirm or cancel transactions.
IC card reader <sup>⑥</sup>	IC card reading area.
Power key <sup>⑦</sup>	Control of turning on or off.
Magnetic card reader <sup>⑧</sup>	Magnetic stripe card reader, support bi-direction swiping.
Micro USB port <sup>⑨</sup>	Used for connecting external PC or other terminals, allows to do data transmission and battery charging.
SAM card slot <sup>⑩</sup>	SAM card slot
SIM card slot <sup>⑪</sup>	SIM card slot

## Quick installation

Take out the POS terminal, the battery, the power adapter, and other necessary parts from the packing box, then follow the steps below for a quick installation.

1 Install and remove the lithium battery:

Install the battery:

- ① Open the battery cover;
- ② Insert the plug side of the battery into the battery socket.
- ③ Put the battery into the battery container
- ④ Close the battery cover

---

Remove the battery:

- ① Open the battery cover after power-off
- ② Slightly pull up the battery for a certain height to remove the battery

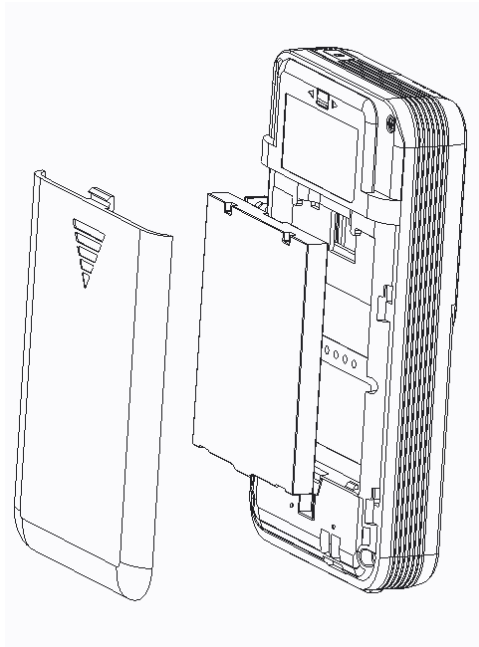

2 Install the SIM/ SAM (PSAM) card:

- ① Open the SIM/SAM card cover on the right side of the terminal;
- ② Follow the silkscreen indication and place each of the needed SIM/ SAM card separately into the right slot following the direction as the picture showed.

[Cautions]

SIM/ SAM card can not paste stickers, tags, or other materials that may change the thickness of the card in order to prevent non-smooth installation or disassembly.

Address: 3/F, No.2 Building, Aerospace Information Park, No.18 A, Xingshikou Road, Haidian District, Beijing

Zip code: 100195

Email: [into@vanstone.com.cn](mailto:into@vanstone.com.cn)

Manufacture name: Vanstone Electronic( Huizhou) Co.,Ltd

Manufacture Address: 4/F, No.12 Building, Aerospace Science and Technology industrial Park, No.51,Zhongkai Road, Huizhou

[Http://www.vanstone.com.cn](http://www.vanstone.com.cn)

## Warranty Card

Thank you for purchasing our products!

The warranty period of this product is subject to the warranty period of the contract, from the date of purchase (based on the date showed on the receipt).

After the warranty expiration, we still provide the life-long maintenance. We usually require a payment once for a certain maintenance and spare part costs from our customers. Then we will provide the life-long maintenance to our customers with extraordinary quality.

When you need to require a repair or a maintenance service, please fill out the "product failure report form" and send the form along with the warranty card back to us.

The warranty card is a necessary certification of the Company's warranty service. Please keep it safe and will not be reissued.

User name	
Contact person	
User phone	
Address	
Zip code	
Serial number	
Date of purchase	
Fault description:	

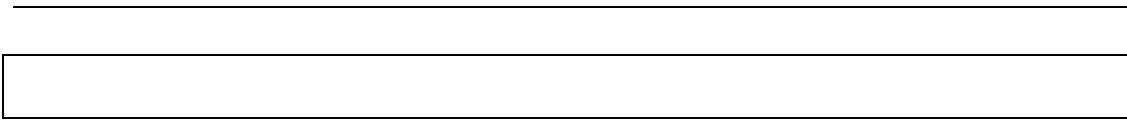

Official seal:

Please cut along with dotted line

---

### 3 Communication connection

When using GPRS to communicate, please insert the SIM card into the SIM card slot located on the right side of the terminal. When using Bluetooth to communicate, please turn on the Bluetooth module on the smart mobile terminal such as a smartphone or tablet, and search for the Micropayment POS terminal around to match.

## Usage and Operation

#### Power on / Power off:

Press and hold the on/off key for a few seconds, the device should be turned on or off.

#### Magnetic stripe card operation:

When operating a transaction with a magnetic stripe card, please set the track of the magnetic stripe on the card toward the device and swipe smoothly along with the track of the magnetic reader on the device.

#### Contact IC card operation:

IC card reader is located on the bottom of the device. When operating a transaction with contact IC card, please hold the side of the IC card that is without the chip, and flat insert the card, the chip side should face up, into the card reader. During the transaction, the IC card should be kept in the card slot.

#### Contactless IC card operation:

The IC card should be close to the center of the contactless sensing area, and stay for approximately 1 second. Do not remove the IC card until the transaction is successfully accepted.

## Troubles and Troubleshooting

Troubles	Troubleshooting
----------	-----------------



Fail to turn on the device when pressing the power key	<ol style="list-style-type: none"> <li>1. The battery is exhausted and cannot be recharged. Please change the battery.</li> <li>2. The battery is low. Please recharge the battery.</li> </ol>
Device is frozen or has serious mistakes	If the device is frozen or suspended, it may need to be shutdown or restarted to re-motivate functions.
Cannot find another Bluetooth device	<ol style="list-style-type: none"> <li>1. Please ensure that Bluetooth and wireless functions have been turned on.</li> <li>2. Please ensure that the device to connect has turned on its Bluetooth and wireless functions.</li> <li>3. Please ensure that the POS terminal and the device to connect are within the maximum Bluetooth range of 10 meters.</li> </ol>

If the problem remains the same, please contact customer service.

- 
- If the power adapter plug or power cord is damaged, please do not use them in case of electric shock or fire.
  - Please do not touch power cord with wet hand or pull out the power adapter like pulling power cable.
  - Please do not touch the device and power adapter with wet hand in case of short circuit, malfunction, or electric shock.
  - Please stop using the power adapter and contact sales representatives for exchanging if the power adapter is caught in the rain, getting wet, or affected with damp seriously.
  - The power adapter has to meet all of the requirements from the “2.5 Restricted power supply” in <<GB4943.1 Safety of information technology equipment>>.
  - If the device has to connect USB ports, please ensure that the USB ports has USB-IF identification, and its performance is qualified with the USB-IF requirements.

## Cautions for use

### Operating environment

- Do not use the device in thunderstorms which can cause the device malfunction or electric shock.
- Keep the device away from rain, moisture or liquids containing acidic substances that can corrode electronic circuit boards.
- Do not store or use the device in a dusty or dirty place.
- Do not store the device in a high temperature place. High temperature will shorten the life of the electronic device.
- Do not place the device in a super-cooling place. When the temperature of the device rises, moisture may be formed inside the equipment, which may damage the circuit board.
- Do not try to disassemble the device. Non-professional manipulating will damage the device.
- Do not use a pen, pencil, or other sharp objects to touch the screen surface to

---

avoid scratching the screen.

- Do not drop, strike, or seriously crash the device. Rough behaviors may damage the device and may cause malfunction.

#### Accessories requirements

- Please use only the battery, power adapter and other accessories that are authorized by product manufacturer and match to the device. Using unauthorized and incompatible accessories may cause fire, explosion, or other dangers.
- If using unauthorized accessories, the user may disobey the warranty rules and countries' related regulations and may lead to accidents. If users want to acquire authorized accessories, please contact your sales agents or distributors.

#### Power adapter safety

- When the device is charged, the power socket should be installed near the device and should be easy to touch. The charging area of the equipment must be clean without debris, flammable or chemical substance.
- When charging is over or uncharged, please cut off the connection between the power adapter and the device, and please unplug the charger from the power socket.
- Please do not drop or crash the power adapter. Once the shell of the adapter is damaged, please contact the agent or distributor who sell the equipment to exchange the power adapter.

#### Battery safety

- Please do not use short circuit batteries, or contact the battery terminals with metal or other conductive objects.
- Please do not disassemble, squeeze, twist, or cut the battery.
- Please do not insert external matter into the battery, contact the battery with water or other liquid, and expose the battery to open flame, explosion source, or other risk sources.

- 
- Please do not place or store the battery in an over-temperature environment.
  - Please do not throw the battery into water.
  - Do not touch the skin or eyes if a battery leak occurs. If you are stained, rinse the contact area with plenty of water and seek medical attention immediately.
  - Please do not use broken or damaged battery.
  - When the standby duration of the device is obviously shorter than usual, please exchange a new battery.

### Cautions

There will be a danger of explosion using the wrong model of battery

The battery must be disposed in accordance with the instructions

FCC Caution:

Any Changes or modifications not expressly approved by the party responsible for compliance could void the user's authority to operate the equipment.

This device complies with part 15 of the FCC Rules. Operation is subject to the following two conditions: (1) This device may not cause harmful interference, and (2) this device must accept any interference received, including interference that may cause undesired operation.

IMPORTANT NOTE:

Note: This equipment has been tested and found to comply with the limits for a Class B digital device, pursuant to part 15 of the FCC Rules. These limits are designed to provide reasonable protection against harmful interference in a residential installation. This equipment generates, uses and can radiate radio frequency energy and, if not installed and used in accordance with the instructions, may cause harmful interference to radio communications. However,

---

there is no guarantee that interference will not occur in a particular installation. If this equipment does cause harmful interference to radio or television reception, which can be determined by turning the equipment off and on, the user is encouraged to try to correct the interference by one or more of the following measures:

—Reorient or relocate the receiving antenna.

—Increase the separation between the equipment and receiver.

—Connect the equipment into an outlet on a circuit different from that to which the receiver is connected.

—Consult the dealer or an experienced radio/TV technician for help.

FCC Radiation Exposure Statement:

The device has been tested and comply with FCC SAR limits.

Quick Start Guide

V39 POS terminal



The pictures and photos in this guide are for reference only, please prevail in kind.