

FCC PART 15, CLASS B TEST REPORT

For

Kasda Digital Technology Co., Ltd.

B-31 Building, Tanglang Industry Zone, XiLi Nanshan, Shenzhen, China

FCC ID: OWI-KW5811

Report Type: Original Report	Product Type: Wireless ADSL Router
Test Engineer: <u>William Li</u>	<i>William Li</i>
Report Number: <u>RSZ140812004-00A</u>	
Report Date: <u>2014-09-25</u>	
Reviewed By: <u>Jimmy Xiao</u> RF Engineer	<i>Jimmy Xiao</i>
Prepared By: Bay Area Compliance Laboratories Corp. (Shenzhen) 6/F, the 3rd Phase of WanLi Industrial Building ShiHua Road, FuTian Free Trade Zone Shenzhen, Guangdong, China Tel: +86-755-33320018 Fax: +86-755-33320008 www.baclcorp.com.cn	

Note: This test report is prepared for the customer shown above and for the device described herein. It may not be duplicated or used in part without prior written consent from Bay Area Compliance Laboratories Corp.

TABLE OF CONTENTS

GENERAL INFORMATION.....	3
PRODUCT DESCRIPTION FOR EQUIPMENT UNDER TEST (EUT).....	3
OBJECTIVE.....	3
RELATED SUBMITTAL(S)/GRANT(S).....	3
TEST FACILITY.....	3
SYSTEM TEST CONFIGURATION.....	4
DESCRIPTION OF TEST CONFIGURATION.....	4
EUT EXERCISE SOFTWARE.....	4
SPECIAL ACCESSORIES.....	4
EQUIPMENT MODIFICATIONS.....	4
SUPPORT EQUIPMENT LIST AND DETAILS.....	4
EXTERNAL I/O CABLE.....	4
BLOCK DIAGRAM OF TEST SETUP.....	5
SUMMARY OF TEST RESULTS.....	6
FCC §15.107 – AC LINE CONDUCTED EMISSIONS.....	7
APPLICABLE STANDARD.....	7
MEASUREMENT UNCERTAINTY.....	7
EUT SETUP.....	7
EMI TEST RECEIVER SETUP.....	8
TEST PROCEDURE.....	8
TEST EQUIPMENT LIST AND DETAILS.....	8
CORRECTED FACTOR & MARGIN CALCULATION.....	8
TEST RESULTS SUMMARY.....	9
TEST DATA.....	9
FCC §15.109 - RADIATED SPURIOUS EMISSIONS.....	12
APPLICABLE STANDARD.....	12
MEASUREMENT UNCERTAINTY.....	12
EUT SETUP.....	12
EMI TEST RECEIVER SETUP.....	13
TEST PROCEDURE.....	13
TEST EQUIPMENT LIST AND DETAILS.....	14
CORRECTED AMPLITUDE & MARGIN CALCULATION.....	14
TEST RESULTS SUMMARY.....	14
TEST DATA.....	15
PRODUCT SIMILARITY DECLARATION LETTER.....	16

GENERAL INFORMATION

Product Description for Equipment under Test (EUT)

The *Kasda Digital Technology Co., Ltd.*'s product, model number: *KW5811 (FCC ID: OWI-KW5811)* or the "EUT" in this report was a *Wireless ADSL Router*, which was measured approximately: 13 cm (L) x 10.5 cm (W) x 3.8 cm (H), rated with input voltage: DC 12V from adapter. The highest operating frequency is 200MHz.

Adapter information:

Model: DSA-12PFA-09 FUS 120100

Input: 100-240V~50/60 Hz, 0.5A

Output: DC 12V, 1.0A

Note: The serial models KW5811, CXB-1511 and SN-1511 share the same schematics, they are different in model names, the details were explained in the attached product similarity declaration letter provided and guaranteed by applicant. Model KW5811 was selected for testing.

**All measurement and test data in this report was gathered from production sample serial number: KW5811000068 (Assigned by the applicant). The EUT supplied by the applicant was received on 2014-08-12.*

Objective

This test report is prepared on behalf of *Kasda Digital Technology Co., Ltd.* in accordance with Part 2-Subpart J, Part 15-Subparts A and B of the Federal Communication Commissions rules.

The objective of the manufacturer is to determine the compliance of the EUT with FCC Part 15 B.

Related Submittal(s)/Grant(s)

FCC Part 15.247 DTS, submissions with ID: OWI-KW5811

Test Facility

The test site used by Bay Area Compliance Laboratories Corp. (Shenzhen) to collect test data is located on the 6/F, the 3rd Phase of WanLi Industrial Building, ShiHua Road, FuTian Free Trade Zone Shenzhen, Guangdong, China.

Test site at Bay Area Compliance Laboratories Corp. (Shenzhen) has been fully described in reports submitted to the Federal Communication Commission (FCC). The details of these reports have been found to be in compliance with the requirements of Section 2.948 of the FCC Rules on December 06, 2010. The facility also complies with the radiated and AC line conducted test site criteria set forth in ANSI C63.4-2009.

The Federal Communications Commission has the reports on file and is listed under FCC Registration No.: 382179. The test site has been approved by the FCC for public use and is listed in the FCC Public Access Link (PAL) database.

SYSTEM TEST CONFIGURATION

Description of Test Configuration

The system was configured for testing in a manufacturer testing fashion.

EUT Exercise Software

Open page (<http://192.168.1.1>) and disable wireless function

Special Accessories

No special accessory.

Equipment Modifications

No modification was made to the EUT tested.

Support Equipment List and Details

Manufacturer	Description	Model	Serial Number
DELL	PC	VOSTRO 220S	127BP2X
DELL	LCD Monitor	E178WFPC	CN-OWY564-64180-7C4-2SQH
DELL	Keyboard	L100	CNORH656658907BL05DC
DELL	Mouse	MOC5UO	G1900NKD
SAST	Modem	AEM-2100	0293
Huawei	DSLAM	MA5105	N/A

External I/O Cable

Cable Description	Length (m)	From/Port	To
Shielding Detachable USB Cable	1.5	Host PC	Mouse
Shielding Detachable Serial Cable	1.2	Host PC	Modem
Shielding Detachable K/B Cable	1.5	Host PC	Keyboard
Shielding Detachable VGA Cable	1.5	Host PC	LCD Monitor
Un-shielding Detachable DC Cable	1.5	Modem	Modem Adapter
Un-shielding Detachable Modem Cable	1.5	Modem	Host PC
Un-shielding Undetachable DC Power Cable	1.2	EUT	Adapter
Un-shielding Detachable RJ45 Cable	1.5	EUT	Host PC
Unshielded Detachable RJ11 Cable	2.0	EUT	DSLAM

Block Diagram of Test Setup

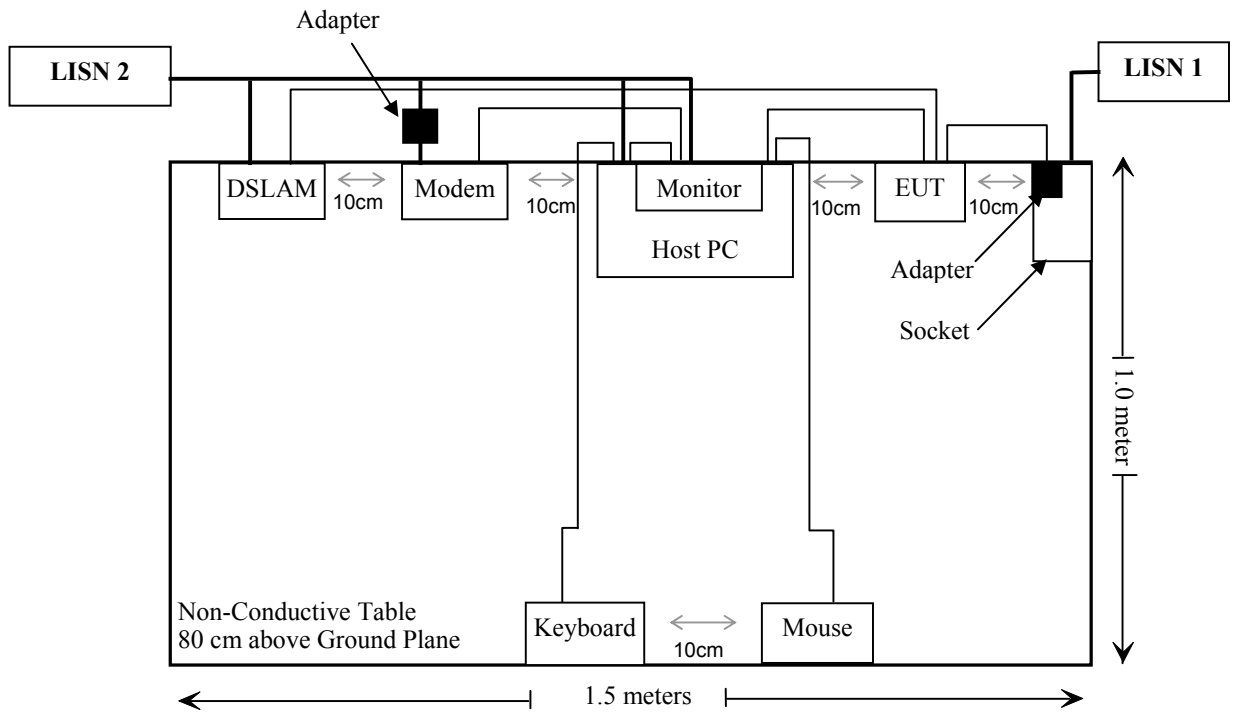

SUMMARY OF TEST RESULTS

FCC Rules	Description of Test	Results
§15.107	AC Line Conducted Emissions	Compliance
§15.109	Radiated Spurious Emissions	Compliance

FCC §15.107 – AC LINE CONDUCTED EMISSIONS

Applicable Standard

According to FCC §15.107

Measurement Uncertainty

Input quantities to be considered for conducted disturbance measurements maybe receiver reading, attenuation of the connection between LISN and receiver, LISN voltage division factor, LISN VDF frequency interpolation and receiver related input quantities, etc.

Based on CISPR 16-4-2:2011, the expanded combined standard uncertainty of conducted disturbance test at Bay Area Compliance Laboratories Corp. (Shenzhen) is shown as below. And the uncertainty will not be taken into consideration for the test data recorded in the report

Port	Expanded Measurement uncertainty
AC Mains	3.26 dB (k=2, 95% level of confidence)
CAT 3	3.70 dB (k=2, 95% level of confidence)
CAT 5	3.86 dB (k=2, 95% level of confidence)
CAT 6	4.64 dB (k=2, 95% level of confidence)

EUT Setup

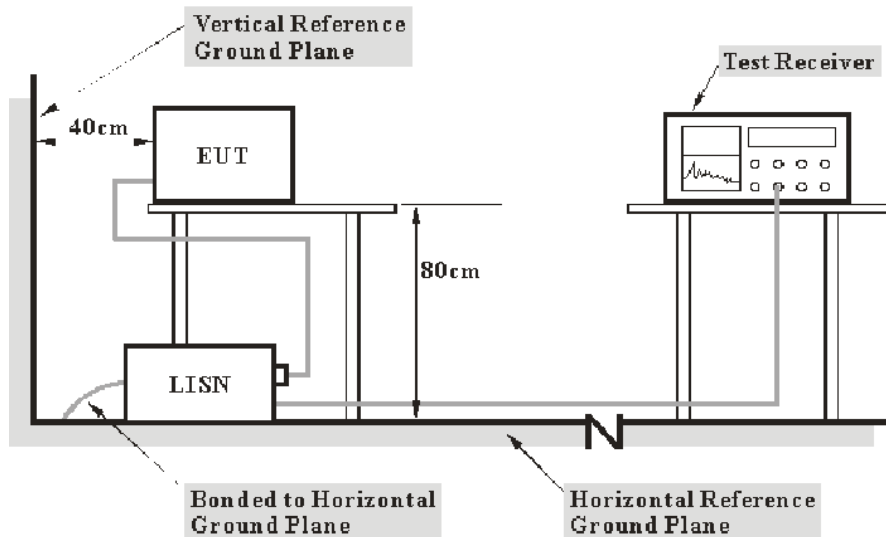

- Note: 1. Support units were connected to second LISN.
 2. Both of LISNs (AMN) 80 cm from EUT and at the least 80 cm from other units and other metal planes support units.

The measurement procedure of EUT setup is according with per ANSI C63.4-2009. The related limit was specified in FCC Part 15.107 Class B.

The spacing between the peripherals was 10 cm.

The adapter was connected to a 120 VAC/60 Hz power source.

EMI Test Receiver Setup

The EMI test receiver was set to investigate the spectrum from 150 kHz to 30 MHz.

During the conducted emission test, the EMI test receiver was set with the following configurations:

Frequency Range	IF B/W
150 kHz – 30 MHz	9 kHz

Test Procedure

During the conducted emission test, the adapter was connected to the outlet of the first LISN, and the other relevant equipments were connected to the outlet of the second LISN.

Maximizing procedure was performed on the six (6) highest emissions of the EUT.

All final data was recorded in the Quasi-peak and average detection mode.

Test Equipment List and Details

Manufacturer	Description	Model	Serial Number	Calibration Date	Calibration Due Date
Rohde & Schwarz	EMI Test Receiver	ESCS30	100176	2014-06-03	2015-06-03
Rohde & Schwarz	LISN	ESH2-Z5	892107/021	2014-06-09	2015-06-09
Rohde & Schwarz	LISN	ENV216	3560.6650.12-101613-Yb	2014-06-09	2015-06-09
Rohde & Schwarz	Transient Limiter	ESH3Z2	DE25985	2014-05-14	2015-05-14
Rohde & Schwarz	CE Test software	EMC 32	V8.53	--	--

* **Statement of Traceability:** Bay Area Compliance Laboratories Corp. (Shenzhen) attests that all calibrations have been performed in accordance to requirements that traceable to National Primary Standards and International System of Units (SI).

Corrected Factor & Margin Calculation

The Corrected factor is calculated by adding LISN VDF (Voltage Division Factor), Cable Loss and Transient Limiter Attenuation. The basic equation is as follows:

$$\text{Correction Factor} = \text{LISN VDF} + \text{Cable Loss} + \text{Transient Limiter Attenuation}$$

The “**Margin**” column of the following data tables indicates the degree of compliance with the applicable limit. For example, a margin of 7 dB means the emission is 7 dB below the limit. The equation for margin calculation is as follows:

$$\text{Margin} = \text{Limit} - \text{Corrected Amplitude}$$

Test Results Summary

According to the recorded data in following table, the EUT complied with the FCC Part 15.107, the worst margin reading as below:

9.6 dB at 0.396030 MHz in the **Neutral** conducted mode

Refer to CISPR16-4-2:2011 and CISPR 16-4-1:2009, the measured level complies with the limit if

$$L_m + U_{(Lm)} \leq L_{lim} + U_{cispr}$$

In BACL., $U_{(Lm)}$ is less than U_{cispr} , if L_m is less than L_{lim} , it implies that the EUT complies with the limit.

Test Data

Environmental Conditions

Temperature:	26 °C
Relative Humidity:	54 %
ATM Pressure:	101.0 kPa

The testing was performed by William Li on 2014-09-19.

EUT Operation Mode: Running

AC 120V/60 Hz, Line

EMI Auto Test L

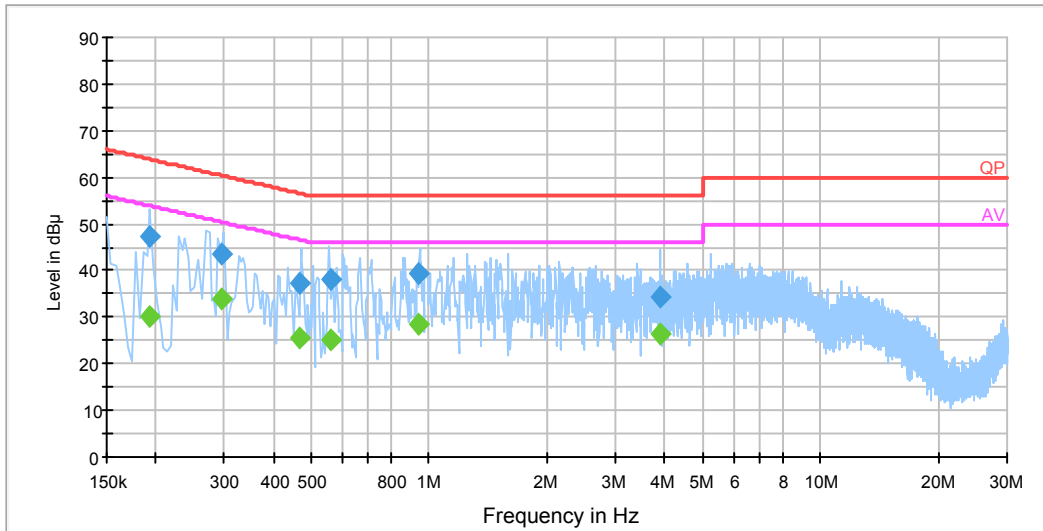

Frequency (MHz)	Corrected Amplitude (dB μ V)	Correction Factor (dB)	Limit (dB μ V)	Margin (dB)	Detector (PK/Ave./QP)
0.193500	47.2	19.6	63.9	16.7	QP
0.193500	30.2	19.6	53.9	23.7	Ave.
0.293500	43.5	19.4	60.4	16.9	QP
0.293500	33.7	19.4	50.4	16.7	Ave.
0.466950	37.4	19.6	56.6	19.2	QP
0.466950	25.6	19.6	46.6	21.0	Ave.
0.562310	38.0	19.6	56.0	18.0	QP
0.562310	25.1	19.6	46.0	20.9	Ave.
0.943810	39.4	19.5	56.0	16.6	QP
0.943810	28.4	19.5	46.0	17.6	Ave.
3.899350	34.3	19.7	56.0	21.7	QP
3.899350	26.2	19.7	46.0	19.8	Ave.

AC 120V/60 Hz, Neutral

EMI Auto Test N

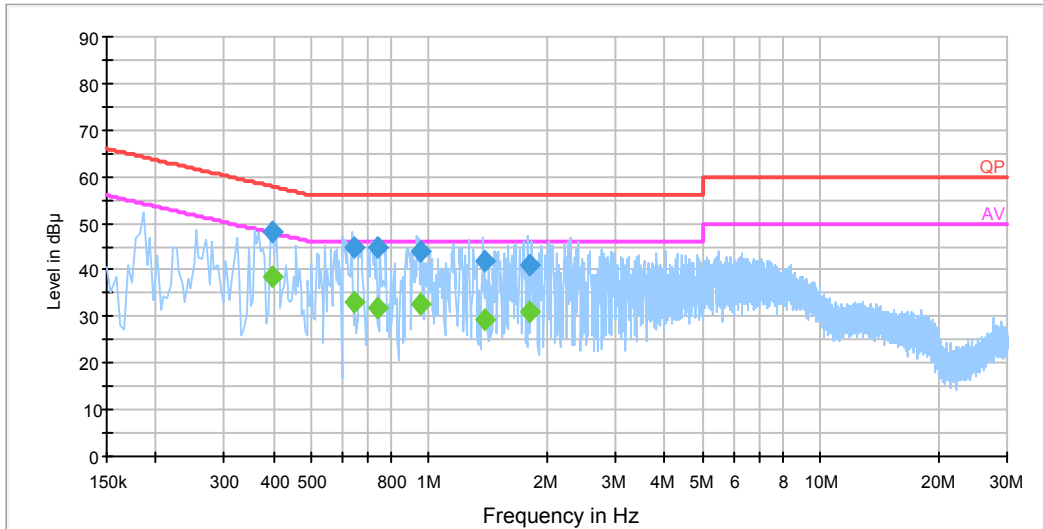

Frequency (MHz)	Corrected Amplitude (dBµV)	Correction Factor (dB)	Limit (dBµV)	Margin (dB)	Detector (PK/Ave./QP)
0.396030	48.3	19.6	57.9	9.6	QP
0.396030	38.3	19.6	47.9	9.6	Ave.
0.643510	44.8	19.6	56.0	11.2	QP
0.643510	32.9	19.6	46.0	13.1	Ave.
0.738750	44.9	19.6	56.0	11.1	QP
0.738750	31.8	19.6	46.0	14.2	Ave.
0.947990	44.2	19.5	56.0	11.8	QP
0.947990	32.6	19.5	46.0	13.4	Ave.
1.393390	41.7	19.5	56.0	14.3	QP
1.393390	29.3	19.5	46.0	16.7	Ave.
1.803150	41.2	19.6	56.0	14.8	QP
1.803150	30.9	19.6	46.0	15.1	Ave.

Note:

- 1) Correction Factor = LISN VDF (Voltage Division Factor) + Cable Loss + Transient Limiter Attenuation
- 2) Corrected Amplitude = Reading + Correction Factor
- 3) Margin = Limit – Corrected Amplitude

FCC §15.109 - RADIATED SPURIOUS EMISSIONS

Applicable Standard

FCC §15.109

Measurement Uncertainty

All measurements involve certain levels of uncertainties, especially in field of EMC. The factors contributing to uncertainties are spectrum analyzer, cable loss, antenna factor calibration, antenna directivity, antenna factor variation with height, antenna phase center variation, antenna factor frequency interpolation, measurement distance variation, site imperfections, mismatch (average), and system repeatability.

Based on CISPR 16-4-2:2011, the expended combined standard uncertainty of radiation emissions at Bay Area Compliance Laboratories Corp. (Shenzhen) is shown in below table. And the uncertainty will not be taken into consideration for the test data recorded in the report

Frequency	Polarity	Measurement uncertainty
30 MHz~200 MHz	Horizontal	4.62 dB (k=2, 95% level of confidence)
	Vertical	4.54 dB (k=2, 95% level of confidence)
200 MHz~1 GHz	Horizontal	4.84 dB (k=2, 95% level of confidence)
	Vertical	5.91 dB (k=2, 95% level of confidence)
1 GHz~6 GHz	Horizontal/Vertical	4.68 dB (k=2, 95% level of confidence)

EUT Setup

Below 1 GHz:

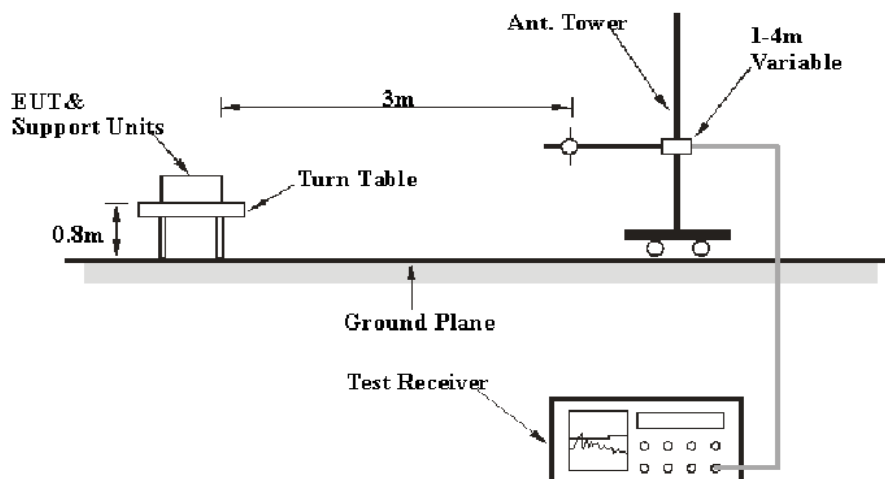

Above 1GHz:

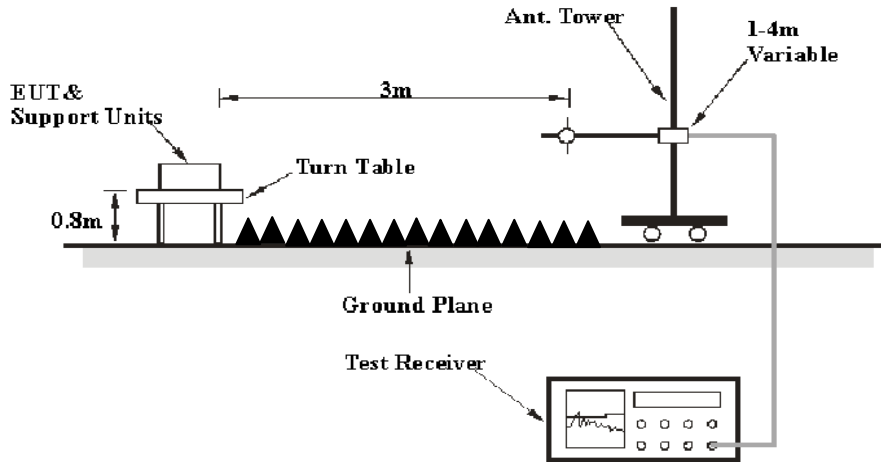

The radiated emission tests were performed in the 3 meters chamber test site, using the setup accordance with the ANSI C63.4-2009. The specification used was the FCC Part 15.109 Class B limits.

The external I/O cables were draped along the test table and formed a bundle 30 to 40 cm long in the middle.

The spacing between the peripherals was 10 cm.

The adapter was connected to a 120 VAC/60 Hz power source.

EMI Test Receiver Setup

Per §15.33 requirement, the system was investigated from 30 MHz to 2 GHz.

During the radiated emission test, the EMI test receiver was set with the following configurations:

Frequency Range	RBW	Video B/W	IF B/W	Detector
30 MHz – 1000 MHz	100 kHz	300 kHz	120 kHz	QP
Above 1 GHz	1MHz	3 MHz	/	PK
	1MHz	10 Hz	/	Ave.

Test Procedure

During the radiated emission test, the adapter was connected to the outlet of the first LISN, and the other relevant equipments were connected to the outlet of the second LISN.

Maximizing procedure was performed on the highest emissions to ensure that the EUT complied with all installation combinations.

All final data was recorded in the Quasi-peak detector mode from 30 MHz to 1 GHz and pk and average detector modes for frequencies above 1 GHz.

Test Equipment List and Details

Manufacturer	Description	Model	Serial Number	Calibration Date	Calibration Due Date
HP	Amplifier	8447E	1937A01046	2014-05-06	2015-05-06
Rohde & Schwarz	EMI Test Receiver	ESCI	101122	2013-09-25	2014-09-25
Sunol Sciences	Broadband Antenna	JB1	A040904-2	2011-11-28	2014-11-27
Mini	Amplifier	ZVA-183-S+	5969001149	2014-04-23	2015-04-23
A.H. System	Horn Antenna	SAS-200/571	135	2012-02-11	2015-02-10
Rohde & Schwarz	Signal Analyzer	FSIQ26	8386001028	2013-11-12	2014-11-12
TDK	Chamber	Chamber A	2#	2012-10-15	2015-10-15
TDK	Chamber	Chamber B	1#	2014-07-23	2015-07-23
R&S	Auto test Software	EMC32	V9.10	--	--

* **Statement of Traceability:** Bay Area Compliance Laboratories Corp. (Shenzhen) attests that all calibrations have been performed in accordance to requirements that traceable to National Primary Standards and International System of Units (SI).

Corrected Amplitude & Margin Calculation

The Corrected Amplitude is calculated by adding the Antenna Factor and Cable Loss, and subtracting the Amplifier Gain from the Meter Reading. The basic equation is as follows:

$$\text{Corrected Amplitude} = \text{Meter Reading} + \text{Antenna Factor} + \text{Cable Loss} - \text{Amplifier Gain}$$

The “**Margin**” column of the following data tables indicates the degree of compliance with the applicable limit. For example, a margin of 7 dB means the emission is 7 dB below the limit. The equation for margin calculation is as follows:

$$\text{Margin} = \text{Limit} - \text{Corrected Amplitude}$$

Test Results Summary

According to the data in the following table, the EUT complied with the FCC §15.109 Class B, the worst margin reading as below:

15.59 dB at 33.29 MHz in the Vertical polarization mode

Refer to CISPR16-4-2:2011 and CISPR 16-4-1:2009, the measured level complies with the limit if

$$L_m + U_{(L_m)} \leq L_{lim} + U_{cispr}$$

In BACL, $U_{(L_m)}$ is less than U_{cispr} , if L_m is less than L_{lim} , it implies that the EUT complies with the limit.

Test Data**Environmental Conditions**

Temperature:	26 °C
Relative Humidity:	54 %
ATM Pressure:	101.0 kPa

The testing was performed by William Li on 2014-09-23.

EUT Operation Mode: Running

30 MHz ~2 GHz

Frequency (MHz)	Receiver		Turntable Degree	Rx Antenna		Corrected Factor (dB/m)	Corrected Amplitude (dBµV/m)	FCC Part 15B	
	Reading (dBµV)	Detector (PK/QP/Ave.)		Height (m)	Polar (H/V)			Limit (dBµV/m)	Margin (dB)
33.29	33.11	QP	41	1.3	V	-8.7	24.41	40	15.59
49.64	27.69	QP	41	1.3	V	-19.4	8.29	40	31.71
53.75	29.18	QP	107	1.0	V	-20.1	9.08	40	30.92
166.74	38.00	QP	107	1.0	V	-14.3	23.70	43.5	19.80
417.37	37.92	QP	81	1.1	H	-9.8	28.12	46	17.88
500.16	31.28	QP	81	1.1	H	-8.6	22.68	46	23.32
1228.38	37.69	PK	86	1.6	V	0.13	37.82	74	36.18
1228.38	23.85	Ave.	86	1.6	V	0.13	23.98	54	30.02
2077.06	41.52	PK	20	1.6	V	3.23	44.75	74	29.25
2077.06	26.89	Ave.	20	1.6	V	3.23	30.12	54	23.88
3089.53	41.86	PK	299	1.4	H	9.37	51.23	74	22.77
3089.53	27.69	Ave.	299	1.4	H	9.37	37.06	54	16.94

Note:

- 1) Correction Factor=Antenna factor (RX) + cable loss – amplifier factor
- 2) Corrected Amplitude = Correction Factor + Reading
- 3) Margin = Limit - Corrected Amplitude

PRODUCT SIMILARITY DECLARATION LETTER



Kasda Digital Technology Co., Ltd.
B-31 Building, Tanglang Industry Zone, XiLi Nanshan, Shenzhen, China
Tel: +86 755 8609 6689 Fax: +86 755 8610 6137

2014/9/29

Product Similarity Declaration

To Whom It May Concern,

We, Kasda Digital Technology Co., Ltd., hereby declare that we have a product named as Wireless ADSL Router (Model number: KW5811) was tested by BACL, meanwhile, for our marketing purpose, we would like to list a series models (KW5811,CXB-1511,SN-1511) on reports and certificate, all the models are identical schematics only named differently.

We confirm that all information above is true, and we'll be responsible for all the consequences. Please contact me if you have any question.

Signature: *Xiong Ying*

Xiong, Ying

Purchasing Manager

******* END OF REPORT *******