

NAKANO CENTRAL PARK EAST
4-10-1 Nakano, Nakano-ku, Tokyo 164-8570, Japan
Phone : +81-3-6832-5247 Fax : +81-3-6832-1841
Registered Address: 2-31-11, Ningyo-cho, Nihonbashi, Chuo-ku, Tokyo 103-8650, Japan

April 10th, 2024

Antenna Under Test report

This document is test report of Wi-Fi/BT antenna of XL-85M/XL-CH2.

1. Summary

This antenna covers 2042 – 2484MHz and 4910 – 5825MHz. This antenna is installed on plastic case in unit's chassis, and it is connected to Wi-Fi/BT module via PCB trace.

2. Part name

MTD302248

3. Outline, dimension and material

3.1. Dimension

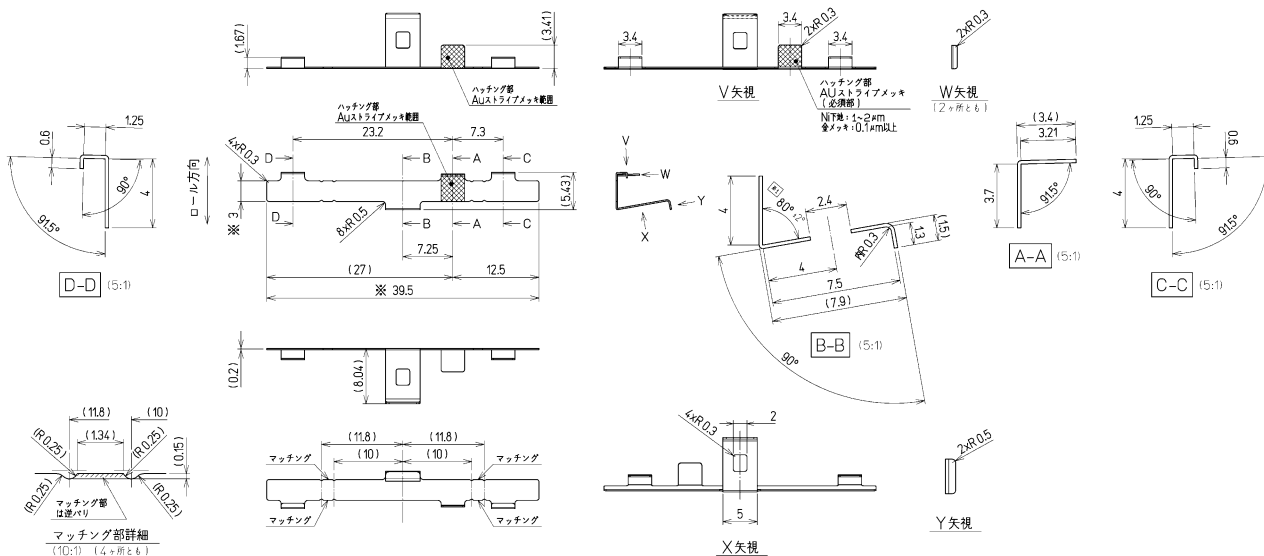

Figure 3 Outline dimension

3.2. Plating

Ni + Au

3.3. Material

C5210-1/2H (High Strength Phosphor Bronze for Springs, thickness = 0.2mm)

4. Characteristics

4.1. Frequency Range

For Bluetooth: 2402 – 2480MHz

For Wi-Fi (2.4GHz): 2412 – 2484MHz

For Wi-Fi (5GHz): 4910 – 5825MHz

4.2. Impedance

50 Ohm

4.3. Radiation pattern

4.3.1. Antenna with XL-85M

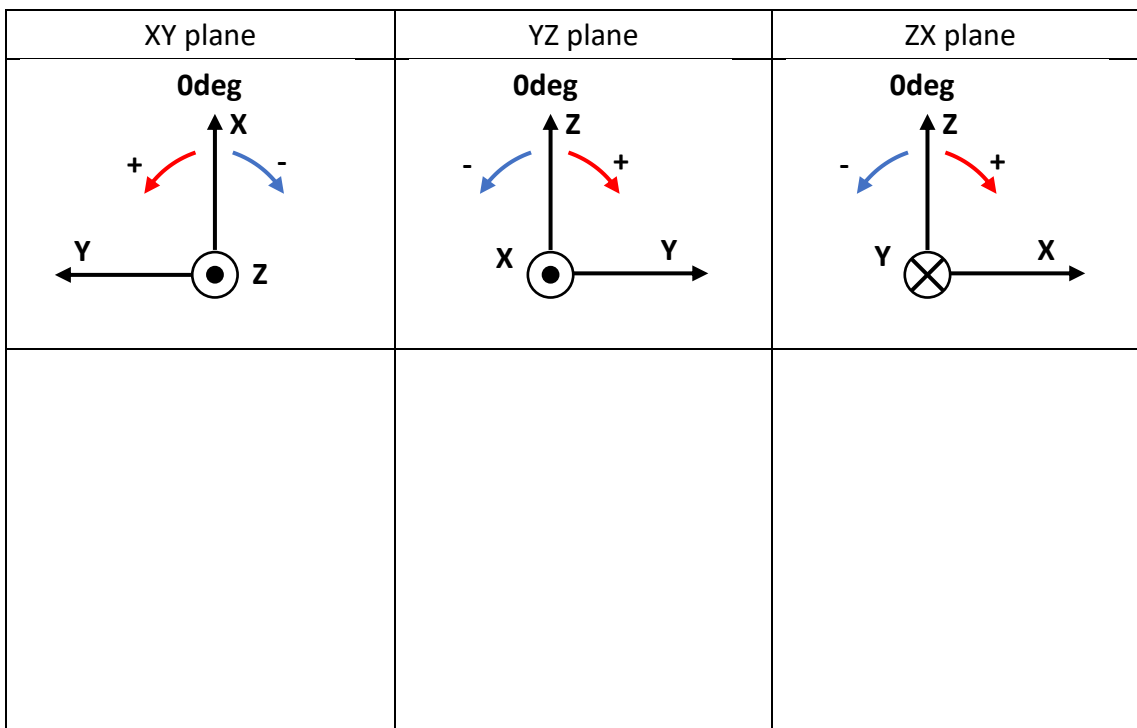

1) 2440MHz

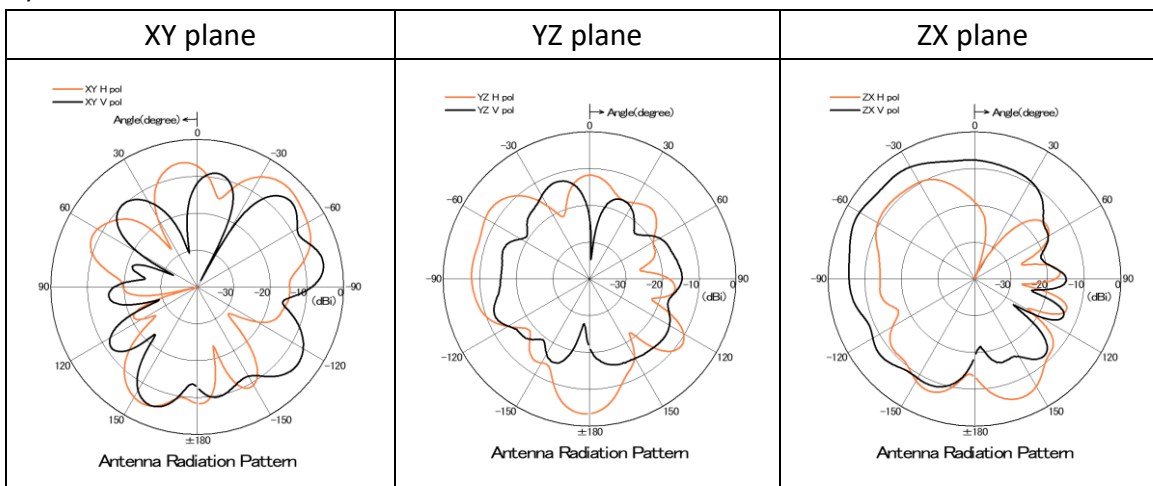

Peak Gain

	XY plane	YZ plane	ZX plane
H pol	-3.4dBi	-3.4dBi	-5.3dBi
V pol	-5.0dBi	-12.2dBi	-3.7dBi

2) 5200MHz

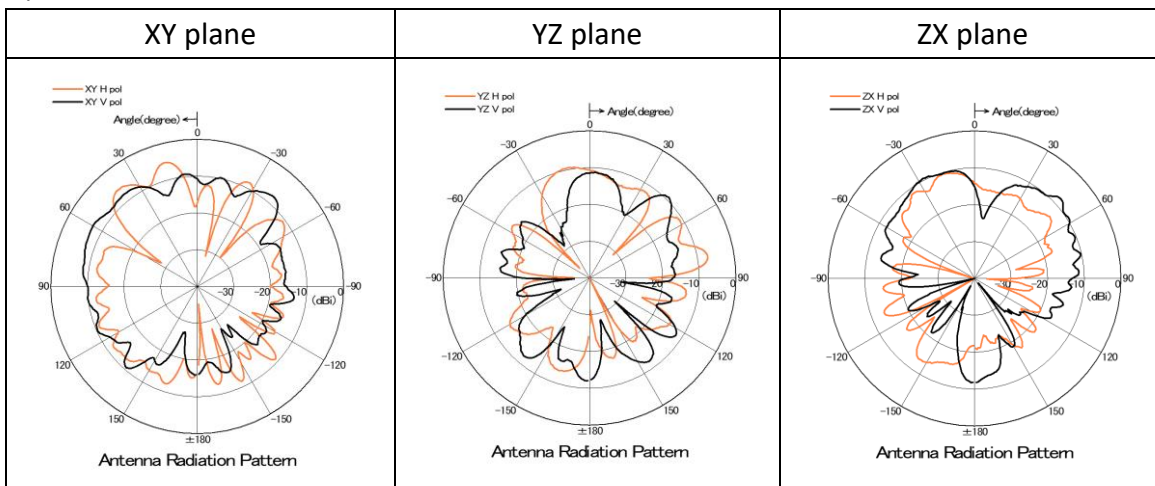

Peak Gain

	XY plane	YZ plane	ZX plane
H pol	-5.2dBi	-7.3dBi	-10.4dBi
V pol	-7.1dBi	-9.2dBi	-8.1dBi

3) 5785MHz

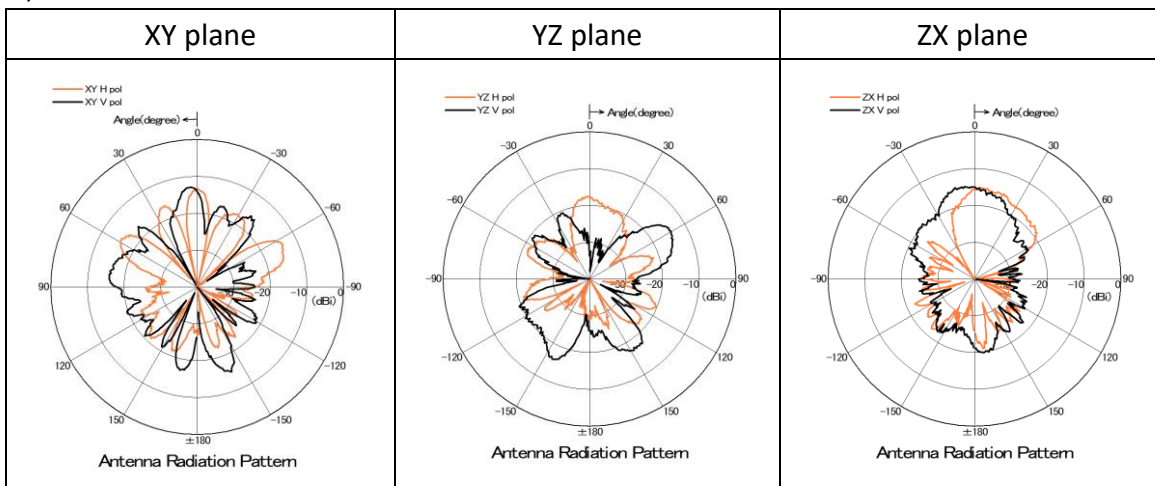

Peak Gain

	XY plane	YZ plane	ZX plane
H pol	-13.3dBi	-17.5dBi	-15.1dBi
V pol	-13.0dBi	-14.3dBi	-14.7dBi

4.3.2. Antenna with XL-CH2

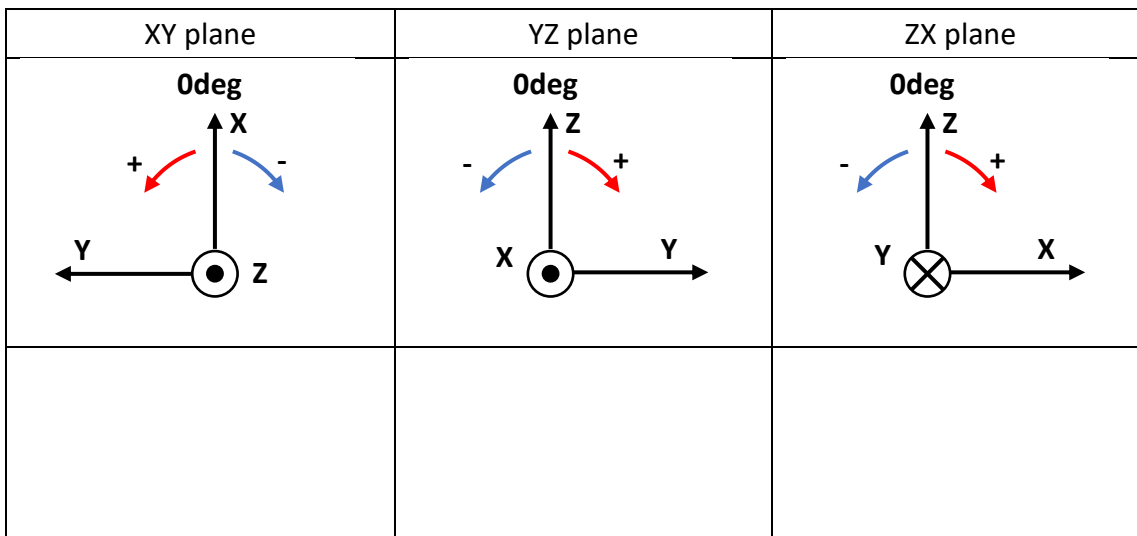

1) 2440MHz

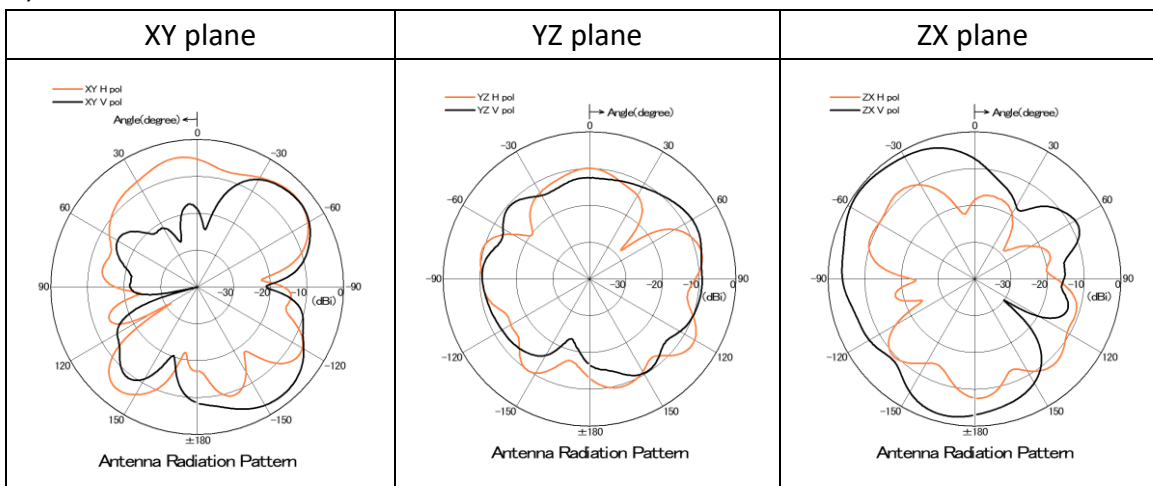

Peak Gain

	XY plane	YZ plane	ZX plane
H pol	-3.7dBi	-6.8dBi	-7.6dBi
V pol	-2.6dBi	-7.6dBi	-0.5dBi

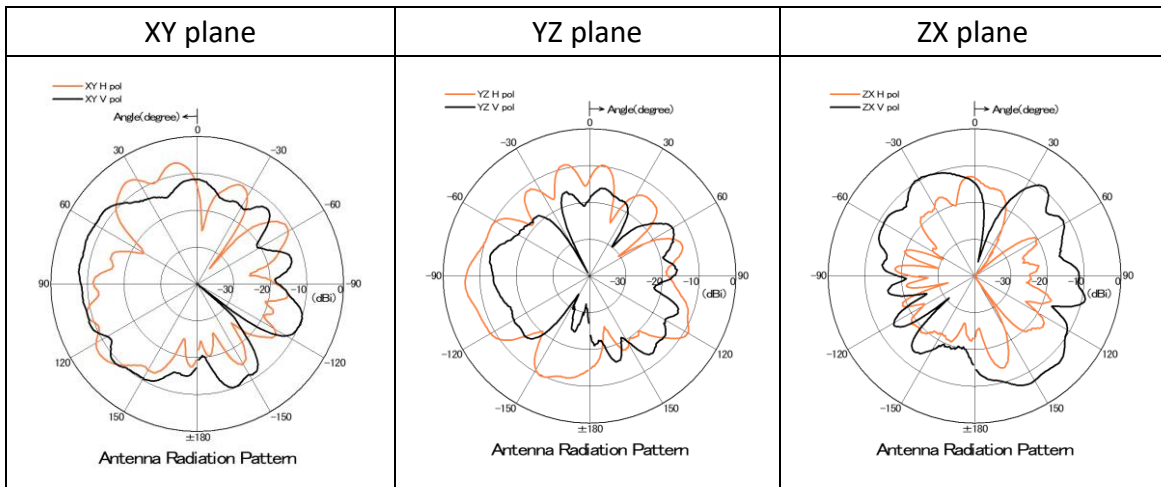
2) 5200MHz

Peak Gain

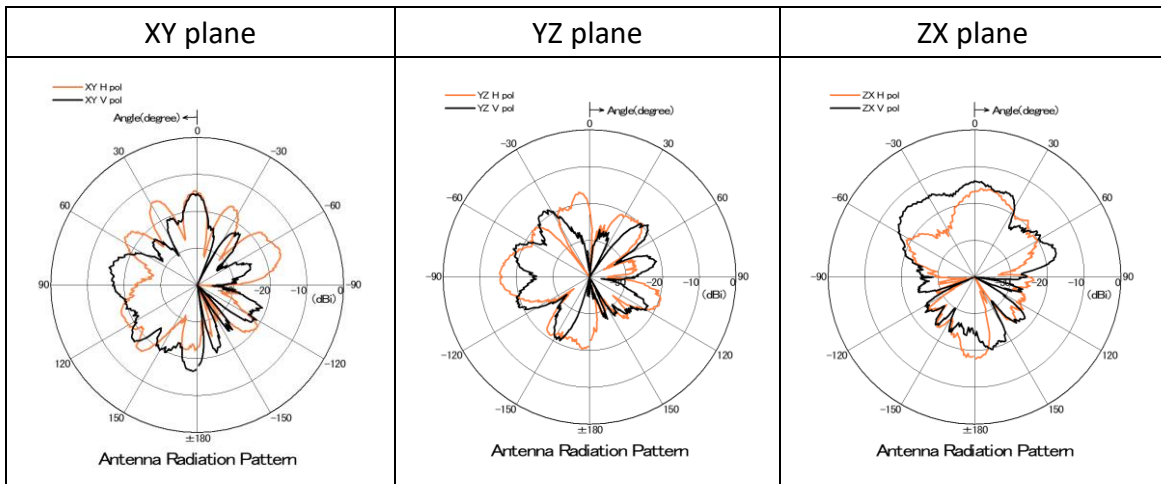
	XY plane	YZ plane	ZX plane
H pol	-6.3dBi	-6.0dBi	-12.9dBi
V pol	-7.4dBi	-12.3dBi	-7.0dBi

3) 5785MHz

Peak Gain

	XY plane	YZ plane	ZX plane
H pol	-14.5dBi	-15.5dBi	-15.9dBi
V pol	-15.2dBi	-17.8dBi	-13.5dBi

5. Measurement

5.1. Test Site

“Electromagnetic anechoic chamber-C” in JRC Nagano-site

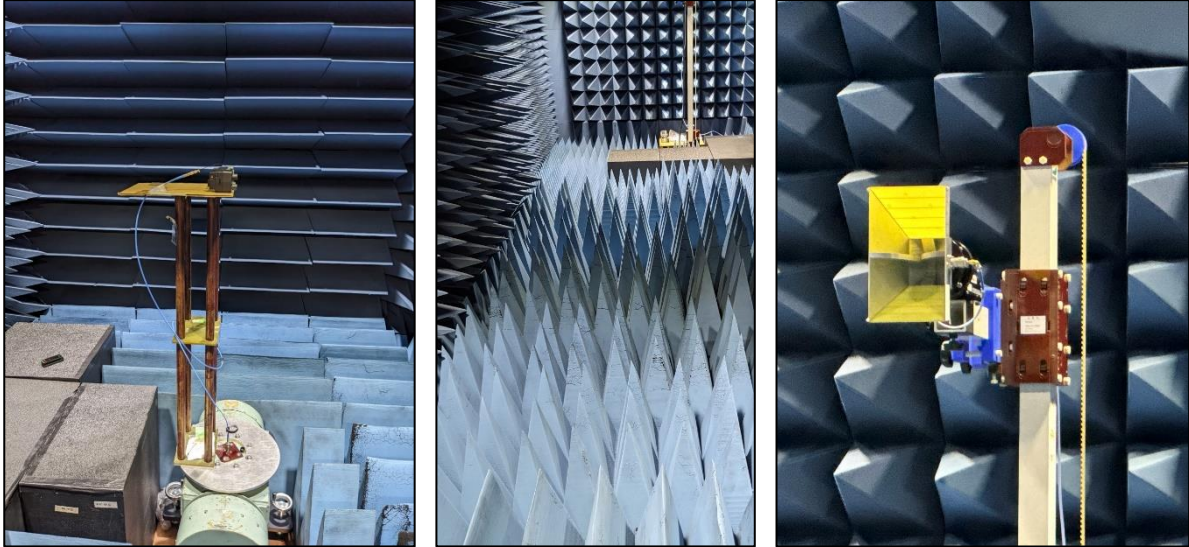

Figure 4 Pictures of test-site

5.2. Test equipment

Table 1 Test equipment

Manufacture	Model	Part Type	Serial Number	Calibration due date
Keysight	N5224A	Network Analyzer	05-14213	Aug. 2024
Keysight	N4985A	Microwave Amplifier	91-16007	Aug. 2024
KRYTAR	2610	Directional Coupler	91-15043	Aug. 2024
Keysight	8498A	Attenuator	74-1-098	Jun. 2024
Sunol Sciences Corp.	DRH-118	Tx antenna	90-17002-4	Aug. 2024
FLANN MICROWAVE	08240	standard antenna (2.4GHz)	No.30582	Aug. 2024
FLANN MICROWAVE	12240	standard antenna (5.0GHz)	No.59	Aug. 2024

5.3. Test method

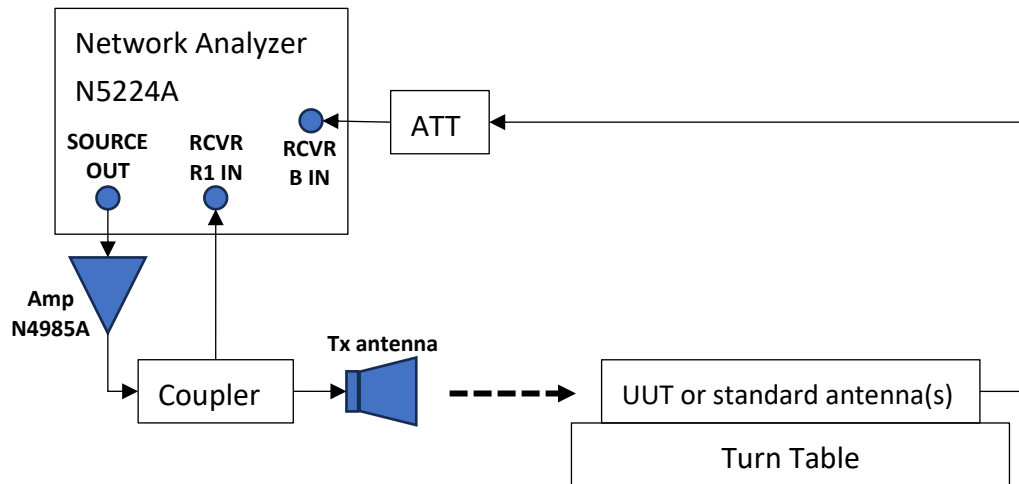

Figure 5 Test setup

- 1) Set UUT on Turntable.
- 2) Connect Network Analyzer and UUT according to test setup.
- 3) Adjust angle of Tx antenna by using the level.
- 4) Adjust angle of UUT by using the level.
- 5) Adjust the height position of Tx antenna and UUT by using laser marking instrument.
- 6) Check the height of UUT antenna by using laser range finder.
- 7) Turn on output of Network Analyzer and start transmission by using Tx antenna.
- 8) Measure UUT antenna's receiving level by using Network Analyzer while rotating turntable.
- 9) Change plane of polarization of Tx antenna, then measure UUT antenna's receiving level by using Network Analyzer while rotating turntable.
- 10) Change axis of UUT (XY -> YZ), then repeat measurement process 8)-9).
- 11) Change axis of UUT (YZ -> ZX), then repeat measurement process 8)-9).
- 12) Remove UUT, then set standard antenna (2.4GHz) with same height as 6).
- 13) Repeat measurement process 8)-11).
- 14) Remove standard antenna (2.4GHz), then set standard antenna (5.0GHz) with same height as 6).
- 15) Repeat measurement process 8)-11).
- 16) Calculate antenna gain of UUT from measurement result of 8)-15).

End of File