



Engineering Solutions & Electromagnetic Compatibility Services

**Certification Application Report
FCC Part 15.247 & ISED RSS-247**

Test Lab: Rhein Tech Laboratories, Inc. Phone: 703-689 0368 360 Herndon Parkway www.rheintech.com Suite 1400 Herndon, VA 20170 E-Mail: atcbinfo@rheintech.com		Applicant: Harris Corporation 221 Jefferson Ridge Parkway Lynchburg, VA 24501 USA	
FCC ID/IC	OWDTR-0161-E/ 3636B-0161	Test Report Date	October 3, 2019
Platform	N/A	RTL Work Order #	2019062
Model / Model #/HVIN	XL-200M / XZ-MPM1M	RTL Quote Number	QRTL19-062A
American National Standard Institute	ANSI C63.10-2013 American National Standard of Procedures for Compliance Testing of Unlicensed Wireless Devices		
FCC Classification	DTS – Part 15 Digital Transmission System (Wi-Fi)		
FCC Rule Part(s)	FCC Rules Part 15.247: Operation within the bands 902-928 MHz, 2400-2483.5 MHz and 5725-5850 MHz (10-01-18)		
ISED Standards	RSS-247 Issue 2: Digital Transmission Systems (DTSs), Frequency Hopping Systems (FHSs) and Licence-Exempt Local Area Network (LE-LAN) Devices RSS-Gen Issue 5: General Requirements for Compliance of Radio Apparatus		
Frequency Range (MHz)	Output Power (mW) Peak Conducted	Frequency Tolerance	Emission Designator
2412 – 2462	5.2	N/A	16M4FXD
2412 – 2462	4.3	N/A	16M6FXD
2412 – 2462	4.6	N/A	16M6FXD

I, the undersigned, hereby declare that the equipment tested and referenced in this report conforms to the identified standard(s) as described in this test report. No modifications were made to the equipment during testing in order to achieve compliance with these standards. Furthermore, there was no deviation from, additions to, or exclusions from, the applicable parts of FCC Part 2, FCC Part 15, ANSI C63.10, and ISED RSS-247 and RSS-Gen.

Signature: 

Date: October 3, 2019

Typed/Printed Name: Desmond A. Fraser

Position: President

These tests are accredited and meet the requirements of ISO/IEC 17025 as verified by ANAB. Refer to certificate and scope of accreditation AT-1445. This report replaces R0.0.

This report may not be reproduced, except in full, without the written approval of Rhein Tech Laboratories, Inc. and Harris Corporation. The test results relate only to the item(s) tested.

Table of Contents

1	General Information	5
1.1	Scope	5
1.2	Description of EUT	5
1.3	Test Facility	5
1.4	Related Submittal(s)/Grant(s)	5
1.5	Modifications	5
2	Test Information	6
2.1	Description of Test Modes	6
2.2	Exercising the EUT	6
2.3	Test Result Summary	6
2.4	Tested System Details	7
2.5	Configuration of Tested System	8
3	Peak Output Power – FCC 15.247(b)(1); RSS-247 5.4(b), RSS-Gen 6.12	9
3.1	Power Output Test Procedure	9
3.2	Power Output Test Results	9
4	Control Head Compliance with the Band Edge – FCC 15.247(d); RSS-247 5.5	10
4.1	Band Edge Test Procedure	10
4.2	Restricted Band Edge Test Results	10
4.3	Band Edge Plots	11
5	Antenna Conducted Spurious Emissions – FCC 15.247(d); RSS-247 5.5, RSS-Gen 6.13	15
5.1	Antenna Conducted Spurious Emissions Test Procedures	15
5.2	Antenna Conducted Spurious Emissions Test Results	15
6	Bandwidths – FCC 15.247(a)(1); RSS-247 5.1(a); RSS-Gen 6.7	16
6.1	Bandwidth Test Procedure	16
6.2	Modulated Bandwidth Test Results	16
6.3	Bandwidth Plots	17
7	Power Spectral Density – FCC 15.247(e); RSS-247 5.2(b)	23
7.1	Power Spectral Density Test Procedure	23
7.2	Power Spectral Density Test Results	23
7.3	Power Spectral Density Plots	24
8	AC Conducted Emissions – FCC 15.207; RSS-Gen 8.8	27
9	Radiated Emissions – FCC 15.209; RSS-247 5.5; RSS-Gen 8.9, 8.10	28
9.1	Limits of Radiated Emissions Measurement	28
9.2	Radiated Emissions Measurement Test Procedure	28
9.3	Radiated Emissions Test Results	29
10	Conclusion	35

Figure Index

Figure 2-1: Configuration of System Under Test.....8

Table Index

Table 2-1: Channels Tested for Wi-Fi – 802.11b (11 Mbps); 802.11g (54 Mbps); 802.11n (6.5 Mbps) ..6
 Table 2-2: Test Result Summary – FCC Part 15, Subpart C (Section 15.247); ISED RSS-247, RSS-Gen6
 Table 2-3: Equipment Under Test (EUT).....7
 Table 2-4: Support Equipment.....7
 Table 2-5: Auxiliary Equipment7
 Table 3-1: Power Output Test Equipment.....9
 Table 3-2: Power Output Test Data – 802.11 (11.0 Mbps)9
 Table 4-1: Band Edge Test Equipment10
 Table 4-2: Lower Band Edge - Average – 802.11 (11.0 Mbps).....11
 Table 4-3: Lower Band Edge - Peak – 802.11 (11.0 Mbps).....12
 Table 4-4: Upper Band Edge - Average – 802.11 (11.0 Mbps).....13
 Table 4-5: Upper Band Edge - Peak – 802.11 (11.0 Mbps).....14
 Table 5-1: Antenna Conducted Spurious Emissions Test Equipment15
 Table 6-1: Bandwidth Test Equipment16
 Table 6-2: Modulated Bandwidth Test Data – 802.11 (11.0 Mbps).....16
 Table 7-1: Power Spectral Density Test Data – 802.11 (11.0 Mbps).....23
 Table 9-1: Radiated Emissions Test Equipment29
 Table 9-2: Radiated Emissions Harmonics/Spurious – 2412 MHz, Peak Detector; 802.11b29
 Table 9-3: Radiated Emissions Harmonics/Spurious – 2412 MHz, Average Detector; 802.11b29
 Table 9-4: Radiated Emissions Harmonics/Spurious – 2437 MHz, Peak Detector; 802.11b30
 Table 9-5: Radiated Emissions Harmonics/Spurious – 2437 MHz, Average Detector; 802.11b30
 Table 9-6: Radiated Emissions Harmonics/Spurious – 2462 MHz, Peak Detector; 802.11b30
 Table 9-7: Radiated Emissions Harmonics/Spurious – 2462 MHz, Average Detector; 802.11b30
 Table 9-8: Radiated Emissions Harmonics/Spurious – 2412 MHz, Peak Detector; 802.11g31
 Table 9-9: Radiated Emissions Harmonics/Spurious – 2412 MHz, Average Detector; 802.11g31
 Table 9-10: Radiated Emissions Harmonics/Spurious – 2437 MHz, Peak Detector; 802.11g31
 Table 9-11: Radiated Emissions Harmonics/Spurious – 2437 MHz, Average Detector; 802.11g31
 Table 9-12: Radiated Emissions Harmonics/Spurious – 2462 MHz, Peak Detector; 802.11g32
 Table 9-13: Radiated Emissions Harmonics/Spurious – 2462 MHz, Average Detector; 802.11g32
 Table 9-14: Radiated Emissions Harmonics/Spurious – 2412 MHz, Peak Detector; 802.11n32
 Table 9-15: Radiated Emissions Harmonics/Spurious – 2412 MHz, Average Detector; 802.11n32
 Table 9-16: Radiated Emissions Harmonics/Spurious – 2437 MHz, Peak Detector; 802.11n33
 Table 9-17: Radiated Emissions Harmonics/Spurious – 2437 MHz, Average Detector; 802.11n33
 Table 9-18: Radiated Emissions Harmonics/Spurious – 2462 MHz, Peak Detector; 802.11n33
 Table 9-19: Radiated Emissions Harmonics/Spurious – 2462 MHz, Average Detector; 802.11n33
 Table 9-20: Unintentional Emissions Test Data34

Plot Index

Plot 4-1:	Lower Band Edge – Average – 802.11 (11.0 Mbps).....	11
Plot 4-2:	Lower Band Edge – Peak – 802.11 (11.0 Mbps).....	12
Plot 4-3:	Upper Band Edge – Average – 802.11 (11.0 Mbps).....	13
Plot 4-4:	Upper Band Edge – Peak – 802.11 (11.0 Mbps).....	14
Plot 6-1:	6 dB Bandwidth – 2412 MHz – 802.11 (11.0 Mbps).....	17
Plot 6-2:	6 dB Bandwidth – 2437 MHz – 802.11 (11.0 Mbps).....	18
Plot 6-3:	6 dB Bandwidth – 2462 MHz – 802.11 (11.0 Mbps).....	19
Plot 6-4:	99% Bandwidth – 2412 MHz – 802.11 (11.0 Mbps).....	20
Plot 6-5:	99% Bandwidth – 2437 MHz – 802.11 (11.0 Mbps).....	21
Plot 6-6:	99% Bandwidth – 2462 MHz – 802.11 (11.0 Mbps).....	22
Plot 7-1:	Power Spectral Density – 2412 MHz – 802.11 (11.0 Mbps).....	24
Plot 7-2:	Power Spectral Density – 2437 MHz – 802.11 (11.0 Mbps).....	25
Plot 7-3:	Power Spectral Density – 2462 MHz – 802.11 (11.0 Mbps).....	26

Appendix Index

Appendix A:	Test Photographs.....	36
-------------	-----------------------	----

Photograph Index

Photograph 1:	Radiated Emissions Testing – Front View (Above 1 GHz).....	36
Photograph 2:	Radiated Emissions Testing – Back View (Above 1 GHz).....	37
Photograph 3:	Radiated Emissions Testing – Front View (Below 1 GHz).....	38
Photograph 4:	Radiated Emissions Testing – Back View (Below 1 GHz).....	39

1 General Information

1.1 Scope

Applicable Standards

- FCC Part 15.247: Frequency Hopping, Direct Spread Spectrum and Hybrid Systems that are in operation within the bands of 902-928 MHz, 2400-2483.5 MHz and 5725-5850 MHz
- ISED RSS-247: Digital Transmission Systems (DTSS), Frequency Hopping Systems (FHSs) and Licence-Exempt Local Area Network (LE-LAN) Devices
- ISED RSS-Gen Issue 5: General Requirements for Compliance of Radio Apparatus

1.2 Description of EUT

Equipment Under Test	Mobile Radio
Model / Model #	XL-200M / XZ-MPM1M
Power Supply	13.6 VDC
Modulation Type	CCK, DSSS, OFDM (802.11b/g/n)
Frequency Range	2412–2462 MHz

1.3 Test Facility

The open area test site and conducted measurement facility used to collect the radiated data is located at 360 Herndon Parkway, Suite 1400, Herndon, Virginia 20170. This site has been fully described in a report and approved by the Federal Communications Commission to perform AC line conducted and radiated emissions testing (ANSI C63.10-2013).

1.4 Related Submittal(s)/Grant(s)

This is an original certification application for Harris Corporation Model XL-200M, Model #/HVIN: XZ-MPM1M, FCC ID: OWDTR-0161-E, IC: 3636B-0161.

1.5 Modifications

No modifications were required for compliance.

2 Test Information

2.1 Description of Test Modes

In accordance with FCC 15.31(m), and because the EUT utilizes an operating band greater than 10 MHz, the following frequencies were tested.

Table 2-1: Channels Tested for Wi-Fi – 802.11b (11 Mbps); 802.11g (54 Mbps); 802.11n (6.5 Mbps)

Channel (#)	Frequency (MHz)
1	2412
6	2437
11	2462

2.2 Exercising the EUT

The EUT was tested in all three orthogonal planes in order to determine worst-case emissions. The EUT was provided with software to continuously transmit during testing. The carrier was also checked to verify that information was being transmitted, and all modes were investigated and the worst-case mode was used for final testing. There were no deviations from the test standard(s) and/or methods. The test results reported relate only to the item tested.

2.3 Test Result Summary

Table 2-2: Test Result Summary – FCC Part 15, Subpart C (Section 15.247); ISED RSS-247, RSS-Gen

FCC	ISED	Test	Result
FCC 15.207	RSS-Gen 8.8	AC Conducted Emissions	N/A
FCC 15.209	RSS-247 5.5; RSS-Gen 8.9, 8.10	Radiated Emissions	Pass
FCC 15.247(a)(2)	RSS-247 5.2(a)	6 dB Bandwidth	Pass
FCC 15.247(b)(1)	RSS-247 5.4(b); RSS-Gen 6.12	Maximum Peak Power Output	Pass
FCC 15.247(d)	RSS-247 5.5; RSS-Gen 6.13	Antenna Conducted Spurious Emissions	Pass
FCC 15.247(d)	RSS-247 5.5	Band Edge Measurement	Pass
FCC 15.247(e)	RSS-247 5.2(b)	Power Spectral Density	Pass
N/A	RSS-Gen 6.7	99% Bandwidth	Pass

2.4 Tested System Details

The test samples were received on September 4, 2018. The FCC identifiers for all applicable equipment, plus descriptions of all cables used in the tested system, are identified in the following tables.

Table 2-3: Equipment Under Test (EUT)

Part	Manufacturer	Model/ HVIN	Serial Number	FCC ID	RTL Bar Code
Vehicular Communication Hub (VCH)	Harris Corporation	XL-200M/ XZ-MPM1M	048	OWDTR-0161-E	23081
Control Head	Harris Corporation	XL-CH Mobile Control Head/ N/A	085	OWDTR-0161-E	23080

Table 2-4: Support Equipment

Part	Manufacturer	Model	PN/SN	FCC ID	RTL Bar Code
Laptop	ASUS	N550J	F2N0CY33003067G	N/A	N/A

Table 2-5: Auxiliary Equipment

Part	Manufacturer	Model	PN/SN	FCC ID	RTL Bar Code
USB Mobile Mic	N/A	USB Mobile Mic	14050-6010-01/V22e	N/A	22756
Remote Speaker	N/A	Remote Speaker	14050-6100-01	N/A	N/A
Analog Deskmic	N/A	Analog Deskmic	MC-014121-003	N/A	N/A
CH Mounting Kit	N/A	CH Mounting Kit	14050-6210-01	N/A	N/A
VCH Mounting Kit	N/A	VCH Mounting Kit	14050-6200-01	N/A	N/A
Ethernet Cable, overmold, 45cm	N/A	N/A	14050-6300-01	N/A	N/A
Ethernet Cable, overmold, 9m	N/A	N/A	14050-6300-02	N/A	N/A
DC power cables (CH)	N/A	N/A	CA-012616-001	N/A	N/A
DC power cables (VCH)	N/A	N/A	CA-012365-001	N/A	N/A

2.5 Configuration of Tested System

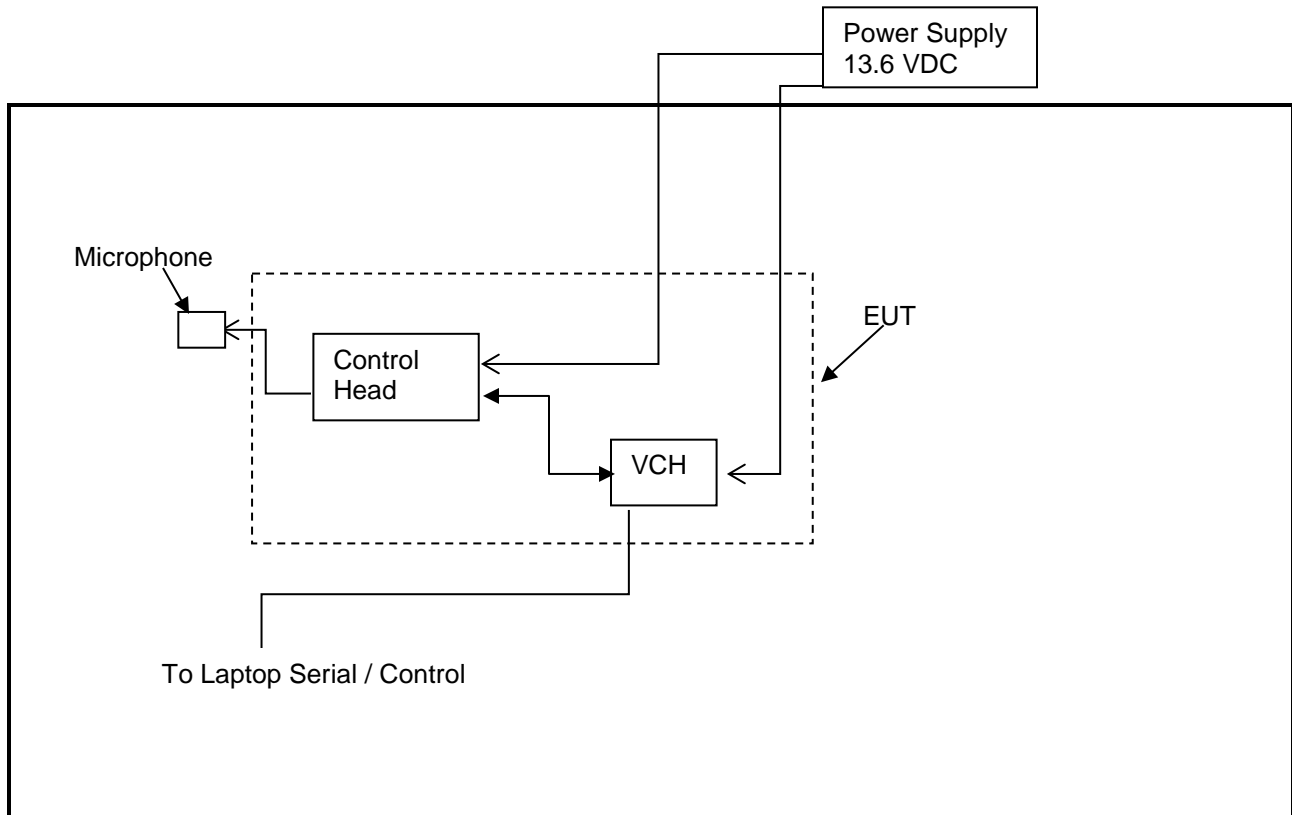

Figure 2-1: Configuration of System Under Test

3 Peak Output Power – FCC 15.247(b)(1); RSS-247 5.4(b), RSS-Gen 6.12

3.1 Power Output Test Procedure

A conducted power measurement of the EUT was taken using an Agilent Analyzer. The following settings were used:

- 1) Span: Approximately five times the 20 dB bandwidth, centered on a hopping channel (5 MHz used)
- 2) RBW >20 dB bandwidth of the emission being measured (2 MHz used)
- 3) VBW ≥RBW (3 MHz used)
- 4) Sweep: Auto
- 5) Detector function: Peak
- 6) Trace: Max hold. The trace was allowed to stabilize, and the marker-to-peak function was used to set the marker to the peak of the emission.

Table 3-1: Power Output Test Equipment

RTL Asset #	Manufacturer	Model	Part Type	Serial Number	Calibration Due Date
901583	Agilent Technologies	N9010A	EXA Signal Analyzer (10 Hz-26.5 GHz)	MY51250846	2/6/20

3.2 Power Output Test Results

Table 3-2: Power Output Test Data – 802.11 (11.0 Mbps)

Channel (#)	Frequency (MHz)	Conducted Peak Power (dBm)	Limit (dBm)	Margin (dB)
1	2412	6.9	30.0	-23.1
6	2437	7.1	30.0	-22.9
11	2462	7.2	30.0	-22.8

Note: EUT was programmed to TX with 11.0 Mbps rate, 20 MHz bandwidth and 10 dBm power level for all three test frequencies.

Highest conducted peak power measured: 7.2 dBm ≈ 5.2 mW

$$P(\text{Watts}) = 10^{(\text{dBm} / 10)} / 1000$$

Measurement uncertainty: ±0.5 dB. This measurement uncertainty is an expanded uncertainty for 95% confidence level received with a coverage factor k=2.

Results: Pass

Test Personnel:

Khue Do
 Test Engineer

 Signature

September 7, 2018
 Date of Test

4 Control Head Compliance with the Band Edge – FCC 15.247(d); RSS-247 5.5

4.1 Band Edge Test Procedure

The transmitter output was connected to its appropriate antenna. 1 MHz integrated peak (100 kHz RBW/300 kHz VBW) and 1 MHz integrated average (100 MHz RBW/300 kHz VBW) corrected measurements were taken within the restricted band to show compliance.

Table 4-1: Band Edge Test Equipment

RTL Asset #	Manufacturer	Model	Part Type	Serial Number	Calibration Due Date
901583	Agilent Technologies	N9010A	EXA Signal Analyzer (10 Hz-26.5 GHz)	MY51250846	2/6/20

4.2 Restricted Band Edge Test Results

Note: EUT was programmed to TX with 11.0 Mbps rate, 20 MHz bandwidth and 10 dBm power level for all three test frequencies.

Conversion of dBm to dBμV/m at 3 m.

$$\text{dB}\mu\text{V}/\text{m} = \text{dBm} + 104.7 - (20 * \text{LOG}(3\text{m})) = \text{dBm} + 95.2$$

4.3 Band Edge Plots

Plot 4-1: Lower Band Edge – Average – 802.11 (11.0 Mbps)

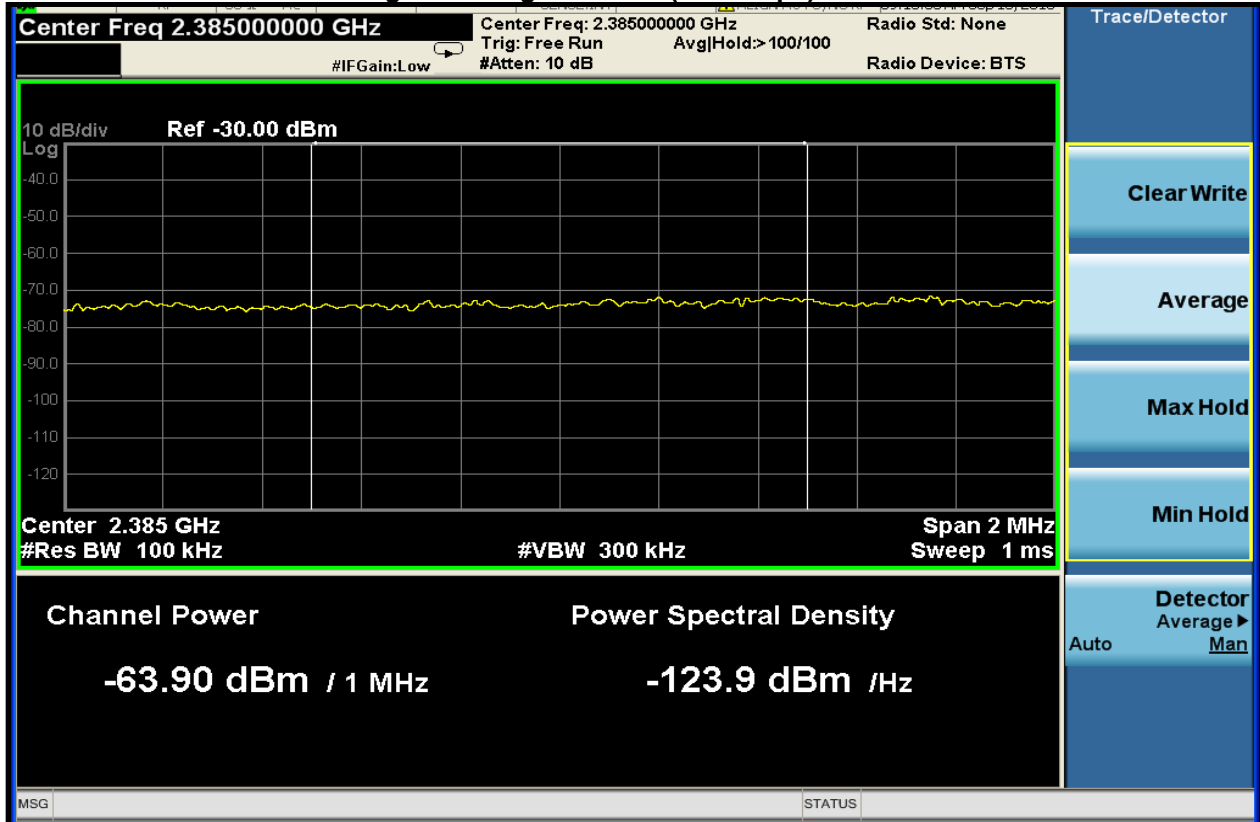

Table 4-2: Lower Band Edge - Average – 802.11 (11.0 Mbps)

Frequency (MHz)	Measured Average Level (dBm)	Field Strength Conversion (dBµV/m)	Average Limit (dBµV/m)	Margin (dB)
2385.0	-63.9	31.3	54.0	-22.7

Plot 4-2: Lower Band Edge – Peak – 802.11 (11.0 Mbps)

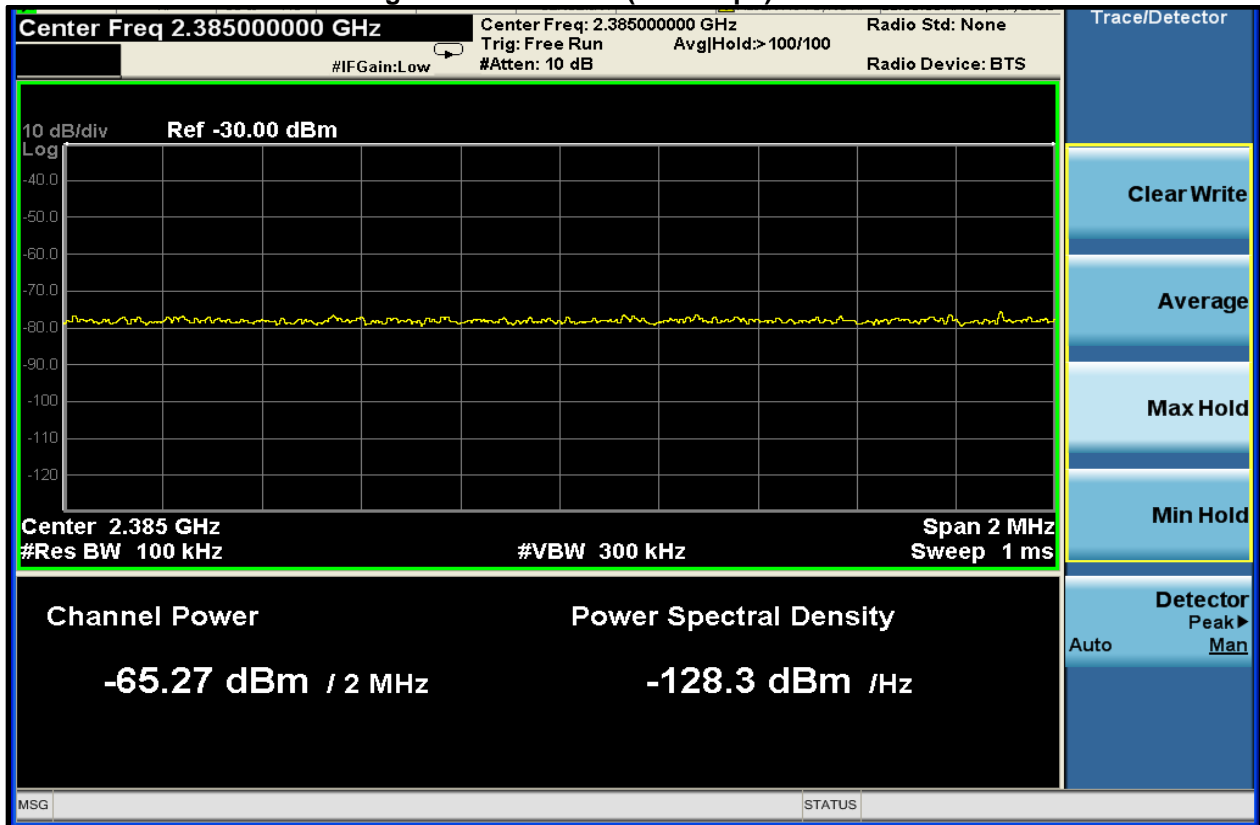

Table 4-3: Lower Band Edge - Peak – 802.11 (11.0 Mbps)

Frequency (MHz)	Measured Peak Level (dBm)	Field Strength Conversion (dB μ V/m)	Peak Limit (dB μ V/m)	Margin (dB)
2484.0	-65.3	29.9	74.0	-44.1

Plot 4-3: Upper Band Edge – Average – 802.11 (11.0 Mbps)

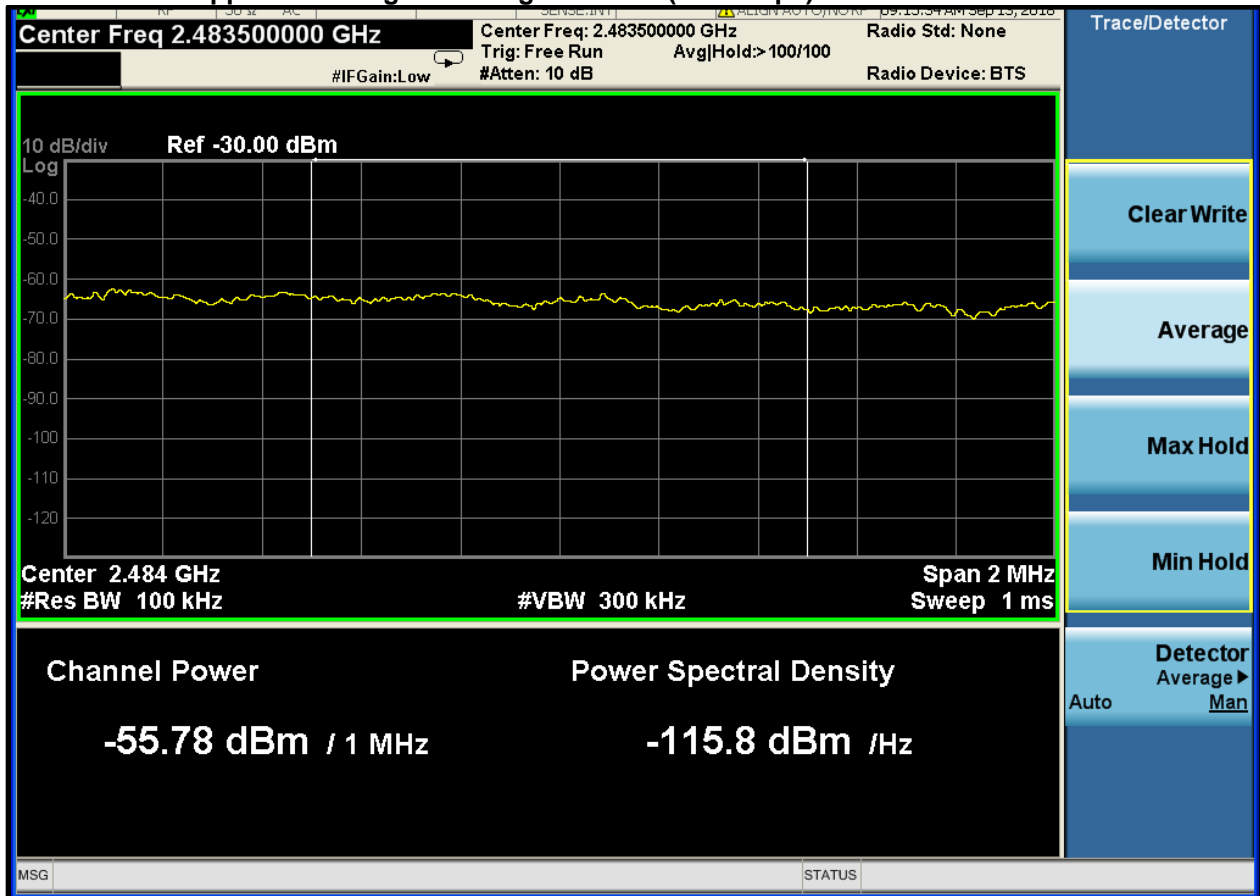

Table 4-4: Upper Band Edge - Average – 802.11 (11.0 Mbps)

Frequency (MHz)	Measured Average Level (dBm)	Field Strength Conversion (dBμV/m)	Average Limit (dBμV/m)	Margin (dB)
2484.0	-55.8	39.4	54.0	-14.6

Plot 4-4: Upper Band Edge – Peak – 802.11 (11.0 Mbps)

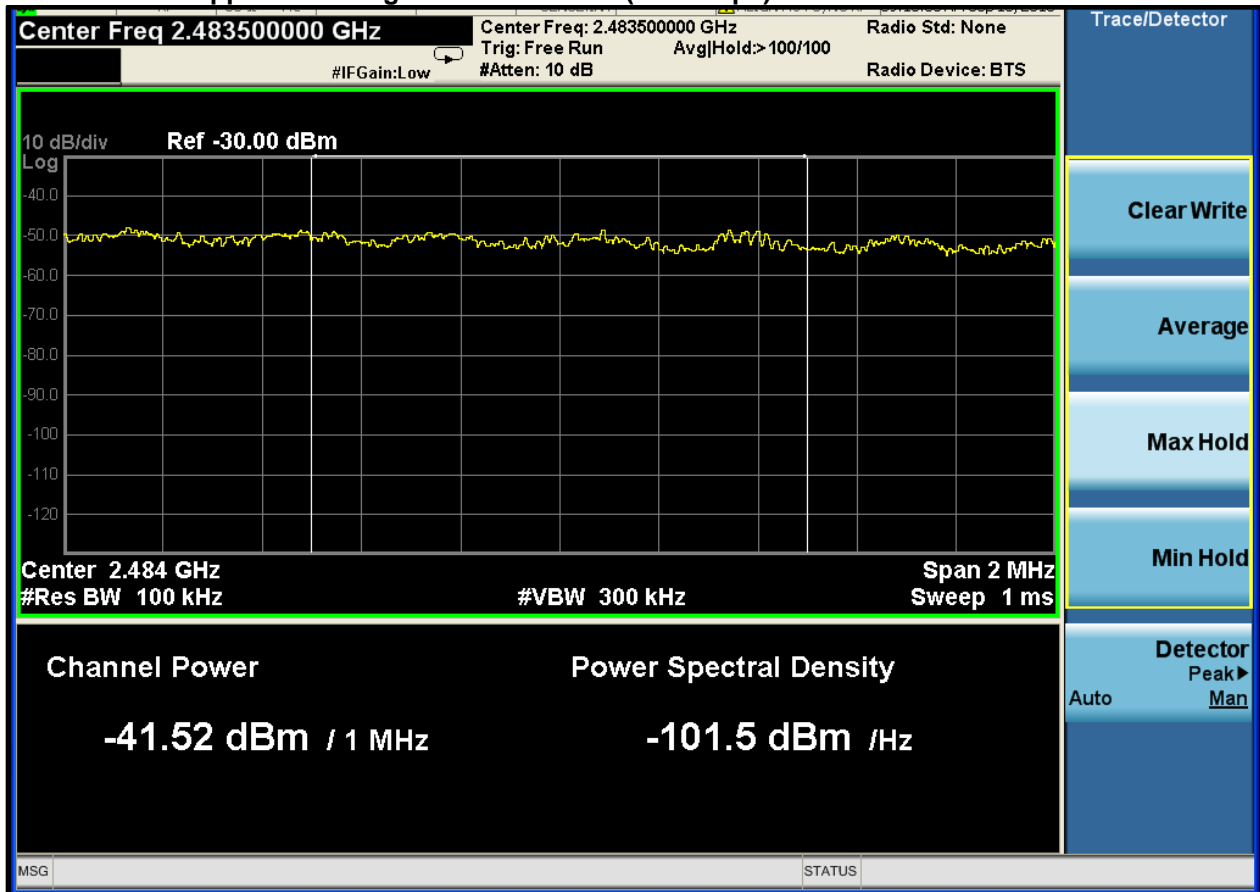

Table 4-5: Upper Band Edge - Peak – 802.11 (11.0 Mbps)

Frequency (MHz)	Measured Peak Level (dBm)	Field Strength Conversion (dBμV/m)	Peak Limit (dBμV/m)	Margin (dB)
2484.0	-41.5	53.7	74.0	-20.3

Measurement uncertainty: ±0.5 dB. This measurement uncertainty is an expanded uncertainty for 95% confidence level received with a coverage factor k=2.

Results: Pass

Test Personnel:

Khue Do
 Test Engineer

[Signature]
 Signature

September 13, 2018
 Date of Test

5 Antenna Conducted Spurious Emissions – FCC 15.247(d); RSS-247 5.5, RSS-Gen 6.13

5.1 Antenna Conducted Spurious Emissions Test Procedures

Antenna spurious emissions per FCC 15.247(d) were measured from the EUT antenna port using a 50-ohm spectrum analyzer with the resolution bandwidth set at 100 kHz, and the video bandwidth set at 100 kHz. The modulated carrier was identified at the following frequencies: 2412 MHz, 2437 MHz and 2462 MHz.

5.2 Antenna Conducted Spurious Emissions Test Results

Note: EUT was programmed to TX with 11.0 Mbps rate, 20 MHz bandwidth and 10 dBm power level for all three test frequencies.

No harmonics or spurs were found within 20 dB (note that we are reporting power as peak) of the carrier level from the carrier to the 10th harmonic of the carrier frequency.

Table 5-1: Antenna Conducted Spurious Emissions Test Equipment

RTL Asset #	Manufacturer	Model	Part Type	Serial Number	Calibration Due Date
901583	Agilent Technologies	N9010A	EXA Signal Analyzer (10 Hz-26.5 GHz)	MY51250846	2/6/20

Measurement uncertainty: ±0.5 dB. This measurement uncertainty is an expanded uncertainty for 95% confidence level received with a coverage factor k=2.

Results: Pass

Test Personnel:

Khue Do Test Engineer	 Signature	September 12, 2018 Date of Test
--------------------------	--	------------------------------------

6 Bandwidths – FCC 15.247(a)(1); RSS-247 5.1(a); RSS-Gen 6.7

6.1 Bandwidth Test Procedure

The minimum 6 dB and 99% bandwidths per FCC 15.247(a)(1), RSS-247 5.1(a) and RSS-Gen 6.7 were measured using a 50-ohm spectrum analyzer with the resolution bandwidth set at 100 kHz, and the video bandwidth set at $\geq 3 \times$ RBW. The device was modulated, (VBW) shall not be smaller than three times the RBW value. Video averaging is not permitted.

The maximum 6 dB bandwidth shall be 500 kHz.

Table 6-1: Bandwidth Test Equipment

RTL Asset #	Manufacturer	Model	Part Type	Serial Number	Calibration Due Date
901583	Agilent Technologies	N9010A	EXA Signal Analyzer (10 Hz-26.5 GHz)	MY51250846	2/6/20

6.2 Modulated Bandwidth Test Results

Table 6-2: Modulated Bandwidth Test Data – 802.11 (11.0 Mbps)

Frequency (MHz)	6 dB Bandwidth (MHz)	99% Bandwidth (MHz)
2412	15.14	16.249
2437	15.13	16.412
2462	15.14	16.250

6.3 Bandwidth Plots

Plot 6-1: 6 dB Bandwidth – 2412 MHz – 802.11 (11.0 Mbps)

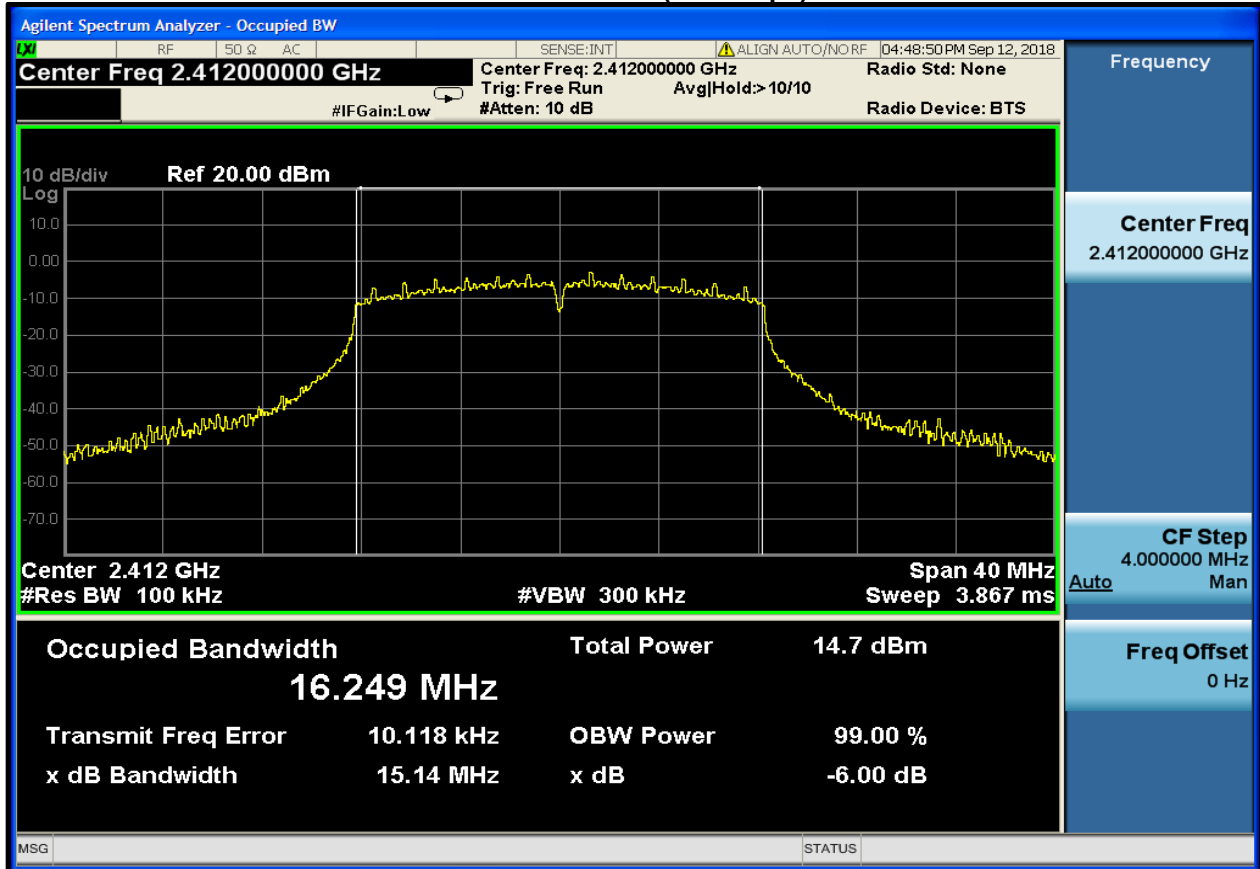

Plot 6-2: 6 dB Bandwidth – 2437 MHz – 802.11 (11.0 Mbps)

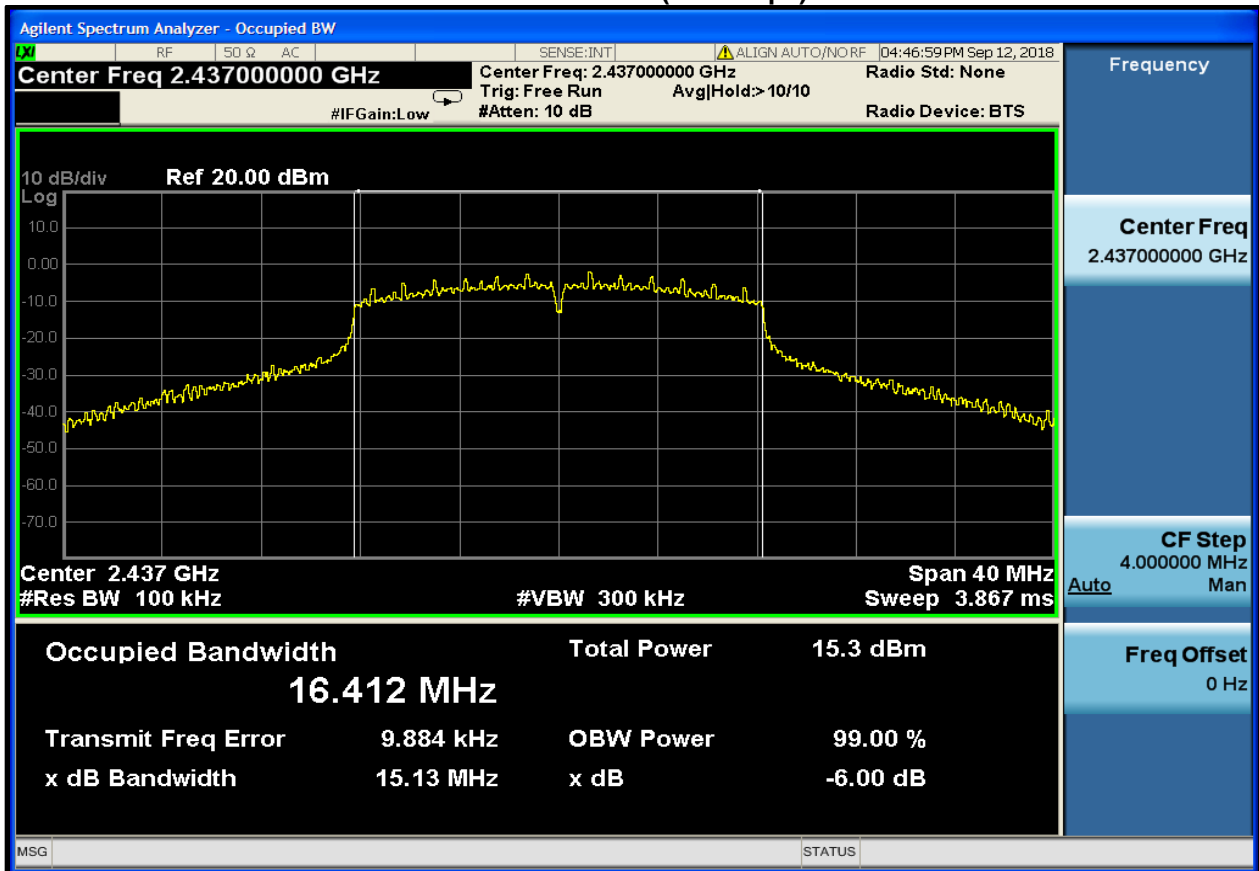

Plot 6-3: 6 dB Bandwidth – 2462 MHz – 802.11 (11.0 Mbps)

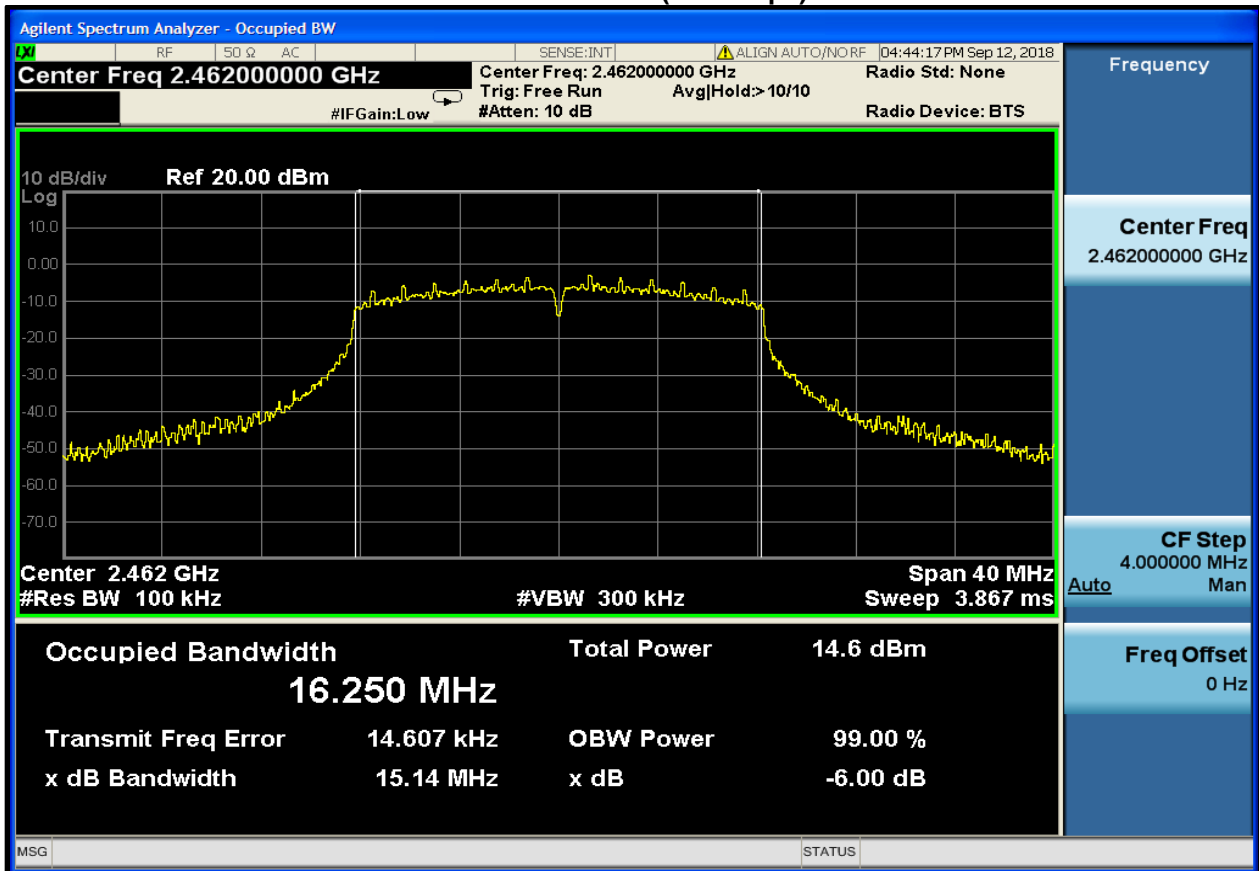

Plot 6-4: 99% Bandwidth – 2412 MHz – 802.11 (11.0 Mbps)

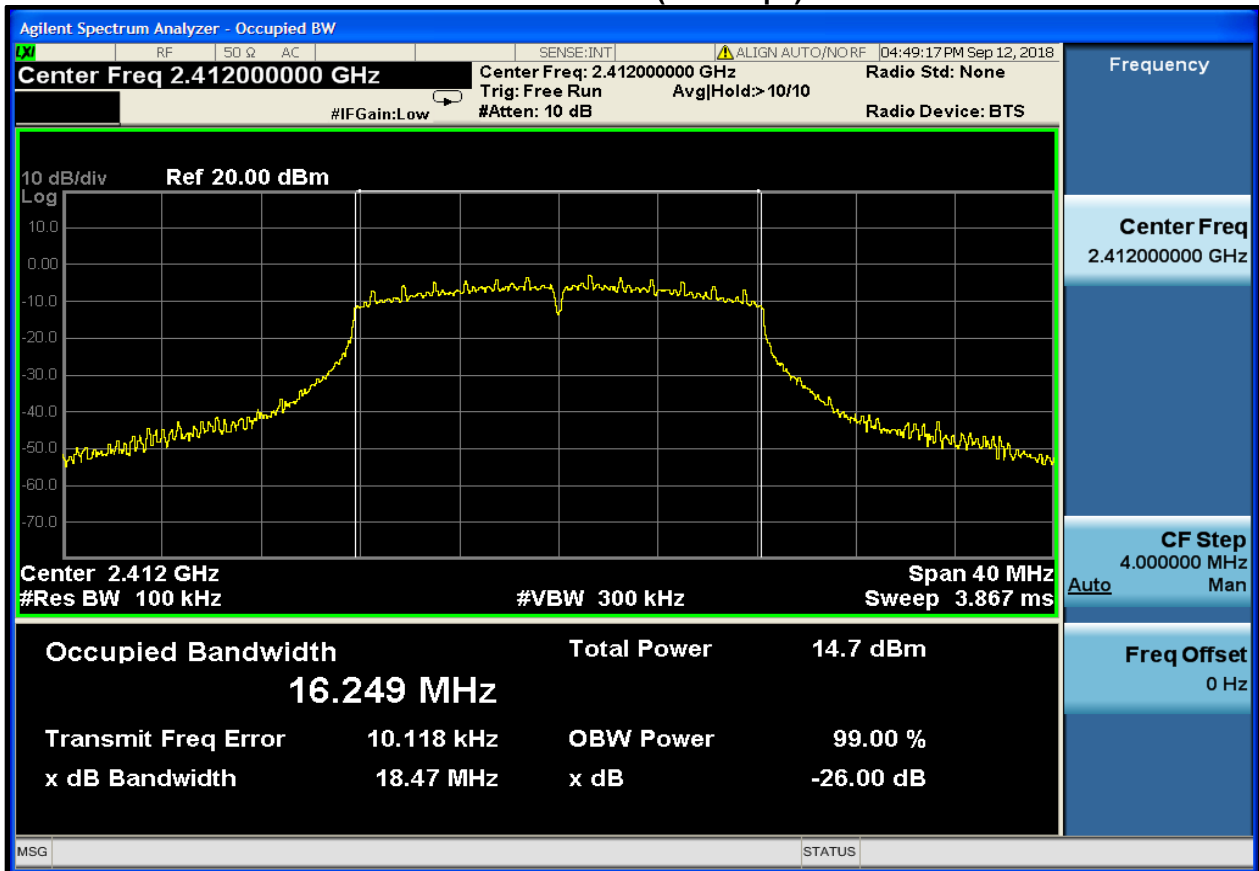

Plot 6-5: 99% Bandwidth – 2437 MHz – 802.11 (11.0 Mbps)

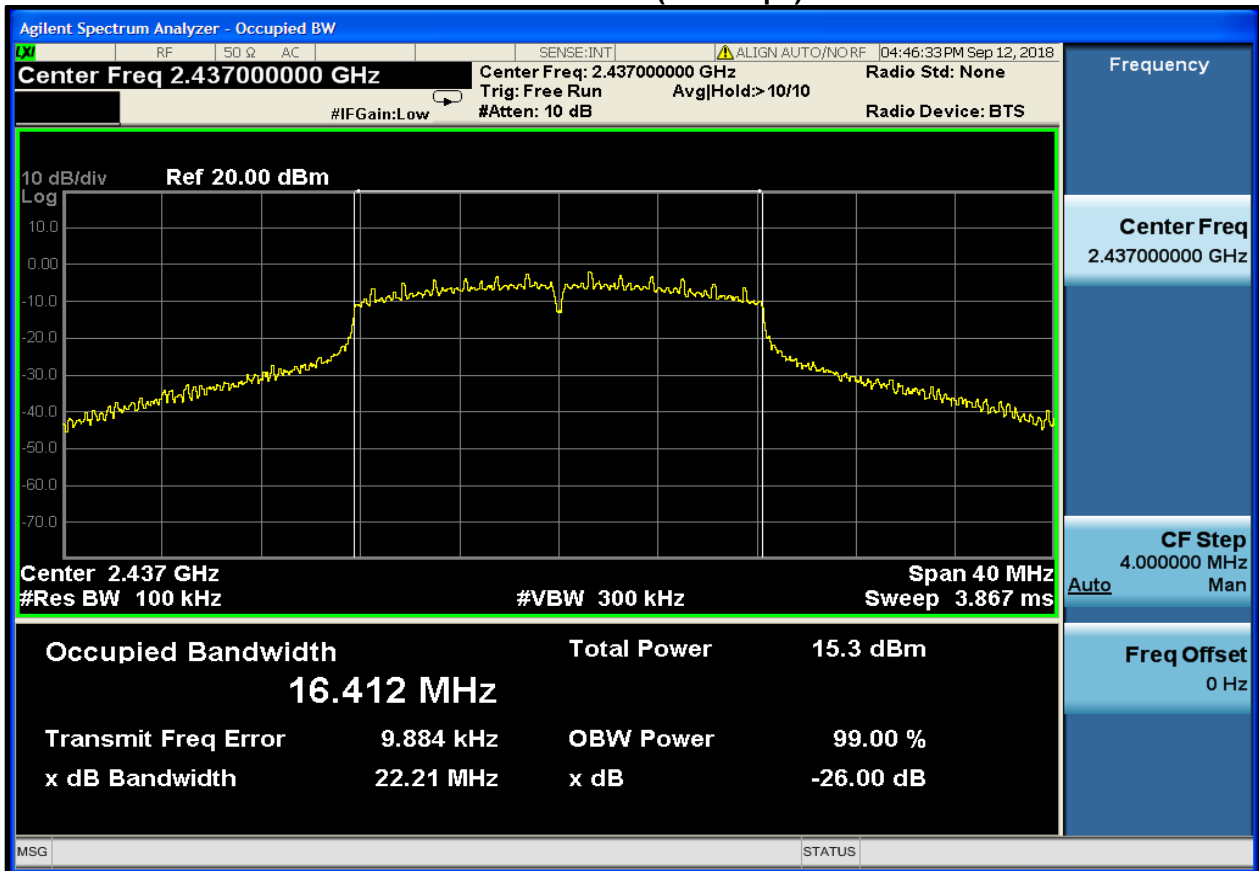

Plot 6-6: 99% Bandwidth – 2462 MHz – 802.11 (11.0 Mbps)

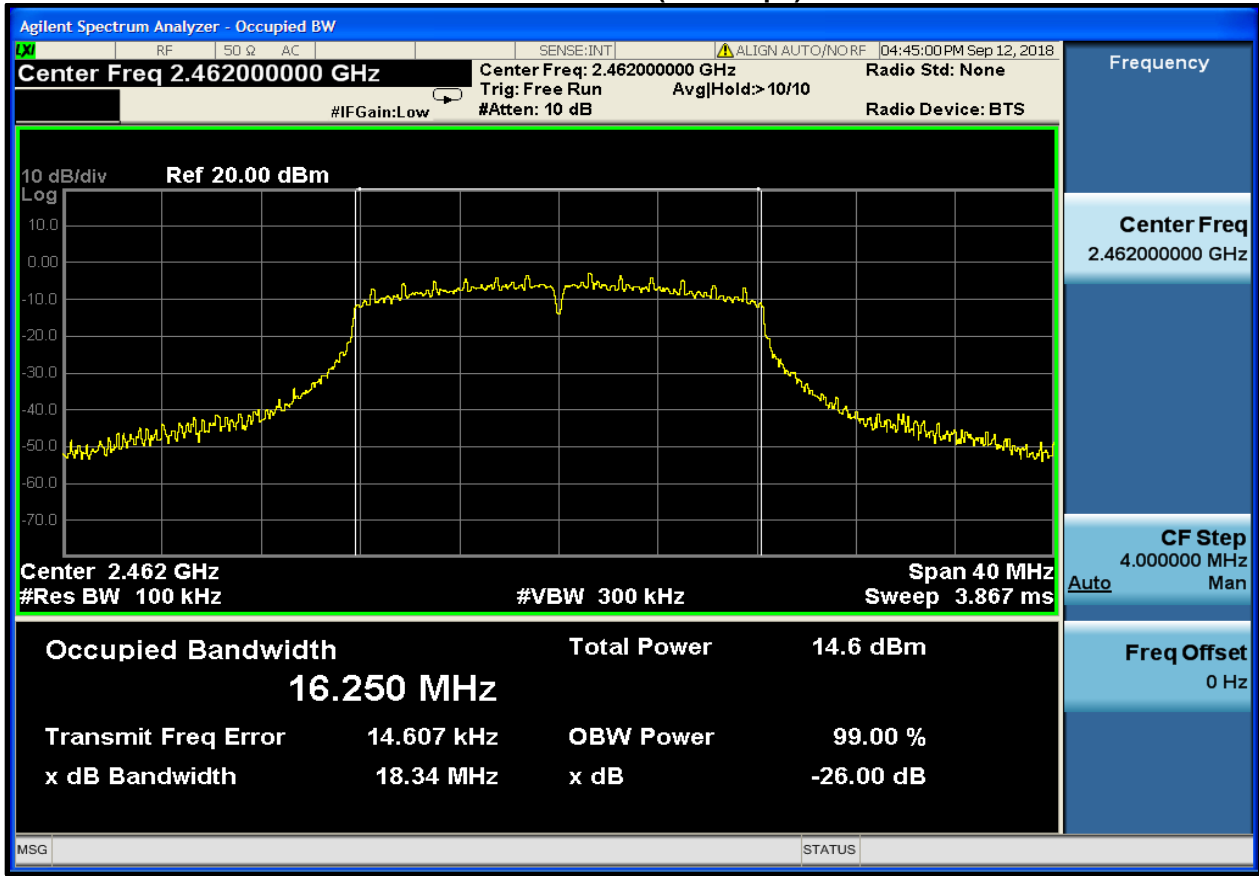

Measurement uncertainty: $\pm 1 \times 10^{-6}$ Hz. This measurement uncertainty is an expanded uncertainty for 95% confidence level received with a coverage factor $k=2$.

Test Personnel:

Khue Do
 Test Engineer

[Handwritten Signature]
 Signature

September 12, 2018
 Date of Test

7 Power Spectral Density – FCC 15.247(e); RSS-247 5.2(b)

7.1 Power Spectral Density Test Procedure

The power spectral density per FCC 15.247(e) was measured using a 50-ohm spectrum analyzer with the resolution bandwidth set at 3 kHz, the video bandwidth set at 30 kHz, and the auto sweep time. The spectral lines were resolved for the modulated carriers at 2412 MHz, 2437 MHz, and 2462 MHz for Wi-Fi. These levels are below the +8 dBm limit.

7.2 Power Spectral Density Test Results

Note: EUT was programmed to TX with 11.0 Mbps rate, 20 MHz bandwidth and 10 dBm power level for all three test frequencies.

Table 7-1: Power Spectral Density Test Data – 802.11 (11.0 Mbps)

Frequency (MHz)	PSD (dBm)	Limit (dBm)	Margin (dB)	Result (Pass / Fail)
2412	-15.9	8.0	-23.9	Pass
2437	-14.9	8.0	-22.9	Pass
2462	-15.9	8.0	-23.9	Pass

7.3 Power Spectral Density Plots

Plot 7-1: Power Spectral Density – 2412 MHz – 802.11 (11.0 Mbps)

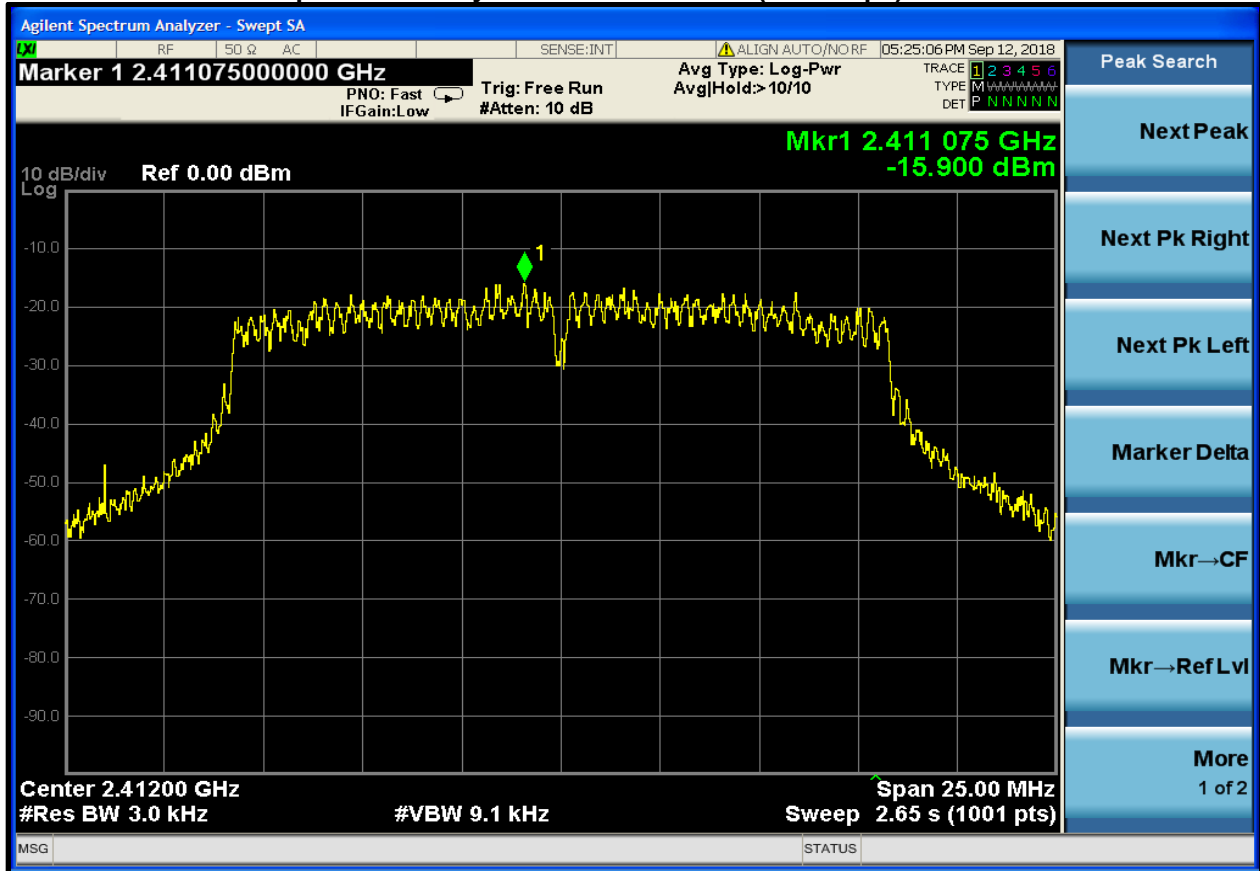

Plot 7-2: Power Spectral Density – 2437 MHz – 802.11 (11.0 Mbps)

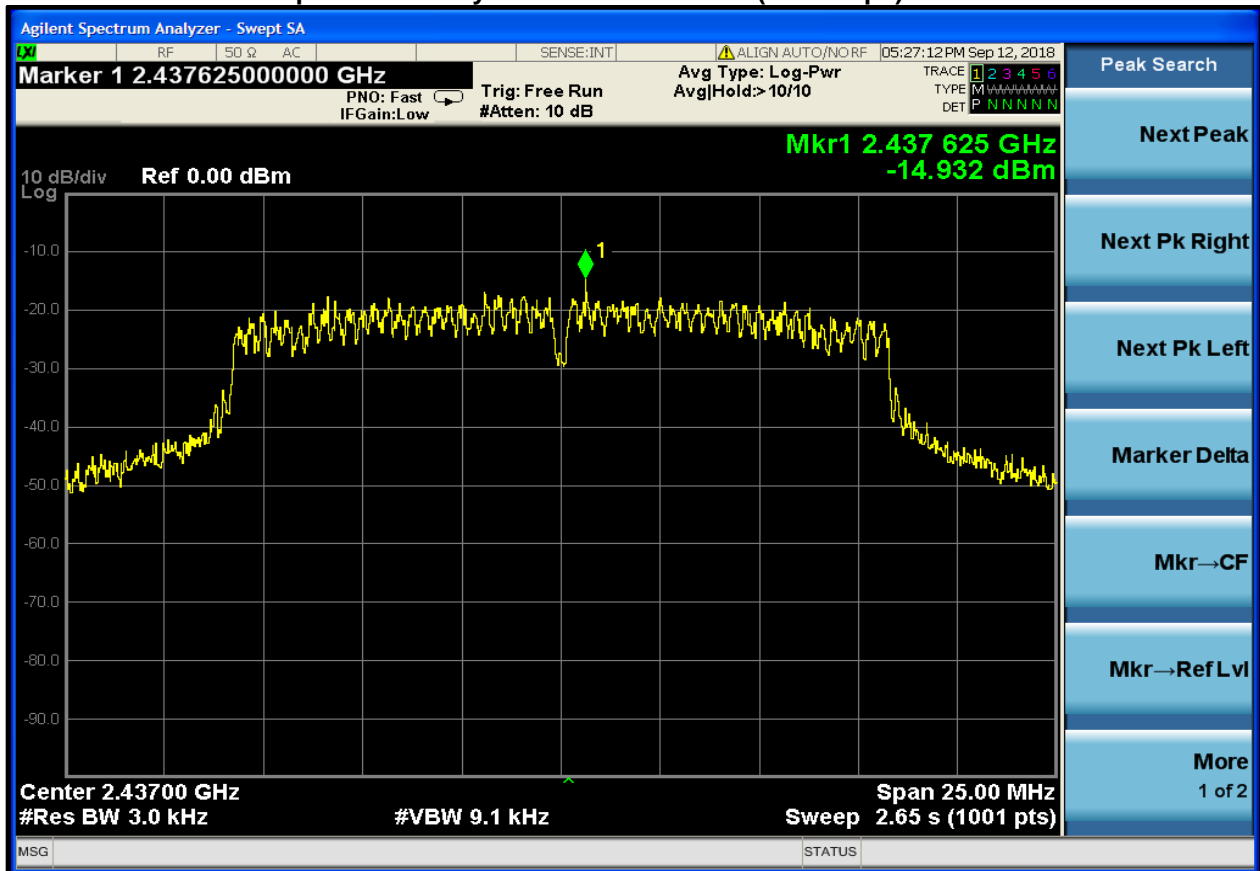

Plot 7-3: Power Spectral Density – 2462 MHz – 802.11 (11.0 Mbps)

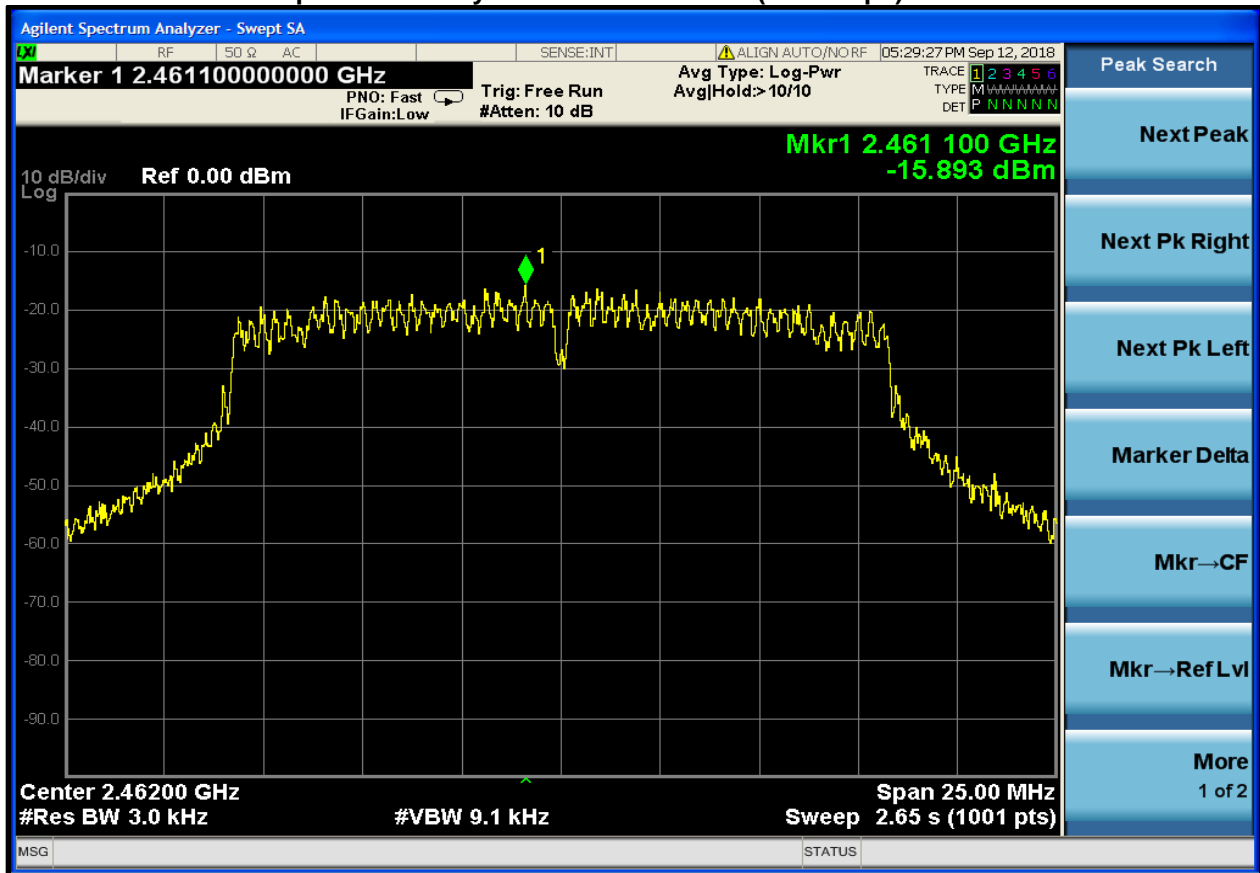

Measurement uncertainty: ± 0.5 dB. This measurement uncertainty is an expanded uncertainty for 95% confidence level received with a coverage factor $k=2$.

Results: Pass

Test Personnel:

Khue Do
 Test Engineer

[Handwritten Signature]
 Signature

September 12, 2018
 Date of Test

Rhein Tech Laboratories, Inc.
360 Herndon Parkway
Suite 1400
Herndon, VA 20170
<http://www.rheintech.com>

Client: Harris Corporation
Model #/HVIN: XZ-MPM1M
Standards: FCC 15.247 & ISED RSS-247
ID's: OWDTR-0161-E/3636B-0161
Report #: 2019062DTS

8 AC Conducted Emissions – FCC 15.207; RSS-Gen 8.8

Device is a mobile 13.6 VDC equipment. AC line conducted emissions measurements are not required.

9 Radiated Emissions – FCC 15.209; RSS-247 5.5; RSS-Gen 8.9, 8.10

9.1 Limits of Radiated Emissions Measurement

Frequency (MHz)	Field Strength ($\mu\text{V/m}$)	Measurement Distance (m)
0.009-0.490	2400/f (kHz)	300
0.490-1.705	2400/f (kHz)	30
1.705-30.0	30	30
30-88	100	3
88-216	150	3
216-960	200	3
Above 960	500	3

As shown in 15.35(b), for frequencies above 1000 MHz, the field strength limits are based on average detector, however, the peak field strength of any emission shall not exceed the maximum permitted average limits, specified above by more than 20 dB under any circumstances of modulation.

9.2 Radiated Emissions Measurement Test Procedure

Before final measurements of radiated emissions were made on the open-field three/ten meter range, the EUT was scanned indoors at one and three meter distances. This was done in order to determine its emissions spectrum signature. The physical arrangement of the test system and associated cabling was varied in order to determine the effect on the EUT's emissions in amplitude, direction and frequency. This process was repeated during final radiated emissions measurements on the open-field range, at each frequency, in order to ensure that maximum emission amplitudes were attained.

Final radiated emissions measurements were made on the three/ten-meter, open-field test site. The EUT was placed on a nonconductive turntable 0.8 meters above the ground plane. The spectrum was examined from 9 kHz to the 10th harmonic of the highest fundamental transmitter frequency (24.8 GHz).

At each frequency, the EUT was rotated 360°, and the antenna was raised and lowered from 1 to 4 meters in order to determine the emission's maximum level. Measurements were taken using both horizontal and vertical antenna polarizations. For frequencies between 30 and 1000 MHz, the spectrum analyzer's 6 dB bandwidth was set to 120 kHz, and the analyzer was operated in the CISPR quasi-peak detection mode. For emissions above 1000 MHz, emissions are measured using the average detector function with a minimum resolution bandwidth of 1 MHz. No video filter less than 10 times the resolution bandwidth was used. The highest emission amplitudes relative to the appropriate limit were measured and recorded in this report.

Table 9-1: Radiated Emissions Test Equipment

RTL Asset #	Manufacturer	Model	Part Type	Serial Number	Calibration Due Date
900772	EMCO	3161-02	Horn Antenna (2.0–4.0 GHz)	9804-1044	5/17/21
900321	EMCO	3161-03	Horn Antennas (4.0–8.2 GHz)	9508-1020	5/17/21
900323	EMCO	3160-7	Horn Antennas (8.2–12.4 GHz)	9605-1054	5/17/21
900356	EMCO	3160-08	Horn Antenna (12.4–18.0 GHz)	9607-1044	5/17/21
901218	EMCO	3160-09	Horn Antenna (18.0–26.5 GHz)	960281-003	5/17/21
900791	Chase	CBL6111B	Bilog Antenna (30–2000 MHz)	N/A	10/4/20
901581	Rohde & Schwarz	FSU	Spectrum Analyzer	1166.1660.50	4/26/21

9.3 Radiated Emissions Test Results

Note: EUT was programmed to TX with 1.0 Mbps rate for 802.11b, 54 Mbps for 802.11g, and 6.5 Mbps for 802.11a.

Table 9-2: Radiated Emissions Harmonics/Spurious – 2412 MHz, Peak Detector; 802.11b

Frequency (MHz)	Peak Analyzer (dBµV/m)	Site Correction Factor (dB/m)	Peak Corrected (dBµV/m)	Peak Limit (dBµV/m)	Peak Margin (dB)
4824.0	18.9	33.5	52.4	74.0	-21.6
12060.0	14.2	44.1	58.3	74.0	-15.7
14472.0	4.7	48.3	53.0	74.0	-21.0
19296.0	5.6	53.3	58.9	74.0	-15.1

Table 9-3: Radiated Emissions Harmonics/Spurious – 2412 MHz, Average Detector; 802.11b

Frequency (MHz)	Average Analyzer (dBµV/m)	Site Correction Factor (dB/m)	Average Corrected (dBµV/m)	Average Limit (dBµV/m)	Average Margin (dB)
4824.0	14.9	33.5	48.4	54.0	-5.6
12060.0	3.7	44.1	47.8	54.0	-6.2
14472.0	-4.8	48.3	43.5	54.0	-10.5
19296.0	-4.9	53.3	48.4	54.0	-5.6

Table 9-4: Radiated Emissions Harmonics/Spurious – 2437 MHz, Peak Detector; 802.11b

Frequency (MHz)	Peak Analyzer (dBµV/m)	Site Correction Factor (dB/m)	Peak Corrected (dBµV/m)	Peak Limit (dBµV/m)	Peak Margin (dB)
4874.0	18.0	33.5	51.5	74.0	-22.5
7311.0	13.6	35.8	49.4	74.0	-24.6
12185.0	15.2	44.1	59.3	74.0	-14.7
19496.0	5.2	53.6	58.8	74.0	-15.2

Table 9-5: Radiated Emissions Harmonics/Spurious – 2437 MHz, Average Detector; 802.11b

Frequency (MHz)	Average Analyzer (dBµV/m)	Site Correction Factor (dB/m)	Average Corrected (dBµV/m)	Average Limit (dBµV/m)	Average Margin (dB)
4874.0	13.5	33.5	47.0	54.0	-7.0
7311.0	3.2	35.8	39.0	54.0	-15.0
12185.0	4.4	44.1	48.5	54.0	-5.5
19496.0	-4.6	53.6	49.0	54.0	-5.0

Table 9-6: Radiated Emissions Harmonics/Spurious – 2462 MHz, Peak Detector; 802.11b

Frequency (MHz)	Peak Analyzer (dBµV/m)	Site Correction Factor (dB/m)	Peak Corrected (dBµV/m)	Peak Limit (dBµV/m)	Peak Margin (dB)
4924.0	20.1	33.6	53.7	74.0	-20.3
7386.0	13.9	35.8	49.7	74.0	-24.3
12310.0	14.1	44.3	58.4	74.0	-15.6
19696.0	5.5	53.6	59.1	74.0	-14.9
22158.0	6.3	55.4	61.7	74.0	-12.3

Table 9-7: Radiated Emissions Harmonics/Spurious – 2462 MHz, Average Detector; 802.11b

Frequency (MHz)	Average Analyzer (dBµV/m)	Site Correction Factor (dB/m)	Average Corrected (dBµV/m)	Average Limit (dBµV/m)	Average Margin (dB)
4924.0	15.8	33.6	49.4	54.0	-4.6
7386.0	3.1	35.8	38.9	54.0	-15.1
12310.0	3.3	44.3	47.6	54.0	-6.4
19696.0	-4.1	53.6	49.5	54.0	-4.5
22158.0	-4.2	55.4	51.2	54.0	-2.8

Table 9-8: Radiated Emissions Harmonics/Spurious – 2412 MHz, Peak Detector; 802.11g

Frequency (MHz)	Peak Analyzer (dBµV/m)	Site Correction Factor (dB/m)	Peak Corrected (dBµV/m)	Peak Limit (dBµV/m)	Peak Margin (dB)
4824.0	19.2	33.5	52.7	74.0	-21.3
12060.0	13.5	44.1	57.6	74.0	-16.4
14472.0	4.5	48.3	52.8	74.0	-21.2
19296.0	5.8	53.3	59.1	74.0	-14.9

Table 9-9: Radiated Emissions Harmonics/Spurious – 2412 MHz, Average Detector; 802.11g

Frequency (MHz)	Average Analyzer (dBµV/m)	Site Correction Factor (dB/m)	Average Corrected (dBµV/m)	Average Limit (dBµV/m)	Average Margin (dB)
4824.0	14.5	33.5	48.0	54.0	-6.0
12060.0	3.4	44.1	47.5	54.0	-6.5
14472.0	-5.4	48.3	42.9	54.0	-11.1
19296.0	-3.9	53.3	49.4	54.0	-4.6

Table 9-10: Radiated Emissions Harmonics/Spurious – 2437 MHz, Peak Detector; 802.11g

Frequency (MHz)	Peak Analyzer (dBµV/m)	Site Correction Factor (dB/m)	Peak Corrected (dBµV/m)	Peak Limit (dBµV/m)	Peak Margin (dB)
4874.0	18.2	33.5	51.7	74.0	-22.3
7311.0	13.1	35.8	48.9	74.0	-25.1
12185.0	14.1	44.1	58.2	74.0	-15.8
19496.0	5.6	53.6	59.2	74.0	-14.8

Table 9-11: Radiated Emissions Harmonics/Spurious – 2437 MHz, Average Detector; 802.11g

Frequency (MHz)	Average Analyzer (dBµV/m)	Site Correction Factor (dB/m)	Average Corrected (dBµV/m)	Average Limit (dBµV/m)	Average Margin (dB)
4874.0	13.6	33.5	47.1	54.0	-6.9
7311.0	2.9	35.8	38.7	54.0	-15.3
12185.0	4.0	44.1	48.1	54.0	-5.9
19496.0	-4.3	53.6	49.3	54.0	-4.7

Table 9-12: Radiated Emissions Harmonics/Spurious – 2462 MHz, Peak Detector; 802.11g

Frequency (MHz)	Peak Analyzer (dBµV/m)	Site Correction Factor (dB/m)	Peak Corrected (dBµV/m)	Peak Limit (dBµV/m)	Peak Margin (dB)
4924.0	16.8	33.6	50.4	74.0	-23.6
7386.0	13.4	35.8	49.2	74.0	-24.8
12310.0	13.4	44.3	57.7	74.0	-16.3
19696.0	5.5	53.6	59.1	74.0	-14.9
22158.0	5.7	55.4	61.1	74.0	-12.9

Table 9-13: Radiated Emissions Harmonics/Spurious – 2462 MHz, Average Detector; 802.11g

Frequency (MHz)	Average Analyzer (dBµV/m)	Site Correction Factor (dB/m)	Average Corrected (dBµV/m)	Average Limit (dBµV/m)	Average Margin (dB)
4924.0	11.2	33.6	44.8	54.0	-9.2
7386.0	3.0	35.8	38.8	54.0	-15.2
12310.0	3.0	44.3	47.3	54.0	-6.7
19696.0	-4.3	53.6	49.3	54.0	-4.7
22158.0	-4.0	55.4	51.4	54.0	-2.6

Table 9-14: Radiated Emissions Harmonics/Spurious – 2412 MHz, Peak Detector; 802.11n

Frequency (MHz)	Peak Analyzer (dBµV/m)	Site Correction Factor (dB/m)	Peak Corrected (dBµV/m)	Peak Limit (dBµV/m)	Peak Margin (dB)
4824.0	20.8	33.5	54.3	74.0	-19.7
12060.0	14.8	44.1	58.9	74.0	-15.1
14472.0	14.7	48.3	63.0	74.0	-11.0
19296.0	5.4	53.3	58.7	74.0	-15.3

Table 9-15: Radiated Emissions Harmonics/Spurious – 2412 MHz, Average Detector; 802.11n

Frequency (MHz)	Average Analyzer (dBµV/m)	Site Correction Factor (dB/m)	Average Corrected (dBµV/m)	Average Limit (dBµV/m)	Average Margin (dB)
4824.0	11.6	33.5	45.1	54.0	-8.9
12060.0	3.9	44.1	48.0	54.0	-6.0
14472.0	4.6	48.3	52.9	54.0	-1.1
19296.0	-4.4	53.3	48.9	54.0	-5.1

Table 9-16: Radiated Emissions Harmonics/Spurious – 2437 MHz, Peak Detector; 802.11n

Frequency (MHz)	Peak Analyzer (dBµV/m)	Site Correction Factor (dB/m)	Peak Corrected (dBµV/m)	Peak Limit (dBµV/m)	Peak Margin (dB)
4874.0	21.4	33.5	54.9	74.0	-19.1
7311.0	13.6	35.8	49.4	74.0	-24.6
12185.0	15.2	44.1	59.3	74.0	-14.7
19496.0	5.2	53.6	58.8	74.0	-15.2

Table 9-17: Radiated Emissions Harmonics/Spurious – 2437 MHz, Average Detector; 802.11n

Frequency (MHz)	Average Analyzer (dBµV/m)	Site Correction Factor (dB/m)	Average Corrected (dBµV/m)	Average Limit (dBµV/m)	Average Margin (dB)
4874.0	11.6	33.5	45.1	54.0	-8.9
7311.0	3.2	35.8	39.0	54.0	-15.0
12185.0	4.4	44.1	48.5	54.0	-5.5
19496.0	-4.6	53.6	49.0	54.0	-5.0

Table 9-18: Radiated Emissions Harmonics/Spurious – 2462 MHz, Peak Detector; 802.11n

Frequency (MHz)	Peak Analyzer (dBµV/m)	Site Correction Factor (dB/m)	Peak Corrected (dBµV/m)	Peak Limit (dBµV/m)	Peak Margin (dB)
4924.0	16.6	33.6	50.2	74.0	-23.8
7386.0	14.1	35.8	49.9	74.0	-24.1
12310.0	14.5	44.3	58.8	74.0	-15.2
19696.0	6.4	53.6	60.0	74.0	-14.0
22158.0	6.6	55.4	62.0	74.0	-12.0

Table 9-19: Radiated Emissions Harmonics/Spurious – 2462 MHz, Average Detector; 802.11n

Frequency (MHz)	Average Analyzer (dBµV/m)	Site Correction Factor (dB/m)	Average Corrected (dBµV/m)	Average Limit (dBµV/m)	Average Margin (dB)
4924.0	7.8	33.6	41.4	54.0	-12.6
7386.0	3.4	35.8	39.2	54.0	-14.8
12310.0	5.2	44.3	49.5	54.0	-4.5
19696.0	-3.9	53.6	49.7	54.0	-4.3
22158.0	-3.9	55.4	51.5	54.0	-2.5

Table 9-20: Unintentional Emissions Test Data

Temperature: 88.0°F Humidity: 34%										
Emission Frequency (MHz)	Test Detector	Antenna Polarity (H/V)	Turntable Azimuth (°)	Antenna Height (m)	Analyzer Reading (dBµV)	Site Correction Factor (dB/m)	Emission Level (dBµV/m)	Limit (dBµV/m)	Margin (dB)	Pass/Fail
57.000	QP	V	180	1	54.8	-28.8	26.0	40.0	-14.0	Pass
83.330	QP	V	180	1	49.6	-28.3	21.3	40.0	-18.7	Pass
120.000	QP	V	180	1	63.3	-26.2	37.1	43.5	-6.4	Pass
125.000	QP	V	180	1	51.6	-26.7	24.9	43.5	-18.6	Pass
175.000	QP	V	180	1	54.7	-25.1	29.6	43.5	-13.9	Pass
225.000	QP	V	180	1	39.1	-23.2	15.8	46.0	-30.2	Pass
250.000	QP	V	180	1	45.1	-21.8	23.3	46.0	-22.7	Pass
275.000	QP	V	180	1	39.5	-20.8	18.8	46.0	-27.2	Pass
347.764	QP	V	180	1	37.6	-18.4	19.1	46.0	-26.9	Pass
350.000	QP	H	180	1	40.9	-18.3	22.6	46.0	-23.4	Pass
359.761	QP	H	180	1	27.7	-18.1	9.6	46.0	-36.4	Pass
371.757	QP	H	180	1	32.1	-18.6	13.5	46.0	-32.5	Pass
383.763	QP	V	180	1	34.8	-18.3	16.5	46.0	-29.5	Pass
395.750	QP	V	180	1	43.6	-17.0	26.6	46.0	-19.4	Pass
400.000	QP	H	180	1	44.8	-16.9	27.9	46.0	-18.1	Pass
407.730	QP	V	180	1	31.6	-16.4	15.2	46.0	-30.8	Pass
419.743	QP	H	180	1	28.6	-16.6	12.0	46.0	-34.0	Pass
431.740	QP	H	180	1	28.5	-17.1	11.4	46.0	-34.6	Pass
443.736	QP	H	180	1	29.2	-16.8	12.3	46.0	-33.7	Pass
455.733	QP	H	180	1	26.6	-16.2	10.4	46.0	-35.6	Pass
467.729	QP	H	180	1	27.7	-15.7	12.0	46.0	-34.0	Pass
491.722	QP	H	180	1	27.3	-15.5	11.9	46.0	-34.1	Pass
503.719	QP	H	180	1	26.5	-15.2	11.3	46.0	-34.7	Pass
515.715	QP	H	180	1	38.4	-14.5	23.9	46.0	-22.1	Pass
527.712	QP	H	180	1	37.9	-13.4	24.5	46.0	-21.5	Pass
539.708	QP	H	180	1	39.6	-13.2	26.5	46.0	-19.5	Pass
551.705	QP	H	180	1	27.0	-13.6	13.4	46.0	-32.6	Pass
563.701	QP	H	180	1	32.5	-14.2	18.3	46.0	-27.7	Pass
611.613	QP	H	180	1	32.5	-12.2	20.3	46.0	-25.7	Pass
623.609	QP	H	180	1	39.1	-12.1	27.0	46.0	-19.0	Pass

Measurement uncertainty: ±4.7 dB. This measurement uncertainty is an expanded uncertainty for 95% confidence level received with a coverage factor k=2.

Results: Pass

Test Personnel:

Dan Baltzell
 Test Engineer



Signature

September 3/15, 2019
 Dates of Test

Rhein Tech Laboratories, Inc.
360 Herndon Parkway
Suite 1400
Herndon, VA 20170
<http://www.rheintech.com>

Client: Harris Corporation
Model #/HVIN: XZ-MPM1M
Standards: FCC 15.247 & ISED RSS-247
ID's: OWDTR-0161-E/3636B-0161
Report #: 2019062DTS

10 Conclusion

The data in this DTS measurement report shows that the EUT as tested, Harris Corporation XL-200M Multi-Band Mobile, VL/V/H/7/8/9, Model #/HVIN XZ-MPM1M, FCC ID: OWDTR-0161-E, IC: 3636B-0161, complies with the applicable requirements of FCC Parts 2 and 15 and ISED RSS-247 and RSS-Gen.