



Engineering Solutions & Electromagnetic Compatibility Services

**Certification Application Report
FCC Part 15.247 & ISED RSS-247**

| | | | |
|--|--|--|----------------------------|
| Test Lab: Rhein Tech Laboratories, Inc. Phone: 703-689 0368 360 Herndon Parkway www.rheintech.com Suite 1400 Herndon, VA 20170 E-Mail: atcbinfo@rheintech.com | | Applicant: Harris Corporation 221 Jefferson Ridge Parkway Lynchburg, VA 24501 USA | |
| FCC ID/ IC | OWDTR-0161-E/ 3636B-0161 | Test Report Date | October 3, 2019 |
| Platform | N/A | RTL Work Order # | 2019062 |
| Model / Model #/HVIN | XL-200M / XZ-MPM1M | RTL Quote Number | QRTL19-062A |
| American National Standard Institute | ANSI C63.10-2013: American National Standard of Procedures for Compliance Testing of Unlicensed Wireless Devices | | |
| FCC Classification | DSS – Part 15 Spread Spectrum Transmitter | | |
| FCC Rule Part(s) | FCC Rules Part 15.247: Operation within the bands 902-928 MHz, 2400-2483.5 MHz and 5725-5850 MHz (10-01-18) | | |
| ISED Standards | RSS-247 Issue 2: Digital Transmission Systems (DTSs), Frequency Hopping Systems (FHSs) and Licence-Exempt Local Area Network (LE-LAN) Devices RSS-Gen Issue 5: General Requirements for Compliance of Radio Apparatus | | |
| Frequency Range (MHz) | Output Power (mW) Peak Conducted | Frequency Tolerance | Emission Designator |
| 2402-2480 | 13.5 | N/A | 874KFXD |
| 2402-2480 | 6.7 | N/A | 970KFXD |
| 2402-2480 | 7.3 | N/A | 950KFXD |

I, the undersigned, hereby declare that the equipment tested and referenced in this report conforms to the identified standard(s) as described in this test report. No modifications were made to the equipment during testing in order to achieve compliance with these standards. Furthermore, there was no deviation from, additions to, or exclusions from, the applicable parts of FCC Part 2, FCC Part 15, ANSI C63.10, and ISED RSS-247 and RSS-Gen.

Signature: 

Date: October 3, 2019

Typed/Printed Name: Desmond A. Fraser

Position: President

These tests are accredited and meet the requirements of ISO/IEC 17025 as verified by ANAB. Refer to certificate and scope of accreditation AT-1445. This report replaces R0.0.

This report may not be reproduced, except in full, without the written approval of Rhein Tech Laboratories, Inc. and Harris Corporation. The test results relate only to the item(s) tested.

Table of Contents

| | | |
|------|--|----|
| 1 | General Information | 5 |
| 1.1 | Scope | 5 |
| 1.2 | Description of EUT | 5 |
| 1.3 | Test Facility | 5 |
| 1.4 | Related Submittal(s)/Grant(s) | 5 |
| 1.5 | Modifications | 5 |
| 2 | Test Information | 6 |
| 2.1 | Description of Test Modes | 6 |
| 2.2 | Exercising the EUT | 6 |
| 2.3 | Test Result Summary..... | 6 |
| 2.4 | Tested System Details | 7 |
| 2.5 | Configuration of Tested System..... | 8 |
| 3 | Peak Output Power – FCC 15.247(b)(1); RSS-247 5.4(b), RSS-Gen 6.12..... | 9 |
| 3.1 | Power Output Test Procedure..... | 9 |
| 3.2 | Power Output Test Results | 9 |
| 4 | Control Head Compliance with the Band Edge – FCC 15.247(d); RSS-247 5.5 | 10 |
| 4.1 | Band Edge Test Procedure..... | 10 |
| 4.2 | Restricted Band Edge Test Results | 10 |
| 4.3 | Band Edge Plots | 11 |
| 5 | Antenna Conducted Spurious Emissions – FCC 15.247(d); RSS-247 5.5, RSS-Gen 6.13..... | 15 |
| 5.1 | Antenna Conducted Spurious Emissions Test Procedures..... | 15 |
| 5.2 | Antenna Conducted Spurious Emissions Test Results | 15 |
| 6 | Bandwidths – FCC 15.247(a)(1); RSS-247 5.1(a); RSS-Gen 6.7 | 16 |
| 6.1 | Bandwidth Test Procedure..... | 16 |
| 6.2 | Modulated Bandwidth Test Results | 16 |
| 6.3 | Bandwidth Plots | 17 |
| 7 | Carrier Frequency Separation – FCC 15.247(a)(1); RSS-247 5.1(b)..... | 23 |
| 7.1 | Carrier Frequency Separation Test Procedure | 23 |
| 7.2 | Carrier Frequency Separation Test Data | 23 |
| 8 | Hopping Characteristics – FCC 15.247(a)(1)(iii); RSS-247 5.1(d) | 24 |
| 8.1 | Hopping Characteristics Test Procedure | 24 |
| 8.2 | Average Time of Occupancy – FCC 15.247(a)(1)(iii); RSS-247 5.1(d) | 25 |
| 9 | AC Conducted Emissions – FCC 15.207; RSS-Gen 8.8..... | 27 |
| 10 | Radiated Emissions – FCC 15.209; RSS-247 5.5; RSS-Gen 8.9, 8.10 | 28 |
| 10.1 | Limits of Radiated Emissions Measurement..... | 28 |
| 10.2 | Radiated Emissions Measurement Test Procedure..... | 28 |
| 10.3 | Radiated Emissions Test Results | 29 |
| 11 | Conclusion | 36 |

Figure Index

Figure 2-1: Configuration of System Under Test.....8

Table Index

Table 2-1: Test Frequencies.....6
 Table 2-2: Test Result Summary – FCC Part 15, Subpart C (Section 15.247); RSS-247, RSS-Gen6
 Table 2-3: Equipment Under Test (EUT).....7
 Table 2-4: Support Equipment.....7
 Table 2-5: Auxiliary Equipment7
 Table 3-1: Power Output Test Equipment.....9
 Table 3-2: Power Output Test Data – GFSK.....9
 Table 4-1: Band Edge Test Equipment10
 Table 4-2: Lower Band Edge Average – GFSK11
 Table 4-3: Lower Band Edge Peak – GFSK.....12
 Table 4-4: Upper Band Edge Average – GFSK13
 Table 4-5: Upper Band Edge Peak – GFSK.....14
 Table 5-1: Antenna Conducted Spurious Emissions Test Equipment15
 Table 6-1: Bandwidth Test Equipment16
 Table 6-2: Modulated Bandwidth Test Data – GFSK16
 Table 7-1: Carrier Frequency Separation Test Equipment23
 Table 8-1: Hopping Characteristics Test Equipment.....24
 Table 8-2: Average Time of Occupancy Test Equipment25
 Table 10-1: Radiated Emissions Test Equipment29
 Table 10-2: Radiated Emissions Harmonics/Spurious – GFSK - 2402 MHz, Peak Detector29
 Table 10-3: Radiated Emissions Harmonics/Spurious – GFSK - 2402 MHz, Average Detector29
 Table 10-4: Radiated Emissions Harmonics/Spurious – GFSK - 2440 MHz, Peak Detector30
 Table 10-5: Radiated Emissions Harmonics/Spurious – GFSK - 2440 MHz, Average Detector30
 Table 10-6: Radiated Emissions Harmonics/Spurious – GFSK - 2480 MHz, Peak Detector30
 Table 10-7: Radiated Emissions Harmonics/Spurious – GFSK - 2480 MHz, Average Detector31
 Table 10-8: Radiated Emissions Harmonics/Spurious – 2-EDR - 2402 MHz, Peak Detector31
 Table 10-9: Radiated Emissions Harmonics/Spurious – 2-EDR - 2402 MHz, Average Detector31
 Table 10-10: Radiated Emissions Harmonics/Spurious – 2-EDR - 2440 MHz, Peak Detector31
 Table 10-11: Radiated Emissions Harmonics/Spurious – 2-EDR - 2440 MHz, Average Detector32
 Table 10-12: Radiated Emissions Harmonics/Spurious – 2-EDR - 2480 MHz, Peak Detector32
 Table 10-13: Radiated Emissions Harmonics/Spurious – 2-EDR - 2480 MHz, Average Detector32
 Table 10-14: Radiated Emissions Harmonics/Spurious – 3-EDR - 2402 MHz, Peak Detector32
 Table 10-15: Radiated Emissions Harmonics/Spurious – 3-EDR - 2402 MHz, Average Detector33
 Table 10-16: Radiated Emissions Harmonics/Spurious – 3-EDR - 2440 MHz, Peak Detector33
 Table 10-17: Radiated Emissions Harmonics/Spurious – 3-EDR - 2440 MHz, Average Detector33
 Table 10-18: Radiated Emissions Harmonics/Spurious – 3-EDR - 2480 MHz, Peak Detector33
 Table 10-19: Radiated Emissions Harmonics/Spurious – 3-EDR - 2480 MHz, Average Detector34
 Table 10-32: Unintentional Emissions Test Data35

Plot Index

| | | |
|-----------|---|----|
| Plot 4-1: | Lower Band Edge – Average – GFSK | 11 |
| Plot 4-2: | Lower Band Edge – Peak – GFSK..... | 12 |
| Plot 4-3: | Upper Band Edge – Average – GFSK | 13 |
| Plot 4-4: | Upper Band Edge – Peak – GFSK..... | 14 |
| Plot 6-1: | 20 dB Bandwidth – 2402 MHz – GFSK..... | 17 |
| Plot 6-2: | 20 dB Bandwidth – 2440 MHz – GFSK..... | 18 |
| Plot 6-3: | 20 dB Bandwidth – 2480 MHz – GFSK..... | 19 |
| Plot 6-4: | 99% Bandwidth – 2402 MHz – GFSK..... | 20 |
| Plot 6-5: | 99% Bandwidth – 2440 MHz – GFSK..... | 21 |
| Plot 6-6: | 99% Bandwidth – 2480 MHz – GFSK..... | 22 |
| Plot 7-1: | Carrier Frequency Separation..... | 23 |
| Plot 8-1: | Number of Hopping Frequencies | 24 |
| Plot 8-2: | Time of Occupancy (Dwell Time)..... | 25 |
| Plot 8-3: | Time of Occupancy (Dwell Time 31.6 Second Sweep)..... | 26 |

Appendix Index

| | | |
|-------------|------------------------|----|
| Appendix A: | Test Photographs | 37 |
|-------------|------------------------|----|

Photograph Index

| | | |
|---------------|---|----|
| Photograph 1: | Radiated Emissions Testing – Front View (Above 1 GHz) | 37 |
| Photograph 2: | Radiated Emissions Testing – Back View (Above 1 GHz)..... | 38 |
| Photograph 3: | Radiated Emissions Testing – Front View (Below 1 GHz)..... | 39 |
| Photograph 4: | Radiated Emissions Testing – Back View (Below 1 GHz) | 40 |

1 General Information

1.1 Scope

Applicable Standards

- FCC Part 15.247: Frequency Hopping, Direct Spread Spectrum and Hybrid Systems that are in operation within the bands of 902-928 MHz, 2400-2483.5 MHz and 5725-5850 MHz
- ISED RSS-247: Digital Transmission Systems (DTSS), Frequency Hopping Systems (FHSs) and License-Exempt Local Area Network (LE-LAN) Devices
- ISED RSS-Gen Issue 5: General Requirements for Compliance of Radio Apparatus

1.2 Description of EUT

| | |
|-----------------------------|--------------------|
| Equipment Under Test | Mobile Radio |
| Model / Model # | XL-200M / XZ-MPM1M |
| Power Supply | 13.6 VDC |
| Modulation Type | FHSS |
| Frequency Range | 2402-2480 MHz |

1.3 Test Facility

The open area test site and conducted measurement facility used to collect the radiated data is located at 360 Herndon Parkway, Suite 1400, Herndon, Virginia 20170. This site has been fully described in a report and approved by the Federal Communications Commission to perform AC line conducted and radiated emissions testing (ANSI C63.10-2013).

1.4 Related Submittal(s)/Grant(s)

This is an original certification application for Harris Corporation Model XL-200M Multi-band Mobile, VL/V/U/7/8/9, Model #/HVIN XZ-MPM1M, FCC ID: OWDTR-0161-E, IC: 3636B-0161.

1.5 Modifications

No modifications were required for compliance.

2 Test Information

2.1 Description of Test Modes

In accordance with FCC 15.31(m), and because the EUT utilizes an operating band greater than 10 MHz, the following frequencies were tested:

Table 2-1: Test Frequencies

| Channel (#) | FHSS Frequency (MHz) |
|-------------|----------------------|
| 0 | 2402 |
| 39 | 2440 |
| 78 | 2480 |

2.2 Exercising the EUT

The EUT was tested in all three orthogonal planes in order to determine worst-case emissions. The EUT was provided with software to continuously transmit during testing. The carrier was also checked to verify that information was being transmitted, and all modes were investigated and the worst-case mode was used for final testing. There were no deviations from the test standard(s) and/or methods. The test results reported relate only to the item tested.

2.3 Test Result Summary

Table 2-2: Test Result Summary – FCC Part 15, Subpart C (Section 15.247); RSS-247, RSS-Gen

| FCC | ISED | Test | Result |
|-----------------------|--------------------------------|--------------------------------------|--------|
| FCC 15.207 | RSS-Gen 8.8 | AC Conducted Emissions | N/A |
| FCC 15.209 | RSS-247 5.5; RSS-Gen 8.9, 8.10 | Radiated Emissions | Pass |
| FCC 15.247(a)(1) | RSS-247 5.1(a) | 20 dB Bandwidth | Pass |
| FCC 15.247(a)(1) | RSS-247 5.1(b) | Carrier Frequency Separation | Pass |
| FCC 15.247(a)(1)(iii) | RSS-247 5.1(d) | Hopping Characteristics | Pass |
| FCC 15.247(a)(1)(iii) | RSS-247 5.1(d) | Average Time of Occupancy | Pass |
| FCC 15.247(b)(1) | RSS-247 5.4(b); RSS-Gen 6.12 | Maximum Peak Power Output | Pass |
| FCC 15.247(d) | RSS-247 5.5; RSS-Gen 6.13 | Antenna Conducted Spurious Emissions | Pass |
| FCC 15.247(d) | RSS-247 5.5 | Band Edge Measurement | Pass |
| N/A | RSS-Gen 6.7 | 99% Bandwidth | Pass |

2.4 Tested System Details

The test samples were received on September 4, 2018. The FCC identifiers for all applicable equipment, plus descriptions of all cables used in the tested system, are identified in the following tables.

Table 2-3: Equipment Under Test (EUT)

| Part | Manufacturer | Model/ HVIN | Serial Number | FCC ID | RTL Bar Code |
|---|-----------------------|--------------------------------------|------------------|--------------|--------------------|
| Vehicular Communication Hub (VCH) | Harris Corporation | XL-200M/ XZ-MPM1M | 048 | OWDTR-0161-E | 23081 |
| Control Head | Harris Corporation | XL-CH Mobile Control Head/ N/A | 085 | OWDTR-0161-E | 23080 |

Table 2-4: Support Equipment

| Part | Manufacturer | Model | PN/SN | FCC ID | RTL Bar Code |
|--------|--------------|-------|-----------------|--------|--------------------|
| Laptop | ASUS | N550J | F2N0CY33003067G | N/A | N/A |

Table 2-5: Auxiliary Equipment

| Part | Manufacturer | Model | PN/SN | FCC ID | RTL Bar Code |
|-----------------------------------|--------------|---------------------|--------------------|--------|--------------------|
| USB Mobile Mic | N/A | USB Mobile Mic | 14050-6010-01/V22e | N/A | 22756 |
| Remote Speaker | N/A | Remote Speaker | 14050-6100-01 | N/A | N/A |
| Analog Deskmic | N/A | Analog Deskmic | MC-014121-003 | N/A | N/A |
| CH Mounting Kit | N/A | CH Mounting Kit | 14050-6210-01 | N/A | N/A |
| VCH Mounting Kit | N/A | VCH Mounting Kit | 14050-6200-01 | N/A | N/A |
| Ethernet Cable, overmold, 45cm | N/A | N/A | 14050-6300-01 | N/A | N/A |
| Ethernet Cable, overmold, 9m | N/A | N/A | 14050-6300-02 | N/A | N/A |
| DC power cables (CH) | N/A | N/A | CA-012616-001 | N/A | N/A |
| DC power cables (VCH) | N/A | N/A | CA-012365-001 | N/A | N/A |

2.5 Configuration of Tested System

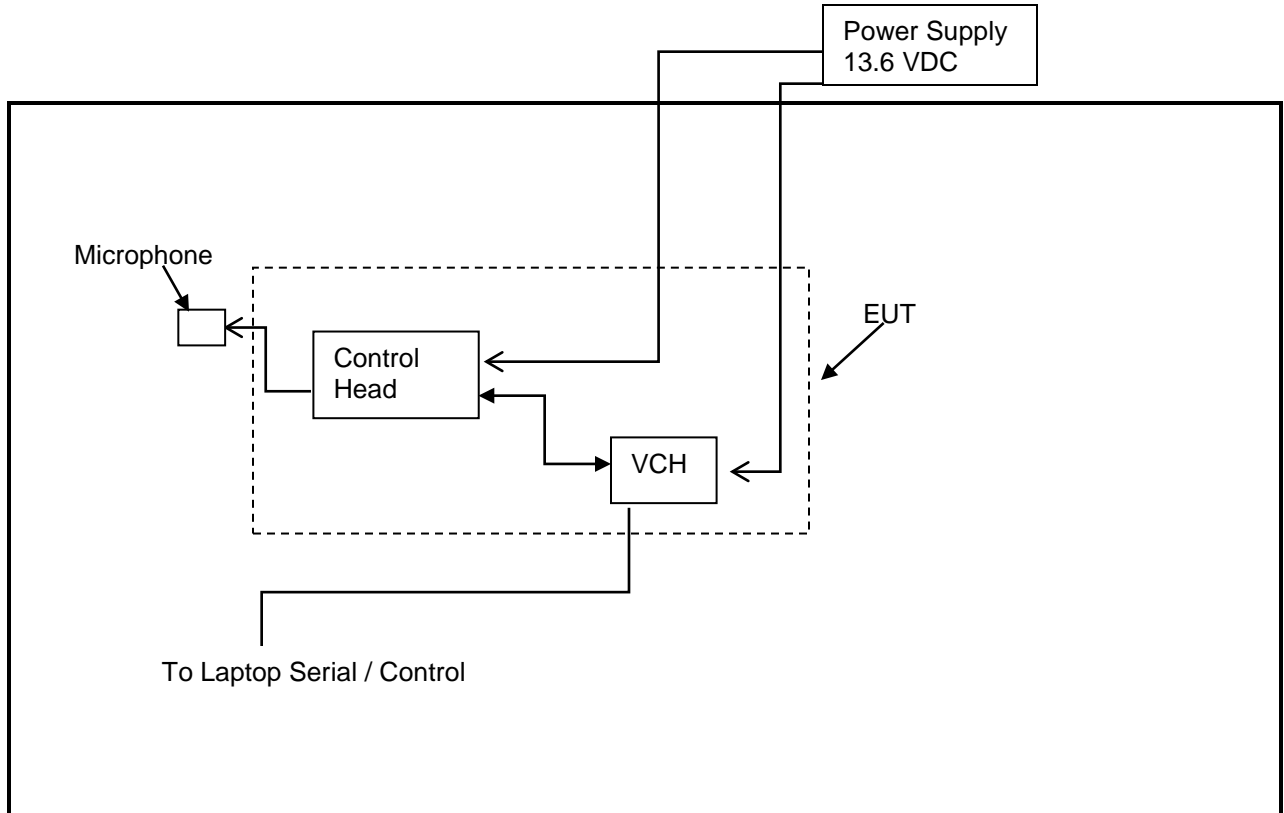

Figure 2-1: Configuration of System Under Test

3 Peak Output Power – FCC 15.247(b)(1); RSS-247 5.4(b), RSS-Gen 6.12

3.1 Power Output Test Procedure

A conducted power measurement of the EUT was taken using an Agilent Analyzer. The following settings were used:

- 1) Span: Approximately five times the 20 dB bandwidth, centered on a hopping channel (5 MHz used)
- 2) RBW >20 dB bandwidth of the emission being measured (2 MHz used)
- 3) VBW ≥RBW (3 MHz used)
- 4) Sweep: Auto
- 5) Detector function: Peak
- 6) Trace: Max hold. The trace was allowed to stabilize, and the marker-to-peak function was used to set the marker to the peak of the emission.

Table 3-1: Power Output Test Equipment

| RTL Asset # | Manufacturer | Model | Part Type | Serial Number | Calibration Due Date |
|-------------|----------------------|--------|--------------------------------------|---------------|----------------------|
| 901583 | Agilent Technologies | N9010A | EXA Signal Analyzer (10 Hz-26.5 GHz) | MY51250846 | 2/6/20 |

3.2 Power Output Test Results

Table 3-2: Power Output Test Data – GFSK

| Channel (#) | Frequency (MHz) | Conducted Peak Power (dBm) | Limit (dBm) | Margin (dB) |
|-------------|-----------------|----------------------------|-------------|-------------|
| 1 | 2402 | 11.3 | 21.0 | -9.7 |
| 6 | 2440 | 11.1 | 21.0 | -9.9 |
| 11 | 2480 | 11.2 | 21.0 | -9.8 |

Note: EUT was programmed to TX with GFSK modulation, PN15 test pattern and 7 dBm power level for all three test frequencies.

Highest conducted peak power measured: 11.3 dBm ≈ 13.5 mW

$$P(\text{Watts}) = 10^{(\text{dBm} / 10)} / 1000$$

Measurement uncertainty: ±0.5 dB. This measurement uncertainty is an expanded uncertainty for 95% confidence level received with a coverage factor k=2.

Results: Pass

Test Personnel:

Khue Do
 Test Engineer

 Signature

September 7, 2018
 Date of Test

4 Control Head Compliance with the Band Edge – FCC 15.247(d); RSS-247 5.5

4.1 Band Edge Test Procedure

The transmitter output was connected to the spectrum analyzer. Peak and average detector conducted plots were taken with a suitable span to encompass the peak of the fundamental, and traces to stop hopping and non-hopping modes. The measurement was performed from the highest peak in the restricted band (within 2 MHz), and the result was compared to the restricted band limit (54 dBμV/m). An offset was used to reference the fundamental power to a radiated field strength measurement.

Table 4-1: Band Edge Test Equipment

| RTL Asset # | Manufacturer | Model | Part Type | Serial Number | Calibration Due Date |
|-------------|----------------------|--------|--------------------------------------|---------------|----------------------|
| 901583 | Agilent Technologies | N9010A | EXA Signal Analyzer (10 Hz-26.5 GHz) | MY51250846 | 2/6/20 |

4.2 Restricted Band Edge Test Results

Note: EUT was programmed to TX with GFSK modulation, PN15 test pattern and 7 dBm power level for all three test frequencies.

Conversion of dBm to dBμV/m at 3 m.

$$\text{dB}\mu\text{V}/\text{m} = \text{dBm} + 104.7 - (20 * \text{LOG}(3\text{m})) = \text{dBm} + 95.2$$

4.3 Band Edge Plots

Plot 4-1: Lower Band Edge – Average – GFSK

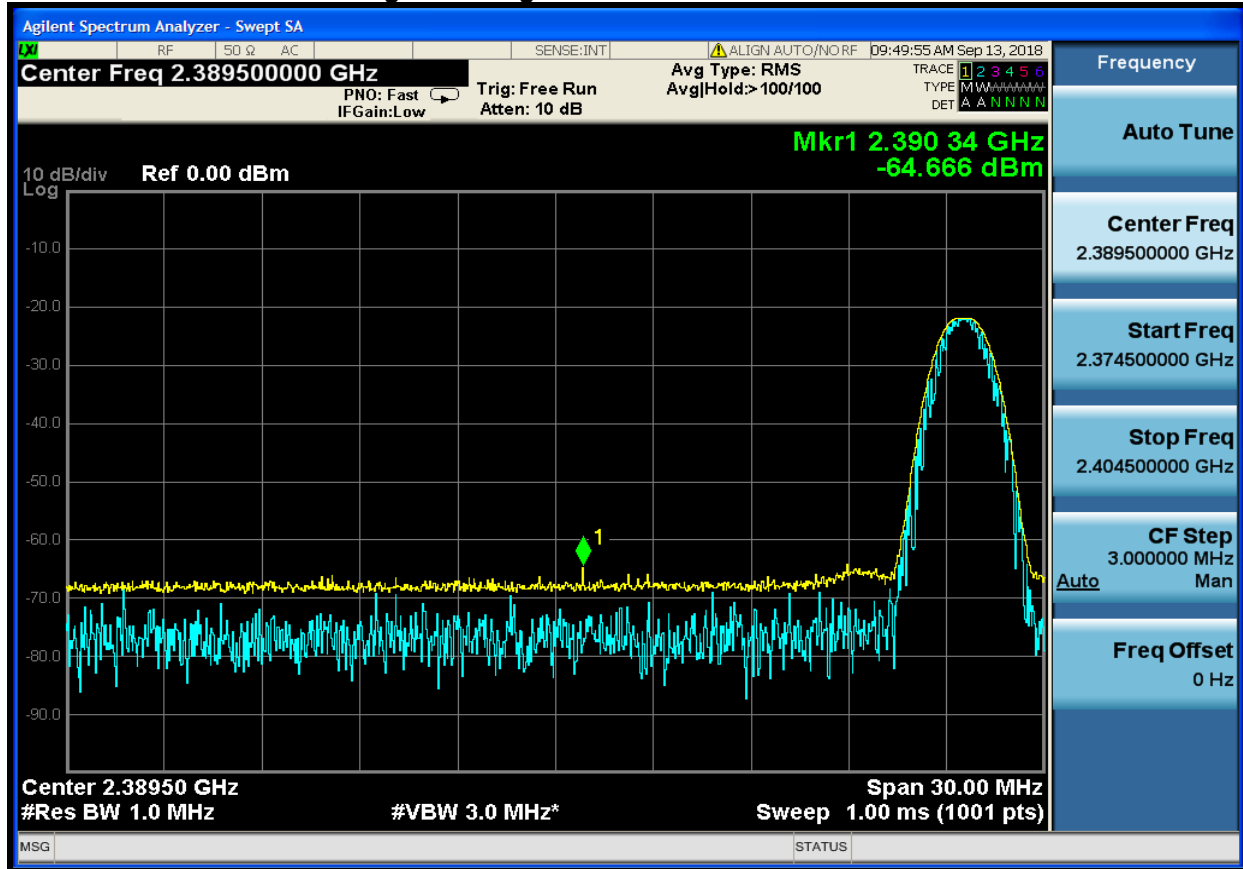

Table 4-2: Lower Band Edge Average – GFSK

| Frequency (MHz) | Measured Average Level (dBm) | Field Strength Conversion (dB μ V/m) | Average Limit (dB μ V/m) | Margin (dB) |
|-----------------|------------------------------|--|------------------------------|-------------|
| 2390.34 | -64.7 | 30.5 | 54.0 | -23.5 |

Plot 4-2: Lower Band Edge – Peak – GFSK

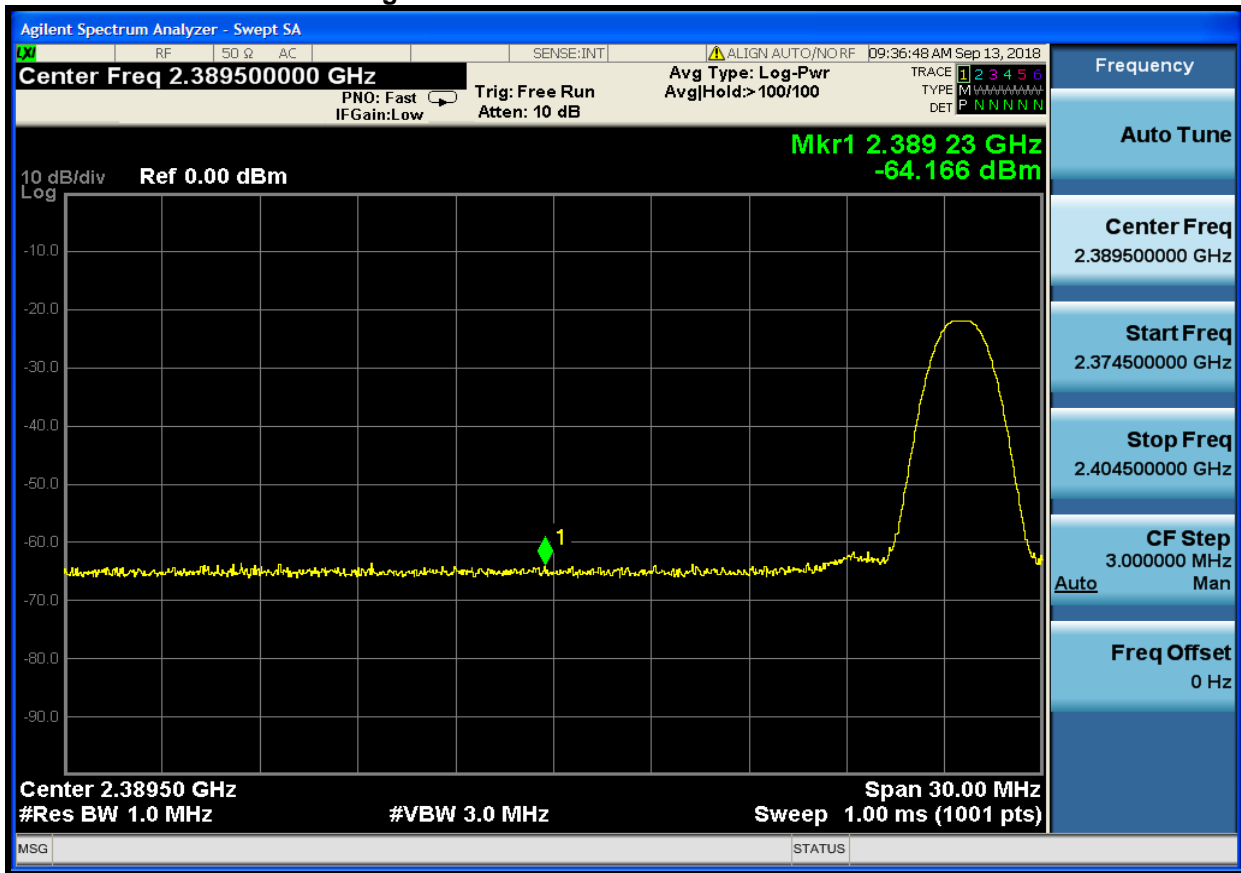

Table 4-3: Lower Band Edge Peak – GFSK

| Frequency (MHz) | Measured Peak Level (dBm) | Field Strength Conversion (dB μ V/m) | Peak Limit (dB μ V/m) | Margin (dB) |
|-----------------|---------------------------|--|---------------------------|-------------|
| 2389.23 | -64.2 | 31.0 | 74.0 | -43.0 |

Plot 4-3: Upper Band Edge – Average – GFSK

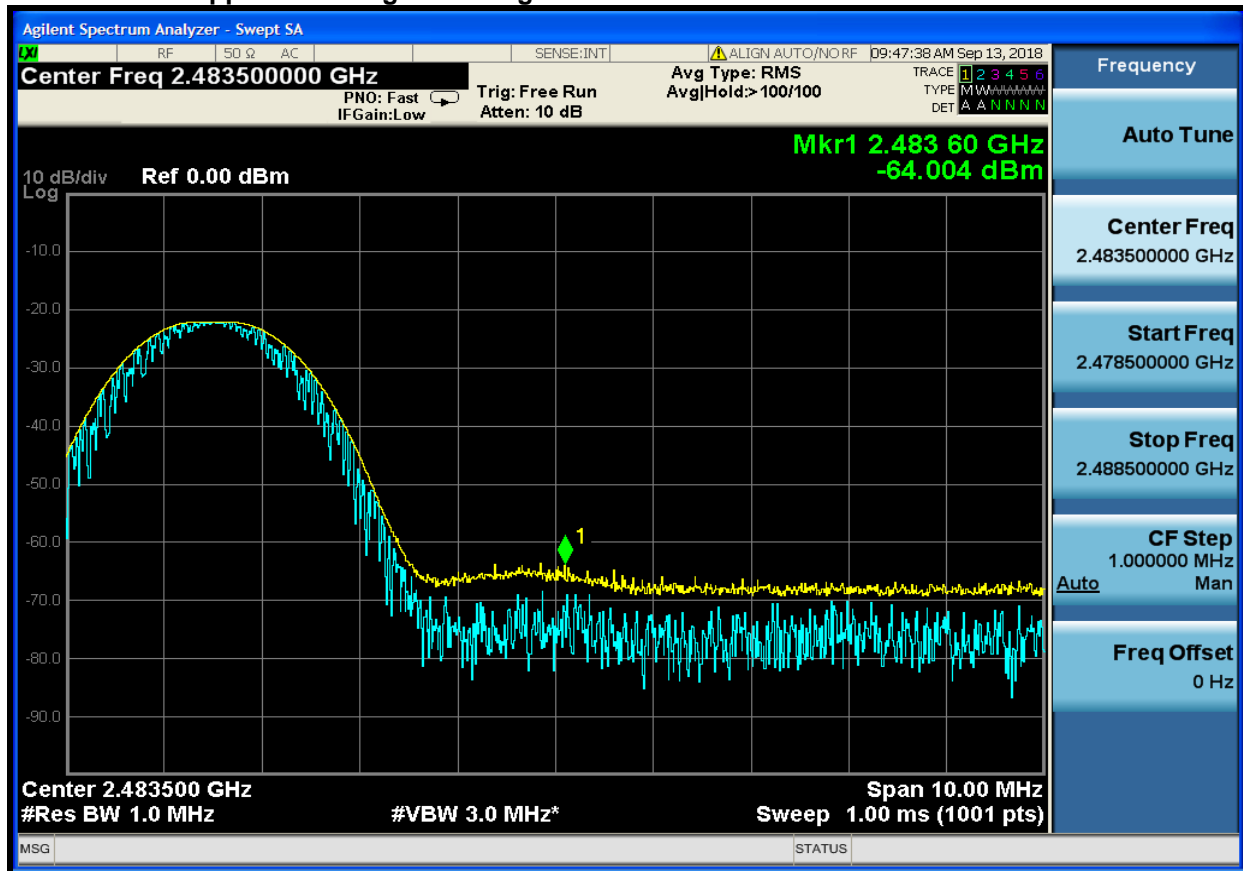

Table 4-4: Upper Band Edge Average – GFSK

| Frequency (MHz) | Measured Average Level (dBm) | Field Strength Conversion (dB μ V/m) | Average Limit (dB μ V/m) | Margin (dB) |
|-----------------|------------------------------|--|------------------------------|-------------|
| 2483.60 | -64.0 | 31.2 | 54.0 | -22.8 |

Plot 4-4: Upper Band Edge – Peak – GFSK

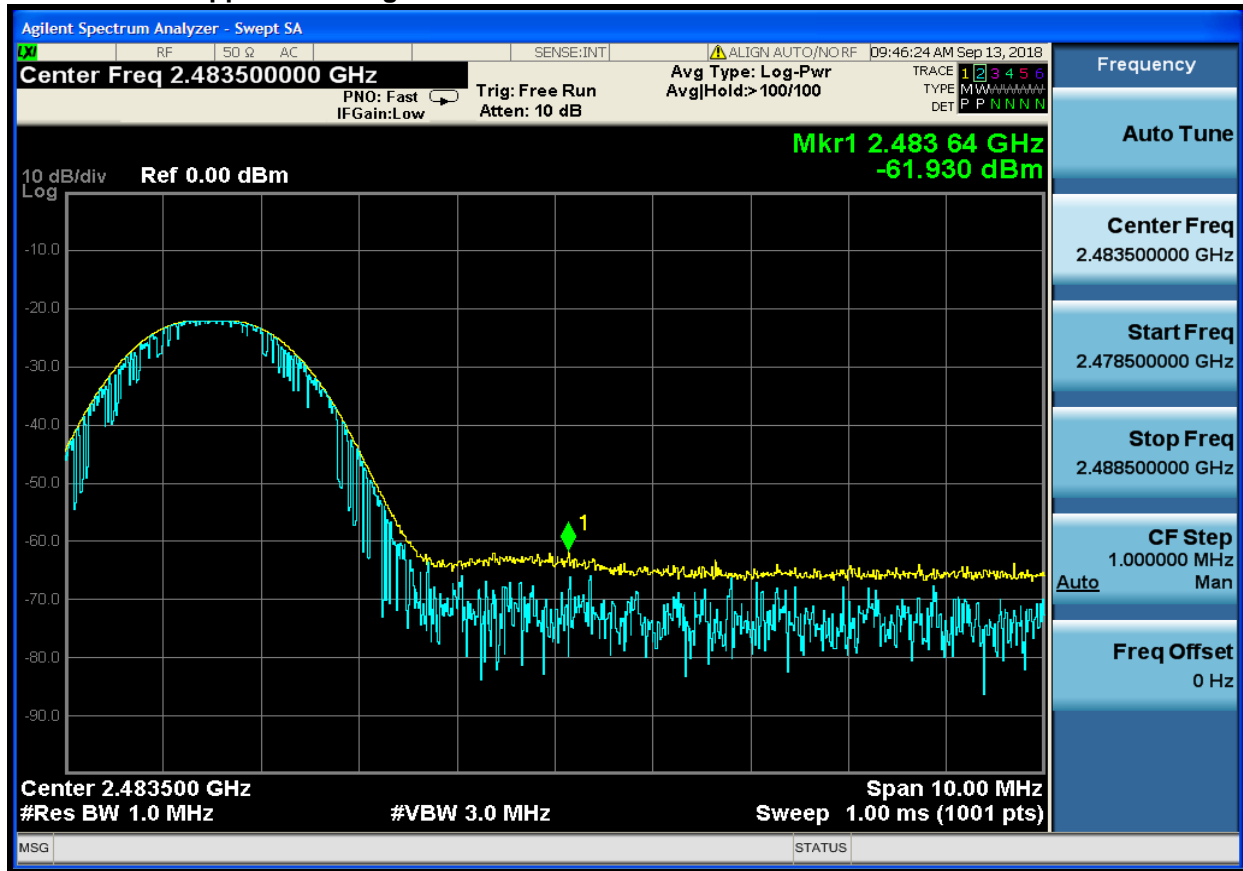

Table 4-5: Upper Band Edge Peak – GFSK

| Frequency (MHz) | Measured Peak Level (dBm) | Field Strength Conversion (dB μ V/m) | Peak Limit (dB μ V/m) | Margin (dB) |
|-----------------|---------------------------|--|---------------------------|-------------|
| 2483.64 | -61.9 | 33.3 | 74.0 | -40.7 |

Measurement uncertainty: ± 0.5 dB. This measurement uncertainty is an expanded uncertainty for 95% confidence level received with a coverage factor $k=2$.

Results: Pass

Test Personnel:

Khue Do
 Test Engineer

[Handwritten Signature]
 Signature

September 13, 2018
 Date of Test

5 Antenna Conducted Spurious Emissions – FCC 15.247(d); RSS-247 5.5, RSS-Gen 6.13

5.1 Antenna Conducted Spurious Emissions Test Procedures

Antenna spurious emissions per FCC 15.247(d) were measured from the EUT antenna port using a 50-ohm spectrum analyzer with the resolution bandwidth set at 100 kHz, and the video bandwidth set at 100 kHz. The modulated carrier was identified at the following frequencies: 2402 MHz, 2440 MHz and 2480 MHz.

5.2 Antenna Conducted Spurious Emissions Test Results

No harmonics or spurs were found within 20 dB (note that we are reporting power as peak) of the carrier level from the carrier to the 10th harmonic of the carrier frequency.

Table 5-1: Antenna Conducted Spurious Emissions Test Equipment

| RTL Asset # | Manufacturer | Model | Part Type | Serial Number | Calibration Due Date |
|-------------|----------------------|--------|--------------------------------------|---------------|----------------------|
| 901583 | Agilent Technologies | N9010A | EXA Signal Analyzer (10 Hz-26.5 GHz) | MY51250846 | 2/6/20 |

Measurement uncertainty: ± 0.5 dB. This measurement uncertainty is an expanded uncertainty for 95% confidence level received with a coverage factor $k=2$.

Results: Pass

Test Personnel:

Khue Do
Test Engineer

Signature

September 12, 2018
Date of Test

6 Bandwidths – FCC 15.247(a)(1); RSS-247 5.1(a); RSS-Gen 6.7

6.1 Bandwidth Test Procedure

The 20 dB and 99% bandwidths per FCC 15.247(a)(1), RSS-247 5.1 and RSS-Gen 6.7 were measured using a 50-ohm spectrum analyzer.

The following conditions shall be observed for measuring the occupied bandwidth and x dB bandwidth:

- The transmitter shall be operated at its maximum carrier power measured under normal test conditions.
- The span of the spectrum analyzer shall be set large enough to capture all products of the modulation process, including the emission skirts, around the carrier frequency, but small enough to avoid having other emissions (e.g. on adjacent channels) within the span.
- The detector of the spectrum analyzer shall be set to “Sample”. However, a peak, or peak hold, may be used in place of the sampling detector since this usually produces a wider bandwidth than the actual bandwidth (worst-case measurement). Use of a peak hold (or “Max Hold”) may be necessary to determine the occupied/x dB bandwidth if the device is not transmitting continuously.
- The resolution bandwidth (RBW) shall be in the range of 1% to 5% of the actual occupied/x dB bandwidth and the video bandwidth (VBW) shall not be smaller than three times the RBW value. Video averaging is not permitted.

Table 6-1: Bandwidth Test Equipment

| RTL Asset # | Manufacturer | Model | Part Type | Serial Number | Calibration Due Date |
|-------------|----------------------|--------|--------------------------------------|---------------|----------------------|
| 901583 | Agilent Technologies | N9010A | EXA Signal Analyzer (10 Hz-26.5 GHz) | MY51250846 | 2/6/20 |

6.2 Modulated Bandwidth Test Results

Note: EUT was programmed to TX with GFSK modulation, PN15 test pattern for all three test frequencies.

Table 6-2: Modulated Bandwidth Test Data – GFSK

| Frequency (MHz) | 20 dB Bandwidth (MHz) | 99% Bandwidth (MHz) |
|-----------------|-----------------------|---------------------|
| 2402 | 0.968 | 0.874 |
| 2440 | 0.929 | 0.873 |
| 2480 | 0.920 | 0.866 |

6.3 Bandwidth Plots

Plot 6-1: 20 dB Bandwidth – 2402 MHz – GFSK

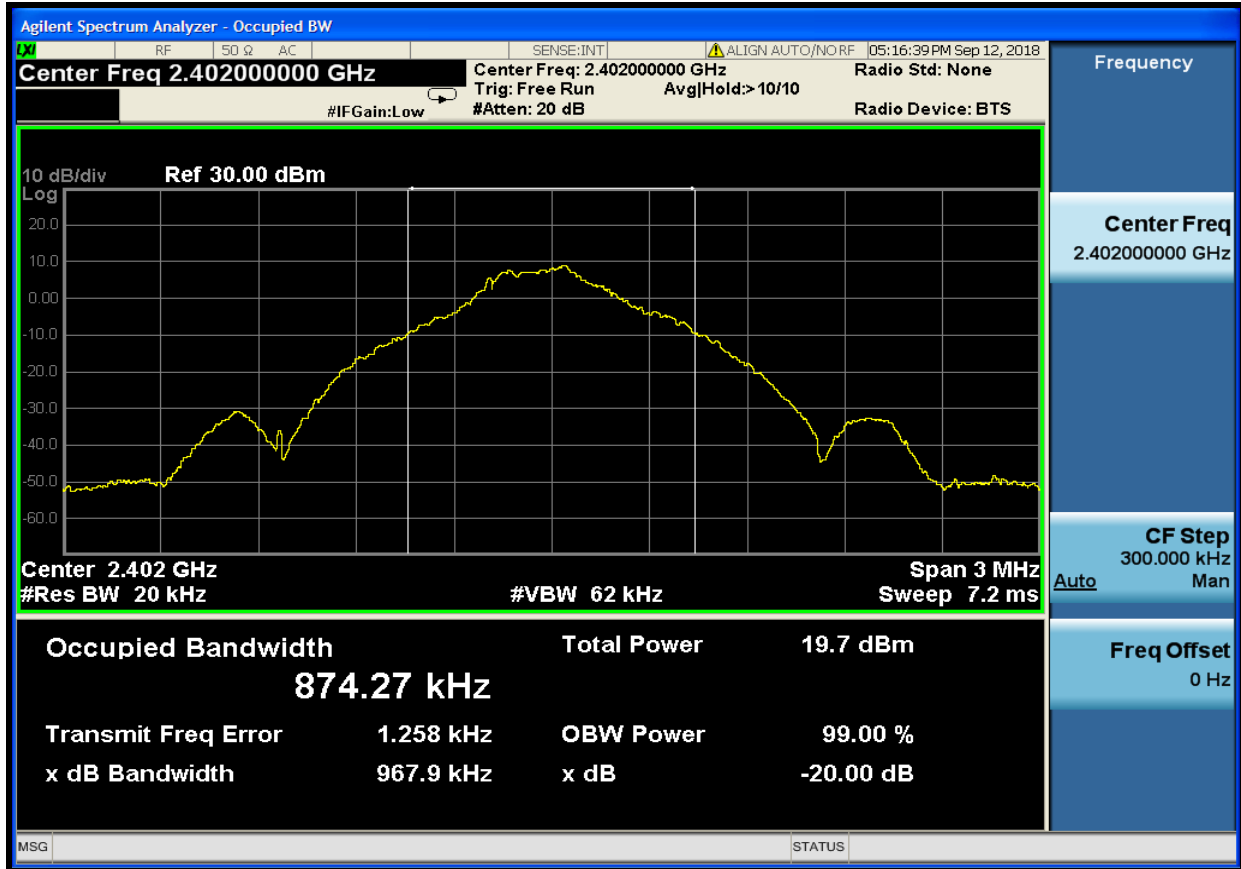

Plot 6-2: 20 dB Bandwidth – 2440 MHz – GFSK

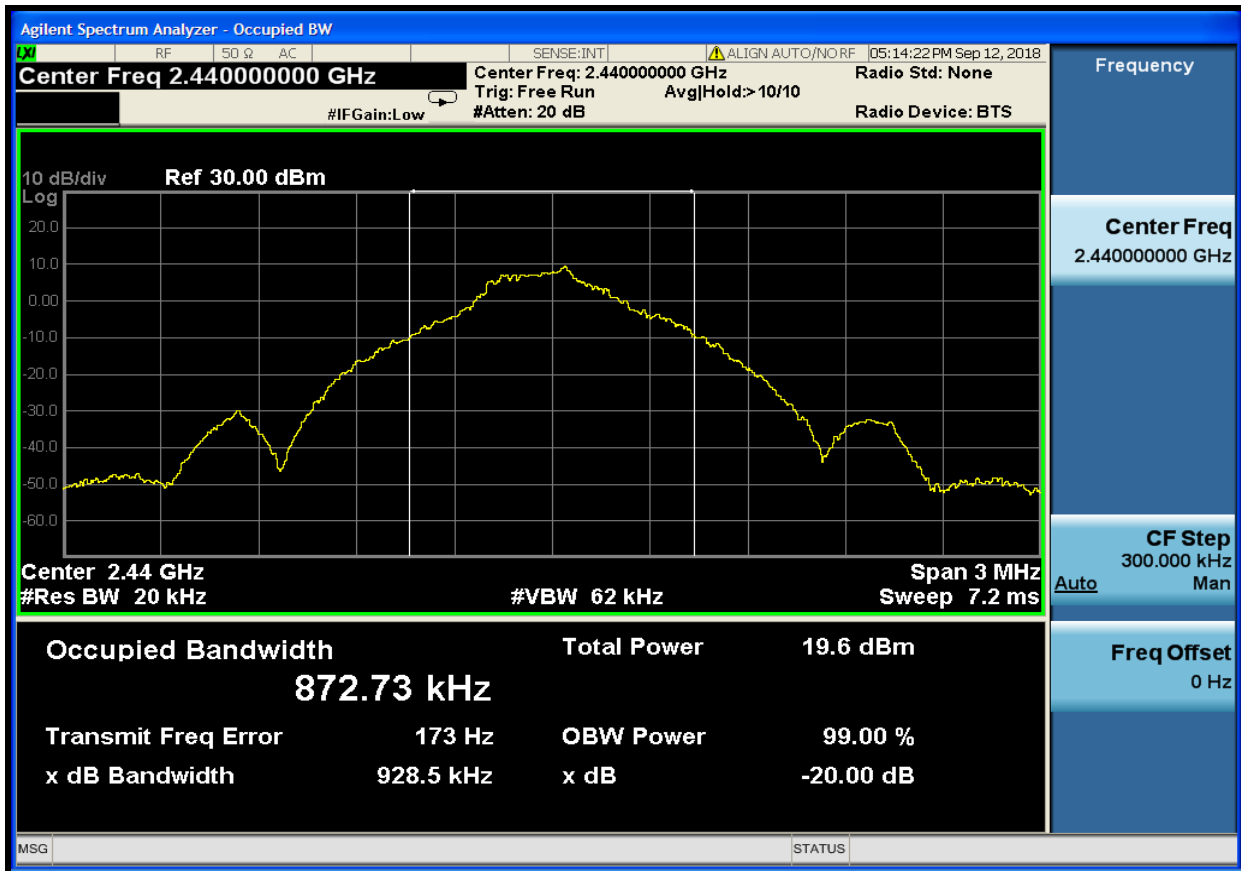

Plot 6-3: 20 dB Bandwidth – 2480 MHz – GFSK

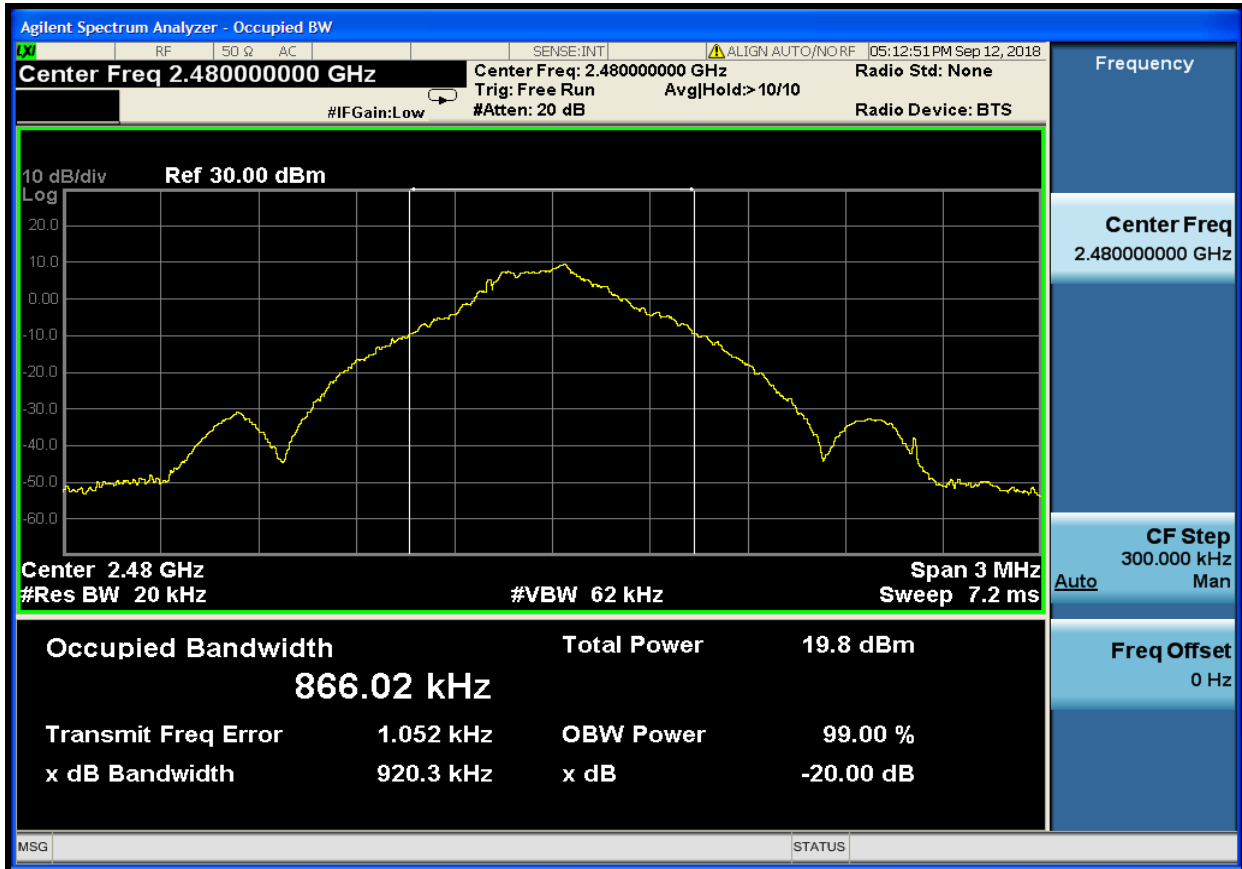

Plot 6-4: 99% Bandwidth – 2402 MHz – GFSK

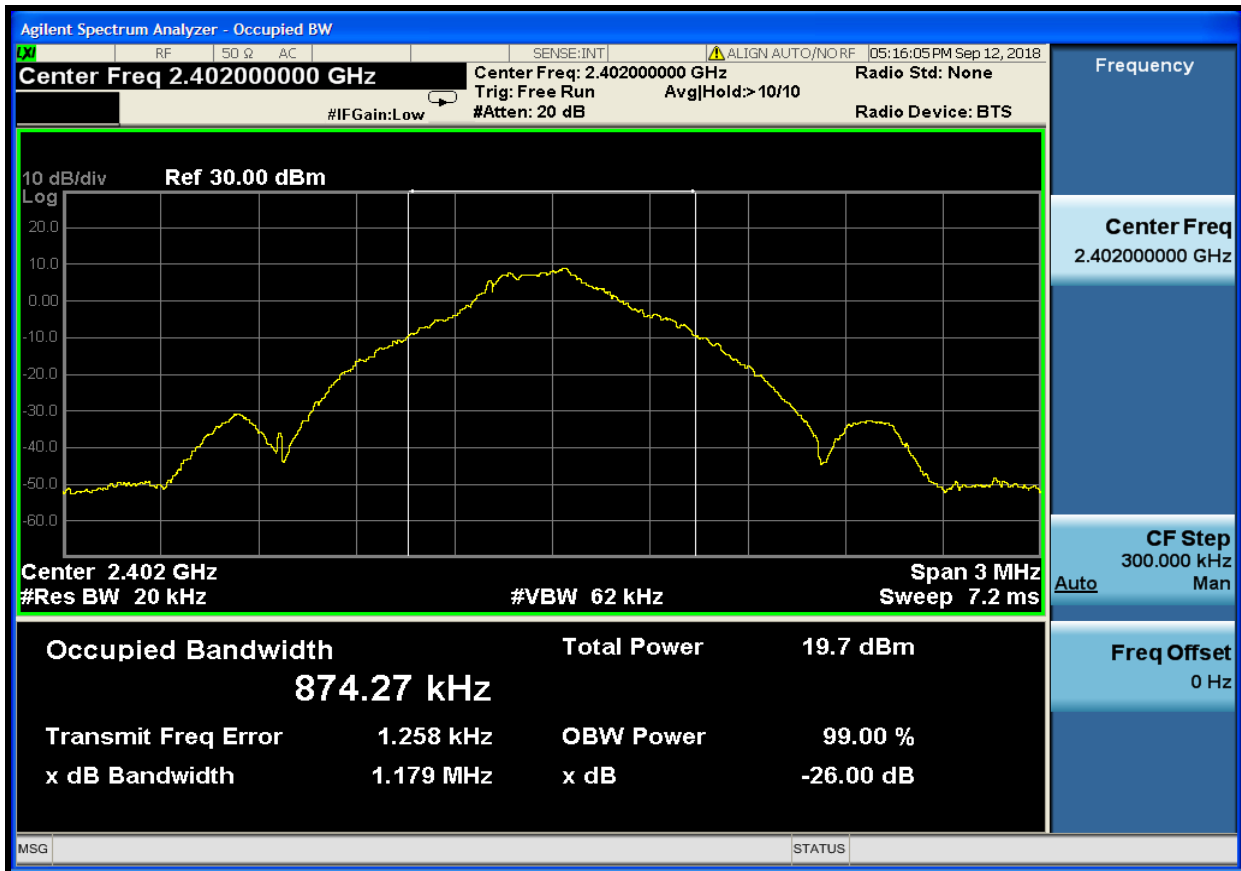

Plot 6-5: 99% Bandwidth – 2440 MHz – GFSK

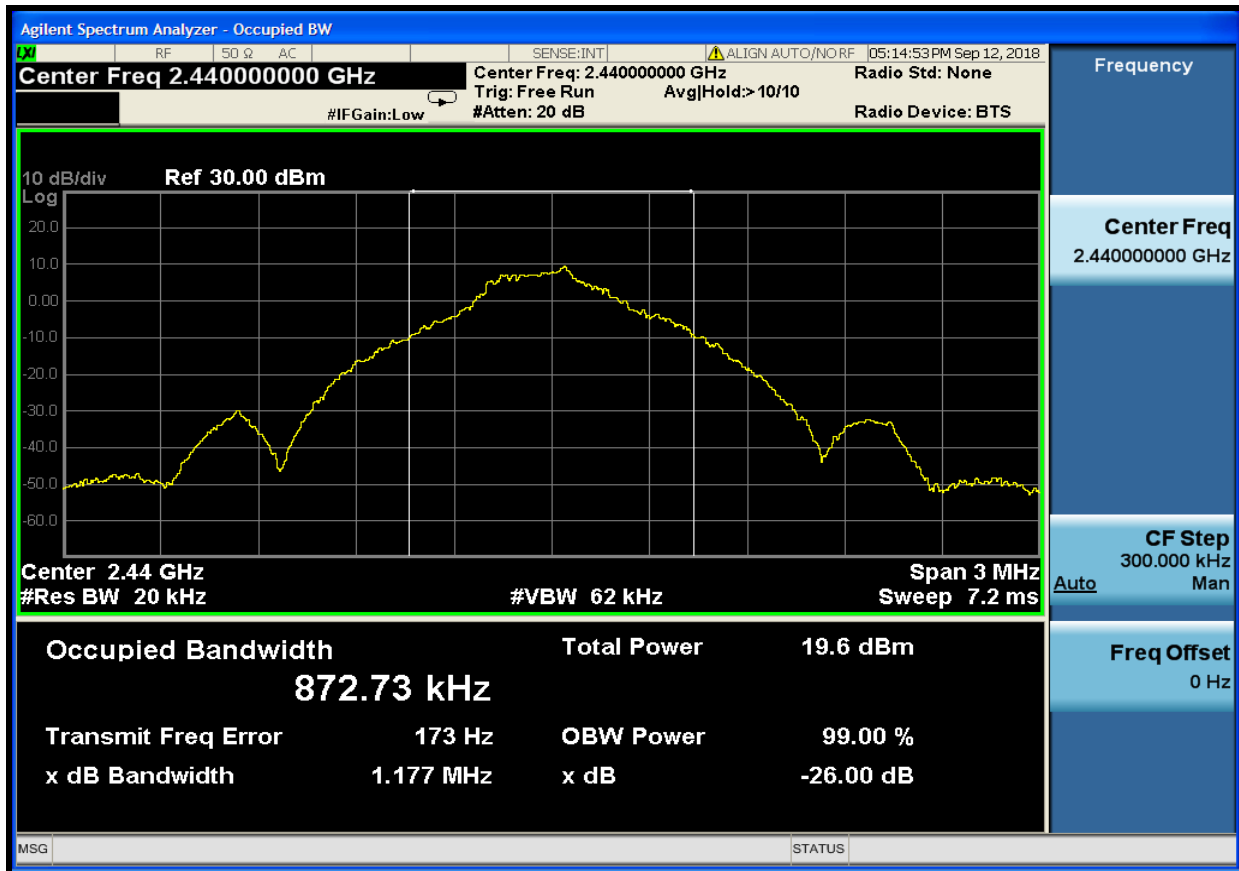

Plot 6-6: 99% Bandwidth – 2480 MHz – GFSK

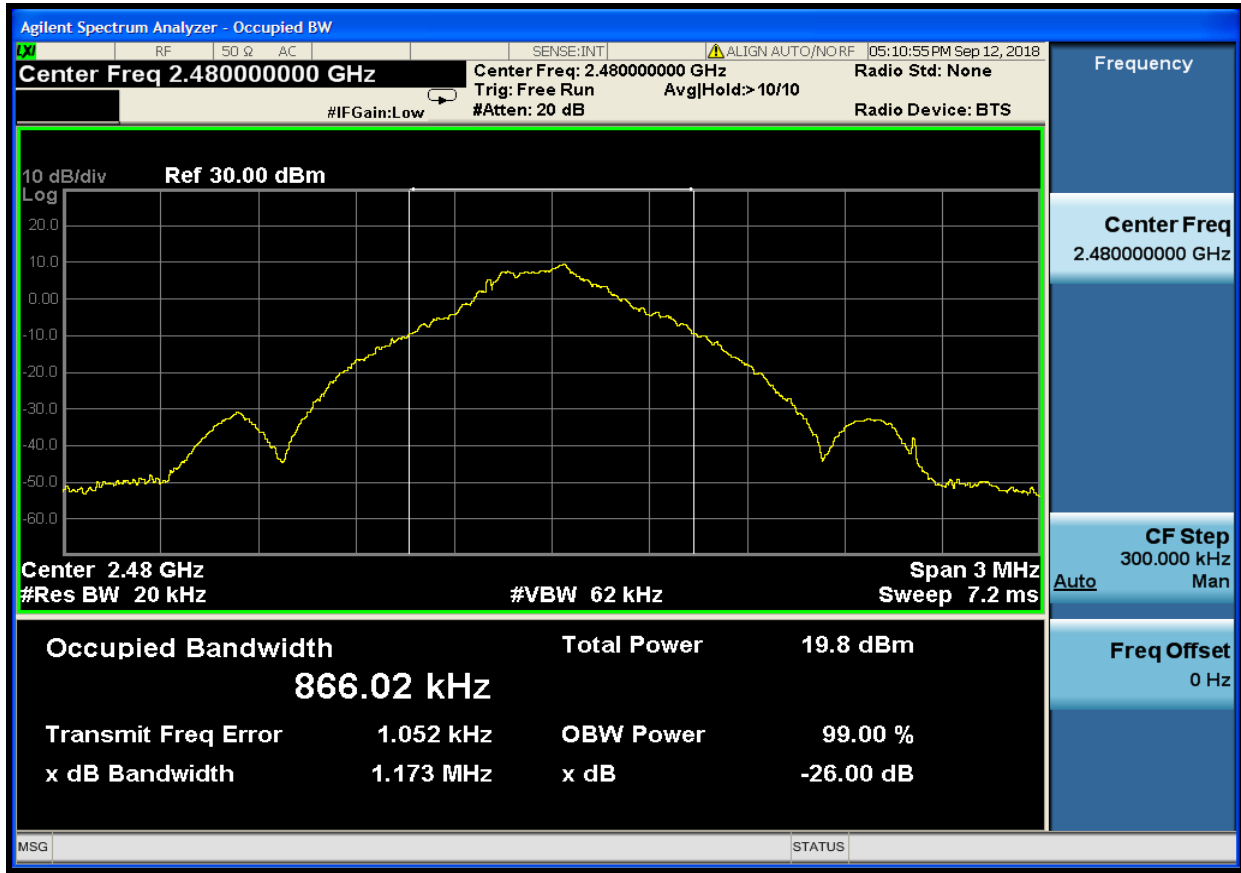

Measurement uncertainty: $\pm 1 \times 10^{-6}$ Hz. This measurement uncertainty is an expanded uncertainty for 95% confidence level received with a coverage factor k=2.

Test Personnel:

Khue Do
 Test Engineer

[Handwritten Signature]
 Signature

September 12, 2018
 Date of Test

7 Carrier Frequency Separation – FCC 15.247(a)(1); RSS-247 5.1(b)

7.1 Carrier Frequency Separation Test Procedure

Frequency hopping systems shall have hopping channel carrier frequencies separated by a minimum of 25 kHz or the 20 dB bandwidth of the hopping channel, whichever is greater.

Measured frequency separation = 1.00 MHz

Table 7-1: Carrier Frequency Separation Test Equipment

| RTL Asset # | Manufacturer | Model | Part Type | Serial Number | Calibration Due Date |
|-------------|----------------------|--------|--------------------------------------|---------------|----------------------|
| 901583 | Agilent Technologies | N9010A | EXA Signal Analyzer (10 Hz-26.5 GHz) | MY51250846 | 2/6/20 |

7.2 Carrier Frequency Separation Test Data

Plot 7-1: Carrier Frequency Separation



Frequency uncertainty: $\pm 1 \times 10^{-6}$ Hz. This measurement uncertainty is an expanded uncertainty for 95% confidence level received with a coverage factor $k=2$.

Test Personnel:

Khue Do
 Test Engineer

[Handwritten Signature]
 Signature

September 10, 2018
 Date of Test

8 Hopping Characteristics – FCC 15.247(a)(1)(iii); RSS-247 5.1(d)

8.1 Hopping Characteristics Test Procedure

Frequency hopping systems in the 2400–2483.5 MHz band shall use at least 15 channels. The average time of occupancy on any channel shall not be greater than 0.4 seconds within a period of 0.4 seconds multiplied by the number of hopping channels employed. Frequency hopping systems may avoid or suppress transmissions on a particular hopping frequency provided that a minimum of 15 channels is used.

Table 8-1: Hopping Characteristics Test Equipment

| RTL Asset # | Manufacturer | Model | Part Type | Serial Number | Calibration Due Date |
|-------------|----------------------|--------|--------------------------------------|---------------|----------------------|
| 901583 | Agilent Technologies | N9010A | EXA Signal Analyzer (10 Hz-26.5 GHz) | MY51250846 | 2/6/20 |

Plot 8-1: Number of Hopping Frequencies

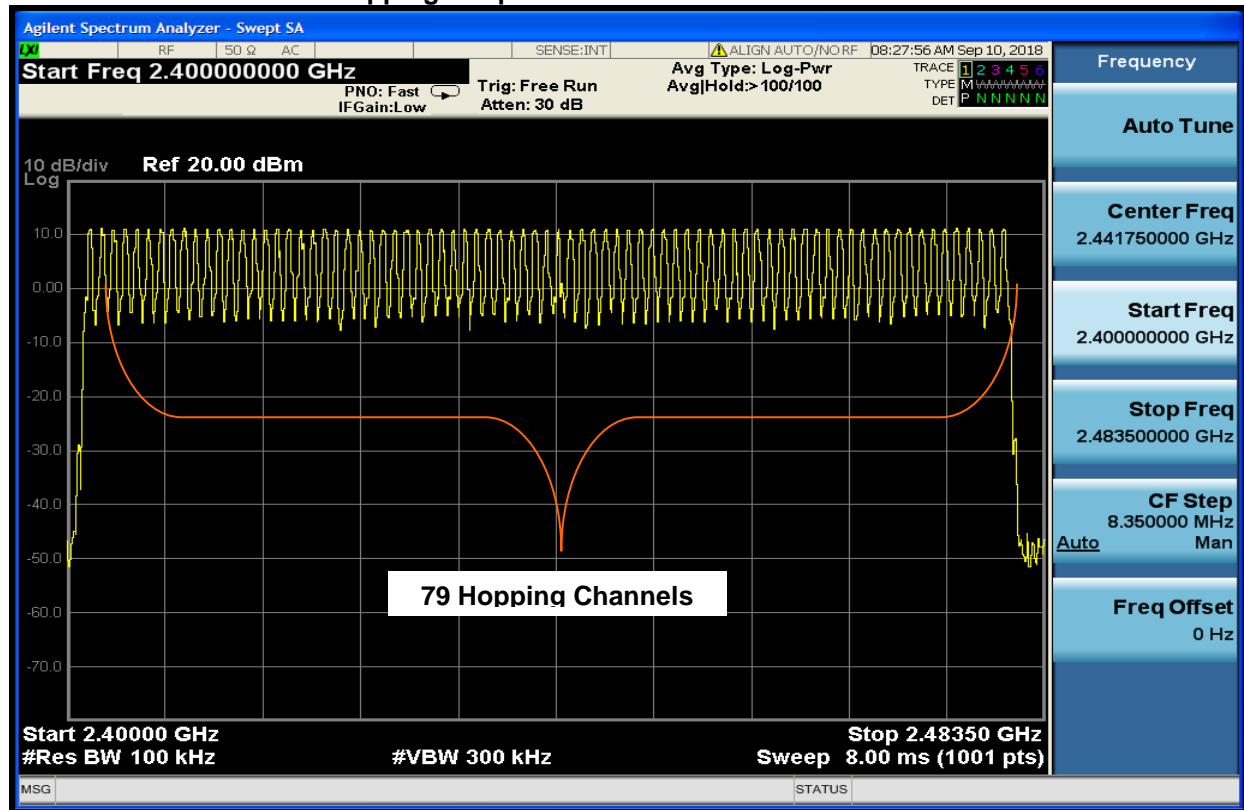

Frequency uncertainty: $\pm 1 \times 10^{-6}$ Hz. This measurement uncertainty is an expanded uncertainty for 95% confidence level received with a coverage factor $k=2$.

Test Personnel:

Khue Do
 Test Engineer

[Handwritten Signature]
 Signature

September 10, 2018
 Date of Test

8.2 Average Time of Occupancy – FCC 15.247(a)(1)(iii); RSS-247 5.1(d)

The spectrum analyzer gate function was used to determine the pulse width using the gate start and stop times, with a zero span to capture a pulse from the device under test. The delta response was used to measure the dwell time for this pulse. The sweep was then set to single sweep for 31.6 s.

The number of pulses in 31.6 s was 226.

The average time of occupancy in the above period (31.6 s) is equal to 226 pulses x 1.585 ms = 358.21 ms, which meets the limit as defined by 15.247(a)(iii) of 0.4 seconds.

Table 8-2: Average Time of Occupancy Test Equipment

| RTL Asset # | Manufacturer | Model | Part Type | Serial Number | Calibration Due Date |
|-------------|----------------------|--------|--------------------------------------|---------------|----------------------|
| 901583 | Agilent Technologies | N9010A | EXA Signal Analyzer (10 Hz-26.5 GHz) | MY51250846 | 2/6/20 |

Plot 8-2: Time of Occupancy (Dwell Time)

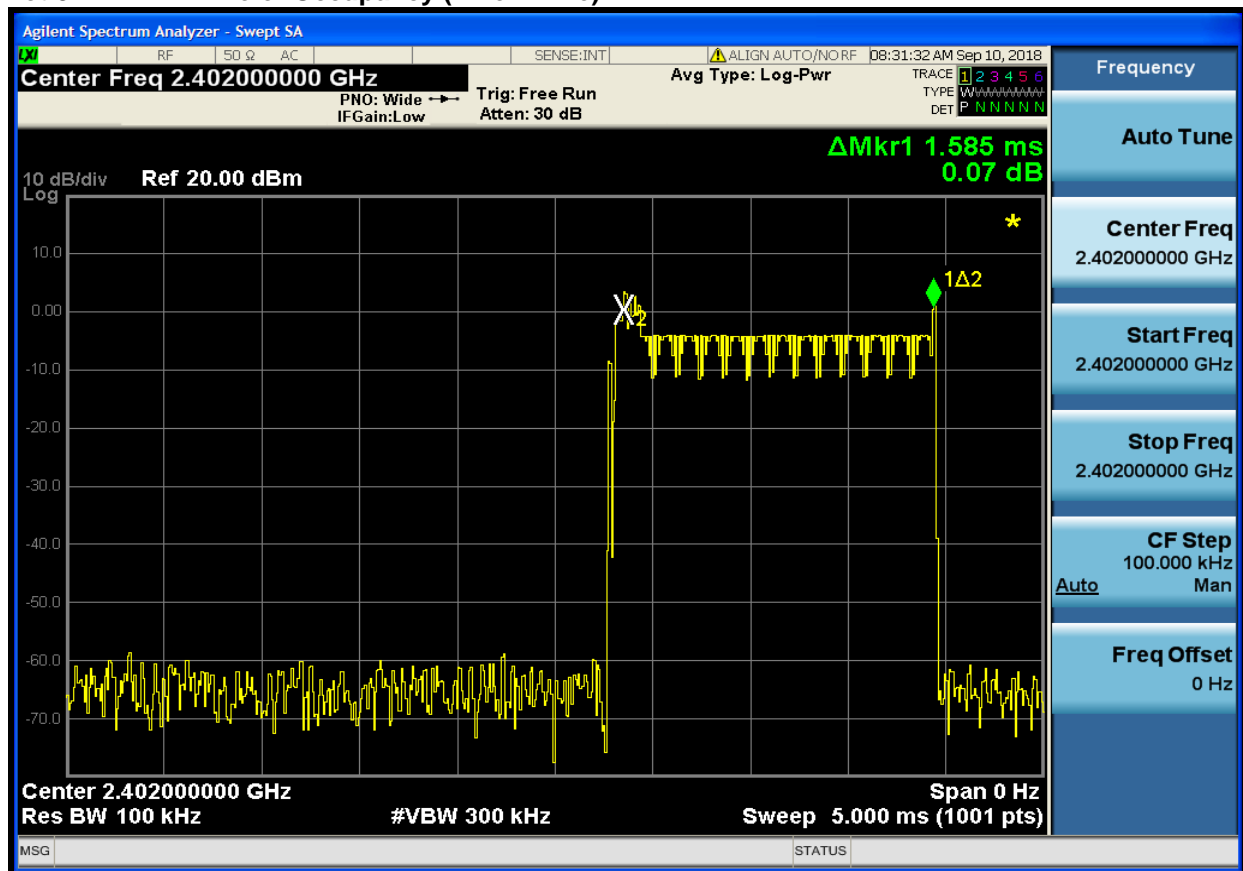

Plot 8-3: Time of Occupancy (Dwell Time 31.6 Second Sweep)



Number of pulses in 31.6 seconds: 226

The pulse width of 1.585 ms x 226 = 358.21 ms; less than the limit of 400 ms.

Results: Pass

Frequency uncertainty: $\pm 1 \times 10^{-6}$ Hz. This measurement uncertainty is an expanded uncertainty for 95% confidence level received with a coverage factor k=2.

Test Personnel:

Khue Do
 Test Engineer

[Handwritten Signature]
 Signature

September 10, 2018
 Date of Test

Rhein Tech Laboratories, Inc.
360 Herndon Parkway
Suite 1400
Herndon, VA 20170
<http://www.rheintech.com>

Client: Harris Corporation
Model #/HVIN: OWDTR-0161-E
Standards: FCC 15.247 & ISED RSS-247
ID's: OWDTR-0161-E/3636B-0161
Report #: 2019062DSS

9 AC Conducted Emissions – FCC 15.207; RSS-Gen 8.8

Device is a mobile 13.6 VDC equipment; AC line conducted emissions measurements are not required.

10 Radiated Emissions – FCC 15.209; RSS-247 5.5; RSS-Gen 8.9, 8.10

10.1 Limits of Radiated Emissions Measurement

| Frequency (MHz) | Field Strength ($\mu\text{V}/\text{m}$) | Measurement Distance (m) |
|-----------------|---|--------------------------|
| 0.009-0.490 | 2400/f (kHz) | 300 |
| 0.490-1.705 | 2400/f (kHz) | 30 |
| 1.705-30.0 | 30 | 30 |
| 30-88 | 100 | 3 |
| 88-216 | 150 | 3 |
| 216-960 | 200 | 3 |
| Above 960 | 500 | 3 |

As shown in 15.35(b), for frequencies above 1000 MHz, the field strength limits are based on average detector, however, the peak field strength of any emission shall not exceed the maximum permitted average limits, specified above by more than 20 dB under any circumstances of modulation.

10.2 Radiated Emissions Measurement Test Procedure

Before final measurements of radiated emissions were made on the open-field three/ten meter range, the EUT was scanned indoors at one and three meter distances. This was done in order to determine its emissions spectrum signature. The physical arrangement of the test system and associated cabling was varied in order to determine the effect on the EUT's emissions in amplitude, direction and frequency. This process was repeated during final radiated emissions measurements on the open-field range, at each frequency, in order to ensure that maximum emission amplitudes were attained.

Final radiated emissions measurements were made on the three/ten-meter, open-field test site. The EUT was placed on a nonconductive turntable 0.8 meters above the ground plane. The spectrum was examined from 9 kHz to the 10th harmonic of the highest fundamental transmitter frequency (24.8 GHz).

At each frequency, the EUT was rotated 360°, and the antenna was raised and lowered from 1 to 4 meters in order to determine the emission's maximum level. Measurements were taken using both horizontal and vertical antenna polarizations. For frequencies between 30 and 1000 MHz, the spectrum analyzer's 6 dB bandwidth was set to 120 kHz, and the analyzer was operated in the CISPR quasi-peak detection mode. For emissions above 1000 MHz, emissions are measured using the average detector function with a minimum resolution bandwidth of 1 MHz. No video filter less than 10 times the resolution bandwidth was used. The highest emission amplitudes relative to the appropriate limit were measured and recorded in this report.

Table 10-1: Radiated Emissions Test Equipment

| RTL Asset # | Manufacturer | Model | Part Type | Serial Number | Calibration Due Date |
|-------------|-----------------|----------|------------------------------|---------------|----------------------|
| 900772 | EMCO | 3161-02 | Horn Antenna (2.0–4.0 GHz) | 9804-1044 | 5/17/21 |
| 900321 | EMCO | 3161-03 | Horn Antennas (4.0–8.2 GHz) | 9508-1020 | 5/17/21 |
| 900323 | EMCO | 3160-7 | Horn Antennas (8.2–12.4 GHz) | 9605-1054 | 5/17/21 |
| 900356 | EMCO | 3160-08 | Horn Antenna (12.4–18.0 GHz) | 9607-1044 | 5/17/21 |
| 901218 | EMCO | 3160-09 | Horn Antenna (18.0–26.5 GHz) | 960281-003 | 5/17/21 |
| 900791 | Chase | CBL6111B | Bilog Antenna (30–2000 MHz) | N/A | 10/4/20 |
| 901581 | Rohde & Schwarz | FSU | Spectrum Analyzer | 1166.1660.50 | 4/26/21 |

10.3 Radiated Emissions Test Results

Table 10-2: Radiated Emissions Harmonics/Spurious – GFSK - 2402 MHz, Peak Detector

| Frequency (MHz) | Peak Analyzer (dBµV/m) | Site Correction Factor (dB/m) | Peak Corrected (dBµV/m) | Peak Limit (dBµV/m) | Peak Margin (dB) |
|-----------------|------------------------|-------------------------------|-------------------------|---------------------|------------------|
| 4804.0 | 29.8 | 35.6 | 65.4 | 74.0 | -8.6 |
| 12010.0 | 13.7 | 44.1 | 57.7 | 74.0 | -16.3 |
| 19216.0 | -4.8 | 53.3 | 48.6 | 74.0 | -25.4 |

Table 10-3: Radiated Emissions Harmonics/Spurious – GFSK - 2402 MHz, Average Detector

| Frequency (MHz) | Average Analyzer (dBµV/m) | Site Correction Factor (dB/m) | Average Corrected (dBµV/m) | Average Limit (dBµV/m) | Average Margin (dB) |
|-----------------|---------------------------|-------------------------------|----------------------------|------------------------|---------------------|
| 4804.0 | -6.0 | 35.6 | 29.6 | 54.0 | -24.4 |
| 12010.0 | -31.0 | 44.1 | 13.1 | 54.0 | -40.9 |
| 19216.0 | -48.3 | 53.3 | 5.1 | 54.0 | -48.9 |

Table 10-4: Radiated Emissions Harmonics/Spurious – GFSK - 2440 MHz, Peak Detector

| Frequency (MHz) | Peak Analyzer (dB μ V/m) | Site Correction Factor (dB/m) | Peak Corrected (dB μ V/m) | Peak Limit (dB μ V/m) | Peak Margin (dB) |
|-----------------|------------------------------|-------------------------------|-------------------------------|---------------------------|------------------|
| 4880.0 | 30.4 | 33.5 | 63.9 | 74.0 | -10.1 |
| 7320.0 | 13.4 | 35.8 | 49.1 | 74.0 | -24.9 |
| 12200.0 | 12.8 | 44.1 | 56.8 | 74.0 | -17.2 |
| 19520.0 | -4.3 | 53.6 | 49.3 | 74.0 | -24.7 |

Table 10-5: Radiated Emissions Harmonics/Spurious – GFSK - 2440 MHz, Average Detector

| Frequency (MHz) | Average Analyzer (dB μ V/m) | Site Correction Factor (dB/m) | Average Corrected (dB μ V/m) | Average Limit (dB μ V/m) | Average Margin (dB) |
|-----------------|---------------------------------|-------------------------------|----------------------------------|------------------------------|---------------------|
| 4880.0 | -5.3 | 33.5 | 28.2 | 54.0 | -25.8 |
| 7320.0 | -31.6 | 35.8 | 4.2 | 54.0 | -49.8 |
| 12200.0 | -31.3 | 44.1 | 12.7 | 54.0 | -41.3 |
| 19520.0 | -47.5 | 53.6 | 6.1 | 54.0 | -47.9 |

Table 10-6: Radiated Emissions Harmonics/Spurious – GFSK - 2480 MHz, Peak Detector

| Frequency (MHz) | Peak Analyzer (dB μ V/m) | Site Correction Factor (dB/m) | Peak Corrected (dB μ V/m) | Peak Limit (dB μ V/m) | Peak Margin (dB) |
|-----------------|------------------------------|-------------------------------|-------------------------------|---------------------------|------------------|
| 4960.0 | 29.9 | 33.7 | 63.6 | 74.0 | -10.4 |
| 7440.0 | 2.0 | 35.9 | 37.9 | 74.0 | -36.1 |
| 12400.0 | 5.0 | 47.2 | 52.2 | 74.0 | -21.8 |
| 19840.0 | 4.9 | 53.7 | 58.6 | 74.0 | -15.4 |
| 22320.0 | 5.7 | 55.8 | 61.4 | 74.0 | -12.6 |

Table 10-7: Radiated Emissions Harmonics/Spurious – GFSK - 2480 MHz, Average Detector

| Frequency (MHz) | Average Analyzer (dBµV/m) | Site Correction Factor (dB/m) | Average Corrected (dBµV/m) | Average Limit (dBµV/m) | Average Margin (dB) |
|-----------------|---------------------------|-------------------------------|----------------------------|------------------------|---------------------|
| 4960.0 | -5.8 | 33.7 | 27.8 | 54.0 | -26.2 |
| 7440.0 | -40.9 | 35.9 | -5.0 | 54.0 | -59.0 |
| 12400.0 | -39.0 | 47.2 | 8.2 | 54.0 | -45.8 |
| 19840.0 | -38.1 | 53.7 | 15.6 | 54.0 | -38.4 |
| 22320.0 | -37.6 | 55.8 | 18.2 | 54.0 | -35.8 |

Table 10-8: Radiated Emissions Harmonics/Spurious – 2-EDR - 2402 MHz, Peak Detector

| Frequency (MHz) | Peak Analyzer (dBµV/m) | Site Correction Factor (dB/m) | Peak Corrected (dBµV/m) | Peak Limit (dBµV/m) | Peak Margin (dB) |
|-----------------|------------------------|-------------------------------|-------------------------|---------------------|------------------|
| 4804.0 | 25.8 | 35.6 | 61.4 | 74.0 | -12.6 |
| 12010.0 | 12.6 | 44.1 | 56.7 | 74.0 | -17.3 |
| 19216.0 | 4.8 | 53.3 | 58.1 | 74.0 | -15.9 |

Table 10-9: Radiated Emissions Harmonics/Spurious – 2-EDR - 2402 MHz, Average Detector

| Frequency (MHz) | Average Analyzer (dBµV/m) | Site Correction Factor (dB/m) | Average Corrected (dBµV/m) | Average Limit (dBµV/m) | Average Margin (dB) |
|-----------------|---------------------------|-------------------------------|----------------------------|------------------------|---------------------|
| 4804.0 | -14.7 | 35.6 | 20.9 | 54.0 | -33.1 |
| 12010.0 | -31.2 | 44.1 | 12.9 | 54.0 | -41.1 |
| 19216.0 | -38.8 | 53.3 | 14.5 | 54.0 | -39.5 |

Table 10-10: Radiated Emissions Harmonics/Spurious – 2-EDR - 2440 MHz, Peak Detector

| Frequency (MHz) | Peak Analyzer (dBµV/m) | Site Correction Factor (dB/m) | Peak Corrected (dBµV/m) | Peak Limit (dBµV/m) | Peak Margin (dB) |
|-----------------|------------------------|-------------------------------|-------------------------|---------------------|------------------|
| 4880.0 | 26.9 | 33.5 | 60.4 | 74.0 | -13.6 |
| 7320.0 | 12.5 | 35.8 | 48.3 | 74.0 | -25.7 |
| 12200.0 | 12.9 | 44.1 | 57.0 | 74.0 | -17.0 |
| 19520.0 | 4.9 | 53.6 | 58.5 | 74.0 | -15.5 |

Table 10-11: Radiated Emissions Harmonics/Spurious – 2-EDR - 2440 MHz, Average Detector

| Frequency (MHz) | Average Analyzer (dBµV/m) | Site Correction Factor (dB/m) | Average Corrected (dBµV/m) | Average Limit (dBµV/m) | Average Margin (dB) |
|-----------------|---------------------------|-------------------------------|----------------------------|------------------------|---------------------|
| 4880.0 | -11.7 | 33.5 | 21.8 | 54.0 | -32.2 |
| 7320.0 | -31.5 | 35.8 | 4.3 | 54.0 | -49.7 |
| 12200.0 | -31.1 | 44.1 | 12.9 | 54.0 | -41.1 |
| 19520.0 | -37.9 | 53.6 | 15.7 | 54.0 | -38.3 |

Table 10-12: Radiated Emissions Harmonics/Spurious – 2-EDR - 2480 MHz, Peak Detector

| Frequency (MHz) | Peak Analyzer (dBµV/m) | Site Correction Factor (dB/m) | Peak Corrected (dBµV/m) | Peak Limit (dBµV/m) | Peak Margin (dB) |
|-----------------|------------------------|-------------------------------|-------------------------|---------------------|------------------|
| 4960.0 | 27.0 | 33.7 | 60.7 | 74.0 | -13.3 |
| 7440.0 | 11.5 | 35.9 | 47.4 | 74.0 | -26.6 |
| 12400.0 | 13.6 | 47.2 | 60.8 | 74.0 | -13.2 |
| 19840.0 | 14.6 | 53.7 | 68.3 | 74.0 | -5.7 |
| 22320.0 | 5.9 | 55.8 | 61.6 | 74.0 | -12.4 |

Table 10-13: Radiated Emissions Harmonics/Spurious –2-EDR - 2480 MHz, Average Detector

| Frequency (MHz) | Average Analyzer (dBµV/m) | Site Correction Factor (dB/m) | Average Corrected (dBµV/m) | Average Limit (dBµV/m) | Average Margin (dB) |
|-----------------|---------------------------|-------------------------------|----------------------------|------------------------|---------------------|
| 4960.0 | -11.2 | 33.7 | 22.4 | 54.0 | -31.6 |
| 7440.0 | -32.5 | 35.9 | 3.5 | 54.0 | -50.5 |
| 12400.0 | -30.5 | 47.2 | 16.7 | 54.0 | -37.3 |
| 19840.0 | -29.5 | 53.7 | 24.2 | 54.0 | -29.8 |
| 22320.0 | -37.7 | 55.8 | 18.1 | 54.0 | -35.9 |

Table 10-14: Radiated Emissions Harmonics/Spurious – 3-EDR - 2402 MHz, Peak Detector

| Frequency (MHz) | Peak Analyzer (dBµV/m) | Site Correction Factor (dB/m) | Peak Corrected (dBµV/m) | Peak Limit (dBµV/m) | Peak Margin (dB) |
|-----------------|------------------------|-------------------------------|-------------------------|---------------------|------------------|
| 4804.0 | 26.9 | 35.6 | 62.5 | 74.0 | -11.5 |
| 12010.0 | 13.2 | 44.1 | 57.3 | 74.0 | -16.7 |
| 19216.0 | 4.0 | 53.3 | 57.3 | 74.0 | -16.7 |

Table 10-15: Radiated Emissions Harmonics/Spurious – 3-EDR - 2402 MHz, Average Detector

| Frequency (MHz) | Average Analyzer (dBµV/m) | Site Correction Factor (dB/m) | Average Corrected (dBµV/m) | Average Limit (dBµV/m) | Average Margin (dB) |
|-----------------|---------------------------|-------------------------------|----------------------------|------------------------|---------------------|
| 4804.0 | -14.2 | 35.6 | 21.4 | 54.0 | -32.6 |
| 12010.0 | -31.2 | 44.1 | 12.9 | 54.0 | -41.1 |
| 19216.0 | -38.8 | 53.3 | 14.5 | 54.0 | -39.5 |

Table 10-16: Radiated Emissions Harmonics/Spurious – 3-EDR - 2440 MHz, Peak Detector

| Frequency (MHz) | Peak Analyzer (dBµV/m) | Site Correction Factor (dB/m) | Peak Corrected (dBµV/m) | Peak Limit (dBµV/m) | Peak Margin (dB) |
|-----------------|------------------------|-------------------------------|-------------------------|---------------------|------------------|
| 4880.0 | 27.1 | 33.5 | 60.6 | 74.0 | -13.4 |
| 7320.0 | 12.4 | 35.8 | 48.2 | 74.0 | -25.8 |
| 12200.0 | 13.1 | 44.1 | 57.1 | 74.0 | -16.9 |
| 19520.0 | 5.3 | 53.6 | 58.9 | 74.0 | -15.1 |

Table 10-17: Radiated Emissions Harmonics/Spurious – 3-EDR - 2440 MHz, Average Detector

| Frequency (MHz) | Average Analyzer (dBµV/m) | Site Correction Factor (dB/m) | Average Corrected (dBµV/m) | Average Limit (dBµV/m) | Average Margin (dB) |
|-----------------|---------------------------|-------------------------------|----------------------------|------------------------|---------------------|
| 4880.0 | -12.0 | 33.5 | 21.5 | 54.0 | -32.5 |
| 7320.0 | -31.7 | 35.8 | 4.1 | 54.0 | -49.9 |
| 12200.0 | -31.3 | 44.1 | 12.8 | 54.0 | -41.2 |
| 19520.0 | -37.7 | 53.6 | 15.9 | 54.0 | -38.1 |

Table 10-18: Radiated Emissions Harmonics/Spurious – 3-EDR - 2480 MHz, Peak Detector

| Frequency (MHz) | Peak Analyzer (dBµV/m) | Site Correction Factor (dB/m) | Peak Corrected (dBµV/m) | Peak Limit (dBµV/m) | Peak Margin (dB) |
|-----------------|------------------------|-------------------------------|-------------------------|---------------------|------------------|
| 4960.0 | 27.4 | 33.7 | 61.1 | 74.0 | -12.9 |
| 7440.0 | 12.0 | 35.9 | 47.9 | 74.0 | -26.1 |
| 12400.0 | 13.5 | 47.2 | 60.7 | 74.0 | -13.3 |
| 19840.0 | 14.9 | 53.7 | 68.6 | 74.0 | -5.4 |
| 22320.0 | 6.1 | 55.8 | 61.9 | 74.0 | -12.1 |

Table 10-19: Radiated Emissions Harmonics/Spurious – 3-EDR - 2480 MHz, Average Detector

| Frequency (MHz) | Average Analyzer (dB μ V/m) | Site Correction Factor (dB/m) | Average Corrected (dB μ V/m) | Average Limit (dB μ V/m) | Average Margin (dB) |
|-----------------|---------------------------------|-------------------------------|----------------------------------|------------------------------|---------------------|
| 4960.0 | -11.3 | 33.7 | 22.3 | 54.0 | -31.7 |
| 7440.0 | -32.2 | 35.9 | 3.7 | 54.0 | -50.3 |
| 12400.0 | -30.4 | 47.2 | 16.8 | 54.0 | -37.2 |
| 19840.0 | -29.1 | 53.7 | 24.7 | 54.0 | -29.3 |
| 22320.0 | -37.7 | 55.8 | 18.1 | 54.0 | -35.9 |

Table 10-20: Unintentional Emissions Test Data

| Temperature: 88.0°F Humidity: 34% | | | | | | | | | | |
|-----------------------------------|---------------|------------------------|-----------------------|--------------------|-------------------------|-------------------------------|-------------------------|----------------|-------------|-----------|
| Emission Frequency (MHz) | Test Detector | Antenna Polarity (H/V) | Turntable Azimuth (°) | Antenna Height (m) | Analyzer Reading (dBμV) | Site Correction Factor (dB/m) | Emission Level (dBμV/m) | Limit (dBμV/m) | Margin (dB) | Pass/Fail |
| 57.000 | QP | V | 180 | 1 | 54.8 | -28.8 | 26.0 | 40.0 | -14.0 | Pass |
| 83.330 | QP | V | 180 | 1 | 49.6 | -28.3 | 21.3 | 40.0 | -18.7 | Pass |
| 120.000 | QP | V | 180 | 1 | 63.3 | -26.2 | 37.1 | 43.5 | -6.4 | Pass |
| 125.000 | QP | V | 180 | 1 | 51.6 | -26.7 | 24.9 | 43.5 | -18.6 | Pass |
| 175.000 | QP | V | 180 | 1 | 54.7 | -25.1 | 29.6 | 43.5 | -13.9 | Pass |
| 225.000 | QP | V | 180 | 1 | 39.1 | -23.2 | 15.8 | 46.0 | -30.2 | Pass |
| 250.000 | QP | V | 180 | 1 | 45.1 | -21.8 | 23.3 | 46.0 | -22.7 | Pass |
| 275.000 | QP | V | 180 | 1 | 39.5 | -20.8 | 18.8 | 46.0 | -27.2 | Pass |
| 347.764 | QP | V | 180 | 1 | 37.6 | -18.4 | 19.1 | 46.0 | -26.9 | Pass |
| 350.000 | QP | H | 180 | 1 | 40.9 | -18.3 | 22.6 | 46.0 | -23.4 | Pass |
| 359.761 | QP | H | 180 | 1 | 27.7 | -18.1 | 9.6 | 46.0 | -36.4 | Pass |
| 371.757 | QP | H | 180 | 1 | 32.1 | -18.6 | 13.5 | 46.0 | -32.5 | Pass |
| 383.763 | QP | V | 180 | 1 | 34.8 | -18.3 | 16.5 | 46.0 | -29.5 | Pass |
| 395.750 | QP | V | 180 | 1 | 43.6 | -17.0 | 26.6 | 46.0 | -19.4 | Pass |
| 400.000 | QP | H | 180 | 1 | 44.8 | -16.9 | 27.9 | 46.0 | -18.1 | Pass |
| 407.730 | QP | V | 180 | 1 | 31.6 | -16.4 | 15.2 | 46.0 | -30.8 | Pass |
| 419.743 | QP | H | 180 | 1 | 28.6 | -16.6 | 12.0 | 46.0 | -34.0 | Pass |
| 431.740 | QP | H | 180 | 1 | 28.5 | -17.1 | 11.4 | 46.0 | -34.6 | Pass |
| 443.736 | QP | H | 180 | 1 | 29.2 | -16.8 | 12.3 | 46.0 | -33.7 | Pass |
| 455.733 | QP | H | 180 | 1 | 26.6 | -16.2 | 10.4 | 46.0 | -35.6 | Pass |
| 467.729 | QP | H | 180 | 1 | 27.7 | -15.7 | 12.0 | 46.0 | -34.0 | Pass |
| 491.722 | QP | H | 180 | 1 | 27.3 | -15.5 | 11.9 | 46.0 | -34.1 | Pass |
| 503.719 | QP | H | 180 | 1 | 26.5 | -15.2 | 11.3 | 46.0 | -34.7 | Pass |
| 515.715 | QP | H | 180 | 1 | 38.4 | -14.5 | 23.9 | 46.0 | -22.1 | Pass |
| 527.712 | QP | H | 180 | 1 | 37.9 | -13.4 | 24.5 | 46.0 | -21.5 | Pass |
| 539.708 | QP | H | 180 | 1 | 39.6 | -13.2 | 26.5 | 46.0 | -19.5 | Pass |
| 551.705 | QP | H | 180 | 1 | 27.0 | -13.6 | 13.4 | 46.0 | -32.6 | Pass |
| 563.701 | QP | H | 180 | 1 | 32.5 | -14.2 | 18.3 | 46.0 | -27.7 | Pass |
| 611.613 | QP | H | 180 | 1 | 32.5 | -12.2 | 20.3 | 46.0 | -25.7 | Pass |
| 623.609 | QP | H | 180 | 1 | 39.1 | -12.1 | 27.0 | 46.0 | -19.0 | Pass |

Measurement uncertainty: ±4.7 dB. This measurement uncertainty is an expanded uncertainty for 95% confidence level received with a coverage factor k=2.

Results: Pass

Test Personnel:

Dan Baltzell
 Test Engineer

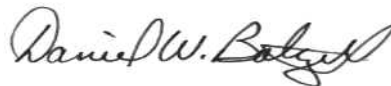

Signature

September 3/15, 2019
 Dates of Test

Rhein Tech Laboratories, Inc.
360 Herndon Parkway
Suite 1400
Herndon, VA 20170
<http://www.rheintech.com>

Client: Harris Corporation
Model #/HVIN: OWDTR-0161-E
Standards: FCC 15.247 & ISED RSS-247
ID's: OWDTR-0161-E/3636B-0161
Report #: 2019062DSS

11 Conclusion

The data in this DSS measurement report shows that the EUT as tested, Harris Corporation XL-200M Multi-Band Mobile, VL/V/U/7/8/9, Model #/HVIN XZ-MPM1M, FCC ID: OWDTR-0161-E, IC: 3636B-0161, complies with the applicable requirements of FCC Parts 2 and 15 and ISED RSS-247 and RSS-Gen.