



Engineering Solutions & Electromagnetic Compatibility Services

FCC & IC Certification Report

Harris Corporation
221 Jefferson Ridge Parkway
Lynchburg, VA 24501

Model: XG-25P UHF-L
Portable Radio

FCC ID: OWDTR-0141-E
IC: 3636B-0141

October 24, 2016

Standards Referenced for this Report	
Part 2: 2015	Frequency Allocations and Radio Treaty Matters; General Rules and Regulations
Part 22: 2015	Public Mobile Services
Part 80: 2015	Stations in the Maritime Services
Part 90: 2015	Private Land Mobile Radio Services
TIA-603-D 2010	Land Mobile FM or PM Communications Equipment Measurement and Performance Standards
Industry Canada RSS-119 Issue 12	Land Mobile and Fixed Equipment Operating in the Frequency Range 27.41-960 MHz

Report Prepared By: Dan Baltzell

Document Number: 2015075TNF

This report may not be reproduced, except in full, without the full written approval of Rhein Tech Laboratories, Inc. and Harris Corporation. Test results relate only to the item tested.

This/these test(s) is/are accredited under Rhein Tech Laboratories, Inc. ISO/IEC 17025 accreditation issued by the ANSI-ASQ National Accreditation Board. Refer to certificate and scope of accreditation AT-1445.

Frequency Range (MHz)	Rated Conducted Output Power (W)	Frequency Tolerance (ppm)	Transmit Mode	Emission Designator
400-406.0 (Federal)	5.0	0.2	Analog FM (NB)	11K0F3E
406.1-454 (FCC) 406.1-430 (IC)	5.0	0.2	Analog FM (NB)	11K0F3E
456-470 (FCC) 450-470 (IC)	5.0	0.2	Analog FM (NB)	11K0F3E
400-406.0 (Federal)	5.0	0.2	4-level FSK, digitized data/voice, P25 Phase 1, 9.6 kbps	8K40F1D/E
406.1-454 (FCC) 406.1-430 (IC)	5.0	0.2	4-level FSK, digitized data/voice, P25 Phase 1, 9.6 kbps	8K40F1D/E
456-470 (FCC) 450-470 (IC)	5.0	0.2	4-level FSK, digitized data/voice, P25 Phase 1, 9.6 kbps	8K40F1D/E
400-406.0 (Federal)	5.0	0.2	4-level FSK, digitized data/voice, P25 Phase 2 (H-CPM TDMA)	8K10DXW
406.1-454 (FCC) 406.1-430 (IC)	5.0	0.2	4-level FSK, digitized data/voice, P25 Phase 2 (H-CPM TDMA)	8K10DXW
456-470 (FCC) 450-470 (IC)	5.0	0.2	4-level FSK, digitized data/voice, P25 Phase 2 (H-CPM TDMA)	8K10DXW
400-406.0 (Federal)	5.0	0.2	2-level FSK, digitized data/voice, EDACS XNB 9.6 kbps (12.5 kHz)	11K7F1E/D
406.1-454 (FCC) 406.1-430 (IC)	5.0	0.2	2-level FSK, digitized data/voice, EDACS XNB 9.6 kbps (12.5 kHz)	11K7F1E/D
456-470 (FCC) 450-470 (IC)	5.0	0.2	2-level FSK, digitized data/voice, EDACS XNB 9.6 kbps (12.5 kHz)	11K7F1E/D
400-406.0 (Federal)	5.0	0.2	2-level FSK, digitized data/voice, EDACS XNB 4.8 kbps (12.5 kHz)	7K10F1E/D
406.1-454 (FCC) 406.1-430 (IC)	5.0	0.2	2-level FSK, digitized data/voice, EDACS XNB 4.8 kbps (12.5 kHz)	7K10F1E/D
456-470 (FCC) 450-470 (IC)	5.0	0.2	2-level FSK, digitized data/voice, EDACS XNB 4.8 kbps (12.5 kHz)	7K10F1E/D

Table of Contents

1	Test Result Summary	8
2	General Information	8
2.1	Test Facility	8
2.2	Related Submittal(s)/Grant(s)	8
2.3	Grant Notes	8
2.4	Tested System Details	9
3	FCC Part 2.1033(C)(8) Voltages and Currents through the Final Amplifying Stage	10
4	FCC Part 2.1046(a), 22.659, 80.215, 90.205; IC RSS-119 5.4: Transmitter Power	10
4.1	Test Procedure.....	10
4.2	Test Data.....	10
5	FCC Part 2.1051, 22.359, 80.217, 90.210; RSS-119 5.8: Conducted Spurious Emissions.....	11
5.1	Test Procedure.....	11
5.2	Test Data.....	12
6	FCC Part 2.1053(a), 22.359, 80.211(f)(3), 90.210; IC RSS-119 5.5, 5.8.9.2: Radiated Emissions....	25
6.1	Test Procedure.....	25
6.2	Test Data.....	25
7	FCC Part 2.1049(c)(1), 22.359(b), 80.205, 80.211, 90.210; IC RSS-119 5.5, 5.8: Bandwidths/Masks	32
7.1	Test Procedure.....	33
7.2	Test Data.....	34
8	FCC Part 2.1055, 22.355, 80.209, 90.213; IC RSS-119 5.3: Frequency Stability	91
8.1	Test Procedure.....	91
8.2	Test Data.....	93
8.2.1	Temperature Frequency Stability	93
8.2.2	Frequency Stability/Voltage Variation	95
9	FCC Part 2.1047(a)(b), 80.213; IC RSS-119 5.8: Modulation Characteristics	96
9.1	Test Procedures.....	96
9.1.1	Audio Frequency Response	96
9.1.2	Audio Low Pass Filter Response	96
9.1.3	Modulation Limiting	96
9.2	Test Data.....	97
9.2.1	Audio Frequency Response	97
9.2.2	Audio Low Pass Filter Response	98
9.2.3	Modulation Limiting	99
10	FCC Part 2.202: Necessary Bandwidth and Emission Bandwidth	101
11	Conclusion	101

Table of Figures

Figure 2-1: Configuration of Tested System.....	9
---	---

Table of Tables

Table 2-1: Equipment Under Test (EUT).....	9
Table 4-1: RF Conducted Output Power – Measured.....	10
Table 4-2: Test Equipment Used For Testing RF Power Output - Conducted.....	10
Table 5-1: Test Equipment Used For Testing Spurious Emissions.....	24
Table 6-1: Field Strength of Spurious Radiation – 378.0125 MHz.....	25
Table 6-2: Field Strength of Spurious Radiation – 406.1125 MHz.....	26
Table 6-3: Field Strength of Spurious Radiation – 418.0000 MHz.....	26
Table 6-4: Field Strength of Spurious Radiation – 429.9875 MHz.....	27
Table 6-5: Field Strength of Spurious Radiation – 450.0125 MHz.....	27
Table 6-6: Field Strength of Spurious Radiation – 454.0125 MHz.....	28
Table 6-7: Field Strength of Spurious Radiation – 456.0125 MHz.....	28
Table 6-8: Field Strength of Spurious Radiation – 458.9875 MHz.....	29
Table 6-9: Field Strength of Spurious Radiation – 459.0250 MHz.....	29
Table 6-10: Field Strength of Spurious Radiation – 459.9750 MHz.....	30
Table 6-11: Field Strength of Spurious Radiation – 469.9875 MHz.....	30
Table 6-12: Test Equipment Used For Testing Field Strength of Spurious Radiation	31
Table 7-1: Test Equipment Used For Testing Occupied Bandwidth	89
Table 8-1: Temperature Frequency Stability – 406.1125 MHz	93
Table 8-2: Temperature Frequency Stability – 459.9750 MHz	93
Table 8-3: Test Equipment Used For Testing Frequency Stability.....	94
Table 8-4: Frequency Stability/Voltage Variation – 406.1125 MHz.....	95
Table 8-5: Frequency Stability/Voltage Variation – 459.9750 MHz.....	95
Table 8-6: Test Equipment Used For Testing Frequency Stability.....	95
Table 9-1: Test Equipment Used For Testing Modulation Requirements	100

Table of Plots

Plot 5-1:	Spurious Emissions at Antenna Terminals – 378.0125 MHz.....	13
Plot 5-2:	Spurious Emissions at Antenna Terminals – 406.1125 MHz.....	14
Plot 5-3:	Spurious Emissions at Antenna Terminals – 418.0000 MHz.....	15
Plot 5-4:	Spurious Emissions at Antenna Terminals – 429.9875 MHz.....	16
Plot 5-5:	Spurious Emissions at Antenna Terminals – 450.0125 MHz.....	17
Plot 5-6:	Spurious Emissions at Antenna Terminals – 454.0125 MHz.....	18
Plot 5-7:	Spurious Emissions at Antenna Terminals – 456.0125 MHz.....	19
Plot 5-8:	Spurious Emissions at Antenna Terminals – 458.9875 MHz.....	20
Plot 5-9:	Spurious Emissions at Antenna Terminals – 459.0250 MHz.....	21
Plot 5-10:	Spurious Emissions at Antenna Terminals – 459.9750 MHz.....	22
Plot 5-11:	Spurious Emissions at Antenna Terminals – 469.9875 MHz.....	23
Plot 7-1:	Occupied Bandwidth – 450.0125 MHz; Analog (FCC Part 22).....	34
Plot 7-2:	Occupied Bandwidth – 450.01 MHz; Mask; (FCC Part 22)	35
Plot 7-3:	Occupied Bandwidth – 378.0125 MHz; Narrowband Analog; Mask D	36
Plot 7-4:	Occupied Bandwidth – 406.1125 MHz; Narrowband Analog; Mask D	37
Plot 7-5:	Occupied Bandwidth – 418.0000 MHz; Narrowband Analog; Mask D	38
Plot 7-6:	Occupied Bandwidth – 429.9875 MHz; Narrowband Analog; Mask D	39
Plot 7-7:	Occupied Bandwidth – 450.0125 MHz; Narrowband Analog; Mask D	40
Plot 7-8:	Occupied Bandwidth – 454.0125 MHz; Narrowband Analog; Mask D	41
Plot 7-9:	Occupied Bandwidth – 456.0125 MHz; Narrowband Analog; Mask D	42
Plot 7-10:	Occupied Bandwidth – 458.9875 MHz; Narrowband Analog; Mask D	43
Plot 7-11:	Occupied Bandwidth – 459.0250 MHz; Narrowband Analog; Mask D	44
Plot 7-12:	Occupied Bandwidth – 459.9750 MHz; Narrowband Analog; Mask D	45
Plot 7-13:	Occupied Bandwidth – 469.9875 MHz; Narrowband Analog; Mask D	46
Plot 7-14:	Occupied Bandwidth – 378.0125 MHz; Narrowband EDACS 9600 XNB; Mask D.....	47
Plot 7-15:	Occupied Bandwidth – 406.1125 MHz; Narrowband EDACS 9600 XNB; Mask D.....	48
Plot 7-16:	Occupied Bandwidth – 418.0000 MHz; Narrowband EDACS 9600 XNB; Mask D.....	49
Plot 7-17:	Occupied Bandwidth – 429.9875 MHz; Narrowband EDACS 9600 XNB; Mask D.....	50
Plot 7-18:	Occupied Bandwidth – 450.0125 MHz; Narrowband EDACS 9600 XNB; Mask D.....	51
Plot 7-19:	Occupied Bandwidth – 454.0125 MHz; Narrowband EDACS 9600 XNB; Mask D.....	52
Plot 7-20:	Occupied Bandwidth – 456.0125 MHz; Narrowband EDACS 9600 XNB; Mask D.....	53
Plot 7-21:	Occupied Bandwidth – 458.9875 MHz; Narrowband EDACS 9600 XNB; Mask D.....	54
Plot 7-22:	Occupied Bandwidth – 459.0250 MHz; Narrowband EDACS 9600 XNB; Mask D.....	55
Plot 7-23:	Occupied Bandwidth – 459.9750 MHz; Narrowband EDACS 9600 XNB; Mask D.....	56
Plot 7-24:	Occupied Bandwidth – 469.9875 MHz; Narrowband EDACS 9600 XNB; Mask D.....	57
Plot 7-25:	Occupied Bandwidth – 378.0125 MHz; Narrowband EDACS 4800 XNB; Mask D.....	58
Plot 7-26:	Occupied Bandwidth – 406.1125 MHz; Narrowband EDACS 4800 XNB; Mask D.....	59
Plot 7-27:	Occupied Bandwidth – 418.0000 MHz; Narrowband EDACS 4800 XNB; Mask D.....	60
Plot 7-28:	Occupied Bandwidth – 429.9875 MHz; Narrowband EDACS 4800 XNB; Mask D.....	61
Plot 7-29:	Occupied Bandwidth – 450.0125 MHz; Narrowband EDACS 4800 XNB; Mask D.....	62
Plot 7-30:	Occupied Bandwidth – 454.0125 MHz; Narrowband EDACS 4800 XNB; Mask D.....	63
Plot 7-31:	Occupied Bandwidth – 456.0125 MHz; Narrowband EDACS 4800 XNB; Mask D.....	64
Plot 7-32:	Occupied Bandwidth – 458.9875 MHz; Narrowband EDACS 4800 XNB; Mask D.....	65
Plot 7-33:	Occupied Bandwidth – 459.0250 MHz; Narrowband EDACS 4800 XNB; Mask D.....	66
Plot 7-34:	Occupied Bandwidth – 459.9750 MHz; Narrowband EDACS 4800 XNB; Mask D.....	67
Plot 7-35:	Occupied Bandwidth – 469.9875 MHz; Narrowband EDACS 4800 XNB; Mask D.....	68
Plot 7-36:	Occupied Bandwidth – 378.0125 MHz; Narrowband P25 Ph2; Mask D.....	69
Plot 7-37:	Occupied Bandwidth – 406.1125 MHz; Narrowband P25 Ph2; Mask D.....	70
Plot 7-38:	Occupied Bandwidth – 418.0000 MHz; Narrowband P25 Ph2; Mask D.....	71
Plot 7-39:	Occupied Bandwidth – 429.9875 MHz; Narrowband P25 Ph2; Mask D.....	72
Plot 7-40:	Occupied Bandwidth – 454.0125 MHz; Narrowband P25 Ph2; Mask D.....	73

Plot 7-41:	Occupied Bandwidth – 456.0125 MHz; Narrowband P25 Ph2; Mask D.....	74
Plot 7-42:	Occupied Bandwidth – 458.9875 MHz; Narrowband P25 Ph2; Mask D.....	75
Plot 7-43:	Occupied Bandwidth – 459.0250 MHz; Narrowband P25 Ph2; Mask D.....	76
Plot 7-44:	Occupied Bandwidth – 459.9750 MHz; Narrowband P25 Ph2; Mask D.....	77
Plot 7-45:	Occupied Bandwidth – 469.9875 MHz; Narrowband P25 Ph2; Mask D.....	78
Plot 7-46:	Occupied Bandwidth – 378.0125 MHz; Narrowband P25; Mask D	79
Plot 7-47:	Occupied Bandwidth – 406.1125 MHz; Narrowband P25; Mask D	80
Plot 7-48:	Occupied Bandwidth – 418.0000 MHz; Narrowband P25; Mask D	81
Plot 7-49:	Occupied Bandwidth – 429.9875 MHz; Narrowband P25; Mask D	82
Plot 7-50:	Occupied Bandwidth – 450.0125 MHz; Narrowband P25; Mask D	83
Plot 7-51:	Occupied Bandwidth – 454.0125 MHz; Narrowband P25; Mask D	84
Plot 7-52:	Occupied Bandwidth – 456.0125 MHz; Narrowband P25; Mask D	85
Plot 7-53:	Occupied Bandwidth – 458.9875 MHz; Narrowband P25; Mask D	86
Plot 7-54:	Occupied Bandwidth – 459.0250 MHz; Narrowband P25; Mask D	87
Plot 7-55:	Occupied Bandwidth – 459.9750 MHz; Narrowband P25; Mask D	88
Plot 7-56:	Occupied Bandwidth – 469.9875 MHz; Narrowband P25; Mask D	89
Plot 9-1:	Modulation Characteristics - Audio Frequency Response – 450.0125 MHz	97
Plot 9-2:	Modulation Characteristics – Audio Low Pass Filter – 450.0125 MHz	98
Plot 9-3:	Modulation Characteristics – Modulation Limiting – 450.0125 MHz; NB, Positive Peak....	99
Plot 9-4:	Modulation Characteristics – Modulation Limiting - 450.0125 MHz; NB, Negative Peak .	100

Table of Appendixes

Appendix A:	FCC Part 1.1307, 1.1310, 2.1091, 2.1093: RF Exposure	102
Appendix B:	Agency Authorization	103
Appendix C:	FCC & IC Confidentiality Request Letter	104
Appendix D:	IC Letters	105
Appendix E:	Canadian Based Representative Attestation Letter	106
Appendix F:	Extended Frequency Attestation Letter.....	107
Appendix G:	ID Label & Location	108
Appendix H:	Operational Description.....	110
Appendix I:	Parts List	111
Appendix J:	Test / Tune Procedure	112
Appendix K:	Schematics.....	113
Appendix L:	Block Diagram	114
Appendix M:	Manuals.....	115
Appendix N:	Test Configuration Photographs	116
Appendix O:	External Photographs.....	118
Appendix P:	Internal Photographs.....	123

Table of Photographs

Photograph 1: ID Label Sample – System Model.....	108
Photograph 2: ID Label Sample – Scan Model.....	108
Photograph 3: ID and RF Safety Label Location	109
Photograph 4: Radiated Emissions (Spurious/Harmonics) – Front View	116
Photograph 5: Radiated Emissions (Spurious/Harmonics) – Back View.....	117
Photograph 6: System Model and Scan Model	118
Photograph 7: Top View	119
Photograph 8: Bottom View	120
Photograph 9: PTT Side	121
Photograph 10: UDC Side	122
Photograph 11: Front Cover Removed	123
Photograph 12: Display.....	124
Photograph 13: Keypad	125
Photograph 14: Keypad Back with Cable	126
Photograph 15: RF Front View with GPS Antenna.....	127
Photograph 16: RF Back View with GPS Module.....	128
Photograph 17: Radio Shield	129

1 Test Result Summary

Test	FCC/IC Reference	Result
RF Power Output	2.1046(a), 22.659, 80.215, 90.205/ RSS-119 5.4	Complies
Spurious Emissions at Antenna Terminals	2.1051, 22.359, 80.217, 90.210/ RSS-119 5.8	Complies
Field Strength of Spurious Radiation	2.1053(a), 80.211, 90.210/ RSS-119 5.8.9.2	Complies
Occupied Bandwidth/Emission Masks	2.1049(c)(1), 22.359(b), 80.205, 90.210/ RSS-119 5.5	Complies
Frequency Stability vs. Temperature and Voltage	2.1055, 22.355, 80.209, 90.213/ RSS-119 5.3	Complies
Modulation Characteristics	2.1047(a)(b), 80.213/ RSS-119 5.8	Complies

2 General Information

The following Certification Report is prepared on behalf of Harris Corporation in accordance with the Federal Communications Commission and Industry Canada rules and regulations. The Equipment Under Test (EUT) was the **XG-25P UHF-L**, a Portable Radio family; **FCC ID: OWDTR-0141-E, IC: 3636B-0141**.

All measurements contained in this application were conducted in accordance with the applicable sections of FCC Rules and Regulations CFR 47 Parts 2, 22, 80 and 90, and Industry Canada RSS-119. Calibration checks are performed regularly on the instruments, and all accessories including high pass filter, coaxial attenuator, preamplifier and cables.

2.1 Test Facility

The open area test site and conducted measurement facility used to collect the radiated data is located on the parking lot of Rhein Tech Laboratories, Inc. 360 Herndon Parkway, Suite 1400, Herndon, Virginia 20170. This site has been fully described in a report submitted to, and approved by, the Federal Communications Commission to perform AC line conducted and radiated emissions testing.

2.2 Related Submittal(s)/Grant(s)

This is a new family certification application for Industry Canada. The XG-25P UHF-L portable radio family models to be certified at this time include the following model numbers: DPXG-PFU1B-e1 and DPXG-PBU1B-e1.

2.3 Grant Notes

RF power switchable from 1 W to rated power 5 W.

2.4 Tested System Details

The test sample was received on May 30, 2013. Listed below are the identifiers and descriptions of all equipment, cables, and internal devices used with the EUT for this test, as applicable.

The EUT includes a System model and a Scan model, the difference being that the System model has a DTMF keypad. The System model is considered to be representative of the radio family and to have the worst case emissions, and was therefore used for testing.

The device was programmed for multiple modes of operation and modulation types.

Table 2-1: Equipment Under Test (EUT)

Part	Manufacturer	Model #/HVIN	PN/SN	FCC ID	RTL Bar Code
XG-25P UHF-L Radio	Harris Corporation	DPXG-PFU1B-e1 (System)	14011-0030-01	OWDTR-0141-E	21045
XG-25P UHF-L Radio	Harris Corporation	DPXG-PBU1B-e1 (Scan)	14011-0030-02	OWDTR-0141-E	21046

Figure 2-1: Configuration of Tested System

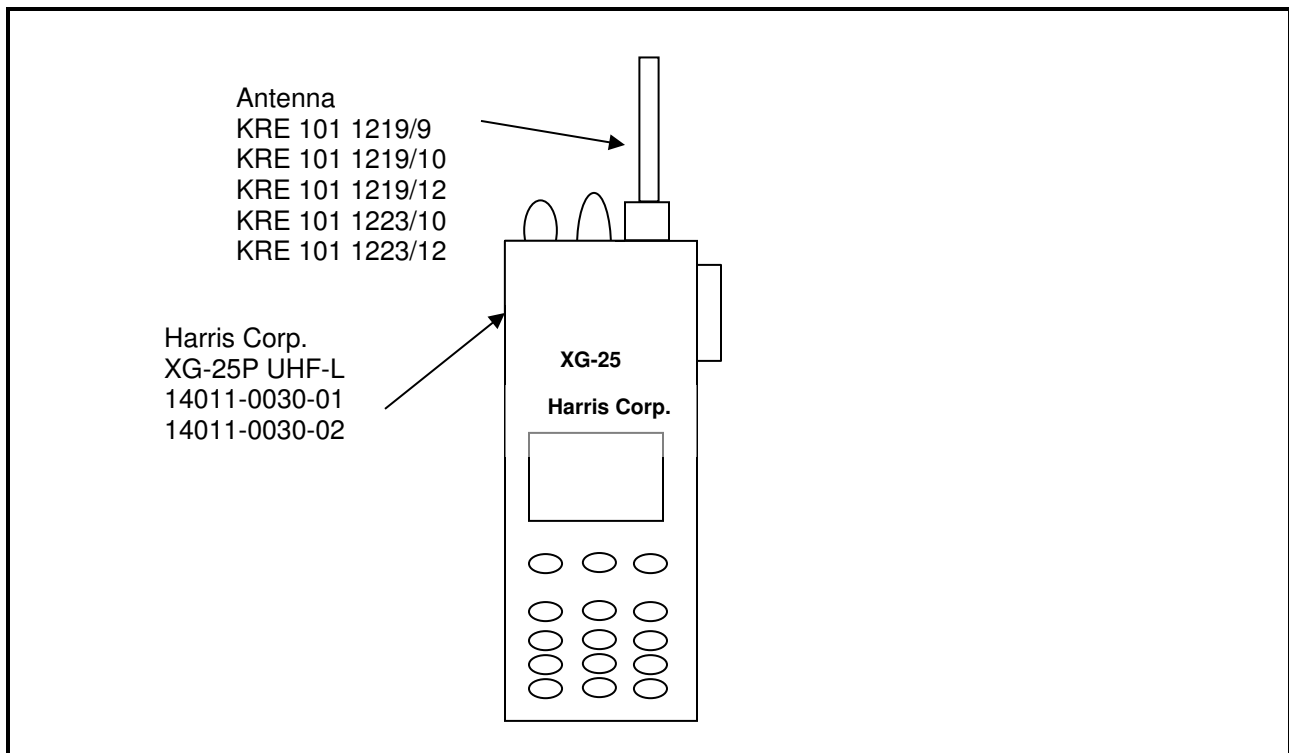

3 FCC Part 2.1033(C)(8) Voltages and Currents through the Final Amplifying Stage

7.5VDC (nominal) / 2.25 A (max)

4 FCC Part 2.1046(a), 22.659, 80.215, 90.205; IC RSS-119 5.4: Transmitter Power

4.1 Test Procedure

TIA-603-D 2010, Section 2.2.1

The EUT was connected to a coaxial attenuator having a 50 Ω load impedance.

Manufacturer's rated power: 5 W.

4.2 Test Data

Table 4-1: RF Conducted Output Power – Measured

Frequency (MHz)	High Power (dBm)	High Power (W)	Low?? Power (dBm)	Low?? Power (W)
378.0125	37.2	5.2	30.2	1.0
406.1125	37.1	5.1	30.3	1.1
418.0000	37.2	5.2	30.3	1.1
429.9875	37.2	5.2	30.3	1.1
450.0125	37.1	5.1	30.3	1.1
454.0125	37.1	5.1	30.2	1.0
456.0125	37.1	5.1	30.2	1.0
458.9875	37.1	5.1	30.2	1.0
459.0250	37.1	5.1	30.2	1.0
459.9750	37.2	5.2	30.3	1.1
469.9875	37.2	5.2	30.2	1.0

Notes: Data presented is for analog mode. All other modes were investigated and found to have equivalent power within measurement tolerances.

Table 4-2: Test Equipment Used For Testing RF Power Output - Conducted

RTL Asset #	Manufacturer	Model	Part Type	Serial Number	Calibration Due Date
901583	Agilent Technologies	N9010A	EXA Signal Analyzer (10 Hz - 26.5 GHz)	MY51250846	4/16/14
901337	Narda Microline	766-10	Attenuator, DC-4GHz, 10 dB, 20W	6242	8/17/13

Test Personnel:

Daniel Baltzell
 EMC Test Engineer



Signature

May 31, 2013
 Date of Test

5 FCC Part 2.1051, 22.359, 80.217, 90.210; RSS-119 5.8: Conducted Spurious Emissions

5.1 Test Procedure

TIA-603-D 2010, Section 2.2.13

The transmitter is terminated with a 50 Ω load and interfaced with a spectrum analyzer.

Device with digital modulation: Modulated to its maximum extent using a pseudo-random data sequence – 19,200 bps for OTP and 9,600 bps for P25 modes.

Part 80.217 Suppression of Interference Aboard Ships

(a) A voluntarily-equipped ship station receiver must not cause harmful interference to any receiver required by statute or treaty.

(b) The electromagnetic field from receivers required by statute or treaty must not exceed the following value at a distance over sea water of one nautical mile from the receiver:

Frequency of Interfering Emissions	Power to Artificial Antenna in Microwatts
Below 30 MHz	0.1
30 to 100 MHz	3.0
100 to 300 MHz	1.0
Over 300 MHz	3.0

or deliver not more than the following amounts of power to an artificial antenna having electrical characteristics equivalent to those of the average receiving antenna(s) used on shipboard:

Frequency of Interfering Emissions	Power to Artificial Antenna in Microwatts
Below 30 MHz	400 (4 dBm)
30 to 100 MHz	4,000 (6 dBm)
100 to 300 MHz	40,000 (16 dBm)
Over 300 MHz	400,000 (26 dBm)

5.2 Test Data

Frequency range of measurement per Part 2.1057: 9 kHz to 10 x Fc

Limits: (43+10LOG P(W)) for wideband and (50+10 LOG P(W)) for narrowband

The following channels (in MHz) were investigated:

UHF-L Test Frequencies
378.0125
406.1125
418.0000
429.9875
450.0125
454.0125
456.0125
458.9875
459.0250
459.9750
469.9875

Both high and low power settings were checked; high power was found to be worst case, and is presented. All modes were investigated and analog mode is presented as representative data.

Plot 5-1: Spurious Emissions at Antenna Terminals – 378.0125 MHz

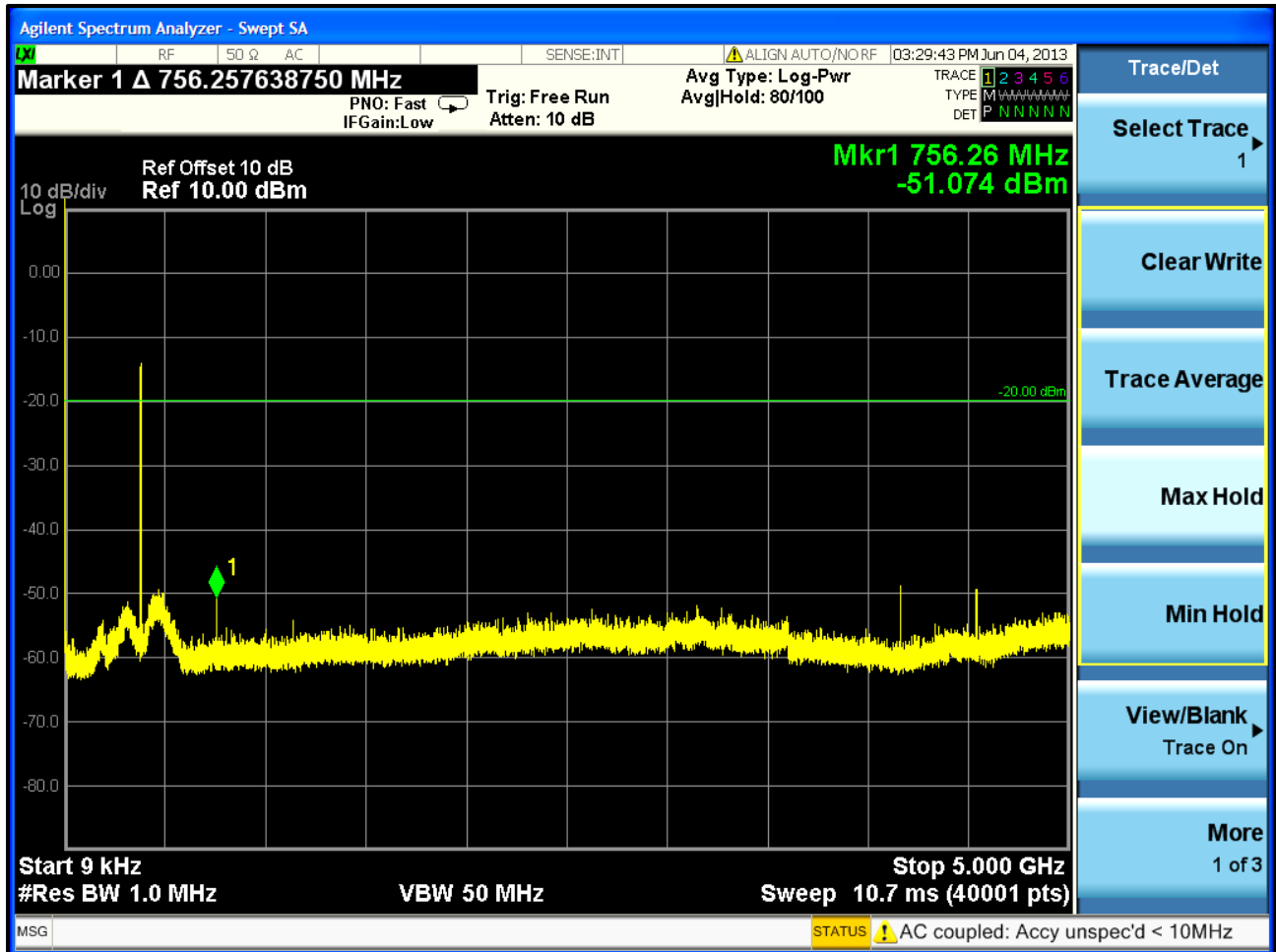

Plot 5-2: Spurious Emissions at Antenna Terminals – 406.1125 MHz

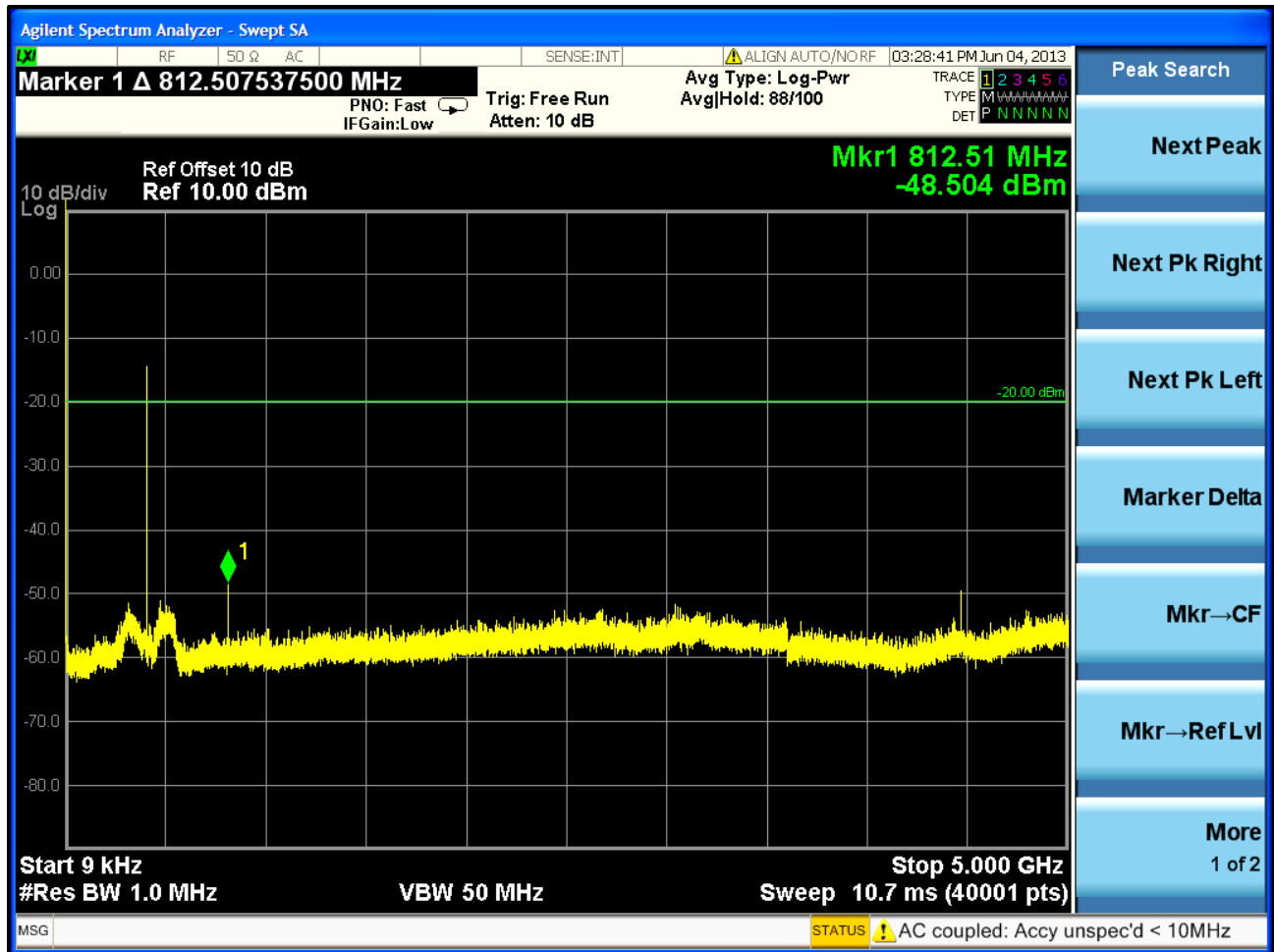

Plot 5-3: Spurious Emissions at Antenna Terminals – 418.0000 MHz

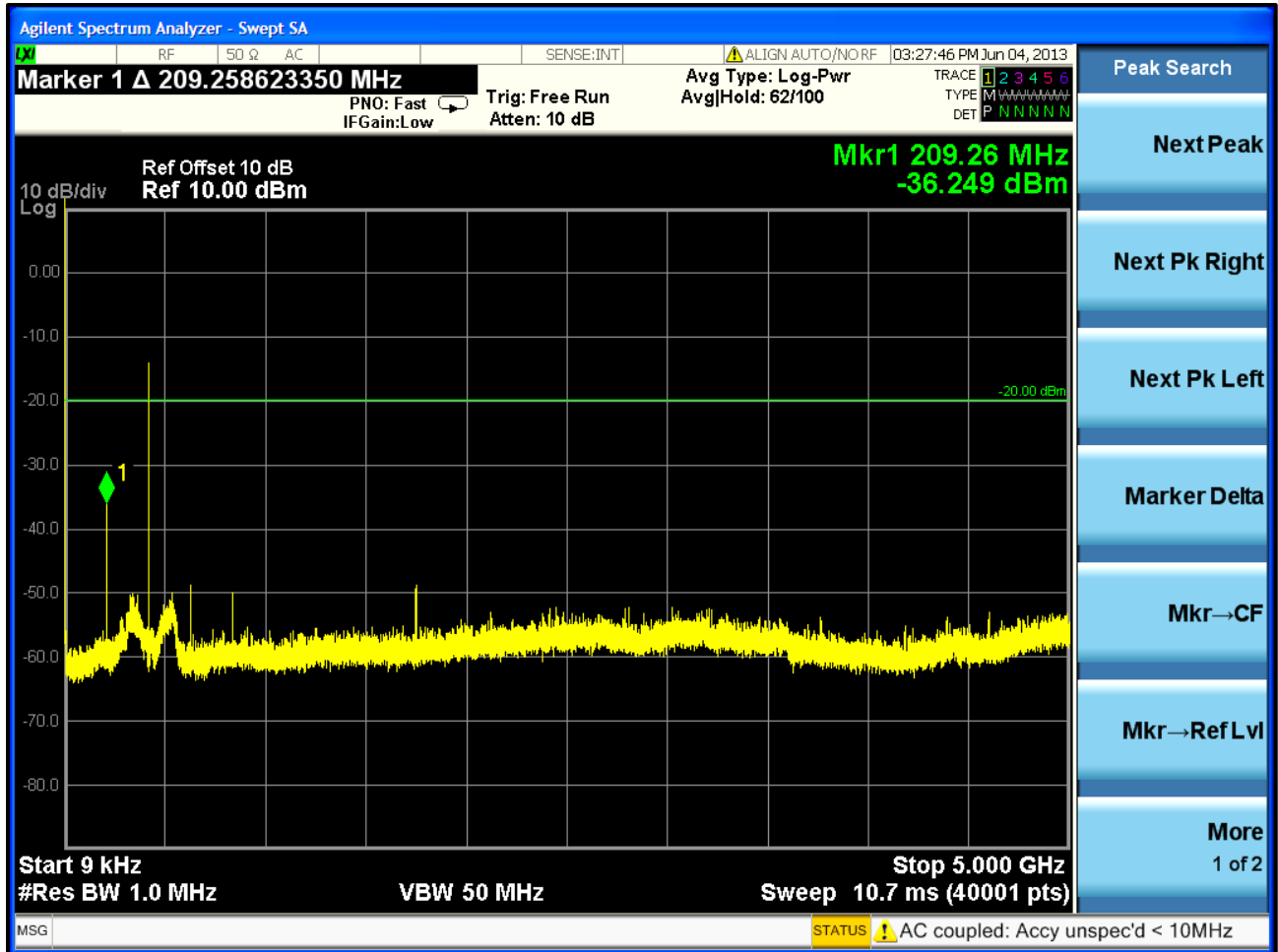

Plot 5-4: Spurious Emissions at Antenna Terminals – 429.9875 MHz

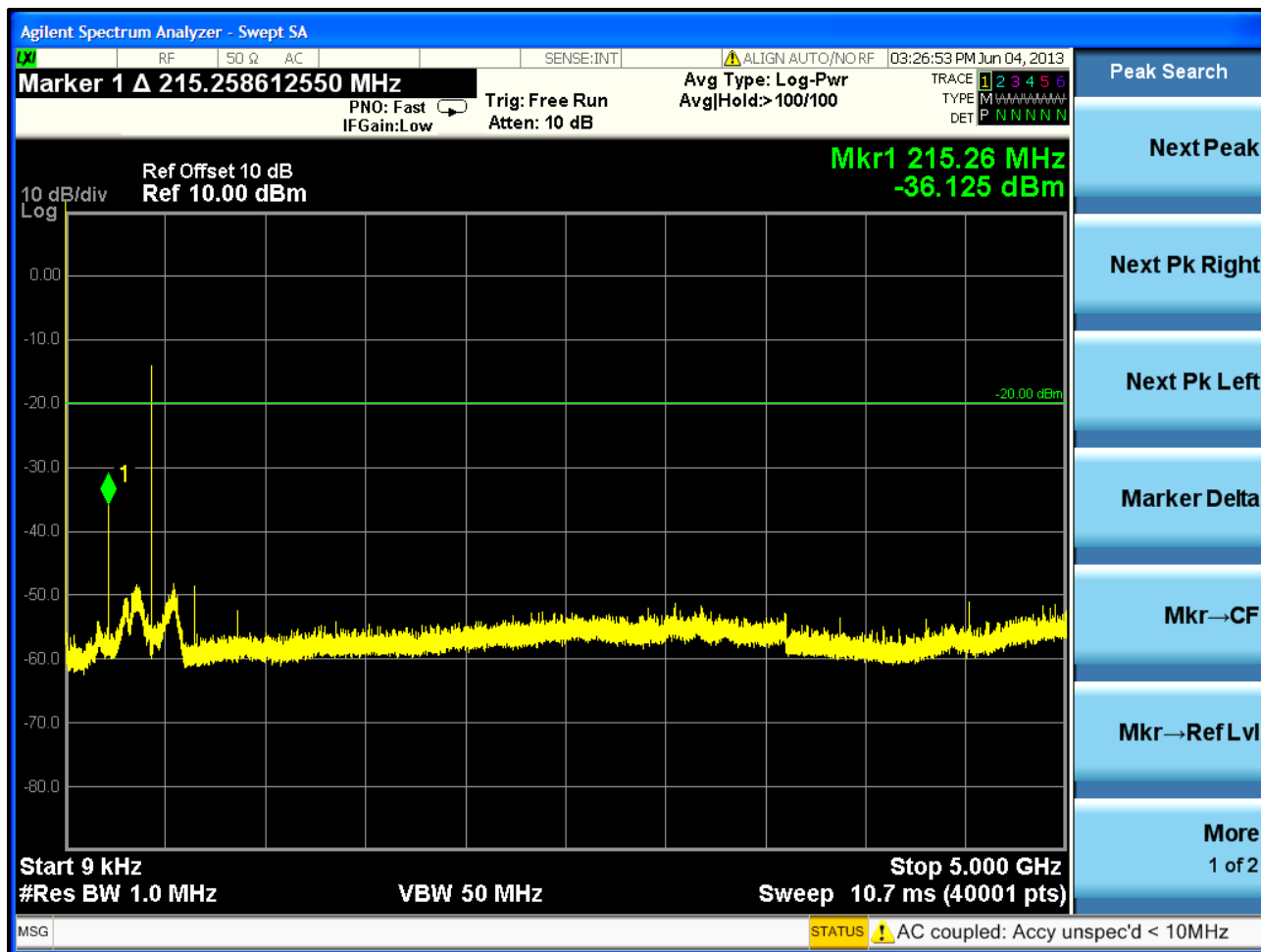

Plot 5-5: Spurious Emissions at Antenna Terminals – 450.0125 MHz

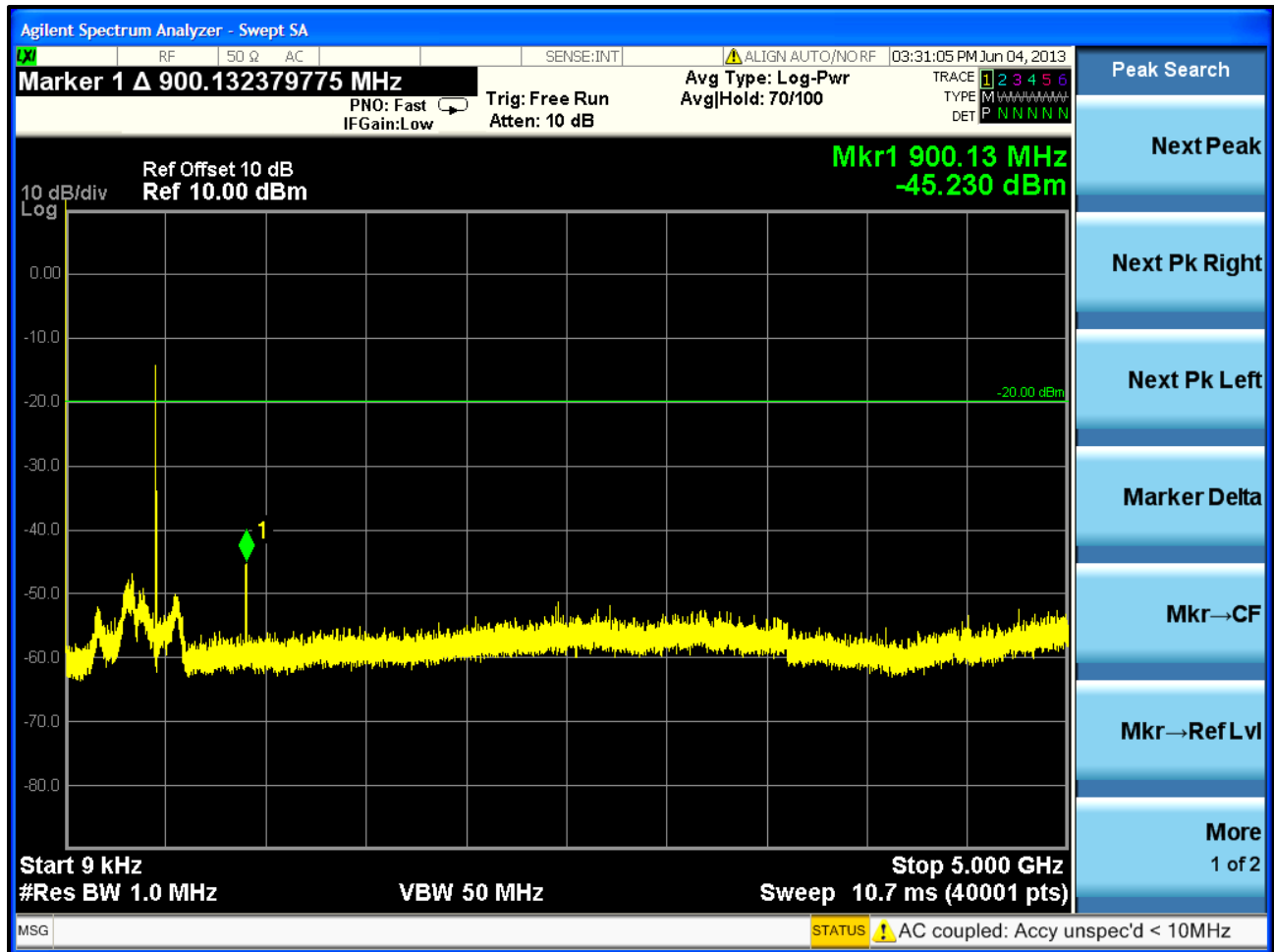

Plot 5-6: Spurious Emissions at Antenna Terminals – 454.0125 MHz

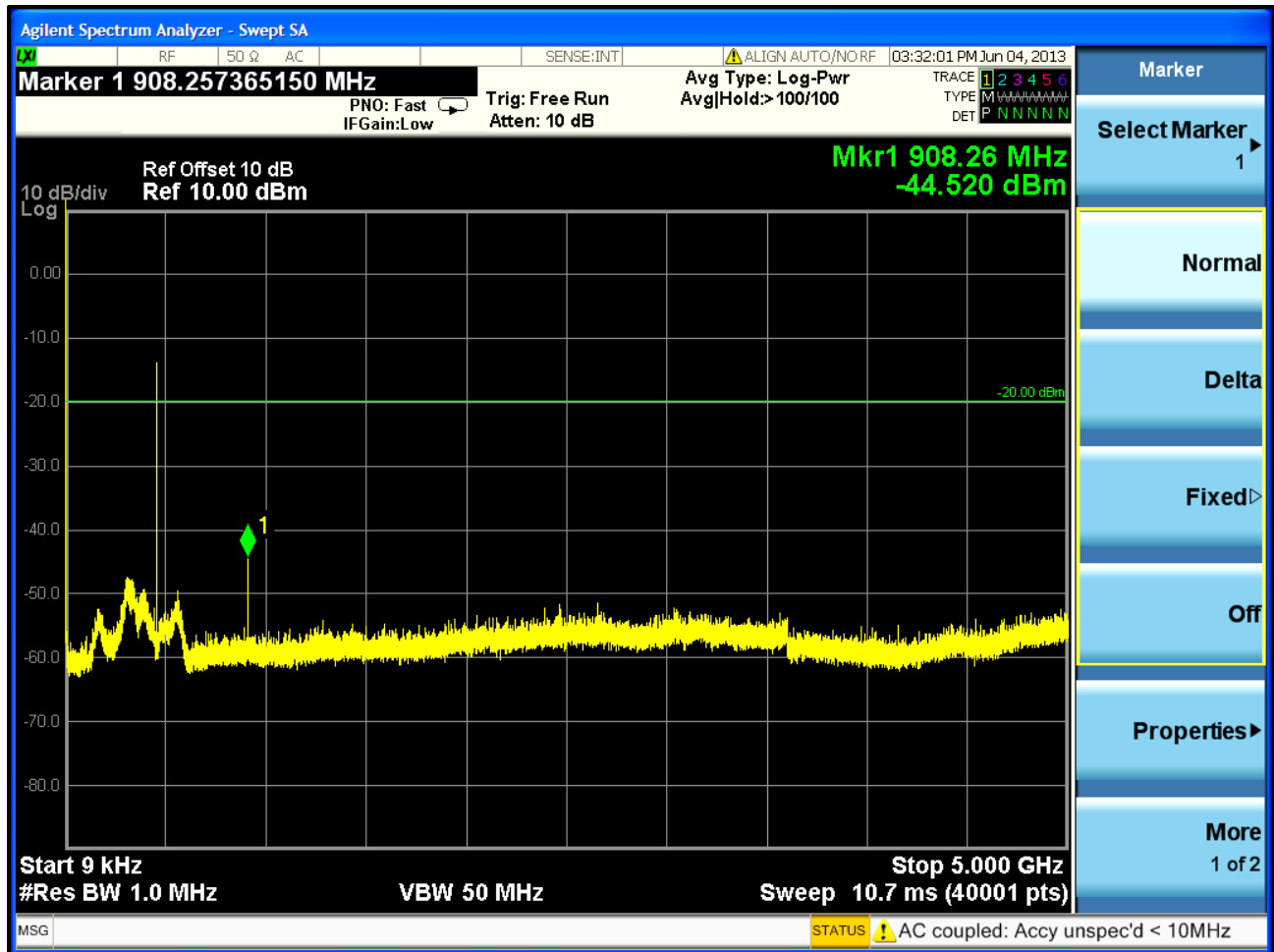

Plot 5-7: Spurious Emissions at Antenna Terminals – 456.0125 MHz

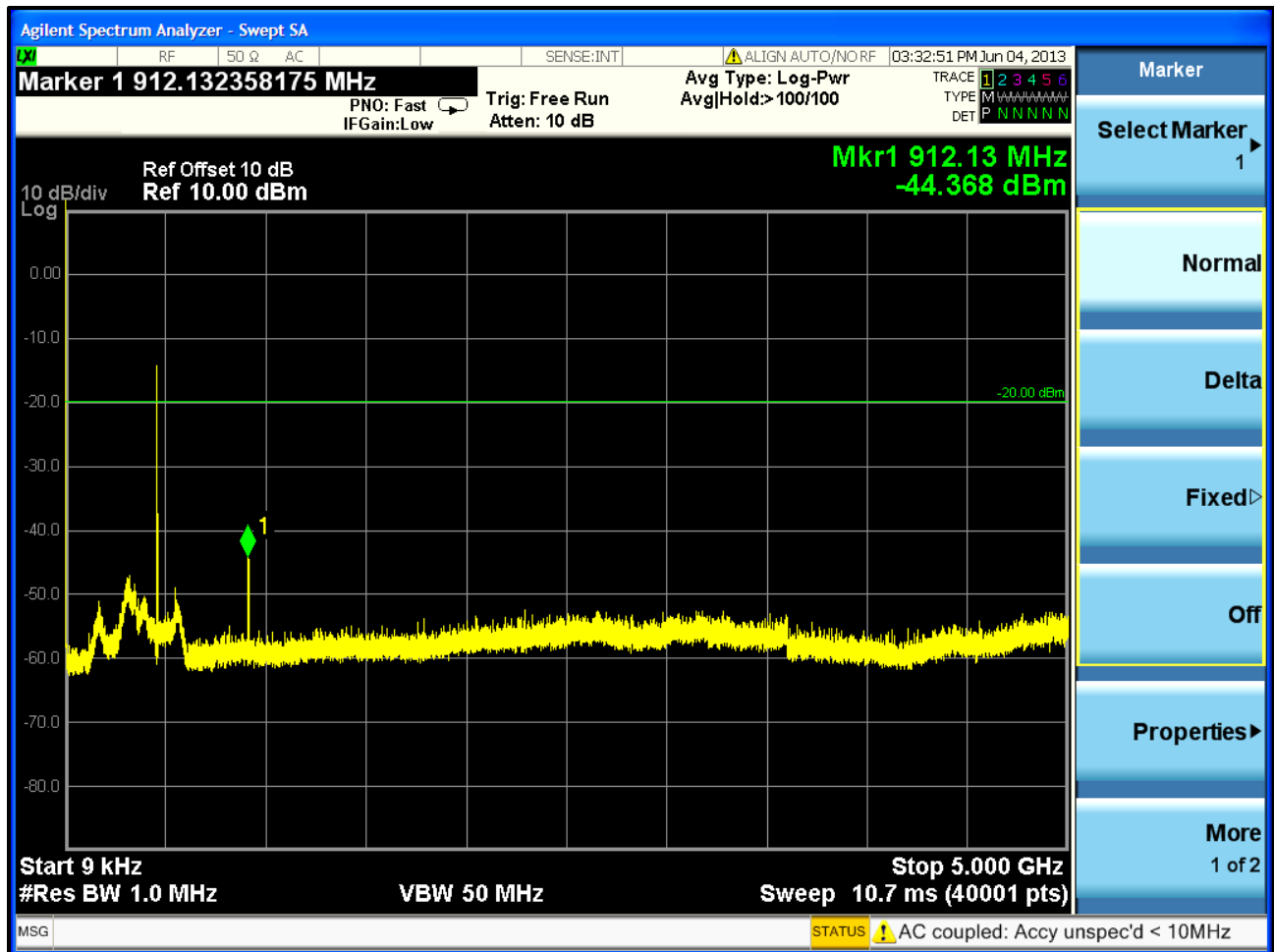

Plot 5-8: Spurious Emissions at Antenna Terminals – 458.9875 MHz

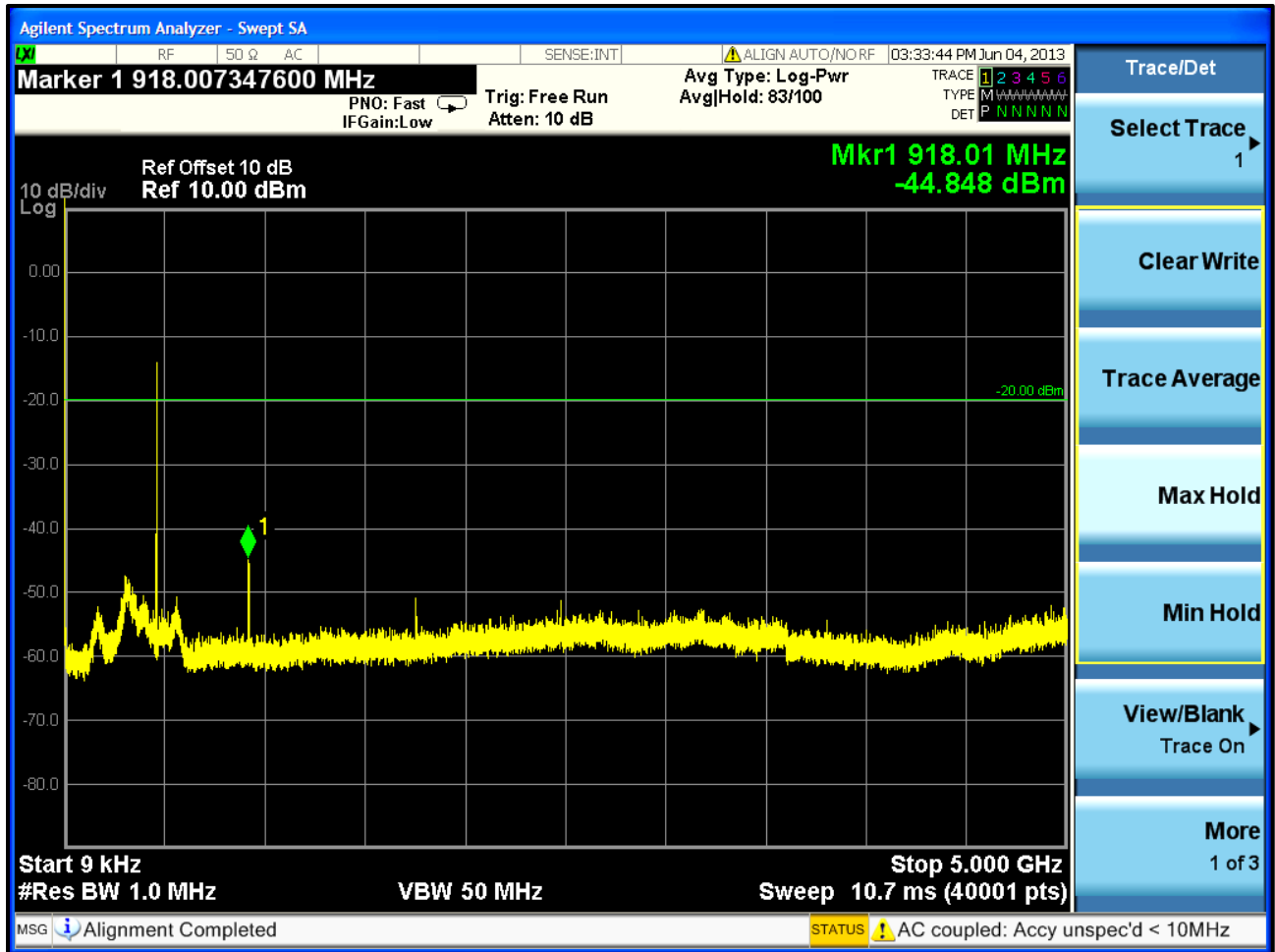

Plot 5-9: Spurious Emissions at Antenna Terminals – 459.0250 MHz

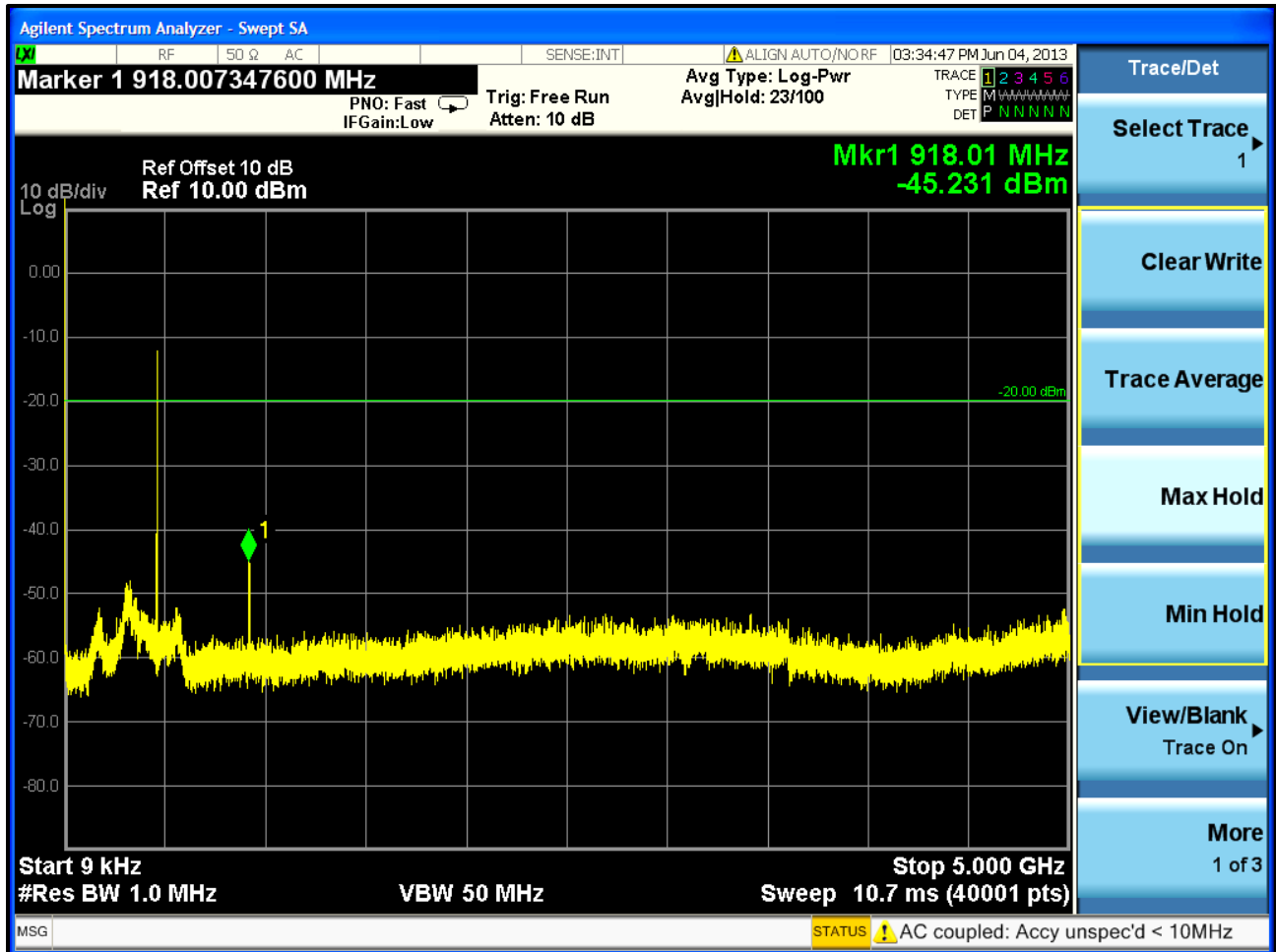

Plot 5-10: Spurious Emissions at Antenna Terminals – 459.9750 MHz

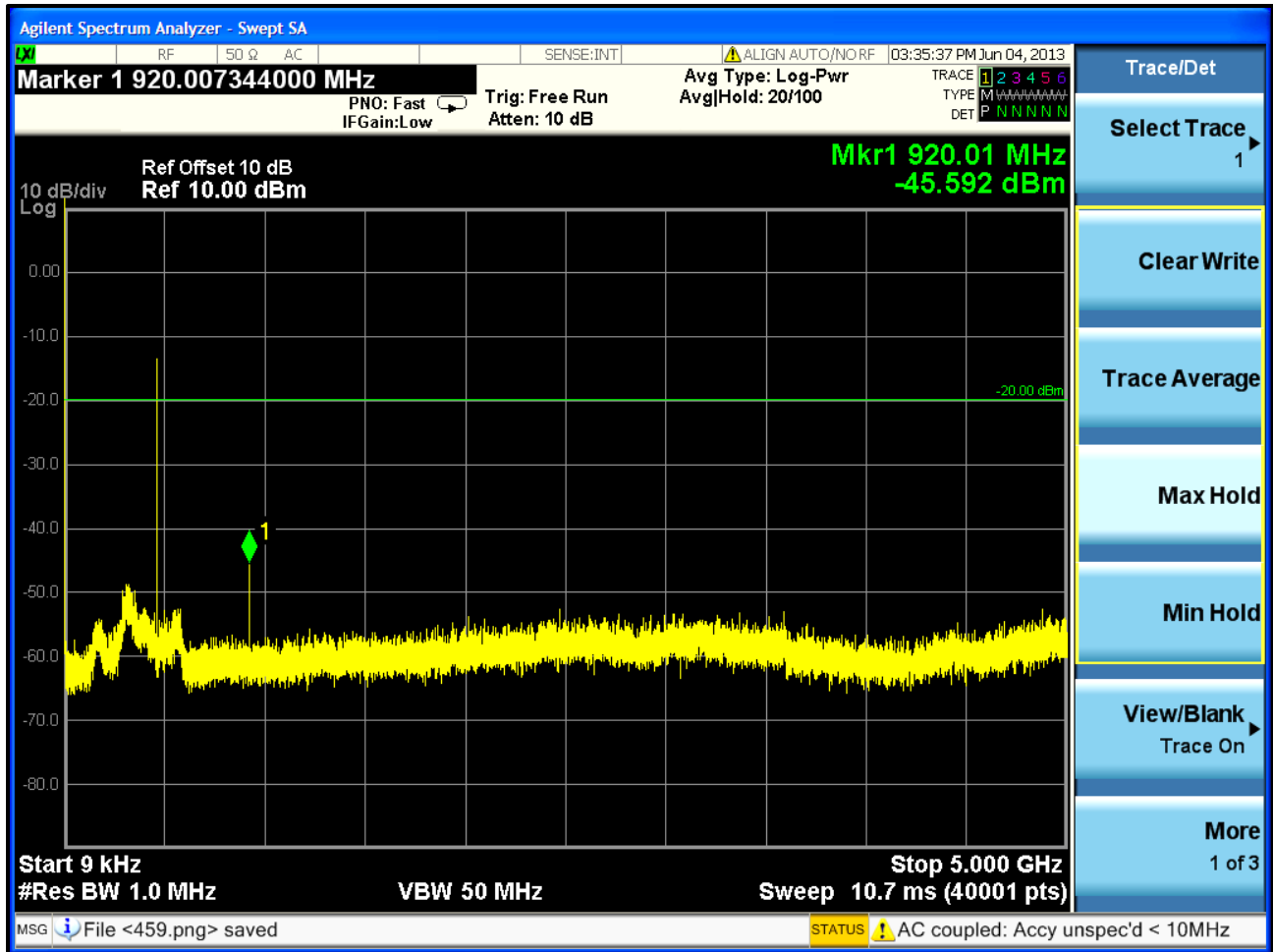

Rhein Tech Laboratories, Inc.
360 Herndon Parkway
Suite 1400
Herndon, VA20170
<http://www.rheintech.com>

Client: Harris Corporation
Model: XG-25P UHF-L
ID's: OWDTR-0141-E/3636B-0141
Standards: FCC Part 22, 80, 90/IC RSS-119
Report #: 2015075TNF

Table 5-1: Test Equipment Used For Testing Spurious Emissions

RTL Asset #	Manufacturer	Model	Part Type	Serial Number	Calibration Due Date
901583	Agilent Technologies	N9010A	EXA Signal Analyzer (10 Hz - 26.5 GHz)	MY5125084 6	4/16/14
900819	Weinschel Corp	2	10 dB Attenuator; 5 W	BF0830	3/18/14
901133	Par Electronics	400-512 (25W)	UHF Notch Filter	N/A	2/29/14

Test Personnel:



Daniel Baltzell
EMC Test Engineer

Signature

June 4, 2013
Date of Test

6 FCC Part 2.1053(a), 22.359, 80.211(f)(3), 90.210; IC RSS-119 5.5, 5.8.9.2: Radiated Emissions

6.1 Test Procedure

TIA-603-D 2010 Section 2.2.12

The device uses digital modulation modulated to its maximum extent using a pseudo-random data sequence. The spurious emissions levels were measured, and the device under test was replaced by a substitution antenna connected to a signal generator. This signal generator level was then corrected by subtracting the cable loss from the substitution antenna to the signal generator, and the gain of the antenna (dBi) was added to achieve the EIRP level, then converted from the corrected signal generator level (dBm) to dBc, and compared to the limit.

6.2 Test Data

Table 6-1: Field Strength of Spurious Radiation – 378.0125 MHz

Conducted Power 37.2 dBm; 5.2 W; Limit=50+10LogP=57.2 dBc

Frequency (MHz)	Spectrum Analyzer Level (dBuV)	Signal Generator Level (dBm)	Cable Loss to Transmit Antenna (dB)	Substitution Antenna Gain (dBi)	Corrected Signal Generator Level (dBc)	Margin (dB)
756.0250	51.7	-64.3	0.2	0.9	100.9	-43.7
1134.0375	55.8	-60.4	0.3	3.0	94.9	-37.7
1512.0500	53.9	-61.3	0.4	5.5	93.3	-36.1
1890.0625	60.3	-51.9	0.4	6.7	82.8	-25.6
2268.0750	51.1	-62.8	0.5	7.6	92.9	-35.7
2646.0875	54.8	-58.5	0.5	7.6	88.6	-31.4
3024.1000	54.1	-58.6	0.6	7.8	88.6	-31.4
3402.1125	53.3	-58.0	0.6	7.3	88.5	-31.3
3780.1250	49.4	-59.3	0.7	7.1	90.1	-32.9

Table 6-2: Field Strength of Spurious Radiation – 406.1125 MHz

Conducted Power 37.1 dBm; 5.1 W; Limit=50+10LogP=57.1 dBc

Frequency (MHz)	Spectrum Analyzer Level (dBuV)	Signal Generator Level (dBm)	Cable Loss to Transmit Antenna (dB)	Substitution Antenna Gain (dBi)	Corrected Signal Generator Level (dBc)	Margin (dB)
812.2250	62.2	-54.9	0.2	0.6	91.6	-34.5
1218.3375	54.2	-61.8	0.3	3.3	95.9	-38.8
1624.4500	50.0	-64.9	0.4	6.9	95.5	-38.4
2030.5625	59.6	-54.3	0.4	6.4	85.4	-28.3
2436.6750	55.5	-57.3	0.5	7.6	87.3	-30.2
2842.7875	48.6	-63.1	0.6	8.1	92.6	-35.5
3248.9000	50.0	-60.7	0.6	7.4	91.1	-34.0
3655.0125	47.6	-62	0.7	7.4	92.4	-35.3
4061.1250	51.5	-54.7	0.7	7.9	84.6	-27.5
812.2250	62.2	-54.9	0.2	0.6	91.6	-34.5

Table 6-3: Field Strength of Spurious Radiation – 418.0000 MHz

Conducted Power 37.2 dBm; 5.2 W; Limit=50+10LogP=57.2 dBc

Frequency (MHz)	Spectrum Analyzer Level (dBuV)	Signal Generator Level (dBm)	Cable Loss to Transmit Antenna (dB)	Substitution Antenna Gain (dBi)	Corrected Signal Generator Level (dBc)	Margin (dB)
836.0000	68.7	-48.7	0.2	0.7	85.4	-28.2
1254.0000	53.9	-62.0	0.3	3.7	95.8	-38.6
1672.0000	50.3	-64.5	0.4	7.2	94.8	-37.6
2090.0000	59.7	-54.0	0.4	6.4	85.3	-28.1
2508.0000	53.0	-59.6	0.5	7.6	89.7	-32.5
2926.0000	51.6	-59.9	0.6	8.1	89.6	-32.4
3344.0000	51.1	-60.7	0.6	7.3	91.2	-34.0
3762.0000	55.7	-54.8	0.7	7.2	85.5	-28.3
4180.0000	50.8	-55.5	0.7	8.5	84.9	-27.7
836.0000	68.7	-48.7	0.2	0.7	85.4	-28.2

Table 6-4: Field Strength of Spurious Radiation – 429.9875 MHz

Conducted Power 37.2 dBm; 5.2 W; Limit=50+10LogP=57.2 dBc

Frequency (MHz)	Spectrum Analyzer Level (dBuV)	Signal Generator Level (dBm)	Cable Loss to Transmit Antenna (dB)	Substitution Antenna Gain (dBi)	Corrected Signal Generator Level (dBc)	Margin (dB)
859.9750	70.1	-47.3	0.2	0.7	84.0	-26.8
1289.9625	53.5	-64.9	0.3	4.1	98.3	-41.1
1719.9500	50.4	-64.3	0.4	7.4	94.4	-37.2
2149.9375	60.7	-52.8	0.5	6.8	83.6	-26.4
2579.9250	56.7	-55.7	0.5	7.5	85.9	-28.7
3009.9125	52.6	-58.7	0.6	7.8	88.7	-31.5
3439.9000	47.8	-63.7	0.6	7.5	94.1	-36.9
3869.8875	54.0	-56.1	0.7	7.2	86.8	-29.6
4299.8750	43.1	-63.2	0.8	8.8	92.4	-35.2

Table 6-5: Field Strength of Spurious Radiation – 450.0125 MHz

Conducted Power 37.1 dBm; 5.1 W; Limit=50+10LogP=57.1 dBc

Frequency (MHz)	Spectrum Analyzer Level (dBuV)	Signal Generator Level (dBm)	Cable Loss to Transmit Antenna (dB)	Substitution Antenna Gain (dBi)	Corrected Signal Generator Level (dBc)	Margin (dB)
900.0250	72.4	-44.4	0.2	0.9	80.8	-23.7
1350.0375	52.1	-63.5	0.3	4.5	96.5	-39.4
1800.0500	57.5	-57	0.4	7.5	87.0	-29.9
2250.0625	57.6	-55.7	0.5	7.5	85.7	-28.6
2700.0750	55.0	-57.1	0.5	7.8	87.0	-29.9
3150.0875	48.9	-62	0.6	7.4	92.3	-35.2
3600.1000	54.2	-55.5	0.7	7.5	85.8	-28.7
4050.1125	46.1	-60.1	0.7	7.9	90.1	-33.0
4500.1250	37.6	-68.8	0.8	8.9	97.8	-40.7

Table 6-6: Field Strength of Spurious Radiation – 454.0125 MHz

Conducted Power 37.1 dBm; 5.1 W; Limit=50+10LogP=57.1 dBc

Frequency (MHz)	Spectrum Analyzer Level (dBuV)	Signal Generator Level (dBm)	Cable Loss to Transmit Antenna (dB)	Substitution Antenna Gain (dBi)	Corrected Signal Generator Level (dBc)	Margin (dB)
908.0250	70.8	-46.0	0.3	0.9	82.4	-25.3
1362.0375	54.8	-60.8	0.3	4.5	93.7	-36.6
1816.0500	58.6	-55.8	0.4	7.4	85.9	-28.8
2270.0625	56.4	-56.8	0.5	7.6	86.7	-29.6
2724.0750	54.2	-57.8	0.5	7.9	87.6	-30.5
3178.0875	48.4	-62.5	0.6	7.4	92.8	-35.7
3632.1000	53.7	-57.2	0.7	7.4	87.5	-30.4
4086.1125	48.2	-58.3	0.7	8.0	88.1	-31.0
4540.1250	37.7	-69.0	0.8	8.9	98.0	-40.9

Table 6-7: Field Strength of Spurious Radiation – 456.0125 MHz

Conducted Power 37.1 dBm; 5.1 W; Limit=50+10LogP=57.1 dBc

Frequency (MHz)	Spectrum Analyzer Level (dBuV)	Signal Generator Level (dBm)	Cable Loss to Transmit Antenna (dB)	Substitution Antenna Gain (dBi)	Corrected Signal Generator Level (dBc)	Margin (dB)
912.0250	70.6	-46.2	0.3	0.9	82.6	-25.5
1368.0375	49.4	-66.2	0.3	4.6	99.1	-42.0
1824.0500	55.1	-59.3	0.4	7.3	89.5	-32.4
2280.0625	56.6	-56.6	0.5	7.7	86.5	-29.4
2736.0750	53.6	-58.4	0.5	7.9	88.1	-31.0
3192.0875	49.1	-61.7	0.6	7.4	92.0	-34.9
3648.1000	46.0	-64.8	0.7	7.4	95.2	-38.1
4104.1125	45.6	-60.9	0.7	8.1	90.6	-33.5
4560.1250	37.6	-68.9	0.8	8.9	97.9	-40.8

Table 6-8: Field Strength of Spurious Radiation – 458.9875 MHz

Conducted Power 37.1 dBm; 5.1 W; Limit=50+10LogP=57.1 dBc

Frequency (MHz)	Spectrum Analyzer Level (dBuV)	Signal Generator Level (dBm)	Cable Loss to Transmit Antenna (dB)	Substitution Antenna Gain (dBi)	Corrected Signal Generator Level (dBc)	Margin (dB)
917.9750	67.1	-49.7	0.3	1.0	86.1	-29.0
1376.9625	54.3	-61.3	0.3	4.6	94.1	-37.0
1835.9500	54.2	-60.2	0.4	7.2	90.5	-33.4
2294.9375	55.6	-57.6	0.5	7.7	87.4	-30.3
2753.9250	53.1	-58.9	0.5	8.0	88.6	-31.5
3212.9125	48.1	-62.7	0.6	7.4	93.0	-35.9
3671.9000	45.3	-65.5	0.7	7.3	95.9	-38.8
4130.8875	43.9	-62.7	0.7	8.3	92.3	-35.2
4589.8750	38.9	-67.9	0.8	9.0	96.8	-39.7

Table 6-9: Field Strength of Spurious Radiation – 459.0250 MHz

Conducted Power 37.1 dBm; 5.1 W; Limit=50+10LogP=57.1 dBc

Frequency (MHz)	Spectrum Analyzer Level (dBuV)	Signal Generator Level (dBm)	Cable Loss to Transmit Antenna (dB)	Substitution Antenna Gain (dBi)	Corrected Signal Generator Level (dBc)	Margin (dB)
918.0500	67.5	-49.3	0.3	1.0	85.7	-28.6
1377.0750	49.8	-65.8	0.3	4.6	98.6	-41.5
1836.1000	54.7	-59.7	0.4	7.2	90.0	-32.9
2295.1250	55.1	-58.1	0.5	7.7	87.9	-30.8
2754.1500	52.9	-59.1	0.5	8.0	88.8	-31.7
3213.1750	48.3	-63.9	0.6	7.4	94.2	-37.1
3672.2000	50.7	-60.1	0.7	7.3	90.5	-33.4
4131.2250	44.2	-62.4	0.7	8.3	92.0	-34.9
4590.2500	37.4	-69.4	0.8	9.0	98.3	-41.2

Table 6-10: Field Strength of Spurious Radiation – 459.9750 MHz

Conducted Power 37.2 dBm; 5.2 W; Limit=50+10LogP=57.2 dBc

Frequency (MHz)	Spectrum Analyzer Level (dBuV)	Signal Generator Level (dBm)	Cable Loss to Transmit Antenna (dB)	Substitution Antenna Gain (dBi)	Corrected Signal Generator Level (dBc)	Margin (dB)
919.9500	66.2	-50.6	0.3	1.0	87.1	-29.9
1379.9250	52.8	-62.8	0.3	4.6	95.7	-38.5
1839.9000	54.8	-59.6	0.4	7.2	90.1	-32.9
2299.8750	55.7	-57.5	0.5	7.7	87.4	-30.2
2759.8500	51.9	-60.0	0.5	8.0	89.8	-32.6
3219.8250	48.4	-62.3	0.6	7.4	92.7	-35.5
3679.8000	50.8	-58.7	0.7	7.3	89.2	-32.0
4139.7750	41.6	-64.7	0.7	8.3	94.3	-37.1
4599.7500	38.1	-68.4	0.8	9.0	97.4	-40.2

Table 6-11: Field Strength of Spurious Radiation – 469.9875 MHz

Conducted Power 37.2 dBm; 5.2 W; Limit=50+10LogP=57.2 dBc

Frequency (MHz)	Spectrum Analyzer Level (dBuV)	Signal Generator Level (dBm)	Cable Loss to Transmit Antenna (dB)	Substitution Antenna Gain (dBi)	Corrected Signal Generator Level (dBc)	Margin (dB)
939.9750	62.2	-54.5	0.3	1.1	90.8	-33.6
1409.9625	51.7	-63.8	0.3	4.8	96.5	-39.3
1879.9500	57.3	-57	0.4	6.8	87.8	-30.6
2349.9375	55.6	-57.4	0.5	7.7	87.4	-30.2
2819.9250	49.9	-61.9	0.6	8.1	91.5	-34.3
3289.9125	48.5	-62.1	0.6	7.3	92.6	-35.4
3759.9000	50.8	-58.5	0.7	7.2	89.2	-32.0
4229.8875	40.8	-65.8	0.8	8.7	95.1	-37.9
4699.8750	40.4	-66.4	0.8	9.1	95.3	-38.1

Table 6-12: Test Equipment Used For Testing Field Strength of Spurious Radiation

RTL Asset #	Manufacturer	Model	Part Type	Serial Number	Calibration Due Date
900932	Hewlett Packard	8449B OPT H02	Preamplifier (1 - 26.5 GHz)	3008A00505	8/10/13
900878	Rhein Tech Laboratories	AM3-1197-0005	3 meter antenna mast, polarizing	OATS1	N/A
901592	Insulated Wire Inc.	KPS-1503-3600-KPR	SMK RF Cables 20'	NA	8/16/13
901593	Insulated Wire Inc.	KPS-1503-360-KPR	SMK RF Cables 36"	NA	8/16/13
901594	Insulated Wire Inc.	KPS-1503-360-KPR	SMK RF Cables 36"	NA	8/16/13
901242	Rhein Tech Laboratories	WRT-000-0003	Wood rotating table	N/A	N/A
900791	Chase	CBL6111B	Bilog Antenna (30 MHz – 2000 MHz)	N/A	2/2/14
900321	EMCO	3161-03	Horn Antennas (4 – 8 GHz)	9508-1020	4/19/14
900772	EMCO	3161-02	Horn Antenna (2 - 4 GHz)	9804-1044	4/19/14
900928	Hewlett Packard	83752A	Synthesized Sweeper, 0.01 to 20 GHz	3610A00866	3/20/15
900913	Hewlett Packard	85462A	EMI Receiver RF Section (9 kHz – 6.5 GHz)	3325A00159	8/2/13
900914	Hewlett Packard	85460A	RF Filter Section, (100 kHz - 6.5 GHz)	3330A00107	8/2/13
900905	Rhein Tech Laboratories	PR-1040	Amplifier (20 MHz - 2 GHz)	900905	8/20/13

Test Personnel:

Daniel Baltzell
 Test Engineer

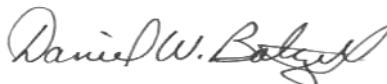

Signature

June 6, 2013
 Date of Tests

7 FCC Part 2.1049(c)(1), 22.359(b), 80.205, 80.211, 90.210; IC RSS-119 5.5, 5.8: Bandwidths/Masks

Occupied Bandwidth - Compliance with the Emission Masks

FCC 22.359(a) *Out of band emissions*. The power of any emission outside of the authorized operating frequency ranges must be attenuated below the transmitting power (P) by a factor of at least $43 + 10 \log (P)$ dB.

(b) Measurement procedure: In the 60 kHz bands immediately outside and adjacent to the authorized frequency range or channel, a resolution bandwidth of at least one percent of the emission bandwidth of the fundamental emission of the transmitter may be employed. A narrower resolution bandwidth is permitted in all cases to improve measurement accuracy provided the measured power is integrated over the full required measurement bandwidth (i.e., 30 kHz or 1 percent of emission bandwidth, as specified). The emission bandwidth is defined as the width of the signal between two points, one below the carrier center frequency and one above the carrier center frequency, outside of which all emissions are attenuated at least 26 dB below the transmitter power.

7.1 Test Procedure

TIA-603-D 2010 Section 2.2.11

Notes: FCC 90.210, RSS-119 and TIA-102.CCAB October 2011 section 3.2.5.1 all specify mask D

Device with digital modulation: Modulated to its maximum extent using a pseudo-random data sequence.

Applicable Emission Masks		
Frequency Band (MHz)	Mask for Equipment With Audio Low Pass Filter	Mask for Equipment Without Audio Low Pass Filter
Below 25 ¹	A or B	A or C
25–50.....	B	C
72–76.....	B	C
150–174 ²	B, D, or E	C, D, or E
150 Paging-only	B	C
220–222	F	F
421–512 ²	B, D, or E	C, D, or E
450 Paging-only	B	G
806–809/851–854	B	H
809–824/854–869 ³	B	G
896–901/935–940	I	J
902–928	K	K
929–930	B	G
4940–4990 MHz	L or M	L or M
5850–5925 ⁴		
All other bands	B	C

¹ Equipment using single sideband J3E emission must meet the requirements of Emission Mask A. Equipment using other emissions must meet the requirements of Emission Mask B or C, as applicable.

² Equipment designed to operate with a 25 kHz channel bandwidth must meet the requirements of Emission Mask B or C, as applicable. Equipment designed to operate with a 12.5 kHz channel bandwidth must meet the requirements of Emission Mask D, and equipment designed to operate with a 6.25 kHz channel bandwidth must meet the requirements of Emission Mask E.

³ Equipment used in this licensed to EA or non-EA systems shall comply with the emission mask provisions of §90.691.

⁴ DSRCS Roadside Unit equipment in the 5850–5925 MHz band is governed under subpart M of this part.

7.2 Test Data

Plot 7-1: Occupied Bandwidth – 450.0125 MHz; Analog (FCC Part 22)

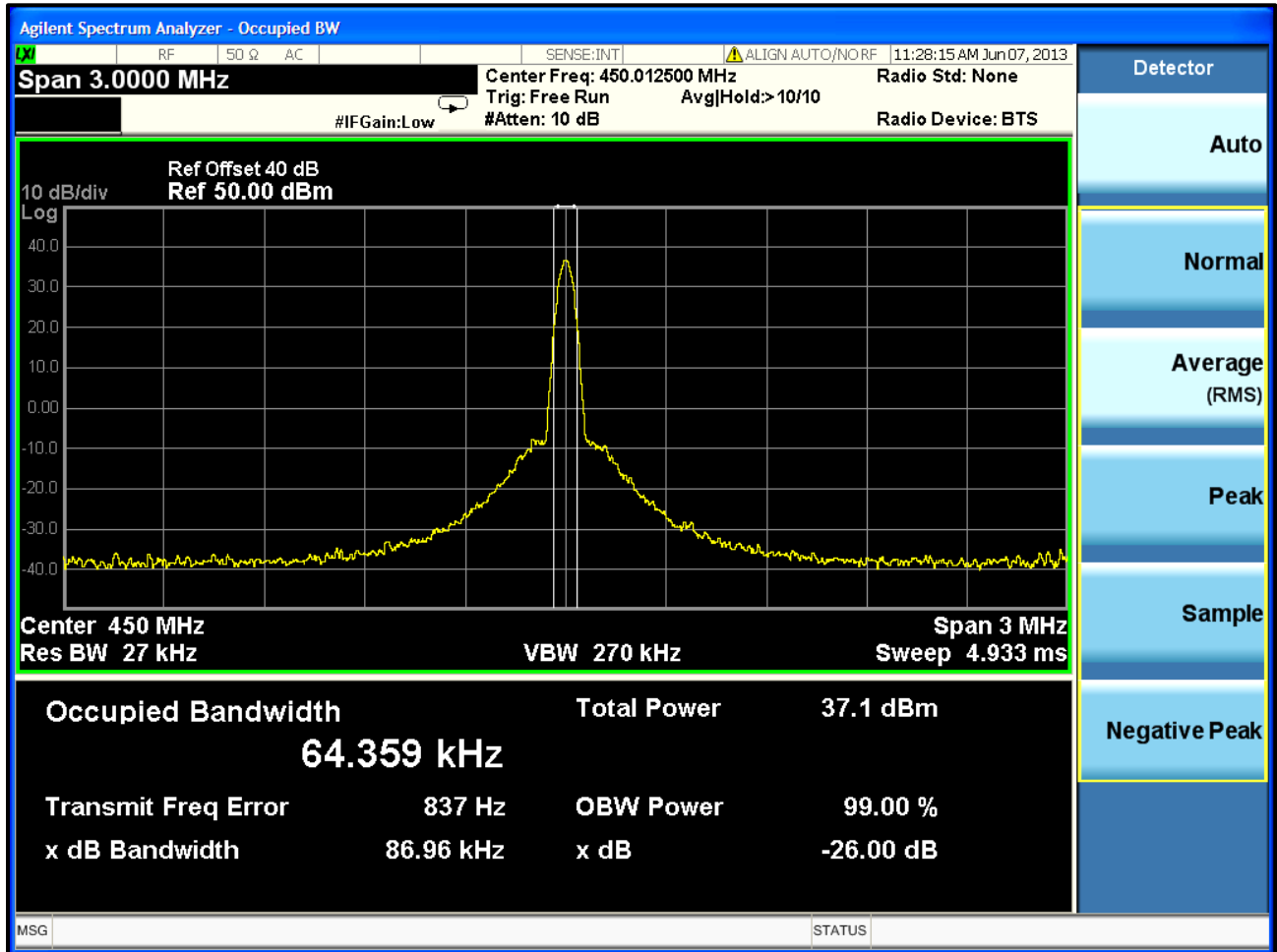

Plot 7-2: Occupied Bandwidth – 450.01 MHz; Mask; (FCC Part 22)

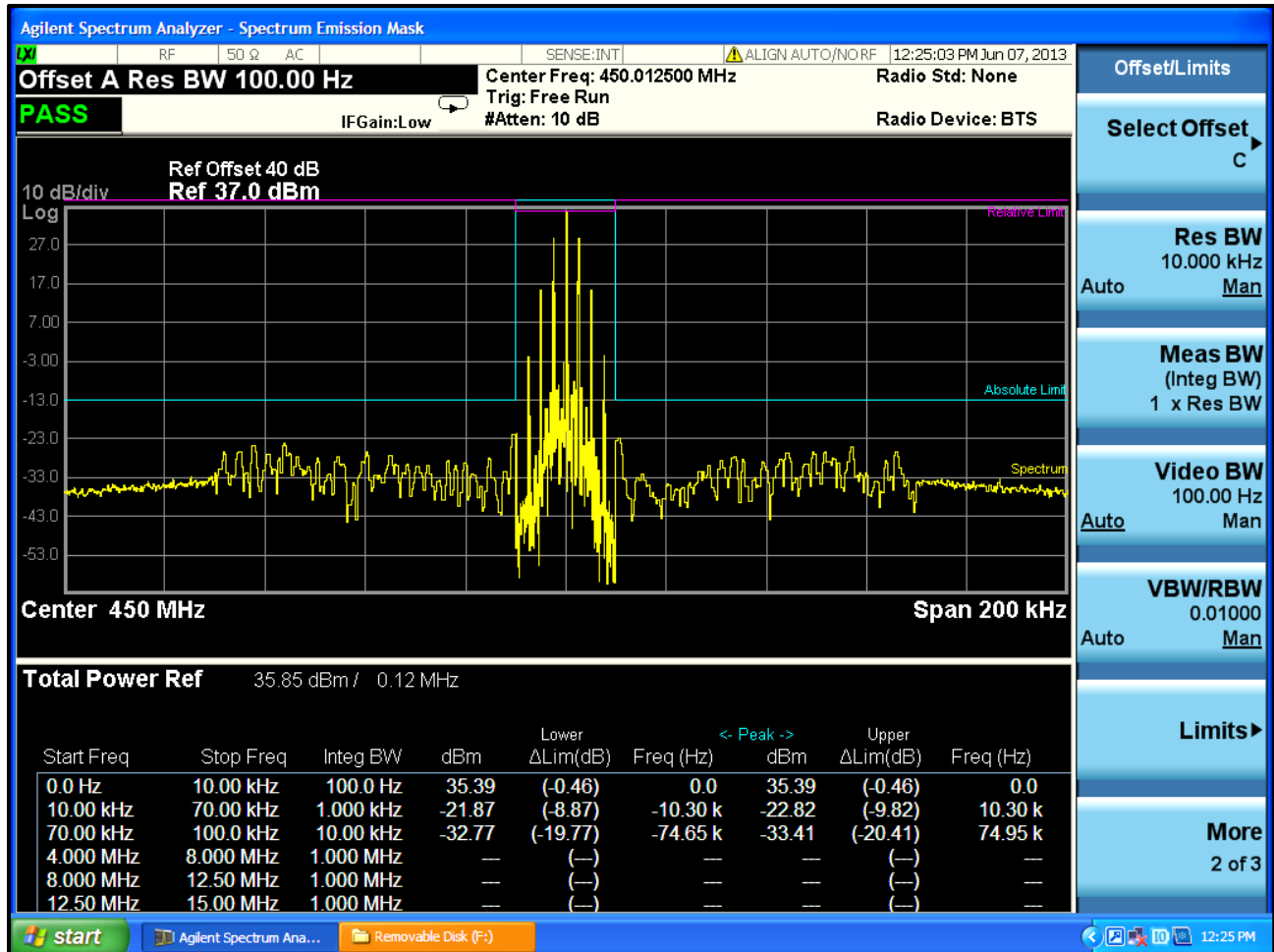

Plot 7-3: Occupied Bandwidth – 378.0125 MHz; Narrowband Analog; Mask D

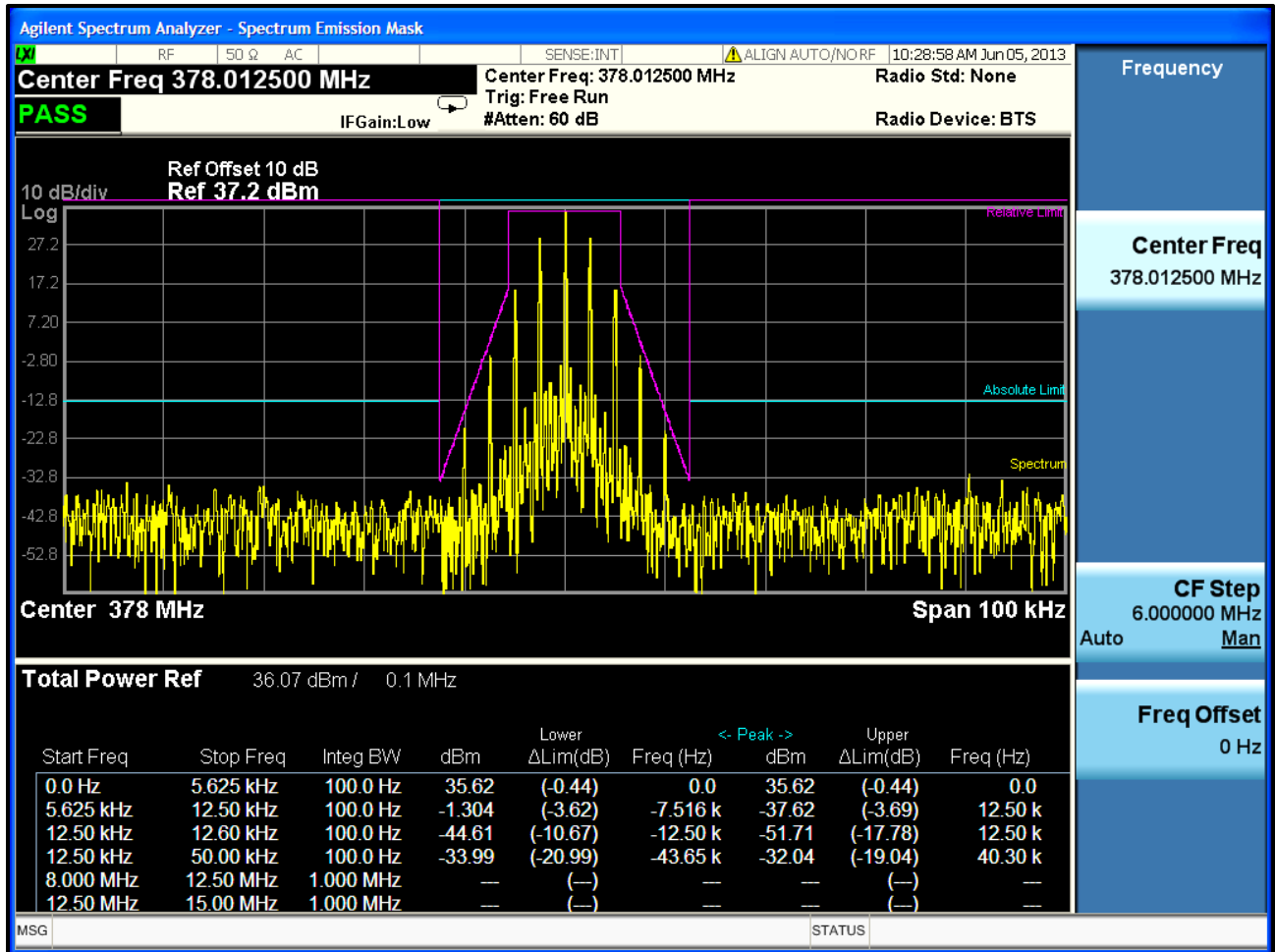

Plot 7-4: Occupied Bandwidth – 406.1125 MHz; Narrowband Analog; Mask D

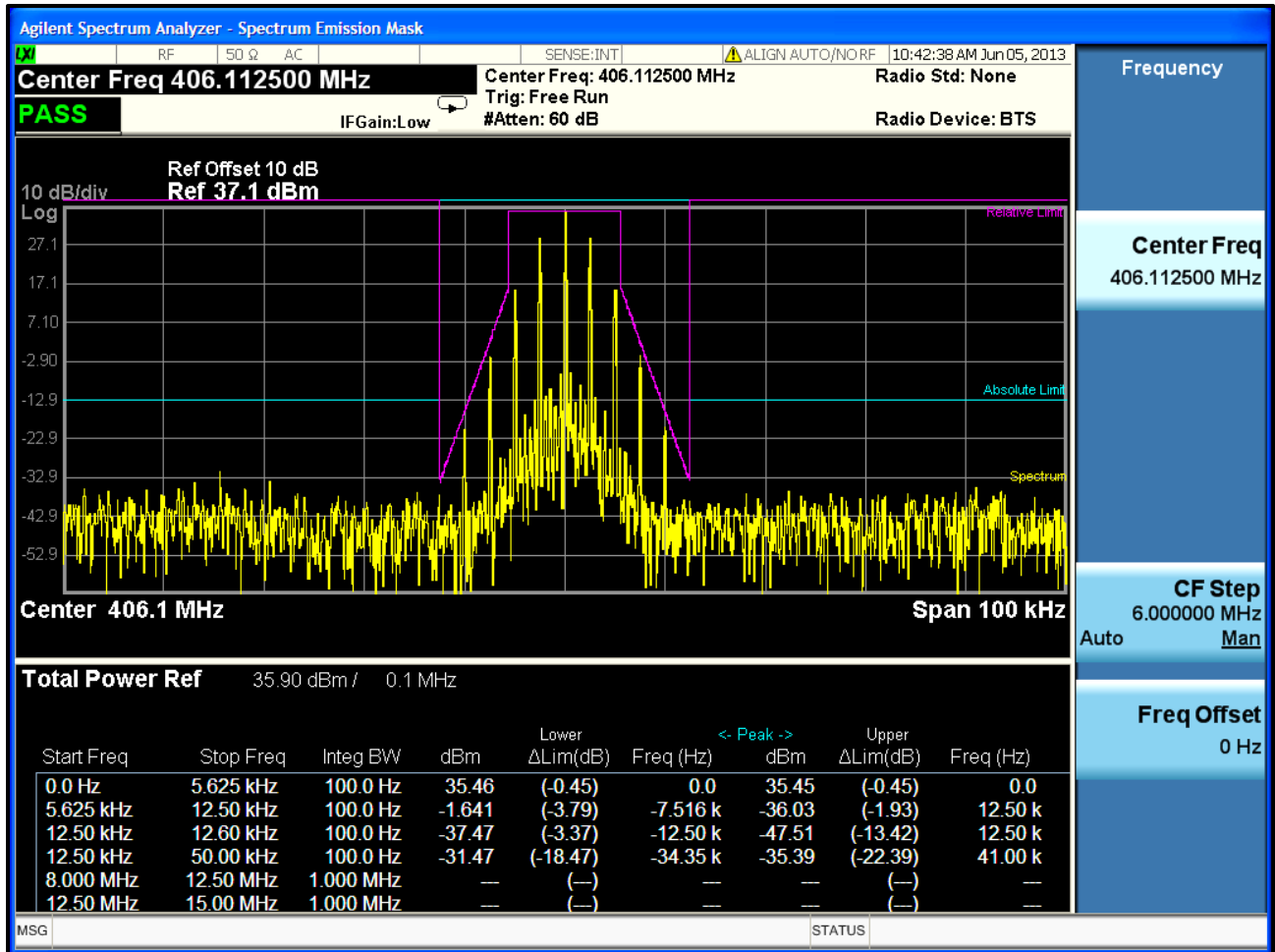

Plot 7-5: Occupied Bandwidth – 418.0000 MHz; Narrowband Analog; Mask D

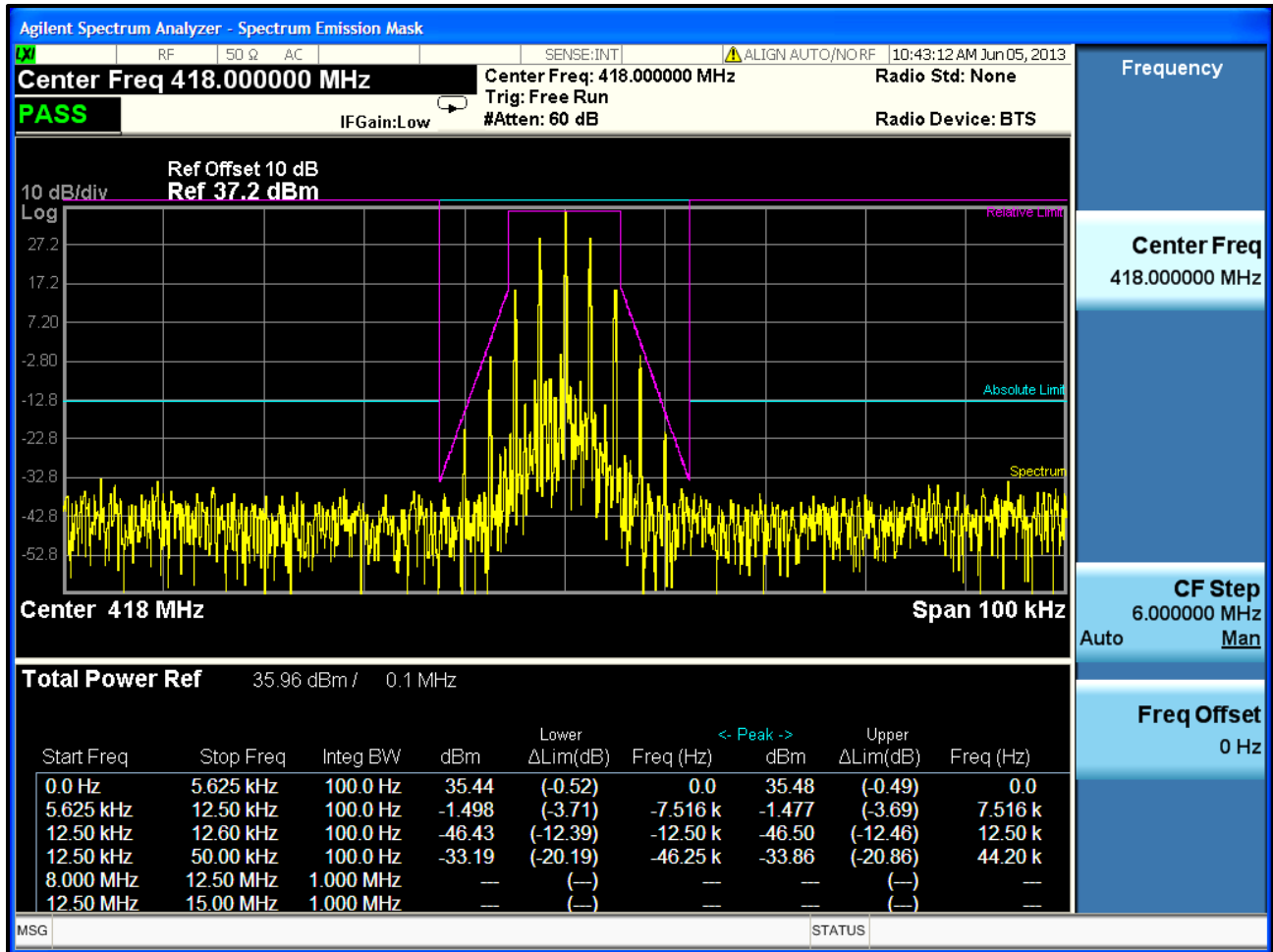

Plot 7-6: Occupied Bandwidth – 429.9875 MHz; Narrowband Analog; Mask D

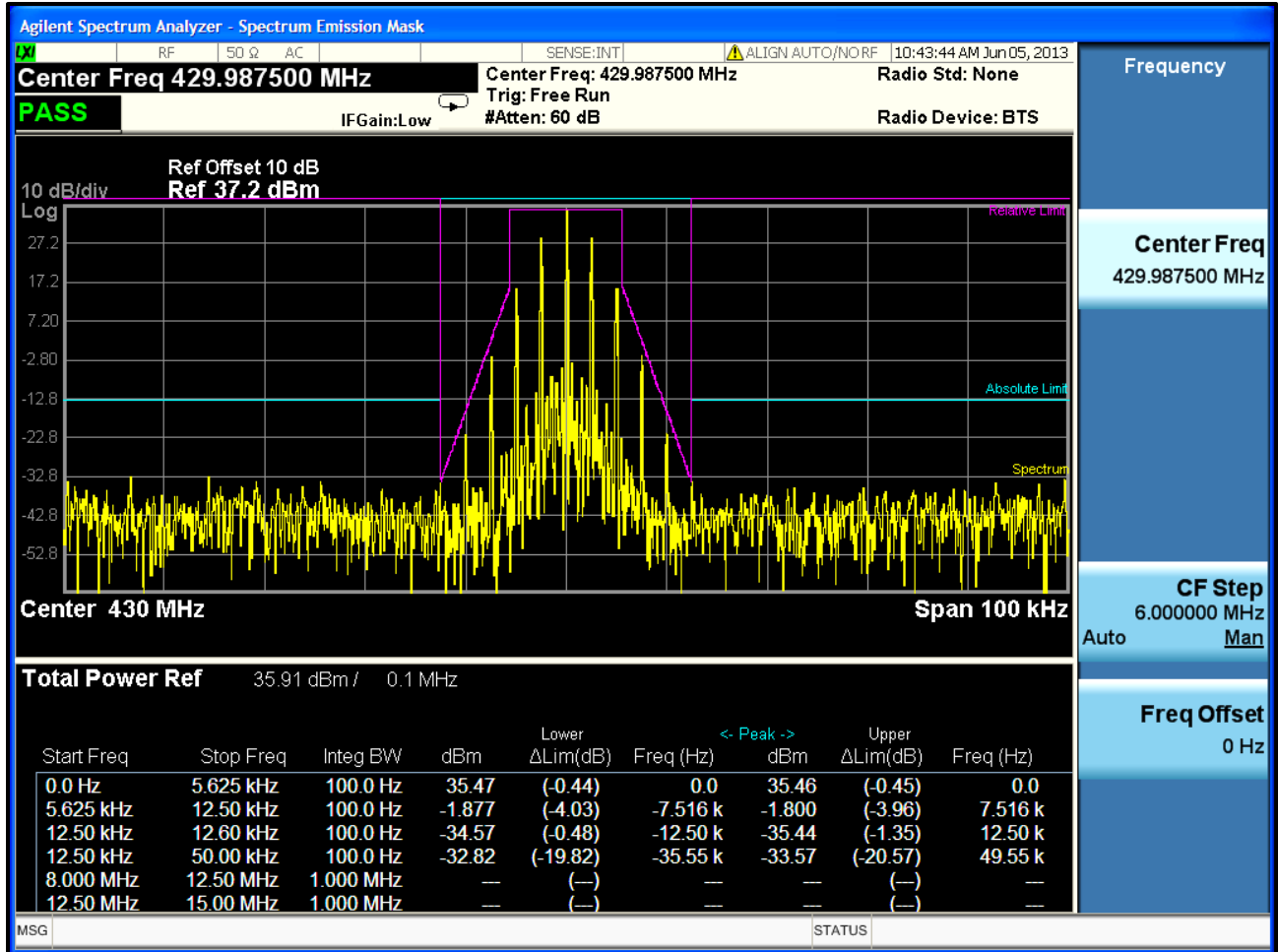

Plot 7-7: Occupied Bandwidth – 450.0125 MHz; Narrowband Analog; Mask D

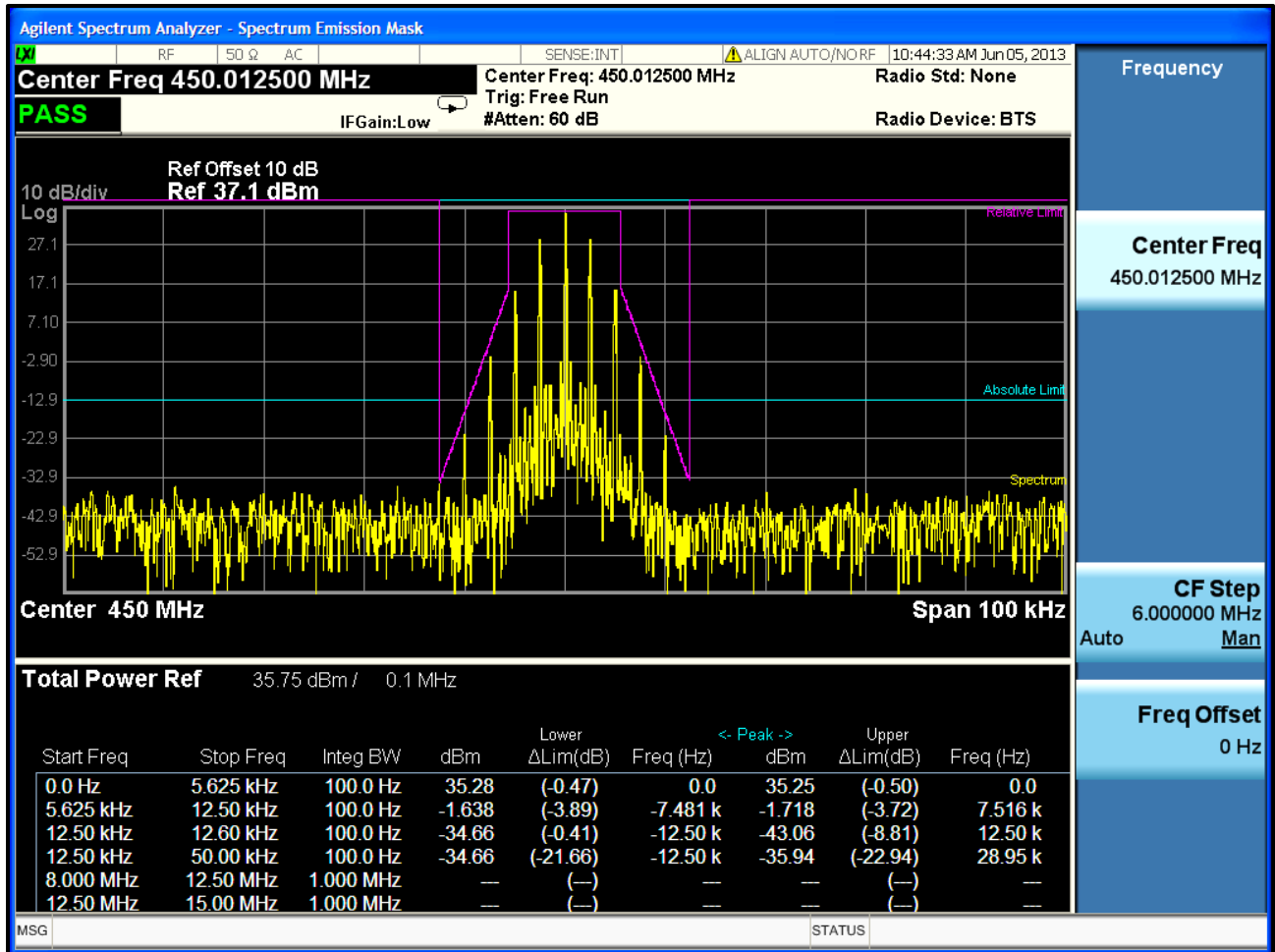

Plot 7-8: Occupied Bandwidth – 454.0125 MHz; Narrowband Analog; Mask D

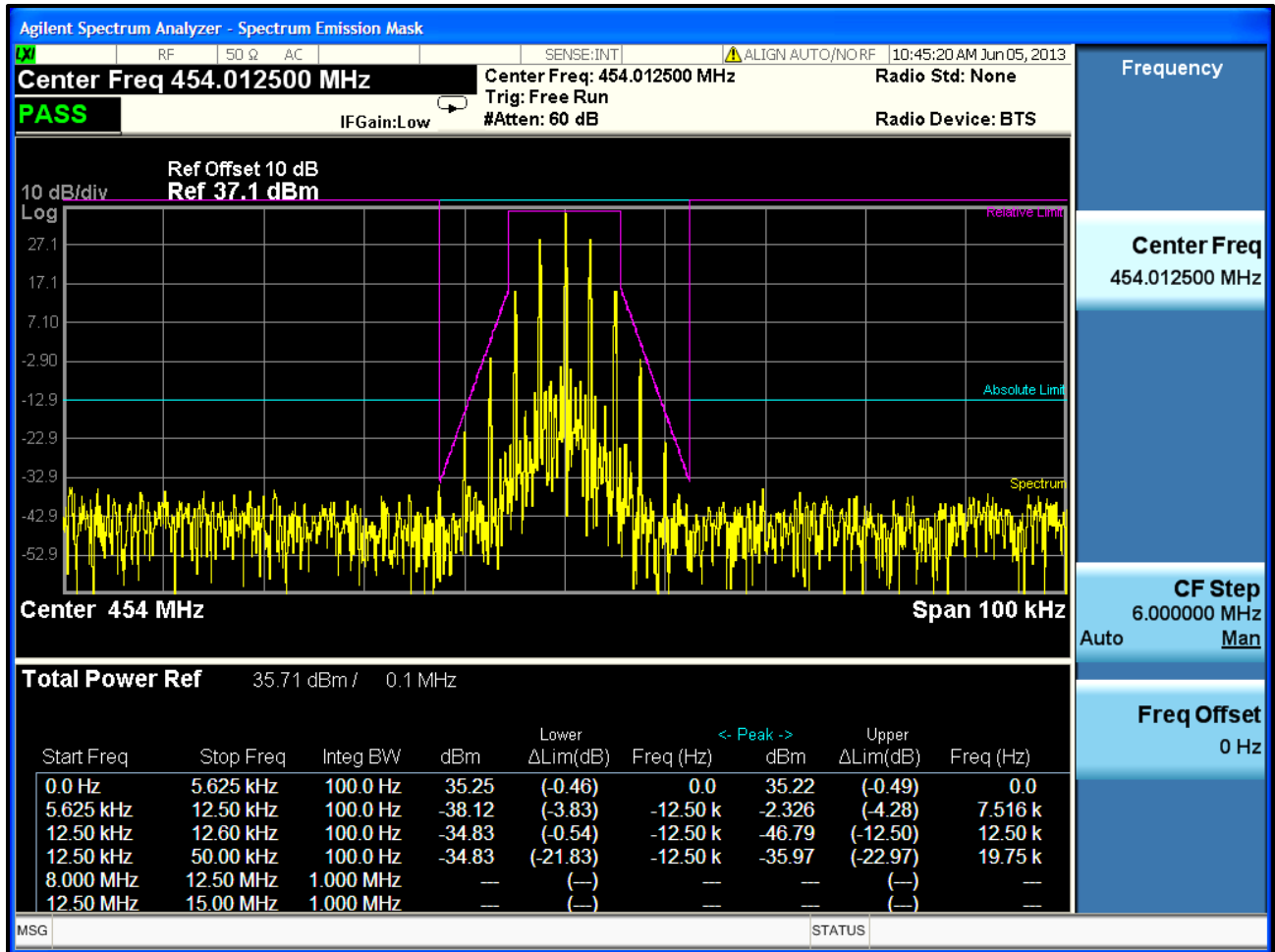

Plot 7-9: Occupied Bandwidth – 456.0125 MHz; Narrowband Analog; Mask D

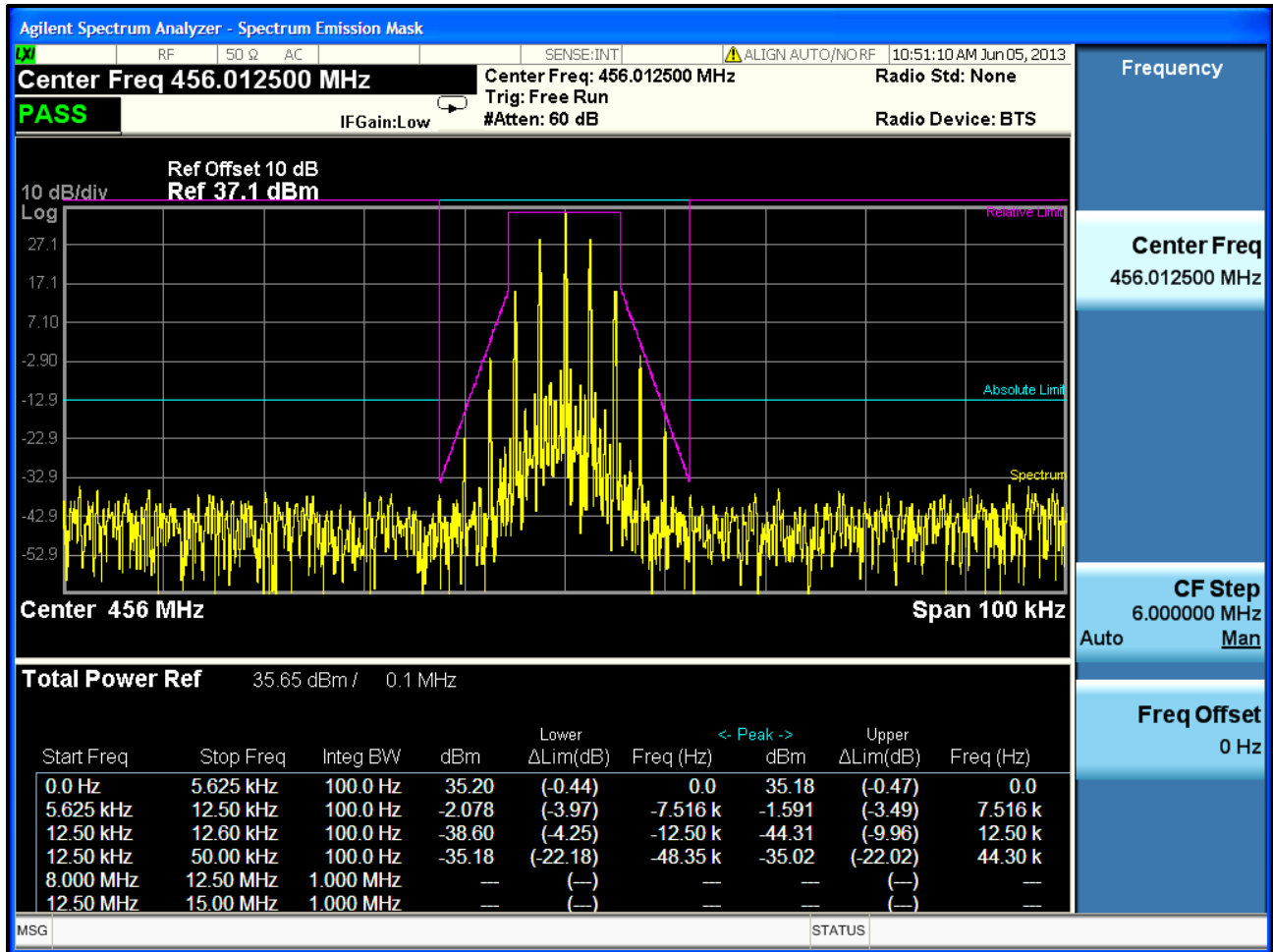

Plot 7-10: Occupied Bandwidth – 458.9875 MHz; Narrowband Analog; Mask D

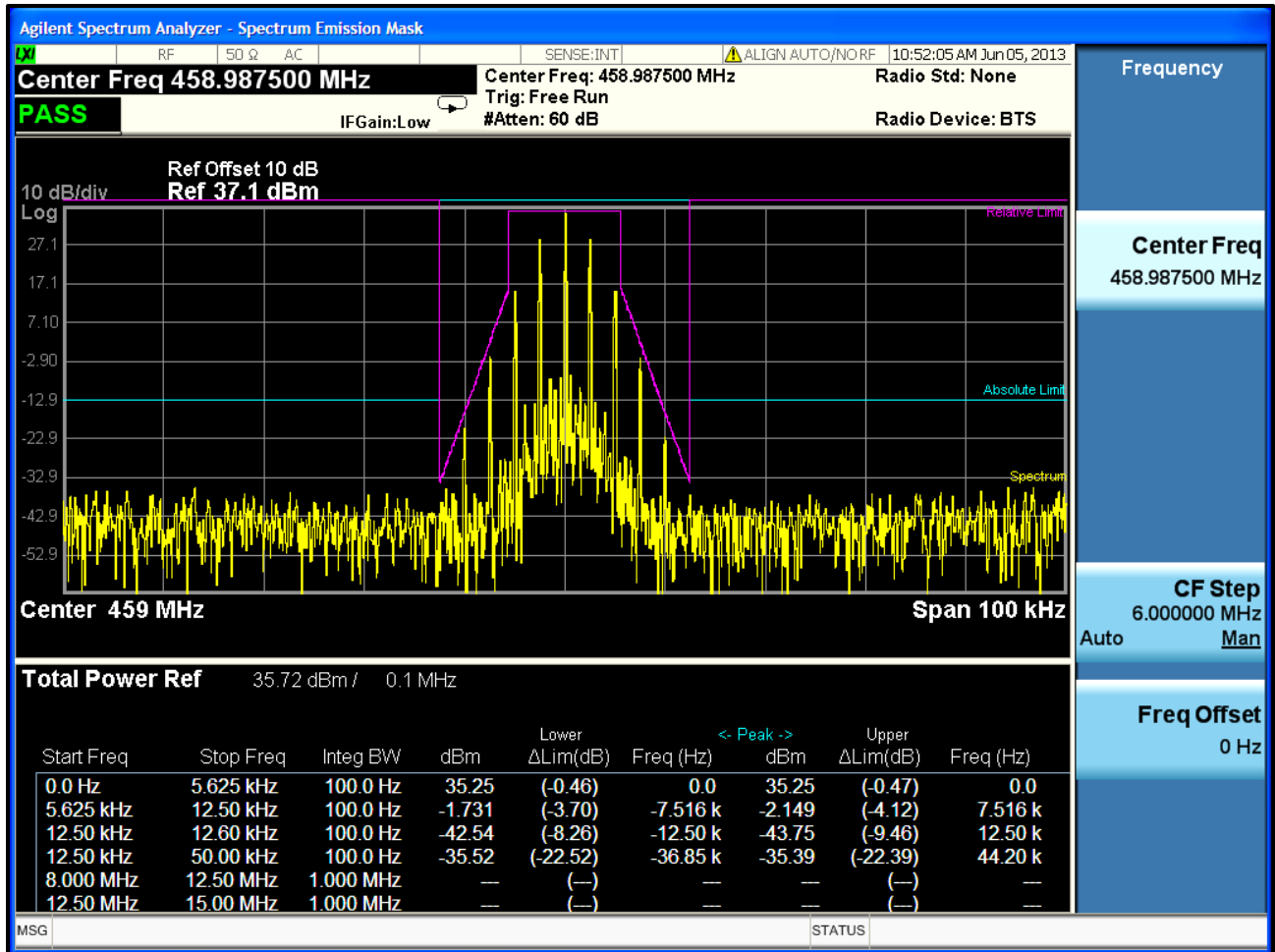

Plot 7-11: Occupied Bandwidth – 459.0250 MHz; Narrowband Analog; Mask D

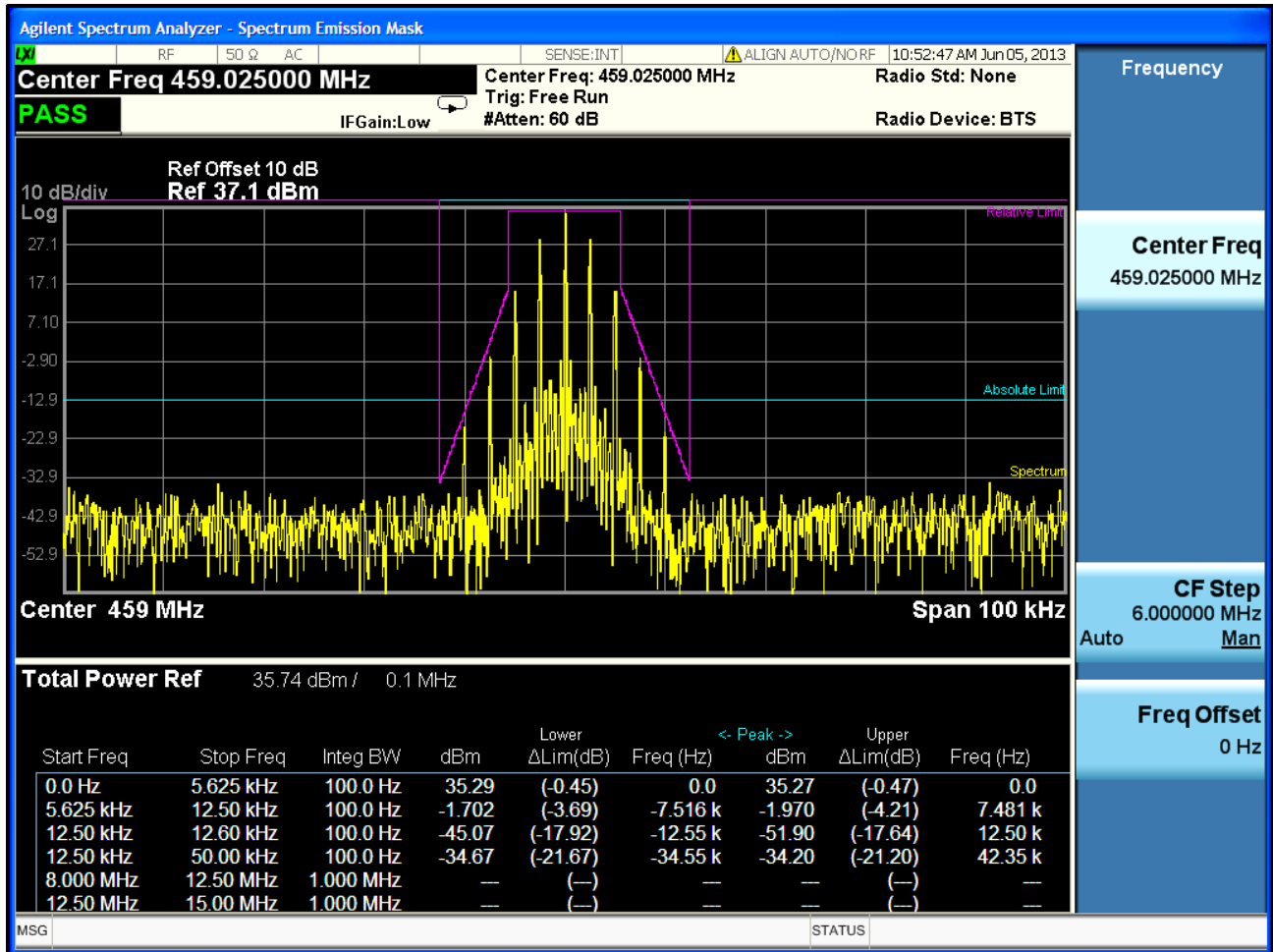

Plot 7-12: Occupied Bandwidth – 459.9750 MHz; Narrowband Analog; Mask D

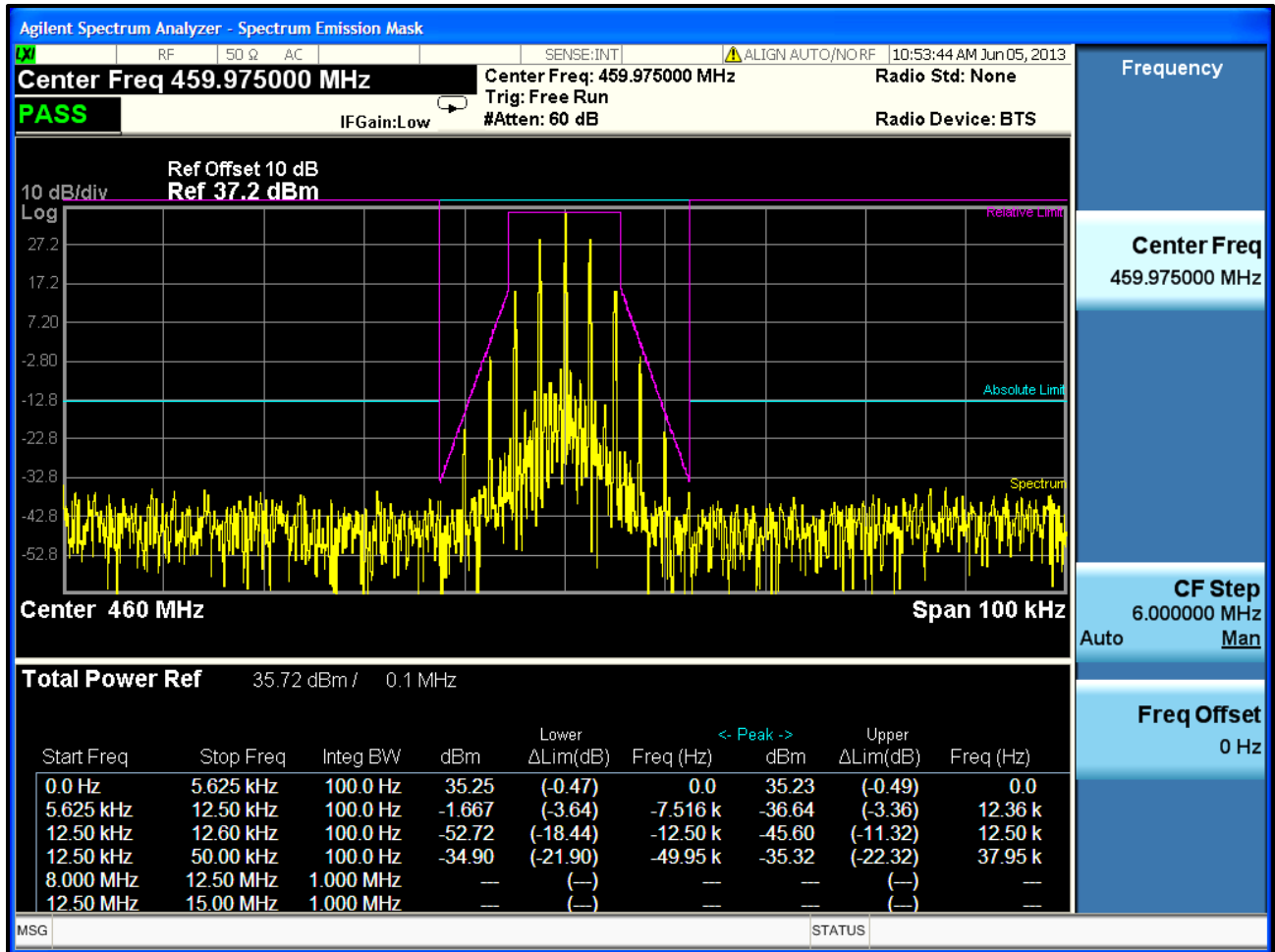

Plot 7-13: Occupied Bandwidth – 469.9875 MHz; Narrowband Analog; Mask D

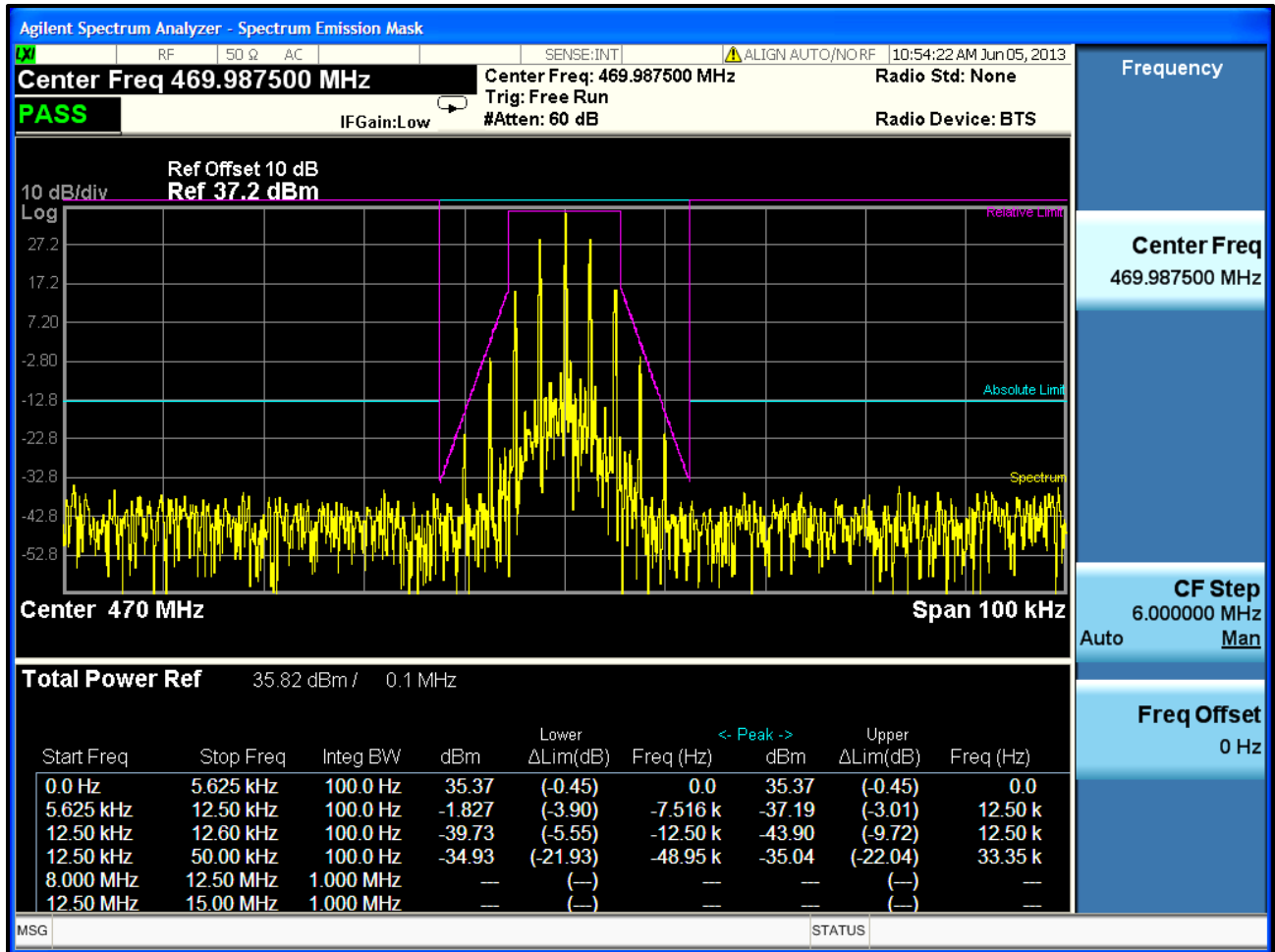

Plot 7-14: Occupied Bandwidth – 378.0125 MHz; Narrowband EDACS 9600 XNB; Mask D

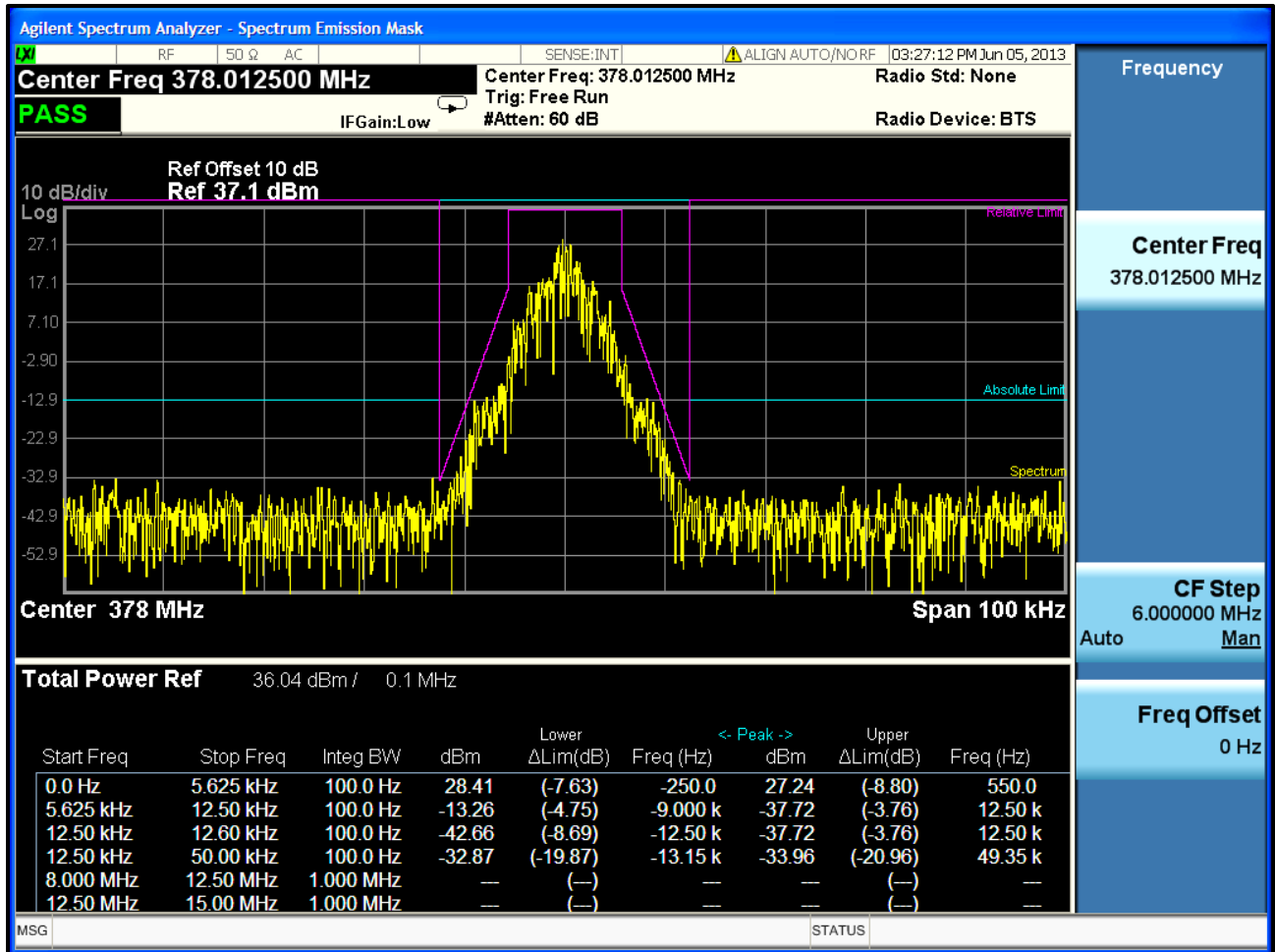

Plot 7-15: Occupied Bandwidth – 406.1125 MHz; Narrowband EDACS 9600 XNB; Mask D

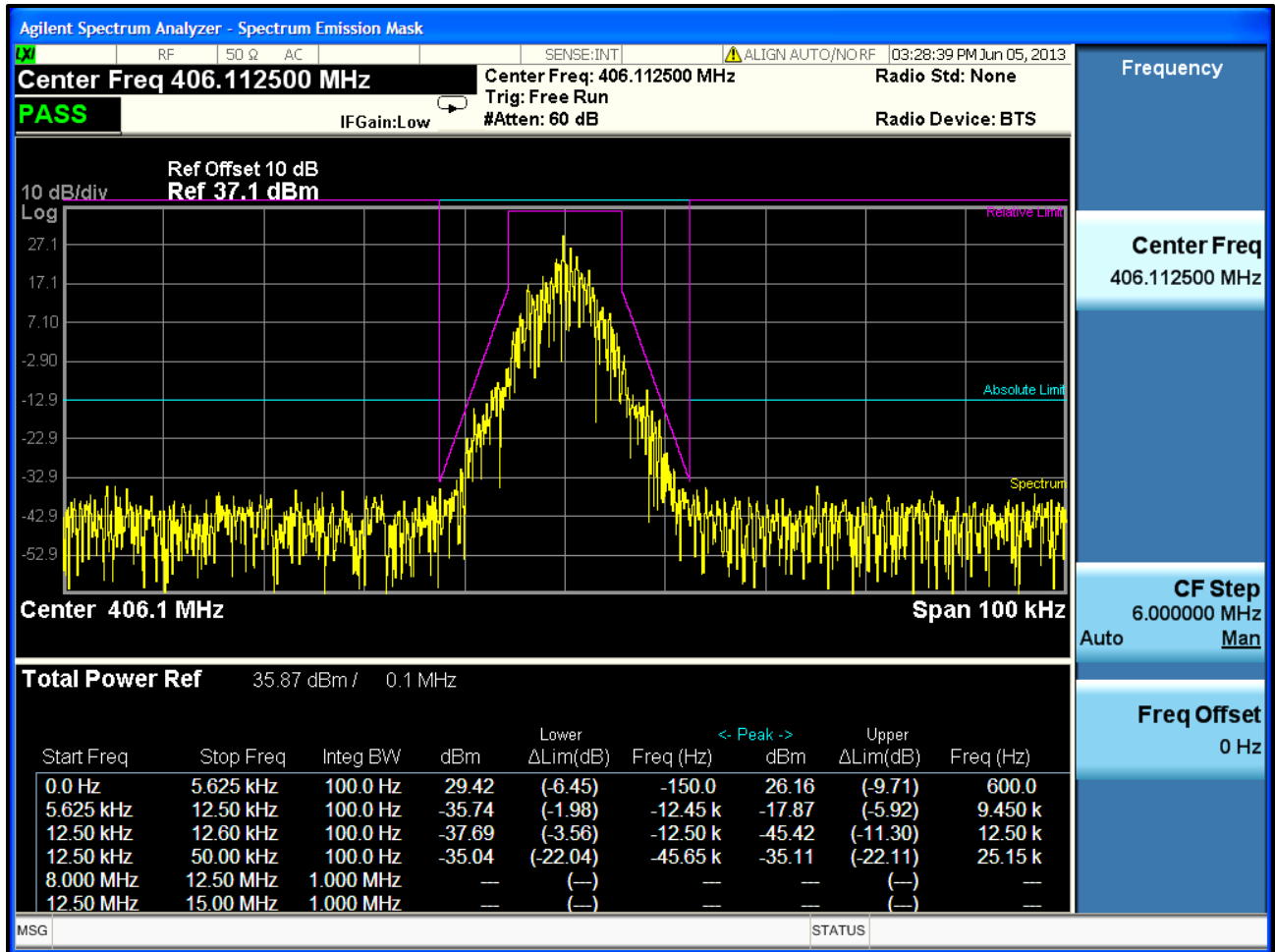

Plot 7-16: Occupied Bandwidth – 418.0000 MHz; Narrowband EDACS 9600 XNB; Mask D

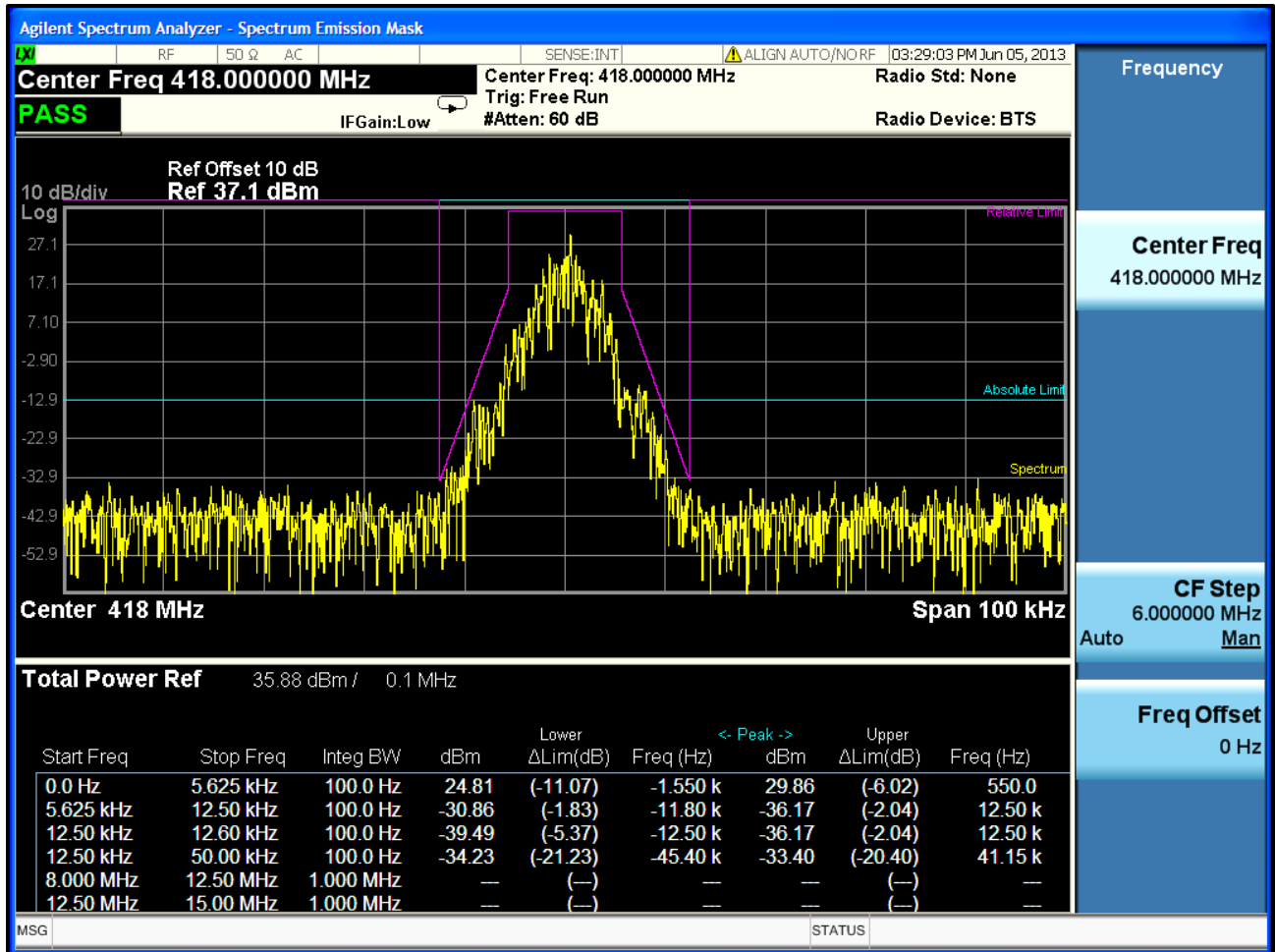

Plot 7-17: Occupied Bandwidth – 429.9875 MHz; Narrowband EDACS 9600 XNB; Mask D

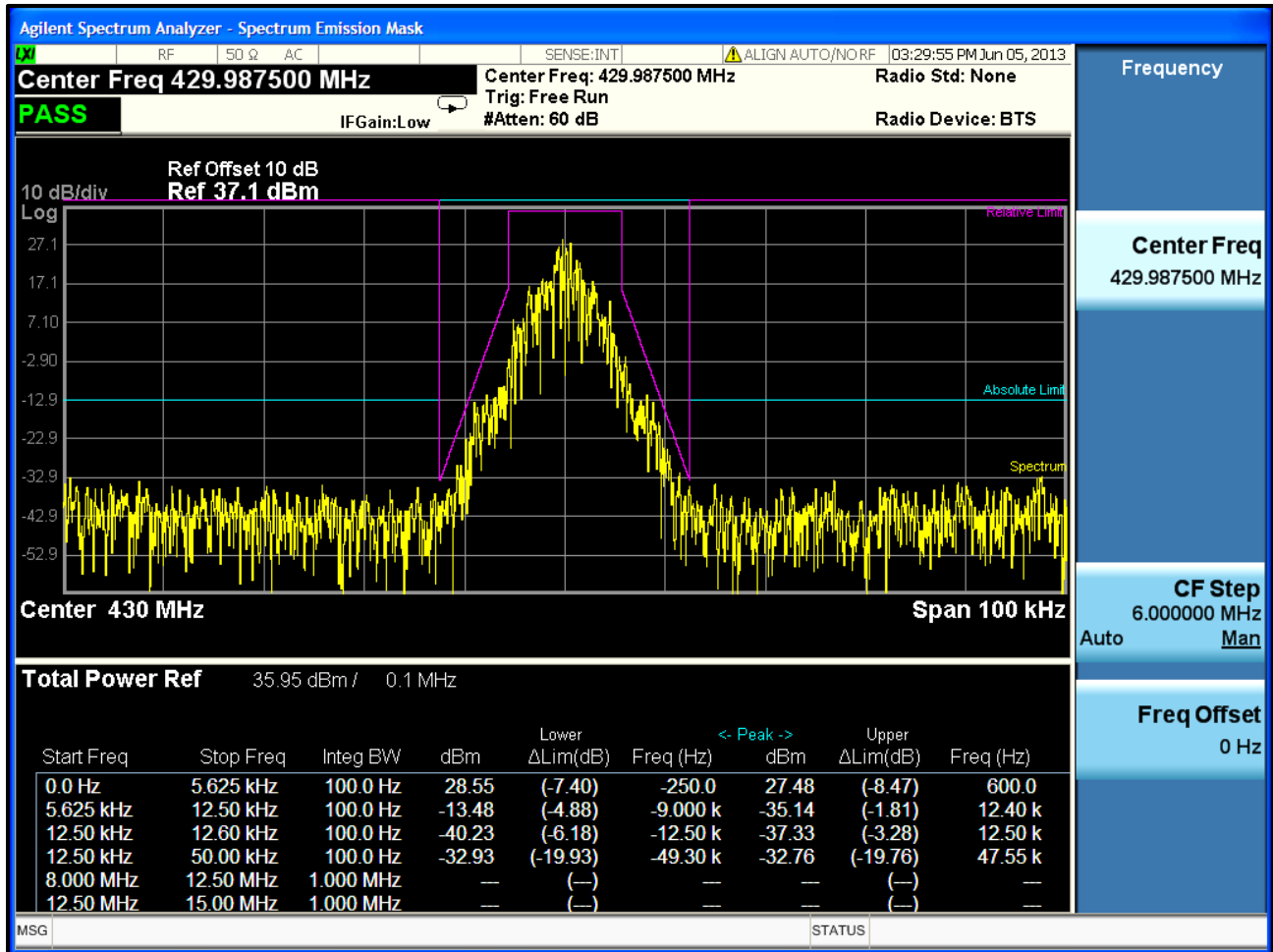

Plot 7-18: Occupied Bandwidth – 450.0125 MHz; Narrowband EDACS 9600 XNB; Mask D

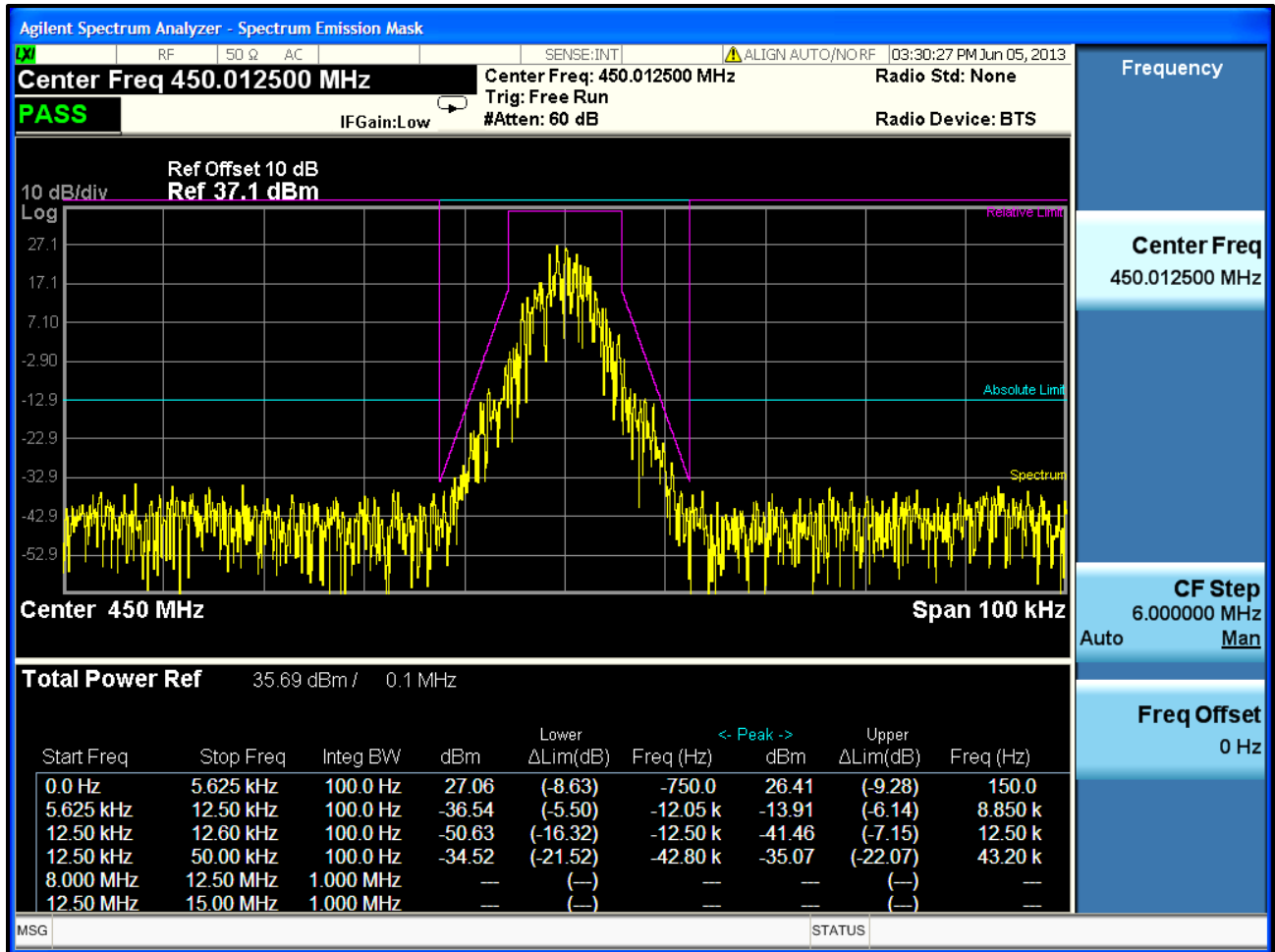

Plot 7-19: Occupied Bandwidth – 454.0125 MHz; Narrowband EDACS 9600 XNB; Mask D

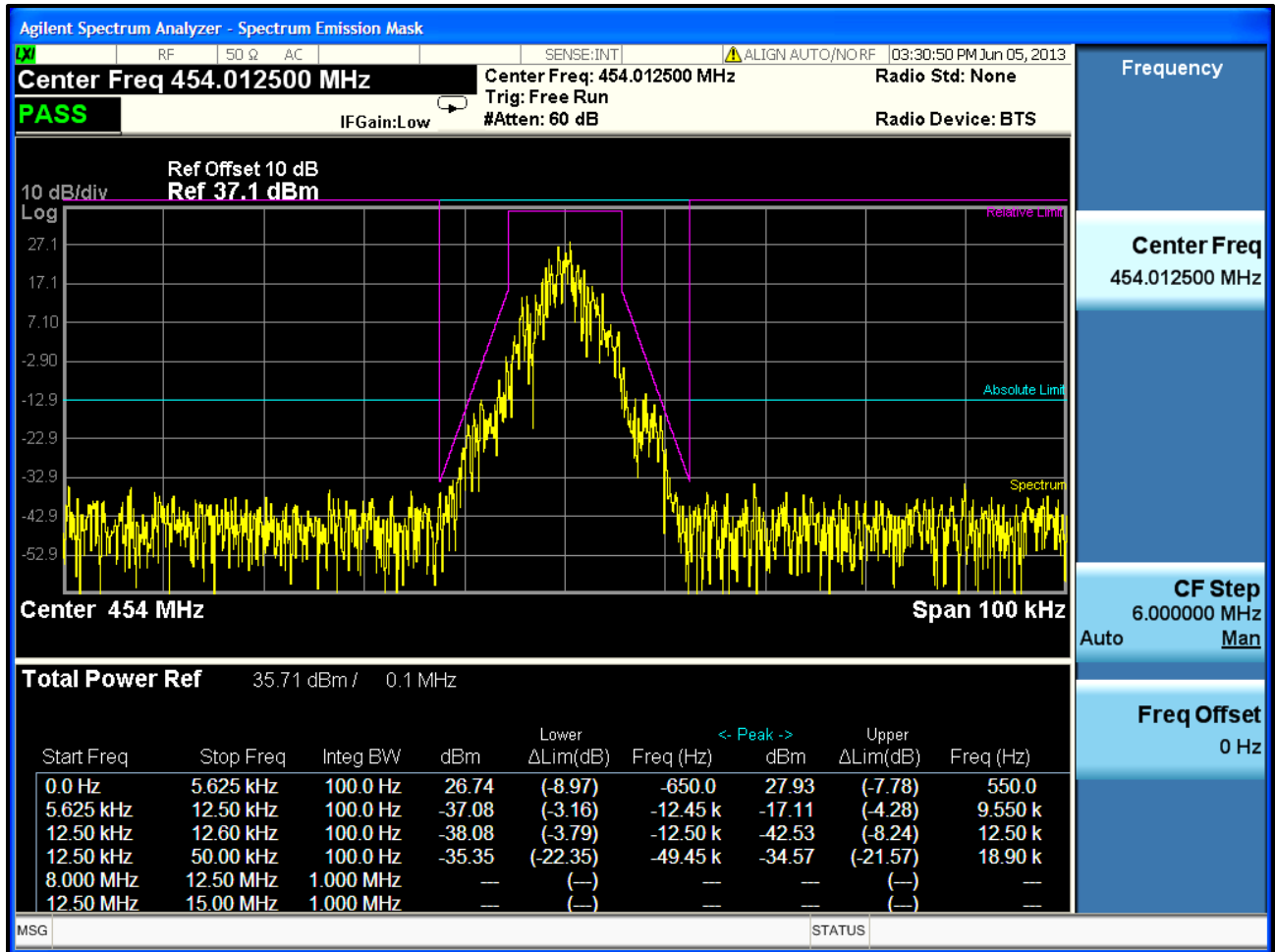

Plot 7-20: Occupied Bandwidth – 456.0125 MHz; Narrowband EDACS 9600 XNB; Mask D

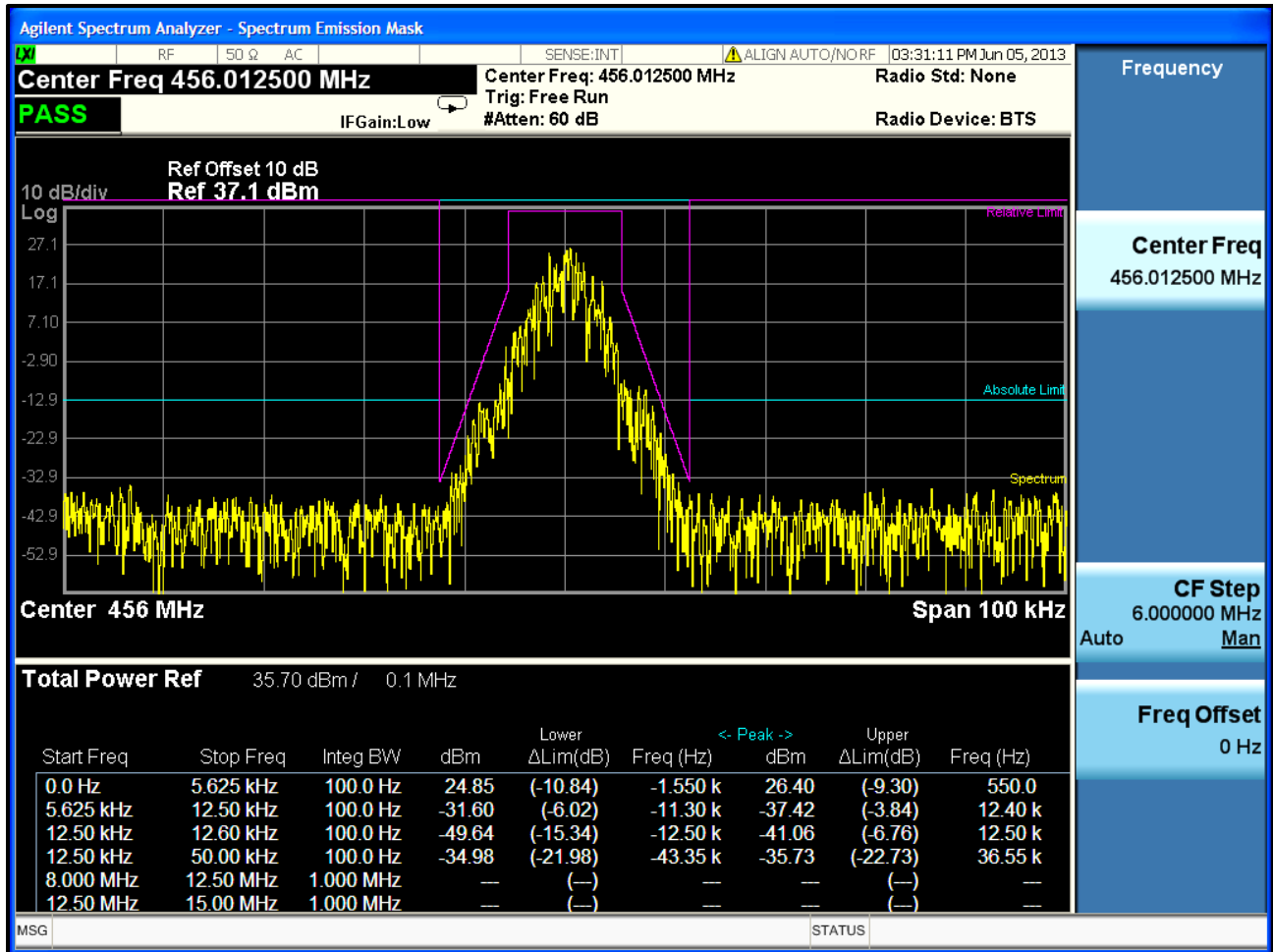

Plot 7-21: Occupied Bandwidth – 458.9875 MHz; Narrowband EDACS 9600 XNB; Mask D

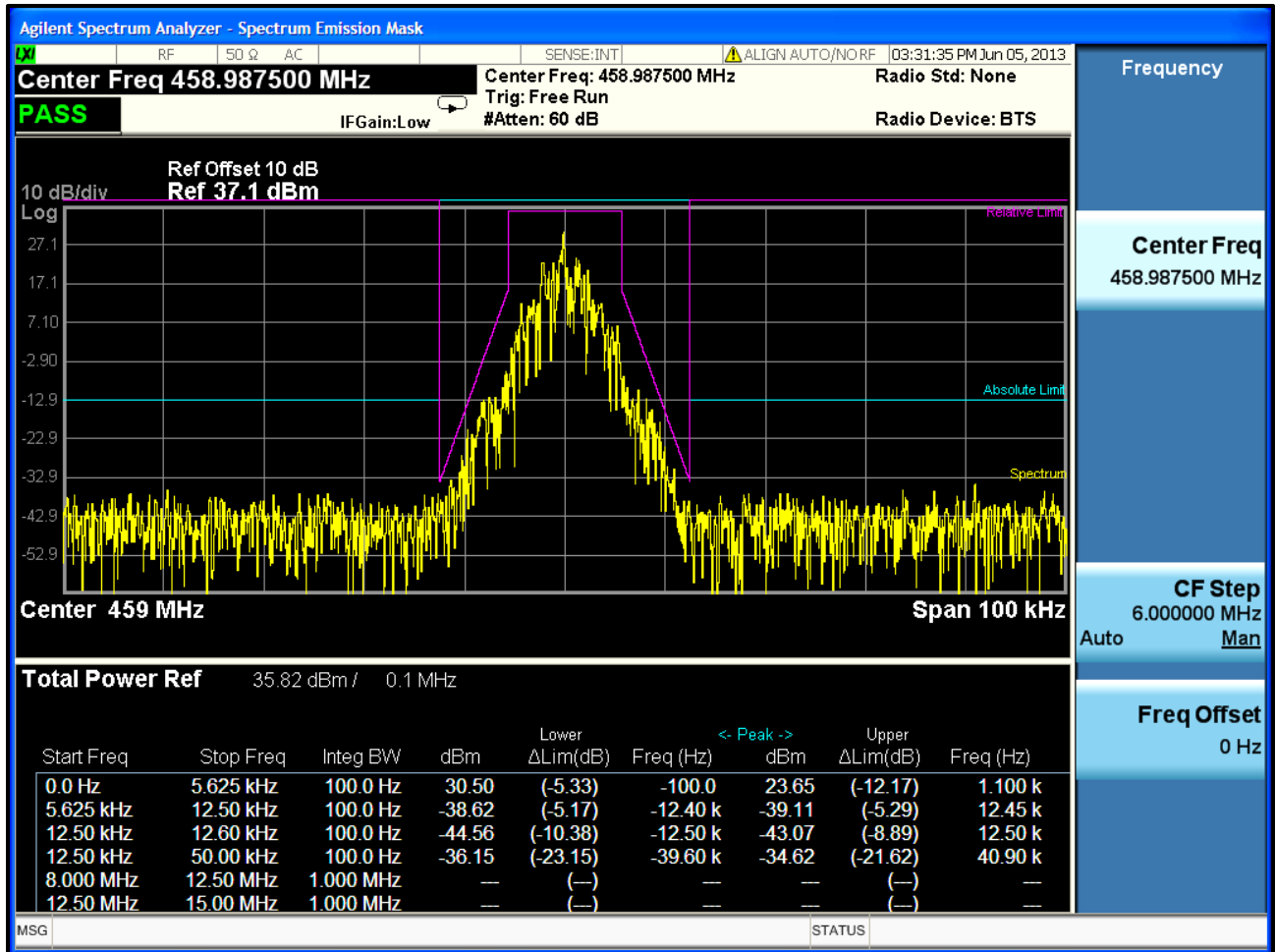

Plot 7-22: Occupied Bandwidth – 459.0250 MHz; Narrowband EDACS 9600 XNB; Mask D

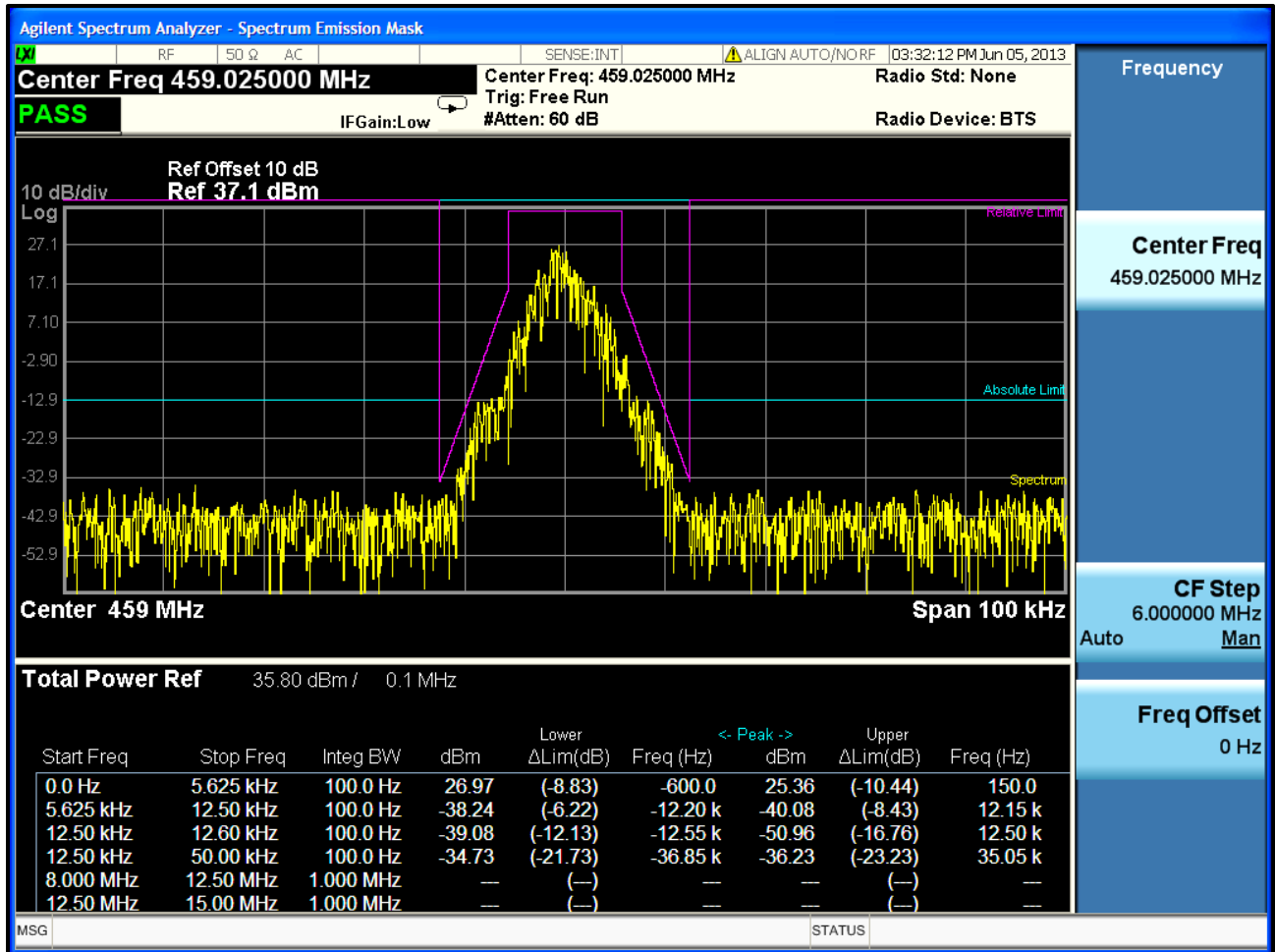

Plot 7-23: Occupied Bandwidth – 459.9750 MHz; Narrowband EDACS 9600 XNB; Mask D

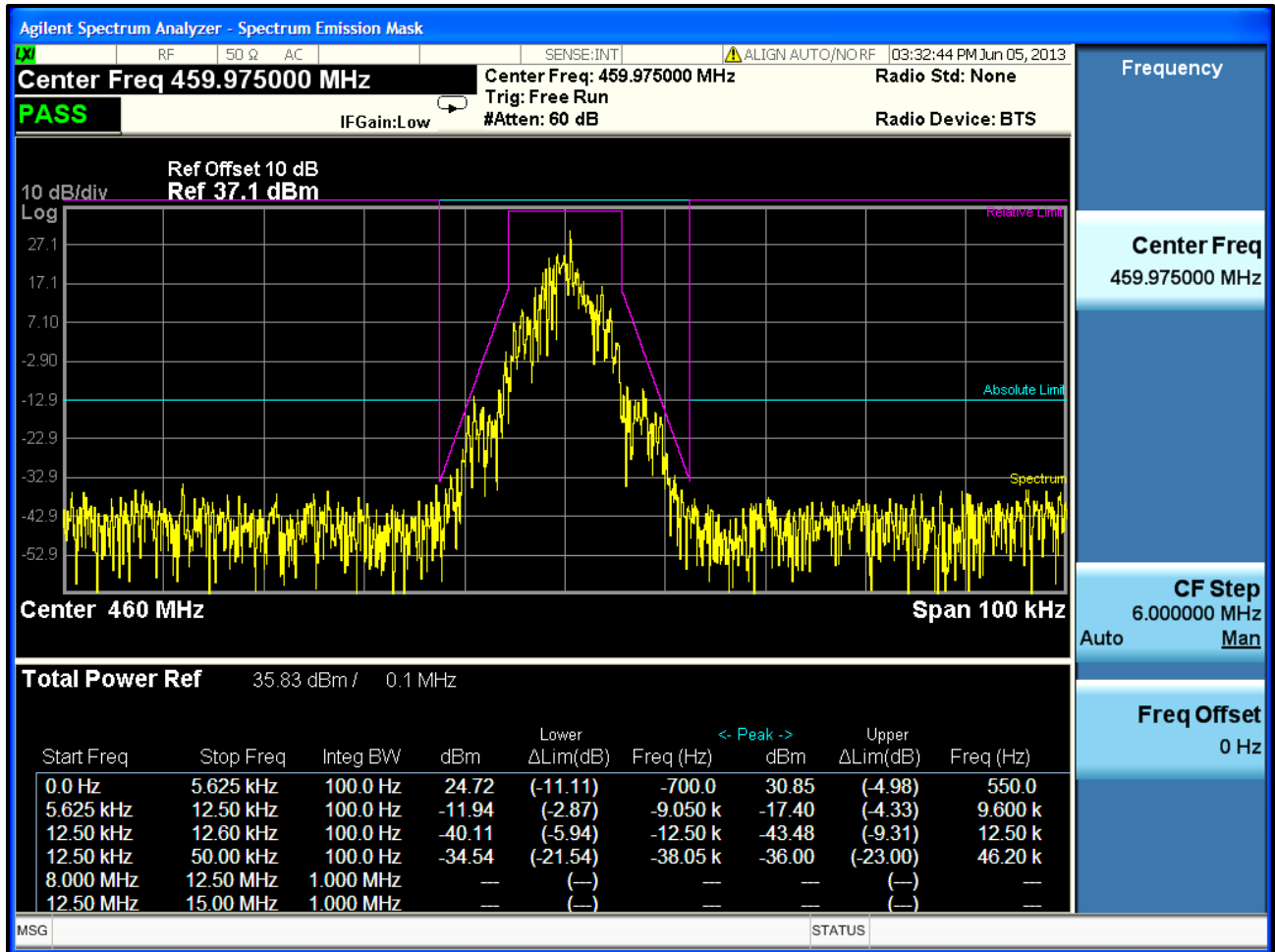

Plot 7-24: Occupied Bandwidth – 469.9875 MHz; Narrowband EDACS 9600 XNB; Mask D

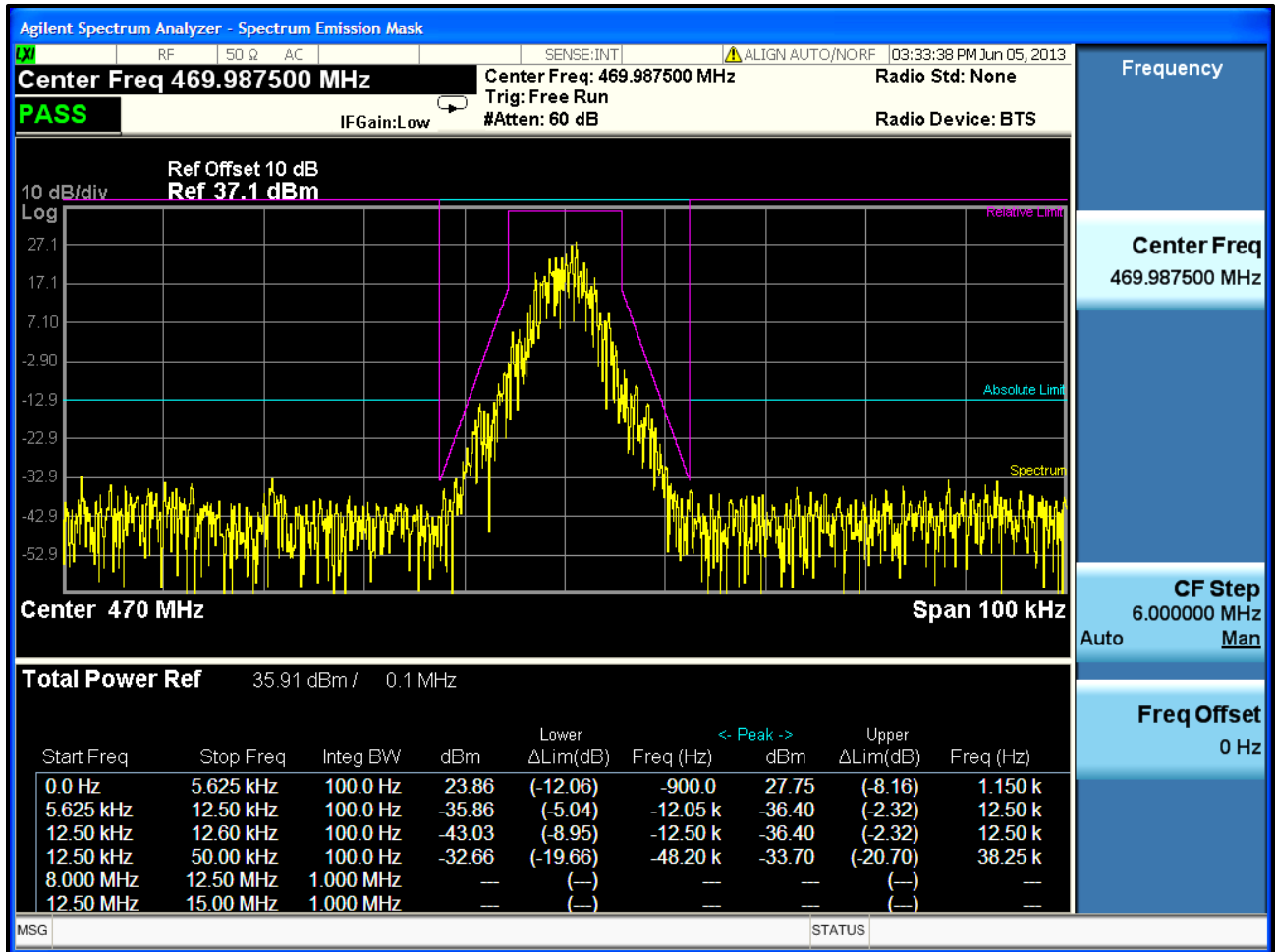

Plot 7-25: Occupied Bandwidth – 378.0125 MHz; Narrowband EDACS 4800 XNB; Mask D

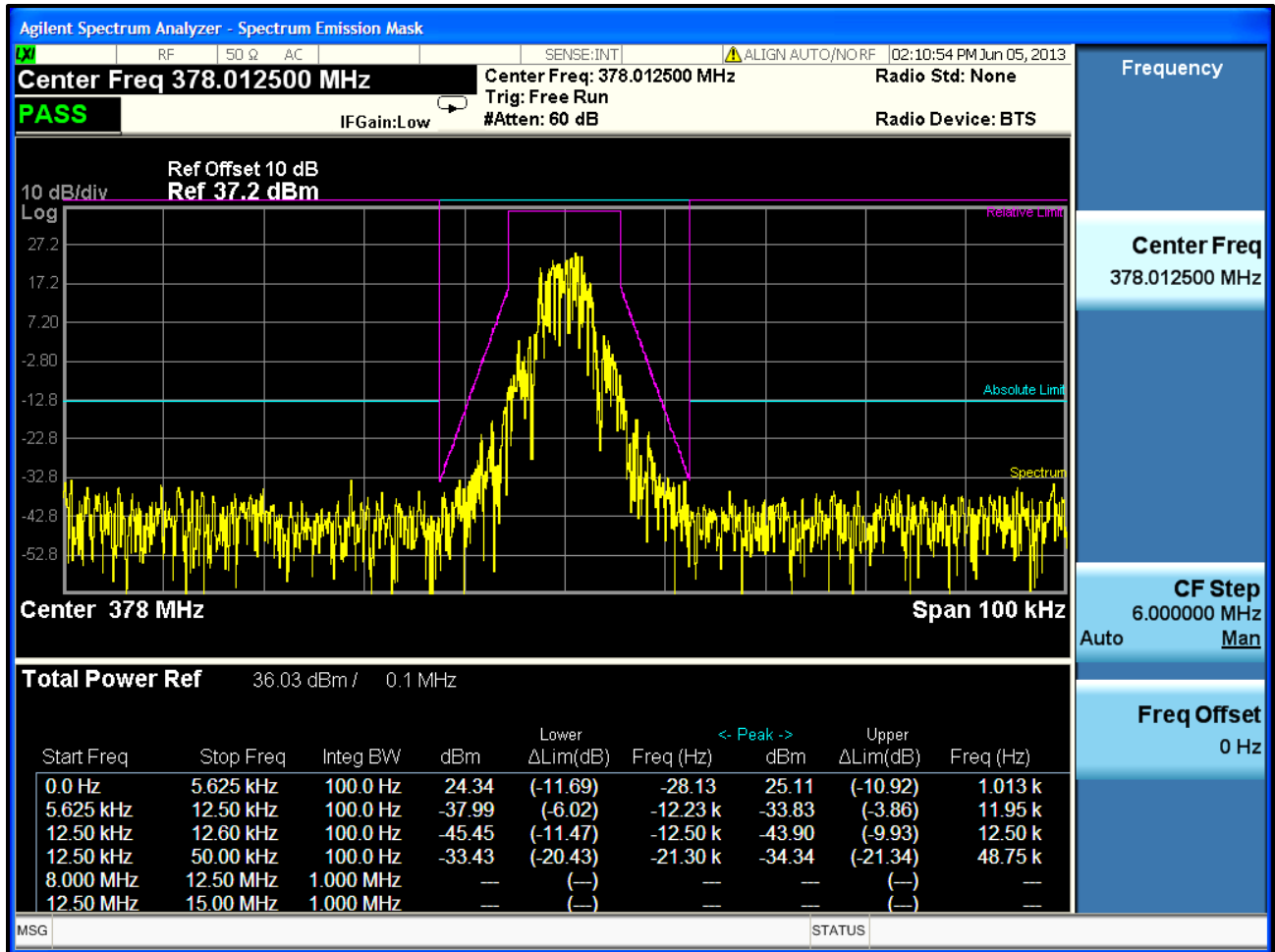

Plot 7-26: Occupied Bandwidth – 406.1125 MHz; Narrowband EDACS 4800 XNB; Mask D

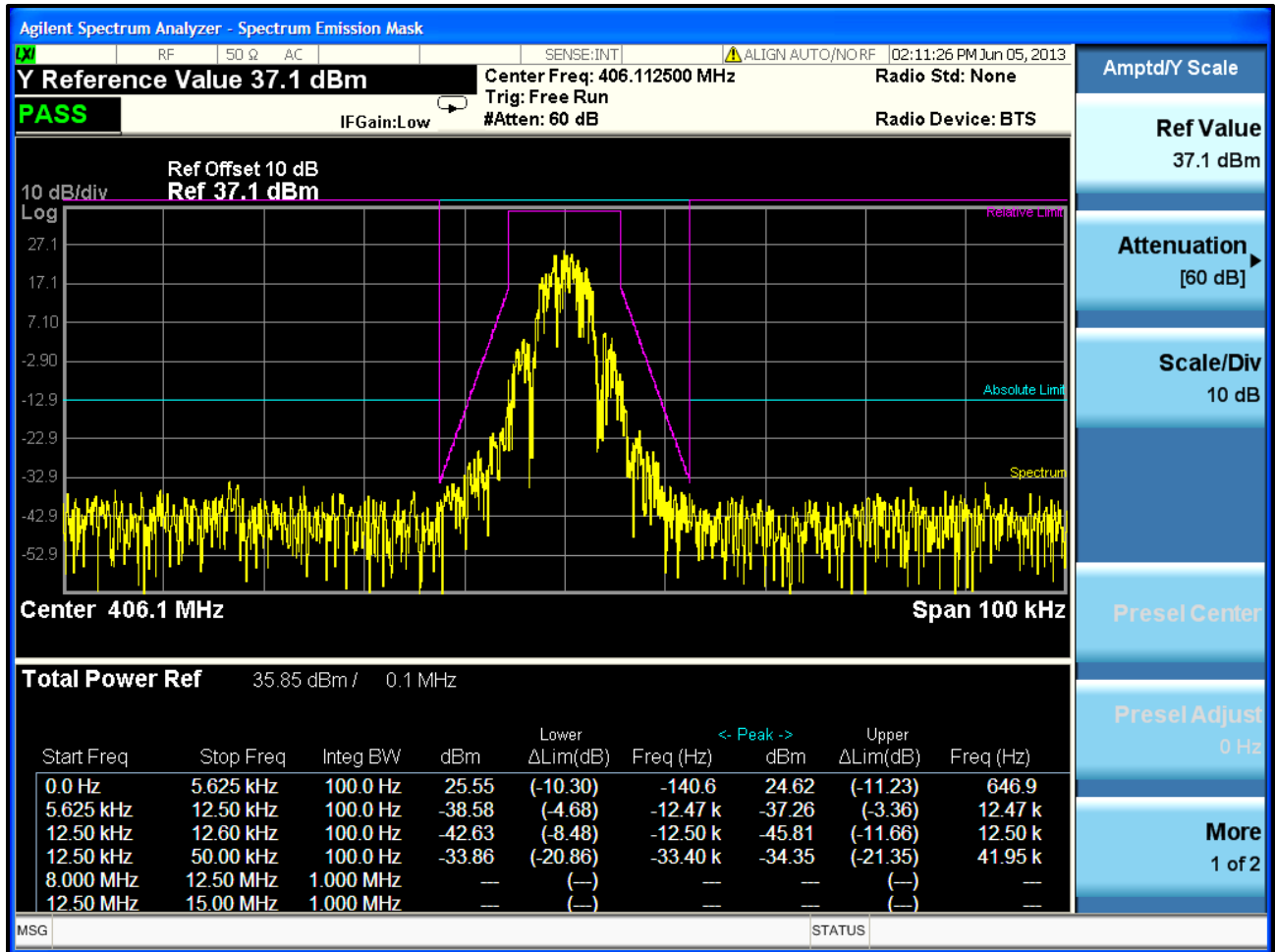

Plot 7-27: Occupied Bandwidth – 418.0000 MHz; Narrowband EDACS 4800 XNB; Mask D

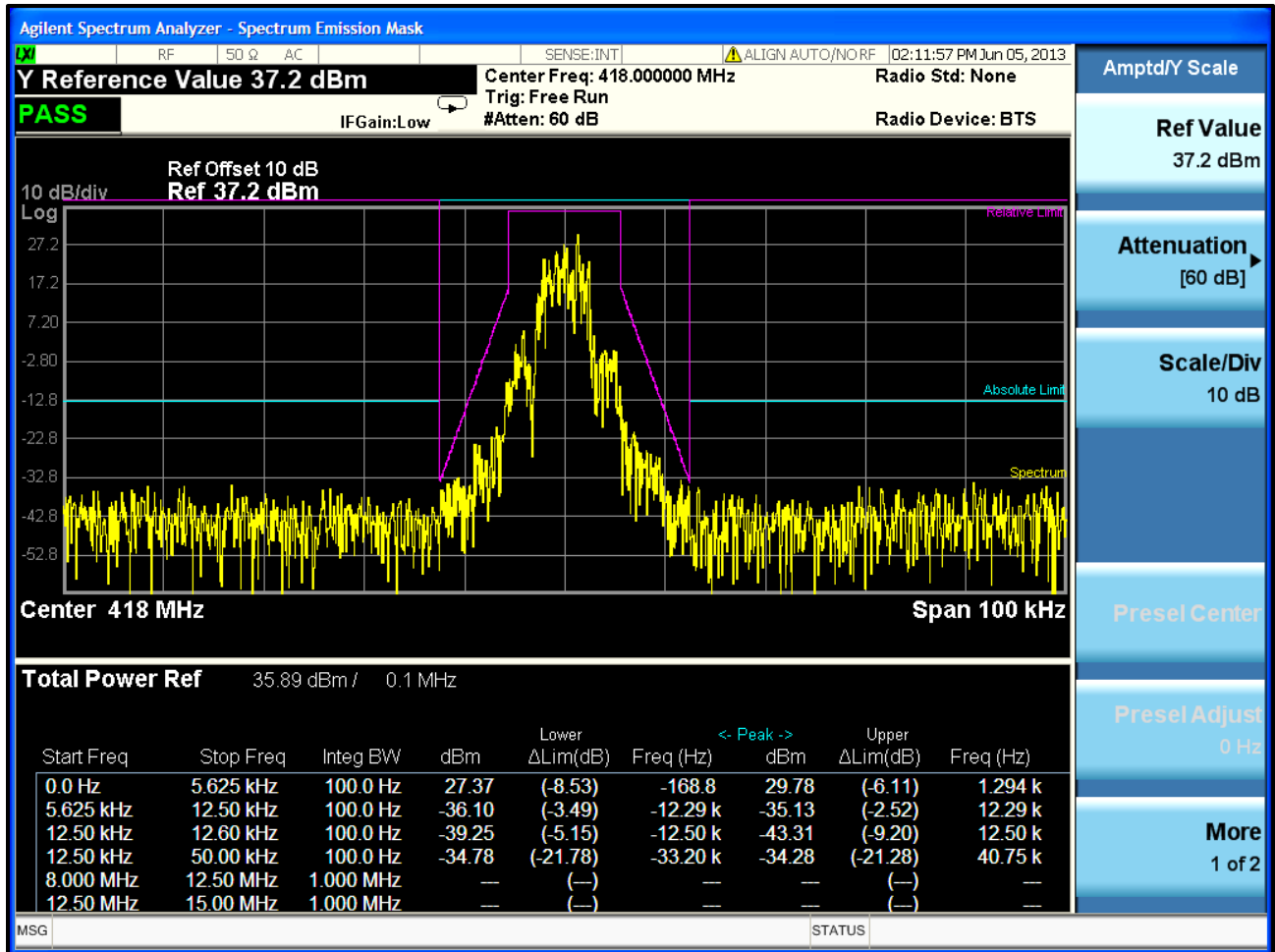

Plot 7-28: Occupied Bandwidth – 429.9875 MHz; Narrowband EDACS 4800 XNB; Mask D

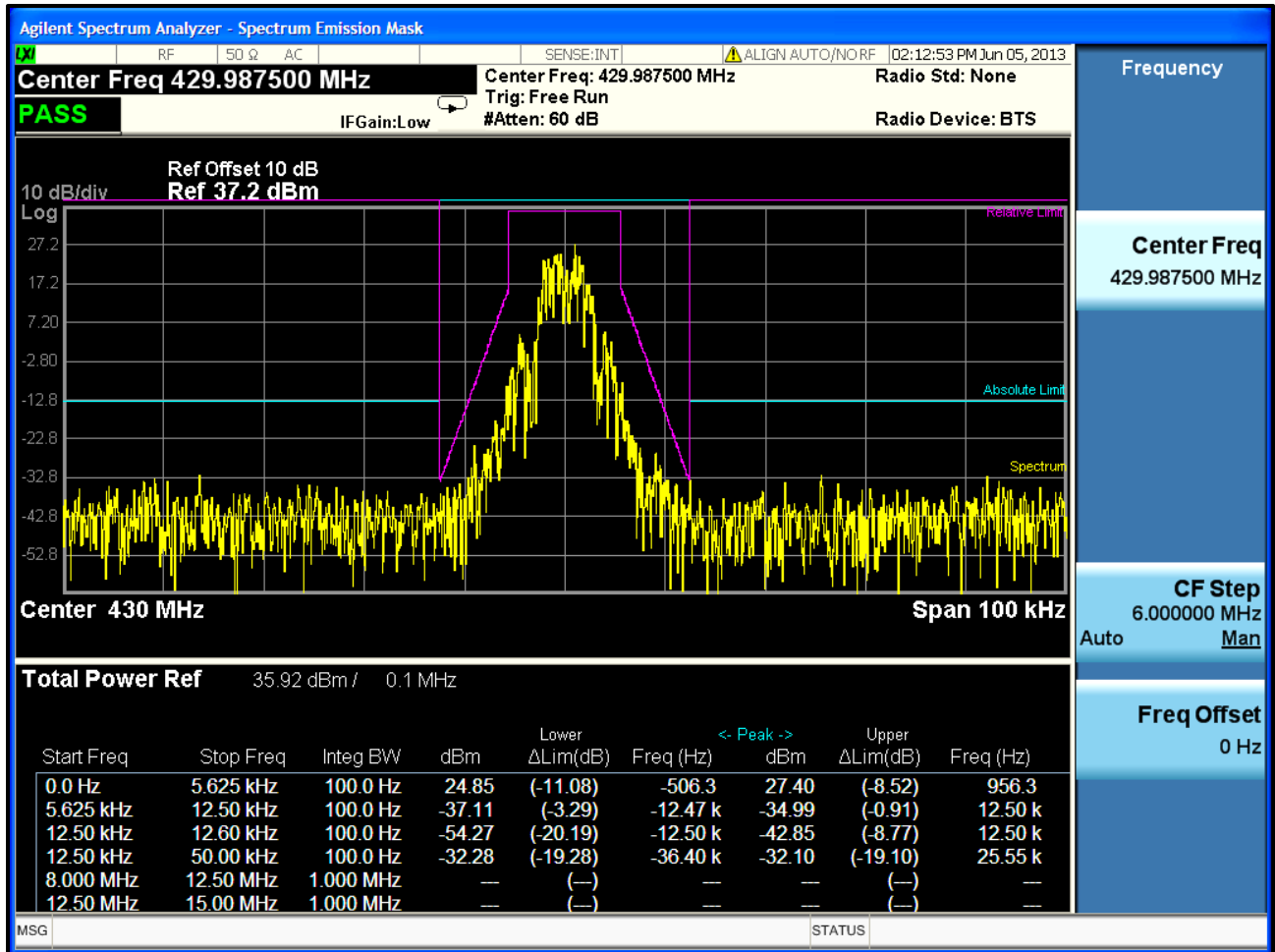

Plot 7-29: Occupied Bandwidth – 450.0125 MHz; Narrowband EDACS 4800 XNB; Mask D

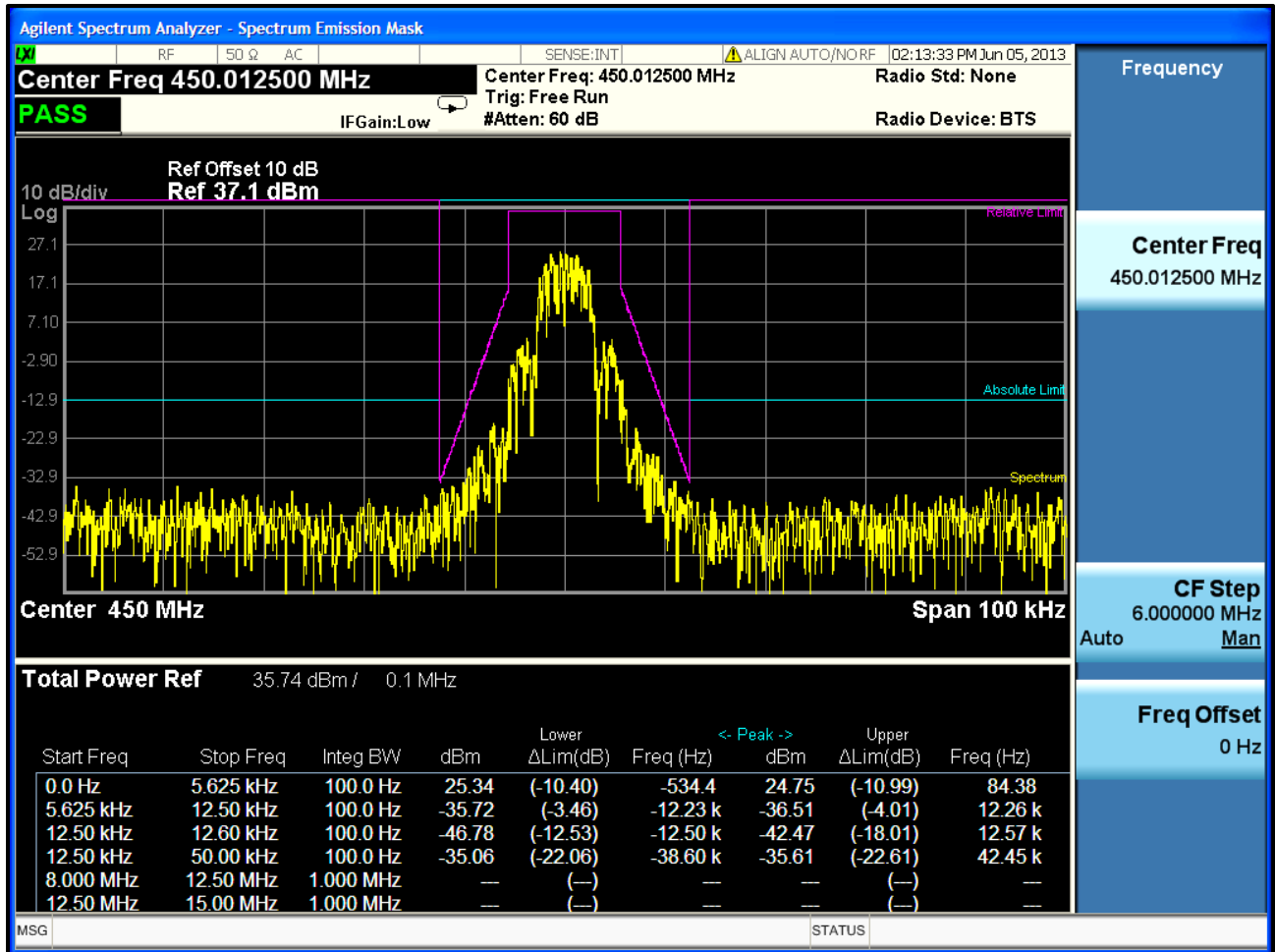

Plot 7-30: Occupied Bandwidth – 454.0125 MHz; Narrowband EDACS 4800 XNB; Mask D

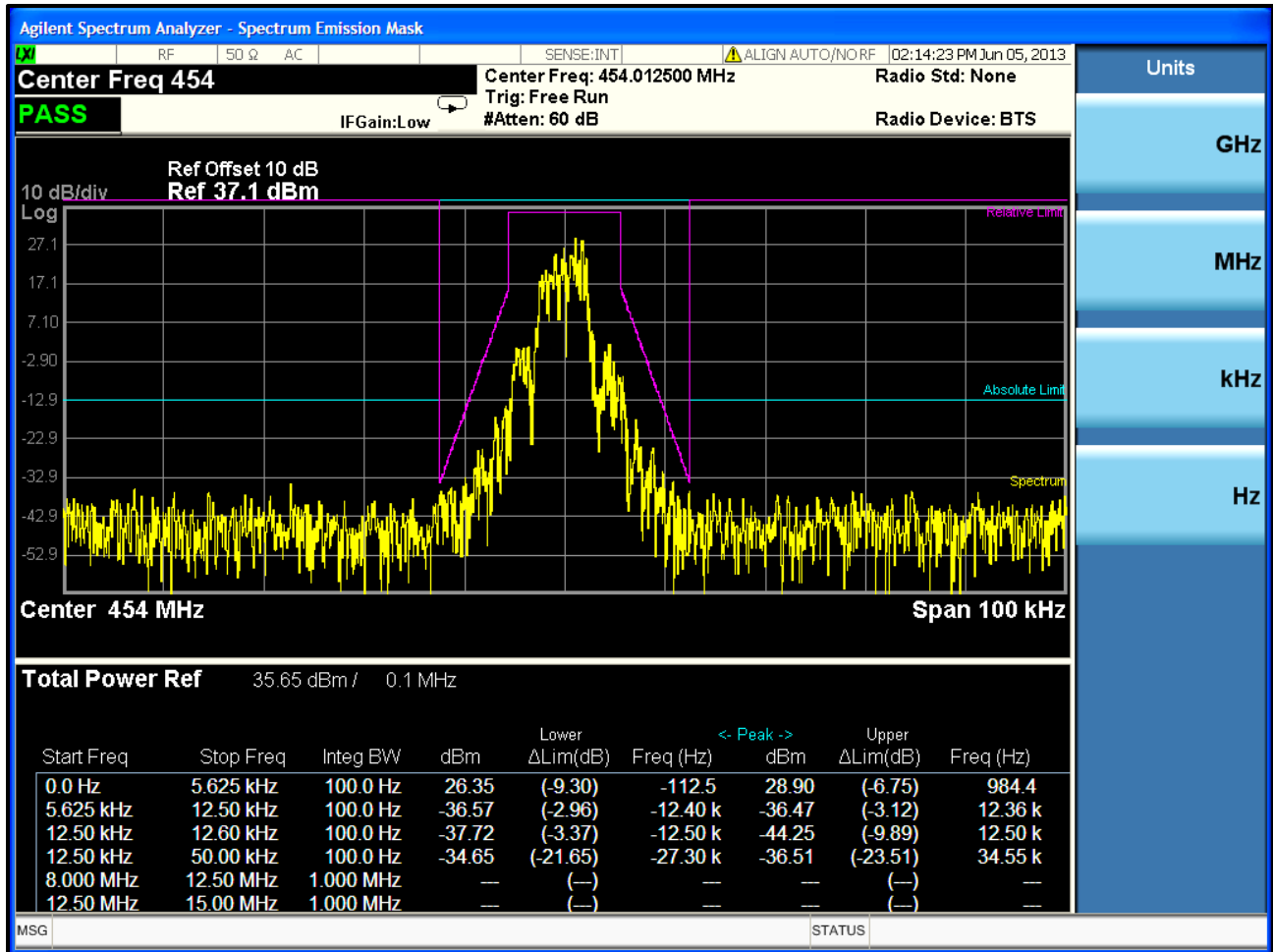

Plot 7-31: Occupied Bandwidth – 456.0125 MHz; Narrowband EDACS 4800 XNB; Mask D

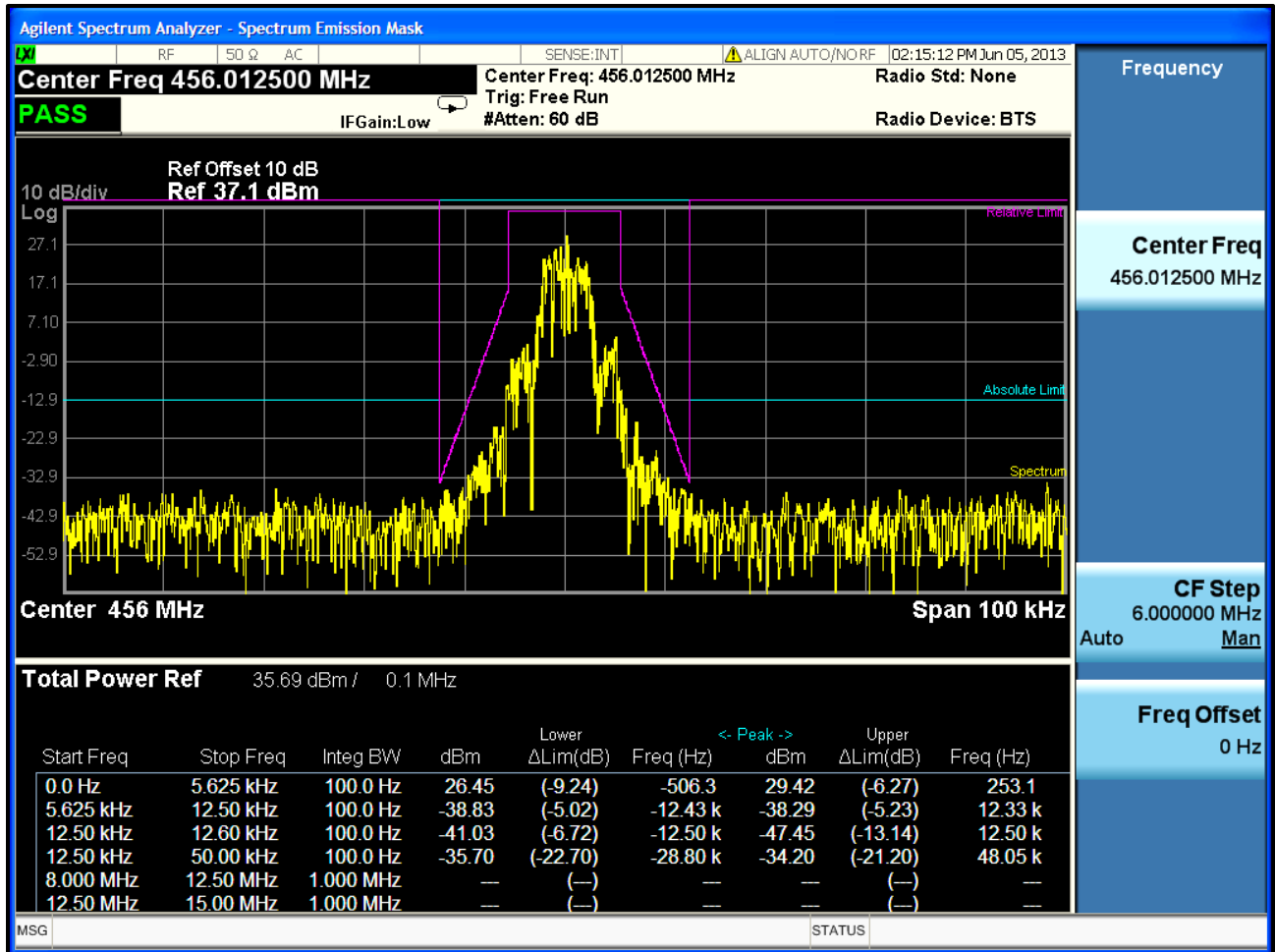

Plot 7-32: Occupied Bandwidth – 458.9875 MHz; Narrowband EDACS 4800 XNB; Mask D

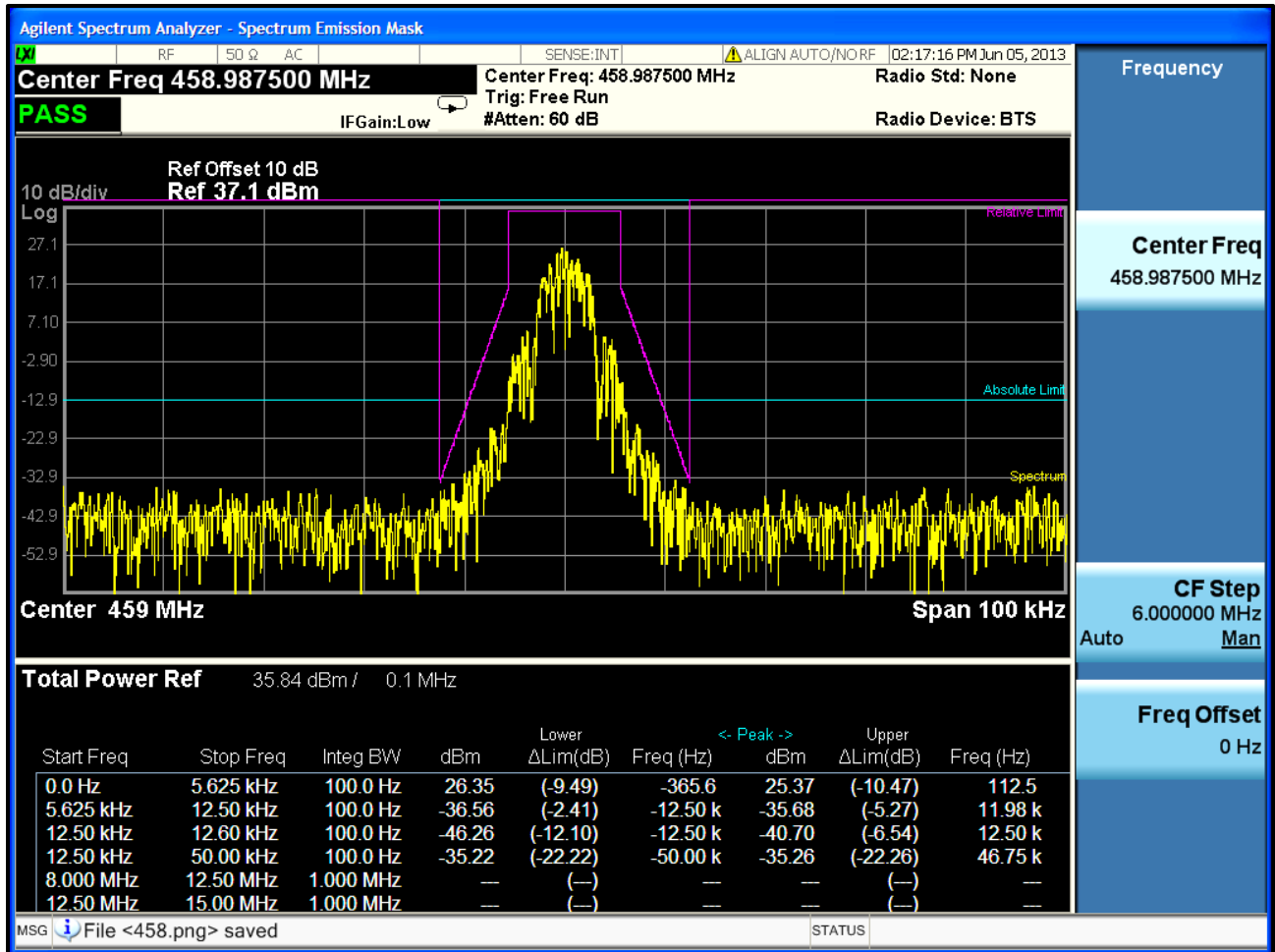

Plot 7-33: Occupied Bandwidth – 459.0250 MHz; Narrowband EDACS 4800 XNB; Mask D

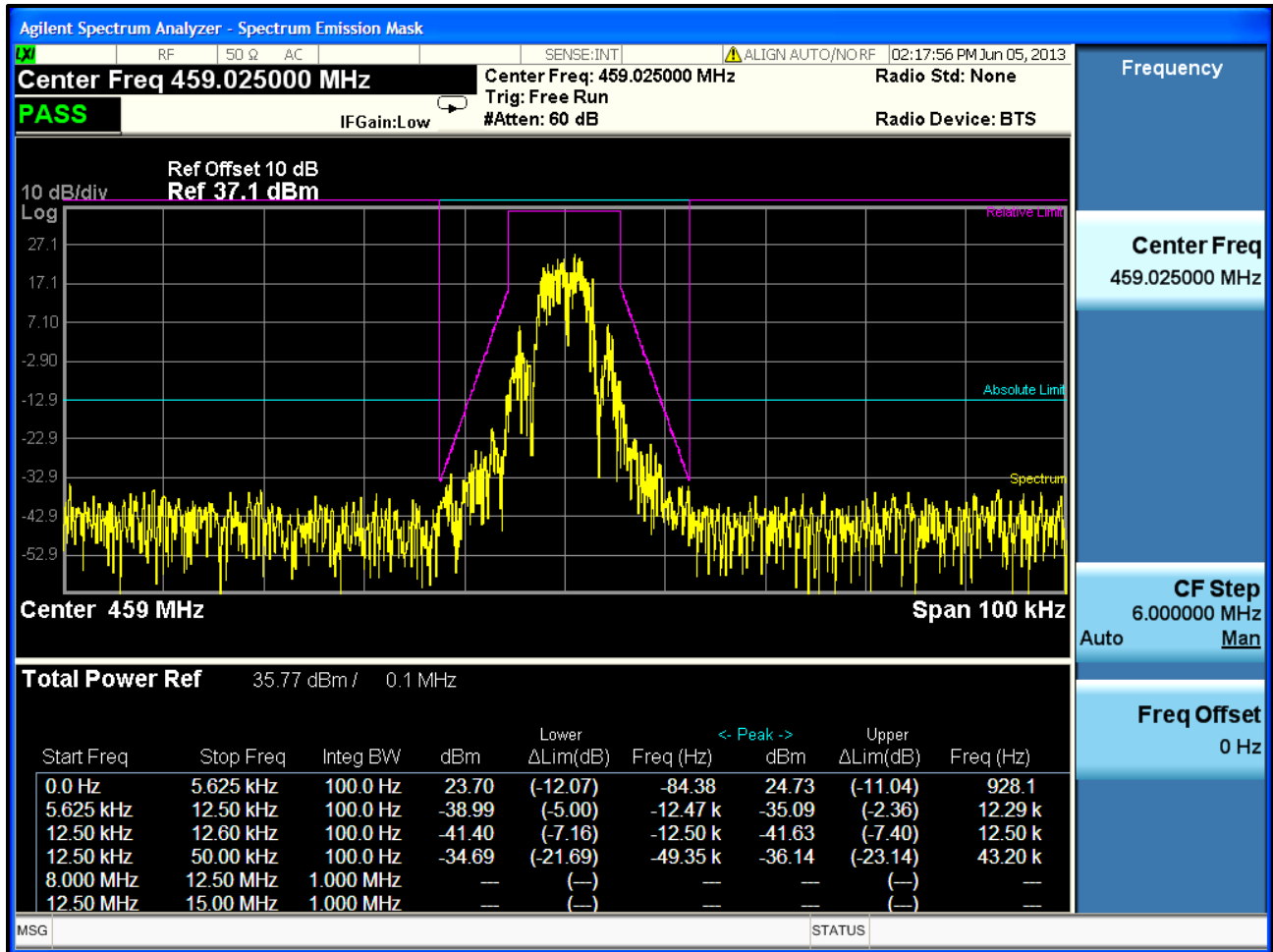

Plot 7-34: Occupied Bandwidth – 459.9750 MHz; Narrowband EDACS 4800 XNB; Mask D

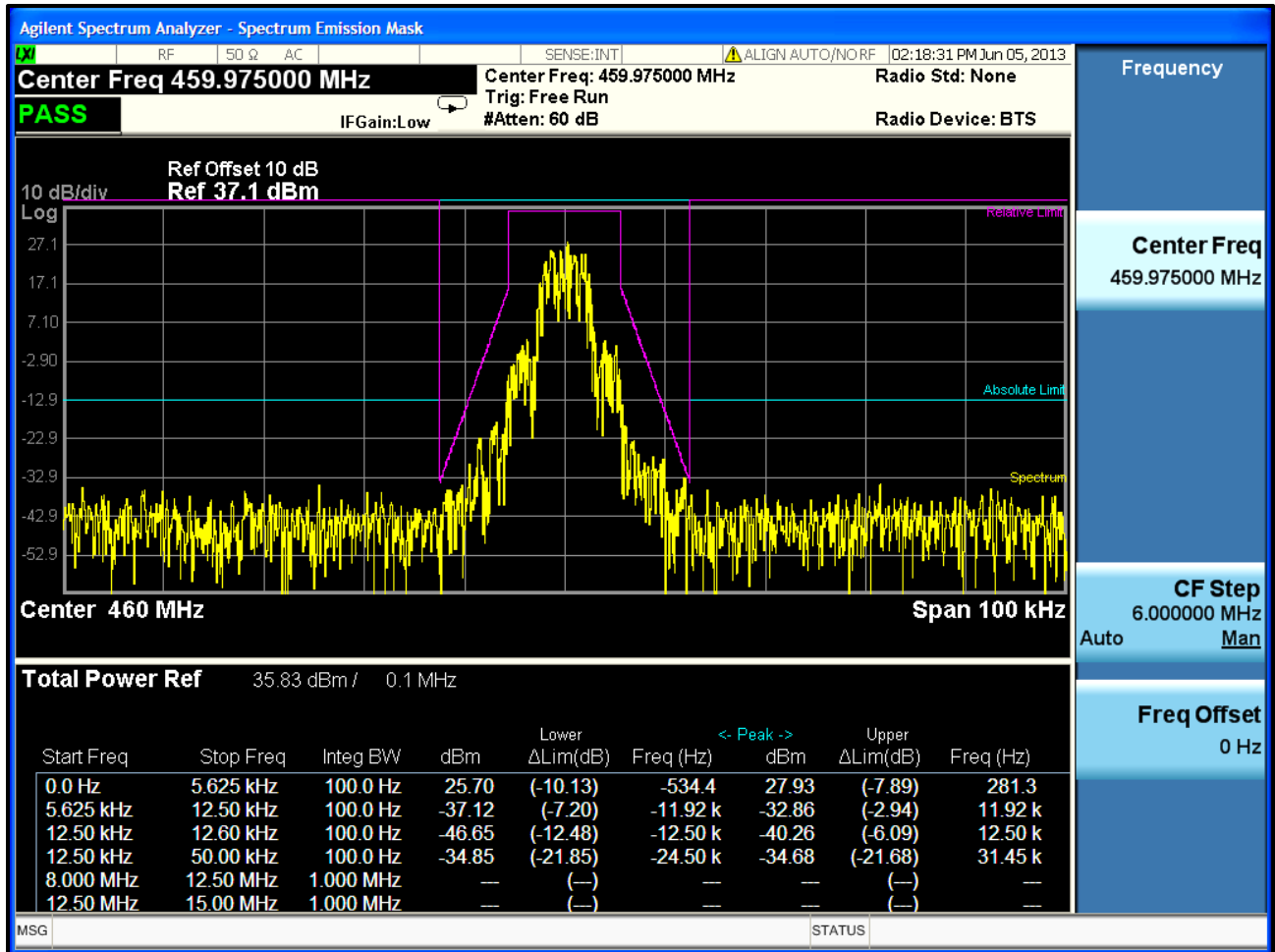

Plot 7-35: Occupied Bandwidth – 469.9875 MHz; Narrowband EDACS 4800 XNB; Mask D

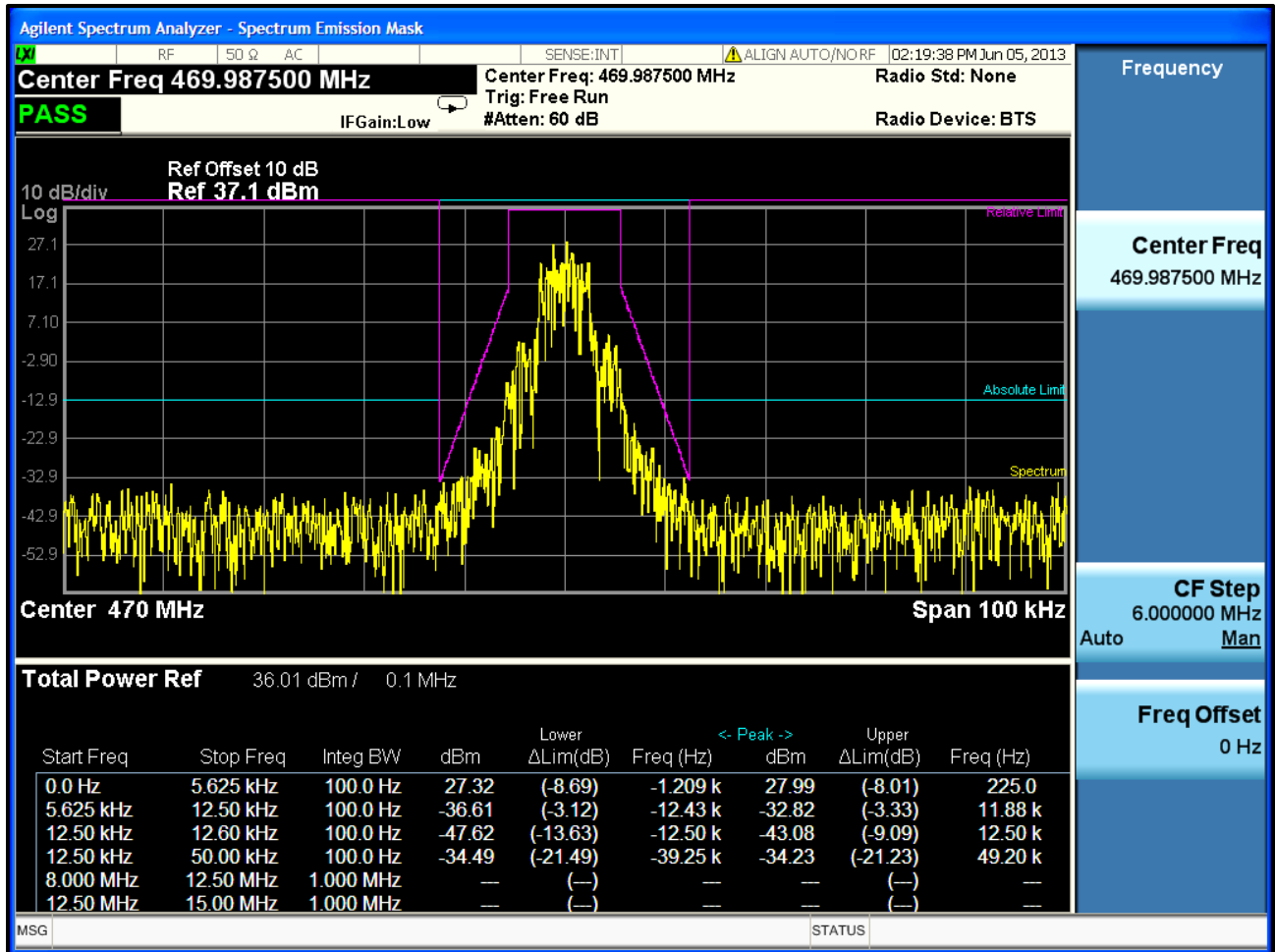

Plot 7-36: Occupied Bandwidth – 378.0125 MHz; Narrowband P25 Ph2; Mask D

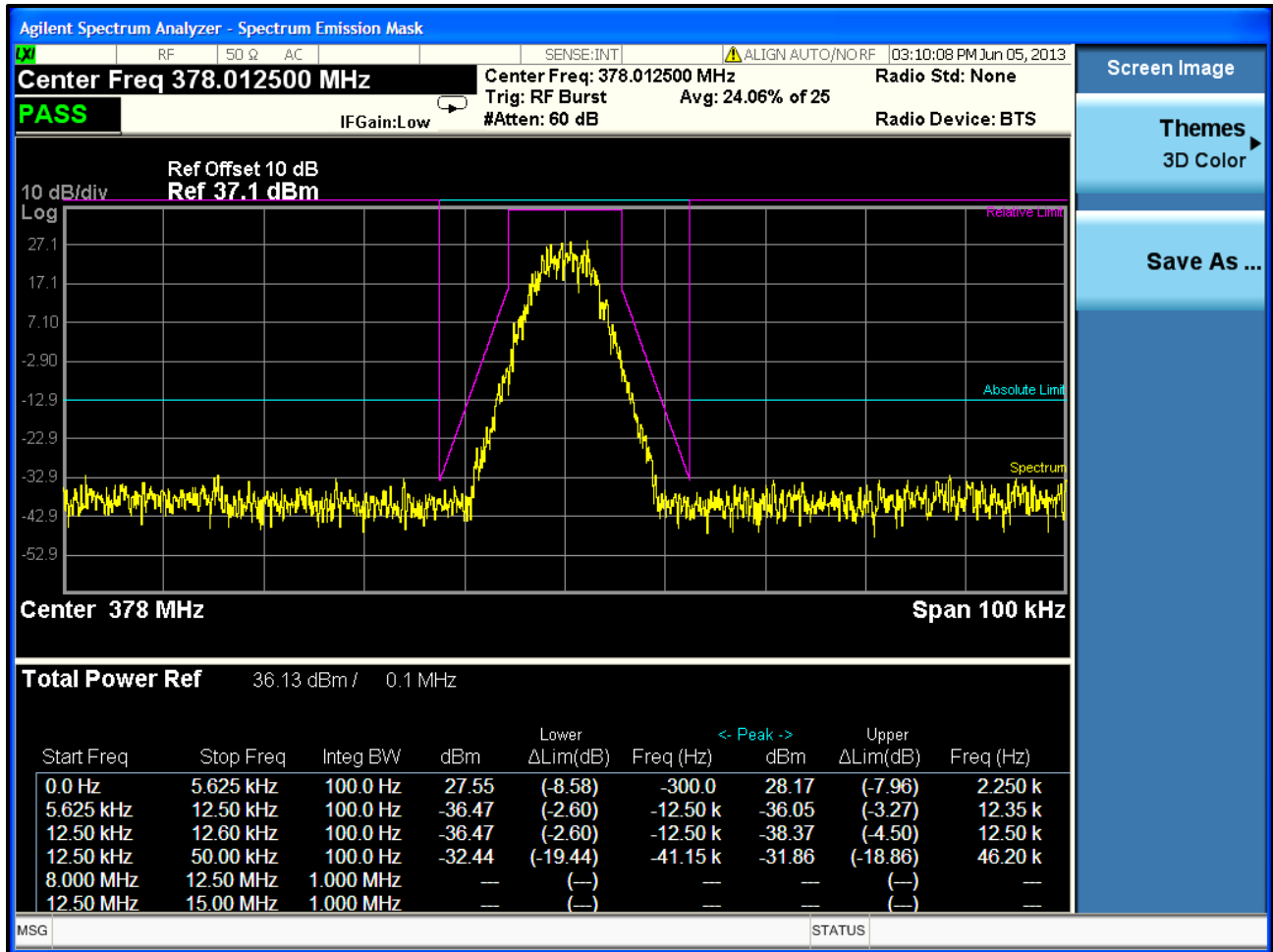

Plot 7-37: Occupied Bandwidth – 406.1125 MHz; Narrowband P25 Ph2; Mask D

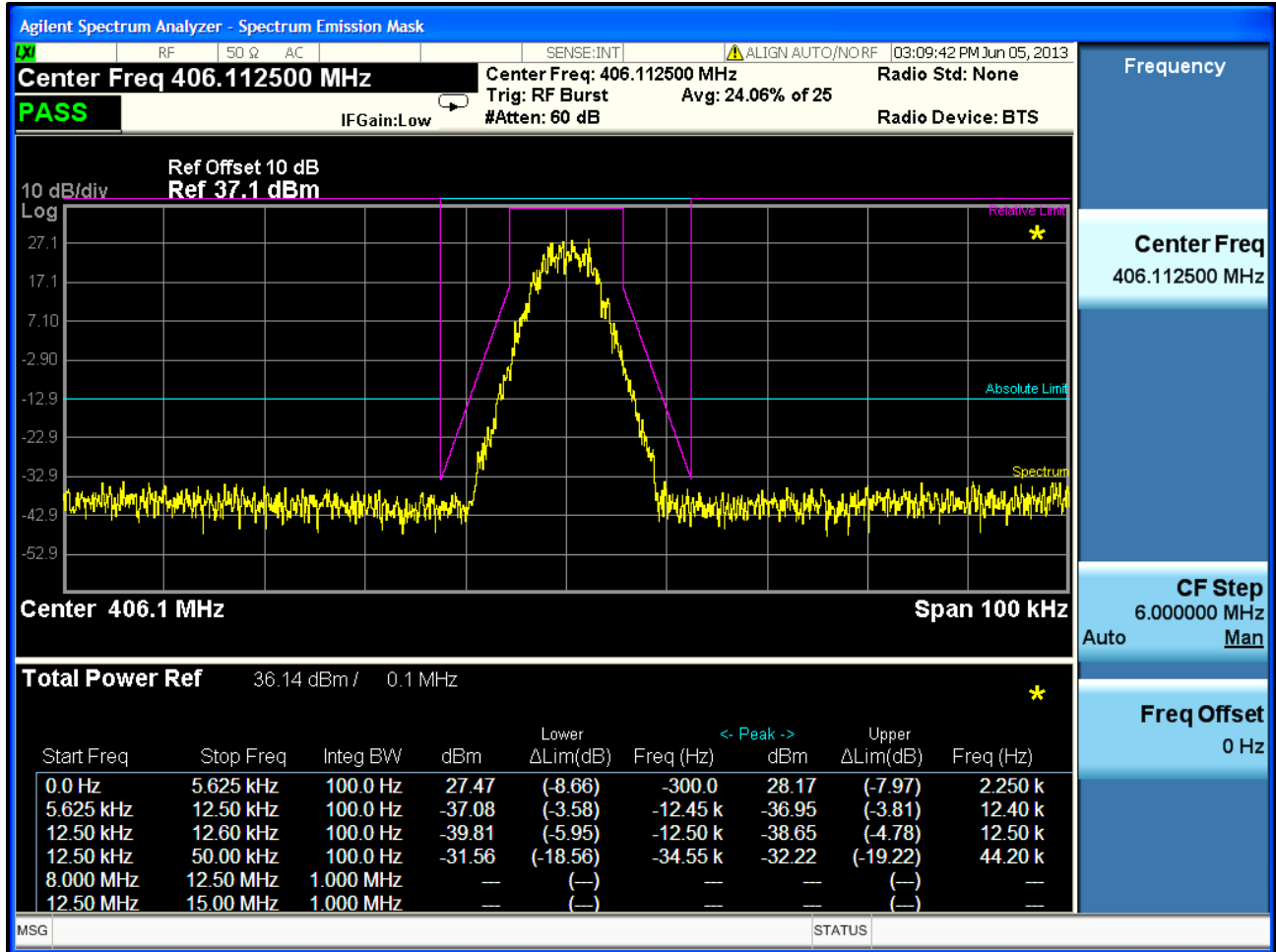

Plot 7-38: Occupied Bandwidth – 418.0000 MHz; Narrowband P25 Ph2; Mask D

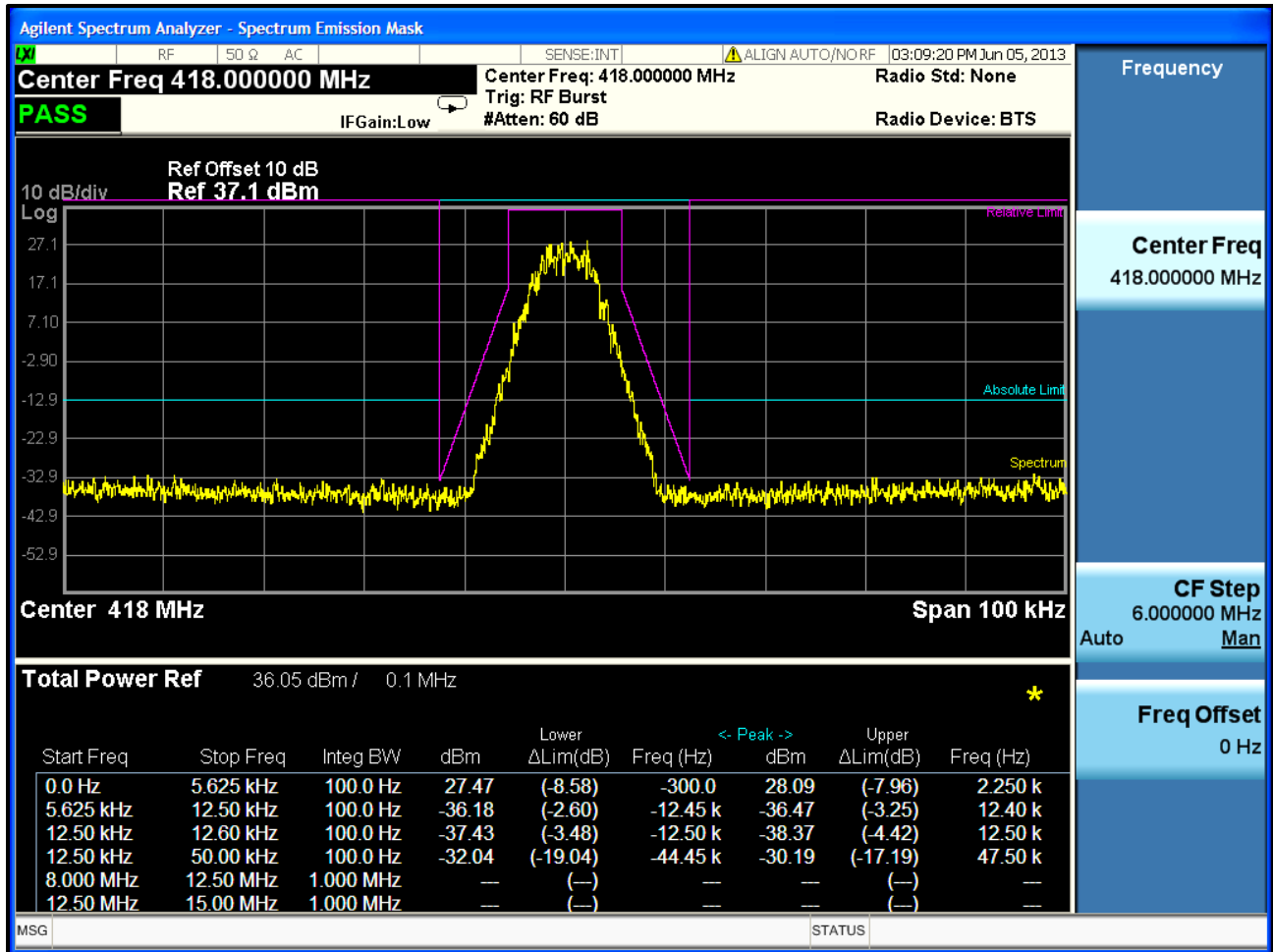

Plot 7-39: Occupied Bandwidth – 429.9875 MHz; Narrowband P25 Ph2; Mask D

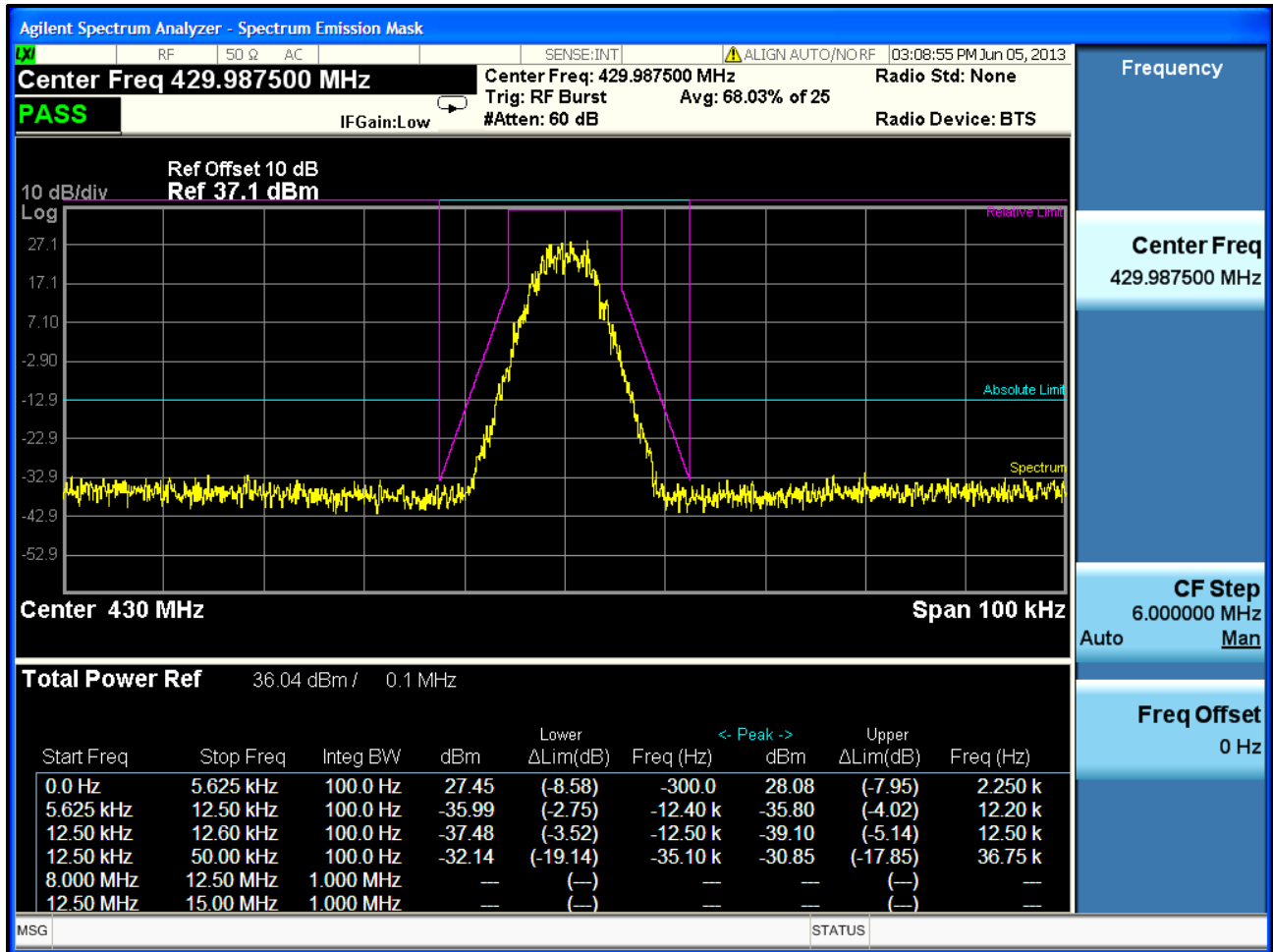

Plot 7-40: Occupied Bandwidth – 454.0125 MHz; Narrowband P25 Ph2; Mask D

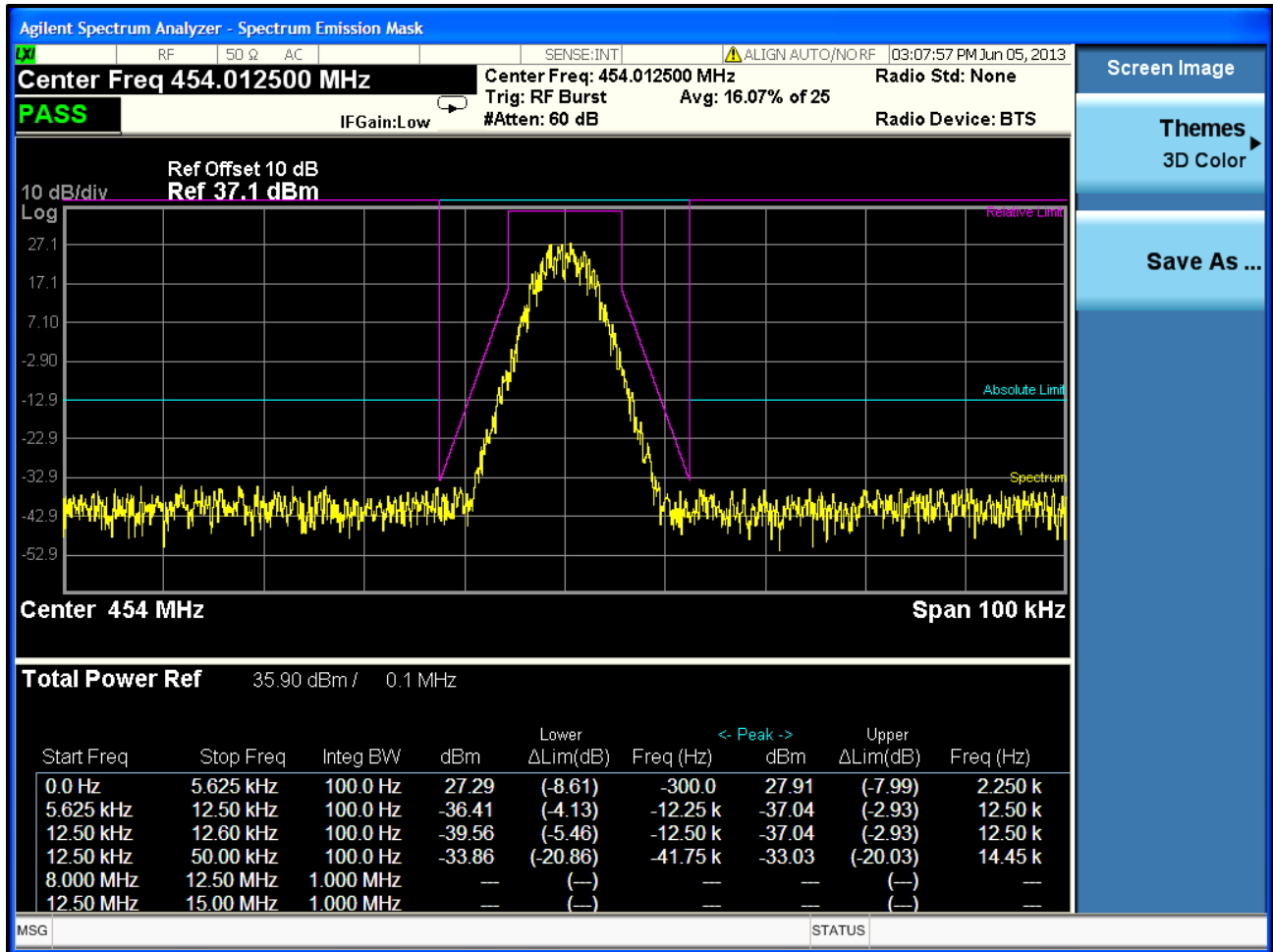

Plot 7-41: Occupied Bandwidth – 456.0125 MHz; Narrowband P25 Ph2; Mask D

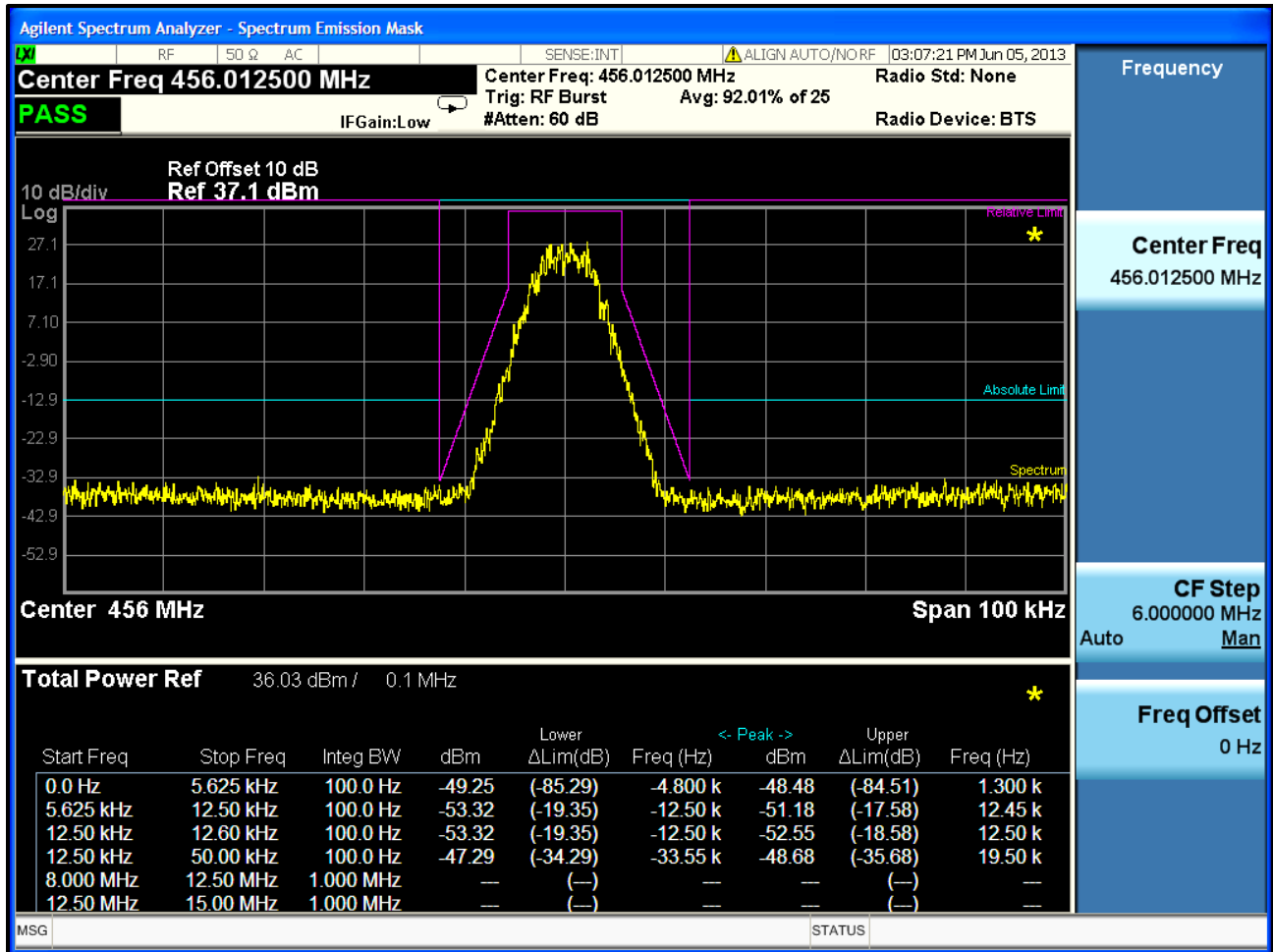

Plot 7-42: Occupied Bandwidth – 458.9875 MHz; Narrowband P25 Ph2; Mask D

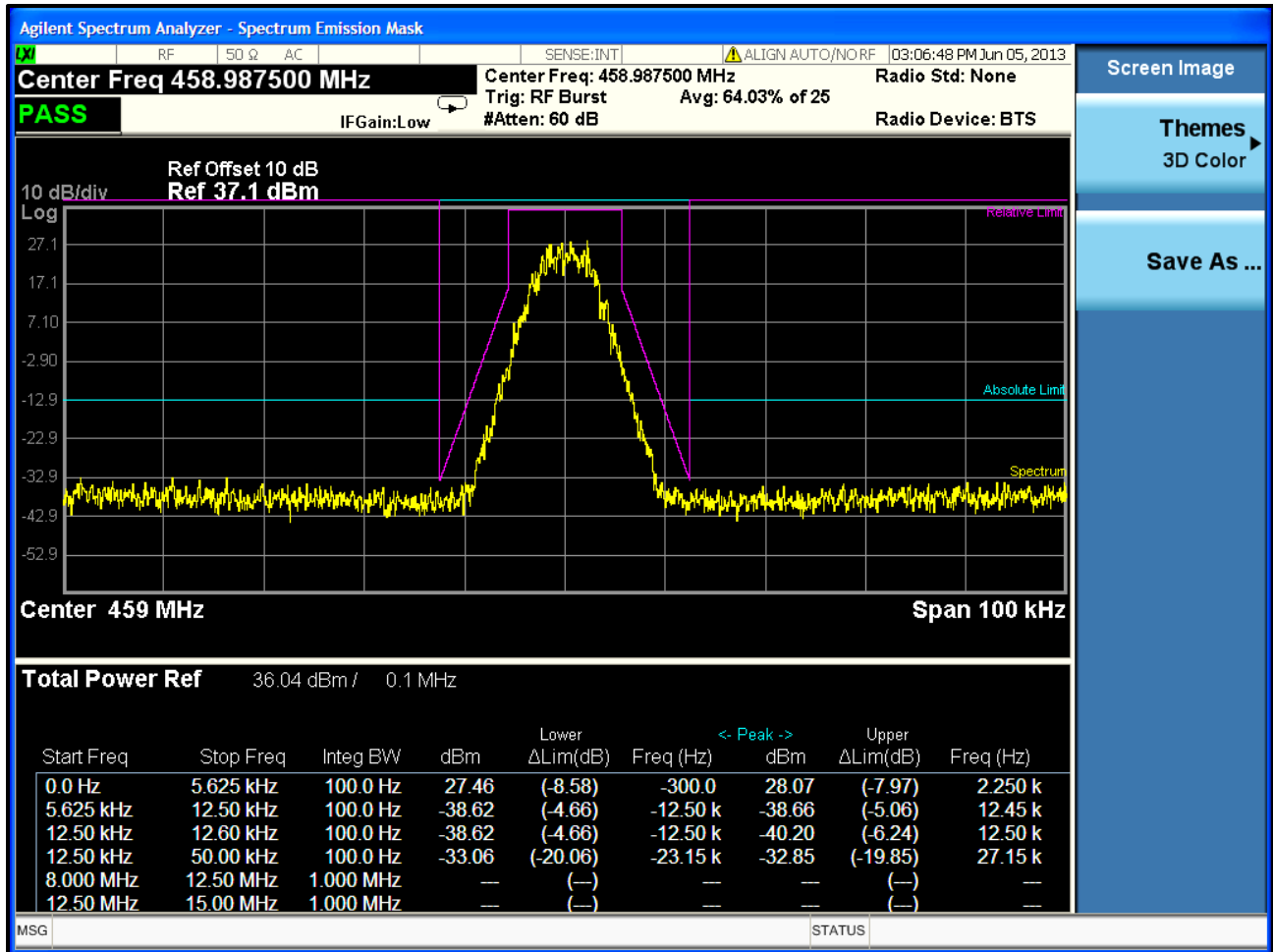

Plot 7-43: Occupied Bandwidth – 459.0250 MHz; Narrowband P25 Ph2; Mask D

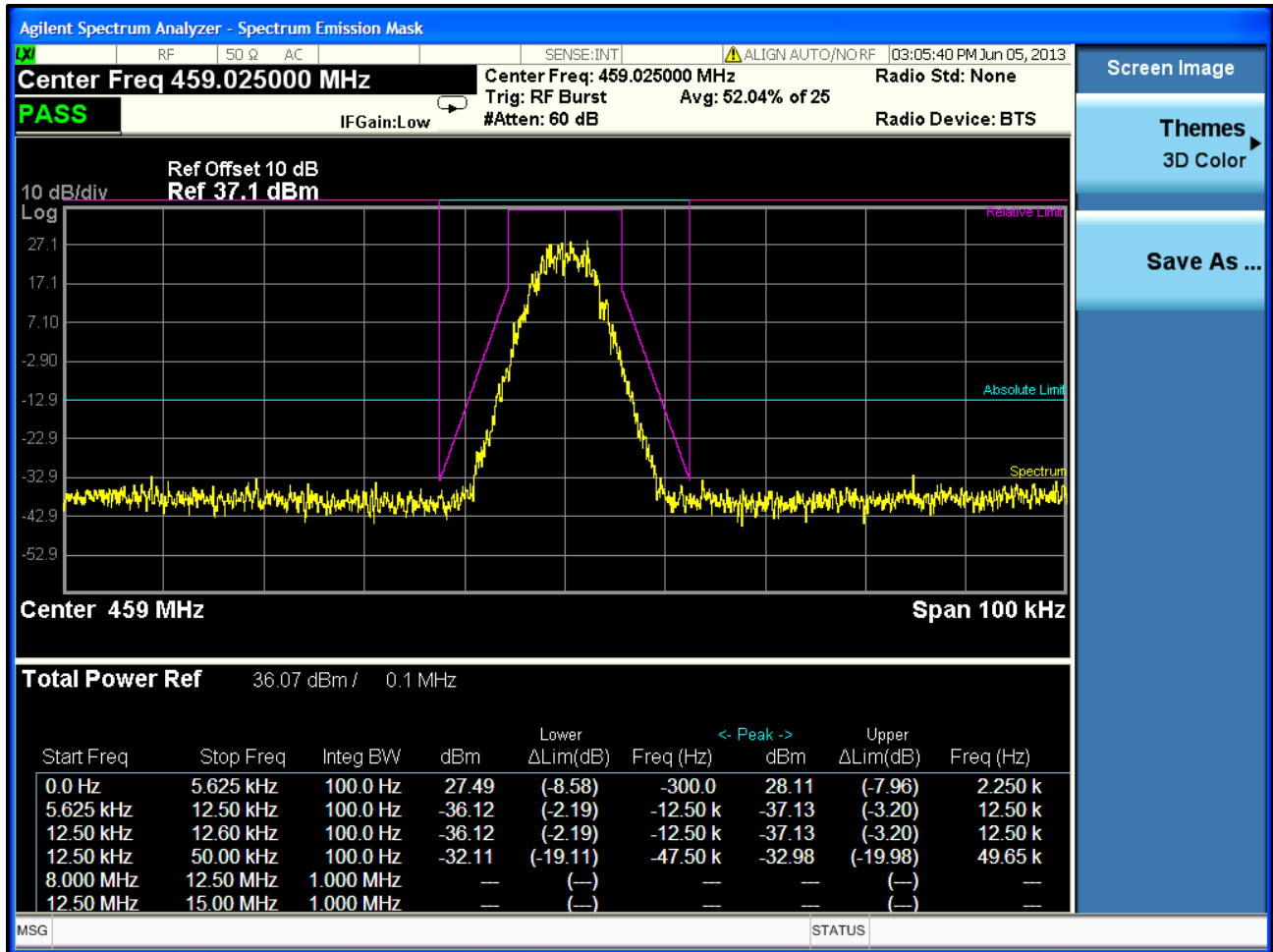

Plot 7-44: Occupied Bandwidth – 459.9750 MHz; Narrowband P25 Ph2; Mask D

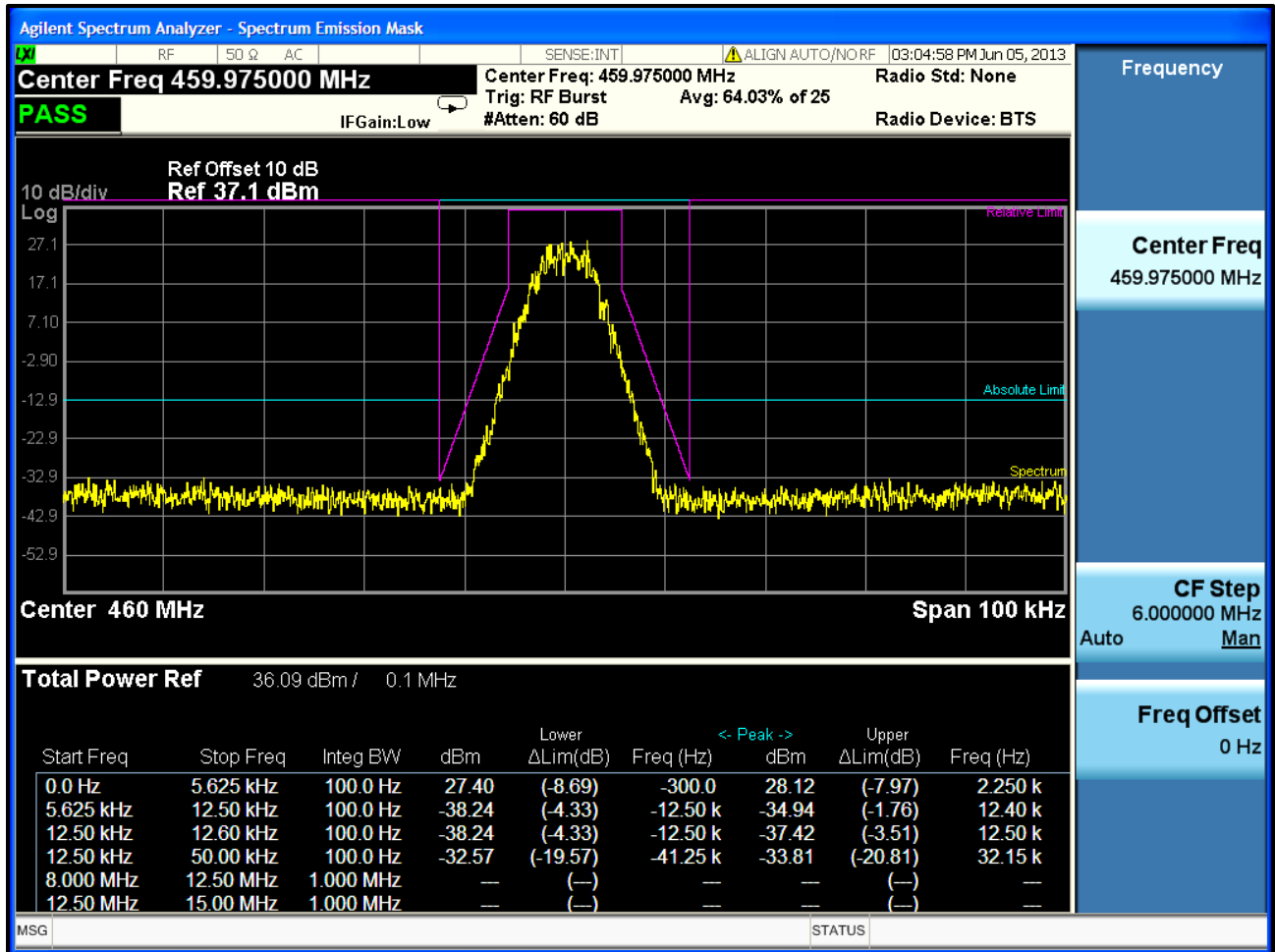

Plot 7-45: Occupied Bandwidth – 469.9875 MHz; Narrowband P25 Ph2; Mask D

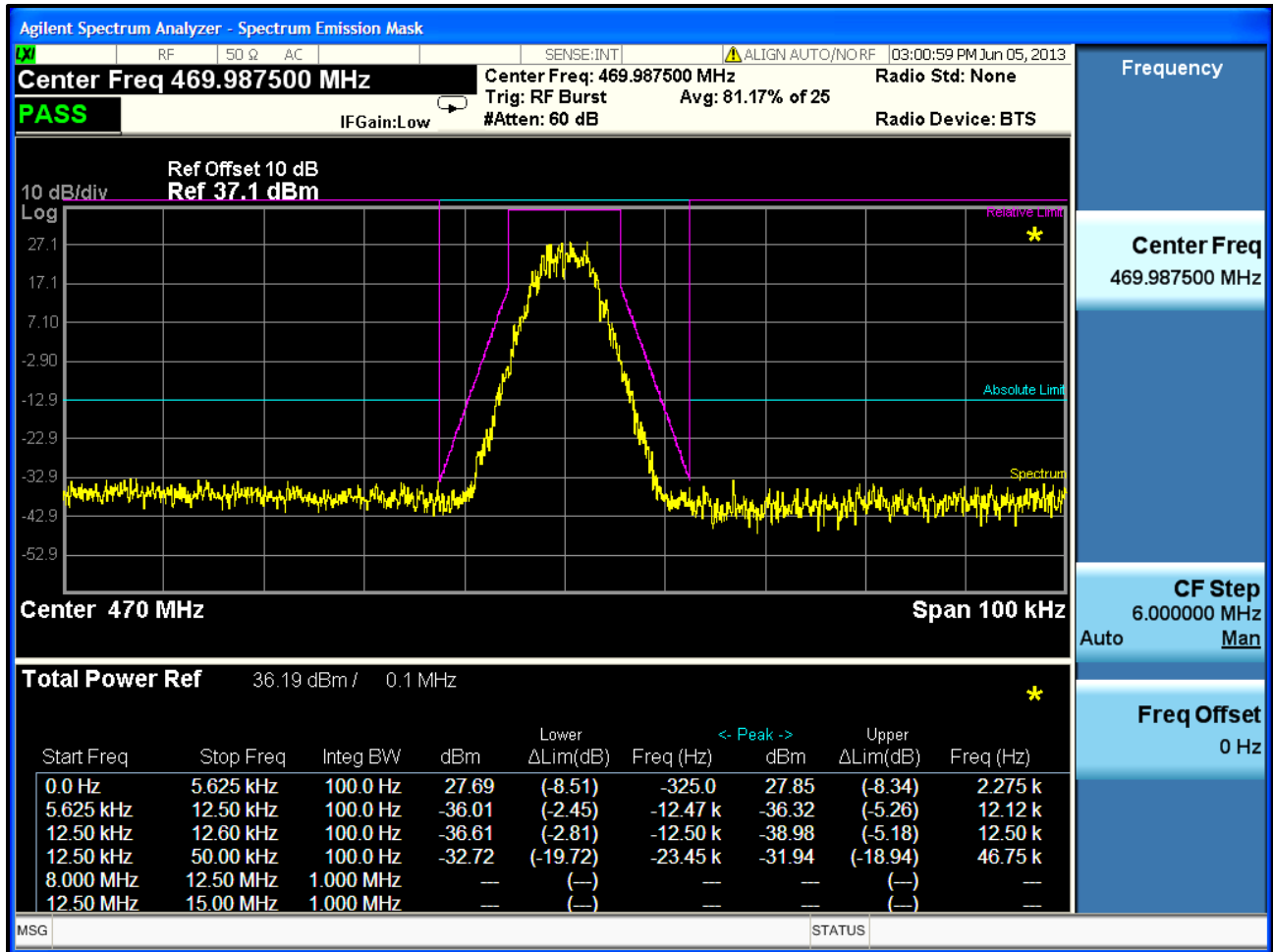

Plot 7-46: Occupied Bandwidth – 378.0125 MHz; Narrowband P25; Mask D

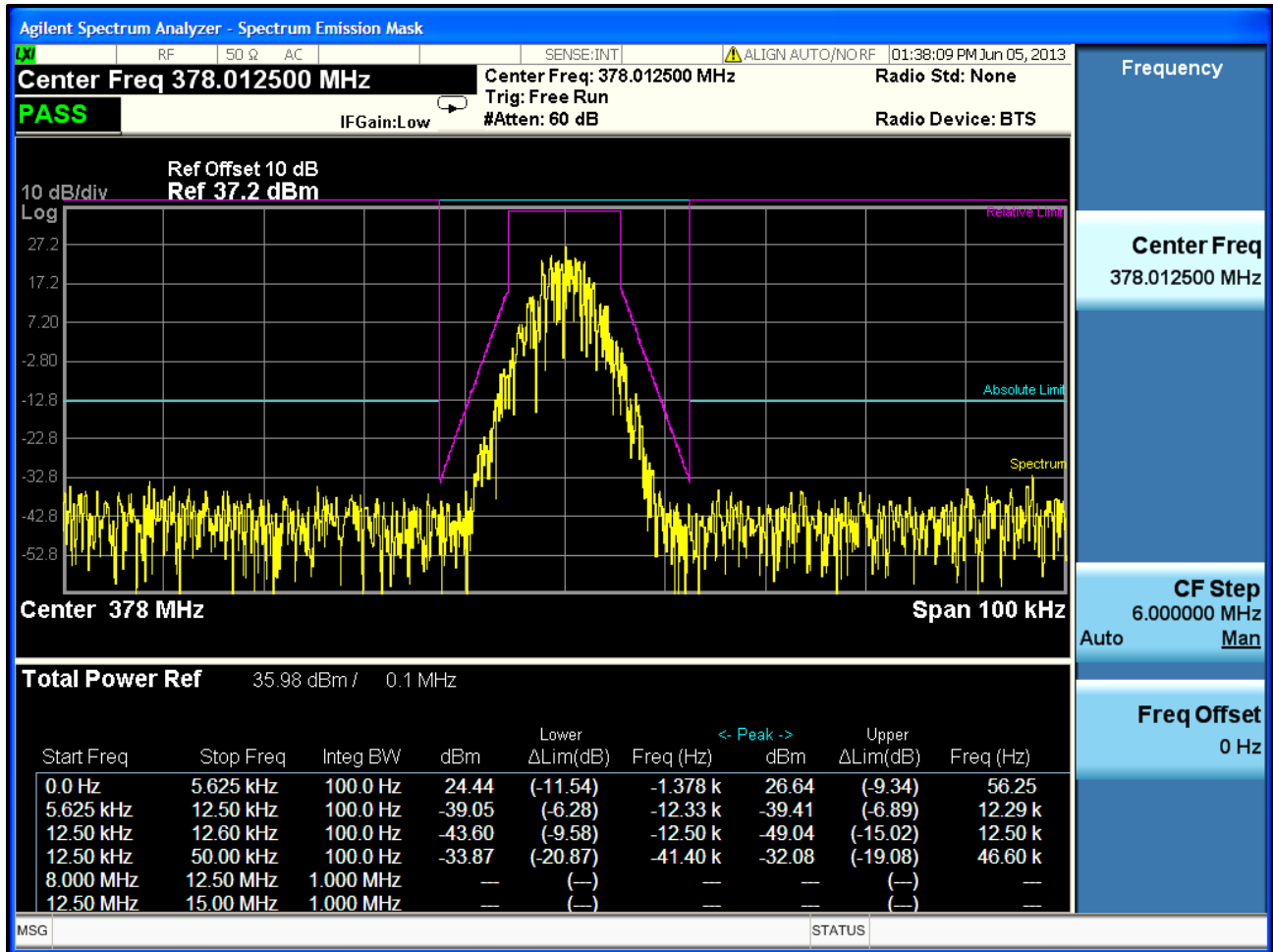

Plot 7-47: Occupied Bandwidth – 406.1125 MHz; Narrowband P25; Mask D

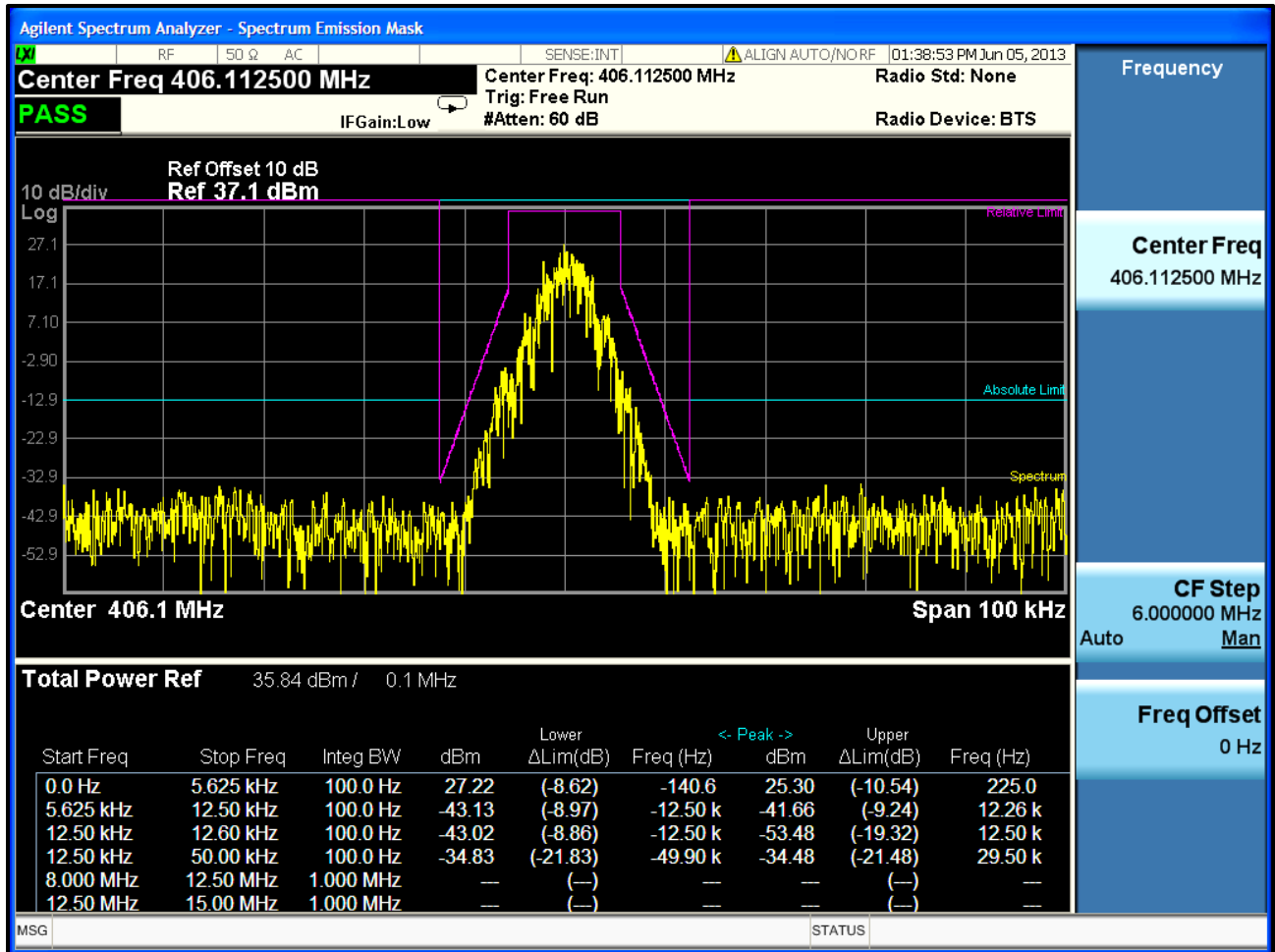

Plot 7-48: Occupied Bandwidth – 418.0000 MHz; Narrowband P25; Mask D

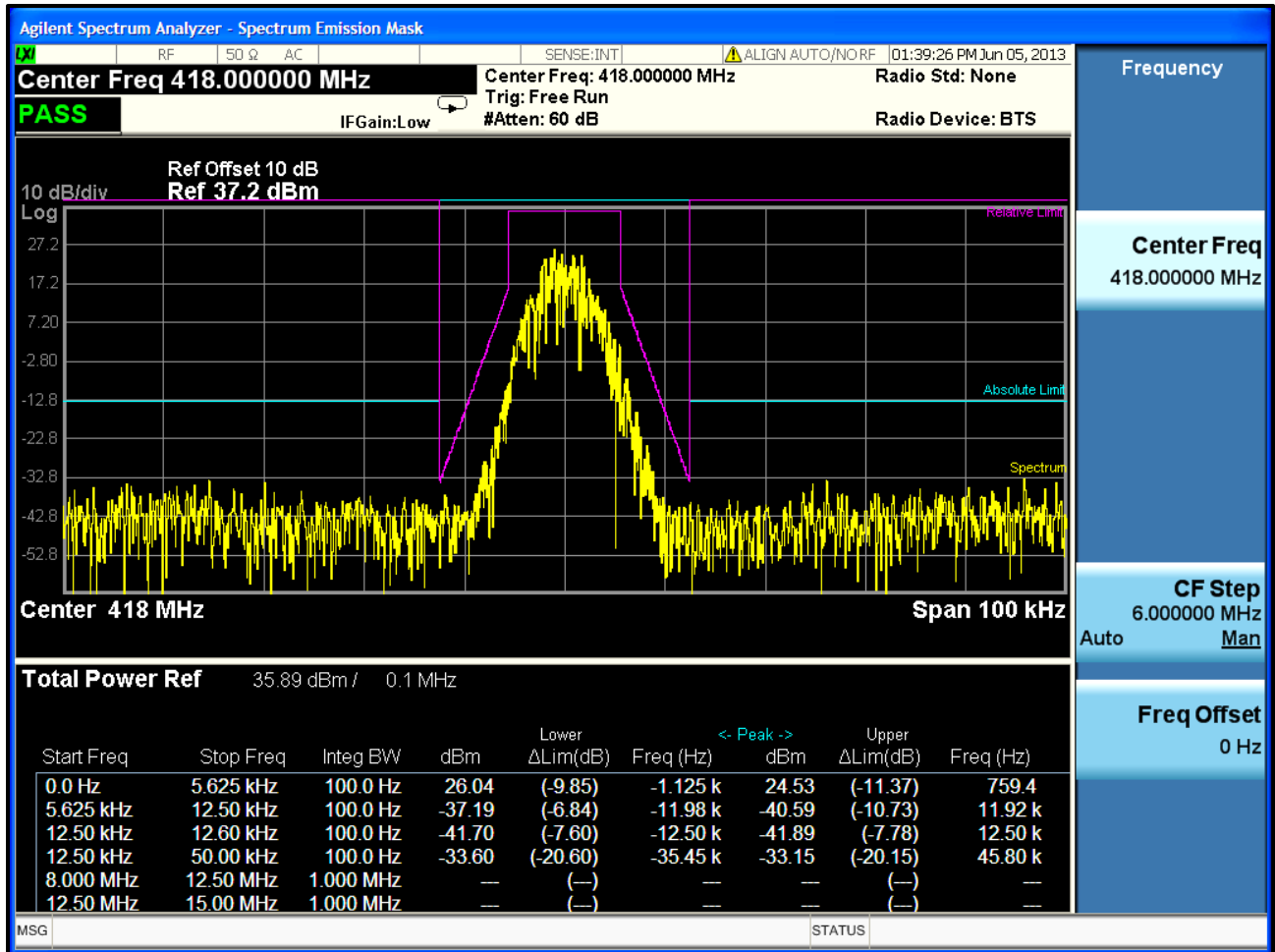

Plot 7-49: Occupied Bandwidth – 429.9875 MHz; Narrowband P25; Mask D

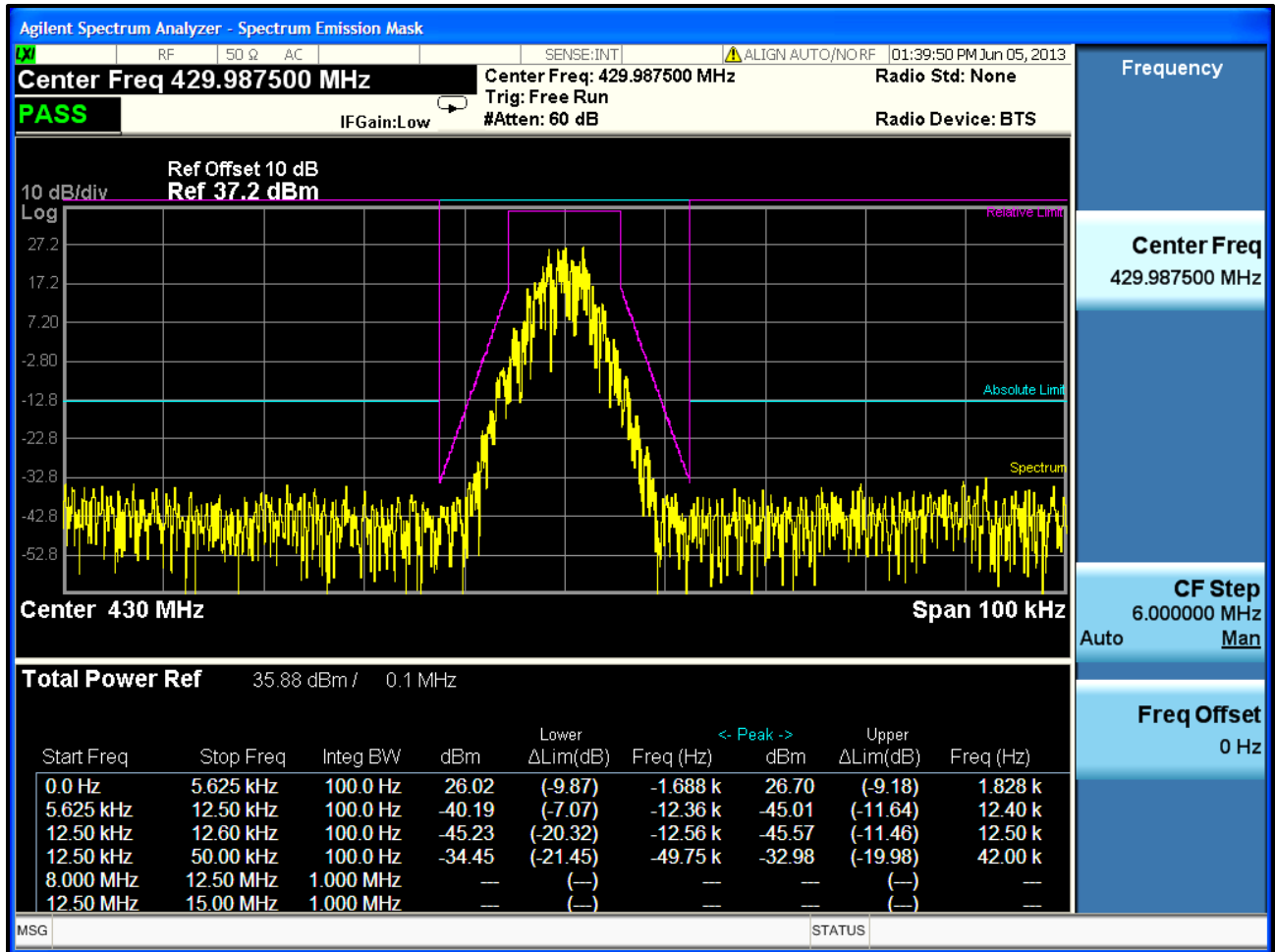

Plot 7-50: Occupied Bandwidth – 450.0125 MHz; Narrowband P25; Mask D

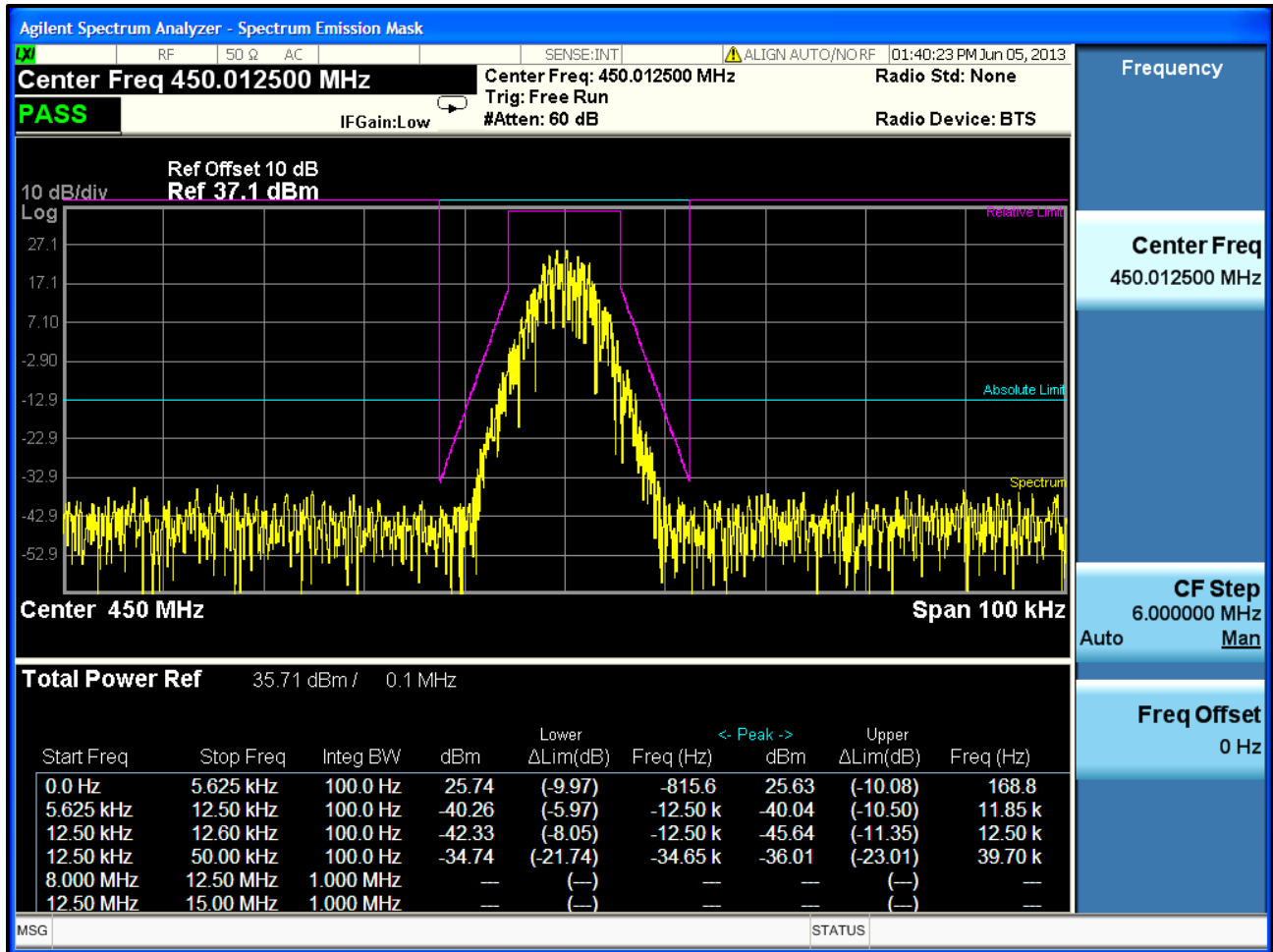

Plot 7-51: Occupied Bandwidth – 454.0125 MHz; Narrowband P25; Mask D

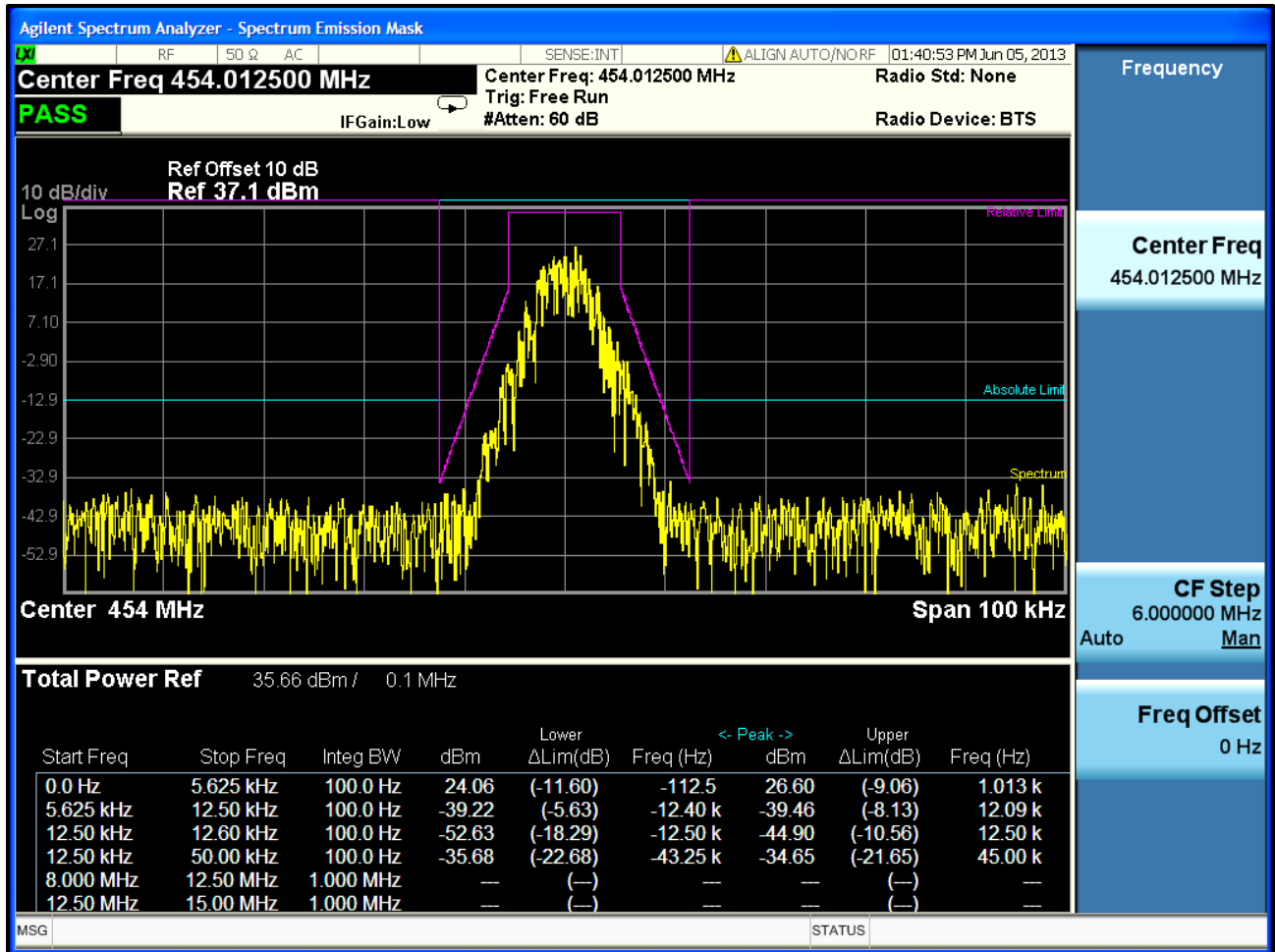

Plot 7-52: Occupied Bandwidth – 456.0125 MHz; Narrowband P25; Mask D

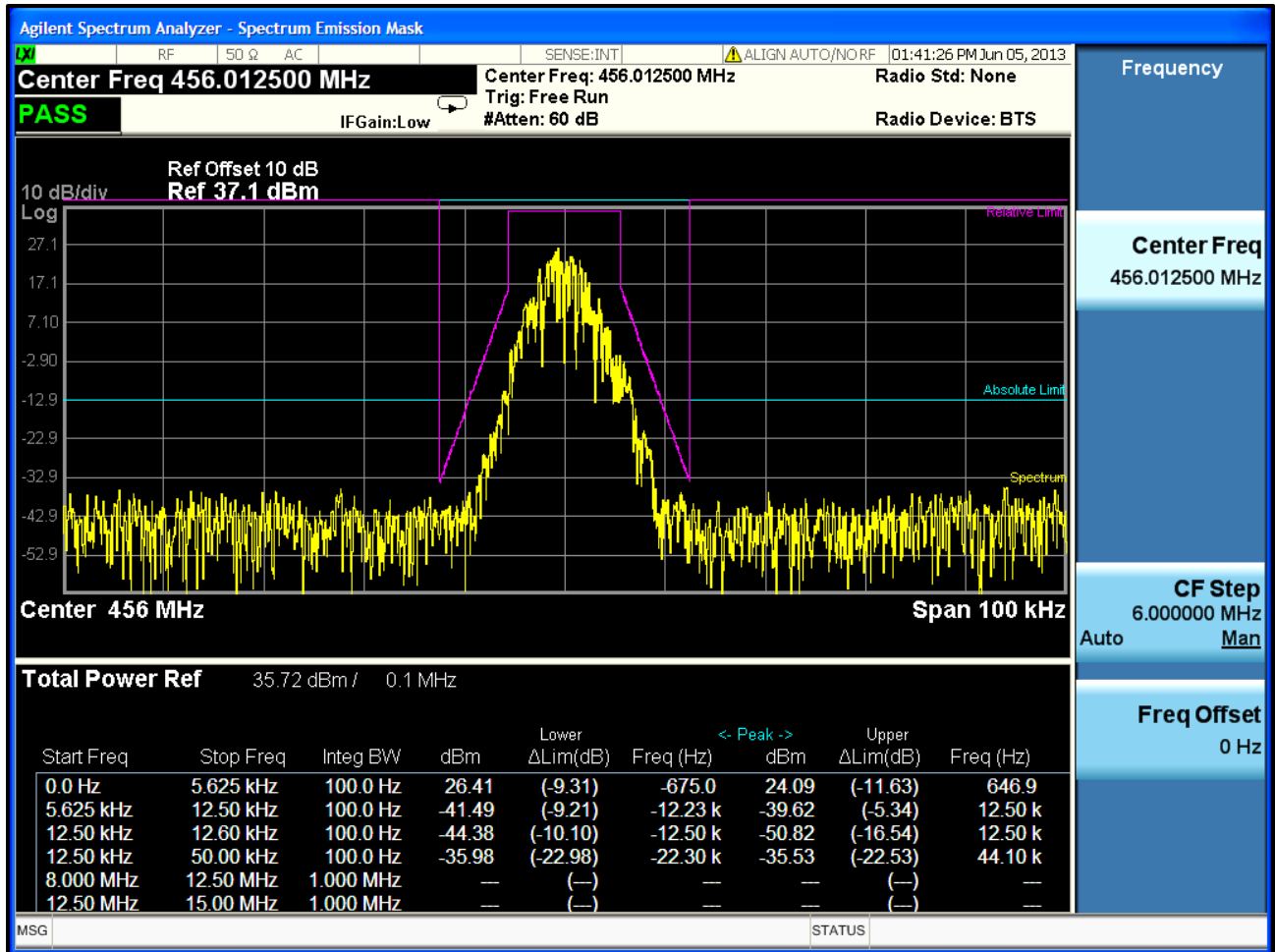

Plot 7-53: Occupied Bandwidth – 458.9875 MHz; Narrowband P25; Mask D

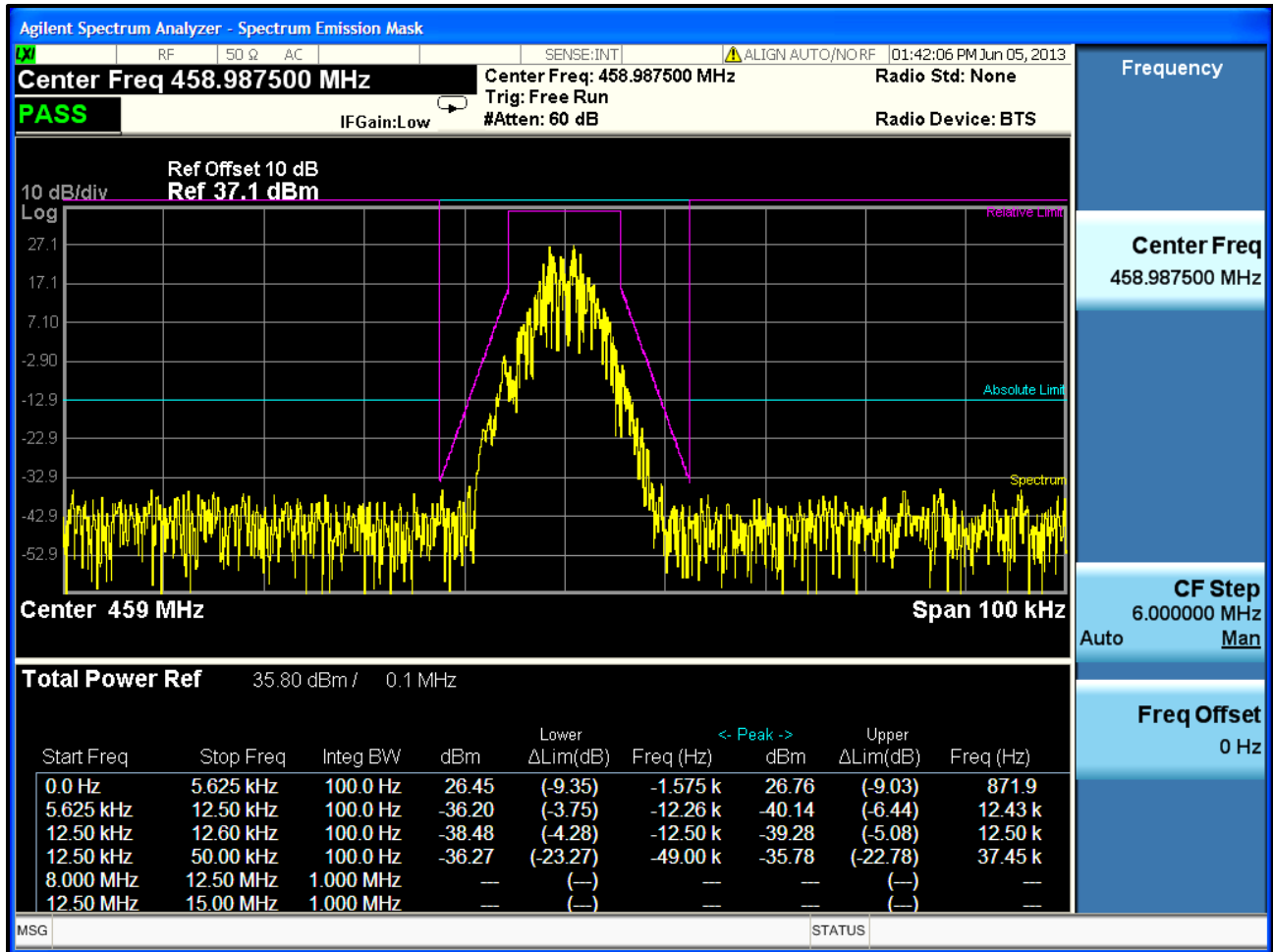

Plot 7-54: Occupied Bandwidth – 459.0250 MHz; Narrowband P25; Mask D

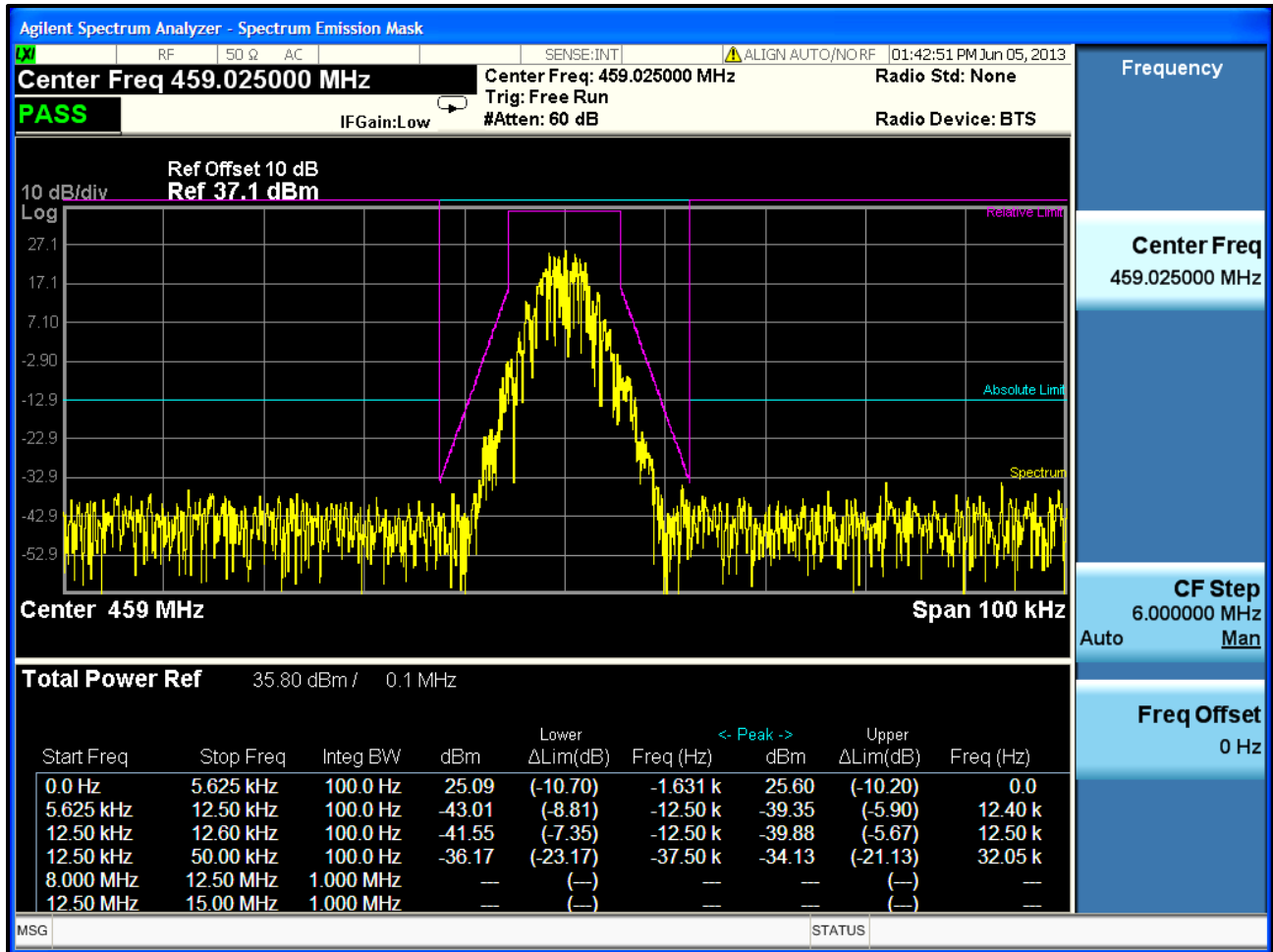

Plot 7-55: Occupied Bandwidth – 459.9750 MHz; Narrowband P25; Mask D

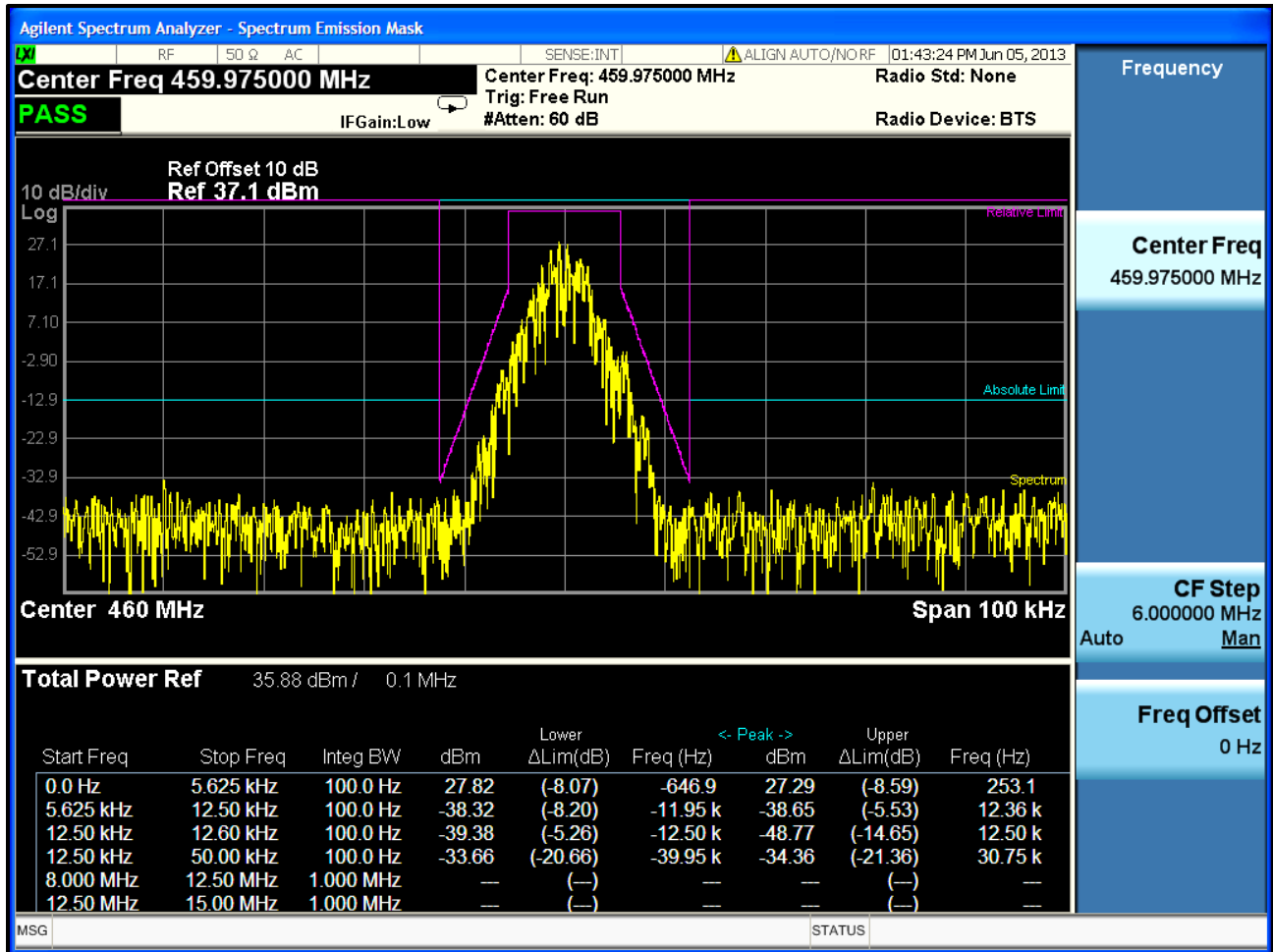

Plot 7-56: Occupied Bandwidth – 469.9875 MHz; Narrowband P25; Mask D

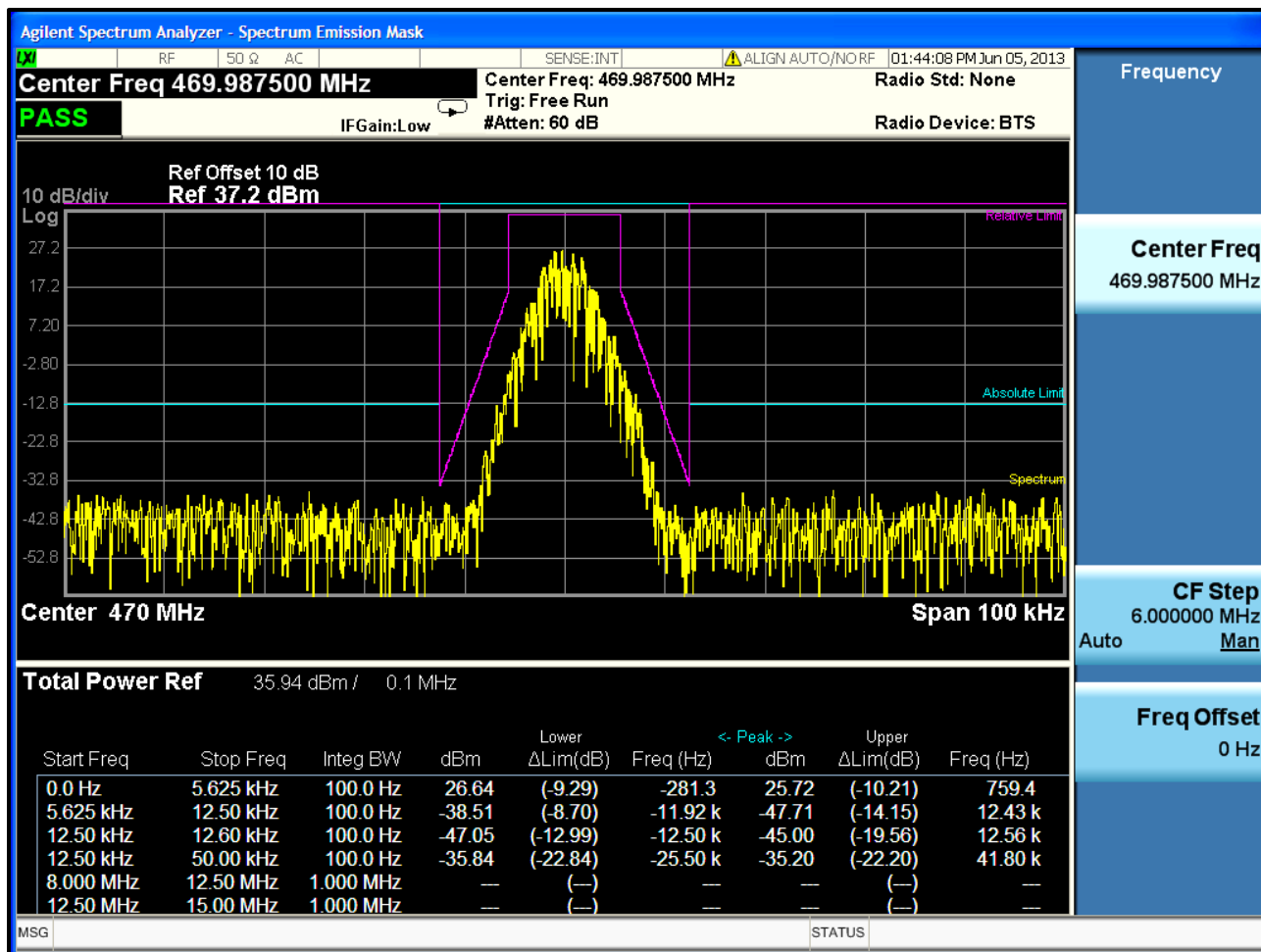

Table 7-1: Test Equipment Used For Testing Occupied Bandwidth

RTL Asset #	Manufacturer	Model	Part Type	Serial Number	Calibration Due Date
901583	Agilent Technologies	N9010A	EXA Signal Analyzer (10 Hz - 26.5 GHz)	MY51250846	4/16/14
900819	Weinschel Corp	2	10 dB Attenuator; 5 W	BF0830	3/18/14
901057	Hewlett Packard	3336B	Synthesizer/ Level Generator	2514A02585	4/17/15

Rhein Tech Laboratories, Inc.
360 Herndon Parkway
Suite 1400
Herndon, VA20170
<http://www.rheintech.com>

Client: Harris Corporation
Model: XG-25P UHF-L
ID's: OWDTR-0141-E/3636B-0141
Standards: FCC Part 22, 80, 90/IC RSS-119
Report #: 2015075TNF

Test Personnel:

Daniel Baltzell
Test Engineer



Signature

June 5 & 7, 2013
Dates of Tests

8 FCC Part 2.1055, 22.355, 80.209, 90.213; IC RSS-119 5.3: Frequency Stability

8.1 Test Procedure

TIA-603-D Section 2.2.2

The carrier frequency stability is the ability of the transmitter to maintain an assigned carrier frequency.

The EUT was evaluated over the temperature range -30°C to +60°C.

The temperature was initially set to -30°C and a 1-hour period was observed for stabilization of the EUT. The frequency stability was measured within one minute after application of primary power to the transmitter. The temperature was raised at intervals of 10 degrees centigrade through the range. A ½-hour period was observed to stabilize the EUT at each measurement step and the frequency stability was measured within one minute after application of primary power to the transmitter. Additionally, the power supply voltage of the EUT was varied +/-15% nominal input voltage.

Part 22.355 and 90.213: Mobile stations over 2 W operating power - 5 ppm.

80.209(a)(7) Band 400–466 MHz: 5ppm.

Part 90.213 Frequency Stability

(a) Unless noted elsewhere, transmitters used in the services governed by this part must have a minimum frequency stability as specified in the following table.

MINIMUM FREQUENCY STABILITY [Parts per million (ppm)]			
Frequency range (MHz)	Fixed and base stations	Mobile stations	
		Over 2 watts output power	2 watts or less output power
Below 25	^{1,2,3} 100	100	200
25-50	20	20	50
72-76	5	50
150-174	^{5,11} 5	65	^{4,6} 50
216-220	1.0	1.0
220-222 ¹²	0.1	1.5	1.5
421-512	^{7,11,14} 2.5	⁸ 5	⁸ 5
806-809	¹⁴ 1.0	1.5	1.5
809-824	¹⁴ 1.5	2.5	2.5
851-854	1.0	1.5	1.5
854-869	1.5	2.5	2.5
896-901	¹⁴ 0.1	1.5	1.5
902-928	2.5	2.5	2.5
902-928 ¹³	2.5	2.5	2.5
929-930	1.5
935-940	0.1	1.5	1.5
1427-1435	⁹ 300	300	300
Above 2450 ¹⁰

8.2 Test Data

8.2.1 Temperature Frequency Stability

Table 8-1: Temperature Frequency Stability – 406.1125 MHz

Temperature (°C)	Measured Frequency (Hz)	ppm
-30	406112426	-0.18
-20	406112424	-0.19
-10	406112439	-0.15
0	406112424	-0.19
10	406112403	-0.24
20 (reference)	406112500	0.00
30	406112488	-0.03
40	406112498	0.00
50	406112485	-0.04
60	406112465	-0.09

Table 8-2: Temperature Frequency Stability – 459.9750 MHz

Temperature (°C)	Measured Frequency (Hz)	ppm
-30	459974915	-0.18
-20	459974914	-0.19
-10	459974933	-0.15
0	459974912	-0.19
10	459974890	-0.24
20 (reference)	459975000	0.00
30	459974986	-0.03
40	459974999	0.00
50	459974983	-0.04
60	459974957	-0.09

Results: The EUT is compliant.

Table 8-3: Test Equipment Used For Testing Frequency Stability

RTL Asset #	Manufacturer	Model	Part Type	Serial Number	Calibration Due Date
900946	Tenney Engineering, Inc.	TH65	Temperature Chamber with Humidity	11380	1/13/14
901300	Agilent Technologies	53131A	Frequency Counter	MY40001345	7/18/13
901337	Narda Microline	766-10	Attenuator, DC-4GHz, 10 dB, 20W	6242	8/17/13
901350	Meterman	33XR	Multimeter	040402802	3/20/15

Test Personnel:

Daniel Baltzell
Test Engineer

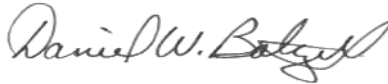

Signature

June 5, 2013
Date of Tests

8.2.2 Frequency Stability/Voltage Variation

Table 8-4: Frequency Stability/Voltage Variation – 406.1125 MHz

Voltage (VDC)	Measured Frequency (Hz)	ppm
5.22 (end of battery)	406112499	0.00
6.375	406112501	0.00
7.5 (reference)	406112500	0.00
8.625	406112500	0.00

Table 8-5: Frequency Stability/Voltage Variation – 459.9750 MHz

Voltage (VDC)	Measured Frequency (Hz)	ppm
5.23 (end of battery)	459975002	0.00
6.375	459975002	0.00
7.5 (reference)	459975000	0.00
8.625	459974998	0.00

Table 8-6: Test Equipment Used For Testing Frequency Stability

RTL Asset #	Manufacturer	Model	Part Type	Serial Number	Calibration Due Date
900946	Tenney Engineering, Inc.	TH65	Temperature Chamber with Humidity	11380	1/13/14
901300	Agilent Technologies	53131A	Frequency Counter	MY40001345	7/18/13
901337	Narda Microline	766-10	Attenuator, DC-4GHz, 10 dB, 20W	6242	8/17/13
901350	Meterman	33XR	Multimeter	040402802	3/20/15

Test Personnel:

Daniel Baltzell
 EMC Test Engineer



Signature

June 5, 2013
 Date of Test

9 FCC Part 2.1047(a)(b), 80.213; IC RSS-119 5.8: Modulation Characteristics

9.1 Test Procedures

9.1.1 Audio Frequency Response

TIA-603-D 2010 Section 2.2.6

The audio frequency response is the degree of closeness to which the frequency deviation of the transmitter follows a prescribed characteristic.

The input audio level at 1000 Hz was set to produce 20% of the rated system deviation. This point is shown as the 0 dB reference level, noted DEVref. The audio signal generator was varied from 100 Hz to 5 kHz with the input level held constant. The deviation in kHz was recorded using a modulation analyzer as DEVfreq. The response in dB relative to 1 kHz was calculated as follows:

Audio Frequency Response = 20 LOG (DEVfreq/DEVref)

9.1.2 Audio Low Pass Filter Response

TIA-603-D 2010 Section 2.2.15

The Audio Low Pass Filter Response is the frequency response of the post limiter low pass filter circuit above 3000 Hz.

9.1.3 Modulation Limiting

TIA-603-D 2010 Section 2.2.3

The transmitter was adjusted for full rated system deviation. The audio input level was adjusted for 60% of rated system deviation at 1000 Hz. Using this level (0 dB) as a reference, the audio input level was varied from the reference +/-20 dB for modulation frequencies of 300 Hz, 1,000 Hz, and 2,500 Hz. The system deviation obtained as a function of the input level was recorded. Both positive and negative peak deviations were recorded.

9.2 Test Data

9.2.1 Audio Frequency Response

Plot 9-1: Modulation Characteristics - Audio Frequency Response – 450.0125 MHz

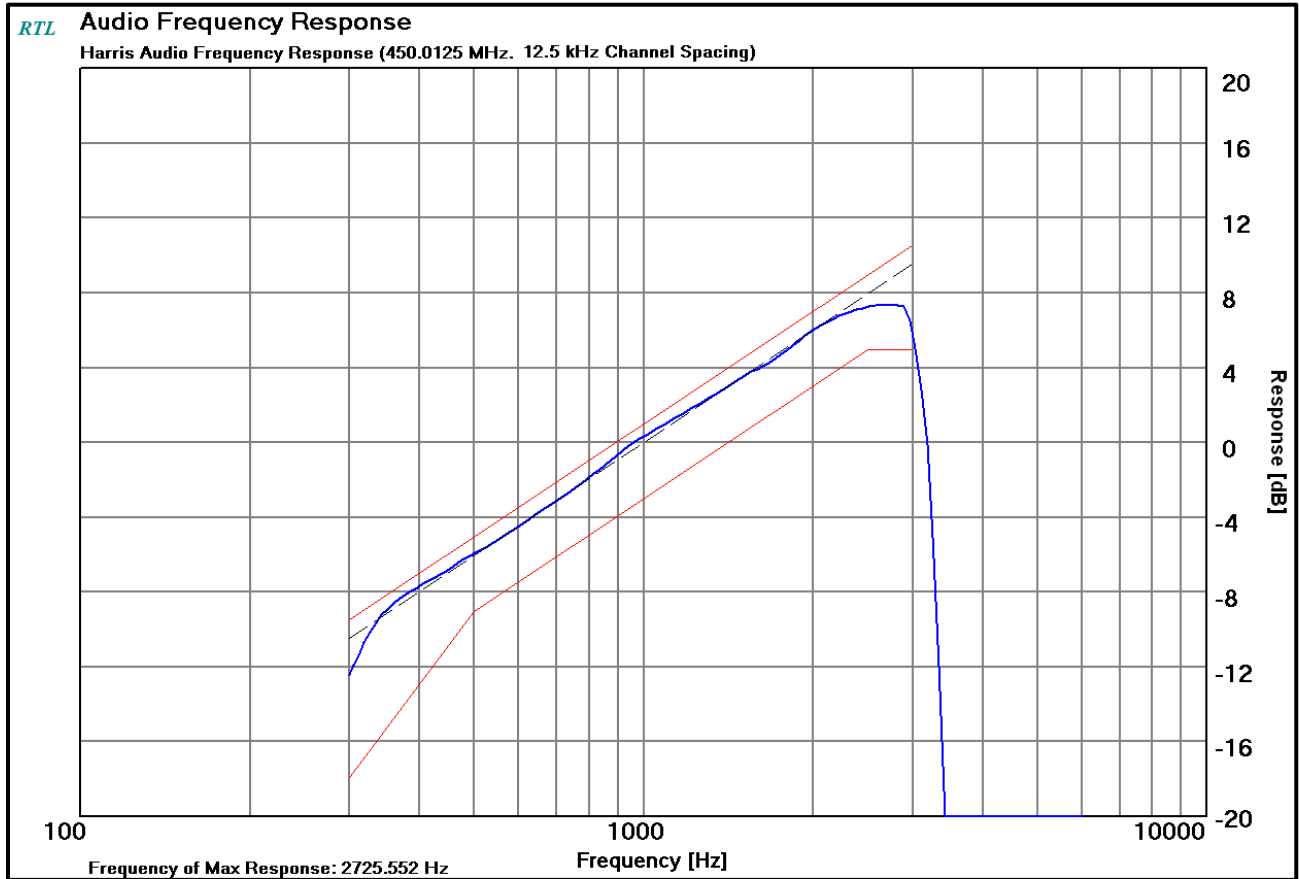

9.2.2 Audio Low Pass Filter Response

Plot 9-2: Modulation Characteristics – Audio Low Pass Filter – 450.0125 MHz

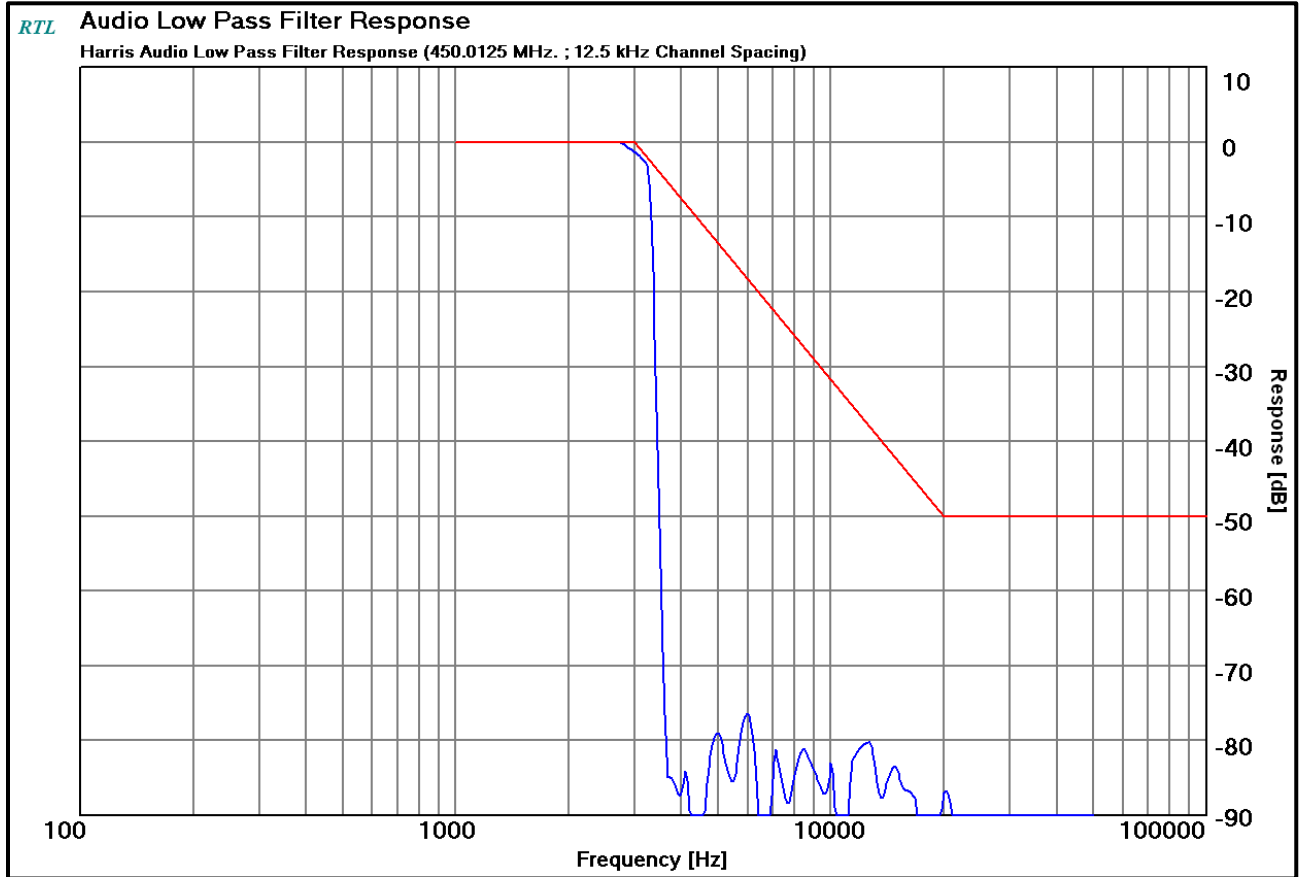

9.2.3 Modulation Limiting

Plot 9-3: Modulation Characteristics – Modulation Limiting – 450.0125 MHz; NB, Positive Peak

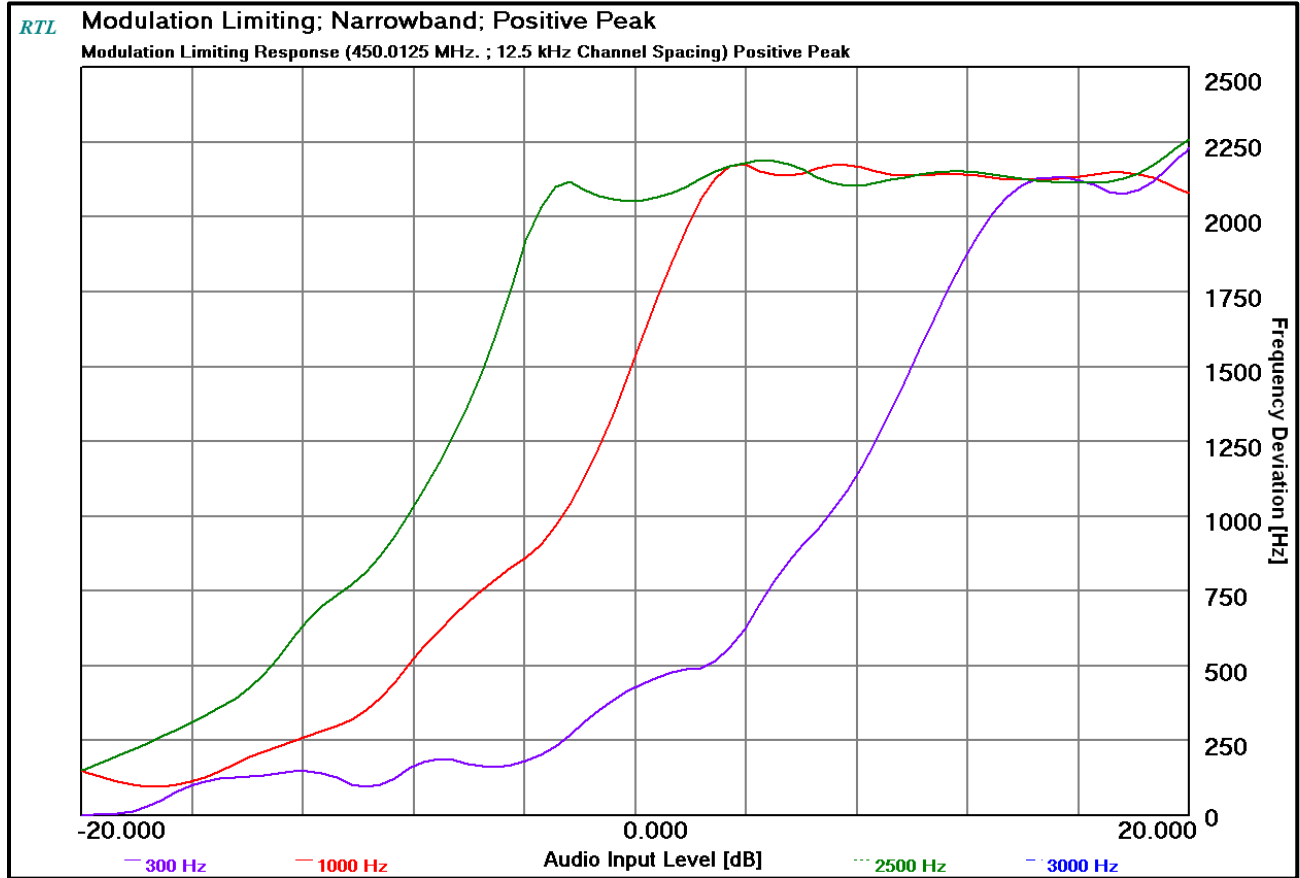

Plot 9-4: Modulation Characteristics – Modulation Limiting - 450.0125 MHz; NB, Negative Peak

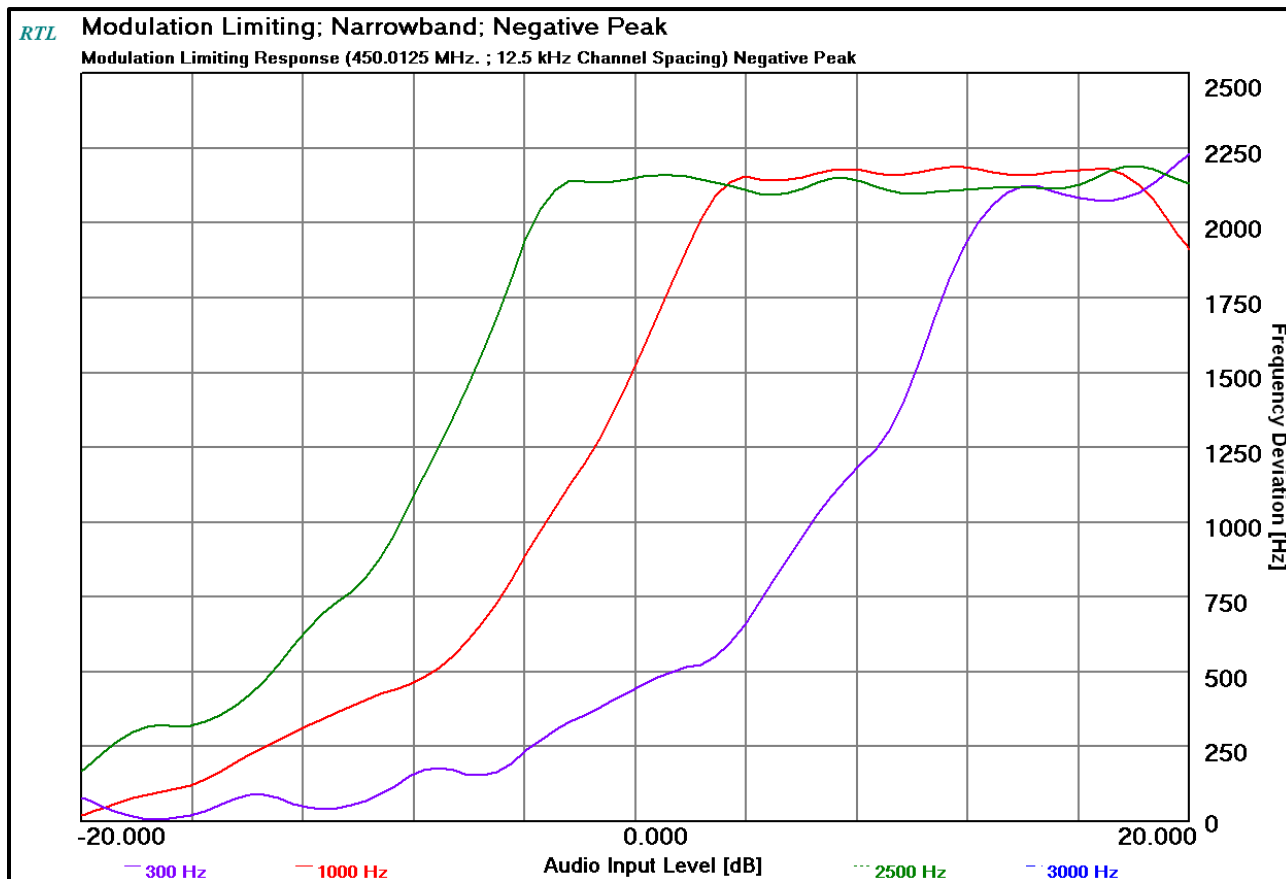

Table 9-1: Test Equipment Used For Testing Modulation Requirements

RTL Asset #	Manufacturer	Model	Part Type	Serial Number	Calibration Due Date
901057	Hewlett Packard	3336B	Synthesizer/ Level Generator	2514A02585	4/17/15
901118	Hewlett Packard	8901A Opt. 002-003	Modulation Analyzer	2406A00178	4/1/15
901337	Narda Microline	766-10	Attenuator, DC-4GHz, 10 dB, 20W	6242	8/17/13

Test Personnel:

Daniel Baltzell
 Test Engineer

Signature

June 5, 2013
 Date of Tests

10 FCC Part 2.202: Necessary Bandwidth and Emission Bandwidth

Voice – 12.5 kHz channel separation

Calculation:

Max modulation (M) in kHz: 3.0

Max deviation (D) in kHz: 2.5

Constant factor (K): 1

$B_n = 2 \times M + 2 \times D \times K = 11.0 \text{ kHz}$

Emission designator: 11K0F3E

P25 – 9600 bps

Calculation:

Data rate in bps (R) = 9600

Peak deviation of carrier (D) = 1800

$B_n = [9600 / \log_2(4) + 2(1800)(1)] = 8.4 \text{ kHz}$

Emission designator: 8K40F1D, 8K40F1E

EDACS XNB 9600 digital voice/data (12.5 kHz)

Calculation:

Data rate in bps (R) = 9600

Deviation Peak deviation of carrier (D) = 2359.585

Constant factor (K): 1 (default)

$B_n = 3.86D + 0.27RK = 3.86(2359.585) + 0.27(9600)(1) = 11.7 \text{ kHz}$

Emission designator: 11K7F1E/D

EDACS XNB 4800 digital voice/data (12.5 kHz)

Calculation:

Data rate in bps (R) = 4800

Deviation Peak deviation of carrier (D) = 1503.626

Constant factor (K): 1 (default)

$B_n = 3.86D + 0.27RK = 3.86(1503.626) + 0.27(4800)(1) = 7.1 \text{ kHz}$

Emission designator: 7K10F1E/D

P25 Phase 2 data/voice (H-CPM TDMA)

Calculation:

Data rate in bps (R) = 12000

Peak deviation of carrier (D) = 1050

$B_n = [12000 / \log_2(4) + 2(1050)(1)] = 8.1 \text{ kHz}$

Emission designator: 8K10DXW

11 Conclusion

The data in this measurement report shows that the Harris Corporation Model XG-25P UHF-L Portable Radio family, Models DPXG-PFU1B-e1 and DPXG-PBU1B-e1, FCC ID: OWDTR-0141-E, IC: 3636B-0141, comply with the applicable requirements of Parts 90, 80, 22 and 2 of the FCC Rules and Industry Canada RSS-119.