



Engineering Solutions & Electromagnetic Compatibility Services

FCC Part 15.247 & IC RSS-210 Certification Report

Harris Corporation
1680 University Avenue
Rochester, NY 14610

Model: XG-25P UHF-L MHz

FCC ID: OWDTR-0109-E
IC: 3636B-0109

June 14, 2013

Standards Referenced for this Report	
American National Standard Institute	ANSI C63.4-2003: Methods of Measurement of Radio-Noise Emissions from Low-Voltage Electrical and Electronic Equipment in the Range of 9 kHz to 40 GHz
FCC Classification	DSS – Part 15 Spread Spectrum Transmitter
FCC Rule Part(s)	FCC Rules Part 15.247: Operation within the bands 920-928 MHz, 2400-2483.5 MHz and 5725-5850 MHz Frequency Hopping System (10-01-10)
IC Standard	RSS-210 Issue 8: Licence-exempt Radio Apparatus (All Frequency Bands): Category I Equipment
FCC Procedure	ANSI C63.10-2009: American National Standard for Testing Unlicensed Wireless Devices
Digital Interface Information	Digital Interface was found to be compliant

Frequency Range (MHz)	Rated Transmit Power (W) (Conducted)	Frequency Tolerance (ppm)	Emission Designator
2402 – 2480	0.002	N/A	1M01FXD
2402 – 2480	0.002	N/A	1M33GXD

Report Prepared By: Dan Baltzell

Document Number: 2013062DSS

This report may not be reproduced, except in full, without the full written approval of Rhein Tech Laboratories, Inc. and Harris Corporation. Test results relate only to the item tested.

These tests are accredited and meet the requirements of ISO/IEC 17025 as verified by ANSI-ASQ National Accreditation Board/ACLASS. Refer to certificate and scope of accreditation AT-1445.

Table of Contents

1	General Information	5
1.1	Scope	5
1.2	Description of EUT	5
1.3	Test Facility	5
1.4	Related Submittal(s)/Grant(s)	5
1.5	Modifications	5
1.6	Grant Notes	5
2	Test Information	6
2.1	Description of Test Modes	6
2.2	Exercising the EUT	6
2.3	Test Result Summary.....	6
2.4	Tested System Details	7
3	Peak Output Power – FCC 15.247(b)(1), RSS-210 A8.4(2), RSS-Gen 4.8	8
3.1	Power Output Test Procedure	8
3.2	Power Output Test Data.....	8
4	Antenna Conducted Spurious Emissions – FCC 15.247(d), RSS-210 A8.5	9
5	Band-Edge Compliance of RF Conducted Emissions – FCC 15.247(d), RSS-210 A8.5.....	13
5.1	Band Edge Test Procedure.....	13
5.2	Test Results	14
5.3	Radiated Band Edge Emissions	16
6	20 dB Bandwidth – FCC 15.247(a)(1), RSS-210 A8.1(a).....	17
6.1	20 dB Bandwidth Test Procedure	17
6.2	20 dB Modulated Bandwidth Test Data	17
6.3	20 dB Bandwidth Plots	18
7	Carrier Frequency Separation - 15.247(a)(1), RSS-210 A8.1(b).....	24
7.1	Carrier Frequency Separation Test Procedure.....	24
7.2	Carrier Frequency Separation Test Data	24
8	Hopping Characteristics – FCC 15.247(a)(1)(iii), RSS-210 A8.1(d).....	25
8.1	Hopping Characteristics Test Procedure	25
8.2	Number of Hopping Frequencies	25
8.3	Average Time of Occupancy.....	26
9	Radiated Emissions Test Results - FCC Rules and Regulations Part 15.247(d).....	28
9.1	Limits of Radiated Emissions Measurement.....	28
9.2	Radiated Emissions Measurement Test Procedure	28
9.2.1	Radiated Emissions Harmonics/Spurious Test Data	29
10	Conclusion	32

Figure Index

Figure 2-1: Configuration of Tested System.....	7
---	---

Table Index

Table 2-1: Channels Tested	6
Table 2-2: Test Result Summary – FCC Part 15, Subpart C (Section 15.247).....	6
Table 2-3: Equipment Under Test (EUT).....	7
Table 3-1: Power Output Test Data – High Power.....	8
Table 3-2: Power Output Test Equipment.....	8
Table 4-1: Antenna Conducted Spurious Test Equipment.....	12
Table 5-1: Band-Edge Compliance of RF Conducted Emissions Test Equipment.....	15
Table 5-2: Radiated Band Edge Emissions Test Data.....	16
Table 5-3: Radiated Band Edge Test Equipment.....	16
Table 6-1: 20 dB Modulated Bandwidth Test Data (SDR)	17
Table 6-2: 20 dB Modulated Bandwidth Test Data (EDR)	17
Table 6-3: 20 dB Bandwidth Test Equipment.....	23
Table 8-1: Hopping Characteristics Test Equipment.....	27
Table 9-1: Radiated Emissions Harmonics/Spurious - 2402 MHz	29
Table 9-2: Radiated Emissions Harmonics/Spurious - 2441 MHz	29
Table 9-3: Radiated Emissions Harmonics/Spurious - 2480 MHz	30
Table 9-4: Radiated Emissions Harmonics/Spurious – Hopping Mode	31
Table 9-5: Radiated Emissions Test Equipment	32

Plot Index

Plot 4-1: Antenna Conducted Spurious TX Frequency - 2402 MHz.....	9
Plot 4-2: Antenna Conducted Spurious TX Frequency - 2441 MHz.....	10
Plot 4-3: Antenna Conducted Spurious TX Frequency - 2480 MHz.....	11
Plot 4-4: Antenna Conducted Spurious - Hopping Mode	12
Plot 5-1: Lower Band Edge TX Frequency - 2402 MHz	14
Plot 5-2: Upper Band Edge TX Frequency - 2480 MHz	15
Plot 6-1: 20 dB Bandwidth - 2402 MHz (SDR)	18
Plot 6-2: 20 dB Bandwidth - 2441 MHz (SDR)	19
Plot 6-3: 20 dB Bandwidth - 2480 MHz (SDR)	20
Plot 6-4: 20 dB Bandwidth - 2402 MHz (EDR)	21
Plot 6-5: 20 dB Bandwidth - 2441 MHz (EDR)	22
Plot 6-6: 20 dB Bandwidth - 2480 MHz (EDR)	23
Plot 7-1: Carrier Frequency Separation.....	24
Plot 8-1: Number of Hopping Frequencies (2402 - 2480 MHz)	25
Plot 8-2: Time of Occupancy (Dwell Time).....	26
Plot 8-3: Number of Pulses in 3.16 Second Sweep	27

Appendix Index

Appendix A: RF Exposure FCC Part 1.1307, 1.1310, 2.1091, 2.1093	33
Appendix B: Test Photographs	34

Photograph Index

Photograph 1: Radiated Emissions – Front View	34
Photograph 2: Radiated Emissions – Back View.....	35

1 General Information

1.1 Scope

This is an original certification application test report.

Applicable Standards:

- FCC Rules Part 15.247: Frequency Hopping, Direct Spread Spectrum and Hybrid Systems that are in operation within the bands of 902-928 MHz, 2400-2483.5 MHz and 5725-5850 MHz.
- RSS-210 Issue 8: Licence-exempt Radio Apparatus (All Frequency Bands): Category I Equipment

1.2 Description of EUT

Equipment Under Test	2402-2480 MHz Portable Radio
Model	XG-25P
Power Supply	External 7.5 VDC battery
Modulation Type	FHSS
Frequency Range	2402 – 2480 MHz
Antenna Connector Type	N/A
Antenna Type	External

1.3 Test Facility

The open area test site and conducted measurement facility used to collect the radiated data is located at 360 Herndon Parkway, Suite 1400, Herndon, Virginia 20170. This site has been fully described in a report and approved by the Federal Communications Commission to perform AC line conducted and radiated emissions testing (ANSI C63.4-2003).

1.4 Related Submittal(s)/Grant(s)

This is an original certification application for Harris Corporation., Model: XG-25P UHF-L, FCC ID: OWDTR-0109-E, IC: 3636B-0109. This is a new family certification application for Industry Canada. The XG-25P UHF-L portable radio family members to be certified at this time include the following model numbers: DPXG-PFU1B and DPXG-PBU1B.

1.5 Modifications

None.

1.6 Grant Notes

RF Power switchable from 1.0 W to rated power (5.0 W).

2 Test Information

2.1 Description of Test Modes

In accordance with FCC 15.31(m), and because the EUT utilizes an operating band greater than 10 MHz, the following frequencies were tested:

Table 2-1: Channels Tested

Channel	Frequency
Low	2402
Middle	2441
High	2480

2.2 Exercising the EUT

The EUT was supplied with test software to select various transmit/receive modes (for example, high, mid, and low channel, hopping on/off, etc) for testing, and to continuously transmit during testing. The carrier was also checked to verify that information was being transmitted. There were no deviations from the test standard(s) and/or methods. The test results reported relate only to the item tested. Data is presented for as worst-case.

2.3 Test Result Summary

Table 2-2: Test Result Summary – FCC Part 15, Subpart C (Section 15.247)

Standard	Test	Pass/Fail or N/A
FCC 15.207	AC Power Conducted Emissions	N/A
FCC 15.209	Radiated Emissions	Pass
FCC 15.247(b)	Maximum Peak Power Output	Pass
FCC 15.247(d)	Antenna Conducted Spurious Emissions	Pass
FCC 15.247(d)	Band Edge Measurement	Pass
FCC 15.247(a)(1)	Carrier Frequency Separation	Pass
FCC 15.247(a)(1)(ii)	20 dB Bandwidth	Pass
FCC 15.247(a)(1)(iii)	Hopping Characteristics	Pass
FCC 15.247(a)(1)(iii)	Average Time of Occupancy	Pass

2.4 Tested System Details

The test sample was received on August 21, 2012 and May 30, 2013. Listed below are the identifiers and descriptions of all equipment, cables, and internal devices used with the EUT for this test, as applicable.

Table 2-3: Equipment Under Test (EUT)

Part	Manufacturer	Model	PN/SN	FCC ID	RTL Bar Code
XG-25P UHF-L Radio	Harris Corporation	DPXG-PFU1B (System)	14011-0030-01	OWDTR-0109-E	21045
XG-25P UHF-L Radio	Harris Corporation	DPXG-PBU1B (Scan)	14011-0030-02	OWDTR-0109-E	21046
XG-25P UHF-L Radio With external SMA connector	Harris Corporation	DPXG-PBU1B (Scan)	14011-0020-02	OWDTR-0109-E	20370

Figure 2-1: Configuration of Tested System

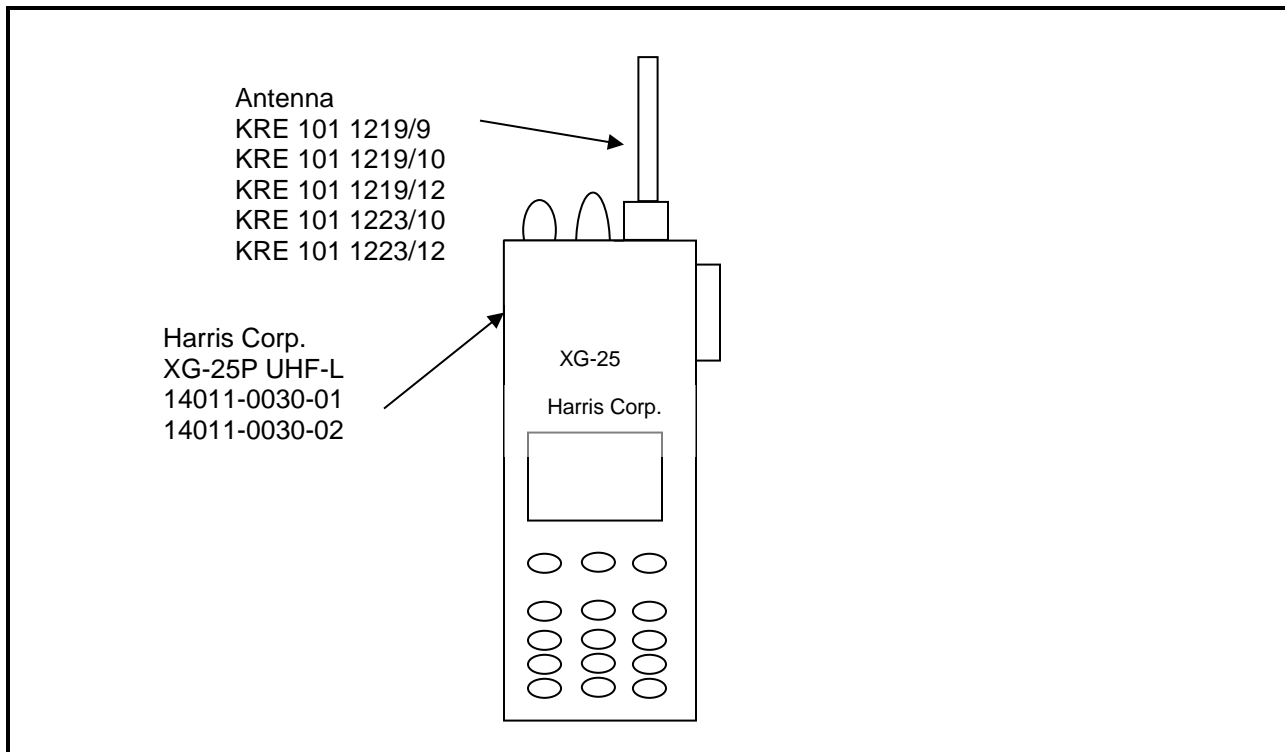

3 Peak Output Power – FCC 15.247(b)(1), RSS-210 A8.4(2), RSS-Gen 4.8

3.1 Power Output Test Procedure

Procedure: C63.10-2009 6.10

A conducted power measurement of the EUT was taken using an Rohde & Schwarz spectrum analyzer using a peak detector in a gated power measurement mode.

3.2 Power Output Test Data

Table 3-1: Power Output Test Data – High Power

Frequency (MHz)	Peak Conducted Power (SDR) (dBm)	Peak Conducted Power (EDR) (dBm)
2402	3.6	3.4
2441	3.8	3.2
2480	3.8	2.7

Table 3-2: Power Output Test Equipment

RTL Asset #	Manufacturer	Model	Part Type	Serial Number	Calibration Due Date
901581	Rohde & Schwarz	1166.1660.50	Spectrum Analyzer	2001006	6/3/13

Test Personnel:

Daniel W. Baltzell
 EMC Test Engineer



Signature

October 2, 2012
 Date of Tests

4 Antenna Conducted Spurious Emissions – FCC 15.247(d), RSS-210 A8.5

Procedure: C63.10-2009 6.7

Low, middle and high channels and hopping mode were investigated.

Plot 4-1: Antenna Conducted Spurious TX Frequency - 2402 MHz

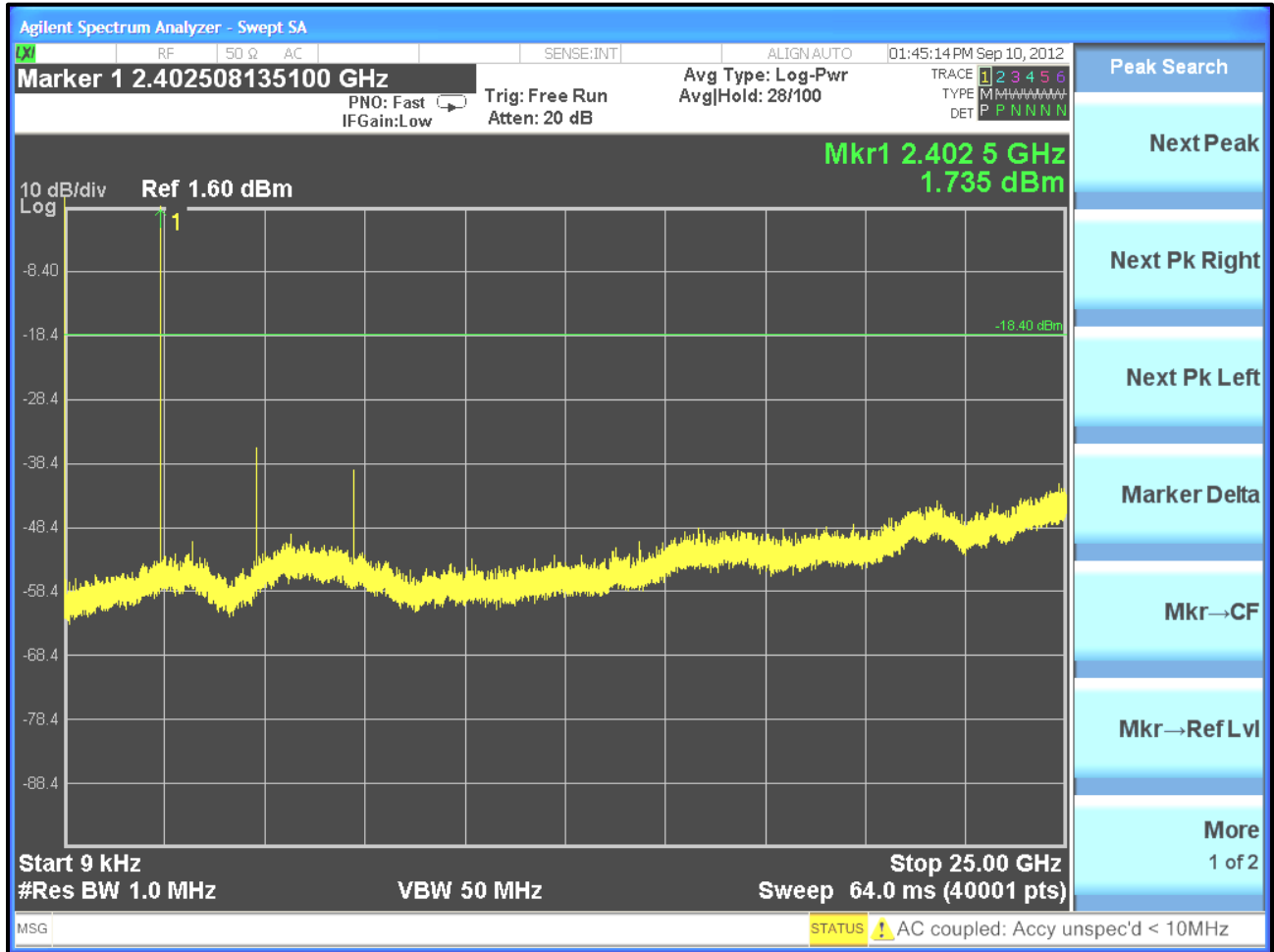

Plot 4-2: Antenna Conducted Spurious TX Frequency - 2441 MHz

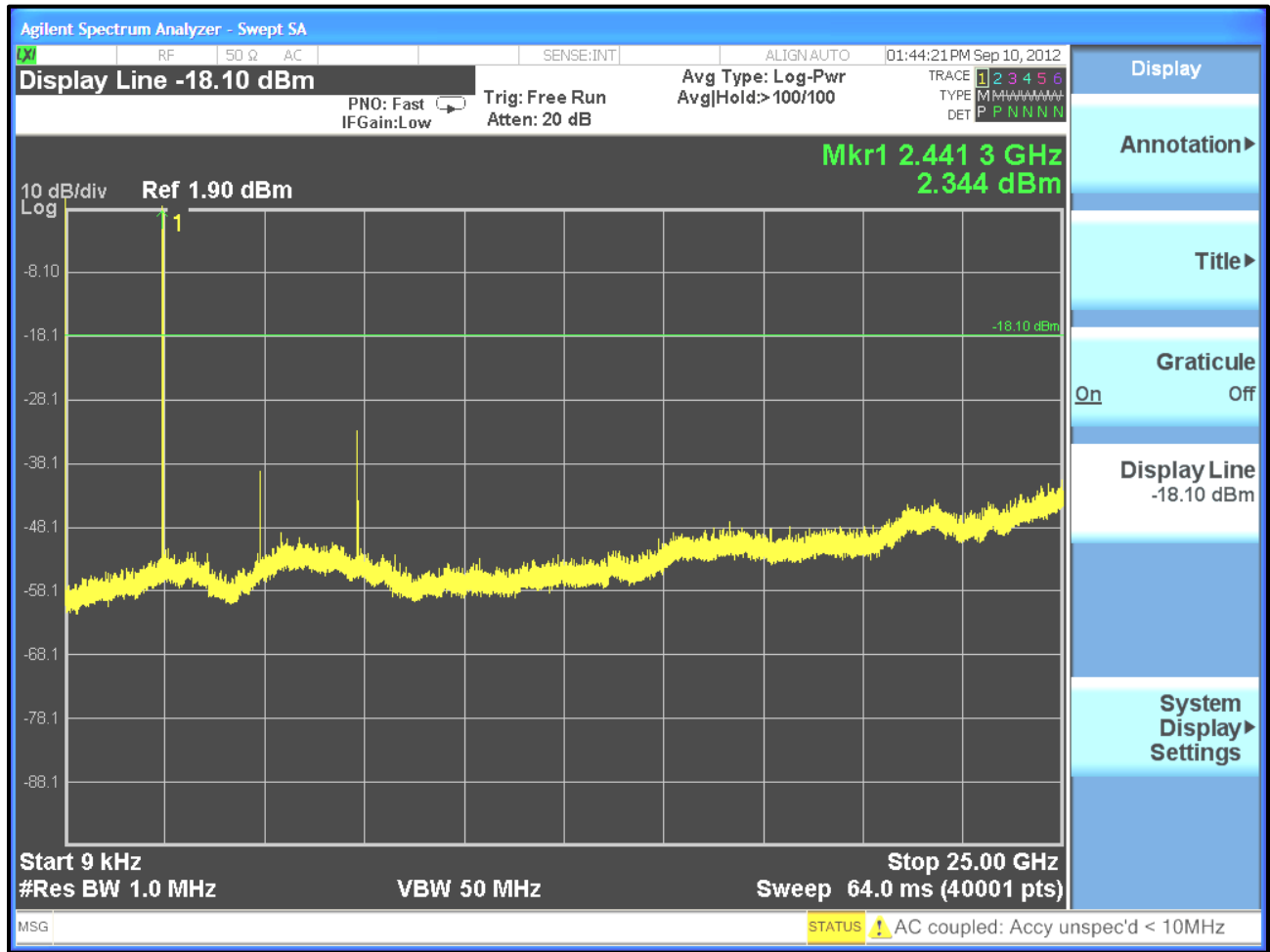

Plot 4-3: Antenna Conducted Spurious TX Frequency - 2480 MHz

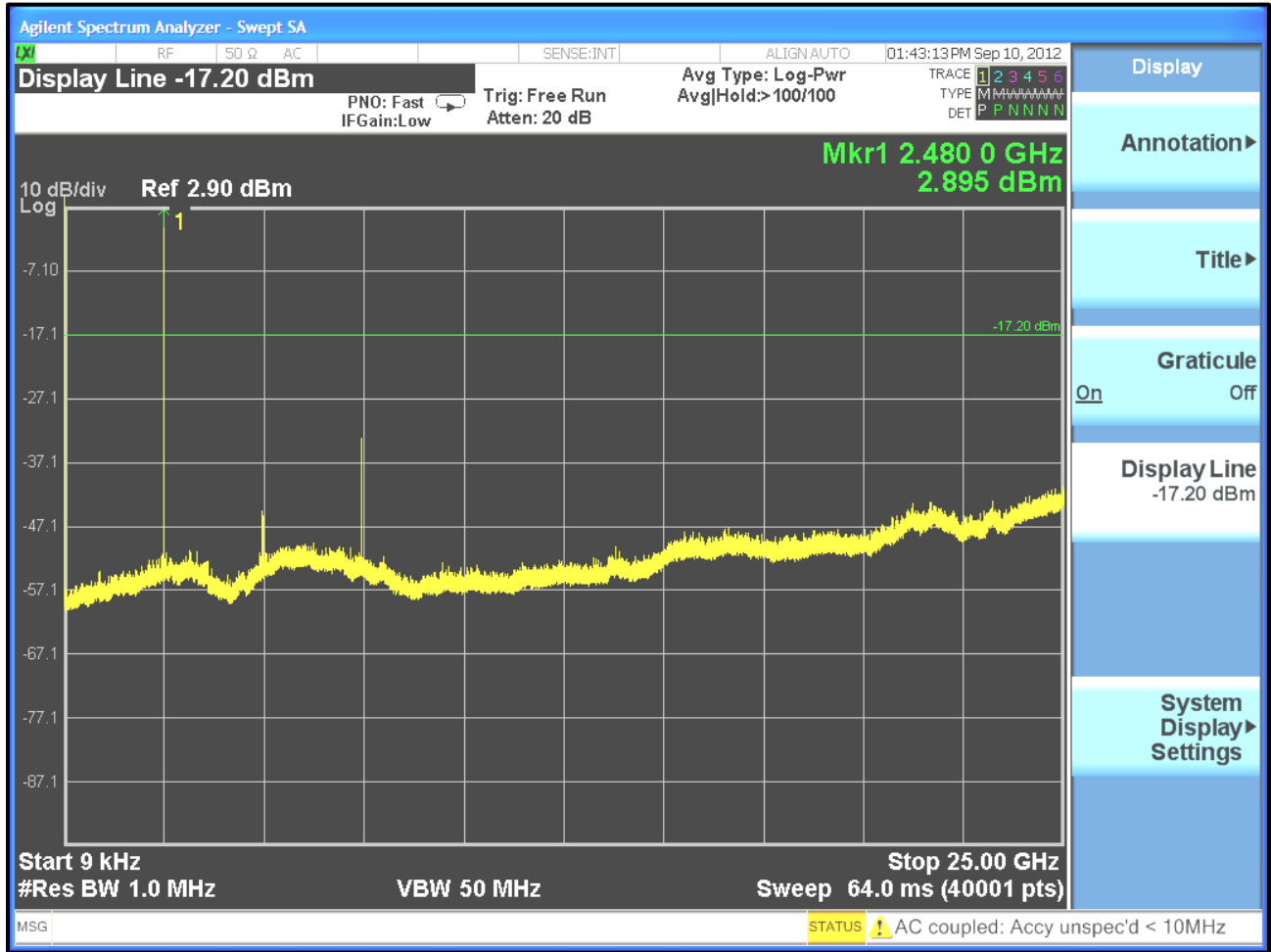

Plot 4-4: Antenna Conducted Spurious - Hopping Mode

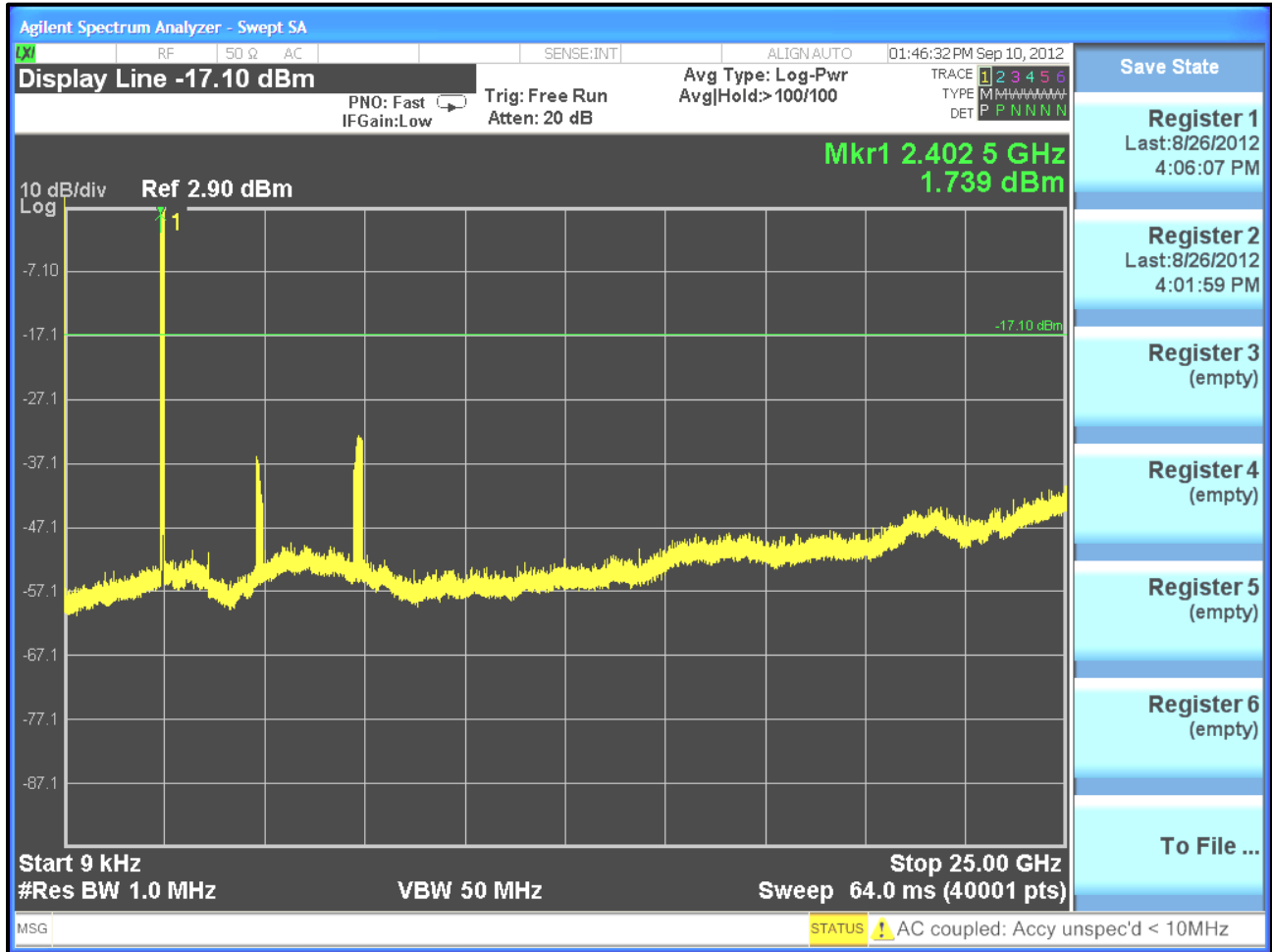

Table 4-1: Antenna Conducted Spurious Test Equipment

RTL Asset #	Manufacturer	Model	Part Type	Serial Number	Calibration Due Date
901583	Agilent Technologies	N9010A	EXA Signal Analyzer (10 Hz - 26.5 GHz)	MY51250846	3/13/13

Test Personnel:

Daniel W. Baltzell EMC Test Engineer	 Signature	September 10, 2012 Date of Tests
---	--	-------------------------------------

5 Band-Edge Compliance of RF Conducted Emissions – FCC 15.247(d), RSS-210 A8.5

5.1 Band Edge Test Procedure

Procedure: C63.10-2009 6.9.2.4

The EUT was connected to the spectrum analyzer through suitable attenuation. The span was set wide enough to capture the peak level of the emission operating on the channel closest to the band edge, as well as any modulation products which fall outside of the authorized band of operation. The spectrum analyzer was set to the following:

RBW > = 1 MHz
VBW > = 3 MHz
Sweep = auto
Detector function = peak
Trace = max hold

The trace was allowed to stabilize. The marker was set on the emission at the band edge. The marker-delta was used to show the delta between the maximum in-band emission and the emission at the band edge, and was compared to the 20 dBc requirement of 15.247(d) (when using peak emissions). This measurement was taken in both fixed frequency and hopping modes.

5.2 Test Results

Plot 5-1: Lower Band Edge TX Frequency - 2402 MHz

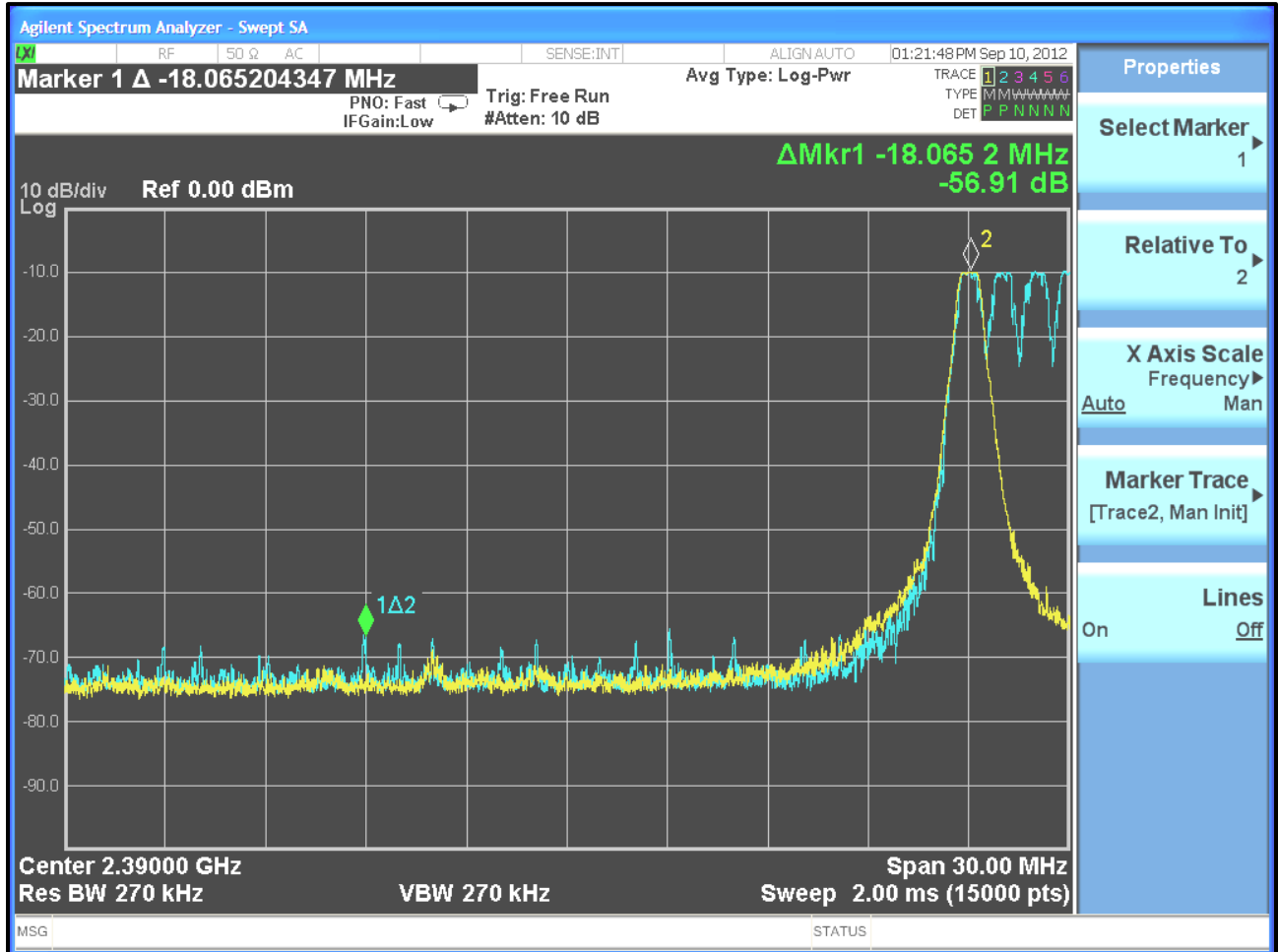

Plot 5-2: Upper Band Edge TX Frequency - 2480 MHz

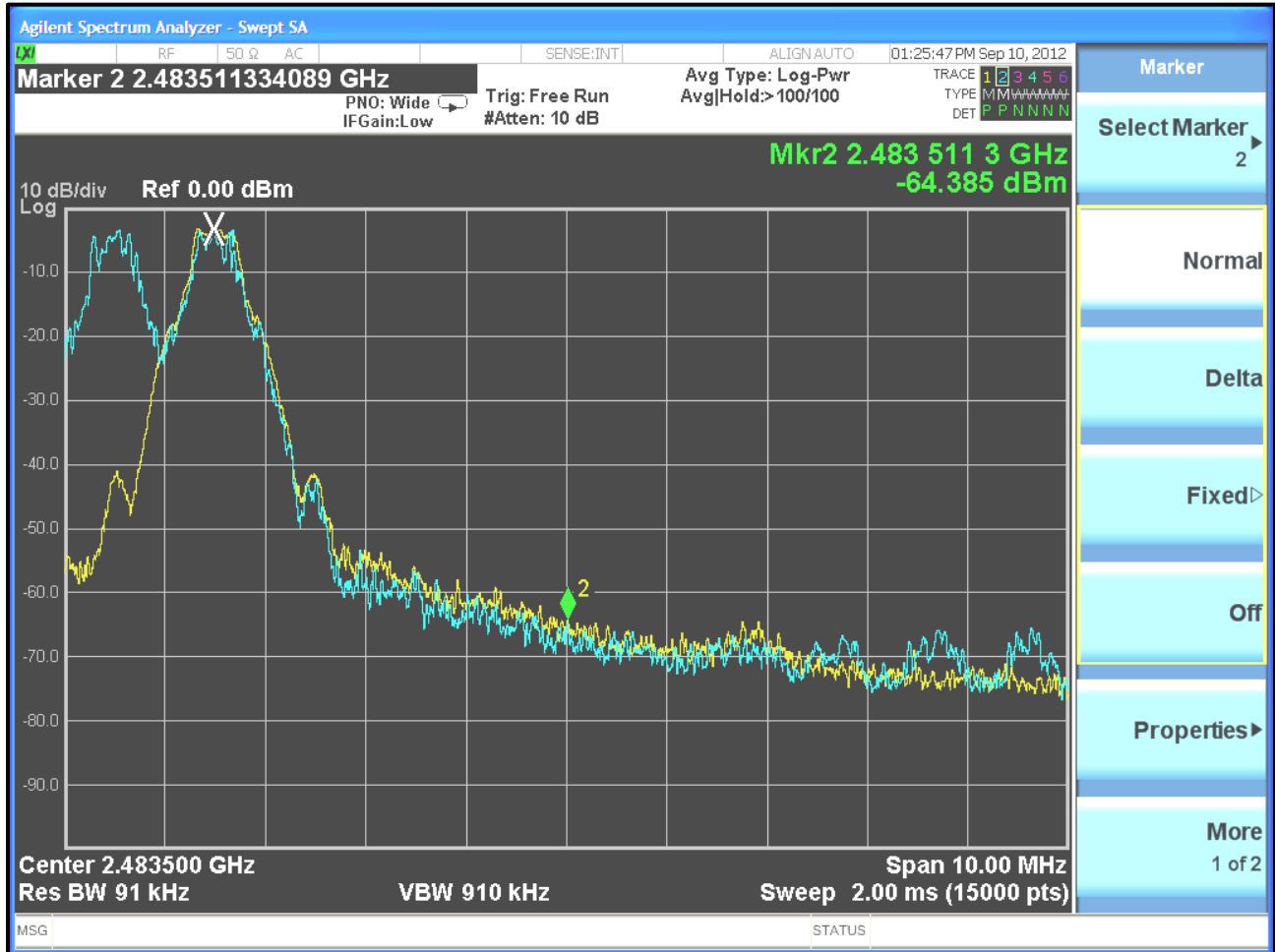

Table 5-1: Band-Edge Compliance of RF Conducted Emissions Test Equipment

RTL Asset #	Manufacturer	Model	Part Type	Serial Number	Calibration Due Date
901413	Agilent Technologies	E4448A	Spectrum Analyzer	US44020346	12/29/12

Test Personnel:

Daniel W. Baltzell
 EMC Test Engineer

Signature

September 10, 2012
 Date of Tests

5.3 Radiated Band Edge Emissions

Table 5-2: Radiated Band Edge Emissions Test Data

Frequency (MHz)	Peak Spectrum Analyzer Level (1 MHz RBW/ VBW) (dBuV)	Average Analyzer Detector (1 MHz RBW/ 10 Hz VBW) (dBuV)	Site Correction Factor (dB/m)	Corrected Average Level (dBuV/m)	Delta Measurement From Plots (dB)	Average Limit (dBuV/m)	Margin (dB)
2402.000	80.6	68.9	22.1	91.0	56.9	54.0	-19.9
2480.000	80.8	69.6	22.3	91.9	64.4	54.0	-26.5

Table 5-3: Radiated Band Edge Test Equipment

RTL Asset #	Manufacturer	Model	Part Type	Serial Number	Calibration Due Date
901594	Insulated Wire Inc.	KPS-1503-360-KPR	SMK RF Cables 36"	NA	8/16/13
901581	Rohde & Schwarz	1166.1660.50	Spectrum Analyzer	2001006	6/3/13
900772	EMCO	3161-02	Horn Antenna (2 - 4 GHz)	9804-1044	4/19/14
900886	EMI Shop	WRT000-0003	Turntable OATS	N/A	Not Required
900878	Rhein Tech Laboratories	AM3-1197-0005	3 meter antenna mast, polarizing	OATS1	N/A

Test Personnel:

Daniel W. Baltzell
 EMC Test Engineer

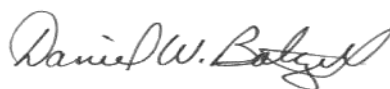

Signature

September 10, 2012
 Date of Test

6 20 dB Bandwidth – FCC 15.247(a)(1), RSS-210 A8.1(a)

6.1 20 dB Bandwidth Test Procedure

Procedure: C63.10-2009 6.9

6.2 20 dB Modulated Bandwidth Test Data

Table 6-1: 20 dB Modulated Bandwidth Test Data (SDR)

Frequency (MHz)	20 dB Bandwidth (MHz)
2402	1.01
2441	1.04
2480	0.99

Table 6-2: 20 dB Modulated Bandwidth Test Data (EDR)

Frequency (MHz)	20 dB Bandwidth (MHz)
2402	1.33
2441	1.28
2480	1.23

6.3 20 dB Bandwidth Plots

Plot 6-1: 20 dB Bandwidth - 2402 MHz (SDR)

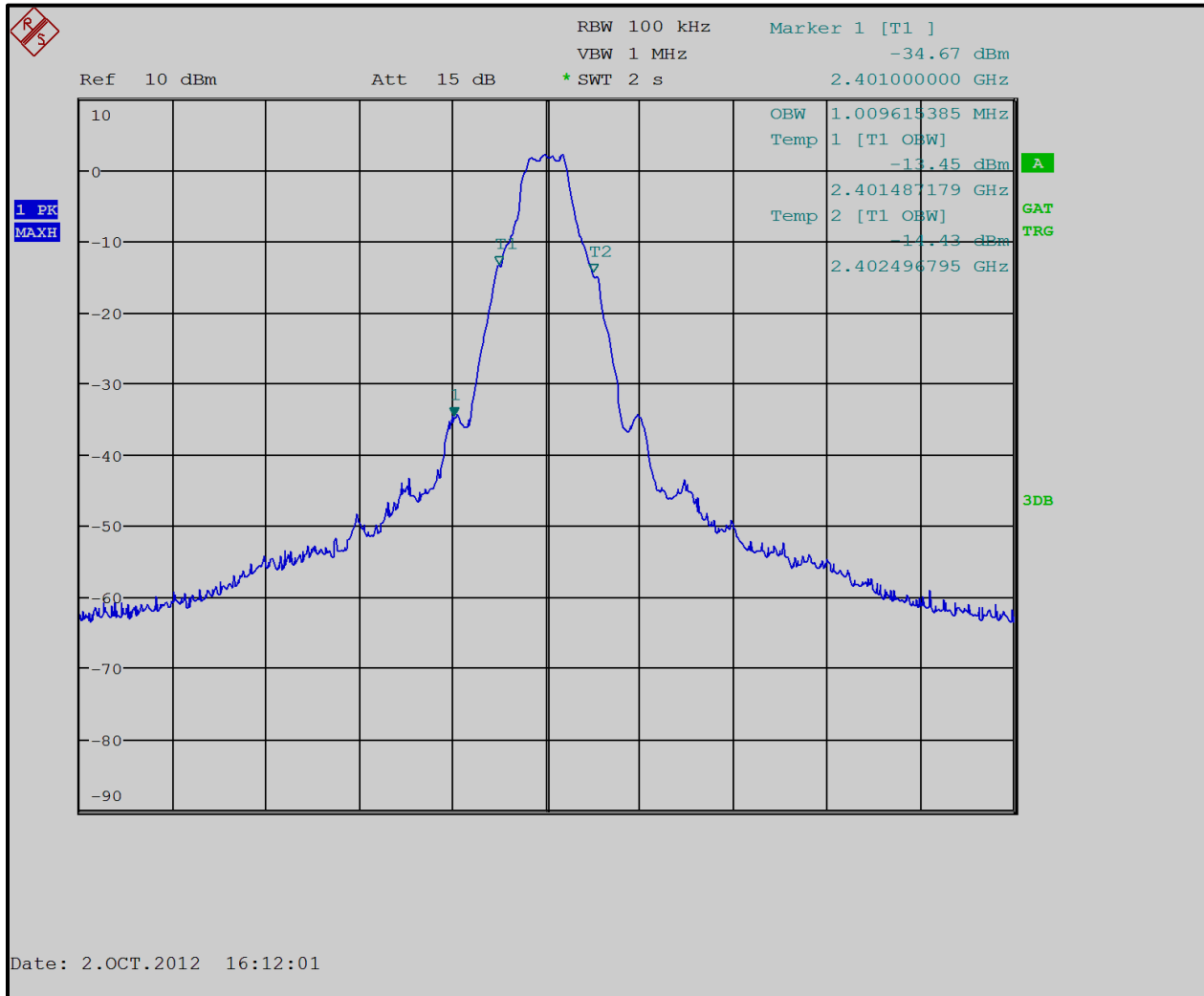

Plot 6-2: 20 dB Bandwidth - 2441 MHz (SDR)

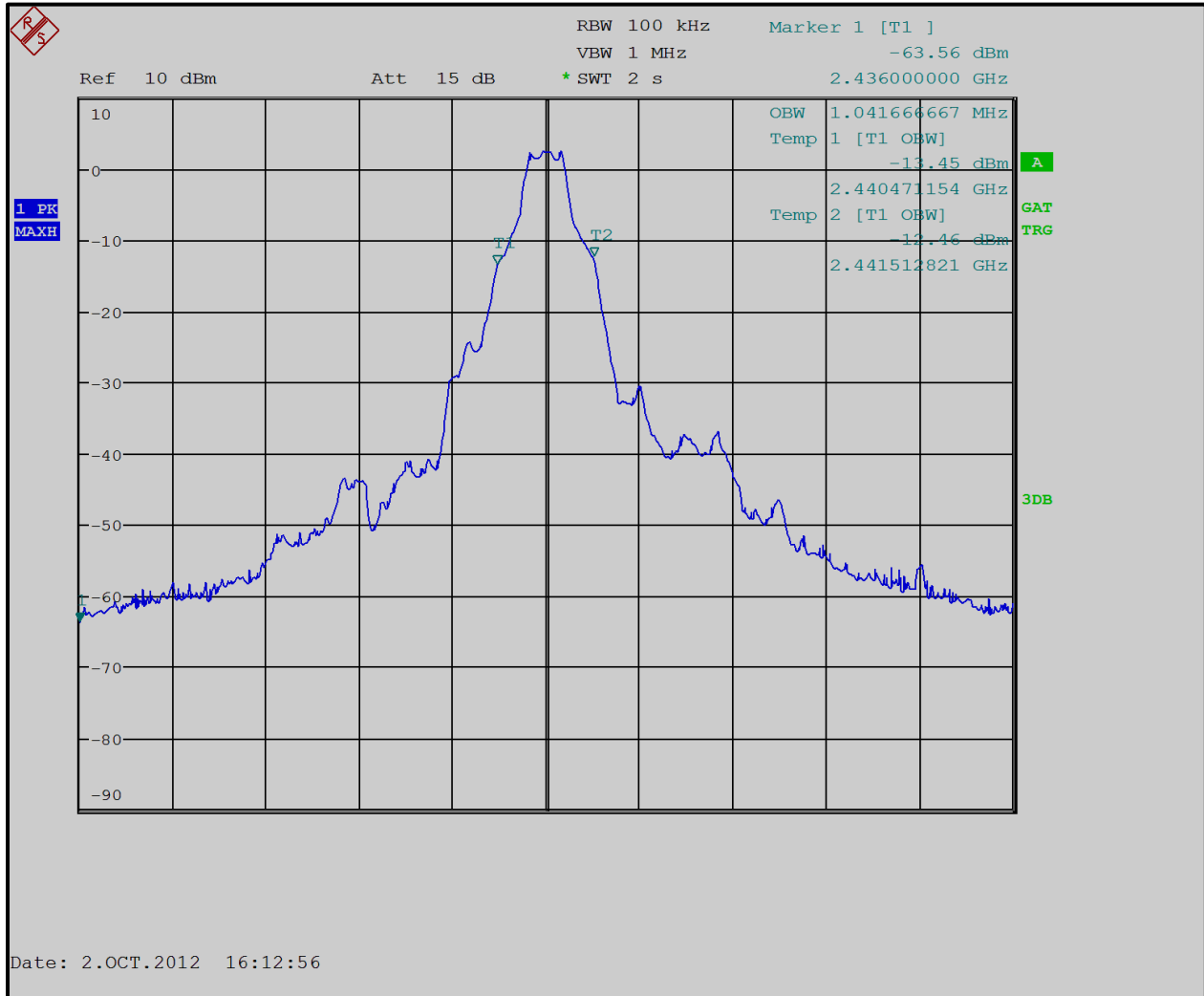

Plot 6-3: 20 dB Bandwidth - 2480 MHz (SDR)

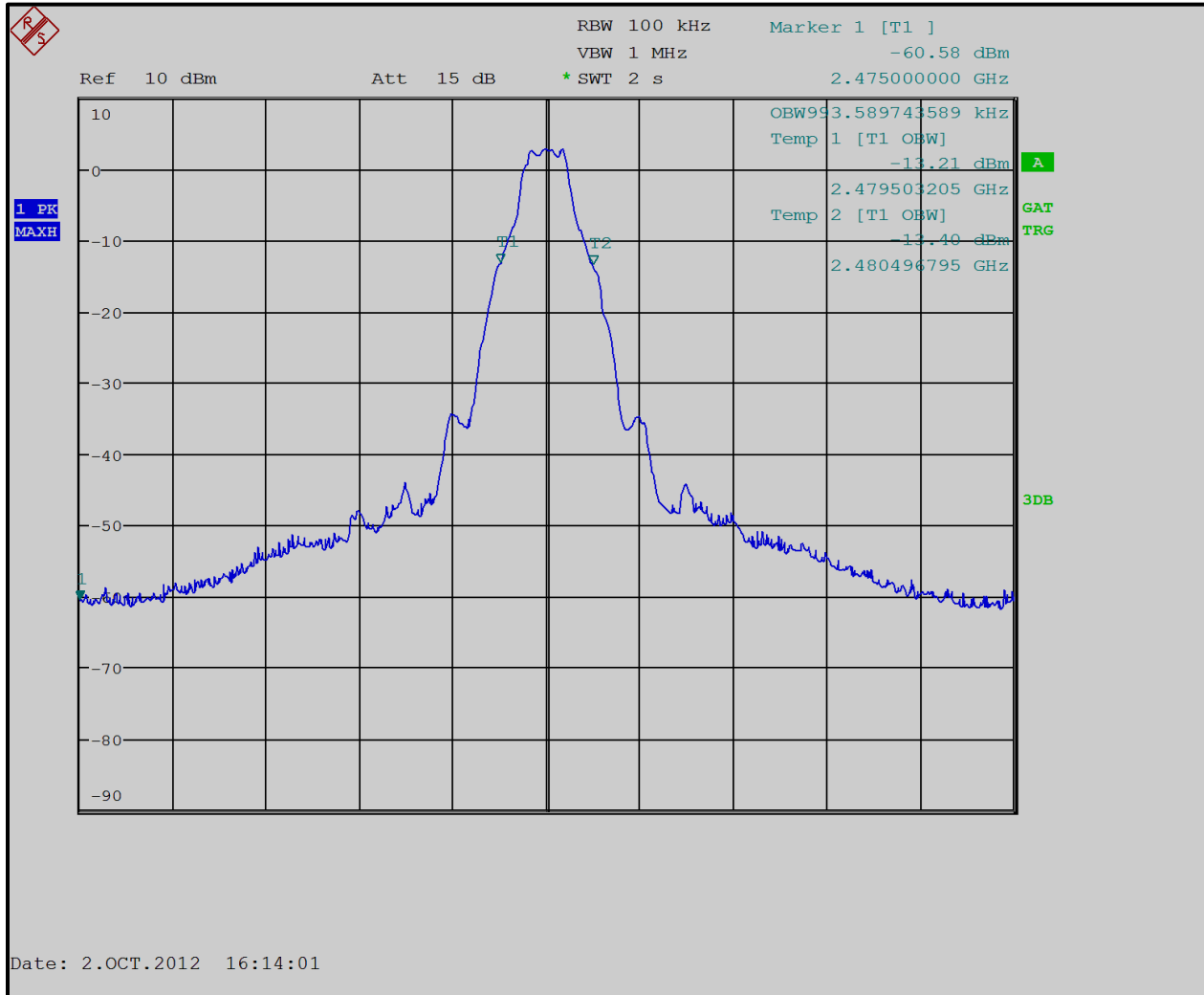

Plot 6-4: 20 dB Bandwidth - 2402 MHz (EDR)

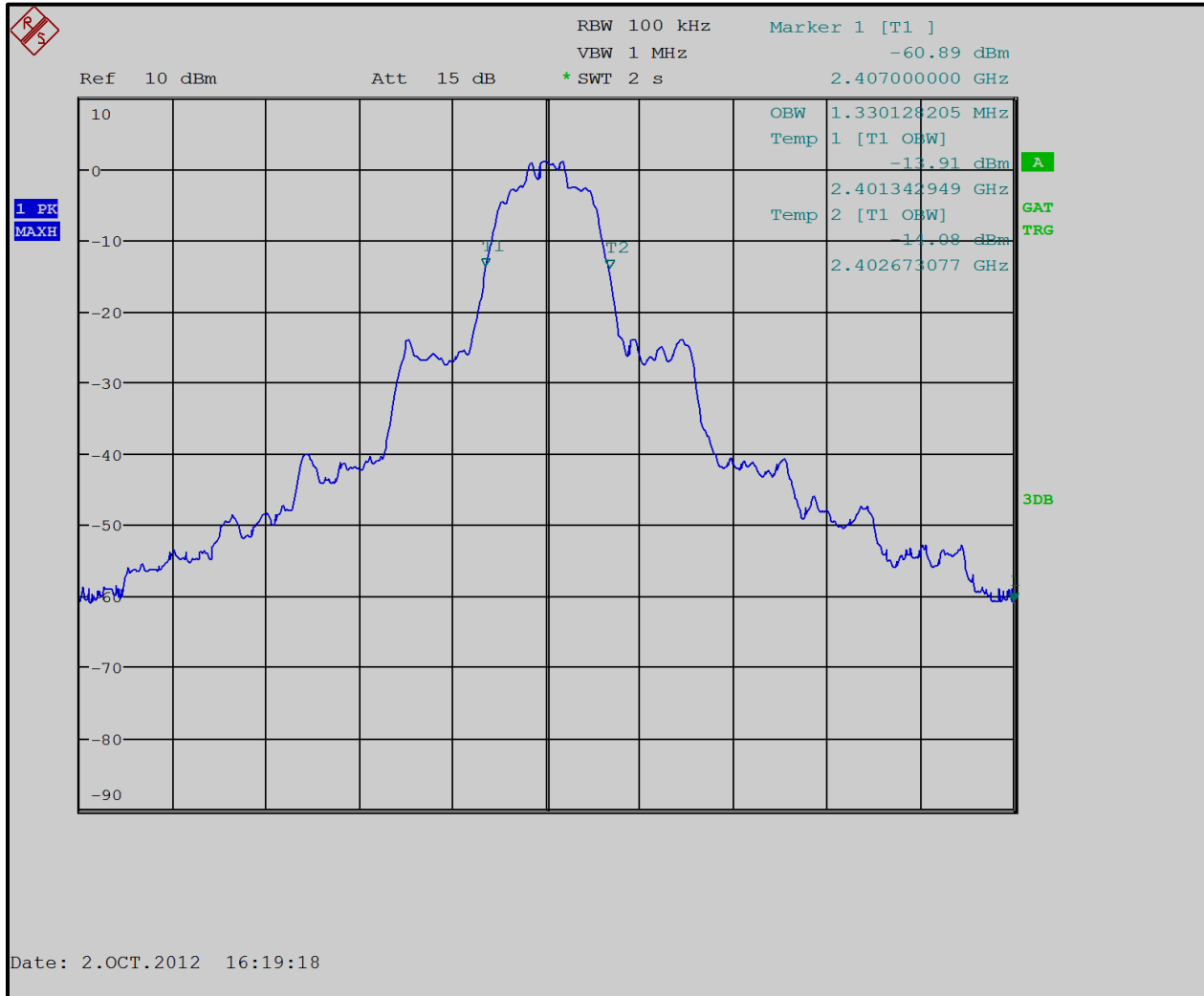

Plot 6-5: 20 dB Bandwidth - 2441 MHz (EDR)

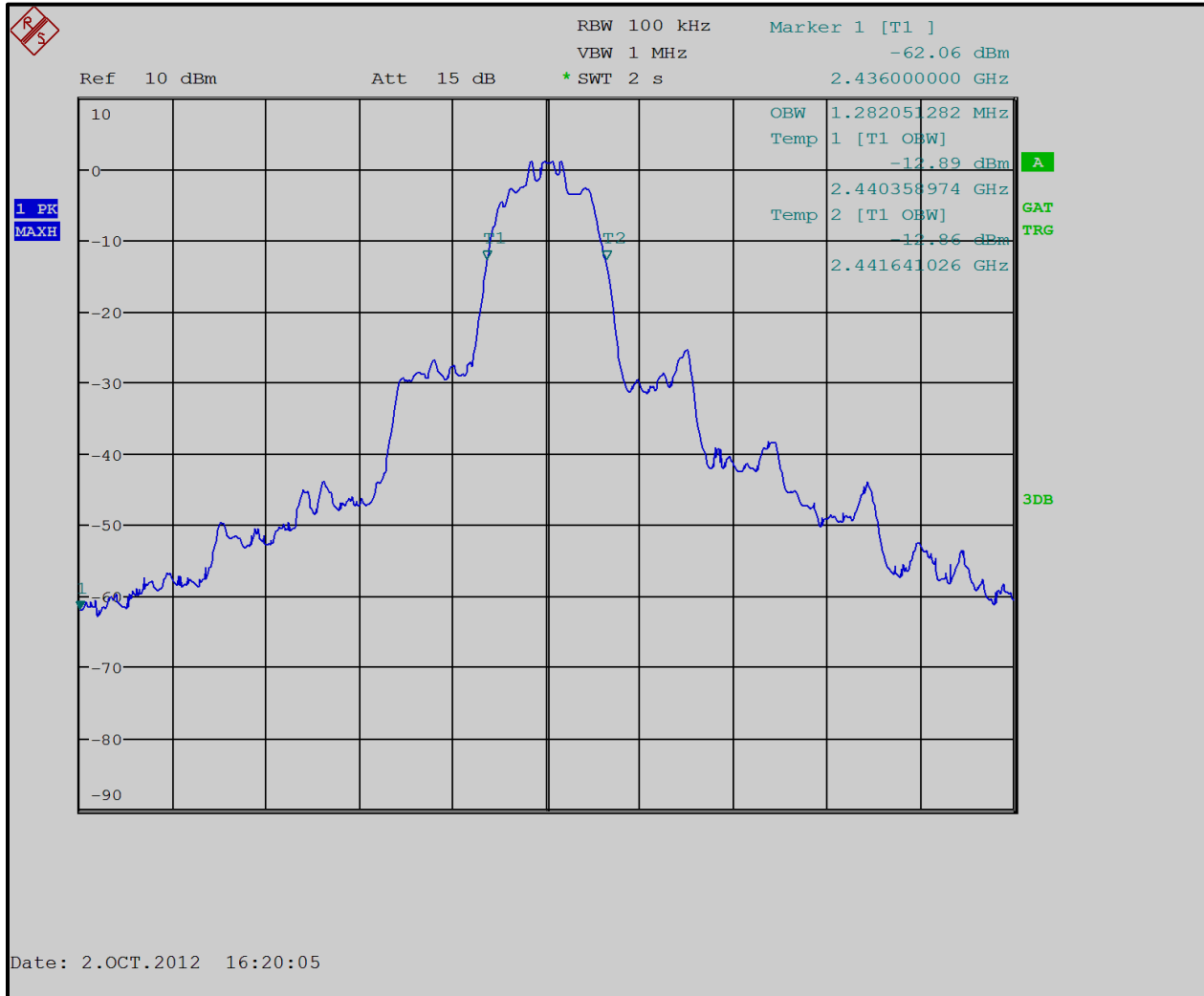

Plot 6-6: 20 dB Bandwidth - 2480 MHz (EDR)

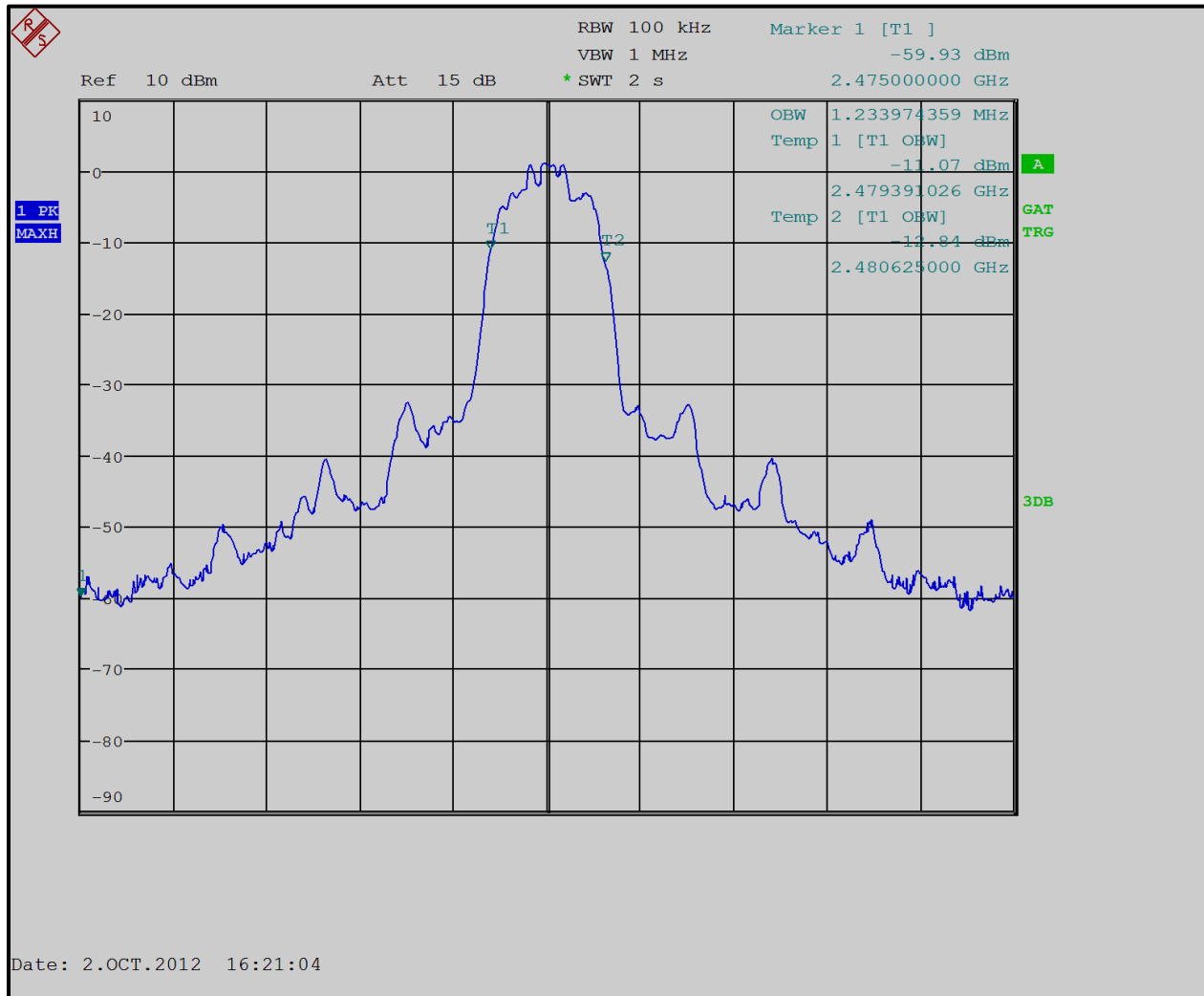

Table 6-3: 20 dB Bandwidth Test Equipment

RTL Asset #	Manufacturer	Model	Part Type	Serial Number	Calibration Due Date
901581	Rohde & Schwarz	1166.1660.50	Spectrum Analyzer	2001006	6/3/13

Test Personnel:

<p>Daniel W. Baltzell EMC Test Engineer</p>	 Signature	<p>October 2, 2012 Date of Tests</p>
--	--	---

7 Carrier Frequency Separation - 15.247(a)(1), RSS-210 A8.1(b)

7.1 Carrier Frequency Separation Test Procedure

Procedure: C63.10-2009 7.7.2

Frequency hopping systems shall have hopping channel carrier frequencies separated by a minimum of 25 kHz, or the 20 dB bandwidth of the hopping channel, whichever is greater.

Measured frequency separation = 1.0 MHz

7.2 Carrier Frequency Separation Test Data

Plot 7-1: Carrier Frequency Separation

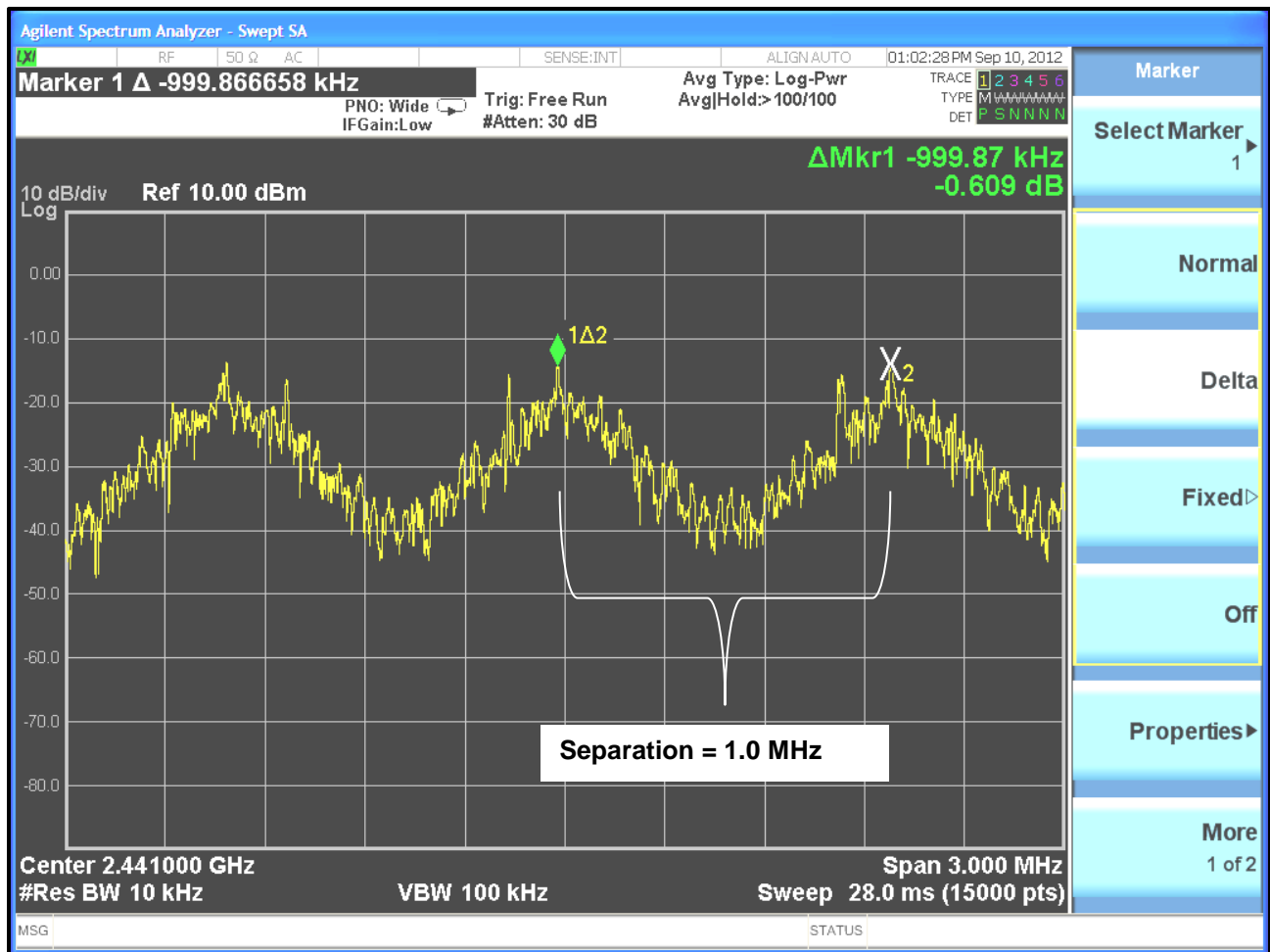

8 Hopping Characteristics – FCC 15.247(a)(1)(iii), RSS-210 A8.1(d)

8.1 Hopping Characteristics Test Procedure

Procedure: C63.10-2009 7.7.3

Frequency hopping systems in the 2400–2483.5 MHz band shall use at least 15 channels. The average time of occupancy on any channel shall not be greater than 0.4 seconds within a period of 0.4 seconds multiplied by the number of hopping channels employed. Frequency hopping systems may avoid or suppress transmissions on a particular hopping frequency provided that a minimum of 15 channels are used.

8.2 Number of Hopping Frequencies

Measured number of hopping frequencies = 79

Plot 8-1: Number of Hopping Frequencies (2402 - 2480 MHz)

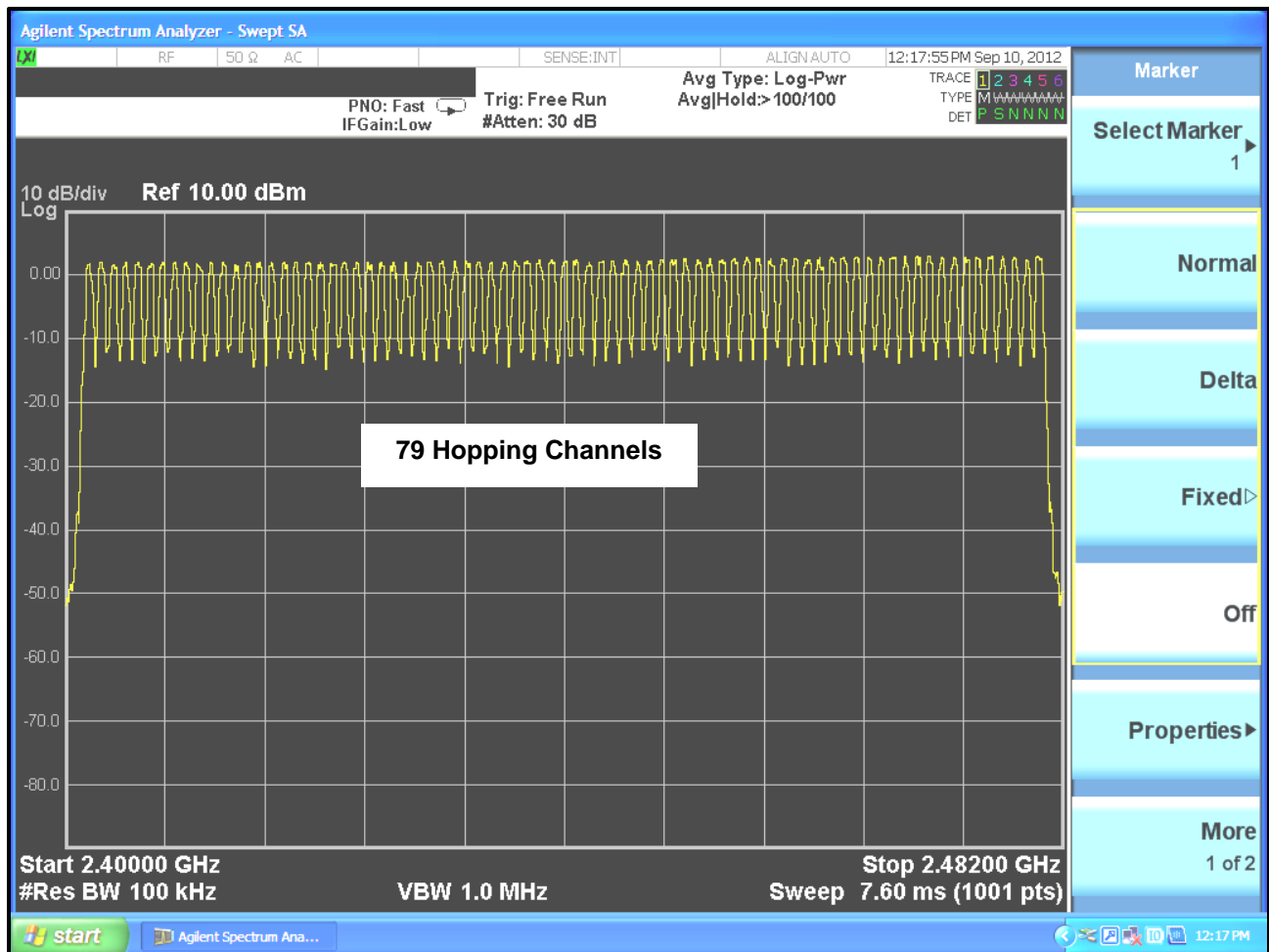

8.3 Average Time of Occupancy

Procedure: C63.10-2009 7.7.4

The average time of occupancy on any channel shall not be greater than 0.4 seconds within a period of 0.4 seconds multiplied by the number of hopping channels employed.

Allowed period = 0.4 s X 79 channels = 31.6 s

Pulse width = 0.414 ms

Number of pulses within a 31.6 s sweep = 32 x 10 = 320

Average time of occupancy in 31.6 s = 0.414 ms X 320 pulses = 0.133 s, which meets the limit of 0.4 s

Plot 8-2: Time of Occupancy (Dwell Time)

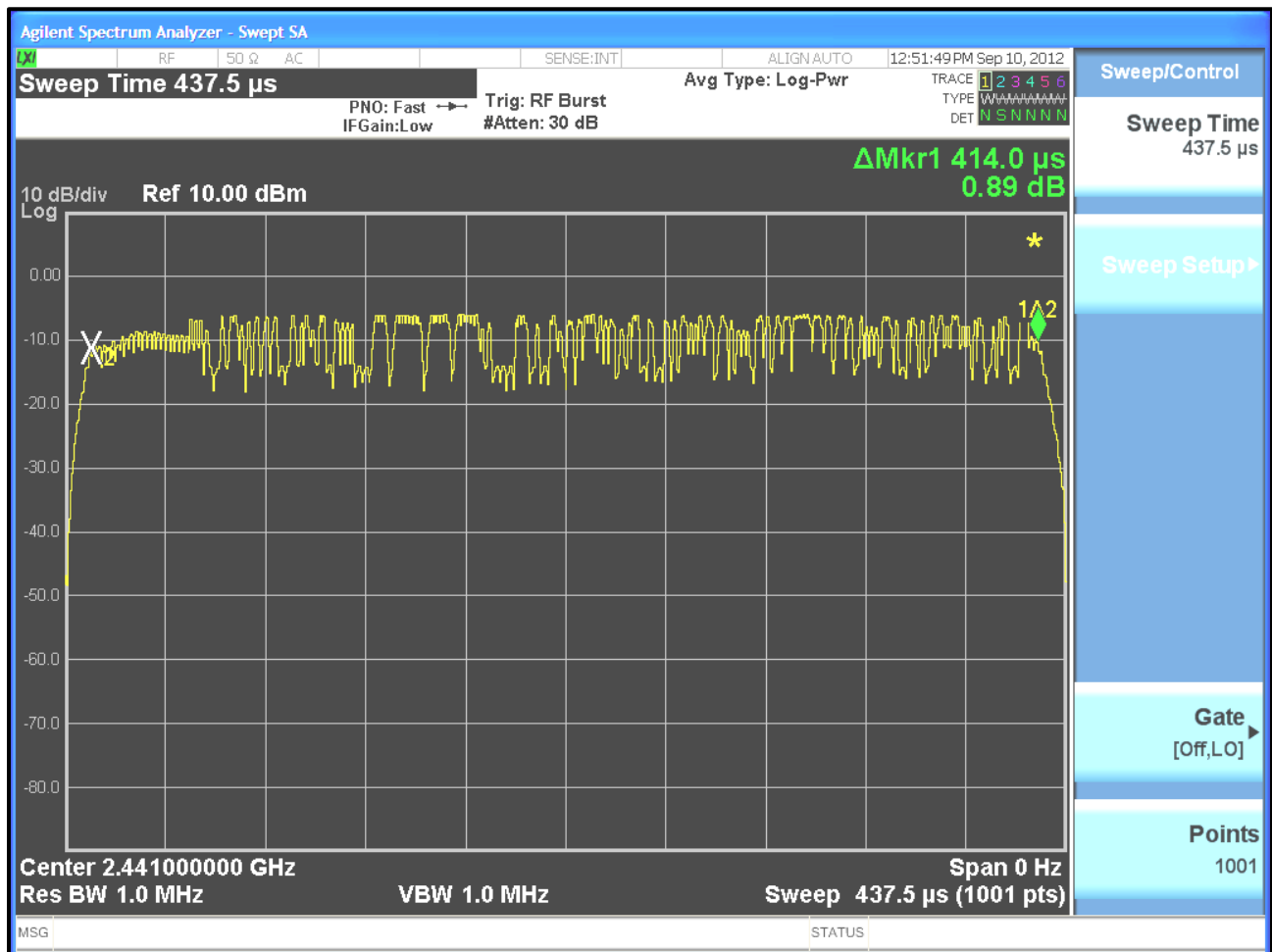

Plot 8-3: Number of Pulses in 3.16 Second Sweep

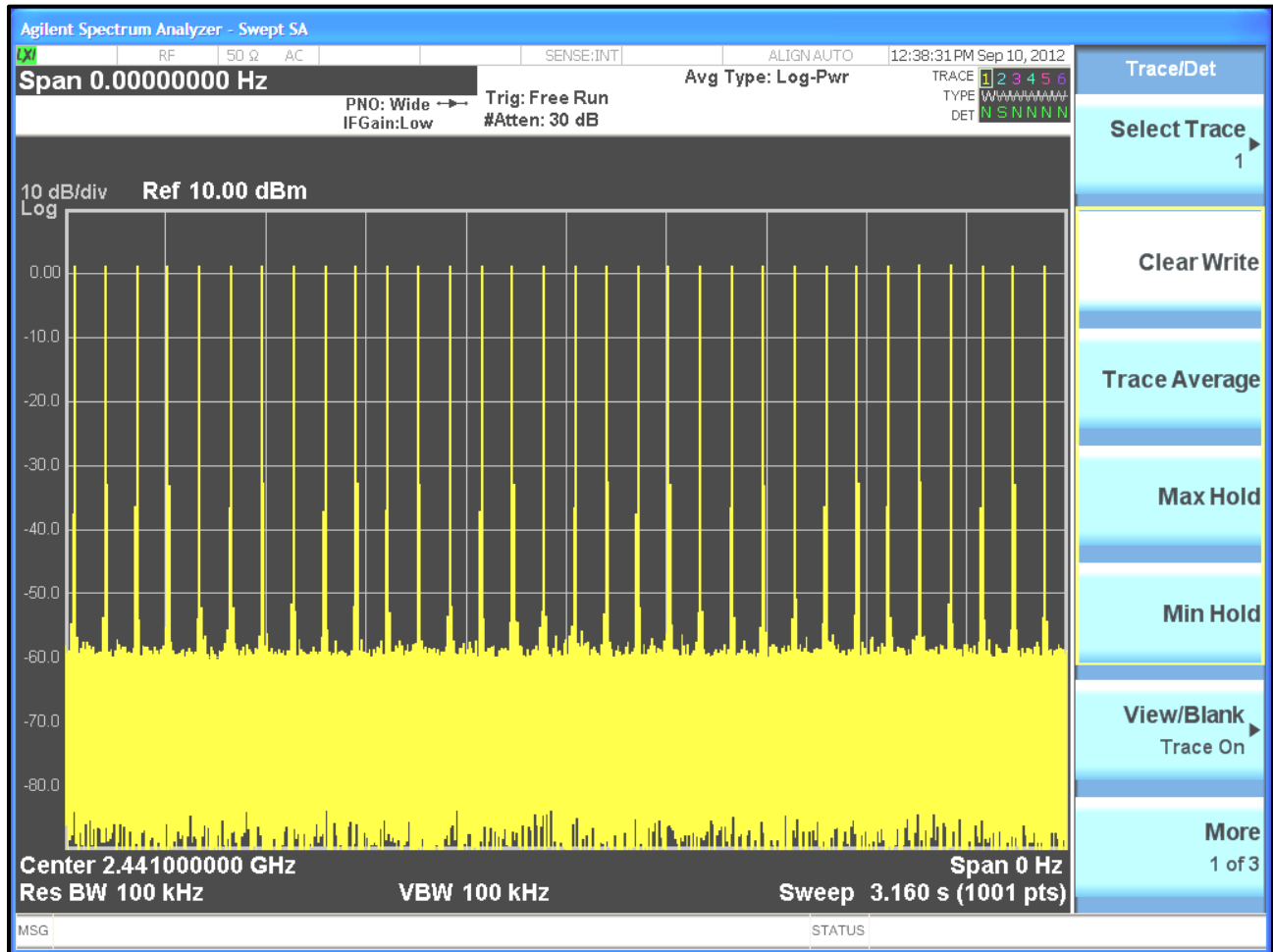

Duty cycle: $20 * \log(TX\ On/TX\ ON+TX\ OFF) = 20\log(.414/((3.16s/32)*1000))=-47.6dB$

Table 8-1: Hopping Characteristics Test Equipment

RTL Asset #	Manufacturer	Model	Part Type	Serial Number	Calibration Due Date
901583	Agilent Technologies	N9010A	EXA Signal Analyzer (10 Hz-26.5 GHz)	MY51250846	3/13/13

Test Personnel:

Daniel W. Baltzell
 EMC Test Engineer

Signature

September 10, 2012
 Date of Tests

9 Radiated Emissions Test Results - FCC Rules and Regulations Part 15.247(d)

9.1 Limits of Radiated Emissions Measurement

Frequency (MHz)	Field Strength (uV/m)	Measurement Distance (m)
0.009-0.490	2400/f (kHz)	300
0.490-1.705	2400/f (kHz)	30
1.705-30.0	30	30
30-88	100	3
88-216	150	3
216-960	200	3
Above 960	500	3

As shown in 15.35(b), for frequencies above 1000 MHz, the field strength limits are based on average detector, however, the peak field strength of any emission shall not exceed the maximum permitted average limits, specified above by more than 20 dB under any circumstances of modulation.

9.2 Radiated Emissions Measurement Test Procedure

Before final measurements of radiated emissions were made on the open-field three/ten meter range, the EUT was scanned indoors at one and three meter distances. This was done in order to determine its emissions spectrum signature. The physical arrangement of the test system and associated cabling was varied in order to determine the effect on the EUT's emissions in amplitude, direction and frequency. This process was repeated during final radiated emissions measurements on the open-field range, at each frequency, in order to ensure that maximum emission amplitudes were attained.

Final radiated emissions measurements were made on the three/ten-meter, open-field test site. The EUT was placed on a nonconductive turntable 0.8 meters above the ground plane. The spectrum was examined from 9 kHz to the 10th harmonic of the highest fundamental transmitter frequency (24.8 GHz).

At each frequency, the EUT was rotated 360°, and the antenna was raised and lowered from 1 to 4 meters in order to determine the emission's maximum level. Measurements were taken using both horizontal and vertical antenna polarizations. For frequencies between 30 and 1000 MHz, the spectrum analyzer's 6 dB bandwidth was set to 120 kHz, and the analyzer was operated in the CISPR quasi-peak detection mode. For emissions above 1000 MHz, emissions are measured using the average detector function with a minimum resolution bandwidth of 1 MHz. No video filter less than 10 times the resolution bandwidth was used. The highest emission amplitudes relative to the appropriate limit were measured and recorded in this report.

9.2.1 Radiated Emissions Harmonics/Spurious Test Data

Table 9-1: Radiated Emissions Harmonics/Spurious - 2402 MHz

Emission Frequency (MHz)	Average Detector Level (dBuV) (1 MHz RBW/VBW)	Site Correction Factor (dB/m)	Duty Cycle (-47.6 dB) Average Emission Level (dBuV/m)	Average Limit (dBuV/m)	Average Margin (dB)
4804.000	53.3	-1.1	4.6	54.0	-49.4
12010.000	40.7	9.8	2.9	54.0	-51.1
19216.000	42.3	20.6	15.3	54.0	-38.7

Emission Frequency (MHz)	Peak Detector Level (dBuV) (1 MHz RBW/VBW)	Site Correction Factor (dB/m)	Peak Emission Level (dBuV/m)	Peak Limit (dBuV/m)	Peak Margin (dB)
4804.000	53.8	-1.1	52.7	74.0	-21.3
12010.000	43.3	9.8	53.1	74.0	-20.9
19216.000	44.6	20.6	65.2	74.0	-8.8

Table 9-2: Radiated Emissions Harmonics/Spurious - 2441 MHz

Emission Frequency (MHz)	Average Detector Level (dBuV) (1 MHz RBW/VBW)	Site Correction Factor (dB/m)	Duty Cycle (-47.6 dB) Average Emission Level (dBuV/m)	Average Limit (dBuV/m)	Average Margin (dB)
4882.000	50.5	-1.0	1.9	54.0	-52.1
7323.000	55.9	0.9	9.2	54.0	-44.8
12205.000	41.5	11.2	5.1	54.0	-48.9
19528.000	42.6	20.2	15.2	54.0	-38.8

Emission Frequency (MHz)	Peak Detector Level (dBuV) (1 MHz RBW/VBW)	Site Correction Factor (dB/m)	Peak Emission Level (dBuV/m)	Peak Limit (dBuV/m)	Peak Margin (dB)
4882.000	51.2	-1.0	50.2	74.0	-23.8
7323.000	56.3	0.9	57.2	74.0	-16.8
12205.000	43.9	11.2	55.1	74.0	-18.9
19528.000	44.5	20.2	64.7	74.0	-9.3

Table 9-3: Radiated Emissions Harmonics/Spurious - 2480 MHz

Emission Frequency (MHz)	Average Detector Level (dBuV) (1 MHz RBW/VBW)	Site Correction Factor (dB/m)	Duty Cycle (-47.6 dB) Average Emission Level (dBuV/m)	Average Limit (dBuV/m)	Average Margin (dB)
4960.000	50.9	-1.0	2.3	54.0	-51.7
7440.000	53.8	1.1	7.3	54.0	-46.7
12400.000	40.7	12.6	5.7	54.0	-48.3
19840.000	42.3	20.6	15.3	54.0	-38.7
22320.000	42.0	21.8	16.2	54.0	-37.8
24800.000	43.5	22.4	18.3	54.0	-35.7

Emission Frequency (MHz)	Peak Detector Level (dBuV) (1 MHz RBW/VBW)	Site Correction Factor (dB/m)	Peak Emission Level (dBuV/m)	Peak Limit (dBuV/m)	Peak Margin (dB)
4960.000	51.7	-1.0	50.7	74.0	-23.3
7440.000	54.3	1.1	55.4	74.0	-18.6
12400.000	44.1	12.6	56.7	74.0	-17.3
19840.000	43.4	20.6	64.0	74.0	-10.0
22320.000	44.3	21.8	66.1	74.0	-7.9
24800.000	44.9	22.4	67.3	74.0	-6.7

Table 9-4: Radiated Emissions Harmonics/Spurious – Hopping Mode

Emission Frequency (MHz)	Peak Detector Level (dBuV) (1 MHz RBW/VBW)	Average Detector Level (dBuV) (1 MHz RBW/VBW)	Site Correction Factor (dB/m)	Duty Cycle (-47.6 dB) Corrected Average Emission Level (dBuV/m)	Average Limit (dBuV/m)	Average Margin (dB)
4803.630	52.1	49.3	-1.1	0.6	54.0	-53.4
4816.170	51.0	49.4	-1.1	0.7	54.0	-53.3
4820.295	50.8	48.3	-1.1	-0.4	54.0	-54.4
4824.090	50.5	48.9	-1.1	0.2	54.0	-53.8
4826.000	50.8	50.6	-1.0	2.0	54.0	-52.0
4929.690	49.6	47.3	-1.0	-1.3	54.0	-55.3
7262.540	55.4	52.9	0.9	6.2	54.0	-47.8
7263.490	55.3	52.9	0.9	6.2	54.0	-47.8
7272.040	54.5	52.0	0.9	5.3	54.0	-48.7
7320.110	53.9	53.3	1.0	6.7	54.0	-47.3
7350.130	52.3	50.3	1.0	3.7	54.0	-50.3

Table 9-5: Radiated Emissions Test Equipment

RTL Asset #	Manufacturer	Model	Part Type	Serial Number	Calibration Due Date
900151	Rohde and Schwarz	HFH2-Z2	Loop Antenna (9 kHz - 30 MHz)	827525/019	10/1/13
900932	Hewlett Packard	8449B OPT H02	Preamplifier (1 - 26.5 GHz)	3008A00505	8/10/13
900878	Rhein Tech Laboratories	AM3-1197-0005	3 meter antenna mast, polarizing	OATS1	N/A
901592	Insulated Wire Inc.	KPS-1503-3600-KPR	SMK RF Cables 20'	NA	8/16/13
901593	Insulated Wire Inc.	KPS-1503-360-KPR	SMK RF Cables 36"	NA	8/16/13
901242	Rhein Tech Laboratories	WRT-000-0003	Wood rotating table	N/A	N/A
901583	Agilent Technologies	N9010A	EXA Signal Analyzer (10 Hz - 26.5 GHz)	MY51250846	4/16/14
900791	Chase	CBL6111B	Bilog Antenna (30 MHz - 2000 MHz)	N/A	2/2/14
900321	EMCO	3161-03	Horn Antennas (4 - 8 GHz)	9508-1020	4/19/14
900323	EMCO	3160-07	Horn Antennas (8.2 - 12 GHz)	9605-1054	4/19/14
900356	EMCO	3160-08	Horn Antennas (12.4 - 18 GHz)	9607-1044	4/19/14
901218	EMCO	3160-09	Horn Antenna (18 - 26 GHz)	960281-003	4/19/14
900772	EMCO	3161-02	Horn Antenna (2 - 4 GHz)	9804-1044	4/19/14

Test Personnel:

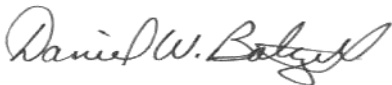
Daniel W. Baltzell EMC Test Engineer	 Signature	June 14, 2013 Date of Test
---	--	-------------------------------

10 Conclusion

The data in this measurement report shows that the **Harris Corporation Model XG-25P UHF-L, FCC ID: OWDTR-0109-E, IC: 3636B-0109**, complies with the applicable requirements of FCC Part 15 and Part 2, and IC RSS-210.