

### TX SYNTHESIZER

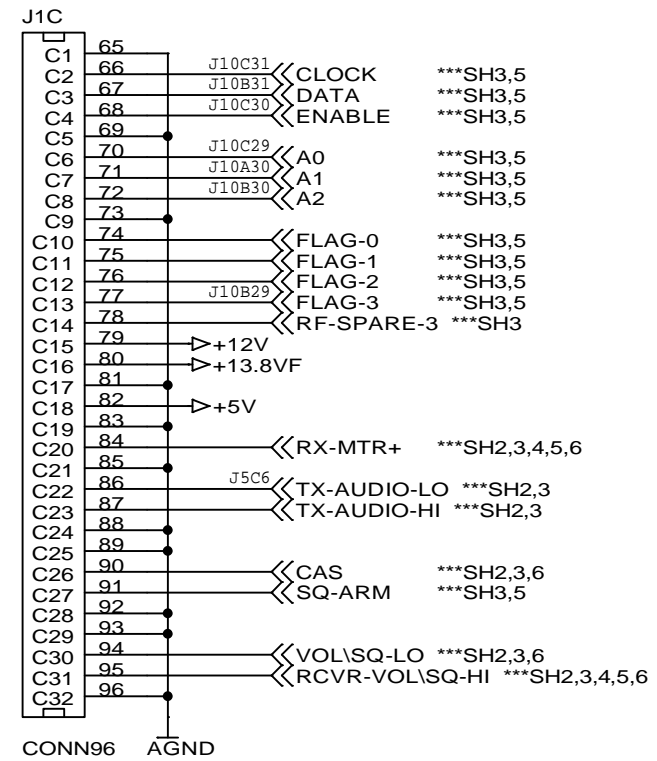

### RX SYNTHESIZER

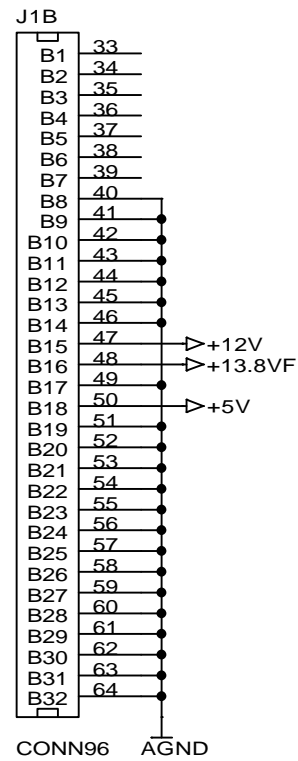
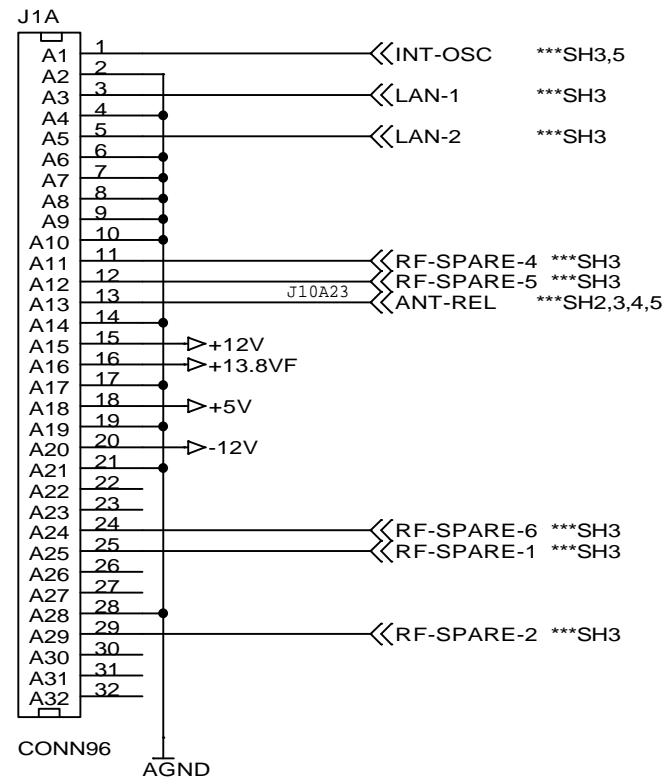
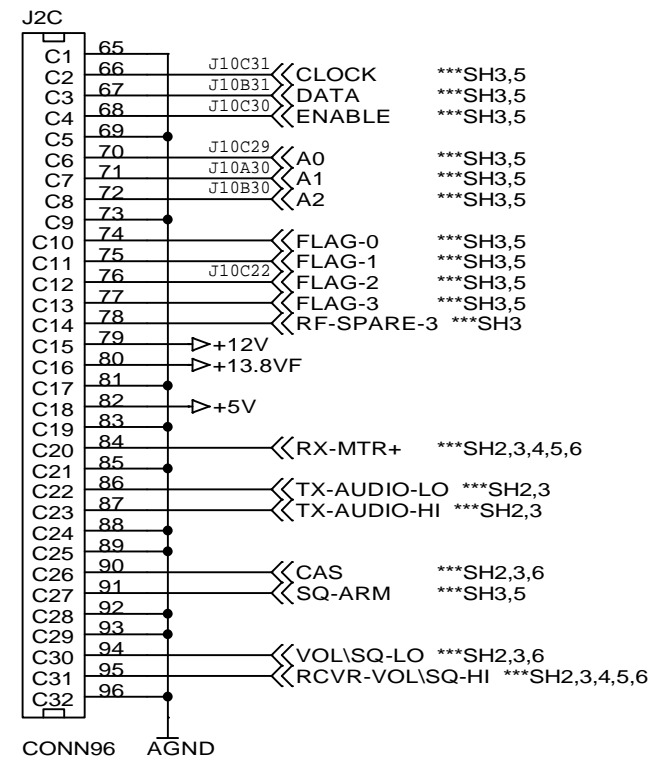
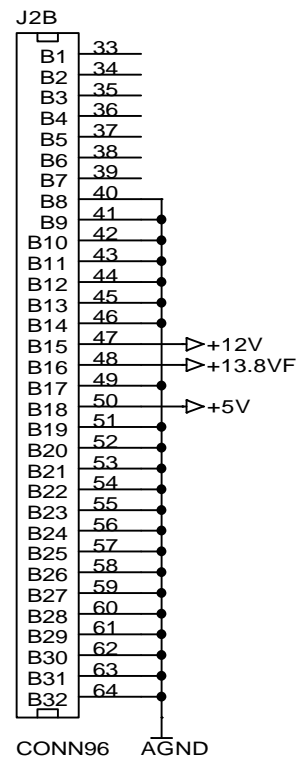
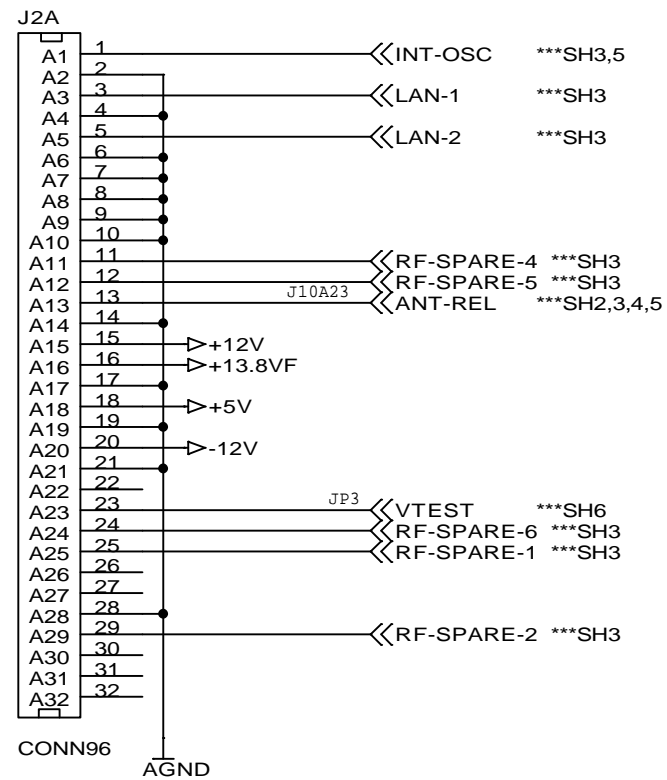

SIGNATURES	DATE	<h2 style="margin: 0;">M/A-COM Wireless Systems</h2> <h3 style="margin: 0;">MASTR III T/R SHELF BACKPLANE (A1)</h3>			
DRAWN BY					
CHECKED					
ENGRG					
ISSUED					
REVISION: PA1	SIZE <b>B</b>	FSCN NO N/A	DWGNO WD-CB101126		
May 30, 2001	SCALE				SHEET 1 OF 6

**RX FRONT END**

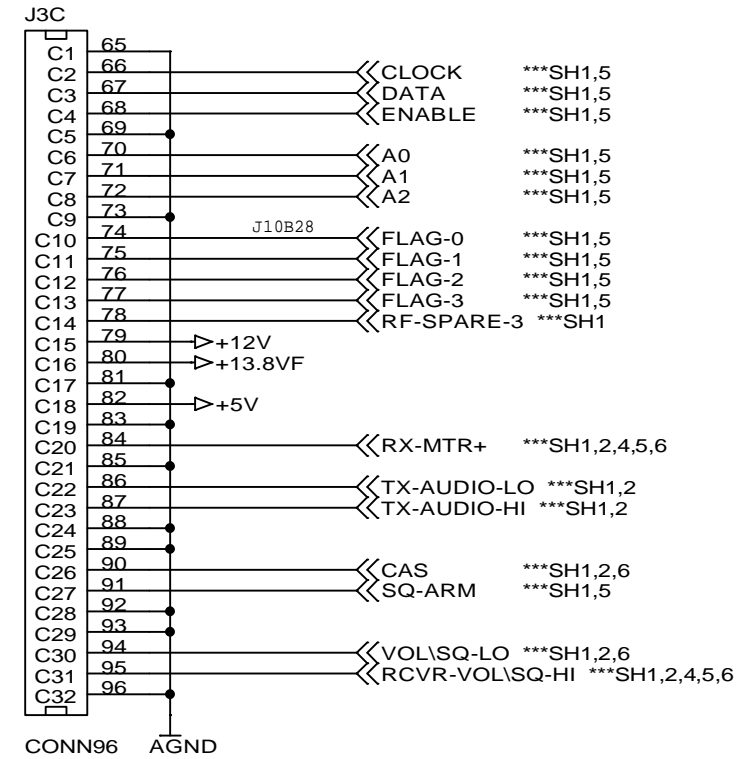
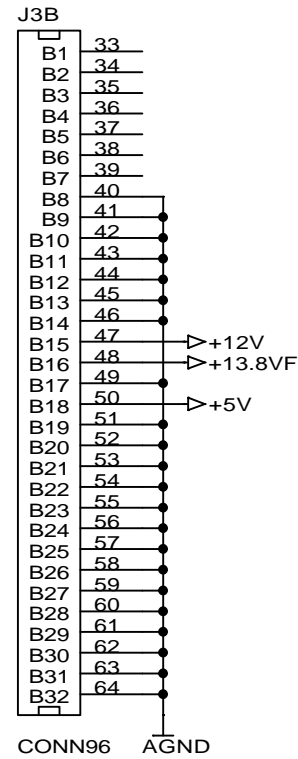
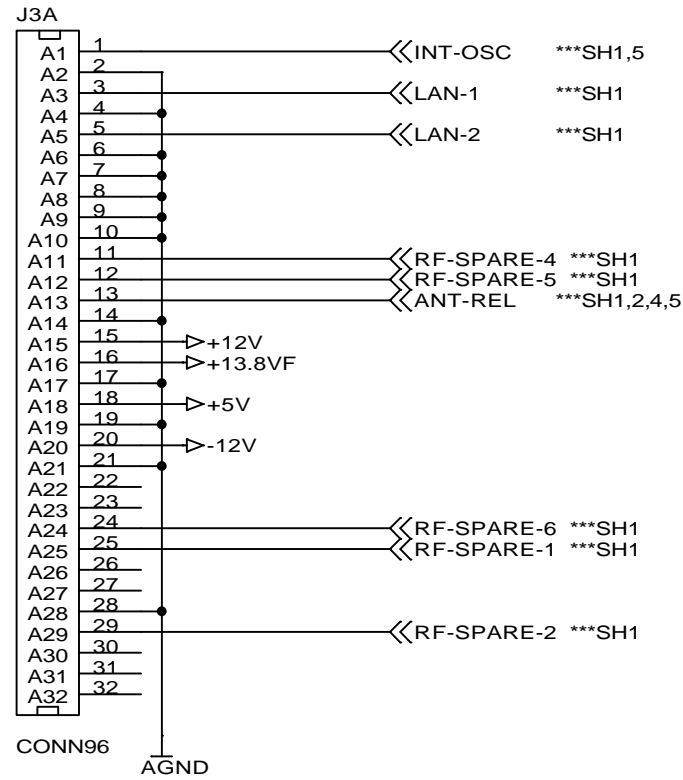

**RX IF**

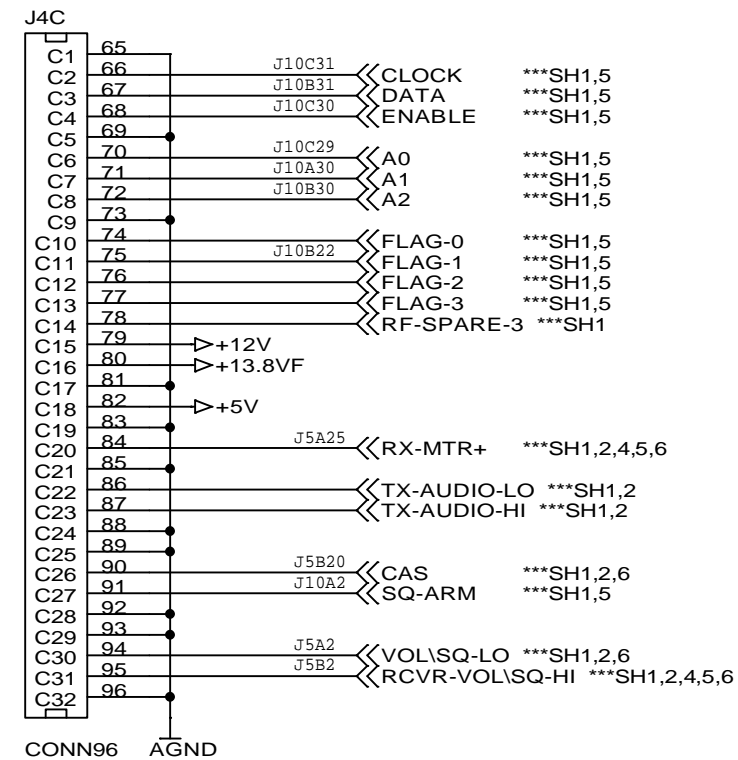
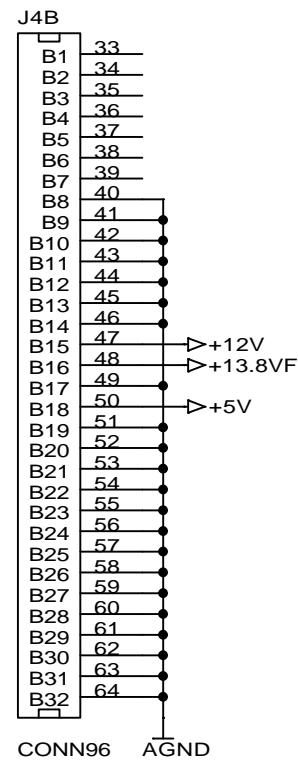
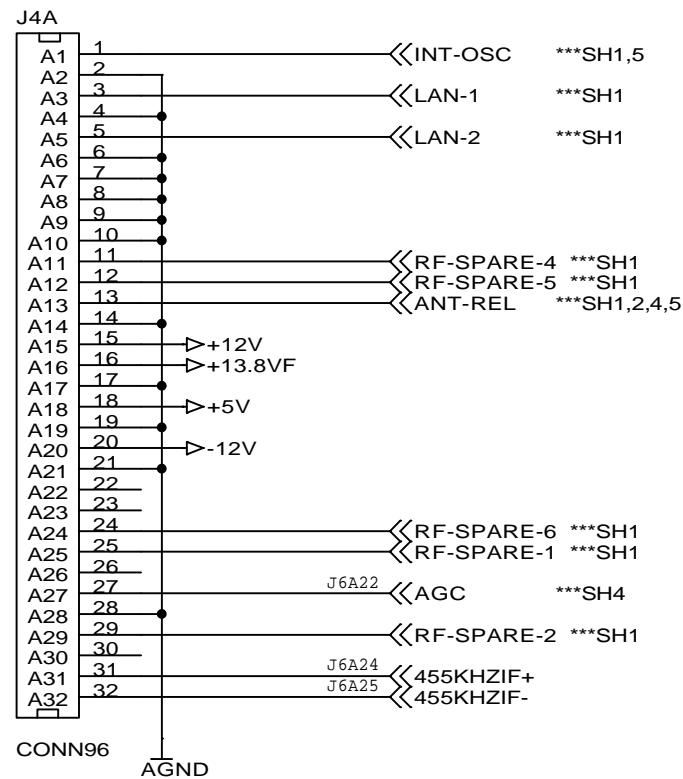

SIGNATURES	DATE	<h1 style="text-align: center;">M/A-COM Wireless Systems</h1> <h2 style="text-align: center;">MASTR III T/R SHELF BACKPLANE (A1)</h2>			
DRAWN BY					
CHECKED					
ENGRG					
ISSUED					
REVISION: PA1	SIZE <b>B</b>	FSCN NO N/A	DWG NO WD-CB101126		
May 30, 2001	SCALE				SHEET 3 OF 6

SYSTEM MODULE

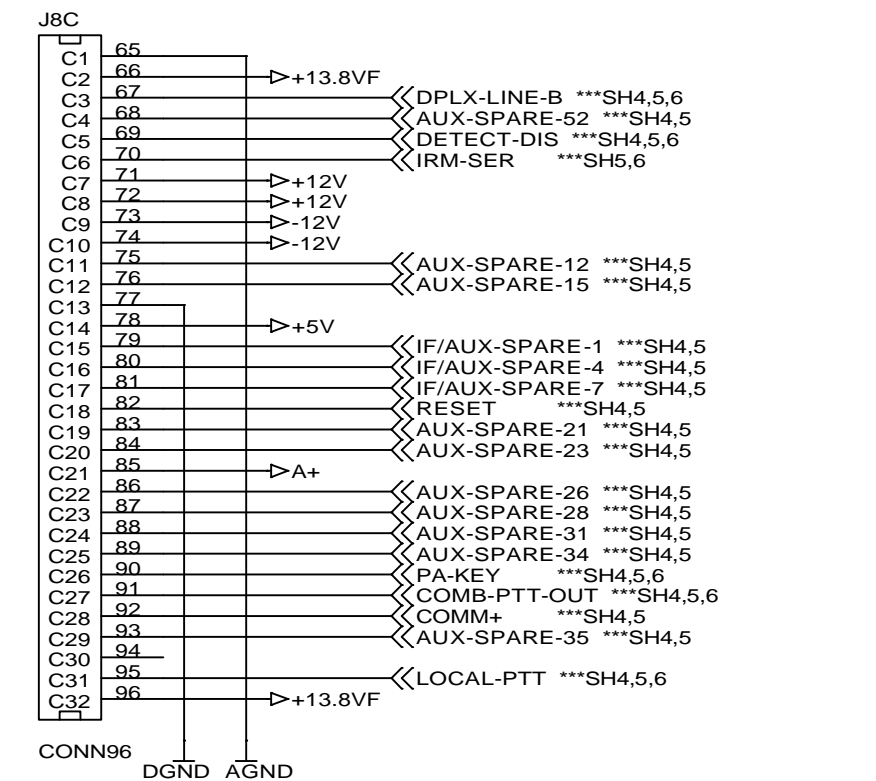
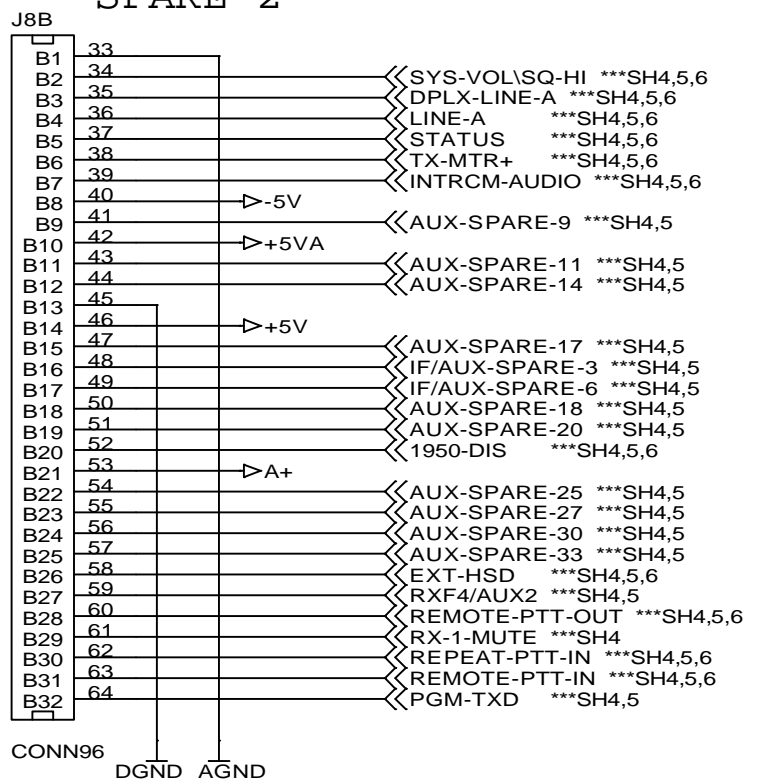
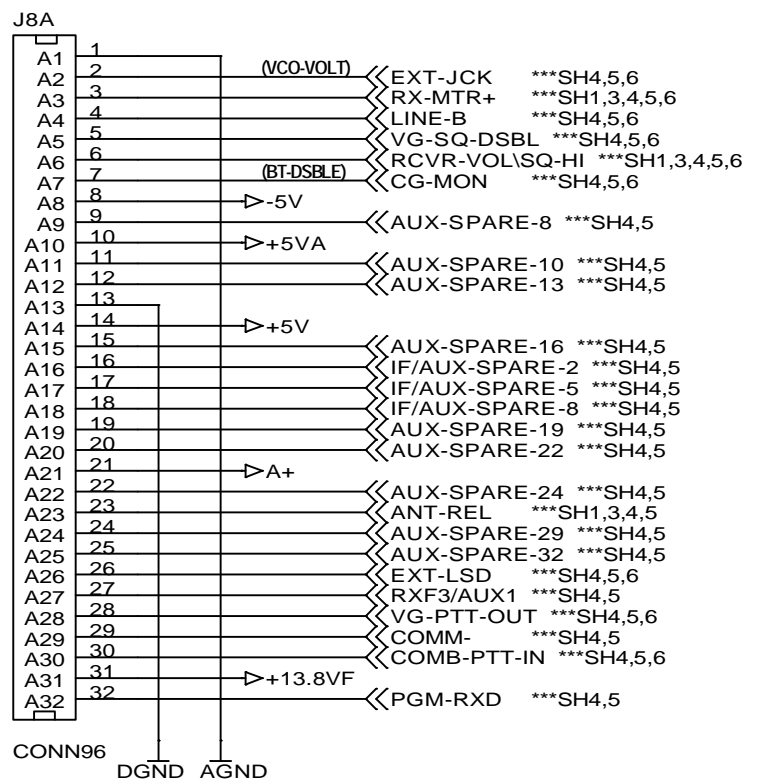
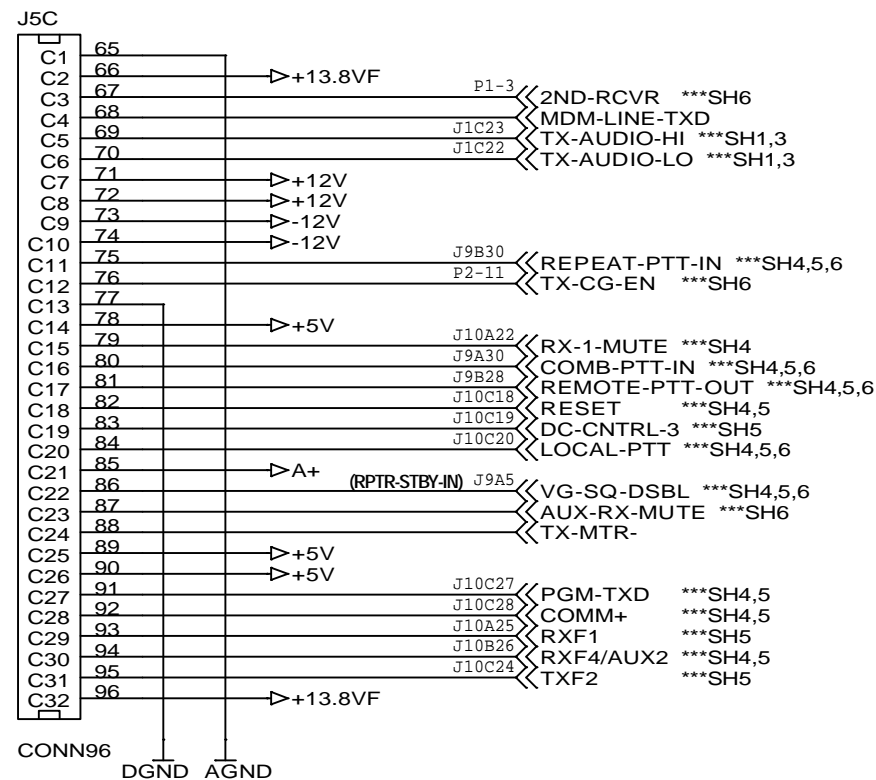
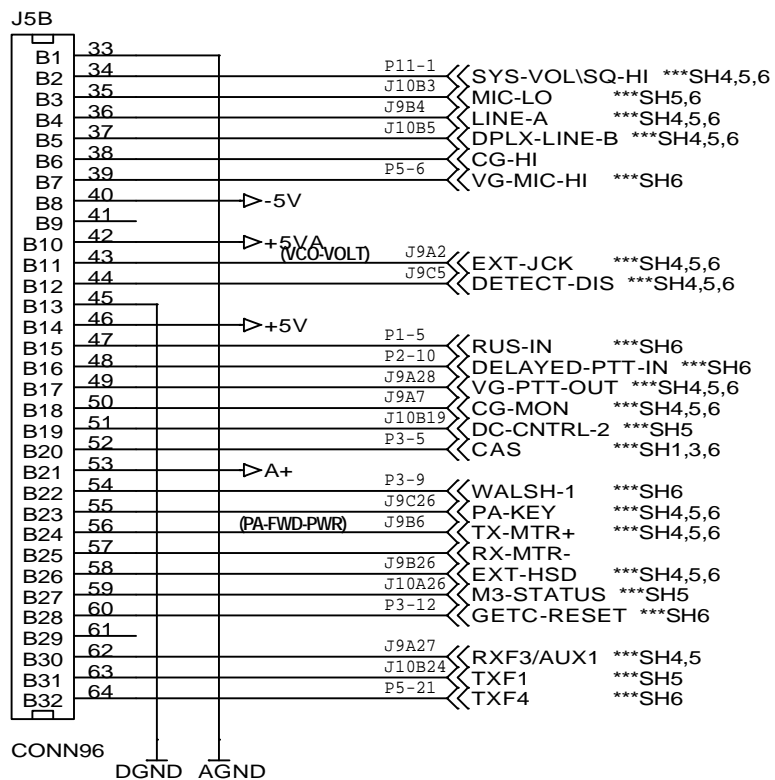
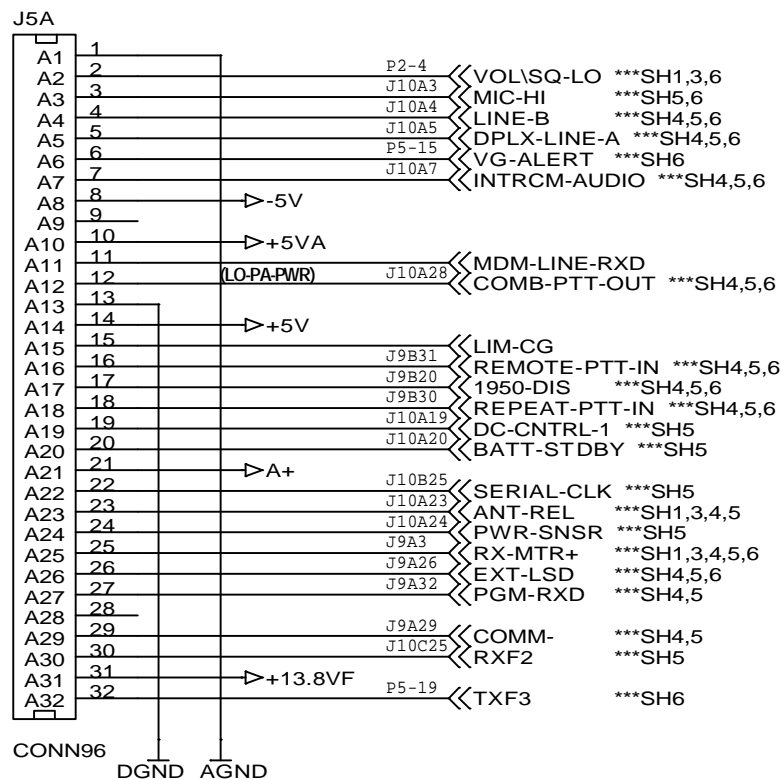

SIGNATURES		DATE		<h1>M/A-COM Wireless Systems</h1> <h2>MASTR III T/R SHELF BACKPLANE (A1)</h2>				
DRAWN BY								
CHECKED								
ENGRG								
ISSUED				REVISION: PA1		SIZE	FSCN NO	DWGNO
				May 30, 2001		B	N/A	WD-CB101126
				SCALE				SHEET
								2 OF 6

DSP MODEM

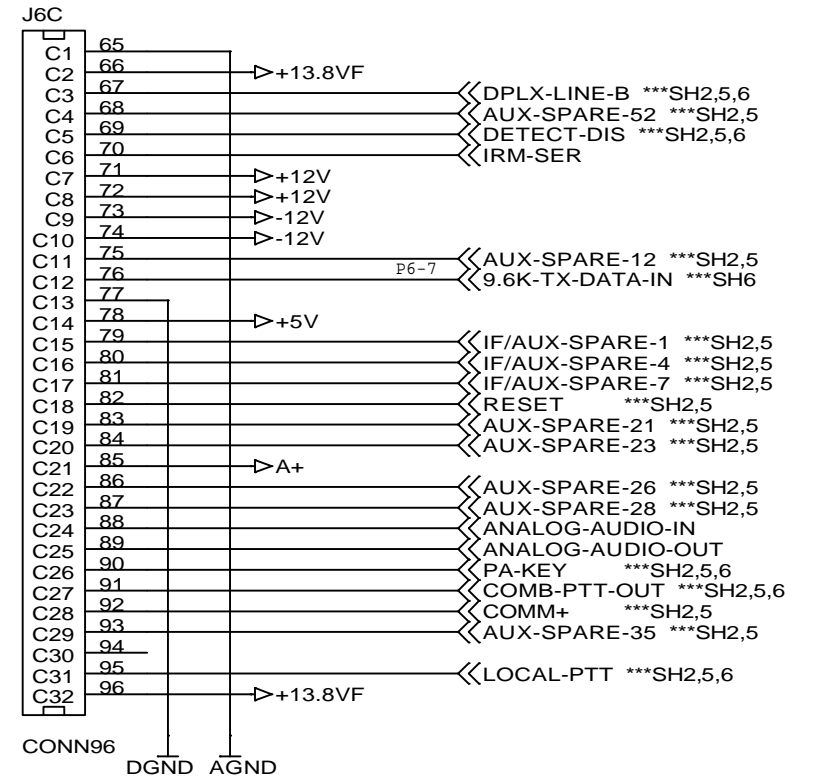
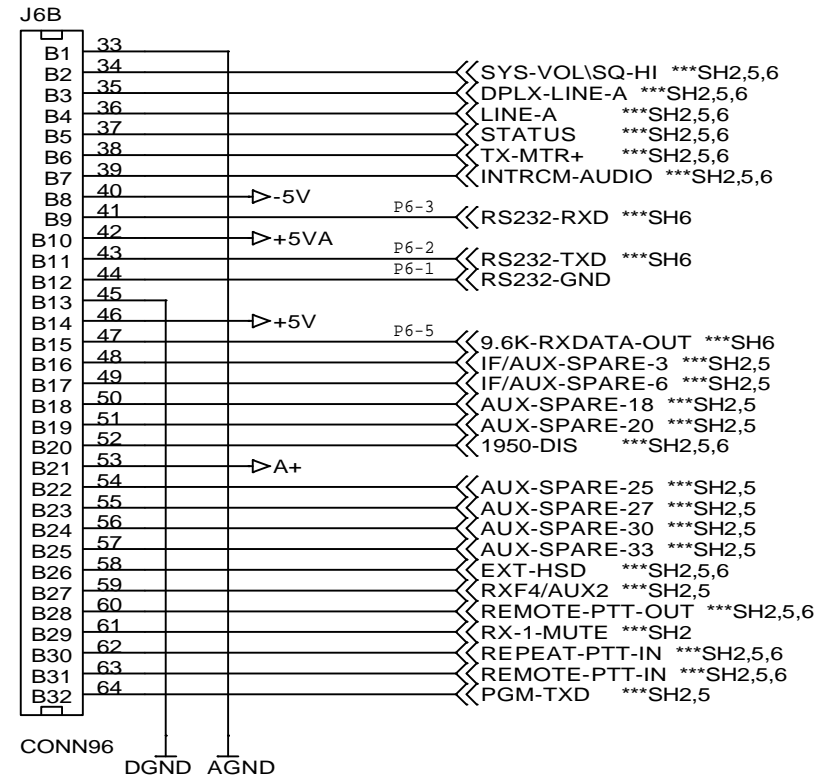
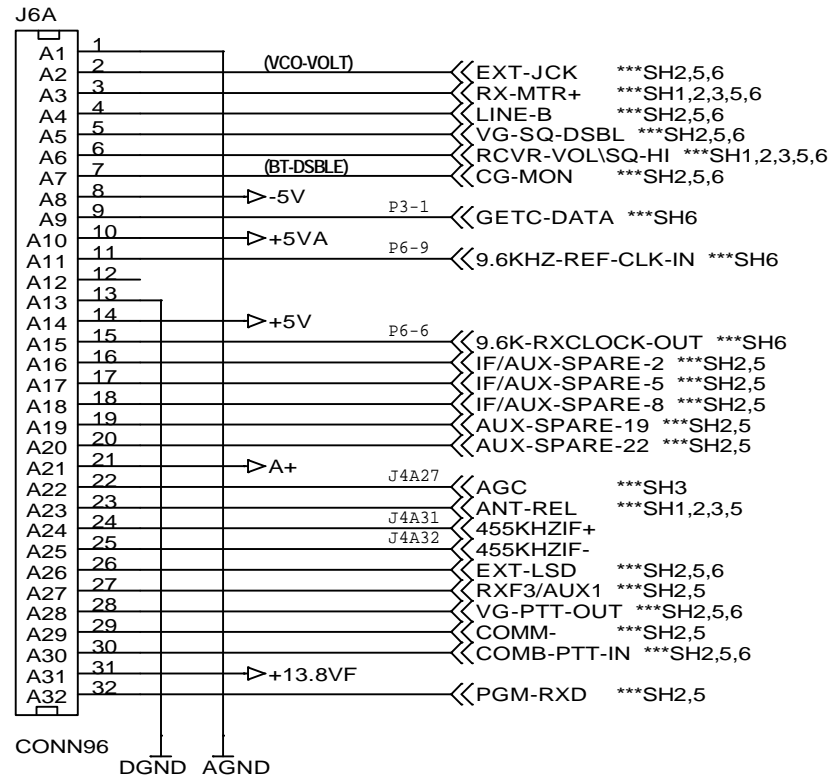

SPARE 1

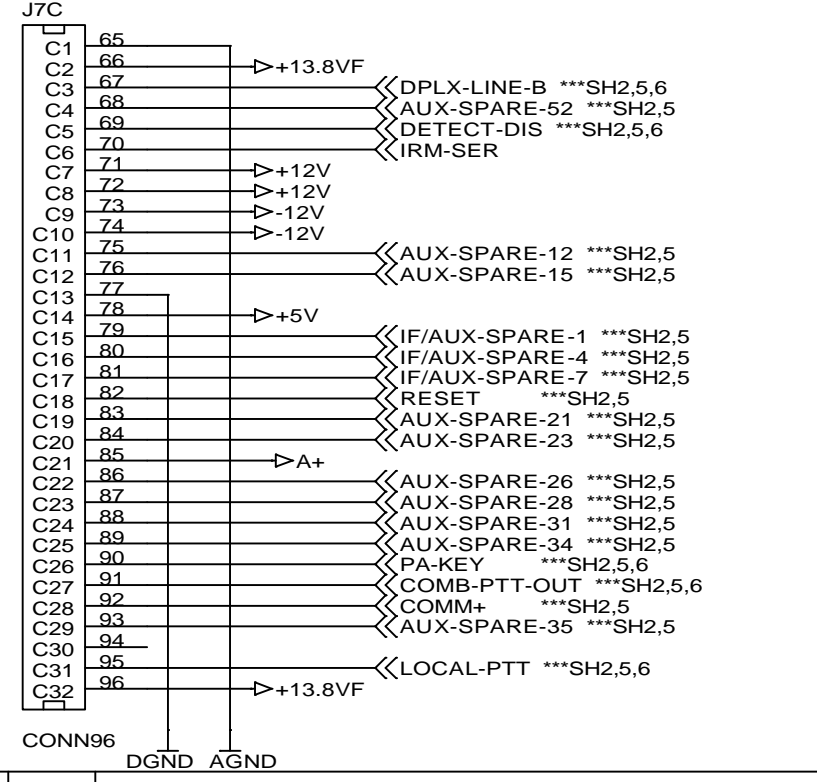
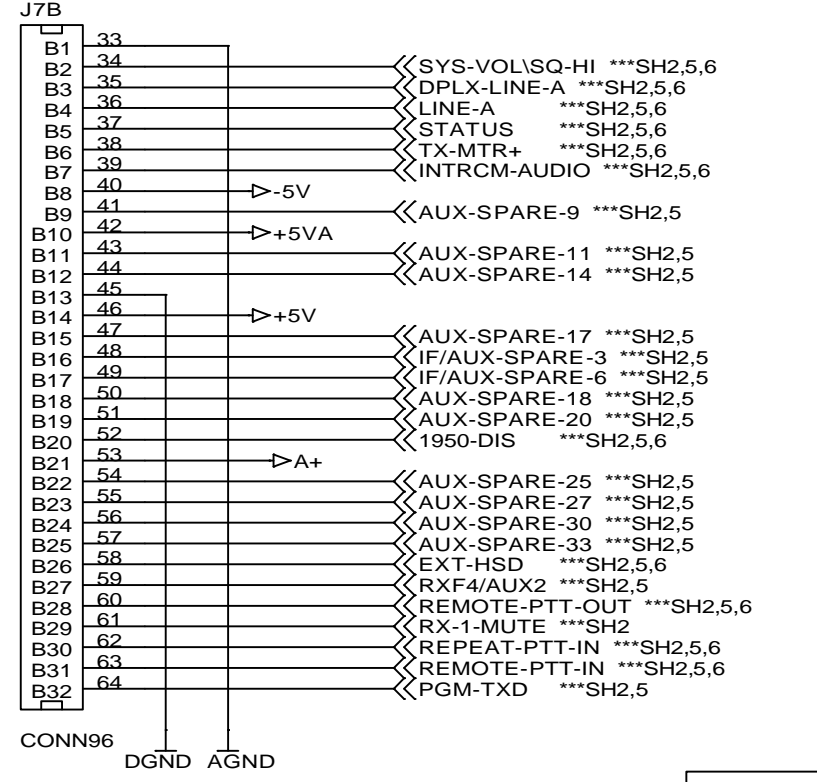
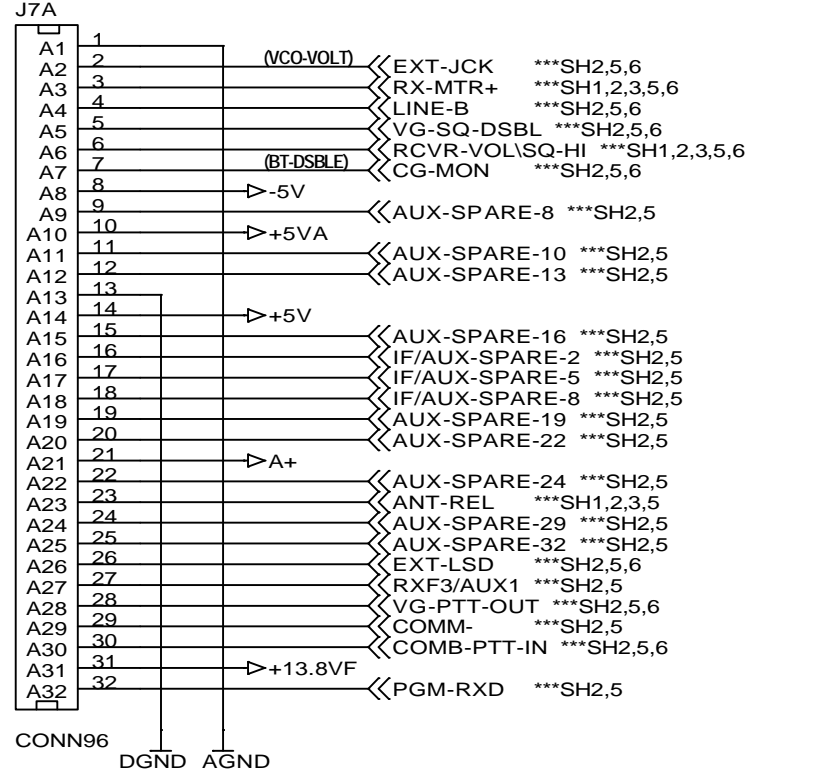

SIGNATURES		DATE	
DRAWN BY			
CHECKED			
ENGRG			
ISSUED			
<b>M/A-COM Wireless Systems</b>			
<b>MASTR III T/R SHELF BACKPLANE (A1)</b>			
REVISION: PA1	SIZE <b>B</b>	FSCN NO N/A	DWGNO WD-CB101126
May 30, 2001	SCALE		SHEET 4 OF 6

POWER MODULE

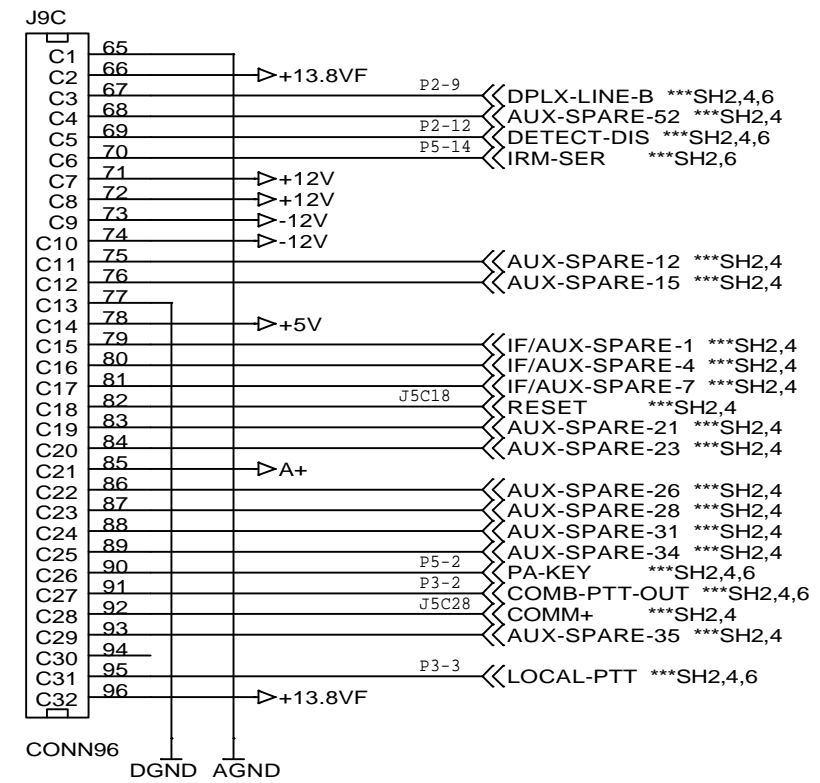
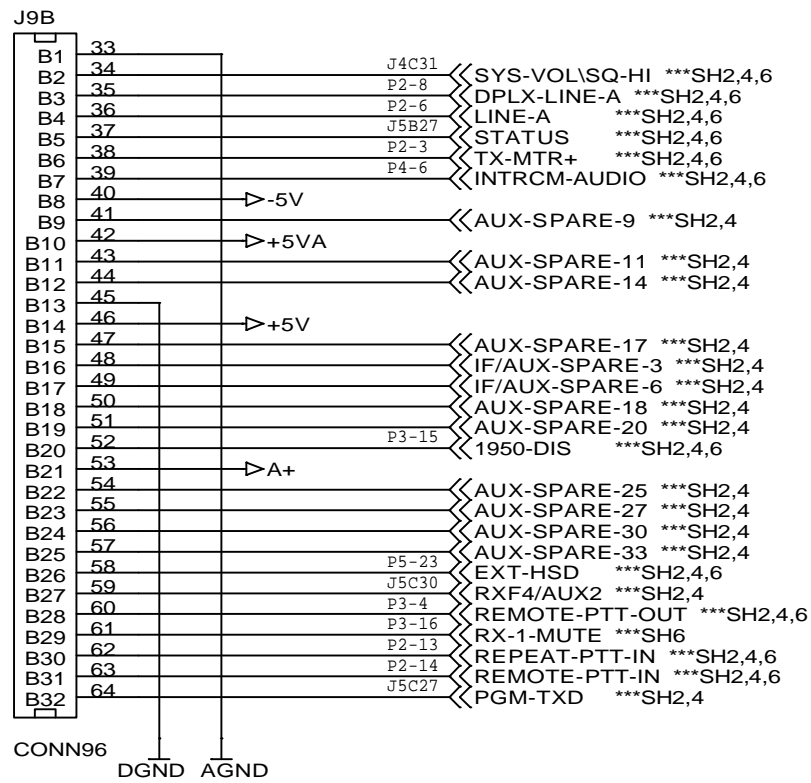
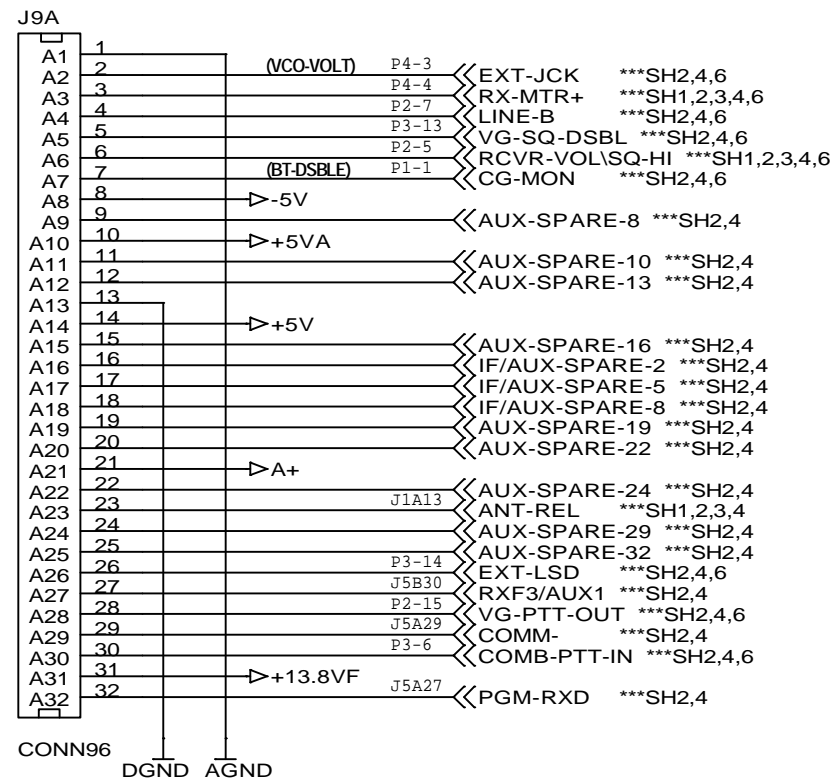

INTERFACE BOARD

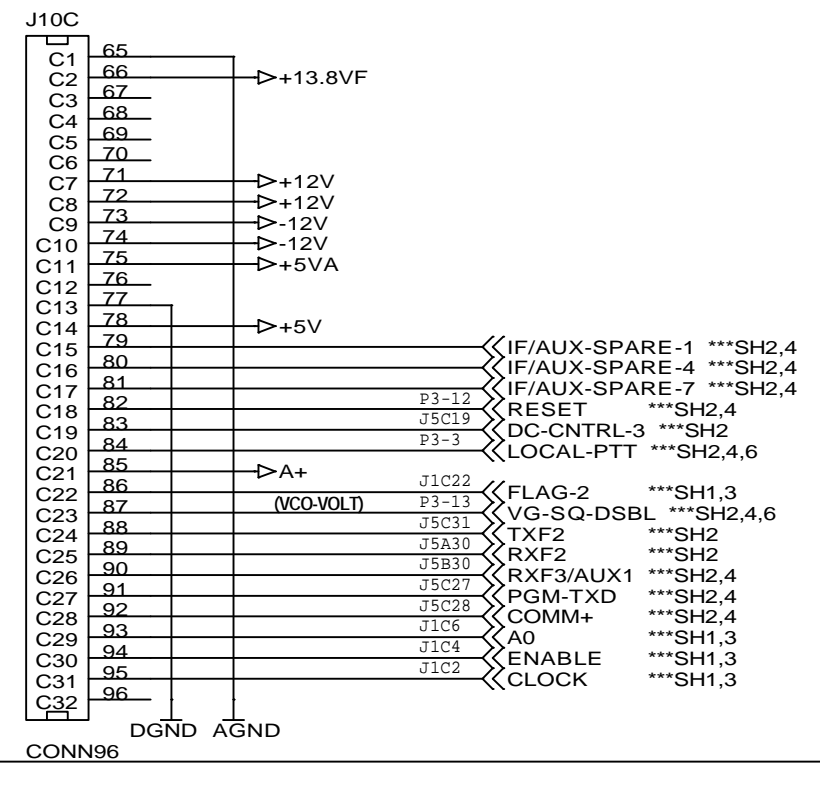
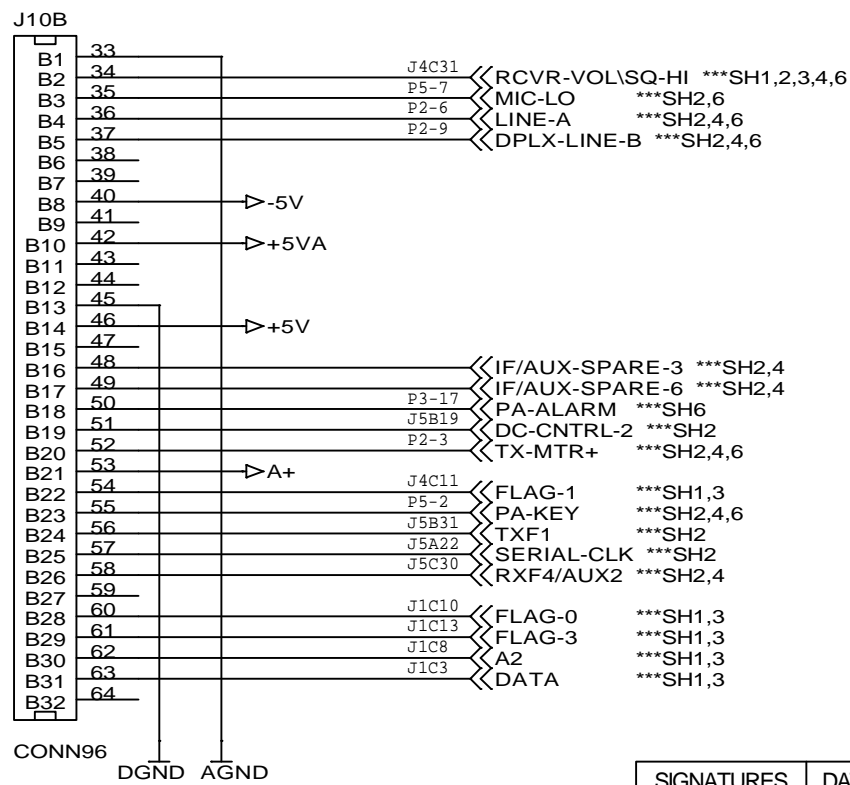
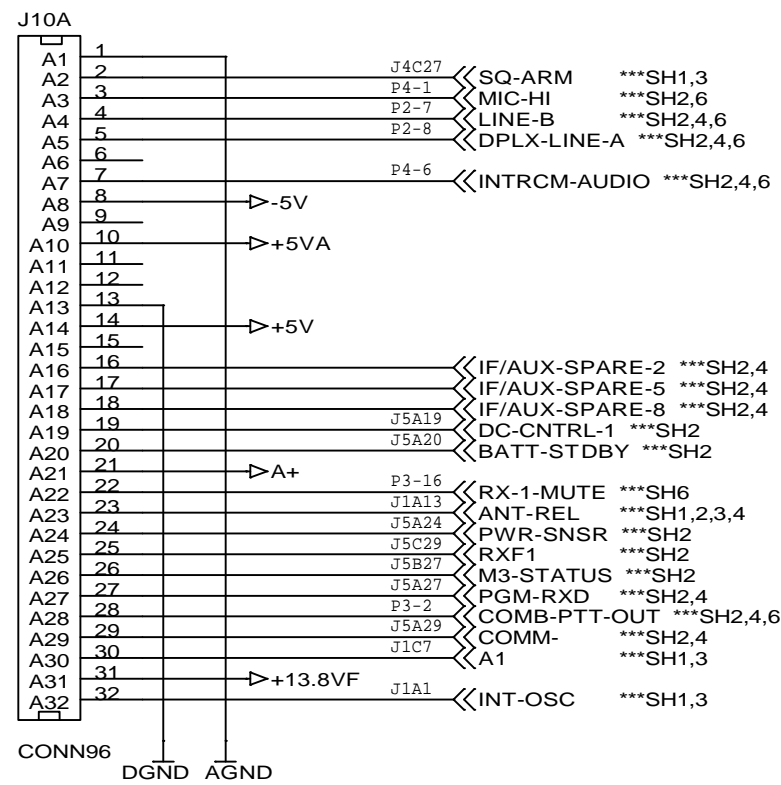

SIGNATURES	DATE	M/A-COM Wireless Systems		
DRAWN BY		<h2>MASTR III T/R SHELF BACKPLANE (A1)</h2>		
CHECKED				
ENGRG				
ISSUED				
REVISION: PA1	May 30, 2001	SIZE <b>B</b>	FSCN NO N/A	DWGNO WD-CB101126
		SCALE	SHEET 5 OF 6	

**2ND RCVR**

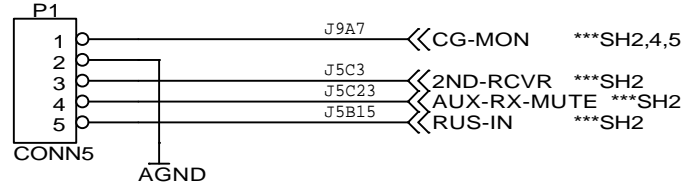

**METERING/RIC**

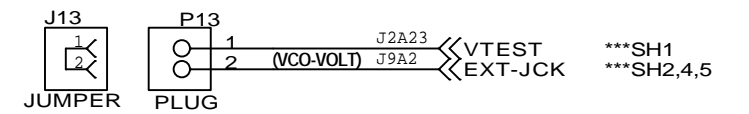
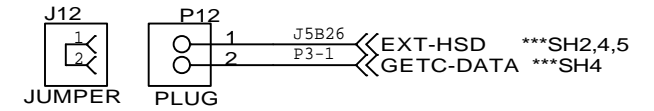
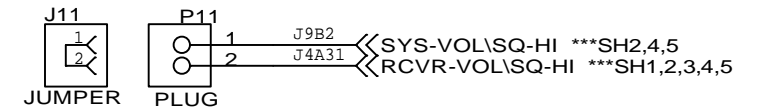
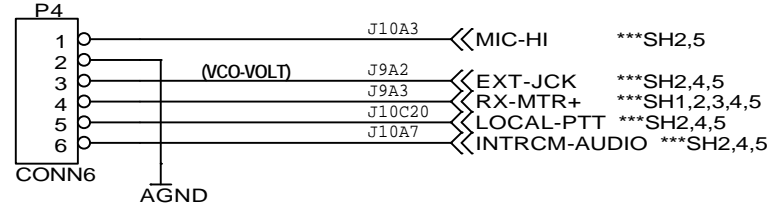

**GETC**

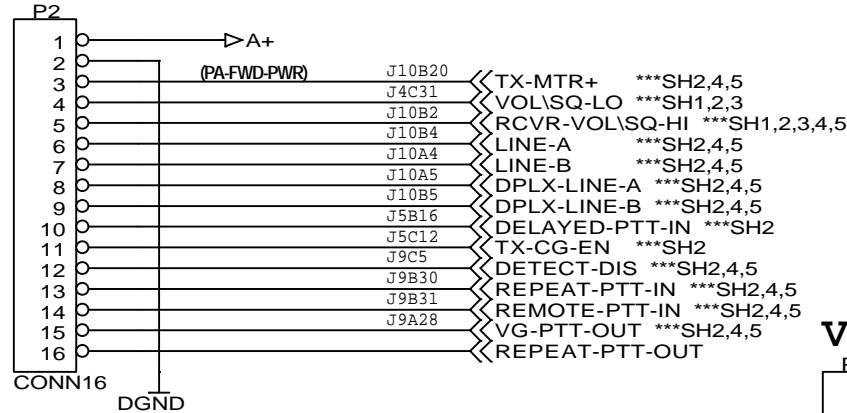

**VOICE GUARD**

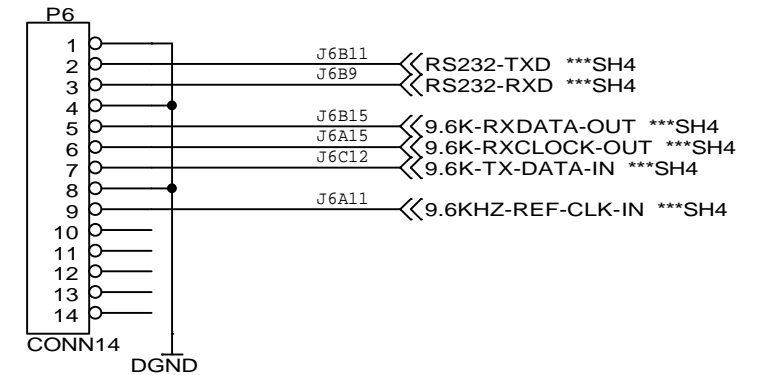
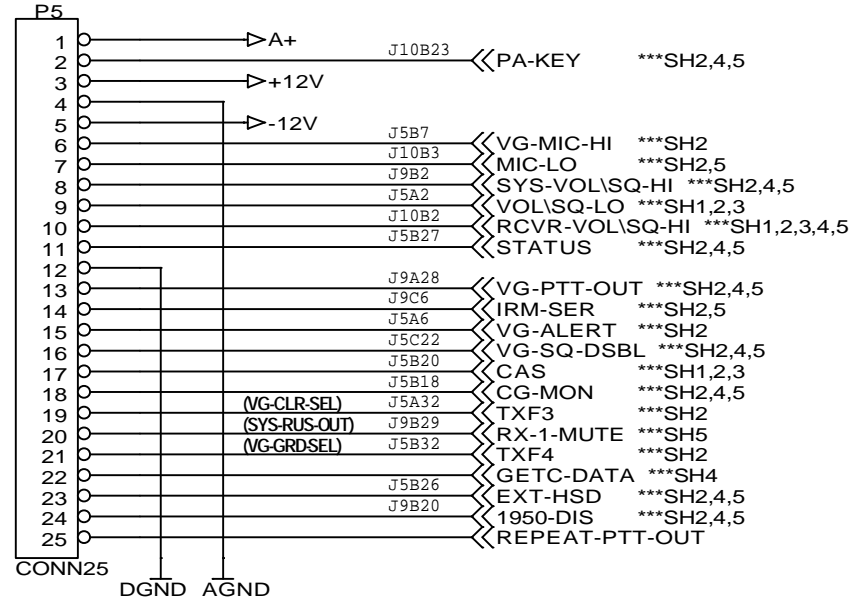

**GETC**

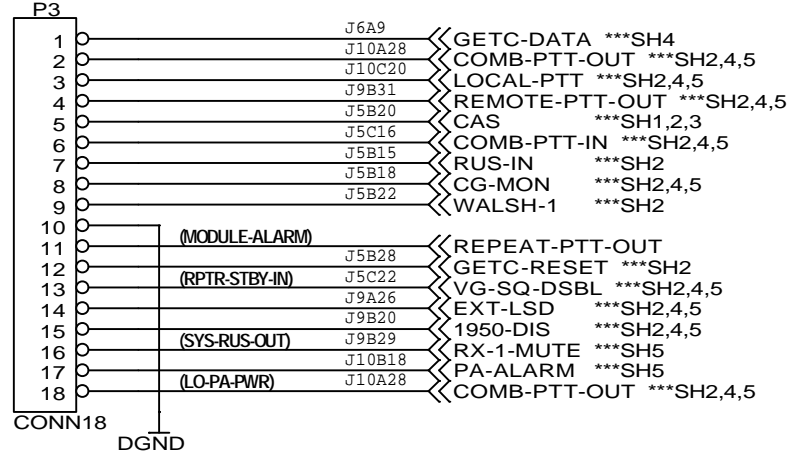

SIGNATURES	DATE	<b>M/A-COM Wireless Systems</b>		
DRAWN BY				
CHECKED				
ENGRG				
ISSUED				
<b>REVISION: PA1</b>		SIZE <b>B</b>	FSCN NO N/A	DWG NO WD-CB101126
May 30, 2001		SCALE		SHEET 6 OF 6