



360 Herndon Parkway
Suite 1400
Herndon, VA 20170
<http://www.rheintech.com>

COMPANY: Com-Net Ericsson Critical Radio Systems, Inc.
FCC ID: OWDTR-0004-A
MODEL: TR-0004-A {Panther 300M VHF (150-174 MHz)}
WORK ORDER: 2001057 / QRTL01-031 / {REV-3}

APPENDIX E: INSTALLATION MANUAL

future
The Future of Mobile Radio



PANTHER™ 300M VHF
Mobile Radio



NOTICE!

Repairs made to this equipment should be made only by an authorized service technician or facility designated by the supplier. Any repairs, alterations, or substitution of recommended parts made by the user to this equipment not approved by the manufacturer could void the user's authority to operate the equipment in addition to the manufacturer's warranty.

NOTICE!

The software contained in this device is copyrighted by Com-Net Ericsson Critical Radio Systems, Inc. Unpublished rights are reserved under the copyright laws of the United States.

This manual is published by **Com-Net Ericsson Critical Radio Systems, Inc.**, without any warranty. Improvements and changes to this manual necessitated by typographical errors, inaccuracies of current information, or improvements to programs and/or equipment, may be made by **Com-Net Ericsson Critical Radio Systems, Inc.**, at any time and without notice. Such changes will be incorporated into new editions of this manual. No part of this manual may be reproduced or transmitted in any form or by any means, electronic or mechanical, including photocopying and recording, for any purpose, without the express written permission of **Com-Net Ericsson Critical Radio Systems, Inc.**

TABLE OF CONTENTS

	<u>Page</u>
SAFETY INFORMATION	4
SAFETY TRAINING INFORMATION	5
INTRODUCTION	7
UNPACK AND CHECK THE EQUIPMENT	7
OPTIONS AND ACCESSORIES.....	8
INSTALLATION	9
STEP 1 - PLAN THE INSTALLATION	9
STEP 2 - LOCATE THE TOOLS REQUIRED.....	9
STEP 3 – EQUIPMENT PREPARATION.....	10
STEP 4 – PROGRAM THE RADIO	15
STEP 5 – INSTALL CABLES.....	16
STEP 6 – INSTALL OPTIONS AND ACCESSORIES	22

FIGURES

Figure 1 – Typical Connection Diagram.....	11
Figure 2 – Removing Top Cover	12
Figure 3 – Factory Default Internal Speaker Jumper Setting (Enabled) 13	
Figure 4 – Factory Default Settings For Jumper JP600	14
Figure 5 – Removing Plastic Cover	15
Figure 6 – Power Cable RPM 113 7674/10	17
Figure 7 – Mounting Bracket and Mounting Bracket Hardware Kit.....	20
Figure 8 – Mounting Bracket Installation	21
Figure 9 – Mounting Radio to Bracket	22
Figure 10 - Mounting the External Speaker.....	25
Figure 11 – External Speaker Option.....	26
Figure 12 – Internal/External Speaker Relay	27
Figure 13 - External Car Alert	29
Figure 14 - External Alarm Relay.....	29
Figure 15 – Ignition Sense Option	30

TABLES

Table 1 - PANTHER 300M Mobile Radio Options and Accessories	8
Table 2 – Radio Option Connector P3 Interface Description	23

SAFETY INFORMATION

The operator of any mobile radio should be aware of certain hazards common to the operation of vehicular radio transmissions. **A list of several possible hazards is given:**

1. **Explosive Atmospheres** - Just as it is dangerous to fuel a vehicle with the motor running, similar hazards exist when operating a mobile radio, be sure to turn the radio off while fueling the vehicle. Do not carry containers of fuel in the trunk of the vehicle if the radio is mounted in the trunk.
2. **Interference to Vehicular Electronics Systems** - Electronic fuel injection systems, electronic anti-skid braking systems, electronic cruise control systems, etc., are typical electronic systems that may malfunction due to the lack of protection from radio frequency energy present when transmitting. If the vehicle contains such equipment, consult the dealer and enlist their aid in determining the expected performance of electronic circuits when the radio is transmitting.
3. **Dynamite Blasting Caps** - Dynamite blasting caps may be caused to explode by operating a radio within 500 feet of the blasting caps. Always obey the "**Turn Off Two-Way Radios**" signs posted where dynamite is being used.

When transporting blasting caps in your vehicle:

- a. Carry the blasting caps in a closed metal box with a soft lining.
 - b. Leave the radio OFF whenever the blasting caps are being put into or removed from the vehicle.
4. **Liquefied Petroleum (LP) Gas Powered Vehicles** - Mobile radio installations in vehicles powered by liquefied petroleum gas with the LP gas container in the trunk or other sealed-off space within the interior of the vehicle must conform to the National Fire Protection Association standard (NFPA) 58 requiring:
 - a. The space containing the radio equipment shall be isolated by a seal from the space containing the LP gas container and its fittings.
 - b. Outside filling connections shall be used for the LP gas container.
 - c. The LP gas container shall be vented to the outside of the vehicle.

SAFETY TRAINING INFORMATION



Your Com-Net Ericsson radio generates RF electromagnetic energy during transmit mode. This radio is designed for and classified as “Occupational Use Only,” meaning it must be used only during the course of employment by individuals aware of the hazards and the ways to minimize such hazards. This radio is NOT intended for use by the “General Population” in an uncontrolled environment.

This radio has been tested and complies with the FCC RF exposure limits for “Occupational Use Only.” In addition, your Com-Net Ericsson radio complies with the following Standards and Guidelines with regard to RF energy and electromagnetic energy levels and evaluation of such levels for exposure to humans:

- FCC OET Bulletin 65 Edition 97-01 Supplement C, Evaluating Compliance with FCC Guidelines for Human Exposure to Radio Frequency Electromagnetic Fields.
- American National Standards Institute (C95.1 – 1992), IEEE Standard for Safety Levels with Respect to Human Exposure to Radio Frequency Electromagnetic Fields, 3 kHz to 300 GHz.
- American National Standards Institute (C95.3 – 1992), IEEE Recommended Practice for the Measurement of Potentially Hazardous Electromagnetic Fields – RF and Microwave.



To ensure that your exposure to RF electromagnetic energy is within the FCC allowable limits for occupational use, always adhere to the following guidelines:

- DO NOT operate the radio without a proper antenna attached, as this may damage the radio, and may also cause you to exceed FCC RF exposure limits. A proper antenna is the antenna supplied with this radio or an antenna specifically authorized by Com-Net Ericsson for use with this radio.
- DO NOT transmit for more than 50% of total radio use time (50% duty cycle). Transmitting more than 50% of the time can cause FCC RF exposure compliance requirements to be exceeded. The radio is transmitting when the “TX” LED in the radio’s display is illuminated.

Pressing the “PTT” button on the microphone will cause the radio to transmit.

- ALWAYS use Com-Net Ericsson authorized accessories (antennas, speaker/mics, etc.). Use of unauthorized accessories may cause the FCC Occupational/Controlled Exposure RF compliance requirements to be exceeded.
- ALWAYS keep at least 25 cm (10 inches) between the antenna and user/bystanders while transmitting. This radio has been tested and found to be compliant with Specific Absorption Rate (SAR) limits for uncontrolled exposure at a distance of 25 cm (10 inches) or more using a 50% duty cycle.

The information listed above is provided to make the user aware of an RF exposure and what to do to assure that this radio operates within the FCC RF exposure limits of this radio.

INTRODUCTION

The PANTHER™ 300M mobile radio is designed for installation as a front mount radio. This manual provides the mobile installation instructions and includes the instructions to install the external horn or external speaker options.

UNPACK AND CHECK THE EQUIPMENT

Carefully unpack the equipment and verify the items listed below are included in the shipping container. If damage has occurred to the equipment during shipment, file a claim with the carrier immediately. Table 1 on page 8 provides a complete list of the options and accessories available for the PANTHER 300M mobile radio.

PANTHER 300M Radios Are Shipped With The Following:

- PANTHER 300M Mobile Radio.....KRD 103 154/(1-7)
- Power Cable.....RPM 113 7674/10
- Mounting BracketKG6903
- Mounting Bracket Hardware Kit52B6032
- Operator's Manual.....MM101030V1
- Installation ManualMM101031V1

OPTIONS AND ACCESSORIES

The following table lists the options and accessories available for the Panther 300M Mobile Radio.

Table 1 - PANTHER 300M Mobile Radio Options and Accessories

DESCRIPTION	PART NUMBER	OPTION NUMBER
Microphone, Standard	KRY 101 1654/1	KAMC7J
Microphone, DTMF	KRY 101 1654/10	KAMC7K
Microphone Hanger	344A4678P1	KAMN1A
External Speaker (4 ohm, 10W)	19A149590P11	KALS1H
Option Cable	RPM 113 7674/1	KACJ7G
External Relay Kit	19A705499P1	KASU1C
Noise Suppression Kit	19A148539G1	KAPD1A
Power Cable	RPM 113 7674/10	KACJ7H
Audio Test Cable	RPM 113 2472/48	
Conventional ProGrammer Software or	AE/LZY 213 766/5	TQ3389 R9A or later
ProGrammer Software	AE/LZY 213 766/1	TQ3385 R9A or later
Radio Programming Interface Cable	RPM 113 2472/47	TQ3393
Copy Cat™ Cable, 300M-to-300M	RPM 113 2472/42	TQ3394
Copy Cat™ Cable, 300M-to-300P	RPM 113 2472/41	TQ3395

INSTALLATION

STEP 1 - PLAN THE INSTALLATION

Figure 1 shows an example of a typical connection diagram. Before beginning, plan the radio installation carefully so that it will:

- Be safe for the operator and passengers,
- Be convenient for the operator to use,
- Be neat in appearance,
- Be protected from water damage,
- Be easy to service,
- Be out of the way of auto mechanics,
- Be out of the way of passengers, and
- Allow for good air flow around the unit's cooling fins.

For passenger safety, mount the radio securely so the unit will not break loose in the event of a collision. This is especially important in station wagons, vans and similar type installations where a loose radio could be extremely dangerous to the vehicle occupants.

The procedures in this section provide a guideline for installing the mobile radio. In some applications, it may be necessary to deviate slightly from the recommended procedure and the order in which the equipment is installed.

To assure the feasibility of the cable routes you plan to use, it is suggested that you run the cables before installing the radio. Be sure to leave some slack in each cable so that the radio may be pulled out for servicing with the power applied.

It is recommended the unit be installed by one of the many Com-Net Ericsson Authorized Service Centers located throughout the United States. Personnel at these centers are experienced in installations of this type and can provide a safe, neat, and functional installation.

STEP 2 - LOCATE THE TOOLS REQUIRED

The following tools are required to install the PANTHER 300M Mobile Radio:

- Electric drill for drilling mounting holes
- Drills and circle cutters as follows:
 - No. 31 (1/8-inch) drill

- 1/2-inch drill or circle cutter
- 3/4-inch circle cutter, hole saw or socket punch
- Phillips and flat-blade screwdrivers
- No. 10 Torx® driver

Torx is a registered trademark of CAMCAR Division TEXTRON, Inc.

STEP 3 – EQUIPMENT PREPARATION

Mounting

This section describes the radio preparation for installation. In most applications, the following procedures should be completed before the radio is mounted. Depending upon the mounting location, these procedures could become very difficult after the radio is mounted. The preparation list includes:

- Configuring the Internal Speaker Jumper
- Configuring the Ignition Sense Line Jumper
- Connecting the Option Cable to the Radio

Read through the procedures provided in this section. If you are satisfied with the default factory jumper settings and your installation does not require an option cable, skip this section and go to **STEP 4 – PROGRAM THE RADIO** on page 15.

Removing the Top Cover and Shield

The top cover and shield must be removed to change the Internal Speaker jumper (JP701) or the ignition sense line jumper (JP600), to connect the option cable to the radio.

1. The top cover is secured with three screws from the bottom of the radio. Using a No. 10 Torx® driver, loosen the three screws  on the top of the radio as shown in Figure 2.
2. Remove the two control knobs from the front of the radio.
3. Pry the cover loose from the two tabs on the bottom of the radio.

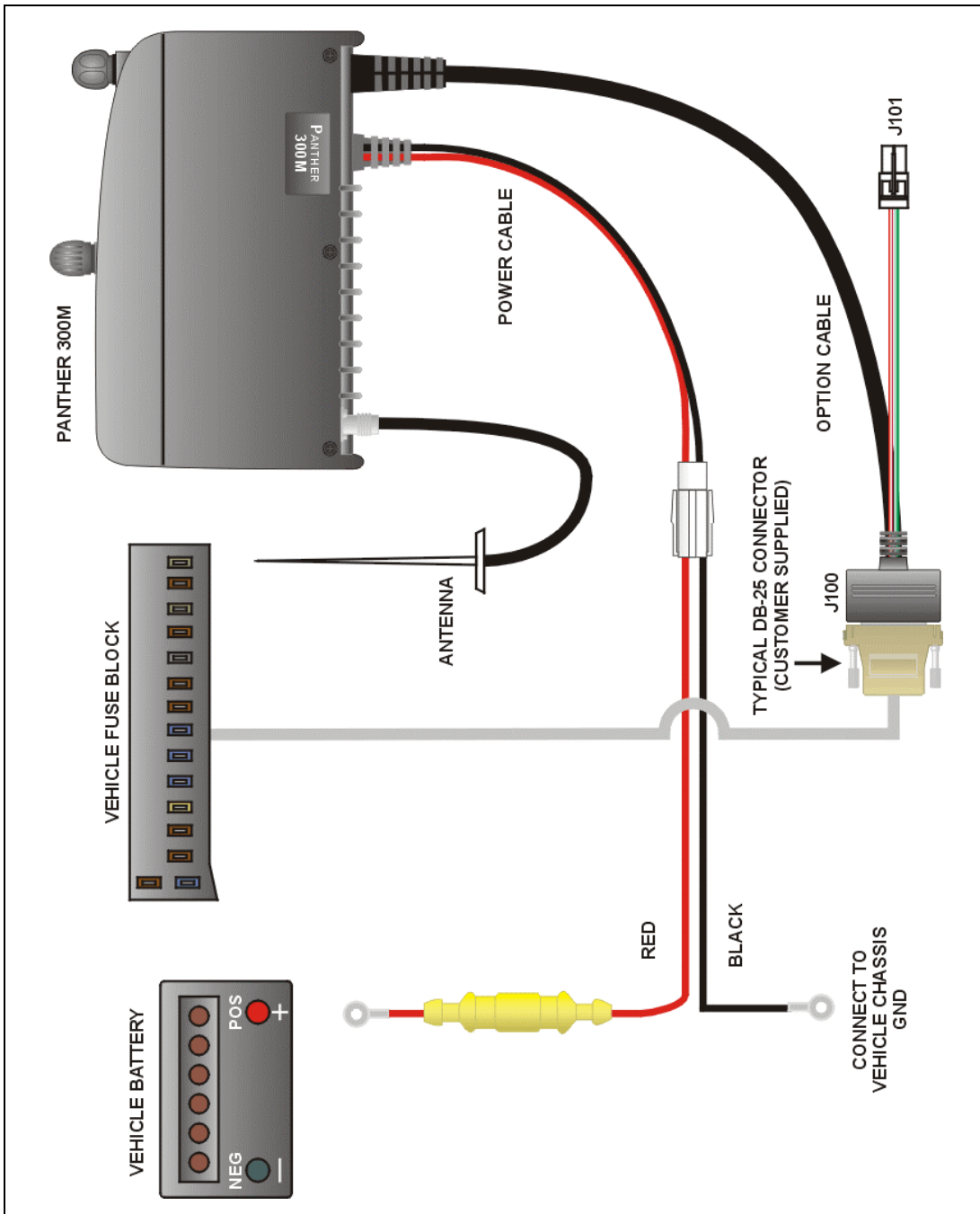

Figure 1 – Typical Connection Diagram

4. Remove the top cover by lifting the back and sliding it forward away from the chassis.

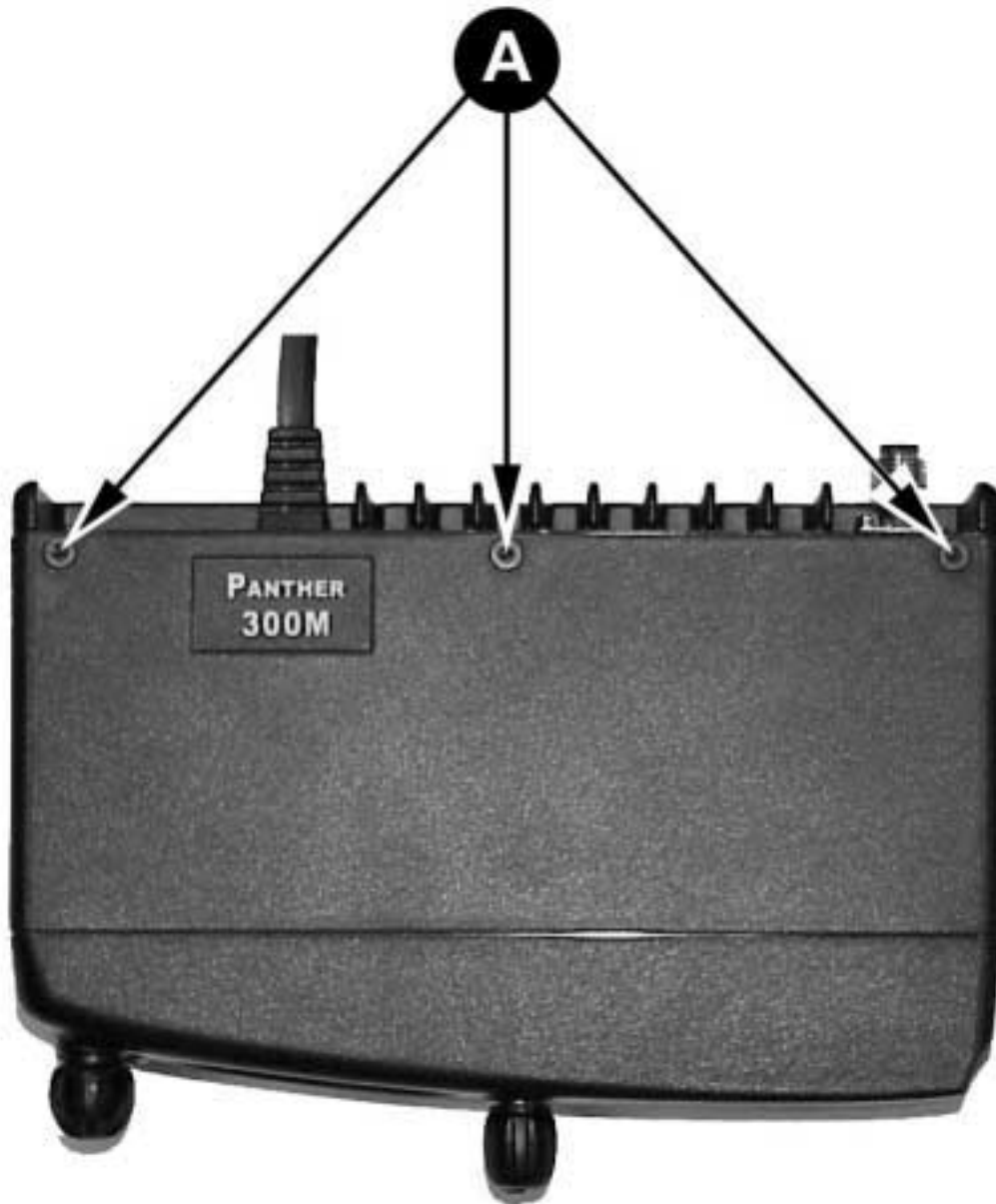

Figure 2 – Removing Top Cover

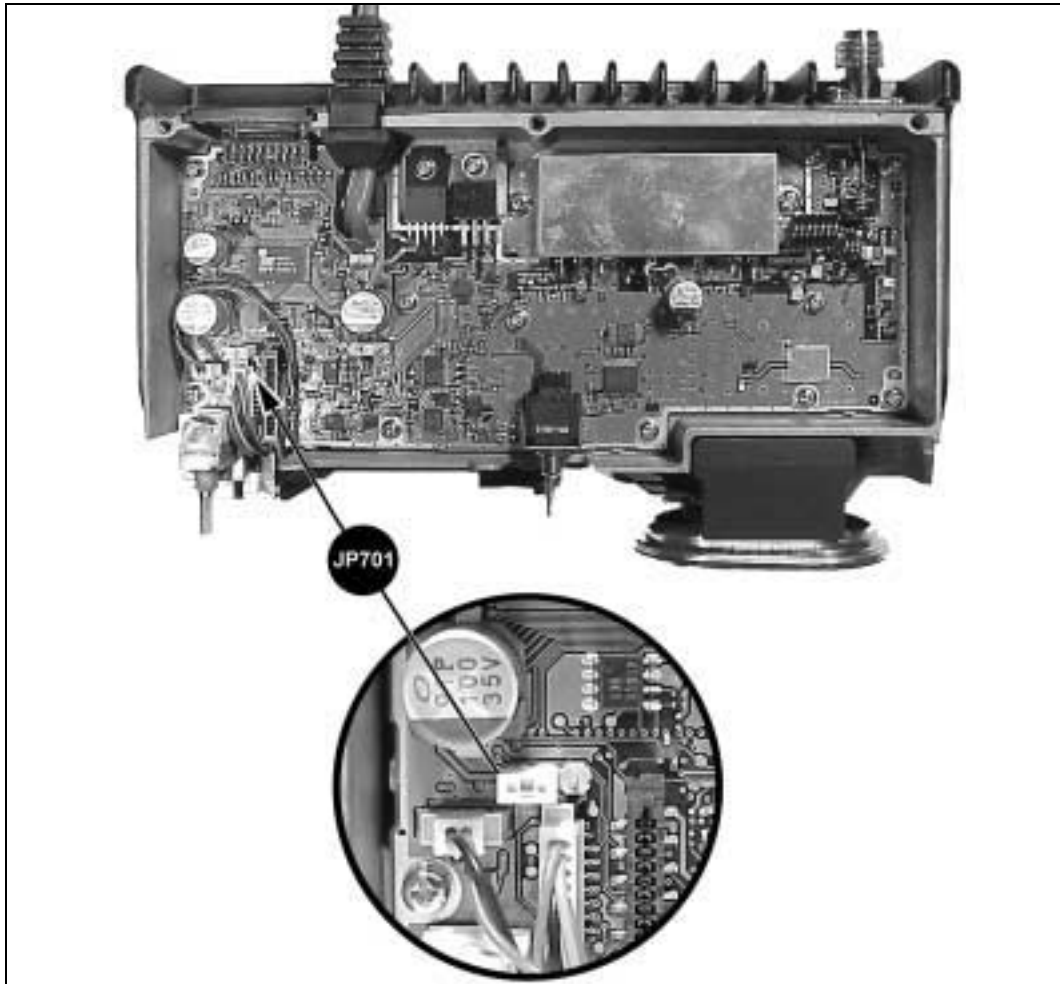

Figure 3 – Factory Default Internal Speaker Jumper Setting (Enabled)

Configure the Internal Radio Speaker Jumper (JP701)

The PANTHER 300M radio is shipped from the factory with the internal radio speaker jumper (JP701) set to 1-2 as shown in Figure 3. This setting enables the internal radio speaker. Set the jumper to 2-3 if 1) only the External Speaker is to be enabled or 2) the Internal/External Speaker option is to be enabled.

Configure Ignition Sense Jumper (JP600)

The Ignition Sense line enables or disables transmit or car horn alert option through the vehicle ignition switch. If the Ignition Sense option is desired, Ignition Sense jumper JP600 must be set to 2-3. The PANTHER 300M radio is shipped from the factory with the Ignition Sense jumper (JP600) set to 1-2 as shown in Figure 4. This default setting disables the Ignition Sense option. If your installation will not take advantage of the Ignition Sense line, skip this section and proceed to the next section.

To use the Ignition Sense line in any application, the option cable must be

wired accordingly, see the section **Connect To Ignition Sense** on page 17.

There are three parameters that define how the Ignition Sense feature will operate - a jumper on the radio (as described above), and two programmable parameters in the personality.

The programmable parameters enable/disable Transmission and/or Horn Alert with respect to the vehicle ignition switch. For more information on the personality parameters, see the On-Line Help in Conventional ProGrammer (TQ-3389 R9A or later) or ProGrammer (TQ-3385 R9A or later).

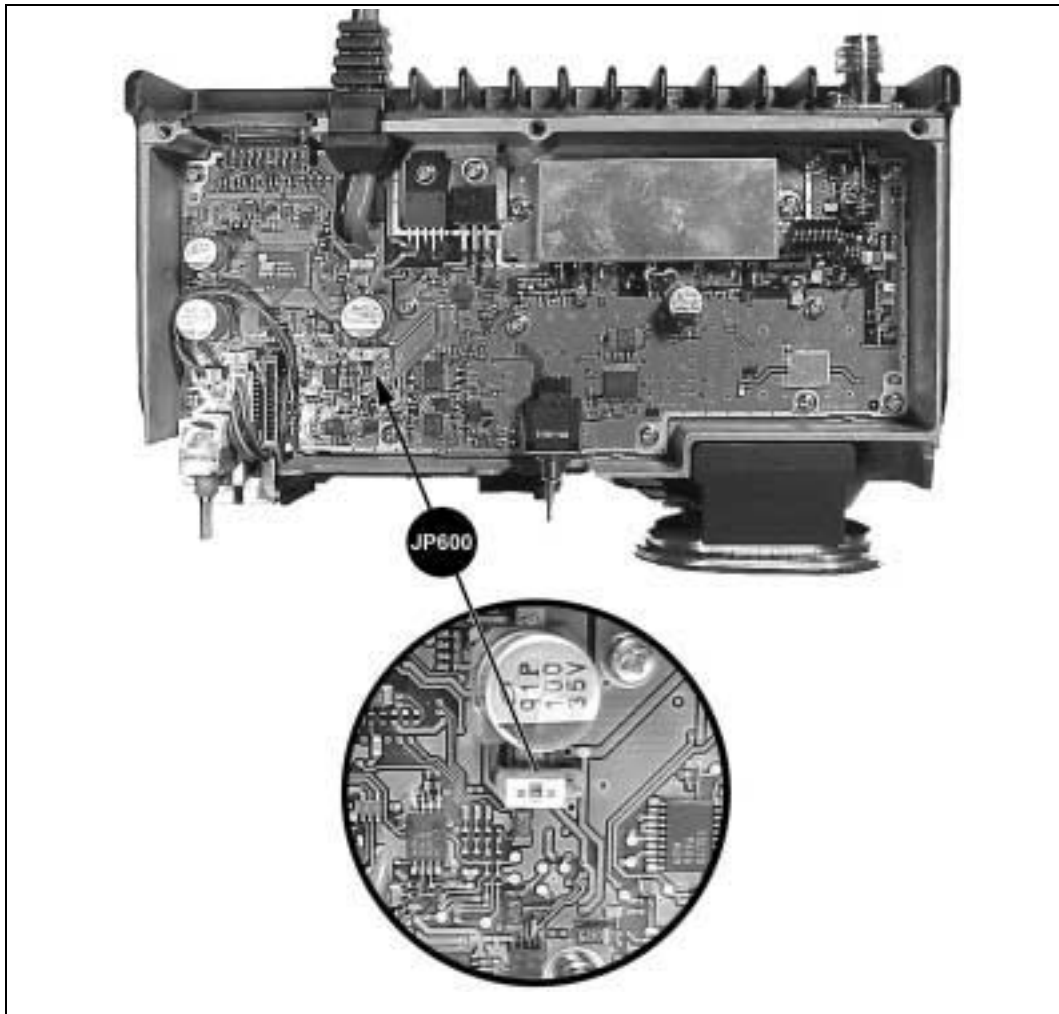

Figure 4 – Factory Default Settings For Jumper JP600

Connect Option Cable

This section applies to installations that require an option cable. The option cable (RPM 113 7674/1) is required if you are installing:

- External Speaker
- Internal/External Speaker Option
- Car Horn Alert
- Ignition Sense
- External Modulation
- External Demodulation

To connect the option cable to the radio:

1. Remove the two Phillips screws holding the plastic cover in place, from the back of the radio, see Figure 5.

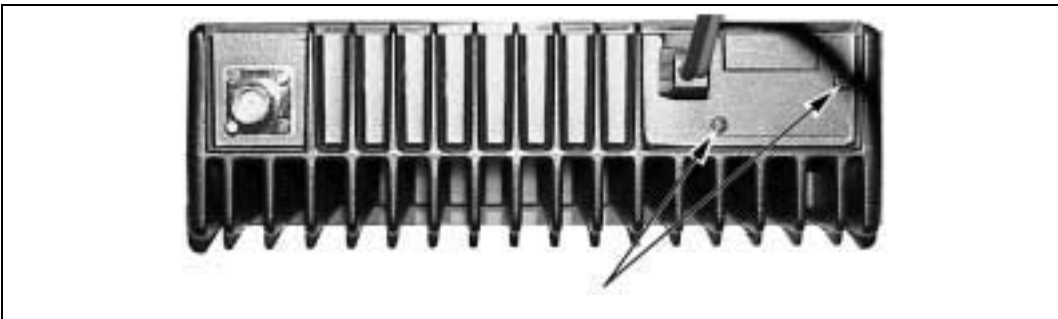

Figure 5 – Removing Plastic Cover

2. Insert the option cable through the hole left by removing the plastic cover. This will allow the connector to fit through the hole in the back of the radio.
3. Plug the option cable connector into J3 on the radio circuit board.
4. Finally, attach cable with the two Phillips screws.

STEP 4 – PROGRAM THE RADIO

All radios must be programmed with a radio personality. There are many parameters in the PANTHER 300M mobile radio that need to be setup and defined for the radio to operate appropriately for each application. Conventional ProGrammer (TQ-3389 R9A or later) or ProGrammer (TQ-3385 R9A or later) is the software used to create the personality for the PANTHER 300M radio. The radio personality is a computer file that defines all the operating parameters for the radio. For more information on programming the PANTHER 300M radio, see the On-Line Help provided with Conventional ProGrammer (TQ-3389 R9A or later) or ProGrammer (TQ-3385 R9A or later). Typically, the radio is programmed before it is installed in a vehicle.

STEP 5 – INSTALL CABLES

The PANTHER 300M Mobile Radio is installed as a front mount radio. The location of the mount, the application, and the options to be installed should be considered when planning the cable runs. The cable diagram in Figure 1 should be referenced throughout the installation process.

Power Cable

The power cable RPM 113 7674/10 consists of a two-wire cable, see Figure 6. The red fused lead supplies power to the radio directly from the vehicle battery. Ignition Sense lead, through the separate option cable, is used by the radio electronics to determine when the ignition switch is turned on. The black lead is the radio ground connection.

To install the power cable:

1. Remove the fuse from the power cable.
2. When the power cable is wired directly to the vehicle's battery, it is necessary to route the red power lead through the vehicle's firewall. If an existing hole is not conveniently located in the firewall, drill a 1/2-inch hole in the firewall for the cable run and insert a rubber grommet. This grommet is required to prevent lead chaffing. Additional grommets may be required if the leads must pass through shields or guards in the engine compartment.

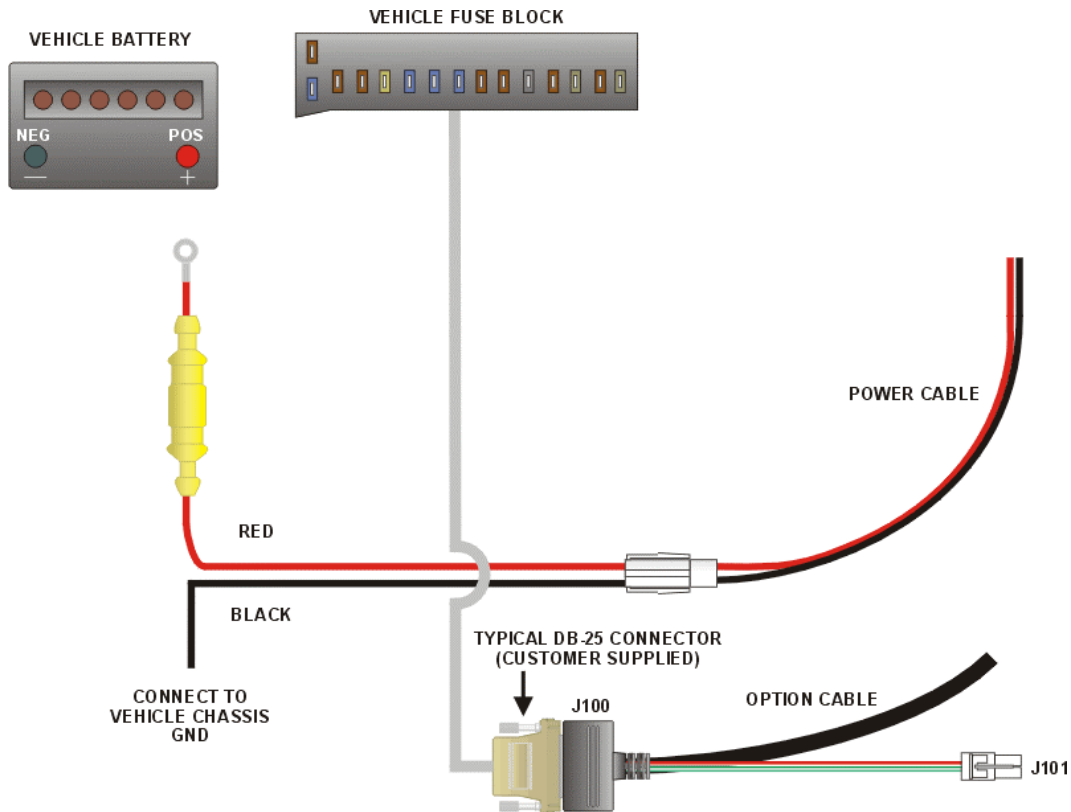

Figure 6 – Power Cable RPM 113 7674/10

Route the lead away from high heat sources in the engine compartment that may cause lead damage and introduce a fire hazard. In addition, the lead ***should not*** be routed near electrical noise sources such as electronic ignition modules or cruise control modules.

3. Secure the cable at several locations within the engine compartment to prevent possible damage to the cable.
4. Connect the BLACK lead to the vehicle chassis. Connect the lead as close to the radio as possible. DO NOT connect the BLACK lead to the “NEG” or “-“ battery post. Connect the RED lead to the positive (“POS” or “+”) battery post. See Figure 6.



The power source must have a minimum current supply capability of 13 amps.

Connect To Ignition Sense

The ignition sense line is used to enable or disable transmit or the Car Horn Alert option through the vehicle ignition switch. For a detailed description on how to configure the Ignition Sense line, see the section **Configure Ignition Sense Jumper** on page 13. Regardless of how the ignition sense line is configured, the option cable must be wired as described below for the feature to work.

Connect Pin 13 of the option cable to an ignition “ON” sense point (preferably an “Accessory” point in the vehicle fuse panel) that is switched on when the vehicle ignition switch is in the ACCESSORY and RUN positions. This lead should be connected so the vehicle fuse protection is used. See Figure 6.



The DB-25 male connector that connects to the option cable is user-supplied.

The “Accessory” point should drop to ZERO volts when cranking the engine and return to +12 volts after the engine is started. If a point is chosen that drops to a voltage between zero and +12 volts, the radio may execute a power-up cycle several times during start up. It is recommended that the terminal be measured with a voltmeter to be sure it shuts OFF (goes to zero volts) during the cranking of the engine.



Certain problems may be encountered when accessory equipment is connected to the ignition or accessory lines of the vehicle, where these lines may have large filter capacitors and a leakage path present. If the radio does not turn OFF within a reasonable amount of time after the ignition is turned off, first try a different accessory or ignition A+ pick up point in the vehicle. Many vehicles have more than one circuit that is switched by the ignition switch, and one may be available that does not have large filter capacitors or a leakage path present.

If a different pickup point cannot be found, then add a 470-ohm, 1-watt resistor from the ignition A+ pick point to ground. This will discharge the capacitor(s) or reduce the leakage voltage to a low value. Current drain through this resistor will be minimal (less than 0.03A) when the ignition is switched ON.



Figure 7 – Mounting Bracket and Mounting Bracket Hardware Kit

Radio Mounting Procedures

The following procedures are used to mount the radio.

1. Using the bracket as a template, mark and drill the mounting holes using a No. 31 (1/8) drill bit. Be sure to leave enough room at the rear of the radio unit for the cable connections and airflow.



Be careful to avoid damaging some vital part (fuel tank, transmission housing, etc.) of the vehicle when drilling mounting holes. Always check to see how far the mounting screws will extend below the mounting surface before installing.

If pilot holes must be drilled, remove all metal shavings from drilling holes before installing screws.

2. Mount the bracket using the four 3/4" Phillips sheet metal screws and spacers provided in the mounting bracket hardware kit. (Refer to Figure 8.)

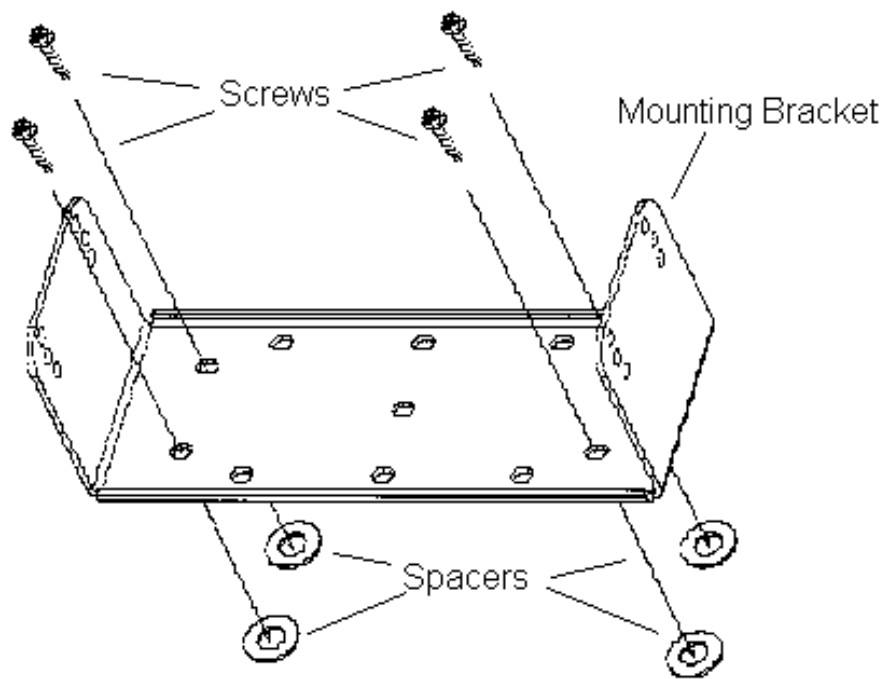

Figure 8 – Mounting Bracket Installation

3. Place the radio into the mounting bracket and secure with the four 3/8” Phillip’s screws supplied. The radio can be fastened in any of three different positions: parallel to the mounting surface or tilted slightly from the parallel position. (Refer to Figure 9.)
4. Connect antenna coaxial cable to antenna connector (TNC).
5. Insert power cable into power connector running from rear of radio unit and push until the connectors snap together.
6. Recheck all connections and then reinsert fuse into the fuse assembly on the power cable.

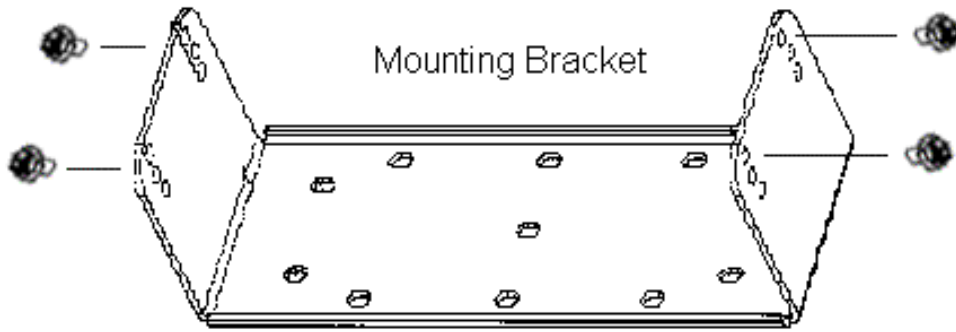

Figure 9 – Mounting Radio to Bracket

STEP 6 – INSTALL OPTIONS AND ACCESSORIES

Radio Option Cable

The radio option cable (RPM 113 7674/1) is required if you are installing:

- External Speaker
- Car Horn Alert
- External Modulation
- Internal/External Speaker Option
- Ignition Sense
- External Demodulation

The section **STEP 3 – EQUIPMENT PREPARATION**, on page 10, describes how to connect the option cable to the radio. The other end of the option cable consists of a standard female DB-25 connector, which is used to connect to the optional accessories listed above. Table 2 provides a description for each input and output on the radio option connector J603.

Table 2 – Radio Option Connector P3 Interface Description

DB-25 PIN NO (J100)	PIN NO (P3)	I/O	DESCRIPTION
2	1	---	Ground: <input type="checkbox"/> Audio Ground
5	2	I	Internal Speaker Input #1: <input type="checkbox"/> 5W across Internal Speaker
6	3	O	Audio Amp Output #1: <input type="checkbox"/> $V_o \approx 6.6$ VDC
18	4	O	Audio Amp Output #2 to Internal or External Speaker <input type="checkbox"/> $V_o \approx 6.6$ VDC; 10W maximum across External Speaker
19	5	I	External Mic Input: <input type="checkbox"/> 300-3000 Hz <input type="checkbox"/> Input level @ 1kHz for 60% of RSD: 82 ± 28 mV _{RMS} (if external audio source has $R_o=600\Omega$) <input type="checkbox"/> Input level @ 1kHz for 60% of RSD: 41 ± 14 m V _{RMS} (if external audio source has $R_o<1\Omega$)
7	6	I	External Mod Input: <input type="checkbox"/> 5-10,000 Hz (3 db BW) <input type="checkbox"/> Modulation-Sensitivity: 4.2 kHz/V _{rms} \pm 3dB
20	7	O	Switched DC Output: <input type="checkbox"/> $I_{cc}=500$ mA Max
8	8	I	Push To Talk: <input type="checkbox"/> TX ON: Low <input type="checkbox"/> TX OFF: Open
21	9	I	Mic Hookswitch: <input type="checkbox"/> “Disable” or “Enable” is selected by PC Programmer <input type="checkbox"/> Hookswitch ON: Low <input type="checkbox"/> Hookswitch OFF: Open
9	10	O	Rx Discriminator Detect Audio: <input type="checkbox"/> 20-4,000 Hz (3 dB Bandwidth) <input type="checkbox"/> 75 m V _{RMS} \pm 3 dB into a 10K ohm load
22	11	---	Ground
10	12	I	Internal Mic Mute: <input type="checkbox"/> Mute ON: Low <input type="checkbox"/> Mute OFF: Open
23	13	O	Radio UnSquelch: <input type="checkbox"/> Squelch Open: Low <input type="checkbox"/> Squelch Close: High <input type="checkbox"/> $RL = 4.7$ kohms
11	14		Spare

Table 2 - Radio Option Connector P3 Interface Description Cont'd

DB-25 PIN NO (J100)	PIN NO (P3)	I/O	DESCRIPTION						
24	15	O	<p>(1) HORN CONTROL At Signaling Mode</p> <table border="0"> <tr> <td style="text-align: center;"><u>Display In Menu</u></td> <td style="text-align: center;"><u>Action</u></td> </tr> <tr> <td style="text-align: center;">On</td> <td style="text-align: center;">Enable</td> </tr> <tr> <td style="text-align: center;">Off</td> <td style="text-align: center;">Disable</td> </tr> </table> <ul style="list-style-type: none"> <input type="checkbox"/> When select “ON”(enable) and a correct T99 Individual Call is received, the output of pin 15 is “low.” <input type="checkbox"/> Horn Alarm ON : Low <input type="checkbox"/> Horn Alarm OFF: Open <p>(2) SPEAKER SELECT INTERNAL/EXTERNAL</p> <ul style="list-style-type: none"> <input type="checkbox"/> Enabling or disabling of the Internal/External Speaker option is done by proper setting of an internal jumper in the mobile radio. <input type="checkbox"/> Internal: Low <input type="checkbox"/> External: Open <input type="checkbox"/> For relay control Io_max = 150mA <input type="checkbox"/> **“HORN CONTROL” or “SPEAKER SELECT” is selected by PC ProGrammer. <p>Note: Internal and external speaker do not operate simultaneously.</p>	<u>Display In Menu</u>	<u>Action</u>	On	Enable	Off	Disable
<u>Display In Menu</u>	<u>Action</u>								
On	Enable								
Off	Disable								
12	16	I	<p>Data Communication Input (Test Mode)</p> <ul style="list-style-type: none"> <input type="checkbox"/> TTL Level 						
25	17	O	<p>Data Communication Output (Test Mode)</p> <ul style="list-style-type: none"> <input type="checkbox"/> TTL Level 						
13	18	I	<p>Ignition Sense</p> <ul style="list-style-type: none"> <input type="checkbox"/> 13.6VDC <input type="checkbox"/> Io_max = 100 mA 						



Internal Mic Mute (DB25-10) must be grounded when applying audio to external Mic Input (DB25-19).

External Mic Input (DB25-19) has the same audio characteristics as the Front Panel Mic Jack. External Mod Input (DB25-7) has no pre-emphasis or modulation limiting.

External Speaker – 19A149590P11

The external speaker kit includes a 4-ohm, 10 Watt rated speaker and a radio option cable. To connect an external speaker, the radio option cable (RPM 113 7674/1) must be installed and connected to the radio.

1. Mount the speaker so it is directed at the operator but does not interfere with the operator's vision. It also should not present a hazard in the event of an accident. The speaker may be mounted on the lower edge of the instrument panel, the firewall, or above the windshield in some trucks.
2. Use the mounting bracket as a template for locating the mounting holes, and mount the speaker as shown in Figure 10.
3. Refer to Figure 9 for instructions on connecting the External Speaker option and Figure 10 for instructions on connecting the Internal/External Speaker option.

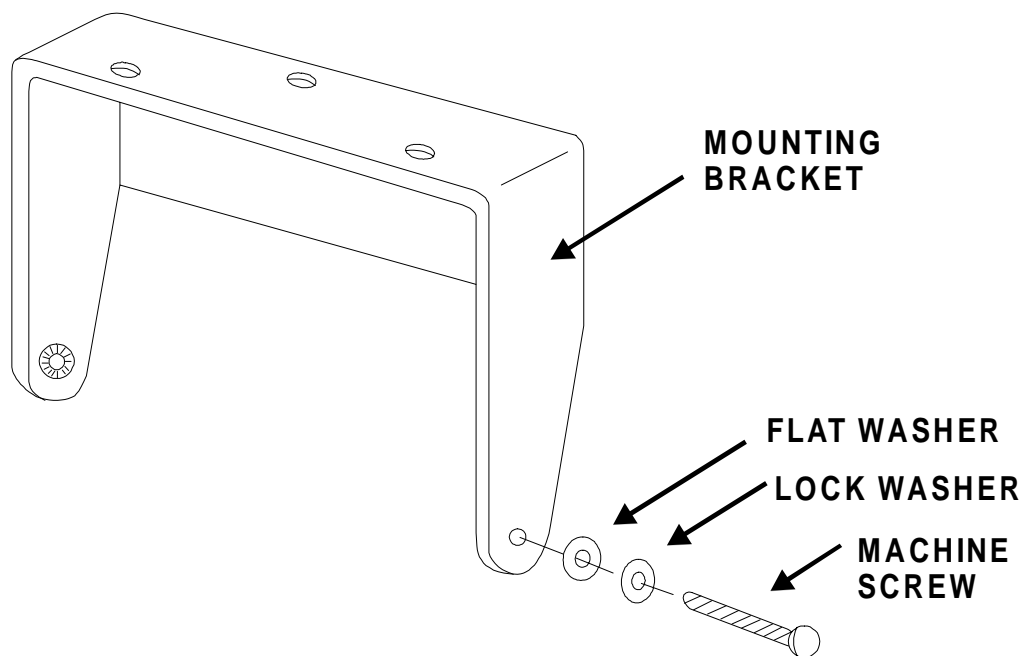
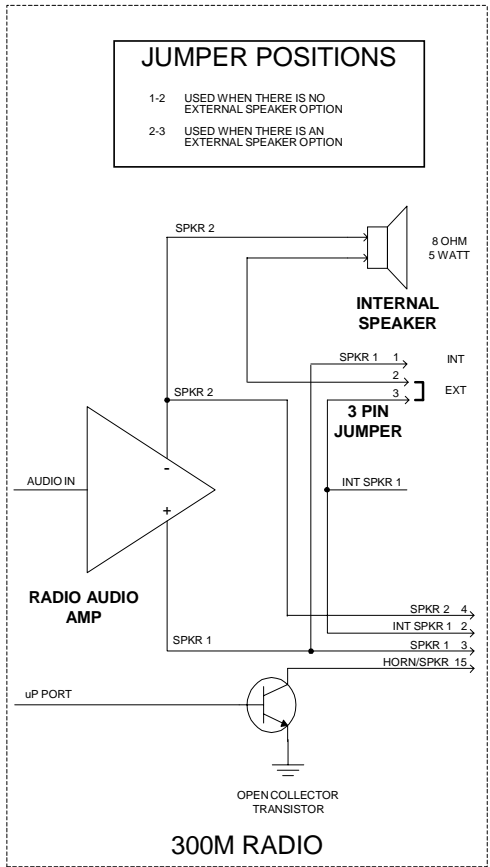

Figure 10 - Mounting the External Speaker



PANTHER 300M EXTERNAL SPEAKER OPTION

WHEN THE EXTERNAL SPEAKER OPTION IS APPLIED, AUDIO FROM THE SPEAKER AMP LEAVES THE RADIO ON OPTION CONNECTOR PINS 3 AND 4 AND GOES TO J101. THE EXTERNAL SPEAKER'S CABLE IS CONNECTED TO J101.

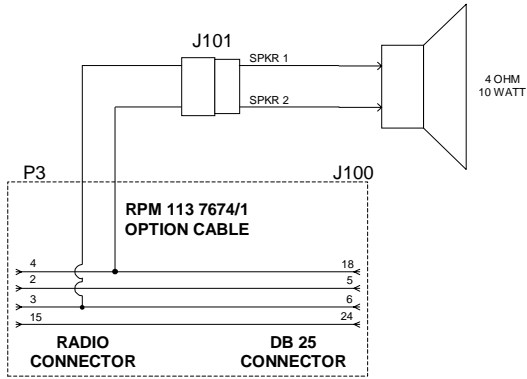
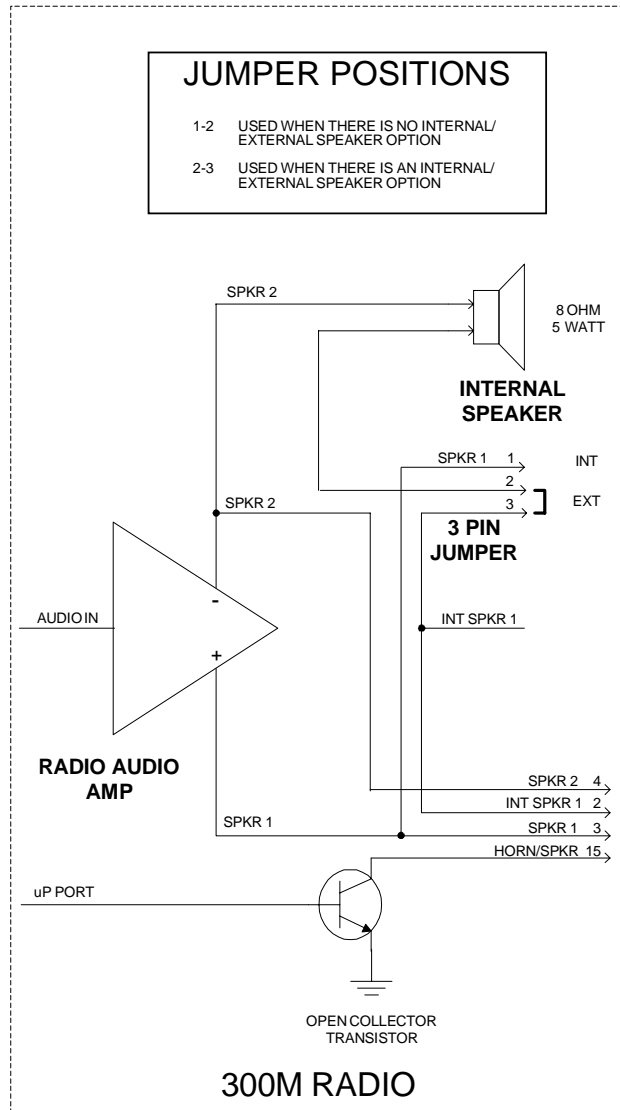

Figure 11 – External Speaker Option

Figure 12 – Internal/External Speaker Relay



PANTHER 300M INTERNAL/EXTERNAL SPEAKER OPTION

(THIS SCHEMATIC ALSO APPLIES TO PUBLIC ADDRESS)

WHEN THE INTERNAL/EXTERNAL SPEAKER OR PUBLIC ADDRESS OPTIONS ARE APPLIED. AUDIO FROM THE SPEAKER AMP LEAVES THE RADIO ON OPTION CONNECTOR PIN 3 AND GOES TO THE COMMON SIDE OF AN SPDT RELAY.

WHEN INTERNAL SPEAKER IS SELECTED, THE RELAY FLOATS. THE NORMALLY CLOSED RELAY CONTACT APPLIES AUDIO BACK INTO THE RADIO TO THE INTERNAL SPEAKER ON OPTION CONNECTOR PIN 2. (IT IS ASSUMED THE INTERNAL 3-PIN JUMPER IS ON PINS 2 & 3.)

WHEN THE EXTERNAL SPEAKER IS SELECTED, THE RELAY IS ENGAGED. AUDIO IS APPLIED TO THE NORMALLY OPEN CONTACT THAT THEN CONNECTS TO THE EXTERNAL SPEAKER.

ONLY THE SPKR_1 SIDE OF THE AUDIO AMP'S OUTPUT IS SWITCHED. THE SPKR_2 SIDE OF THE AUDIO AMP IS CONNECTED TO BOTH SPEAKERS.

OUR SPEAKER RELAY KIT INCLUDES THE 19A149299P1 RELAY, WIRE, AND A FUSE. THE CUSTOMER IS RESPONSIBLE FOR INSTALLING AND PROVIDING POWER TO THE RELAY.

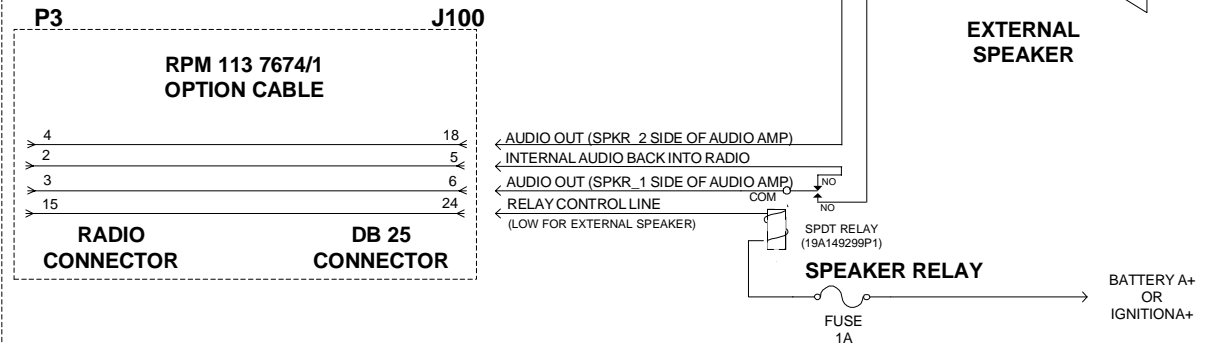

Alarm (Horn) Relay Kit - 19A705499P1

To connect the alarm relay kit, the radio option cable (RPM 113 7674/1) must be installed and connected to the radio. The alarm relay kit option consists of the following items:

- Relay (19A149299P1)
- Fuse holder
- Fuse, 1 amp, 250 volt
- 4 feet red wire, AWG #18 with Ring Tongue Terminal for 3/ 8 stud
- 6 feet black wire, AWG #18 with Molex #39- 00- 0060 terminal
- (5) Insulated 1/ 4 inch spade tab receptacles
- Ring Tongue Terminal for 3/ 8 inch stud
- #8 x 3/ 4 long Type A sheet metal screw
- Nut Plate for #8 screw

To install the Alarm (Horn) Relay Kit

1. Fasten the relay in the desired location, close to the voltage source, using one #8 x 3/ 4 inch self- tapping screw.
2. Crimp an insulated 1/ 4 inch spade tab receptacle to one end of the #18 red wire.
3. Connect the receptacle to relay lug #86. Cut the red lead so the fuse assembly is close to the voltage source. Install the fuse holder. Attach the other end of the fuse lead to the voltage source with appropriate hardware. See Figure 14.
4. From the radio option cable, take the green/white wire and crimp an insulated 1/ 4 inch spade tab receptacle. Connect the receptacle to relay lug #85.
5. Connect the horn or light circuit to lugs #30 and #87 (not 87a) using the insulated 1/ 4 inch spade tab receptacles.



The relay contact make/break current and voltage rating is 30 amps at 16 volts.

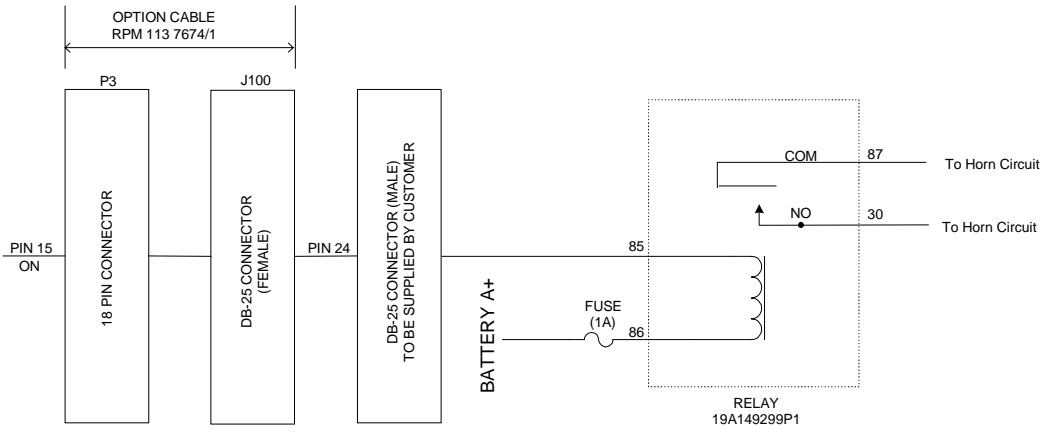

Figure 13 - External Car Alert

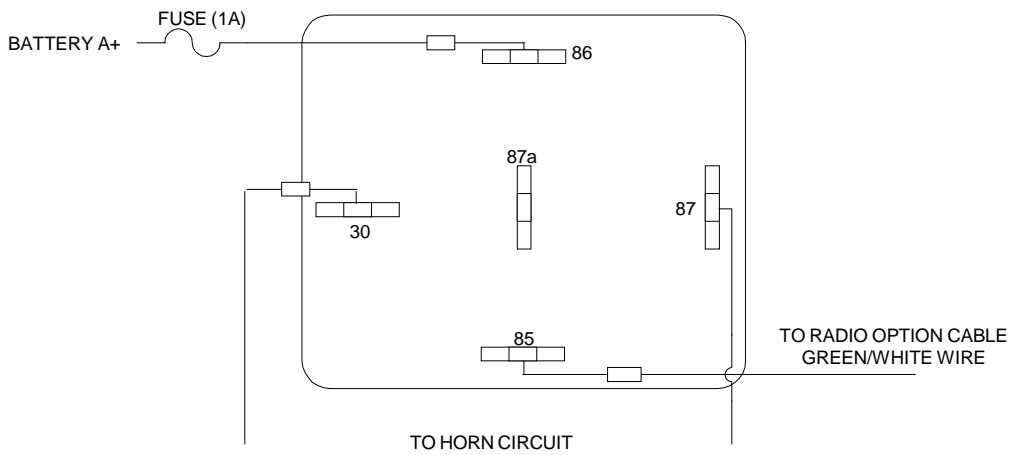

Figure 14 - External Alarm Relay

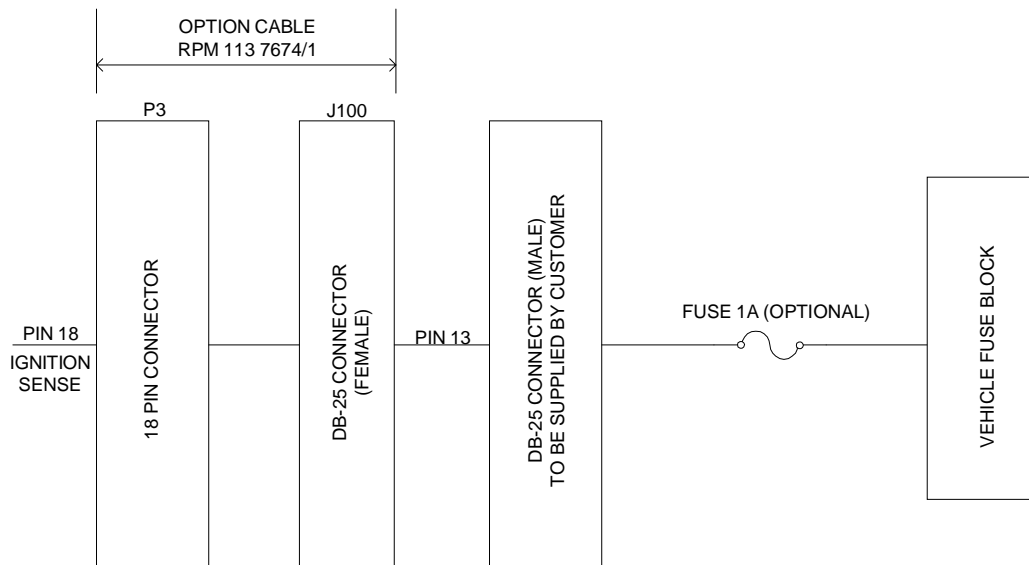

Figure 15 – Ignition Sense Option

Microphone Hanger/Hook Switch Mounting – 344A4678P1

The microphone hanger or Hook Switch should be mounted in a location convenient to the operator where it will not interfere with the safe operation of the vehicle or be a hazard to the vehicle passengers. The hanger or hook switch is designed to mount with the open end of the mounting button slot pointed upward.

1. Use the hanger or Hook Switch as a template to mark and drill the mounting holes. Mount the hanger or hook switch with the self-tapping screws provided.
2. Connect microphone connector to connector on control unit and secure with captive screw.



NOTE

Do not torque microphone connector screw greater than 2 in-lb. Alternatively, finger tight plus 1/4 turn is acceptable.

Antenna

Installation instructions for the antenna are packaged with the antenna. The antenna must be installed in accordance with good engineering practice for optimum results.

Typical Mobile Antenna Installation

A permanent mount-type antenna should be located in the center of the roof or center of rear deck. ***Important Note: Rear deck mounting of an antenna is only applicable when the installation provides at least 25 centimeters (10 inches) between the antenna and occupants of the vehicle. This distance recommendation is made using a 50% duty cycle.***



See “Safety Training Information” section at the beginning of this manual for further information regarding Specific Absorption Rate (SAR) limits of RF radiation absorption set by the FCC.

Try to route the cable away from locations where it will be exposed to heat, sharp edges or mechanical damage, and where it will be out of the way of the driver, passengers or vehicles mechanics. Wherever possible, existing holes in the trunk wall, and the channels above or beneath doors and window columns should be utilized.

Avoid routing the antenna cable near any electronic modules or along side any vehicle wiring.

Connect the antenna cable to the TNC on the radio, being careful not to twist the cable.

Typical Desktop Base Station Antenna Installation

For desktop base station configurations, a typical building roof top/tower installation may be used.

Noise Suppression Kit - Option KMPD1A (19A148539G1)

Refer to the noise suppression kit option installation manual that is included with this option.

Com-Net Ericsson Critical Radio Systems, Inc.

P.O. Box 2000

Lynchburg, Virginia 24501

1-800-528-7711 (Outside USA, 804-239-3028)

www.com-netericsson.com

Printed in U.S.A.