

Wireless Test Report 370507-1TRFWL

370507-1TRFWL

Date of issue: August 23, 2019

Applicant:

Barrett Communications Pty Ltd

Product:

4075 HF High Power Transmitter-1000 W

Model:

BC407521

FCC ID:

OW4-BC407521

Specifications:

FCC 47 CFR Part 87

Aviation Services

Lab and test locations

Company name	Nemko Canada Inc.			
Facilities	Ottawa site: 303 River Road Ottawa, Ontario Canada K1V 1H2 Tel: +1 613 737 9680 Fax: +1 613 737 9691	Montréal site: 292 Labrosse Avenue Pointe-Claire, Québec Canada H9R 5L8 Tel: +1 514 694 2684 Fax: +1 514 694 3528	Cambridge site: 1-130 Saltsman Drive Cambridge, Ontario Canada N3E 0B2 Tel: +1 519 650 4811	Almonte site: 1500 Peter Robinson Road West Carleton, Ontario Canada K0A 1L0 Tel: +1 613 256-9117 Fax: +1 613 256-8848
Test site registration	Organization FCC/ISED	Recognition numbers and location CA2040 (Ottawa/Almonte); CA2041 (Montreal); CA0101 (Cambridge)		
Website	www.nemko.com			

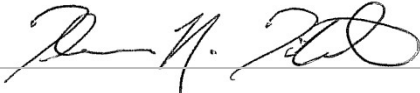
Tested by	Fahar Abdul Sukkoor, Wireless/EMC Specialist
Reviewed by	Tom Tidwell, Director Nemko Direct for Teleccom
Date	August 23, 2019
Signature	

Limits of responsibility

Note that the results contained in this report relate only to the items tested and were obtained in the period between the date of initial receipt of samples and the date of issue of the report.

This test report has been completed in accordance with the requirements of ISO/IEC 17025. All results contain in this report are within Nemko Canada's ISO/IEC 17025 accreditation.

Copyright notification

Nemko Canada Inc. authorizes the applicant to reproduce this report provided it is reproduced in its entirety and for use by the company's employees only. Any use which a third party makes of this report, or any reliance on or decisions to be made based on it, are the responsibility of such third parties. Nemko Canada Inc. accepts no responsibility for damages, if any, suffered by any third party as a result of decisions made or actions based on this report.
© Nemko Canada Inc.

Table of contents

Table of contents	3
Section 1. Report summary	4
1.1 Applicant and manufacturer	4
1.2 Test specifications	4
1.3 Test methods.....	4
1.4 Statement of compliance	4
1.5 Exclusions	4
1.6 Test report revision history	4
Section 2. Summary of test results	5
2.1 FCC Part 87 test results	5
Section 3. Equipment under test (EUT) details	6
3.1 Sample information.....	6
3.2 EUT information	6
3.3 Technical information	6
3.4 Product description and theory of operation	6
3.5 EUT exercise details.....	6
3.6 EUT setup diagram	7
3.7 EUT sub assemblies	7
Section 4. Engineering considerations	8
4.1 Modifications incorporated in the EUT.....	8
4.2 Technical judgment	8
4.3 Deviations from laboratory tests procedures.....	8
Section 5. Test conditions	9
5.1 Atmospheric conditions	9
5.2 Power supply range.....	9
Section 6. Measurement uncertainty	10
6.1 Uncertainty of measurement	10
Section 7. Test equipment	11
7.1 Test equipment list.....	11
Section 8. Testing data	12
8.1 FCC 87.131 Power and emissions	12
8.2 FCC 2.1047 Modulation characteristics	14
8.3 FCC 87.139(c) Emission limits, emission mask, bandwidth.....	17
8.4 FCC 87.141(d) Modulation requirements	20
8.5 FCC 87.139(c) Emission limits, conducted method.....	23
8.6 FCC 87.139(c) Emission limits, radiated method	26
8.7 FCC 87.133 Frequency stability	29
Section 9. Block diagrams of test set-ups	30
9.1 Radiated emissions set-up for frequencies 30 MHz- 1 GHz	30
9.2 Radiated emissions set-up for frequencies below 30 MHz.....	30
9.3 Frequency stability	31
9.4 Power limits, Modulation Characteristics, Emission limits, emission mask, bandwidth, Emission limits, conducted method	31

Section 1. Report summary

1.1 Applicant and manufacturer

Company name	Barrett Communications Pty Ltd
Address	47 Discovery Drive, Bibra Lake
City	Perth
Province/State	Western Australia
Postal/Zip code	6163
Country	Australia

1.2 Test specifications

FCC 47 CFR Part 87	Aviation Services
--------------------	-------------------

1.3 Test methods

ANSI C63.26:2015	American National Standard for Compliance Testing of Transmitters Used in Licensed Radio Services
------------------	---

1.4 Statement of compliance

In the configuration tested, the EUT was found compliant.

Testing was completed against all relevant requirements of the test standard. Results obtained indicate that the product under test complies in full with the requirements tested. The test results relate only to the items tested.

See "Summary of test results" for full details.

1.5 Exclusions

None

1.6 Test report revision history

Revision #	Details of changes made to test report
TRF	Original report issued

Section 2. Summary of test results

2.1 FCC Part 87 test results

Part	Test description	Verdict
§87.131	Power and emissions	Pass
2.1047	Modulation characteristics	Reported
87.139(c)	Emission limits, emission mask, bandwidth	Pass
87.141(d)	Modulation requirements	Pass
87.139(c)	Emission limits, conducted method	Pass
87.139(c)	Emission limits, radiated method	Pass
87.133(c)	Frequency stability	Pass

Notes: None

Section 3. Equipment under test (EUT) details

3.1 Sample information

Receipt date	May 15, 2019
Nemko sample ID number	2

3.2 EUT information

Product name	4075 HF High Power Transmitter-1000 W
Model	BC407521
Serial number	407510110

3.3 Technical information

Operating band	1.6–30 MHz
Test frequencies	2.182, 11.363, and 21.964 MHz
Modulation type	J3E and H3E
Occupied bandwidth (99 %)	2.7 kHz (J3E), 3 kHz (H3E)
Power requirements	120-240 V AC
Emission designator	2K70J3E, 3K00H3E
Antenna information	Various types with standard PL-259 connector

3.4 Product description and theory of operation

The Barrett 4075 Transmitter is a SDR based, 1000 channel HF SSB Transceiver with a frequency range of 1.6 to 30 MHz (250 kHz to 30 MHz in receive) with linear amplifier. The Barrett 4075 is designed using the latest technology including a high-resolution touch screen, IP connectivity, multi-language support, enhanced DSP noise reduction, secure digital voice, integrated GPS interface, ALE and advanced calling features.

3.5 EUT exercise details

The EUT was programmed for the low, mid, and high channels J3E used 400 and 1800 Hz input tone and H3E used 1500 Hz

3.6 EUT setup diagram

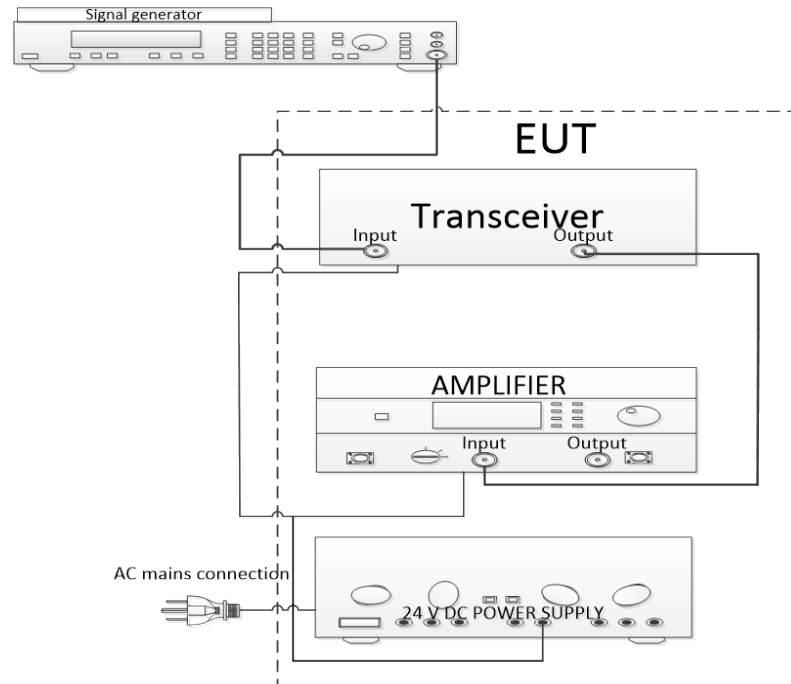

Figure 3.6-1: Setup diagram

3.7 EUT sub assemblies

Table 3.7-1: EUT sub assemblies

Description	Brand name	Model/Part number	Serial number
Linear Amplifier	Barrett	4075/BC407501	407510117
Break out box	Barrett	4050/BCA40050	405510114
24 V Power Supply/ 12.5 V 5 A charger	Barrett	4022/-	-
HF Transceiver	Barrett	4050/BC405000	405011528

Section 4. Engineering considerations

4.1 Modifications incorporated in the EUT

There were no modifications performed to the EUT during this assessment.

4.2 Technical judgment

Tested as a system not as standalone amplifier

4.3 Deviations from laboratory tests procedures

No deviations were made from laboratory procedures.

Section 5. Test conditions

5.1 Atmospheric conditions

Temperature	15–30 °C
Relative humidity	20–75 %
Air pressure	860–1060 mbar

When it is impracticable to carry out tests under these conditions, a note to this effect stating the ambient temperature and relative humidity during the tests shall be recorded and stated.

5.2 Power supply range

The normal test voltage for equipment to be connected to the mains shall be the nominal mains voltage. For the purpose of the present document, the nominal voltage shall be the declared voltage, or any of the declared voltages $\pm 5\%$, for which the equipment was designed.

Section 6. Measurement uncertainty

6.1 Uncertainty of measurement

UKAS Lab 34 and TIA-603-B have been used as guidance for measurement uncertainty reasonable estimations with regards to previous experience and validation of data. Nemko Canada, Inc. follows these test methods in order to satisfy ISO/IEC 17025 requirements for estimation of uncertainty of measurement for wireless products.

Measurement uncertainty budgets for the tests are detailed below. Measurement uncertainty calculations assume a coverage factor of $K = 2$ with 95% certainty.

Test name	Measurement uncertainty, dB
All antenna port measurements	0.55
Conducted spurious emissions	1.13
Radiated spurious emissions	3.78
AC power line conducted emissions	3.55

Section 7. Test equipment

7.1 Test equipment list

Table 7.1-1: Equipment list

Equipment	Manufacturer	Model no.	Asset no.	Cal cycle	Next cal.
Receiver/spectrum analyzer	Rohde & Schwarz	ESR 26	FA002969	1 year	Jun-01/2019
3m EMI Test chamber	TDK	SAC-3	FA003012	1 year	Aug-22/2019
Flush mount table	SUNAR	FM2022	FA003006	-	NCR
Controller	SUNAR	SC110V	FA002976	-	NCR
Antenna mast	SUNAR	TLT2	FA003007	-	NCR
Bilog Antenna(20-2000 MHz)	SUNAR	JB1	FA003009	1year	Sep-06/2019
Loop Antenna (9 kHz-30 MHz)	COM-Power	AL-130R	FA003002	1 year	Aug-08/2019
Receiver/spectrum analyzer	Rohde & Schwarz	FSW	FA002969	1 year	Jun-01/2019
Temperature chamber	Espec	EPX-4H	FA003033	-	NCR
Arbitrary Waveform Generator	HP	33120A	FA001082	-	VOU
Arbitrary Waveform Generator	GW	GAG-808G	FA001034	-	VOU

Note: NCR - no calibration required, VOU - verify on use

Section 8. Testing data

8.1 FCC 87.131 Power and emissions

8.1.1 Definitions and limits

Class of station	Frequency band/frequency	Authorized emission(s) ²	Maximum power ¹
Aeronautical enroute and aeronautical fixed	HF	R3E, H3E, J3E, J7B, H2B, J2D	6 kW

¹The power is measured at the transmitter output terminals and the type of power is determined according to the emission designator as follows:

- (i) Mean power (pY) for amplitude modulated emissions and transmitting both sidebands using unmodulated full carrier.
- (ii) Peak envelope power (pX) for all emission designators other than those referred to in paragraph (i) of this note.

²Excludes automatic link establishment.

8.1.2 Test summary

Test date	May 17, 2019	Temperature	22 °C
Test engineer	Fahar Abdul Sukkoor	Air pressure	1003 mbar
Verdict	Pass	Relative humidity	32 %

8.1.3 Observations, settings and special notes

J3E – two tones at frequencies of 400 Hz and 1800 Hz, H3E one tone at a frequency of 1500 Hz

Test receiver settings:

Detector mode	Peak
Resolution bandwidth	>OBW
Video bandwidth	>RBW
Trace mode	Max Hold
Measurement time	Auto



8.1.4 Test data

Table 8.1-1: results 1000 W system operation

Modulation	Frequency, MHz	RF output power, dBm	Limit, dBm	Margin, dB
J3E	2.182	62.44	67.78	5.34
J3E	11.363	58.36	67.78	9.42
J3E	21.964	58.48	67.78	9.30

Table 8.1-2: results 1000W system operation

Modulation	Frequency, MHz	RF output power, dBm	Limit, dBm	Margin, dB
H3E	2.182	61.16	67.78	6.62
H3E	11.363	61.58	67.78	6.20
H3E	21.964	60.97	67.78	6.81

8.2 FCC 2.1047 Modulation characteristics

8.2.1 Definitions and limits

(a) Voice modulated communication equipment. A curve or equivalent data showing the frequency response of the audio modulating circuit over a range of 100 to 5000 Hz shall be submitted. For equipment required to have an audio low-pass filter, a curve showing the frequency response of the filter, or of all circuitry installed between the modulation limiter and the modulated stage shall be submitted.

(c) Single sideband and independent sideband radiotelephone transmitters which employ a device or circuit to limit peak envelope power. A curve showing the peak envelope power output versus the modulation input voltage shall be supplied. The modulating signals shall be the same in frequency as specified in paragraph (c) of §2.1049 for the occupied bandwidth tests.

8.2.2 Test summary

Test date	May 17, 2019	Temperature	22 °C
Test engineer	Fahar Abdul Sukkoor	Air pressure	1003 mbar
Verdict	Pass	Relative humidity	32 %

8.2.3 Observations, settings and special notes

Settings and special notes

Detector mode	Peak
Resolution bandwidth	>OBW
Video bandwidth	>RBW

8.2.4 Test data

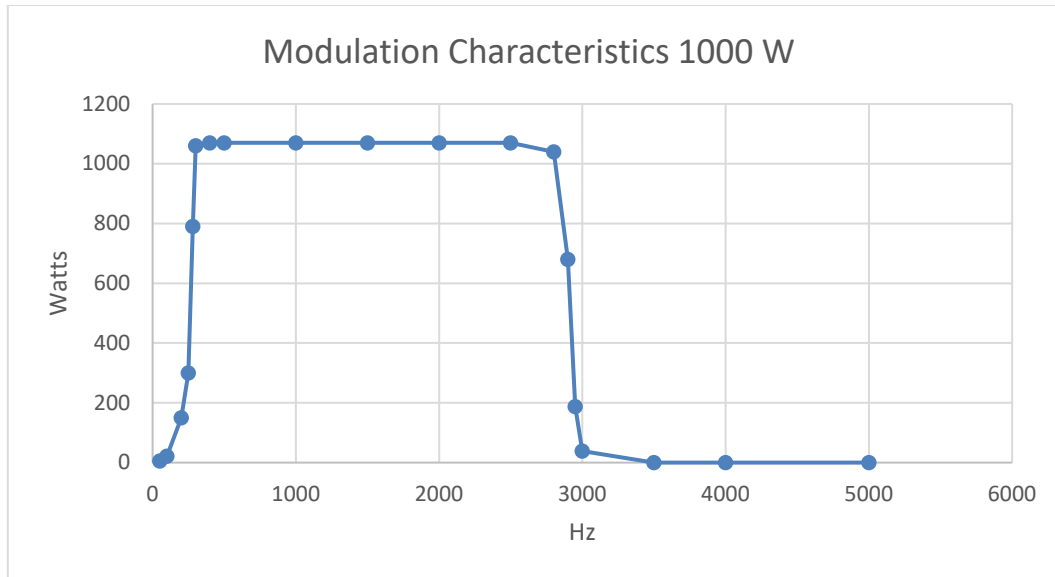

Figure 8.2-1: Modulation Characteristic 1000 Watts



Table 8.2-1: Modulation Characteristic results 1000 Watts

Hz	Watts
50	5
100	22
200	150
250	300
280	790
300	1060
500	1070
1000	1070
2000	1070
2800	1040
2900	680
2950	187
3000	39
3500	0.028
4000	0.028

Table 8.2-2: Modulation Limiting results 1000 Watts

2.182 MHz		11.363 MHz		21.964 MHz	
Input Audio,V	Output power, Watts	Input Audio,V	Output power, Watts	Input Audio,V	Output power, Watts
0.03	1	0.03	0.4	0.07	1
0.04	1.8	0.04	0.8	0.1	3
0.05	3	0.05	1.45	0.15	14
0.1	16	0.1	8	0.2	50
0.15	29	0.15	24	0.25	150
0.2	60	0.2	55	0.3	300
0.25	105	0.25	110	0.35	560
0.3	500	0.3	400	0.37	700
0.35	700	0.35	600	0.38	750
0.47	800	0.37	700	0.39	810
0.4	950	0.4	855	0.4	870
0.41	1040	0.41	1070	0.41	935
0.45	1090	0.45	1070	0.45	1040
0.5	1090	0.5	1070	0.5	1040

8.3 FCC 87.139(c) Emission limits, emission mask, bandwidth

8.3.1 Definitions and limits

(c) For aircraft station transmitters first installed after February 1, 1983, and for aeronautical station transmitters in use after February 1, 1983, and using H2B, H3E, J3E, J7B or J9W, the peak envelope power of any emissions must be attenuated below the peak envelope power of the transmitter (pX) as follows:

- 1) When the frequency is removed from the assigned frequency by more than 50 percent up to and including 150 percent of the authorized bandwidth of 3.0 kHz, the attenuation must be at least 30 dB.
- 2) When the frequency is removed from the assigned frequency by more than 150 percent up to and including 250 percent of the authorized bandwidth of 3.0 kHz, the attenuation must be at least 38 dB.
- 3) When the frequency is removed from the assigned frequency by more than 250 percent of the authorized bandwidth of 3.0 kHz for aircraft transmitters the attenuation must be at least 43 dB. For aeronautical station transmitters with transmitter power up to and including 50 watts the attenuation must be at least $43 + 10 \log_{10} pX$ dB and with transmitter power more than 50 watts the attenuation must be at least 60 dB.

8.3.2 Test summary

Test date	May 17, 2019	Temperature	22 °C
Test engineer	Fahar Abdul Sukkoor	Air pressure	1003 mbar
Verdict	Pass	Relative humidity	32 %

8.3.3 Observations, settings and special notes

Spectrum analyzer settings:

Detector mode	Peak
Resolution bandwidth	300 Hz or 30 or 20 Hz
Video bandwidth	RBW × 3
Trace mode	Max Hold

8.3.4 Test data

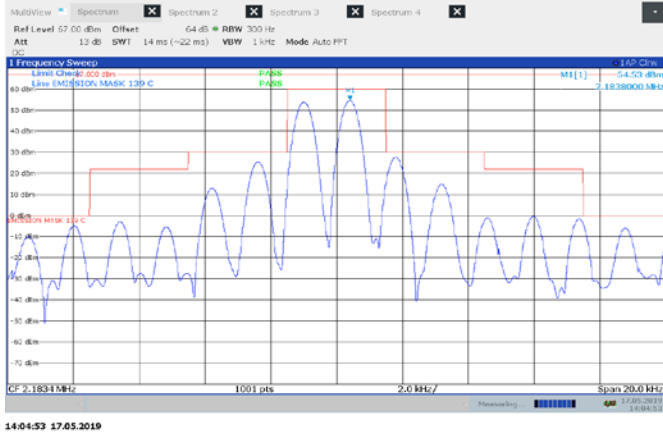

Figure 8.3-1: Low channel Mask 1000W J3E

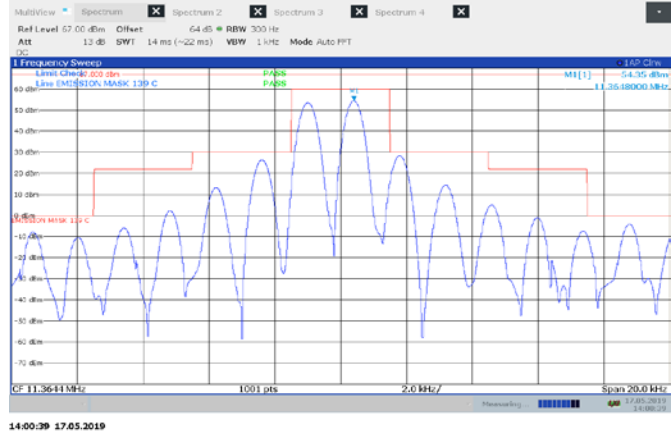

Figure 8.3-2: Mid channel Mask 1000W J3E

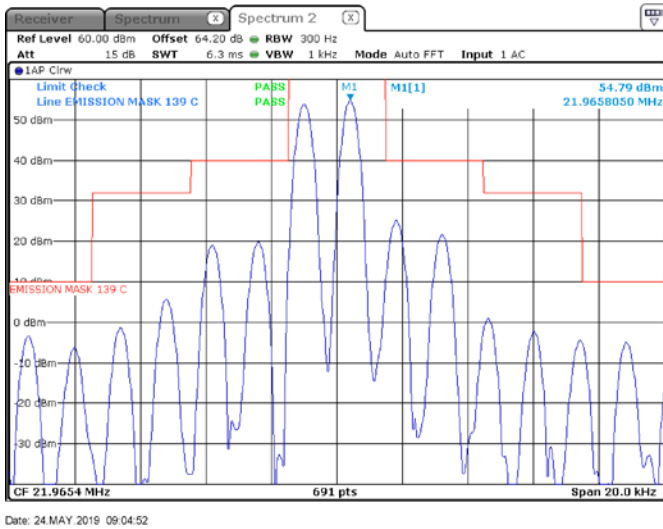

Figure 8.3-3: High channel Mask 1000W J3E

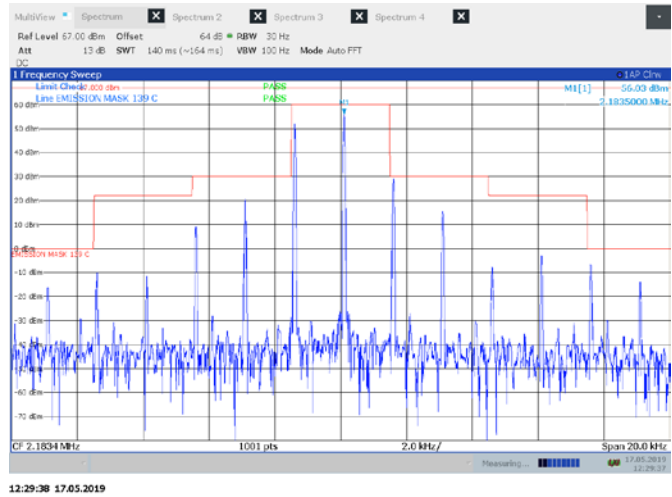

Figure 8.3-4: Low channel Mask 1000W H3E

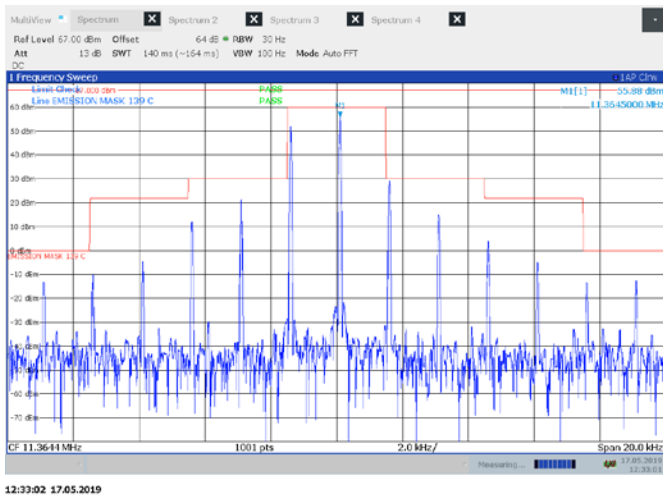

Figure 8.3-5: Mid channel Mask 1000W H3E

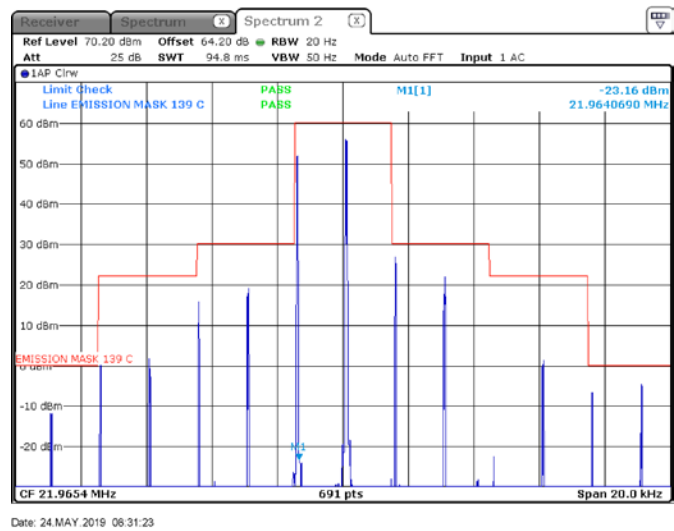

Figure 8.3-6: High channel Mask 1000W H3E

8.4 FCC 87.141(d) Modulation requirements

8.4.1 Definitions and limits

(d) Single sideband transmitters must be able to operate in the following modes:

Carrier mode	Level N(dB) of the carrier with respect to peak envelope power
Full carrier (H3E)	$0 > N > -6$
Suppressed carrier (J3E)	Aeronautical stations $N < -40$.

8.4.2 Test summary

Test date	May 17, 2019	Temperature	22 °C
Test engineer	Fahar Abdul Sukkoor	Air pressure	1003 mbar
Verdict	Pass	Relative humidity	32 %

8.4.3 Observations, settings and special notes

Spectrum analyzer settings:

Detector mode	Peak
Resolution bandwidth	30 Hz
Video bandwidth	RBW × 3
Trace mode	Max Hold

8.4.4 Test data

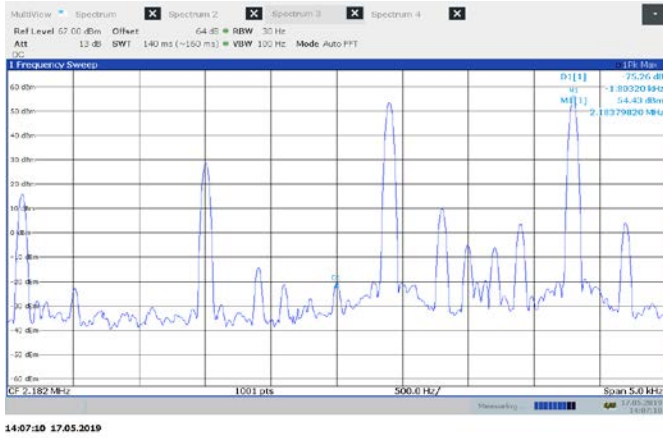

Figure 8.4-1: Low channel 1000W J3E 40 dB

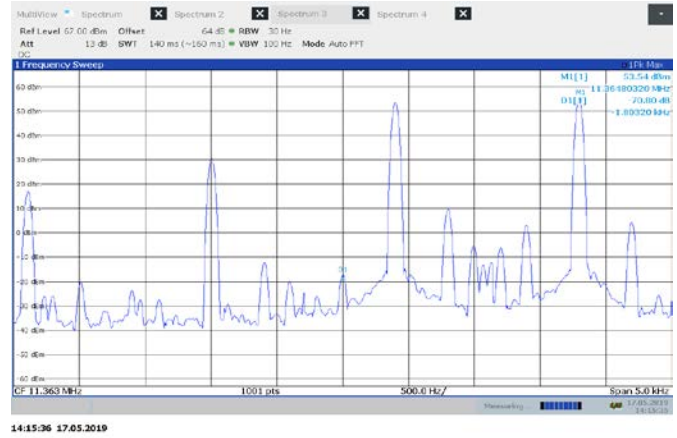

Figure 8.4-2: Mid channel 1000W J3E 40 dB

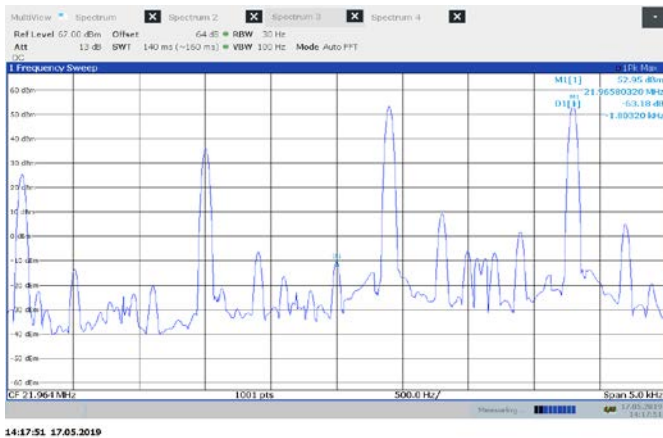

Figure 8.4-3: High channel 1000W J3E 40 dB

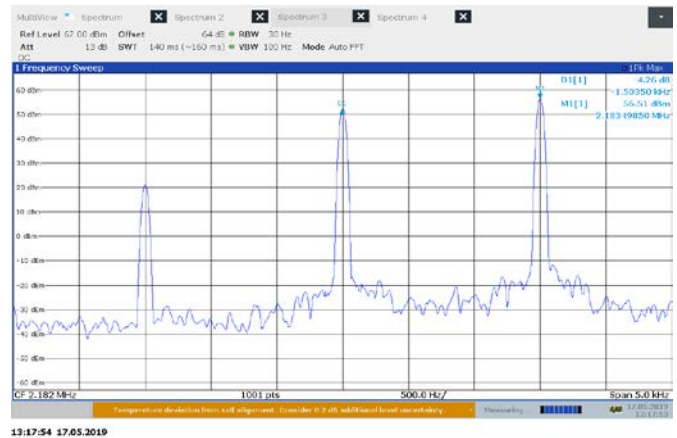

Figure 8.4-4: Low channel 1000W H3E 6 dB

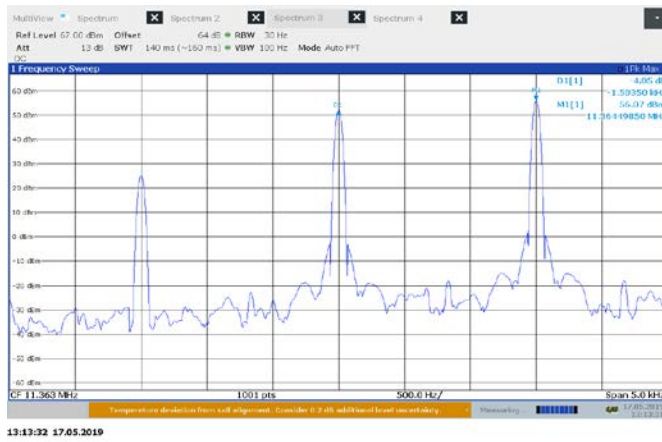

Figure 8.4-5: Mid channel 1000W H3E 6 dB

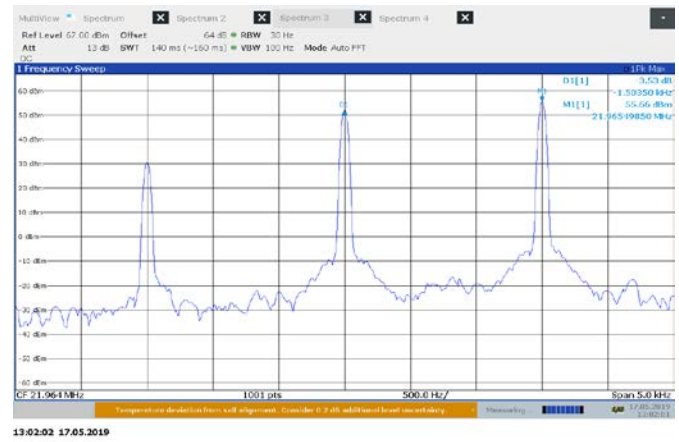

Figure 8.4-6: High channel 1000W H3E 6 dB

8.5 FCC 87.139(c) Emission limits, conducted method

8.5.1 Definitions and limits

(c) For aircraft station transmitters first installed after February 1, 1983, and for aeronautical station transmitters in use after February 1, 1983, and using H2B, H3E, J3E, J7B or J9W, the peak envelope power of any emissions must be attenuated below the peak envelope power of the transmitter (pX) as follows:

- 4) When the frequency is removed from the assigned frequency by more than 50 percent up to and including 150 percent of the authorized bandwidth of 3.0 kHz, the attenuation must be at least 30 dB.
- 5) When the frequency is removed from the assigned frequency by more than 150 percent up to and including 250 percent of the authorized bandwidth of 3.0 kHz, the attenuation must be at least 38 dB.
- 6) When the frequency is removed from the assigned frequency by more than 250 percent of the authorized bandwidth of 3.0 kHz for aircraft transmitters the attenuation must be at least 43 dB. For aeronautical station transmitters with transmitter power up to and including 50 watts the attenuation must be at least $43 + 10 \log_{10} pX$ dB and with transmitter power more than 50 watts the attenuation must be at least 60 dB.

8.5.2 Test summary

Test date	May 17, 2019	Temperature	22 °C
Test engineer	Fahar Abdul Sukkoor	Air pressure	1003 mbar
Verdict	Pass	Relative humidity	32 %

8.5.3 Observations, settings and special notes

Spectrum analyzer settings:

Detector mode	Peak
Resolution bandwidth	10 kHz
Video bandwidth	RBW × 3
Trace mode	Max Hold

8.5.4 Test data

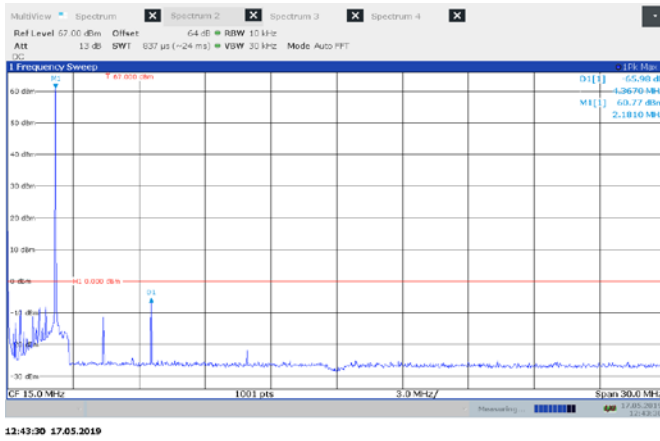

Figure 8.5-1: Low channel Conducted Spurious 1000W H3E

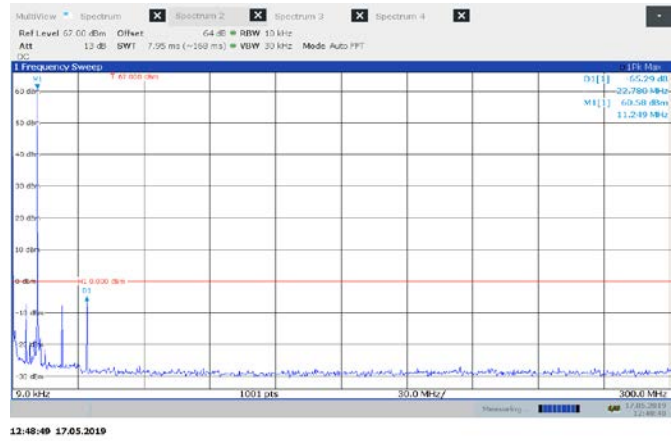

Figure 8.5-2: Mid channel Conducted Spurious 1000W H3E

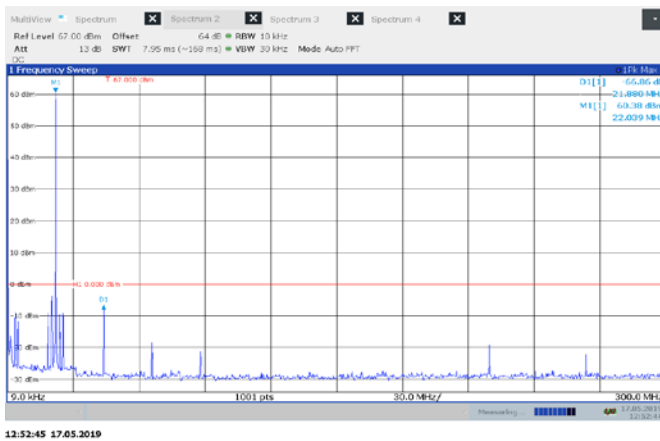

Figure 8.5-3: High channel Conducted Spurious 1000W H3E

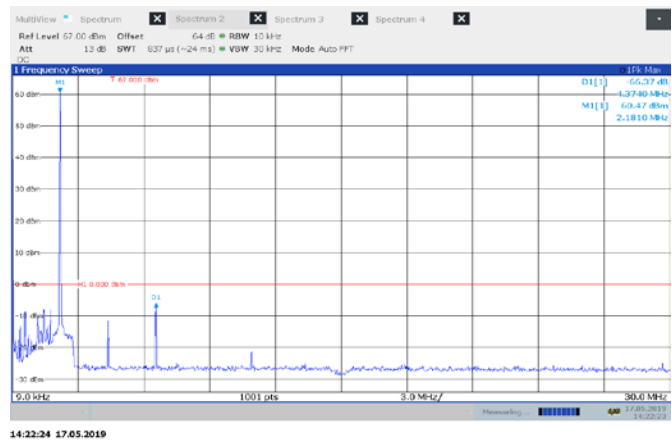

Figure 8.5-4: Low channel Conducted Spurious 1000W J3E

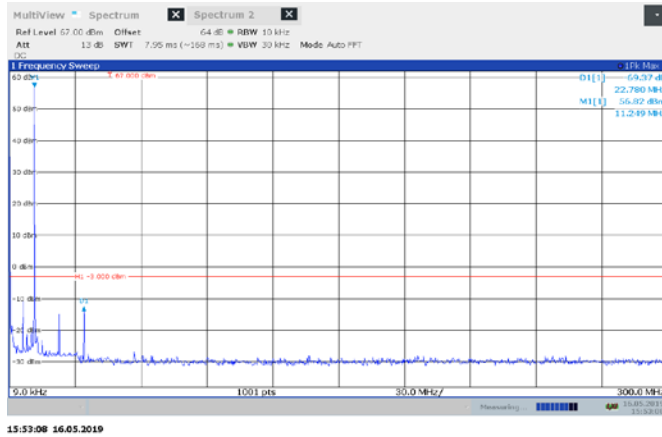

Figure 8.5-5: Mid channel Conducted Spurious 100W J3E

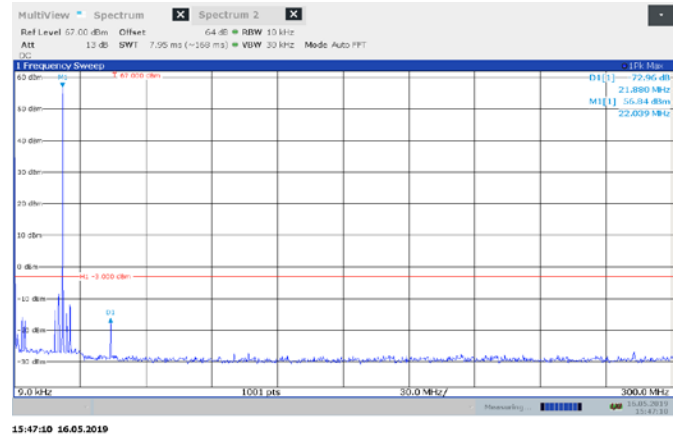

Figure 8.5-6: High channel Conducted Spurious 100W J3E

8.6 FCC 87.139(c) Emission limits, radiated method

8.6.1 Definitions and limits

- (1) When the frequency is removed from the assigned frequency by more than 50 percent up to and including 150 percent of the authorized bandwidth of 3.0 kHz, the attenuation must be at least 30 dB.
- (2) When the frequency is removed from the assigned frequency by more than 150 percent up to and including 250 percent of the authorized bandwidth of 3.0 kHz, the attenuation must be at least 38 dB.
- (c) For aircraft station transmitters first installed after February 1, 1983, and for aeronautical station transmitters in use after February 1, 1983, and using H2B, H3E, J3E, J7B or J9W, the peak envelope power of any emissions must be attenuated below the peak envelope power of the transmitter (pX) as follows:
- (3) When the frequency is removed from the assigned frequency by more than 250 percent of the authorized bandwidth of 3.0 kHz for aircraft transmitters the attenuation must be at least 43 dB. For aeronautical station transmitters with transmitter power up to and including 50 watts the attenuation must be at least $43 + 10 \log_{10} pX$ dB and with transmitter power more than 50 watts the attenuation must be at least 60 dB.

8.6.2 Test summary

Test date	May 21, 2019	Temperature	22 °C
Test engineer	Fahar Abdul Sukkoor	Air pressure	1003 mbar
Verdict	Pass	Relative humidity	32 %

8.6.3 Observations, settings and special notes

Spectrum analyzer settings:

Detector mode	Peak
Resolution bandwidth	10 kHz
Video bandwidth	RBW × 3
Trace mode	Max Hold

J3E 400 Hz and 1800 Hz tone was used during testing

8.6.4 Test data

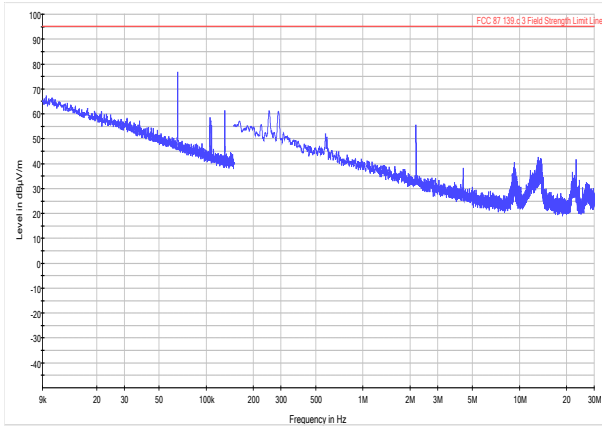

low channel 1000 W 9 kHz-30 MHz spurious emission
 PK+ MAXH
 FCC 87.139.c.3 Field Strength Limit Line

Figure 8.6-1: Low channel Radiated Spurious 1000W 9 kHz-30 MHz

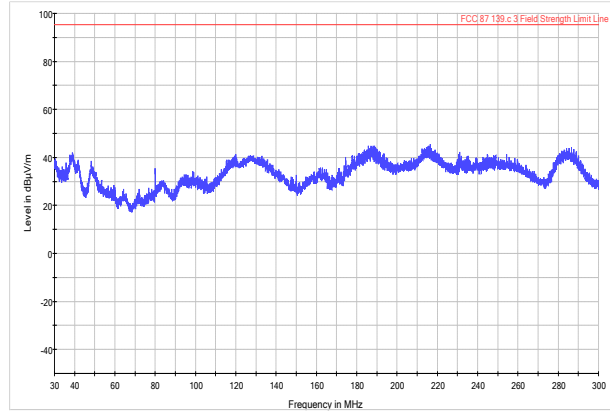

Low channel 1000 W 400 Hz and 1800 Hz
 PK+ MAXH [Result Table Result:1]
 FCC 87.139.c.3 Field Strength Limit Line [..EMI Radiated/Wireless Limits]

Figure 8.6-2: Low channel Radiated Spurious 1000W 30-300 MHz

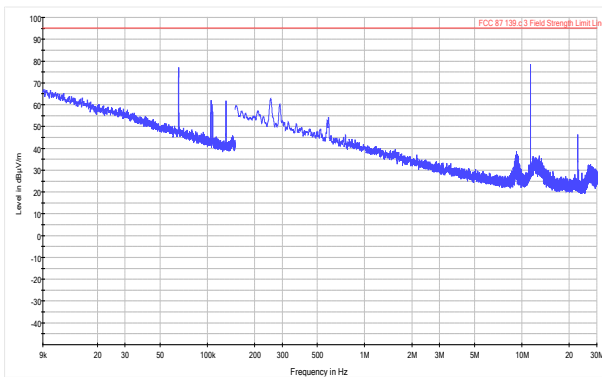

mid channel 1000 W 9 kHz-30 MHz spurious emission
 PK+ MAXH
 FCC 87.139.c.3 Field Strength Limit Line

Figure 8.6-3: Mid channel Radiated Spurious 1000W 9 kHz-30 MHz

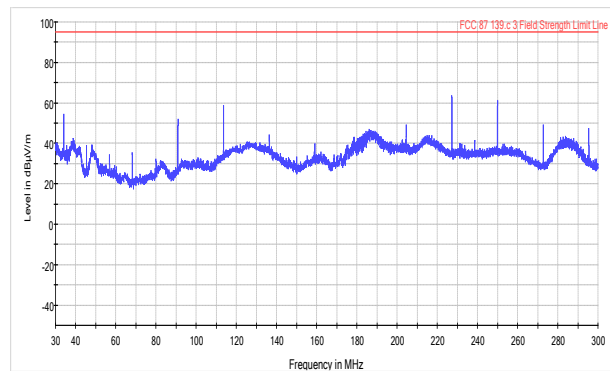

Mid channel 1000 W 400 Hz and 1800 Hz
 PK+ MAXH
 FCC 87.139.c.3 Field Strength Limit Line

Figure 8.6-4: Mid channel Radiated Spurious 1000W 30-300 MHz

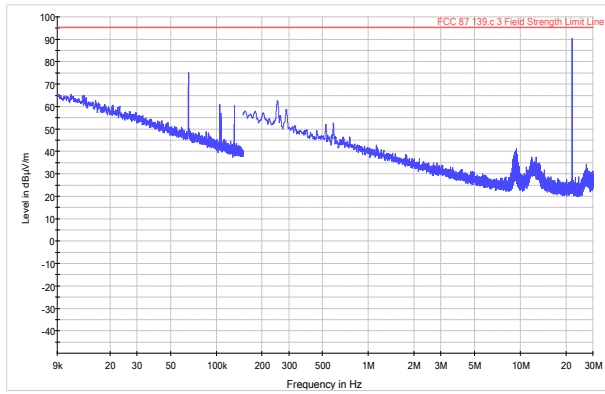

high channel 1000 W 9 kHz-30 MHz spurious emission
 PK+ MAXH
 FCC 87.139.c.3 Field Strength Limit Line

Figure 8.6-5: High channel Radiated Spurious 1000W 9 kHz-30 MHz

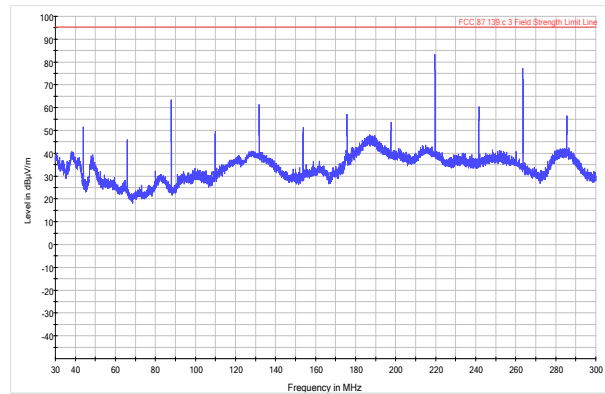

High channel 1000 W 400 Hz and 1800 Hz
 PK+ MAXH
 FCC 87.139.c.3 Field Strength Limit Line

Figure 8.6-6: High channel Radiated Spurious 1000W 30-300 MHz

8.7 FCC 87.133 Frequency stability

8.7.1 Definitions and limits

(c) For single-sideband transmitters, the tolerance is:
 (1) All aeronautical stations on land: 10 Hz.

8.7.2 Test summary

Test date	February 21, 2017	Temperature	22 °C
Test engineer	Kevin Rose	Air pressure	1003 mbar
Verdict	Pass	Relative humidity	32 %

8.7.3 Observations, settings and special notes

1500 Hz tone was used during testing

8.7.4 Test data

Table 8.7-1: Frequency drift measurement FCC Part 87 results 1000 watts

Test conditions	Frequency, Hz	Drift, Hz	Limit ±10 Hz
+50 °C, Nominal	11362999	-1	±10 Hz
+40 °C, Nominal	11363000	0	±10 Hz
+30 °C, Nominal	11363000	0	±10 Hz
+20 °C, +15 %	11363001	+1	±10 Hz
+20 °C, Nominal	11363000	-	Reference
+20 °C, -15 %	11363001	+1	±10 Hz
+10 °C, Nominal	11363002	+2	±10 Hz
0 °C, Nominal	11363002	+2	±10 Hz
-10 °C, Nominal	11363002	+2	±10 Hz
-20 °C, Nominal	11363003	+3	±10 Hz
-30 °C, Nominal	11363003	+3	±10 Hz

Section 9. Block diagrams of test set-ups

9.1 Radiated emissions set-up for frequencies 30 MHz- 1 GHz

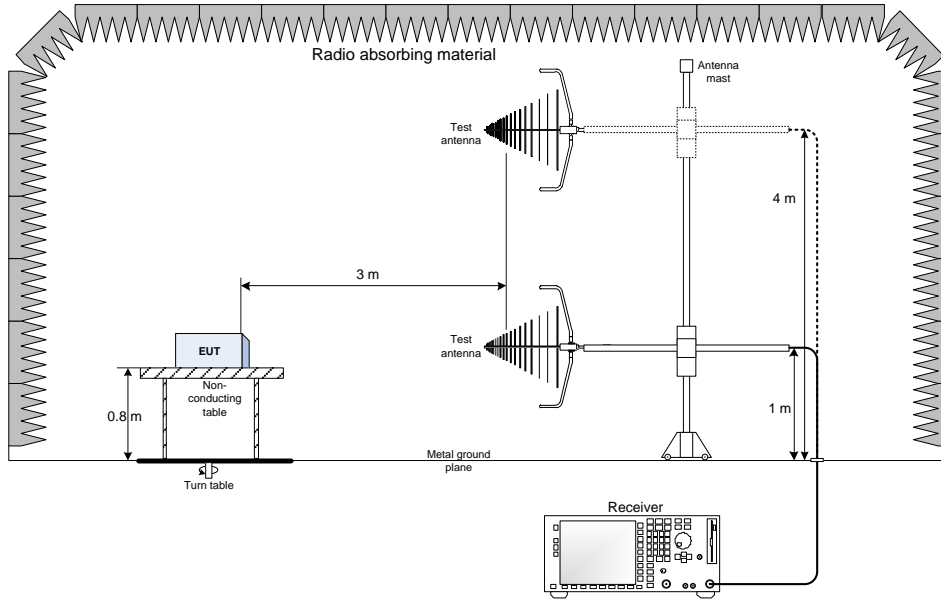

9.2 Radiated emissions set-up for frequencies below 30 MHz

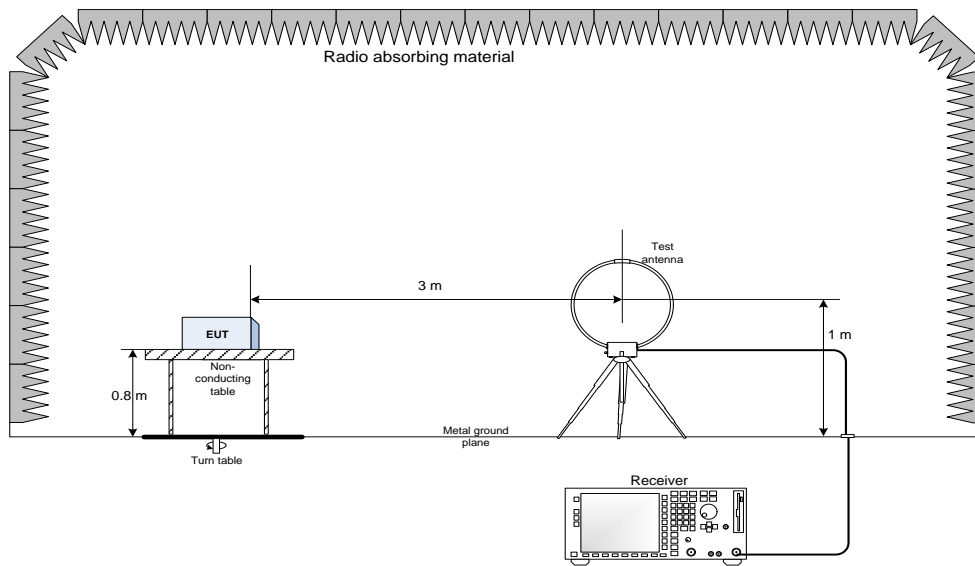

9.3 Frequency stability

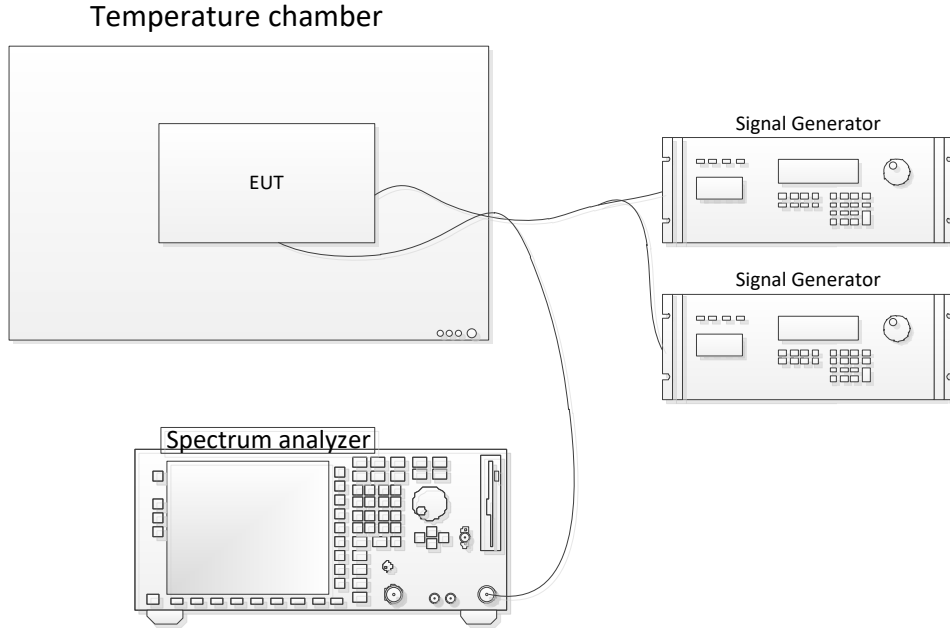

9.4 Power limits, Modulation Characteristics, Emission limits, emission mask, bandwidth, Emission limits, conducted method

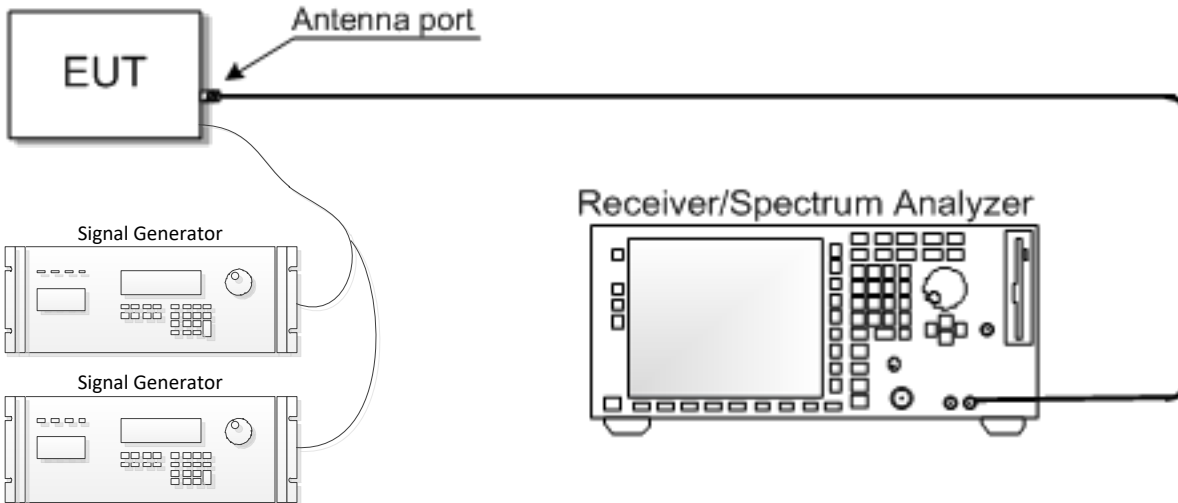

-End of test report-