

# Hearing Aid Compatibility

## FCC 47 CFR section 20.19 Test Report

|  |                    |
|--|--------------------|
| <b>Single-Band Single-Mode CDMA Cellular Phone</b> |                    |
| FCC ID:  | <b>OVFKWC-KX9D</b> |
| Model:   | <b>KX9D</b>        |

|  |   |                 |                 |
|--|---|-----------------|-----------------|
| <b>STATEMENT OF CERTIFICATION</b>  |   |                 |                 |
| <p><i>The data, data evaluation and equipment configuration represented herein are a true and accurate representation of the measurements of the sample's HAC RF emissions characteristics as of the dates and at the times of the test under the conditions herein specified.</i></p> |   |                 |                 |
| <b>STATEMENT OF COMPLIANCE</b>   |   |                 |                 |
| <p><i>This product was tested in accordance with the measurement procedures specified in ANSI PC63.19-2005 and has been shown to be capable of compliance with the technical requirements of FCC 47 CFR section 20.19.</i></p>   |   |                 |                 |
| Test Location:   | Kyocera Wireless Corp.<br>10300 Campus Point Drive, San Diego, CA 92121 USA |                 |                 |
| Test performed by:   | Thuy To<br>Regulatory Engineer  | Date of Test:   | 5/8/06 –5/12/06 |
| Report Prepared by:  | Thuy To<br>Regulatory Engineer  | Date of Report: | 5/12/06         |
| Report Reviewed by:  | C. K. Li<br>Hardware Engineer,<br>Senior Staff/Manager                      | Date of Review: | 5/16/06         |

## TABLE OF CONTENTS

|        |   |    |
|--------|---|----|
| 1      | Introduction .....                                    | 3  |
| 2      | Equipment Under Test (EUT) .....                      | 3  |
| 3      | Summary of Test Results .....                         | 3  |
| 4      | Test conditions.....                                  | 4  |
| 4.1    | Ambient Conditions .....                              | 4  |
| 4.2    | RF characteristics of the test site .....             | 4  |
| 4.3    | Test Signal, Frequencies and Output Power .....       | 4  |
| 4.4    | EUT Operating Conditions.....                         | 5  |
| 5      | Description of the test equipment.....                | 5  |
| 5.1    | Test Equipment Used .....                             | 5  |
| 5.2    | Near Field Measurement System.....                    | 6  |
| 5.3    | Isotropic E-Field Probe .....                         | 6  |
| 5.4    | Isotropic H-Field Probe.....                          | 7  |
| 6      | System Validation .....                               | 8  |
| 7      | Description Of The Test Procedure .....               | 9  |
| 7.1    | Test Positions .....                                  | 9  |
| 7.2    | RF Emission Measurements Reference and Plane .....    | 9  |
| 7.3    | RF Emissions Measurement Procedures.....              | 10 |
| 7.4    | Probe Modulation Factor (PMF).....                    | 11 |
| 7.4.1  | Measurement Procedures.....                           | 11 |
| 7.4.2  | PMF Test Results.....                                 | 12 |
| 7.4.3  | PMF Peak Power Measurement Plots .....                | 12 |
| 8      | Emission Data Extraction and Post processing.....     | 14 |
| 9      | Measurement Uncertainty.....                          | 15 |
| 10     | RF Emissions Tests .....                              | 16 |
| 10.1   | Emission Limits.....                                  | 16 |
| 10.2   | CDMA 1900 Test Results .....                          | 17 |
| 10.3   | Worst-Case Configuration Evaluation .....             | 18 |
| 10.3.1 | Peak Reading 360° Probe Rotation at Azimuth axis..... | 18 |
| 11     | Test setup photos .....                               | 19 |
|        | Appendix A: Probe Calibration Certification.....      | 20 |
|        | Appendix B: System Validation Data .....              | 22 |
|        | Appendix C: Test Results/Plots .....                  | 23 |

### 1 Introduction

This test report describes the Hearing Aid Compatibility (HAC) measurement of a wireless portable device manufactured by Kyocera Wireless Corp. (KWC). These measurements were performed for compliance with the rules and regulations of the U.S. Federal Communications Commission (FCC). The testing was performed in accordance with ANSI PC63.19-2005.

This report covers test and data on:

|          |              |                       |
|----------|--------------|-----------------------|
| <b>X</b> | RF Emissions | ANSI PC63.19 Clause 4 |
|          | T-Coil       | ANSI PC63.19 Clause 6 |

### 2 Equipment Under Test (EUT)

|  |   |
|--|---|
| <b>Product:</b>                              | Single-Band Single-mode CDMA Cellular Phone       |
| <b>FCC ID:</b>                               | OVFKWC-KX9D                                       |
| <b>Model Number:</b>                         | KX9D  |
| <b>EUT Serial Number:</b>                    | F0000006207458                                    |
| <b>Type:</b>                                 | [ ] Prototype, [X] Pre-Production, [ ] Production |
| <b>Device Category:</b>                      | Portable  |
| <b>RF Exposure Environment:</b>              | General Population / Uncontrolled                 |
| <b>Antenna:</b>                              | Stubby  |
| <b>Detachable Antenna:</b>                   | No  |
| <b>External Input:</b>                       | Audio/Digital Data                                |
| <b>Quantity:</b>                             | Quantity production is planned                    |
| <b>Modes:</b>                                | 1900 CDMA   |
| <b>Multiple Access Scheme:</b>               | CDMA  |
| <b>TX Frequency (MHz):</b>                   | 1850 - 1910                                       |
| <b>Rated RF Conducted Output Power (dBm)</b> | 23.0 Phone Open                                   |

### 3 Summary of Test Results

| <b>ANSI PC63.19 (2005)</b> |              |                  |
|----------------------------|--------------|------------------|
| Section 4 RF Emissions     |              |                  |
| Test                       | Test Results | Overall Category |
| E-Field Emissions          | M4           | <b>M4</b>        |
| H-Field Emissions          | M4           |                  |

**4 Test conditions**

**4.1 Ambient Conditions**

All tests were performed under the following environmental conditions:

|  |                        |
|--|------------------------|
| <b>Ambient Temperature:</b>                  | 23 ± 2 Degrees C       |
| <b>Tissue simulating liquid temperature:</b> | 22 ± 1 Degrees C       |
| <b>Relative Humidity (RH):</b>               | 0% <RH < 80%           |
| <b>Atmospheric Pressure:</b>                 | 101.3kPa + 10 to -5kPa |

**4.2 RF characteristics of the test site**

All HAC measurements were performed inside a shielded room that provide isolation from external EM fields, with the RF ambient at least 20 dB below the intended measurement limits.

**4.3 Test Signal, Frequencies and Output Power**

Peak and Average conducted power were measured for each mode for comparison. RC3 SO55 was chosen for worst case power configuration.

| <b>CONDUCTED POWER</b> |                           |                      |
|------------------------|---------------------------|----------------------|
| <b>Mode</b>            | <b>CDMA 1900 (ch 600)</b> |                      |
|                        | <b>Peak (dBm)</b>         | <b>Average (dBm)</b> |
| RC1, SO2, Full Rate    | 27.76                     | 22.52                |
| RC1, SO55, Full Rate   | 27.83                     | 22.59                |
| RC2, SO9, Full Rate    | 27.97                     | 22.62                |
| RC2, SO55, Full Rate   | 27.70                     | 22.57                |
| RC3, SO2, Full Rate    | 27.45                     | 22.52                |
| RC3, SO55, Full Rate   | 27.79                     | 22.60                |
| RC43, SO2, Full Rate   | 27.25                     | 22.57                |
| RC43, SO55, Full Rate  | 27.36                     | 22.57                |
| RC54, SO9, Full Rate   | 27.36                     | 22.55                |
| RC54, SO55, Full Rate  | 27.27                     | 22.58                |

During tests, the EUT was put in in-call mode and controlled by a CDMA simulator to generate the required signal and power using the configuration below.

|                             |             |
|-----------------------------|-------------|
| <b>Protocol:</b>            | 6 (IS-2000) |
| <b>Radio Configuration:</b> | 3           |
| <b>Power Control:</b>       | All Up Bits |
| <b>Service Option:</b>      | 55          |
| <b>Data Rate:</b>           | Full        |

In all operating modes, the phone was set to rated maximum RF power level and the measurements were performed on low, mid and high channels.

The measurement system measures power drift during HAC testing by comparing E/H-field in the same location at the beginning and at the end of measurement. These records were used to monitor stability of power output during tests. Conducted RF power measurements were also performed before and after each HAC measurements to confirm the output power.

**4.4 EUT Operating Conditions**

The EUT was tested with the following configurations and conditions, if applicable:

|                                     |  |
|-------------------------------------|--|
| <input checked="" type="checkbox"/> | Fully charged standard and extended battery as supplied with the handset |
| <input checked="" type="checkbox"/> | Open configuration, at ear use position.                                 |
| <input type="checkbox"/>            | Both retracted and extended antenna positions                            |
| <input checked="" type="checkbox"/> | Back-light tested ON and OFF   |

**5 Description of the test equipment**

**5.1 Test Equipment Used**

Below is a list of the calibrated equipment used for the measurements:

| Description                | Manufacturer    | Model Number | Serial Number | Cal Due Date |
|----------------------------|-----------------|--------------|---------------|--------------|
| Power Meter                | Giga-tronics    | 8541C        | 1830971       | 05/27/06     |
| Signal Generator           | Hewlett Packard | E4421B       | US38440337    | 06/20/07     |
| Radio Communication Tester | Agilent         | 8960         | US41070147    | 05/16/06     |
| Data Acq                   | Speag           | DAE4         | 530           | 01/16/07     |
| E-field Probe              | Speag           | ER3DV6       | 2282          | 10/21/06     |
| H-field Probe              | Speag           | H3DV5        | 6029          | 06/16/06     |
| Dipole Antenna (1880MHz)   | Speag           | CD1880V3     | 1015          | 04/05/07     |
| Spectrum Analyzer          | Hewlett Packard | 8594E        | 3543H02438    | 04/13/07     |

*The calibration certificates of E-field and H-field probes are attached in Appendix A.*

## 5.2 Near Field Measurement System

The measurements were performed with Dasy4 automated near-field scanning system comprised of high precision robot, robot controller, computer, near-field probe, probe alignment sensor, non-conductive phone positioner, Test Arch and software extension. The overall expanded uncertainty (K=2) of the measurement system is  $\pm 10.9\%$  and  $\pm 14.7\%$  for H-field and E-field resp. The measurement uncertainty budget is given in section 6.

## 5.3 Isotropic E-Field Probe

|                      |   |
|----------------------|---|
| <b>Model</b>         | <ul style="list-style-type: none"> <li>▪ ER3DV6</li> </ul>  |
| <b>Construction</b>  | <ul style="list-style-type: none"> <li>▪ One dipole parallel, two dipoles normal to probe axis</li> <li>▪ Built-in shielding against static charges</li> <li>▪ PEEK enclosure material (resistant to organic solvents, e.g., glycoether)</li> </ul> |
| <b>Calibration</b>   | <ul style="list-style-type: none"> <li>▪ In air from 100 MHz to 3.0 GHz (absolute accuracy <math>\pm 6\%</math>; k=2)</li> </ul>  |
| <b>Frequency</b>     | <ul style="list-style-type: none"> <li>▪ 100MHz to 6 GHz</li> <li>▪ Linearity: <math>\pm 0.2\text{dB}</math> (100MHz to 3GHz)</li> </ul>  |
| <b>Directivity</b>   | <ul style="list-style-type: none"> <li>▪ <math>\pm 0.2\text{ dB}</math> in air (rotation around probe axis)</li> <li>▪ <math>\pm 0.4\text{ dB}</math> in air (rotation normal to probe axis)</li> </ul>   |
| <b>Dynamic Range</b> | <ul style="list-style-type: none"> <li>▪ 2 V/m to &gt; 1000 V/m</li> <li>▪ Linearity: <math>\pm 0.2\text{ dB}</math></li> </ul>   |
| <b>Dimensions</b>    | <ul style="list-style-type: none"> <li>▪ Overall length: 330 mm (Tip: 16 mm)</li> <li>▪ Tip diameter: 8 mm (Body: 12 mm)</li> <li>▪ Distance from probe tip to dipole centers: 2.5 mm</li> </ul>  |
| <b>Application</b>   | <ul style="list-style-type: none"> <li>▪ General near-field measurements up to 6 GHz</li> <li>▪ Field component measurements</li> <li>▪ Fast automatic scanning in phantoms</li> </ul>  |

#### 5.4 Isotropic H-Field Probe

|                             |   |
|-----------------------------|---|
| <b>Model</b>                | <ul style="list-style-type: none"> <li>▪ H3DV5</li> </ul>   |
| <b>Construction</b>         | <ul style="list-style-type: none"> <li>▪ Three concentric loop sensors with 3.8 mm loop diameters</li> <li>▪ Resistively loaded detector diodes for linear response</li> <li>▪ Built-in shielding against static charges</li> <li>▪ PEEK enclosure material (resistant to organic solvents, e.g., glycolether)</li> </ul> |
| <b>Frequency</b>            | <ul style="list-style-type: none"> <li>▪ 200 MHz to 3 GHz (<math>\pm 6.0\%</math>, <math>k=2</math>); Output linearized</li> </ul>  |
| <b>Directivity</b>          | <ul style="list-style-type: none"> <li>▪ <math>\pm 0.25</math> dB (spherical isotropy error)</li> </ul>   |
| <b>Dynamic Range</b>        | <ul style="list-style-type: none"> <li>▪ 10 mA/m to 2 A/m at 1 GHz</li> </ul>   |
| <b>E-Field Interference</b> | <ul style="list-style-type: none"> <li>▪ <math>&lt; 10\%</math> at 3 GHz (for plane wave)</li> </ul>  |
| <b>Dimensions</b>           | <ul style="list-style-type: none"> <li>▪ Overall length: 330 mm (Tip: 40 mm)</li> <li>▪ Tip diameter: 6 mm (Body: 12 mm)</li> <li>▪ Distance from probe tip to dipole centers: 3 mm</li> </ul>  |
| <b>Application</b>          | <ul style="list-style-type: none"> <li>▪ General magnetic near-field measurements up to 3 GHz</li> <li>▪ Field component measurements</li> <li>▪ Surface current measurements</li> <li>▪ Measurements in air or liquids</li> <li>▪ Low interaction with the measured field</li> </ul>                                     |

## 6 System Validation

The manufacturer calibrates the probes annually. The HAC measurements of the device were done within 24 hours of system accuracy verification, which was done using calibration dipoles. Unmodulated continuous wave of power level of 20dBm was supplied to a dipole antenna placed under Test Arch. The measurement probes are positioned over the illuminated dipole at 10mm distance from the top surface of the dipole element to the calibration reference point of the sensor, defined by the probe manufacturer.

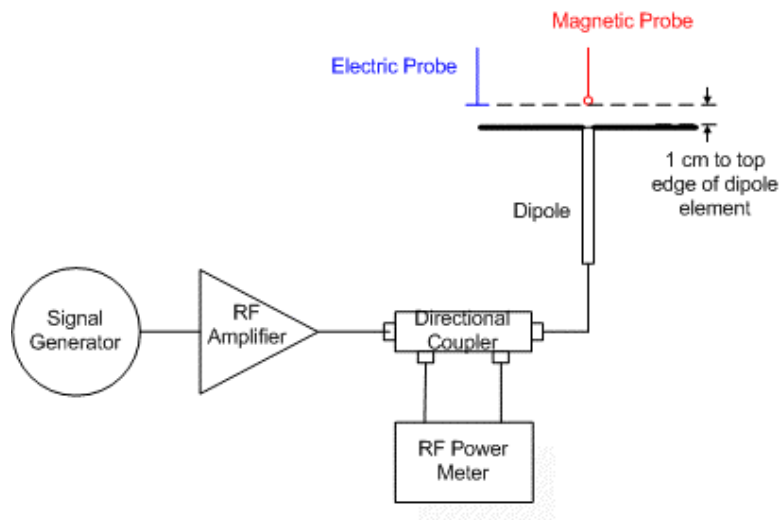

Figure 6 - System Check Setup

The length of the dipole was scanned with both E and H-field probes and the maximum values for each were recorded. The validation results are in the table below and printouts of the validation test are attached in Appendix B. All the measured parameters were within the specification.

| Freq. (MHz) | Parameter | Target | Measured | Delta (%) | Limit (%) | Test date |
|-------------|-----------|--------|----------|-----------|-----------|-----------|
| 1880        | E dB(V/m) | 140    | 140.6    | 0.43      | ± 25      | 05-10-06  |
|             | H dB(A/m) | 0.458  | 0.479    | 4.54      | ± 25      | 05-10-06  |



## 7 Description Of The Test Procedure

The device was positioned and setup according to ANSI PC63.19-2005.

### 7.1 Test Positions

The device was placed on a non-conductive phone positioner under the Test Arch.

### 7.2 RF Emission Measurements Reference and Plane

Figure 7.2 illustrates the references and reference plane that shall be used in the EUT emissions measurement:

- The grid is 5 cm by 5 cm area that is divided into 9 evenly sized blocks or sub-grids.
- The grid is centered on the audio frequency output transducer (speaker) of the EUT.
- The grid is in a reference plane, which is defined as the planar area that contains the highest point in the area of the phone that normally rests against the user's ear. It is parallel to the centerline of the receiver of the EUT and is defined by the points of the receiver-end of the EUT, which, in normal handset use, rest against the ear.
- The measurement plane is parallel to, and 1.0 cm in front of, the reference plane.

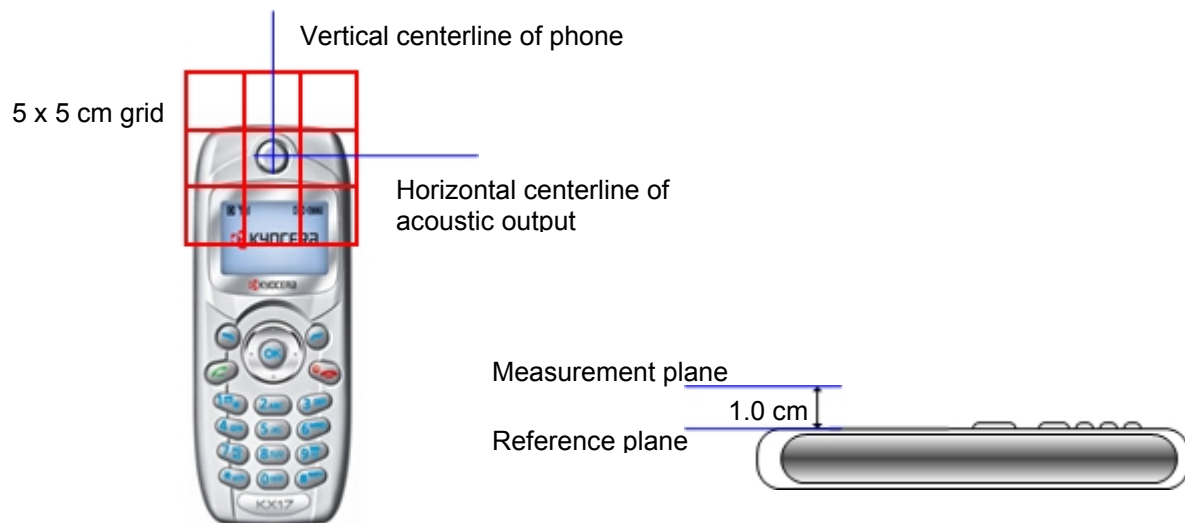

Figure 7.2 – Measurement Reference and Plane

### 7.3 RF Emissions Measurement Procedures

Figure 7.6 shows the near field emission measurement flowchart:

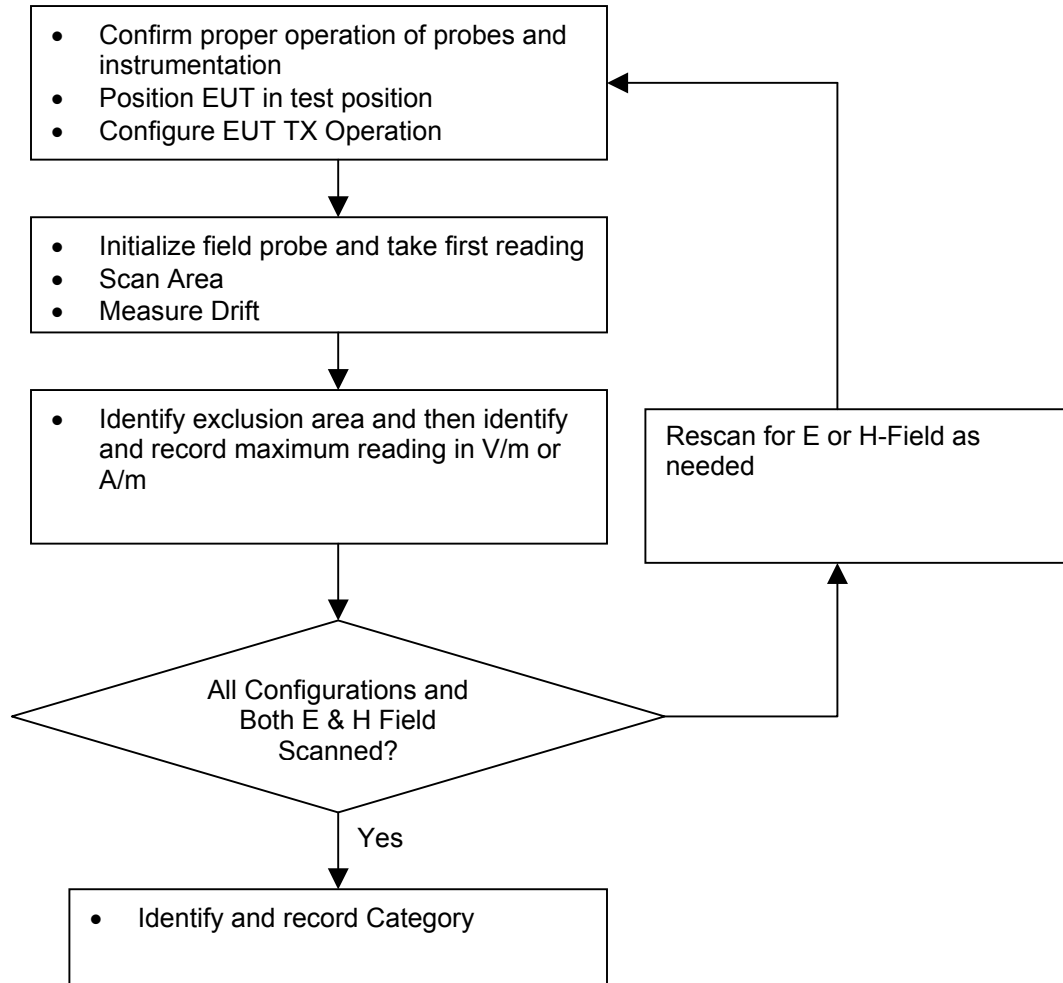

Figure 7.3 - Near field emission measurement flowchart

1. The center of the probe was scanning to the edges of the grid. Accordingly the total area covered by the outside edge of the probe was the 5 cm by 5 cm area, increased by half (1/2) the probe diameter on all sides.
2. The nearest point on the probe measurement element(s) was held 1.0 cm from the EUT reference plane.
3. The probe element is that portion of the probe that is designed to receive and sense the field being measured.
4. The physical body of the probe housing was not used when setting this 1.0 cm distance as this would place the sensing elements at an indeterminate distance from the reference plane.
5. The step size of the scan is set to 5 mm or less.
6. Up to three blocks were excluded for each field measurement.
  - The center block containing the EUT output was not excluded.
  - A maximum of five blocks were excluded for both E- and H-field measurements for the EUT output being measured. Stated differently, the center sub-grid or block and 3 other blocks were common to both the E- and H-field measurements for a given grid.

## 7.4 Probe Modulation Factor (PMF)

### 7.4.1 Measurement Procedures

A calibration was made of the modulation response of the probe and its instrumentation chain. This calibration was performed with the field probe, attached to its instrumentation. The response of the probe system to a CW field at the frequency of interest is compared to its response to a modulated signal with equal peak amplitude to that of a CW signal. The field level of the test signals shall be more than 10 dB above the ambient level and the noise floor of the instrumentation being used. The ratio of the CW reading to that taken with a modulated reading was applied to the DUT measurements. The measurement procedures are as following:

1. Fix the field probe in a set location relative to the dipole antenna, as illustrated in Figure 7.4.
2. Setup the wireless device (EUT) with intended signal at the intended measurement frequency.
3. Record the reading of the probe measurement system.
4. Replace the wireless device with a RF signal generator producing an unmodulated CW signal and set to the wireless device operating frequency.
5. Set the peak power of the unmodulated signal to equal that recorded from the wireless device
6. Record the reading of the probe measurement system of the unmodulated CW signal.
7. The ratio of probe reading (CW) in step 6 to the probe reading (EUT) in step 3 is the modulation factor.

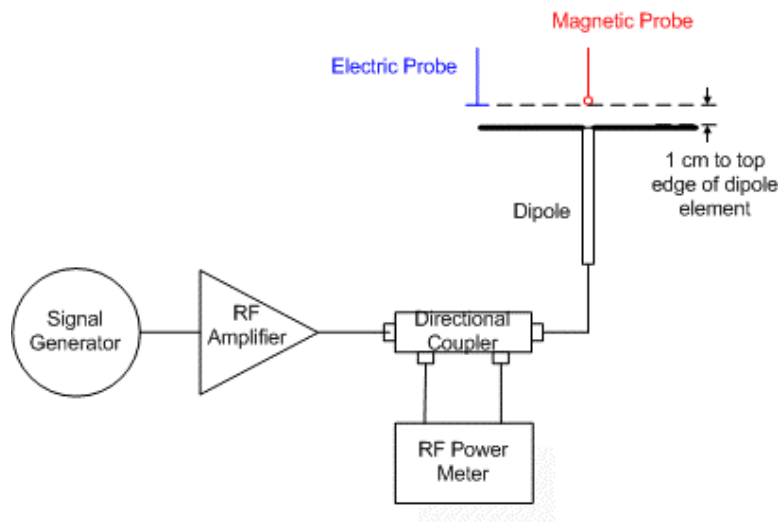

Figure 7.4 - Probe Modulation Setup

The modulation factors obtained by above method shall be applied to readings taken of the actual WD, in order to obtain an accurate peak field reading.

7.4.2 PMF Test Results

| E-Field         |                  |          |                        |           |          |
|-----------------|------------------|----------|------------------------|-----------|----------|
| Frequency (MHz) | Peak Power (dBm) | Protocol | Protocol Reading (V/m) | PMF Ratio | PMF (dB) |
| 1880            | 22.87            | CW       | 92.67                  |           |          |
|                 | 22.83            | CDMA     | 93.84                  | 0.99      | -0.109   |
|                 | 22.84            | AM       | 59.79                  | 1.55      | 3.806    |
| H-Field         |                  |          |                        |           |          |
| Frequency (MHz) | Peak Power (dBm) | Protocol | Protocol Reading (A/m) | PMF Ratio | PMF (dB) |
| 1880            | 22.91            | CW       | 0.3549                 |           |          |
|                 | 22.89            | CDMA     | 0.3624                 | 0.98      | -0.2     |
|                 | 22.89            | AM       | 0.2355                 | 1.51      | 3.6      |

7.4.3 PMF Peak Power Measurement Plots

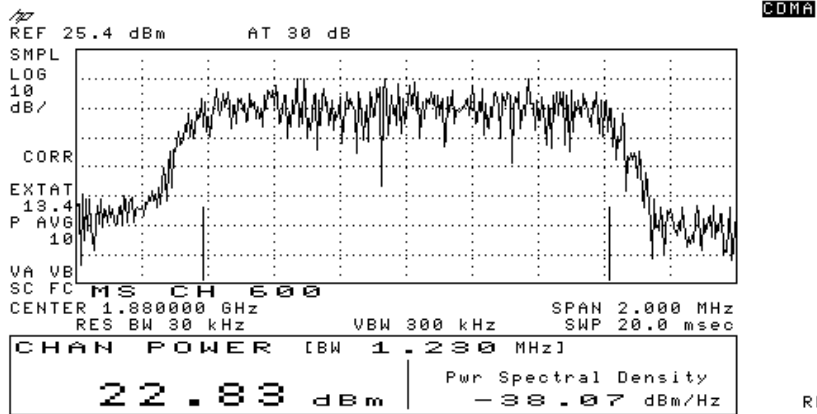

CDMA-1900

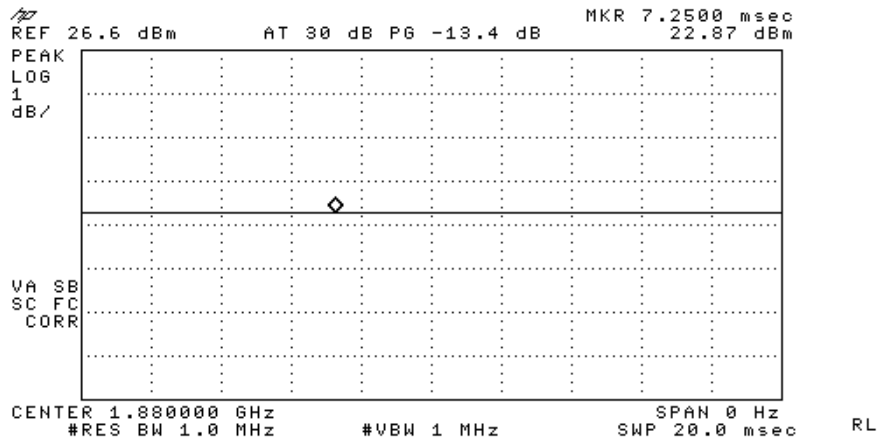

CW

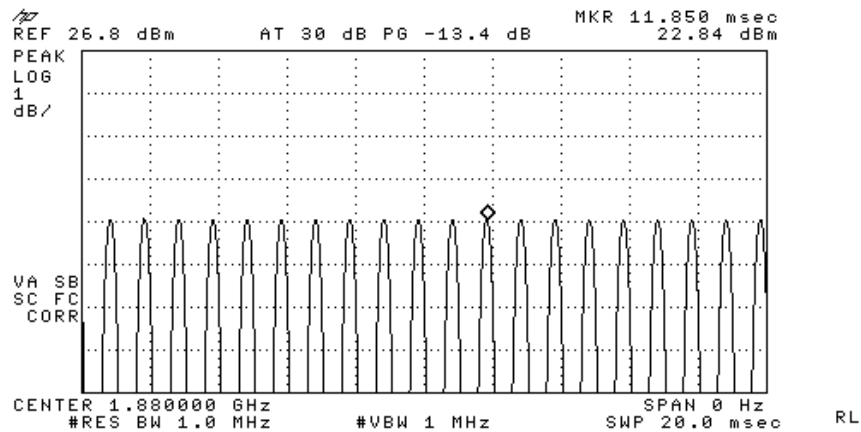

80% AM

**8 Emission Data Extraction and Post processing**

At the end of the measurements, the DASY4 system automatically evaluates the slot-averaged results, exclusion of the three highest sub-grid, application of the AWF factor per ANSI-C63.19 requirements.

The following AWF factors were used for the standard transmission protocols:

| Standard        | Technology         | AWF |
|-----------------|--------------------|-----|
| TIA/EIA/IS-2000 | CDMA               | 0   |
| TIA/EIA-136     | TDMA (50 Hz)       | 0   |
| J-STD-007       | GSM (217)          | -5  |
| T1/T1P1/3GPP    | UMTS (WCDMA)       | 0   |
| iDEN™           | TDMA(22 and 11 Hz) | 0   |

Table 7.5a - Articulation Weighting Factor (AWF)

All DASY4 measurements are in RMS values. The Dasy4 system incorporates the crest factor of the signal in the computation of the RMS values. Although the software also has the capability to estimate the peak field by applying a square root of the crest factor value to the readings, the probe modulation factor was applied manually instead per ANSI PC63.19 in the measurement tables in this report using equation:

$$\text{Peak Field} = (\text{DASY4 reading}) \times \text{PMF}$$

where DASY4 reading = measurement from DASY4 in V/m or A/m  
 PMF = Probe Modulation Factor in linear unit

**9 Measurement Uncertainty**

Table 7.5b shows the uncertainty budget for HAC free field assessment according to ANSI PC63.19-2005. The budget is valid for the frequency range 800 MHz - 3 GHz and represents a worst-case analysis. For specific tests and configurations, the uncertainty could be smaller.

| Uncertainty Description                              | Uncert. Value (± %) | Prob. Dist. | Div. | C <sub>i</sub> (E) | C <sub>i</sub> (H) | Stand. Uncert (E) (±%) | Stand. Uncert (H) (±%) |
|--|---------------------|-------------|------|--------------------|--------------------|------------------------|------------------------|
| <b>Measurement system</b>                            |                     |             |      |                    |                    |                        |                        |
| Probe calibration                                    | 5.1                 | N           | 1    | 1                  | 1                  | 5.1                    | 5.1                    |
| Axial isotropy of the probe                          | 4.7                 | R           | √3   | 1                  | 1                  | 2.7                    | 2.7                    |
| Sensor displacement                                  | 16.5                | R           | √3   | 1                  | 0.145              | 9.5                    | 1.4                    |
| Boundary effects                                     | 2.4                 | R           | √3   | 1                  | 1                  | 1.4                    | 1.4                    |
| Probe linearity                                      | 4.7                 | R           | √3   | 1                  | 1                  | 2.7                    | 2.7                    |
| Scaling to Peak Envelope Power                       | 2.0                 | R           | √3   | 1                  | 1                  | 1.2                    | 1.2                    |
| System Detection limit                               | 1.0                 | R           | √3   | 1                  | 1                  | 0.6                    | 0.6                    |
| Readout electronics                                  | 0.3                 | N           | 1    | 1                  | 1                  | 0.3                    | 0.3                    |
| Response time  | 0.8                 | R           | √3   | 1                  | 1                  | 0.5                    | 0.5                    |
| Integration time                                     | 2.6                 | R           | √3   | 1                  | 1                  | 1.5                    | 1.5                    |
| RF ambient conditions                                | 3.0                 | R           | √3   | 1                  | 1                  | 1.7                    | 1.7                    |
| RF Reflections                                       | 12                  | R           | √3   | 1                  | 1                  | 6.9                    | 6.9                    |
| Probe Positioner                                     | 1.2                 | R           | √3   | 1                  | 0.67               | 0.7                    | 0.5                    |
| Probe positioning                                    | 4.7                 | R           | √3   | 1                  | 0.67               | 2.7                    | 1.8                    |
| Extrap. and integration                              | 1.0                 | R           | √3   | 1                  | 1                  | 0.6                    | 0.6                    |
| <b>Test Sample Related</b>                           |                     |             |      |                    |                    |                        |                        |
| Device positioning vertical                          | 4.7                 | R           | √3   | 1                  | 0.67               | 2.7                    | 1.8                    |
| Device Positioning Lateral                           | 1.0                 | R           | √3   | 1                  | 1                  | 0.6                    | 0.6                    |
| Device Holder and Phantom                            | 2.4                 | R           | √3   | 1                  | 1                  | 1.4                    | 1.4                    |
| Power drift  | 5.0                 | R           | √3   | 1                  | 1                  | 2.9                    | 2.9                    |
| <b>Phantom and Setup Related</b>                     |                     |             |      |                    |                    |                        |                        |
| Phantom thickness                                    | 2.4                 | R           | √3   | 1                  | 0.67               | 1.4                    | 0.9                    |
| <b>Combined Standard Uncertainty:</b>                |                     |             |      |                    |                    | 14.7                   | 10.9                   |
| <b>Extended Standard Uncertainty on Power (k=2):</b> |                     |             |      |                    |                    | 29.4                   | 21.8                   |
| <b>Extended Standard Uncertainty on Field (k=2):</b> |                     |             |      |                    |                    | <b>14.7</b>            | <b>10.9</b>            |

N: Normal  
R: Rectangular

Table 7.5b - Worst-Case uncertainty budget for HAC free field assessment

**10 RF Emissions Tests**

**10.1 Emission Limits**

Table 8.1 shows the M-rating criteria from ANSCI C63.19. All digital transmission modes in all frequency bands contained in a HAC phone must meet M3 or M4 levels.

| <b>Category</b>   | <b>Wireless Device RF Parameters</b> |   |   |
|-------------------|--------------------------------------|---|---|
| <b>Near Field</b> | <b>AWF</b>                           | <b>E-Field Emissions<br/>dB(V/m) Peak</b> | <b>H-Field Emissions<br/>dB(A/m) Peak</b> |
| M1                | AWF = 0                              | 46.0 to 51.0                              | -4.4 to 0.6                               |
| M2                | AWF = 0                              | 41.0 to 46.0                              | -9.4 to -4.4                              |
| M3                | AWF = 0                              | 36.0 to 41.0                              | -14.4 to -9.4                             |
| M4                | AWF = 0                              | < 36.0                                    | < -14.4                                   |

Table 10.1 - RF Emission Limits



10.2 CDMA 1900 Test Results

| CDMA 1900 E-Field |           |          |                   |                  |               |        |              |          |
|-------------------|-----------|----------|-------------------|------------------|---------------|--------|--------------|----------|
| Configuration:    |           | Open     |                   |                  | Antenna       | Stubby |              |          |
| Ch.               | Backlight | Battery  | Power before Test | Power after Test | Dasy4 Reading | PMF    | Peak Field   | Category |
| #                 |           |          | dBm               | dBm              | V/m           |        | V/m          | M        |
| 25                | ON        | Standard | 22.97             | 23.03            | 52.10         | 1.00   | 52.10        | 4        |
| 600               | ON        | Standard | 23.22             | 23.24            | 53.40         | 1.00   | <b>53.40</b> | 4        |
| 1175              | ON        | Standard | 22.84             | 22.76            | 44.40         | 1.00   | 44.40        | 4        |
| 600               | ON        | Extended | 23.22             | 23.24            | 46.10         | 1.00   | 46.10        | 4        |
|                   |           |          |                   |                  |               |        |              |          |
| 600               | OFF       | Standard | 23.22             | 23.24            | 52.00         | 1.00   | 52.00        | 4        |
| 600               | OFF       | Extended | 23.22             | 23.24            | 49.70         | 1.00   | 49.70        | 4        |

Data plots are shown in Appendix C

| CDMA 1900 H-Field |           |          |                   |                  |               |        |             |          |
|-------------------|-----------|----------|-------------------|------------------|---------------|--------|-------------|----------|
| Configuration:    |           | Open     |                   |                  | Antenna       | Stubby |             |          |
| Ch.               | Backlight | Battery  | Power before Test | Power after Test | Dasy4 Reading | PMF    | Peak Field  | Category |
| #                 |           |          | dBm               | dBm              | A/m           |        | A/m         | M        |
| 25                | ON        | Standard | 22.97             | 23.03            | 0.13          | 1.00   | 0.13        | 4        |
| 600               | ON        | Standard | 23.22             | 23.24            | 0.14          | 1.00   | <b>0.14</b> | 4        |
| 1175              | ON        | Standard | 22.84             | 22.76            | 0.12          | 1.00   | 0.12        | 4        |
| 600               | ON        | Extended | 23.22             | 23.24            | 0.13          | 1.00   | 0.13        | 4        |
|                   |           |          |                   |                  |               |        |             |          |
| 600               | OFF       | Standard | 23.22             | 23.24            | 0.14          | 1.00   | 0.14        | 4        |
| 600               | OFF       | Extended | 23.22             | 23.24            | 0.13          | 1.00   | 0.13        | 4        |

Data plots are shown in Appendix C

### **10.3 Worst-Case Configuration Evaluation**

#### **10.3.1 Peak Reading 360° Probe Rotation at Azimuth axis**

The probe was rotated 360° in the worst case configuration. The rotation was performed at the location of maximum field strength in the included blocks.

Data plots are shown in Appendix C

11 Test setup photos

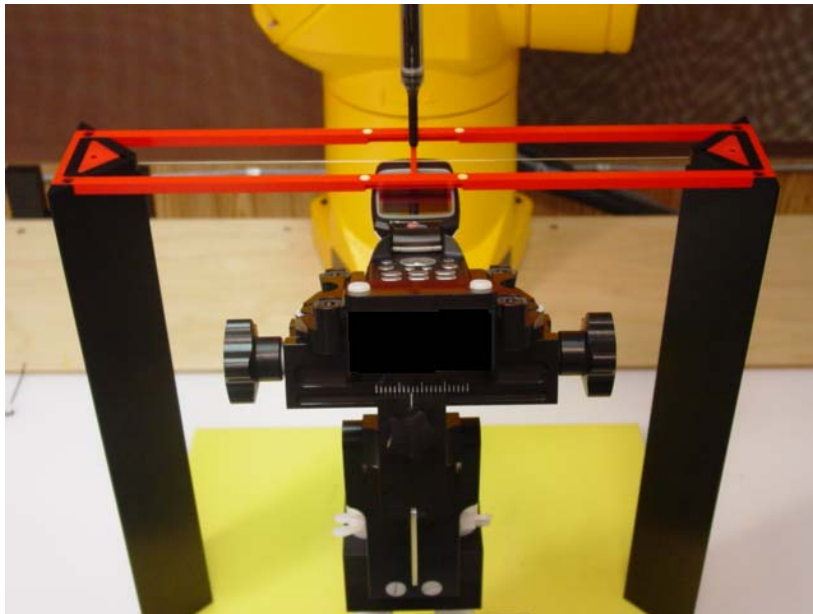

Figure 11a - Open



Figure 11b - Open (close-up)

# Appendix A: Probe Calibration Certification

**Calibration Laboratory of  
Schmid & Partner  
Engineering AG**  
Zeughausstrasse 43, 8004 Zurich, Switzerland



**S** Schweizerischer Kalibrierdienst  
**C** Service suisse d'étalonnage  
**S** Servizio svizzero di taratura  
**S** Swiss Calibration Service

Accredited by the Swiss Federal Office of Metrology and Accreditation  
The Swiss Accreditation Service is one of the signatories to the EA  
Multilateral Agreement for the recognition of calibration certificates

Accreditation No.: **SCS 108**

Client: **Kyocera USA**

Certificate No: **ER3-2282\_Oct05**

## CALIBRATION CERTIFICATE

Object: **ER3DV6 - SN:2282**

Calibration procedure(s): **QA-CAL-02-v4  
Calibration procedure for E-field probes optimized for close near field  
evaluations in air**

Calibration date: **October 21, 2005**

Condition of the calibrated item: **In Tolerance**

This calibration certificate documents the traceability to national standards, which realize the physical units of measurements (SI).  
The measurements and the uncertainties with confidence probability are given on the following pages and are part of the certificate.

All calibrations have been conducted in the closed laboratory facility: environment temperature (22 ± 3)°C and humidity < 70%.

Calibration Equipment used (M&TE critical for calibration)

| Primary Standards          | ID #            | Cal Date (Calibrated by, Certificate No.) | Scheduled Calibration  |
|----------------------------|-----------------|---|------------------------|
| Power meter E4419B         | GB41293874      | 3-May-05 (METAS, No. 251-00466)           | May-06                 |
| Power sensor E4412A        | MY41496277      | 3-May-05 (METAS, No. 251-00466)           | May-06                 |
| Power sensor E4412A        | MY41498087      | 3-May-05 (METAS, No. 251-00466)           | May-06                 |
| Reference 3 dB Attenuator  | SN: S5054 (3c)  | 11-Aug-05 (METAS, No. 251-00499)          | Aug-06                 |
| Reference 20 dB Attenuator | SN: S5086 (20b) | 3-May-05 (METAS, No. 251-00467)           | May-06                 |
| Reference 30 dB Attenuator | SN: S5129 (30b) | 11-Aug-05 (METAS, No. 251-00500)          | Aug-06                 |
| Reference Probe ER3DV6     | SN: 2328        | 3-Oct-05 (SPEAG, No. ER3-2328_Oct05)      | Oct-06                 |
| DAE4                       | SN: 654         | 29-Nov-04 (SPEAG, No. DAE4-654_Nov04)     | Nov-05                 |
| Secondary Standards        | ID #            | Check Date (in house)                     | Scheduled Check        |
| RF generator HP 8648C      | US3642U01700    | 4-Aug-89 (SPEAG, in house check Dec-03)   | In house check: Dec-05 |
| Network Analyzer HP 8753E  | US37390585      | 18-Oct-01 (SPEAG, in house check Nov-04)  | In house check: Nov-05 |

|                | Name          | Function              | Signature |
|----------------|---------------|-----------------------|-----------|
| Calibrated by: | Nico Vetterli | Laboratory Technician |           |
| Approved by:   | Katia Pokovic | Technical Manager     |           |

Issued: October 24, 2005

This calibration certificate shall not be reproduced except in full without written approval of the laboratory.

03 9988

**Calibration Laboratory of  
Schmid & Partner  
Engineering AG**  
Zeughausstrasse 43, 8004 Zurich, Switzerland



**S** Schweizerischer Kalibrierdienst  
**C** Service suisse d'étalonnage  
**S** Servizio svizzero di taratura  
**S** Swiss Calibration Service

Accredited by the Swiss Federal Office of Metrology and Accreditation  
The Swiss Accreditation Service is one of the signatories to the EA  
Multilateral Agreement for the recognition of calibration certificates

Accreditation No.: **SCS 108**

Client **Kyocera USA**

Certificate No: **H3-6029\_Jun05**

**CALIBRATION CERTIFICATE**

Object **H3DV5 - SN:6029**

Calibration procedure(s) **QA CAL-03.v4  
Calibration procedure for H-field probes optimized for close near field  
evaluations in air**

Calibration date: **June 13, 2005**

Condition of the calibrated item **In Tolerance**

This calibration certificate documents the traceability to national standards, which realize the physical units of measurements (SI).  
The measurements and the uncertainties with confidence probability are given on the following pages and are part of the certificate.

All calibrations have been conducted in the closed laboratory facility: environment temperature (22 ± 3)°C and humidity < 70%.

Calibration Equipment used (M&TE critical for calibration)

| Primary Standards          | ID #            | Cal Date (Calibrated by, Certificate No.) | Scheduled Calibration  |
|----------------------------|-----------------|---|------------------------|
| Power meter E4419B         | GB41293874      | 3-May-05 (METAS, No. 251-00466)           | May-06                 |
| Power sensor E4412A        | MY41495277      | 3-May-05 (METAS, No. 251-00466)           | May-06                 |
| Power sensor E4412A        | MY41498087      | 3-May-05 (METAS, No. 251-00466)           | May-06                 |
| Reference 3 dB Attenuator  | SN: S5054 (3c)  | 10-Aug-04 (METAS, No. 251-00403)          | Aug-05                 |
| Reference 20 dB Attenuator | SN: S5086 (20b) | 3-May-05 (METAS, No. 251-00467)           | May-06                 |
| Reference 30 dB Attenuator | SN: S5129 (30b) | 10-Aug-04 (METAS, No. 251-00404)          | Aug-05                 |
| Reference Probe H3DV6      | SN: 6182        | 6-Oct-04 (SPEAG, No. H3-6182_Oct04)       | Oct-05                 |
| DAE4                       | SN: 617         | 19-Jan-05 (SPEAG, No. DAE4-617_Jan05)     | Jan-06                 |
| Secondary Standards        | ID #            | Check Date (in house)                     | Scheduled Check        |
| RF generator HP 8648C      | US3642U01700    | 4-Aug-99 (SPEAG, in house check Dec-03)   | In house check: Dec-05 |
| Network Analyzer HP 8753E  | US37390585      | 18-Oct-01 (SPEAG, in house check Nov-04)  | In house check: Nov 05 |

|                | Name          | Function              | Signature |
|----------------|---------------|-----------------------|-----------|
| Calibrated by: | Nico Vetterli | Laboratory Technician |           |
| Approved by:   | Katja Pokovic | Technical Manager     |           |

Issued: June 13, 2005

This calibration certificate shall not be reproduced except in full without written approval of the laboratory.

## **Appendix B: System Validation Data**

(See attachment)

## Appendix C: Test Results/Plots

(See attachment)