



Nemko USA, Inc
11696 Sorrento Valley Rd., Suite F
San Diego, CA 92121-1024

EMC TEST REPORT
Kyocera Wireless Corp.
KE423-K7 Cell Phone

Model: **Gray Blade**

RADIATED EMISSIONS

FCC, PART 2.1053

FCC, PART 15.109

FCC, PART 24 SUBPART D

INDUSTRY CANADA, RSS-133

TEST REPORT # 2005 010403 A FCC

24-403-KYO

NEMKO USA, INC.
11696 SORRENTO VALLEY ROAD SUITE F
SAN DIEGO, CA 92121
PHONE: 858-755-5525

TABLE OF CONTENTS

1. DESCRIPTION OF TESTING METHODS.....	7
2. TEST RESULTS.....	11

TEST SETUP DIAGRAMS

FIGURE 1. GENERAL EUT TEST SETUP PICTURE	8
FIGURE 2. RADIATED EMISSIONS TEST SETUP DIAGRAM.....	10

TEST CONFIGURATION PHOTOGRAPHS

PHOTOGRAPH 1. FCC, PART 24 RADIATED EMISSIONS TEST CONFIGURATION	16
PHOTOGRAPH 2. FCC, PART 15 RADIATED EMISSIONS TEST CONFIGURATION	18

APPENDICES

A. RADIATED EMISSIONS MEASUREMENT UNCERTAINTIES	18
B. NEMKO USA, INC.'S TEST EQUIPMENT & FACILITIES CALIBRATION PROGRAM.....	20
C. FCC AND NVLAP ACCREDITATION	22

EMC Test Report
For
Kyocera Wireless Corp.

Test Number : 24-403-EMC

Product Name : **KE423-K7 Cell Phone**

Regulation : FCC, Part 15.109
: FCC, Part 24, Subpart D
: Industry Canada, RSS-133

Date : JANUARY 18, 2005

Report Reviewed

Accepted by: _____

Kyocera Wireless Corp.
10300 Campus Point Drive
San Diego, CA 92121
Phone: **858 882-2879**
Fax: **858 882-2010**

Report Issued By: *FR Fleury*

For Ricky Hill, Senior EMC Engineer

Tested By: *Mike Krumweide*

Mike Krumweide, EMC Test Engineer

Administrative Data

Regulation : FCC, Part 15.109
: FCC, Part 24, Subpart D
: Industry Canada, RSS-133

Level : Not Applicable

Test Method : ANSI C63.4 – 2002
: CSA C108. - M1983

Test Type : Verification
Manufacturer : **Kyocera Wireless Corp.**
EUT Type/:Model # : **Gray Blade**
Date(s) of Test : January 14, 2005
Customer Personnel : John Turner, Engineer

Nemko Personnel : R. Hill, Senior EMC Engineer
: Mike Krumweide, EMC Test Engineer

Test Location : OPEN Area Test Site
Nemko USA, Inc.
11696 Sorrento Valley Road, Suite F
San Diego, CA 92121

EUT Description

The **Gray Blade** is a **KE423-K7 Cell Phone**. The EUT was exercised by setting it to continuously transmit at required test frequencies or the set receive mode through external control from laptop and control software. The laptop was then removed from the test setup. Its function is to provide wireless communications for personal use. The EUT was exercised in PCS Transmit and Receive for radiated emissions.

Design Modifications for Compliance.

The tests were run in a typical configuration including the following support equipment and cable connections.

DEVICE	MANUFACTURER	POWER CABLE
	MODEL # SERIAL #	
EUT - KE423-K7 Cell Phone	Kyocera Wireless Corp. Model: Gray Blade SN: GM-T----15L7GB	N/A

CONNECTION	I/O CABLE
No connections	

REASON FOR TEST

The EUT was tested to qualify for FCC Part 15.109 and Part 24, and RSS-133.

CHANGES MADE DURING TEST

The following design modifications were made to the EUT during testing.

No design modifications were made to the EUT during testing.

DEVIATIONS FROM STANDARD TEST METHOD

-- None

CERTIFICATION AND TEST SUMMARY

<i>Test Type</i>	<i>In Accordance with Document</i>	<i>Frequency Range Investigated</i>	<i>EUT Complies</i>
Radiated Emissions	EN 55022 (1998)A1 Class "B" FCC 15.109	30 MHz to 1000 MHz	PASS
Radiated Spurious Emissions	FCC, Part 24, Subpart D Industry Canada, RSS-133	1851 – 1909 MHz	PASS

The **KE423-K7 Cell Phone** complied with FCC Part 15.109 and Part 24, Industry Canada, RSS-133 when tested in the system configuration defined herein.

1. DESCRIPTION OF TEST SITE AND EQUIPMENT

1.1. Description of Test Site

The test site is located at 11696 Sorrento Valley Road, Suite F, San Diego, CA 92121. The site is physically located 18 miles Northwest of downtown San Diego. The general area is a valley 1.5 miles east of the Pacific Ocean. This particular part of the valley tends to minimize ambient levels, i.e. radio and TV broadcast stations and land mobile communications. The three and ten-meter Open Area Test Site (OATS) is located behind the office/lab building. It conforms to the normalized site attenuation limits and construction specifications as set in the EN 55022 (1998), CISPR 16 (2000) and 22 (1997) and ANSI C63.4-2002 documents. The OATS normalized site attenuation characteristics are verified for compliance every.

DESCRIPTION OF TESTING METHODS

1.2. Introduction

As required in 47 CFR, Parts 2 and 15, the methods employed to test the radiated and conducted emissions (as applicable) of the EUT are those contained within the American National Standards Institute (ANSI) document C63.4-2002, titled "Methods of Measurement of Radio-Noise Emissions from Low-Voltage Electrical and Electronic Equipment in the Range of 9 kHz to 40 GHz." All applicable FCC Rule Sections that provide further guidance for performance of such testing are also observed.

For General Test Configuration please refer to Figure 1 on the following page.

Digital devices sold in Canada are required to comply with the Interference Causing Equipment Standard for Digital Apparatus, ICES-003. These test methods and limits are specified in the Canadian Standards Association's (CSA) Standard C108.8-M1983 (1-1-94 version) and are "essentially equivalent" with FCC, Part 15 and CISPR 22 (EN55022) rules for unintentional radiators per EMCAB-3, Issue 3 (May 1998). No further testing is required for compliance to ICES-003.

Figure 1. General EUT Test Setup Picture



CONFIGURATION LEGEND

1. EUT: **KE423-K7 Cell Phone**
2. 80cm Non-Conductive Support Table

1.3. Configuration and Methods of Measurements for Radiated Emissions

Section 8 of ANSI C63.4 determines the general configuration and procedures for measuring the radiated emissions of equipment under test. Initially, the primary emission frequencies are identified inside the test lab by positioning a broadband receive antenna one meter from the EUT to locate frequencies of significant radiation. Next, the EUT and associated system are placed on a turntable on a ten meter open area test site (registered with the FCC in accord with its Rules and ANSI C63.4) and the receive antenna is located at a distance of ten meters from the EUT.

The EUT and associated system are configured to operate continuously, representing a “normally operating” mode. All significant radiated emissions are recorded when maximum radiation on each frequency is observed, in accordance with part 8 of ANSI C63.4-1992 and Section 15.33 of the FCC Rules. To ensure that the maximum emission at each discrete frequency of interest is observed, the receive antenna is varied in height from one to four meters and rotated to horizontal and vertical polarities, and the turntable is also rotated to determine the worst emitting configuration. The numerical results of the test are included herein to demonstrate compliance.

The numerical results that are applied to the emissions limits are arrived at by the following method:

Example: $A = RR + CL + AF$

A = Amplitude dBuV/M

RR = Receiver Reading dBuV

CL = cable loss dB

AF = antenna factor dBm-1

Example Frequency = 110MHz

18.5 dBuV (spectrum analyzer reading)

+3.0 dB (cable loss @ frequency)

21.5 dBuV

+15.4 dBm-1 (antenna factor @ frequency)

36.9 dBuV/M Final adjusted value

The final adjusted value is then compared to the appropriate emission limit to determine compliance.

For Radiated Emissions Test Configuration please refer to Figure 4 on the following page.

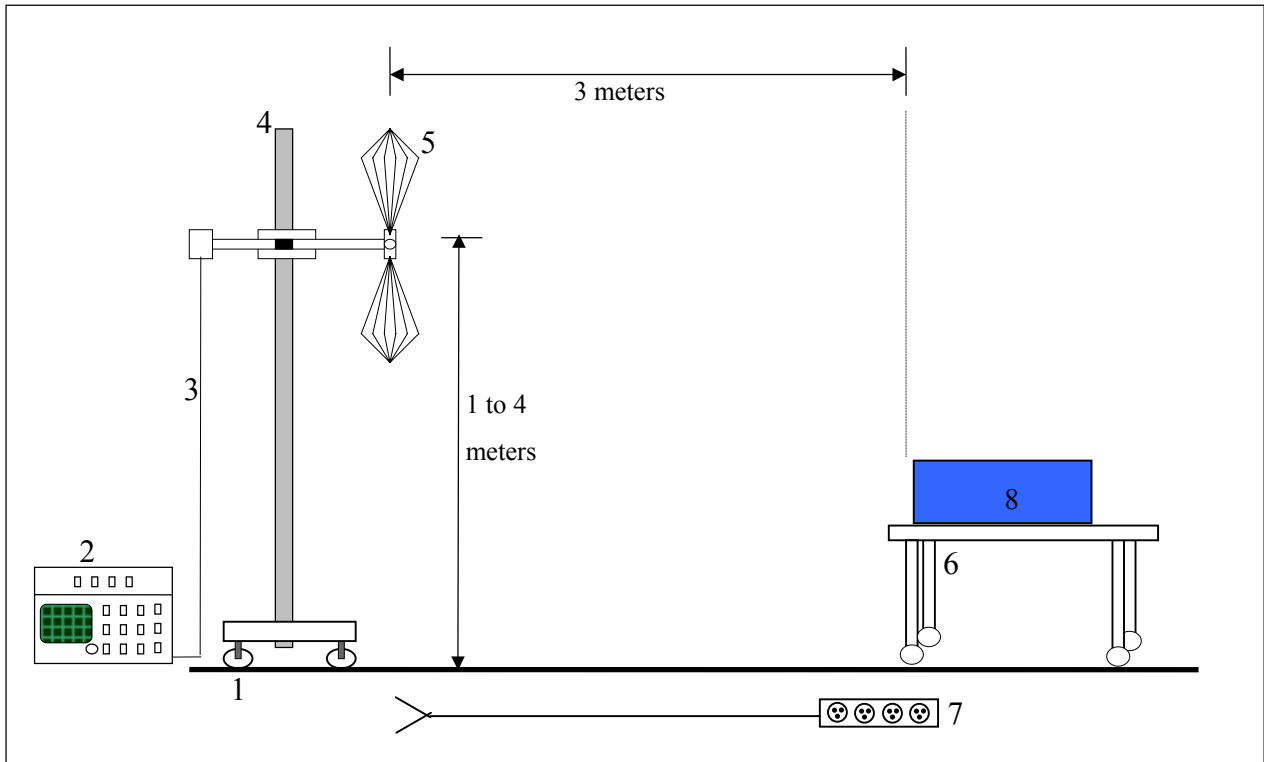
Figure 2. Radiated Emissions Test Setup Diagram*NOT TO SCALE***CONFIGURATION LEGEND**

1. Ground plane (11 X 17 meters)
2. Spectrum Analyzer with Quasi-Peak Adapter
3. Coax interconnect from Receive Antenna to Spectrum Analyzer
4. Antenna Mast with motorized mounting assembly
5. Receive Antenna (basic relative position)
6. Non-Conducting table 80 cm above ground plane
7. AC power for devices
8. EUT: **KE423-K7 Cell Phone**

2. TEST RESULTS

2.1. Radiated Emissions Test Data

Radiated Emissions Data												
						Job # : <u>24-403-KYO</u>	Test # : _____					
						Page <u>1</u>	of		<u>#REF!</u>			
Client Name :	<u>Kyocera</u>											
EUT Name :	<u>Cellular Phone</u>											
EUT Model # :	<u>KE423 - K7 Gray Blade</u>											
EUT Part # :	_____											
EUT Serial # :	<u>GM-T----15L7GB</u>											
EUT Config. :	_____											
<u>PCS Tx Harmonics</u>												
Specification :	<u>FCC Part 24</u>											
Rod. Ant. # :	<u>NA</u>	Temp. (deg. C) :	_____								Reference :	Date : <u>01/14/05</u>
Bicon Ant.# :	<u>NA</u>	Humidity (%) :	_____								Time :	_____
Log Ant.# :	<u>NA</u>	EUT Voltage :	<u>NA</u>								Staff :	<u>Mike Krumweide</u>
DRG Ant. # :	<u>529</u>	EUT Frequency :	<u>NA</u>								Photo ID :	<u>0</u>
Dipole Ant.# :	<u>NA</u>	Phase :	<u>NA</u>								Peak Bandwidth :	<u>1 MHz</u>
Cable# :	<u>40ft</u>	Location :	<u>RN# 90579</u>								Video Bandwidth :	<u>1 MHz</u>
Preamp# :	<u>40db</u>	Distance :	<u>3m</u>									
Spec An.# :	<u>835</u>											
QP # :	<u>NA</u>											
PreSelect# :	<u>NA</u>											

Meas. Freq. (MHz)	Vertical (dBuV) pk	Horizontal (dBuV) pk	CF (db)	Max Level (dBm) pk	Spec. Limit (ERIP) (dBm) pk	Margin dB pk	EUT Rotation	Ant. Height	Pass Fail Unc.	Comment
3760	55.2	52.4	-2.6	-44.63	-13.0	-31.6			Pass	*
5640	49.2	49.2	2.5	-45.53	-13.0	-32.5			Pass	NS, NF
7520	48	48	7	-42.23	-13.0	-29.2			Pass	NS, NF
9400	46.6	46.6	8.84	-41.79	-13.0	-28.8			Pass	NS, NF
11280	45.3	45.3	13.1	-38.83	-13.0	-25.8			Pass	NS, NF
13160	44.1	44.1	18.4	-34.73	-13.0	-21.7			Pass	NS, NF
15040	39.9	39.9	22.5	-34.83	-13.0	-21.8			Pass	NS, NF 500kHz RBW
16920	37.5	37.5	22.8	-36.93	-13.0	-23.9			Pass	NS, NF 500kHz RBW
18800	26.1	26.1	34.8	-36.33	-13.0	-23.3			Pass	NS, NF 100kHz RBW
20690	26.7	26.7	34.8	-35.73	-13.0	-22.7			Pass	NS, NF 100kHz RBW
3702.5	52.7	53.2	-2.6	-46.63	-13.0	-33.6			Pass	*
5553.75	49.2	49.2	2.5	-45.53	-13.0	-32.5			Pass	NS, NF
7405	49.8	49.8	5.8	-41.63	-13.0	-28.6			Pass	NS, NF
9256.25	46.4	46.4	8.84	-41.99	-13.0	-29.0			Pass	NS, NF
11107.5	45.4	45.4	13.1	-38.73	-13.0	-25.7			Pass	NS, NF
12958.8	43.9	43.9	15.4	-37.93	-13.0	-24.9			Pass	NS, NF
14810	41.6	41.6	22.9	-32.73	-13.0	-19.7			Pass	NS, NF 500kHz RBW
16661.3	36.4	36.4	22.8	-38.03	-13.0	-25.0			Pass	NS, NF 500kHz RBW
18512.5	26.7	26.7	34.8	-35.73	-13.0	-22.7			Pass	NS, NF 100kHz RBW
20363.8	25.7	25.7	34.8	-36.73	-13.0	-23.7			Pass	NS, NF 100kHz RBW
3817.5	66	62.5	-2.6	-33.83	-13.0	-20.8			Pass	* w/ 10dB pad
5726.25	51.2	51.2	2.5	-43.53	-13.0	-30.5			Pass	NS, NF
7635	49.8	48.5	7	-40.43	-13.0	-27.4			Pass	*
9543.75	47.4	47.4	8.54	-41.29	-13.0	-28.3			Pass	NS, NF
11452.5	46.3	46.3	13.1	-37.83	-13.0	-24.8			Pass	NS, NF
13361.3	45.3	45.4	18.4	-33.43	-13.0	-20.4			Pass	NS, NF
15270	36.9	36.9	22.5	-37.83	-13.0	-24.8			Pass	NS, NF 500kHz RBW
17178.8	36.5	36.5	27.7	-33.03	-13.0	-20.0			Pass	NS, NF 500kHz RBW
19087.5	25.4	25.4	34.8	-37.03	-13.0	-24.0			Pass	NS, NF 100kHz RBW
20996.3	24.7	24.7	34.8	-37.73	-13.0	-24.7			Pass	NS, NF 100kHz RBW

NS = Not seen, even at a lower RBW NF = Noise Floor measurement. * = Measurement of signal.

Radiated Emissions Data

Job # : 24-403-KYO Test # : _____
 Page 1 of _____

Client Name : Kyocera
 EUT Name : Cellular Phone
 EUT Model # : KE423 - K7 Gray Blade
 EUT Part # : _____
 EUT Serial # : GM-T----15L7GB
 EUT Config. : _____
 Specification : PCS RX
 FCC Part 15.109 Reference : _____
 Rod. Ant. # : NA Temp. (deg. C) : _____ Date : 01/14/05
 Bicon Ant.#: NA Humidity (%) : _____ Time : _____
 Log Ant.#: NA EUT Voltage : NA Staff : Mike Krumweide
 DRG Ant. # 529 EUT Frequency : NA Photo ID: _____
 Dipole Ant.#: NA Phase: NA Peak Measurement Bandwidth: 1 MHz/ 1 MHz
 Cable#: 40ft Location: RN#: 90579 Average Measurement Bandwidth: 1 MHz/ 10 Hz
 Preamp#: 40db Distance: 3m
 Spec An.#: 835
 QP #: NA
 PreSelect#: NA

Meas. Freq. (MHz)	Vertical (dBuV)		Horizontal (dBuV)		CF (db)	Max Level (dBuV/m)		Spec. Limit (dBuV/m)		Margin dB		EUT Rotation	Ant. Height	Pass Fail Unc.	Comment
	pk	av	pk	av		pk	av	pk	av	pk	av				
2114.85	54.2	41.3	53.8	41.3	-7.9	46.3	33.4	74.0	54.0	-27.7	-20.6			Pass	*
4229.7	50.2	36.7	50.4	37.4	-0.8	49.6	36.6	74.0	54.0	-24.4	-17.4			Pass	*
6344.55	49.4		49.4		3.4	52.8		74.0	54.0	-21.2				Pass	NS, NF
8459.4	44.8		44.8		7.5	52.3		74.0	54.0	-21.7				Pass	NS, NF 500kHz
10574.25	41.8		41.8		10.9	52.7		74.0	54.0	-21.3				Pass	NS, NF 500kHz
12689.1	35.7		35.7		15.4	51.1		74.0	54.0	-22.9				Pass	NS, NF 100kHz
14803.95	31		31		22.9	53.9		74.0	54.0	-20.1				Pass	NS, NF 50kHz
16918.8	23.7		23.7		22.8	46.5		74.0	54.0	-27.5				Pass	NS, NF 30kHz
2143.6	52.9	39.8	53.1	40.3	-7.9	45.2	32.4	74.0	54.0	-28.8	-21.6			Pass	*
4287.2	49.9	37.1	50.2	37.6	-0.8	49.4	36.8	74.0	54.0	-24.6	-17.2			Pass	*
6430.8	50.2		50.2		3.4	53.6		74.0	54.0	-20.4				Pass	NS, NF
8574.4	44.7		44.7		7.8	52.5		74.0	54.0	-21.5				Pass	NS, NF 500kHz
10718	41.4		41.4		10.9	52.3		74.0	54.0	-21.7				Pass	NS, NF 500kHz
12861.6	35.2		35.2		15.4	50.6		74.0	54.0	-23.4				Pass	NS, NF 100kHz
15005.2	30.8		30.8		22.5	53.3		74.0	54.0	-20.7				Pass	NS, NF 50kHz
17148.8	23.5		23.5		27.7	51.2		74.0	54.0	-22.8				Pass	NS, NF 30kHz
2172.35	52.3	39.6	52.3	39.4	-7.9	44.4	31.7	74.0	54.0	-29.6	-22.3			Pass	*
4344.7	51	37.8	50.2	37.4	-0.8	50.2	37	74.0	54.0	-23.8	-17.0			Pass	*
6517.05	50.8	37.5	50.9	38	3.4	54.3	41.4	74.0	54.0	-19.7	-12.6			Pass	*
8689.4	45.2		45.2		7.8	53		74.0	54.0	-21.0				Pass	NS, NF 500kHz
10861.75	41.3		41.3		10.9	52.2		74.0	54.0	-21.8				Pass	NS, NF 500kHz
13034.1	34.6		34.6		18.4	53		74.0	54.0	-21.0				Pass	NS, NF 100kHz
15206.45	29.1		29.1		22.5	51.6		74.0	54.0	-22.4				Pass	NS, NF 50kHz
17378.8	22.6		22.6		27.7	50.3		74.0	54.0	-23.7				Pass	NS, NF 30kHz
19551.15	19		19		34.8	53.8		74.0	54.0	-20.2				Pass	NF, NS 30kHz

NS = Not seen, even at a lower RBW

NF = Noise Floor measurement.

* = Measurement of signal.

Radiated Emissions Test Equipment						
Client	Kyocera Wireless Corp.		EUT Name	KE423-K7 Cell Phone		
PAN #	24-403-KYO		EUT Model	Gray Blade		
	<i>Device Type</i>	<i>Model #</i>	<i>Asset #</i>	<i>Used</i>	<i>Cal Done</i>	<i>Cal Due</i>
Pre-Amplifier						
Amplifier	40dB	842	X	4/1/04	4/1/05	
Antenna OATS #1 (South)						
Antenna, Biconical	EMCO	115				
Antenna, Log Periodic	3146	110				
Antenna, Double Ridge Horn	3115	529	X	3/30/04	3/30/05	
Spectrum Analyzer / Receiver						
Quasi-Peak Adapter, HP	85650A	538				
Spectrum Analyzer Display, HP	85662A	537				
Spectrum Analyzer, HP	8568B	711				
Spectrum Analyzer, R&S	RHDFSEK	835	X	12/30/04	12/30/05	

Radiated Emissions Data

Complete _____ Job # : _____ Test # : _____
 Preliminary _____ Page 1 of 1

Client Name : Kyocera Wireless
 EUT Name : Cellular Phone
 EUT Model # : KE423-K7 Gray Blade
 EUT Part # : _____
 EUT Serial # : GM-T----15L7GB
 EUT Config : PCS Receive

Specification : CFR47 Part 15, Subpart B, Class B Reference : _____
 Rod. Ant. # : NA Temp. (deg. C) : _____ Date : 1/17/2004
 Bicon Ant.# : 114 Humidity (%) : _____ Time : _____
 Log Ant.# : 112 EUT Voltage : N/A Staff : MIKE KRUMWEIDE
 DRG Ant. # : NA EUT Frequency : _____ Photo ID: _____
 Dipole Ant.# : NA Phase: _____ Peak Bandwidth: 100 kHz
 Cable# : NOATS Location: RN# 90579 Video Bandwidth 100 kHz
 Preamp# : 826 Distance: 10m
 Spec An.# : NA
 QP # : NA
 PreSelect# : NA

Meas. Freq. (MHz)	Ant. Pol. (H/V)	Atten. (dB)	Meter Reading (dBuV)	Antenna Factor (dB)	Path Loss (dB)	RF Gain (dB)	Corrected Reading (dBuV/m)	Spec. limit (dBuV/m)	CR/SL Diff. (dB)	Pass Fail Unc.	Comment
37.6	H		40.1	11.6	0.9	32.6	20.0	30.0	-10.0	PASS	
40	V		40.5	11.1	1.0	32.6	20.0	30.0	-10.0	PASS	
112.25	V		40.5	14.2	1.8	32.5	24.0	33.5	-9.5	PASS	
116.22	V		37.2	15	1.9	32.6	21.5	33.5	-12.1	PASS	
206.04	V		30.7	11.4	2.6	32.7	12.0	33.5	-21.5	PASS	
341.33	H		26.6	14.2	3.5	32.9	11.4	36.0	-24.6	PASS	
427.46	V		27	15.5	4.0	32.8	13.7	36.0	-22.3	PASS	
942.24	V		27	22.5	6.6	32.2	23.9	36.0	-12.1	PASS	
983.29	V		29.7	23.1	6.9	32.4	27.3	44.0	-16.7	PASS	

Radiated Emissions Test Equipment						
Client	Kyocera Wireless Corp.		EUT Name	KE423-K7 Cell Phone		
PAN #	24-403-KYO		EUT Model	Gray Blade		
	<i>Device Type</i>	<i>Model #</i>	<i>Asset #</i>	<i>Used</i>	<i>Cal Done</i>	<i>Cal Due</i>
Pre-Amplifier						
	Amplifier, Com-Power	PA-103	826	X	10/22/04	10/22/05
Antenna OATS #1 (North)						
	Antenna, Biconical	EMCO	114	X	9/30/04	9/30/5
	Antenna, Log Periodic	3146	112	X	10/22/04	10/22/05
	Antenna, Double Ridge Horn	3115	529			
Spectrum Analyzer / Receiver						
	Quasi-Peak Adapter, HP	85650A	676			
	Spectrum Analyzer Display, HP	85662A	675	X	9/22/04	3/22/05
	Spectrum Analyzer, HP	8568B	674			
	Spectrum Analyzer, R&S	RHDFSEK	835			

Photograph 1. FCC, Part 24 Radiated Emissions Test Configuration



Photograph 2. FCC, Part 15 Radiated Emissions Test Configuration



APPENDIX A

A. Radiated Emissions Measurement Uncertainties**1. Introduction**

ISO Standard 17025 and ANSI/NCSL Z540-1(1994) require that all measurements contained in a test report be “traceable”. “Traceability” is defined in the *International Vocabulary of Basic and General Terms in Metrology* (ISO: 1993) as: “the property of the result of a measurement... whereby it can be related to stated references, usually national or international standards, through an unbroken chain of comparisons, *all having stated uncertainties*”.

The purposes of this Appendix are to “state the *Measurement Uncertainties*” of the conducted emissions and radiated emissions measurements contained in Section 5 of this Test Report, and to provide a practical explanation of the meaning of these measurement uncertainties.

2. Statement of the Worst-Case Measurement Uncertainties for the Conducted and Radiated Emissions Measurements Contained in This Test Report**Table 1: Worst-Case Expanded Uncertainty "U" of Measurement for a k=2 Coverage Factor**

Radiated Emissions Measurement Detection Systems	Applicable Frequency Range	"U" for a k=2 Coverage Factor
HP8568B Spectrum Analyzer with QPA & HP8447F Preamplifier	30 MHz - 200 MHz	+4.0 dB, -4.1 dB
HP8568B Spectrum Analyzer with QPA & HP8447F Preamplifier	200 MHz-1000 MHz	+/- 3.5 dB
HP8566B Spectrum Analyzer with QPA & Preselector	30 MHz - 200 MHz	+3.9 dB, -4.0 dB
HP8566B Spectrum Analyzer with QPA & Preselector	200 MHz-1000 MHz	+/- 3.4 dB
HP8566B Spectrum Analyzer with QPA & HP 8449A Preamplifier	1 GHz - 18 GHz	+2.5 dB, -2.6 dB
HP8566B Spectrum Analyzer with QPA & HP8449A Preamplifier	18 GHz - 40 GHz	+/- 3.4 dB

NOTES:

1. Applies to 3 and 10 meter measurement distances
2. Applies to all valid combinations of Transducers (i.e. LISNs, Line Voltage Probes, and Antennas, as appropriate)
3. Excludes the Repeatability of the EUT

3. Practical Explanation of the Meaning of Radiated Emissions Measurement Uncertainties

In general, a “Statement of Measurement Uncertainty” means that with a certain (specified) confidence level, the “true” value of a measurand will be between a (stated) upper bound and a (stated) lower bound.

In the specific case of EMC Measurements in this test report, the measurement uncertainties of the conducted emissions measurements and the radiated emissions measurements have been calculated in accordance with the method detailed in the following documents:

- *ISO Guide to the Expression of Uncertainty in Measurement* (ISO, 1993)
- NIS 81:1994, *The Treatment of Uncertainty in EMC Measurements* (NAMAS, 1994)
- NIST Technical Note 1297(1994), *Guidelines for Evaluating and Expressing the Uncertainty of NIST Measurement Results* (NIST, 1994)

The calculation method used in these documents requires that the stated uncertainty of the measurements be expressed as an “*expanded uncertainty*”, U , with a $k=2$ coverage factor. The practical interpretation of this method of expressing measurement uncertainty is shown in the following example:

EXAMPLE: Assume that at 39.51 MHz, the (measured) radiated emissions level was equal to +26.5 dBuV/m, and that the +/- 2 standard deviations (i.e. 95% confidence level) measurement uncertainty was +/- 3.4 dB.

In the example above, the phrase “ $k = 2$ Coverage Factor” simply means that the measurement uncertainty is stated to cover +/-2 standard deviations (i.e. a 95% confidence interval) about the measurand. The measurand is the radiated emissions measurement of +26.5 dBuV/m at 39.51 MHz, and the 95% bounds for the uncertainty are -3.4 dB to + 3.4 dB. One can thus be 95% confident that the “true” value of the radiated emissions measurement is between +23.1 dBuV/m and +29.5 dBuV/m. *In effect, this means that in the above example there is only a 2.5% chance that the “true” radiated emissions value exceeds +29.5 dBuV/m.*

APPENDIX B

B. Nemko USA, Inc.'s Test Equipment & Facilities Calibration Program

Nemko USA, Inc. operates a comprehensive Periodic Calibration Program in order to ensure the validity of all test data. Nemko USA's Periodic Calibration Program is fully compliant to the requirements of NVLAP Policy Guide PG-1-1988, ANSI/NCSL Z540-1 (1994), ISO 10012-1 (1993-05-01), ISO Standard 17025, ISO-9000 and EN 45001. Nemko USA, Inc.'s calibrations program therefore meets or exceed the US national commercial and military requirements [N.B. ANSI/NCSL Z540-1 (1994) replaces MIL-STD-45662A].

Specifically, all of Nemko USA's *primary reference standard devices* (e.g. vector voltmeters, multimeters, attenuators and terminations, RF power meters and their detector heads, oscilloscope mainframes and plug-ins, spectrum analyzers, RF preselectors, quasi-peak adapters, interference analyzers, impulse generators, signal generators and pulse/function generators, field-strength meters and their detector heads, etc.) and certain *secondary standard devices* (e.g. RF Preamplifiers used in CISPR 11/22 and FCC Part 15/18 tests) are periodically recalibrated by:

- A Nemko USA-approved independent (third party) metrology laboratory that uses NIST-traceable standards and that is ISO Guide 25-accredited as a calibration laboratories by NIST; or,
- A Nemko USA-approved independent (third party) metrology laboratory that uses NIST-traceable standards and that is ISO Guide 25-accredited as a calibration laboratory by another accreditation body (such as A2LA) that is mutually recognized by NIST; or,
- A manufacturer of Measurement and Test Equipment (M&TE), if the manufacturer uses NIST-traceable standards and is ISO Guide 25-accredited as calibration laboratory either by NIST or by another accreditation body (such as A2LA) that is mutually recognized by NIST; or
- A manufacturer of M&TE (or by a Nemko USA-approved independent third party metrology laboratory) that is not ISO Guide 25-accredited. (In these cases, Nemko USA conducts an annual audit of the manufacturer or metrology laboratory for the purposes of proving traceability to NIST, ensuring that adequate and repeatable calibration procedures are being applied, and verifying conformity with the other requirements of ISO Guide 25).

In all cases, the entity performing the Calibration is required to furnish Nemko USA with a calibration test report and/or certificate of calibration, and a “calibration sticker” on each item of M&TE that is successfully calibrated.

Calibration intervals are normally one year, except when the manufacture advises a shorter interval (e.g. the HP 8568B Spectrum Analyzer is recalibrated every six months) or if US Government directives or client requirements demand a shorter interval. Items of instrumentation/related equipment which fail during routine use, or which suffer visible mechanical damage (during use or while in transit), are sidelined pending repair and recalibration. (Repairs are carried out either in-house [if minor] or by a Nemko USA-approved independent [third party] metrology laboratory, or by the manufacturer of the item of M&TE).

Each antenna used for CISPR 11 and CISPR 22 and FCC Part 15 and Part 18 radiated emissions testing (and for testing to the equivalent European Norms) is calibrated annually by either a NIST (or A2LA) ISO Standard 17025-Accredited third-party Antenna Calibration Laboratory or by the antenna’s OEM if the OEM is NIST or A2LA ISO Standard 17025-accredited as an antenna calibration laboratory. The antenna calibrations are performed using the methods specified in Annex G.5 of CISPR 16-1(1993) or ANSI C63.5-1991, including the “Three-Antenna Method”. Certain other kinds of antennas (e.g. magnetic-shielded loop antennas) are calibrated annually by either a NIST (or A2LA) ISO Standard 17025-accredited third-party antenna calibration laboratory, or by the antenna’s OEM if the OEM is NIST or A2LA ISO Standard 17025-accredited as an antenna calibration laboratory using the procedures specified in the latest version of SAE ARP-958.

In accordance with FCC and other regulations, Nemko USA recalibrates its suite of antennas used for radiated emissions tests on an annual basis. These calibrations are performed as a precursor to the FCC-required annual revalidation of the Normalized Site Attenuation properties of Nemko USA’s Open Area Test Site. Nemko USA, Inc. uses the procedures given in both Subclause 16.6 and Annex G.2 of CISPR 16-1 (1993), and, ANSI C63.4-1992 when performing the normalized site attenuation measurements.

APPENDIX C C. FCC and NVLAP Accreditation

United States Department of Commerce
National Institute of Standards and Technology



Certificate of Accreditation

ISO/IEC 17025:1999
ISO 9002:1994



NEMKO USA, INC. - SAN DIEGO EMC DIVISION
SAN DIEGO, CA

*is recognized by the National Voluntary Laboratory Accreditation Program
for satisfactory compliance with criteria set forth in NIST Handbook 150:2001,
all requirements of ISO/IEC 17025:1999, and relevant requirements of ISO 9002:1994.
Accreditation is awarded for specific services, listed on the Scope of Accreditation, for:*

ELECTROMAGNETIC COMPATIBILITY AND TELECOMMUNICATIONS

December 31, 2005

*For the National Institute of Standards and Technology
NVLAP Lab Code: 200116-0*

Effective through

National Institute
of Standards and Technology



National Voluntary
Laboratory Accreditation Program

ISO/IEC 17025:1999
ISO 9002:1994

Scope of Accreditation



Page: 1 of 3

**ELECTROMAGNETIC COMPATIBILITY
AND TELECOMMUNICATIONS**

NVLAP LAB CODE 200116-0

NEMKO USA, INC. - SAN DIEGO EMC DIVISION

11696 Sorrento Valley Road, Suite F

San Diego, CA 92121

Mr. Ricky Hill

Phone: 858-755-5525 x207 Fax: 858-793-9914

E-Mail: rick.hill@nemko.com

URL: <http://www.nemko.com>

NVLAP Code Designation / Description

Emissions Test Methods:

12/CIS14	CISPR 14-1 (March 30, 2000): Limits and Methods of Measurement of Radio interference Characteristics of Household Electrical Appliances, Portable Tools and Similar Electrical Apparatus - Part 1: Emissions
12/CIS14a	EN 55014-1 (1993), A1 (1997), A2 (1999):
12/CIS14b	AS/NZS 1044 (1995):
12/CIS14c	CNS 13783-1: Electromagnetic Compatibility Requirements for household appliances, electric tools and similar apparatus - Part 1: Emissions
12/CIS22	IEC/CISPR 22 (1997) & EN 55022 (1998) + A1(2000): Limits and methods of measurement of radio disturbance characteristics of information technology equipment
12/CIS22a	IEC/CISPR 22 (1993) and EN 55022 (1994): Limits and methods of measurement of radio disturbance characteristics of information technology equipment, Amendment 1 (1995) and Amendment 2 (1996)

December 31, 2005

Effective through

For the National Institute of Standards and Technology



ISO/IEC 17025:1999
ISO 9002:1994

Scope of Accreditation



Page: 2 of 3

**ELECTROMAGNETIC COMPATIBILITY
AND TELECOMMUNICATIONS**

NVLAP LAB CODE 200116-0

NEMKO USA, INC. - SAN DIEGO EMC DIVISION

<i>NVLAP Code</i>	<i>Designation / Description</i>
12/CIS22b	CNS 13438 (1997): Limits and Methods of Measurement of Radio Interference Characteristics of Information Technology Equipment
12/EM02a	IEC 61000-3-2, Edition 2.1 (2001-10), EN 61000-3-2 (2000), and AS/NZS 2279.1 (2000): Electromagnetic compatibility (EMC) Part 3-2: Limits - Limits for harmonic current emissions (equipment input current ≤ 16 A)
12/EM03b	IEC 61000-3-3, Edition 1.1(2002-03) & EN 61000-3-3, A1(2001): EMC - Part 3-3: Limits - Limitations of voltage changes, voltage fluctuations and flicker, in public low-voltage supply-systems, for equipment with rated current ≤ 16 A per phase and not subject to conditional connections
12/F18	FCC OST/MP-5 (1986): FCC Methods of Measurement of Radio Noise Emissions for ISM Equipment (cited in FCC Method 47 CFR Part 18 - Industrial, Scientific, and Medical Equipment)
12/FCC15b	ANSI C63.4 (2001) with FCC Method 47 CFR Part 15, Subpart B: Unintentional Radiators
12/T51	AS/NZS CISPR 22 (2002) and AS/NZS 3548 (1997): Electromagnetic Interference - Limits and Methods of Measurement of Information Technology Equipment

December 31, 2005

Effective through

For the National Institute of Standards and Technology

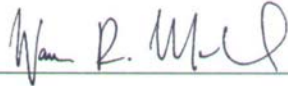
<p style="font-size: 2em; margin: 0;">NVLAP[®]</p> <p style="font-size: 0.8em; margin: 0;">National Institute of Standards and Technology</p>	<p style="font-size: 2em; margin: 0;">NVLAP[®]</p> <p style="font-size: 0.8em; margin: 0;">National Voluntary Laboratory Accreditation Program</p>	
<p>ISO/IEC 17025:1999 ISO 9002:1994</p>	<h2 style="margin: 0;">Scope of Accreditation</h2>	
		<p>Page: 3 of 3</p>
<p>ELECTROMAGNETIC COMPATIBILITY AND TELECOMMUNICATIONS</p>		<p>NVLAP LAB CODE 200116-0</p>
<p>NEMKO USA, INC. - SAN DIEGO EMC DIVISION</p>		
<p><i>NVLAP Code Designation / Description</i></p>		
<p>Immunity Test Methods:</p>		
<p>12/I01</p>	<p>IEC 61000-4-2, Ed. 2.1 (2001), A1, A2; EN 61000-4-2: Electrostatic Discharge Immunity Test</p>	
<p>12/I02</p>	<p>IEC 61000-4-3, Ed. 2.0 (2002-03); EN 61000-4-3 (2002): Radiated Radio-Frequency Electromagnetic Field Immunity Test</p>	
<p>12/I03</p>	<p>IEC 61000-4-4(1995), A1(2000), A2(2001); EN 61000-4-4: Electromagnetic compatibility (EMC) - Part 4-4: Testing and measurement techniques - Electrical Fast Transient/Burst Immunity Test</p>	
<p>12/I04</p>	<p>IEC 61000-4-5, Ed. 1.1 (2001-04); EN 61000-4-5: Electromagnetic compatibility (EMC) - Part 4-5: Testing and measurement techniques - Surge immunity test</p>	
<p>12/I05</p>	<p>IEC 61000-4-6, Ed. 2.0 (2003-05); EN 61000-4-6: Electromagnetic compatibility (EMC) - Part 4-6: Testing and measurement techniques - Immunity to conducted disturbances, induced by radio-frequency fields</p>	
<p>12/I06</p>	<p>IEC 61000-4-8, Ed. 1.1 (2001); EN 61000-4-8: Electromagnetic compatibility (EMC) - Part 4-8: Testing and measurement techniques - Power frequency magnetic field immunity test</p>	
<p>12/I07</p>	<p>IEC 61000-4-11, Ed. 1.1 (2001-03); EN 61000-4-11: Voltage Dips, Short Interruptions and Voltage Variations Immunity Tests</p>	
<p>December 31, 2005</p> <hr style="width: 50%; margin: 0 auto;"/> <p style="font-size: 0.8em;">Effective through</p>		 <hr style="width: 50%; margin: 0 auto;"/> <p style="font-size: 0.8em;">For the National Institute of Standards and Technology</p>