

Hearing Aid Compatibility

FCC 47 CFR section 20.19 Test Report

Dual-Band Dual-Mode CDMA Cellular Phone	
FCC ID:	OVFKWC-K27
Model:	K132

STATEMENT OF CERTIFICATION			
<p><i>The data, data evaluation and equipment configuration represented herein are a true and accurate representation of the measurements of the sample's HAC RF emissions characteristics as of the dates and at the times of the test under the conditions herein specified.</i></p>			
STATEMENT OF COMPLIANCE			
<p><i>This product was tested in accordance with the measurement procedures specified in ANSI C63.19-2005 and has been shown to be capable of compliance with the technical requirements of FCC 47 CFR section 20.19.</i></p>			
Test Location:	Kyocera Wireless Corp. 10300 Campus Point Drive, San Diego, CA 92121 USA		
Test performed by:	Yohannes Ghebrehwet Test Technician	Date of Test:	8/18/06 – 8/22/06
Report Prepared by:	Yohannes Ghebrehwet Test Technician	Date of Report:	8/24/06 – 8/24/06
Report Reviewed by:	C. K. Li Hardware Engineer, Senior Staff/Manager	Date of Review:	8/24/06

TABLE OF CONTENTS

1	Introduction.....	3
2	Equipment Under Test (EUT)	3
3	Summary of Test Results.....	3
4	Test conditions.....	4
4.1	Ambient Conditions	4
4.2	RF characteristics of the test site.....	4
4.3	Test Signal, Frequencies and Output Power	4
4.4	EUT Operating Conditions.....	5
5	Description of the test equipment	5
5.1	Test Equipment Used.....	5
5.2	Near Field Measurement System	6
5.3	Isotropic E-Field Probe	6
5.4	Isotropic H-Field Probe	7
6	System Validation.....	8
7	Description Of The Test Procedure	9
7.1	Test Positions	9
7.2	RF Emission Measurements Reference and Plane.....	9
7.3	RF Emissions Measurement Procedures	10
7.4	Probe Modulation Factor (PMF).....	11
7.4.1	Measurement Procedures	11
7.4.2	PMF Test Results	12
7.4.3	PMF Peak Power Measurement Plots.....	13
8	Emission Data Extraction and Post processing.....	16
9	Measurement Uncertainty	17
10	RF Emissions Tests.....	18
10.1	Emission Limits.....	18
10.2	CDMA 1900 Test Results	19
10.3	CDMA 800 Test Results	20
10.4	Worst-Case Configuration Evaluation	21
10.4.1	Peak Reading 360° Probe Rotation at Azimuth axis.....	21
11	Appendix A: Probe Calibration Certification.....	22
12	Appendix B: System Validation Plots.....	24
13	Appendix C: Test Results/Plots.....	24
14	Appendix D: Photo Test Setup	24

1 Introduction

This test report describes the Hearing Aid Compatibility (HAC) measurement of a wireless portable device manufactured by Kyocera Wireless Corp. (KWC). These measurements were performed for compliance with the rules and regulations of the U.S. Federal Communications Commission (FCC). The testing was performed in accordance with ANSI C63.19-2005.

This report covers test and data on:

X	RF Emissions	ANSI C63.19 Clause 4
	T-Coil	ANSI C63.19 Clause 6

2 Equipment Under Test (EUT)

Product:	Dual-Band Dual-mode CDMA Cellular Phone	
FCC ID:	OVFKWC-K27	
Model Number:	K132	
EUT Serial Number:	BCDX	
Type:	[] Prototype, [X] Pre-Production, [] Production	
Device Category:	Portable	
RF Exposure Environment:	General Population / Uncontrolled	
Antenna:	Internal Monopole	
Detachable Antenna:	No	
External Input:	Audio/Digital Data	
Quantity:	Quantity production is planned	
Modes:	800 CDMA	1900 CDMA
Multiple Access Scheme:	CDMA	CDMA
TX Frequency (MHz):	824 – 849	1850 - 1910
Rated RF Conducted Output Power (dBm)	25.0 Phone	22.7 Phone

3 Summary of Test Results

ANSI C63.19 (2005)		
Section 4 RF Emissions		
Test	Test Results	Overall Category
E-Field Emissions	M3	M3
H-Field Emissions	M4	

4 Test conditions

4.1 Ambient Conditions

All tests were performed under the following environmental conditions:

Ambient Temperature:	23 ± 2 Degrees C
Tissue simulating liquid temperature:	22 ± 1 Degrees C
Relative Humidity (RH):	0% <RH < 80%
Atmospheric Pressure:	101.3kPa + 10 to -5kPa

4.2 RF characteristics of the test site

All HAC measurements were performed inside a shielded room that provide isolation from external EM fields, with the RF ambient at least 20 dB below the intended measurement limits.

4.3 Test Signal, Frequencies and Output Power

Peak and Average conducted power were measured for each mode for comparison. RC3 SO55 was chosen for worst case power configuration.

CONFIGURATION	CONDUCTED POWER			
	CDMA 800 (ch 383)		CDMA 1900 (ch 1175)	
	Peak (dBm)	Average (dBm)	Peak (dBm)	Average (dBm)
RC1, SO2, Full Rate	28.90	24.74	27.06	22.49
RC1, SO55, Full Rate	28.89	24.77	26.96	22.51
RC2, SO9, Full Rate	28.84	24.75	26.81	22.49
RC2, SO55, Full Rate	28.73	24.78	27.03	22.48
RC3, SO2, Full Rate	28.48	24.73	26.77	22.46
RC3, SO55, Full Rate	28.96	24.79	27.07	22.53
RC43, SO2, Full Rate	28.43	24.72	26.79	22.50
RC43, SO55, Full Rate	28.25	24.60	26.76	22.49
RC54, SO9, Full Rate	28.77	24.71	26.69	22.48
RC54, SO55, Full Rate	28.75	24.68	26.72	22.51
RC3, SO32, (+ F-SCH) Full Rate	28.78	24.70	26.79	22.52
RC3, SO32, (+ SCH) Full Rate	28.86	24.72	26.70	22.51

During tests, the EUT was put in in-call mode and controlled by a CDMA simulator to generate the required signal and power using the configuration below.

Protocol:	6 (IS-2000)
Radio Configuration:	3
Power Control:	All Up Bits
Service Option:	55
Data Rate:	Full

In all operating modes, the phone was set to rate maximum RF power level and the measurements were performed on low, mid and high channels.

The measurement system measures power drift during HAC testing by comparing E/H-field in the same location at the beginning and at the end of measurement. These records were used to monitor stability of power output during tests. Conducted RF power measurements were also performed before and after each HAC measurements to confirm the output power.

4.4 EUT Operating Conditions

The EUT was tested with the following configurations and conditions, if applicable:

<input checked="" type="checkbox"/>	Fully charged standard as supplied with the handset
<input checked="" type="checkbox"/>	Open configuration, at ear use position.
<input type="checkbox"/>	Both retracted and extended antenna positions
<input checked="" type="checkbox"/>	Back-light tested ON and OFF
<input type="checkbox"/>	Simultaneous transmission with Bluetooth transmitter ON

5 Description of the test equipment

5.1 Test Equipment Used

Below is a list of the calibrated equipment used for the measurements:

Description	Manufacturer	Model Number	Serial Number	Cal Due Date
Power Meter	Giga-tronics	8541C	1830971	05/17/07
Signal Generator	Hewlett Packard	E4421B	US38440337	06/20/07
Radio Communication Tester	Agilent	8960	US40480198	04/20/08
Data Acq	Speag	DAE4	530	01/16/07
E-field Probe	Speag	ER3DV6	2282	10/21/06
H-field Probe	Speag	H3DV5	6123	09/23/06
Dipole Antenna (835MHz)	Speag	CD835V3	1020	04/27/07
Dipole Antenna (1880MHz)	Speag	CD1880V3	1015	04/05/07
Spectrum Analyzer	Hewlett Packard	8594E	3543H02438	04/13/07

The calibration certificates of E-field and H-field probes are attached in Appendix A.

5.2 Near Field Measurement System

The measurements were performed with Dasy4 automated near-field scanning system comprised of high precision robot, robot controller, computer, near-field probe, probe alignment sensor, non-conductive phone positioner, Test Arch and software extension. The overall expanded uncertainty (K=2) of the measurement system is $\pm 10.9\%$ and $\pm 14.7\%$ for H-field and E-field resp. The measurement uncertainty budget is given in section 6.

5.3 Isotropic E-Field Probe

Model	<ul style="list-style-type: none"> ▪ ER3DV6
Construction	<ul style="list-style-type: none"> ▪ One dipole parallel, two dipoles normal to probe axis ▪ Built-in shielding against static charges ▪ PEEK enclosure material (resistant to organic solvents, e.g., glycoether)
Calibration	<ul style="list-style-type: none"> ▪ In air from 100 MHz to 3.0 GHz (absolute accuracy $\pm 6\%$; k=2)
Frequency	<ul style="list-style-type: none"> ▪ 100MHz to 6 GHz ▪ Linearity: $\pm 0.2\text{dB}$ (100MHz to 3GHz)
Directivity	<ul style="list-style-type: none"> ▪ $\pm 0.2\text{ dB}$ in air (rotation around probe axis) ▪ $\pm 0.4\text{ dB}$ in air (rotation normal to probe axis)
Dynamic Range	<ul style="list-style-type: none"> ▪ 2 V/m to > 1000 V/m ▪ Linearity: $\pm 0.2\text{ dB}$
Dimensions	<ul style="list-style-type: none"> ▪ Overall length: 330 mm (Tip: 16 mm) ▪ Tip diameter: 8 mm (Body: 12 mm) ▪ Distance from probe tip to dipole centers: 2.5 mm
Application	<ul style="list-style-type: none"> ▪ General near-field measurements up to 6 GHz ▪ Field component measurements ▪ Fast automatic scanning in phantoms

5.4 Isotropic H-Field Probe

Model	<ul style="list-style-type: none"> ▪ H3DV5
Construction	<ul style="list-style-type: none"> ▪ Three concentric loop sensors with 3.8 mm loop diameters ▪ Resistively loaded detector diodes for linear response ▪ Built-in shielding against static charges ▪ PEEK enclosure material (resistant to organic solvents, e.g., glycolether)
Frequency	<ul style="list-style-type: none"> ▪ 200 MHz to 3 GHz ($\pm 6.0\%$, $k=2$); Output linearized
Directivity	<ul style="list-style-type: none"> ▪ ± 0.25 dB (spherical isotropy error)
Dynamic Range	<ul style="list-style-type: none"> ▪ 10 mA/m to 2 A/m at 1 GHz
E-Field Interference	<ul style="list-style-type: none"> ▪ $< 10\%$ at 3 GHz (for plane wave)
Dimensions	<ul style="list-style-type: none"> ▪ Overall length: 330 mm (Tip: 40 mm) ▪ Tip diameter: 6 mm (Body: 12 mm) ▪ Distance from probe tip to dipole centers: 3 mm
Application	<ul style="list-style-type: none"> ▪ General magnetic near-field measurements up to 3 GHz ▪ Field component measurements ▪ Surface current measurements ▪ Measurements in air or liquids ▪ Low interaction with the measured field

6 System Validation

The manufacturer calibrates the probes annually. The HAC measurements of the device were done within 24 hours of system accuracy verification, which was done using calibration dipoles. Unmodulated continuous wave of power level of 20dBm was supplied to a dipole antenna placed under Test Arch. The measurement probes are positioned over the illuminated dipole at 10mm distance from the top surface of the dipole element to the calibration reference point of the sensor, defined by the probe manufacturer.

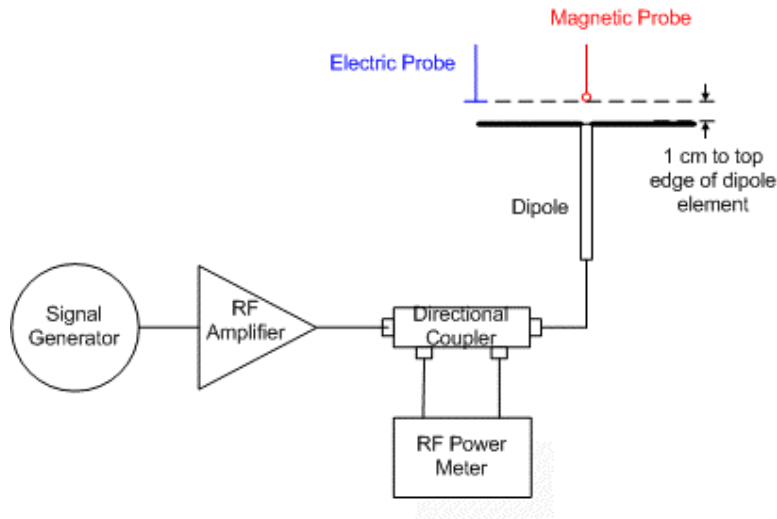

Figure 6 - System Check Setup

The length of the dipole was scanned with both E and H-field probes and the maximum values for each were recorded. The validation results are in the table below and printouts of the validation test are attached in Appendix B. All the measured parameters were within the specification.

Freq. (MHz)	Parameter	Target, SPEAG	Measured	Delta (%)	Limit (%)	Test date
836.49	E dB(V/m)	166.4	182.7	9.8	± 25	8/18/06
	H dB(A/m)	0.450	0.4708	4.62	± 25	8/18/06
	E dB(V/m)	166.4	169.9	2.1	± 25	8/21/06
	H dB(A/m)	0.450	0.4852	7.8	± 25	8/21/06
1880	E dB(V/m)	140.0	153.5	9.64	± 25	8/18/06
	H dB(A/m)	0.458	0.4818	5.2	± 25	8/18/06
	E dB(V/m)	140.0	143.3	2.36	± 25	8/21/06
	H dB(A/m)	0.458	0.4834	5.55	± 25	8/21/06

7 Description Of The Test Procedure

The device was positioned and setup according to ANSI C63.19-2005.

7.1 Test Positions

The device was placed on a non-conductive phone positioner under the Test Arch.

7.2 RF Emission Measurements Reference and Plane

Figure 7.2 illustrates the references and reference plane that shall be used in the EUT emissions measurement:

- The grid is 5 cm by 5 cm area that is divided into 9 evenly sized blocks or sub-grids.
- The grid is centered on the audio frequency output transducer (speaker) of the EUT.
- The grid is in a reference plane, which is defined as the planar area that contains the highest point in the area of the phone that normally rests against the user's ear. It is parallel to the centerline of the receiver of the EUT and is defined by the points of the receiver-end of the EUT, which, in normal handset use, rest against the ear.
- The measurement plane is parallel to, and 1.0 cm in front of, the reference plane.

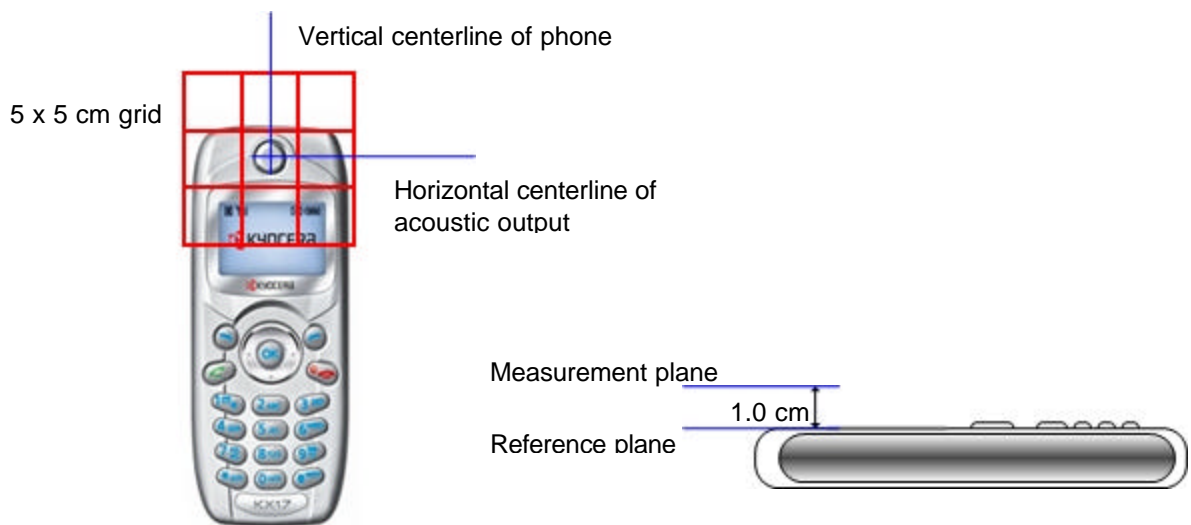

Figure 7.2 – Measurement Reference and Plane

7.3 RF Emissions Measurement Procedures

Figure 7.6 shows the near field emission measurement flowchart:

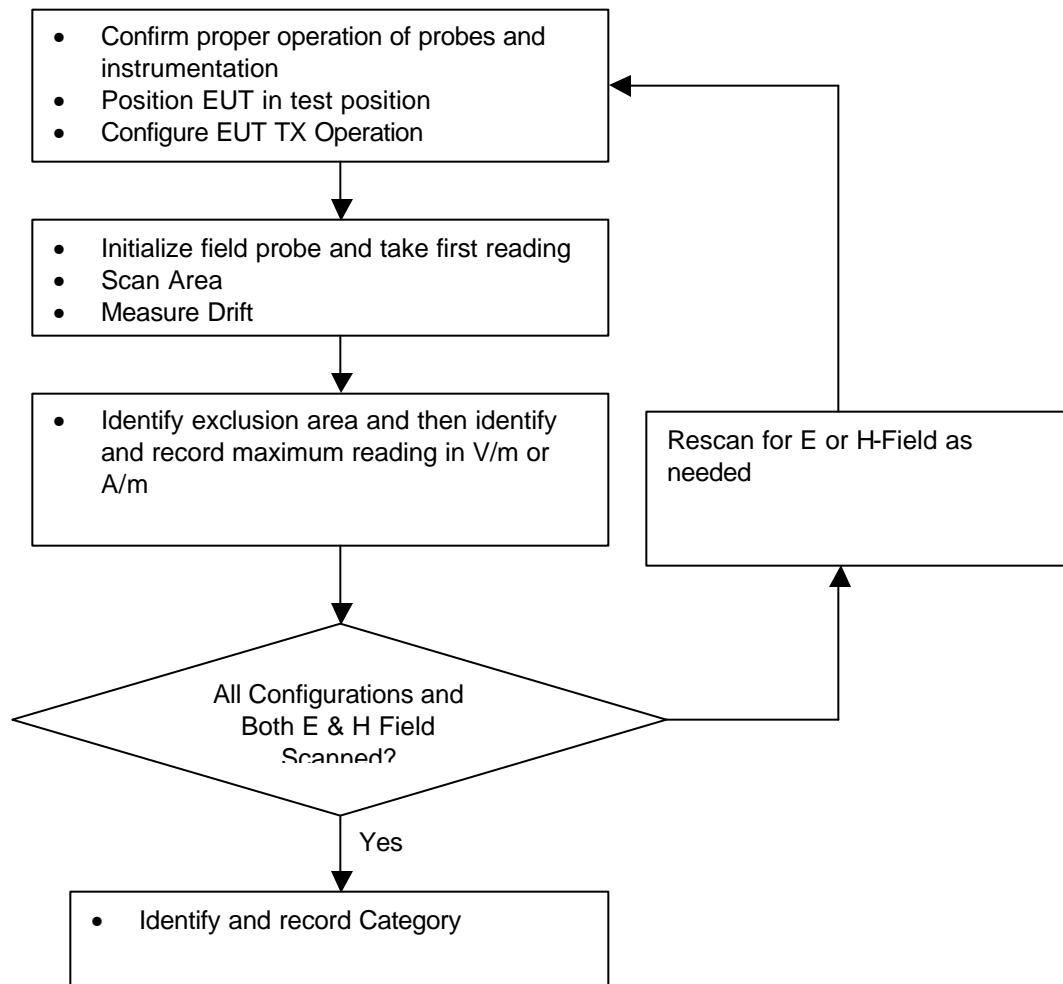

Figure 7.3 - Near field emission measurement flowchart

1. The center of the probe was scanning to the edges of the grid. Accordingly the total area covered by the outside edge of the probe was the 5 cm by 5 cm area, increased by half (½) the probe diameter on all sides.
2. The nearest point on the probe measurement element(s) was held 1.0 cm from the EUT reference plane.
3. The probe element is that portion of the probe that is designed to receive and sense the field being measured.
4. The physical body of the probe housing was not used when setting this 1.0 cm distance as this would place the sensing elements at an indeterminate distance from the reference plane.
5. The step size of the scan is set to 5 mm or less.
6. Up to three blocks were excluded for each field measurement.
 - The center block containing the EUT output was not excluded.
 - A maximum of five blocks were excluded for both E- and H-field measurements for the EUT output being measured. Stated differently, the center sub-grid or block and 3 other blocks were common to both the E- and H-field measurements for a given grid.

7.4 Probe Modulation Factor (PMF)

7.4.1 Measurement Procedures

A calibration was made of the modulation response of the probe and its instrumentation chain. This calibration was performed with the field probe, attached to its instrumentation. The response of the probe system to a CW field at the frequency of interest is compared to its response to a modulated signal with equal peak amplitude to that of a CW signal. The field level of the test signals shall be more than 10 dB above the ambient level and the noise floor of the instrumentation being used. The ratio of the CW reading to that taken with a modulated reading was applied to the DUT measurements. The measurement procedures are as following:

1. Fix the field probe in a set location relative to the dipole antenna, as illustrated in Figure 7.4.
2. Setup the wireless device (EUT) with intended signal at the intended measurement frequency.
3. Record the reading of the probe measurement system.
4. Replace the wireless device with a RF signal generator producing an unmodulated CW signal and set to the wireless device operating frequency.
5. Set the peak power of the unmodulated signal to equal that recorded from the wireless device
6. Record the reading of the probe measurement system of the unmodulated CW signal.
7. The ratio of probe reading (CW) in step 6 to the probe reading (EUT) in step 3 is the modulation factor.

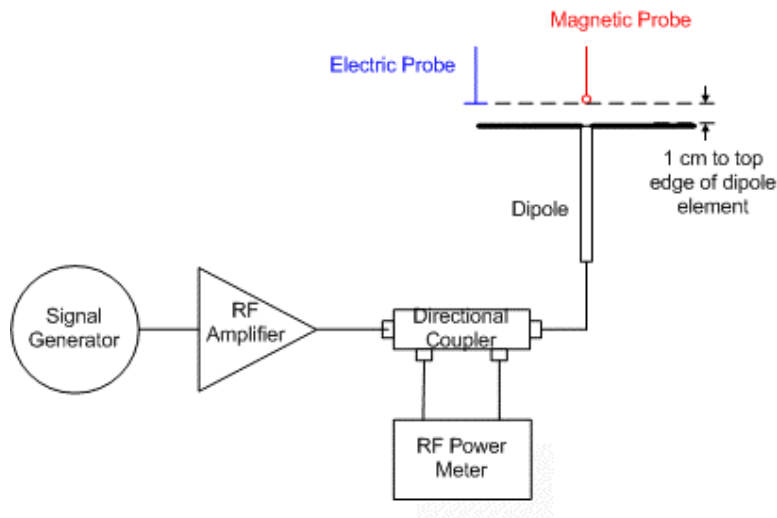

Figure 7.4 - Probe Modulation Setup

The modulation factors obtained by above method shall be applied to readings taken of the actual WD, in order to obtain an accurate peak field reading.

7.4.2 PMF Test Results

E-Field					
Frequency (MHz)	Peak Power (dBm)	Protocol	Protocol Reading (V/m)	PMF Ratio	PMF (dB)
836.49	24.75	CW	201.1		
	24.77	CDMA	197.9	1.02	0.1
	24.75	AM	131.6	1.53	3.7
1880	22.56	CW	96.66		
	22.52	CDMA	95.55	1.01	0.1
	22.56	AM	61.59	1.57	3.9
H-Field					
Frequency (MHz)	Peak Power (dBm)	Protocol	Protocol Reading (A/m)	PMF Ratio	PMF (dB)
836.49	24.77	CW	0.6253		
	24.79	CDMA	0.6163	1.01	0.1
	24.75	AM	0.4077	1.53	3.7
1880	22.53	CW	0.3501		
	22.51	CDMA	0.3575	0.98	-0.2
	22.52	AM	0.2255	1.55	3.8

7.4.3 PMF Peak Power Measurement Plots

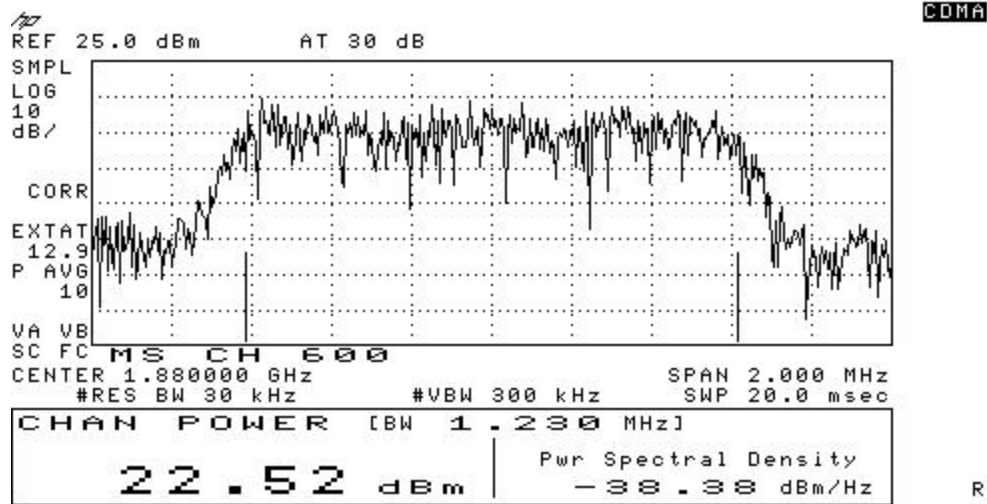

CDMA-1900

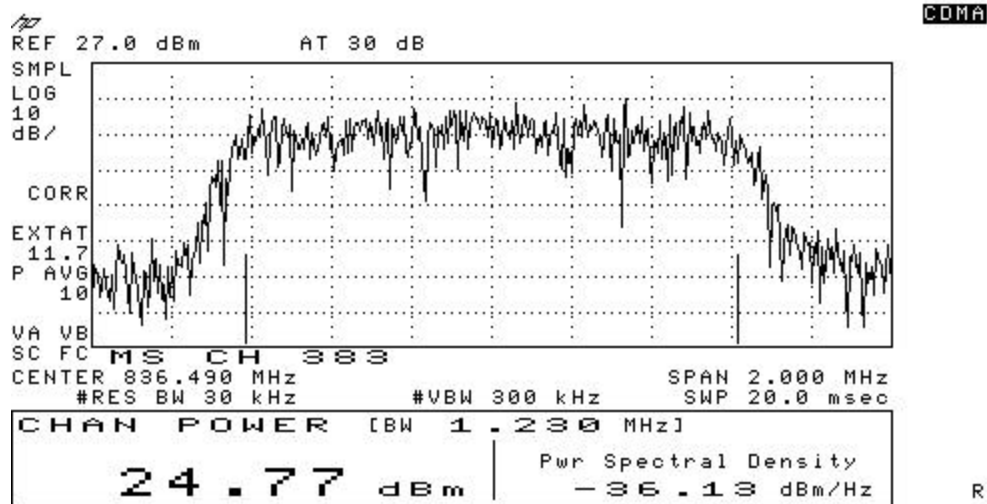

CDMA-800

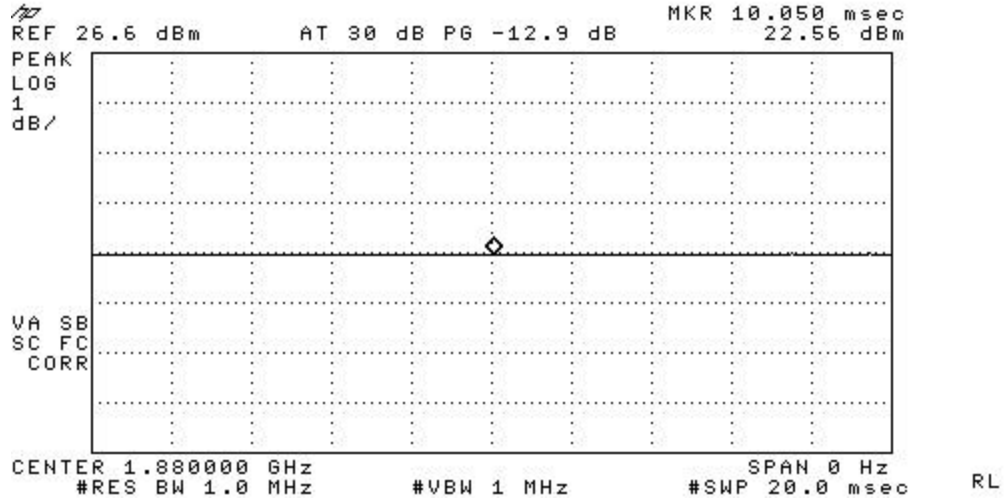

CW -1900

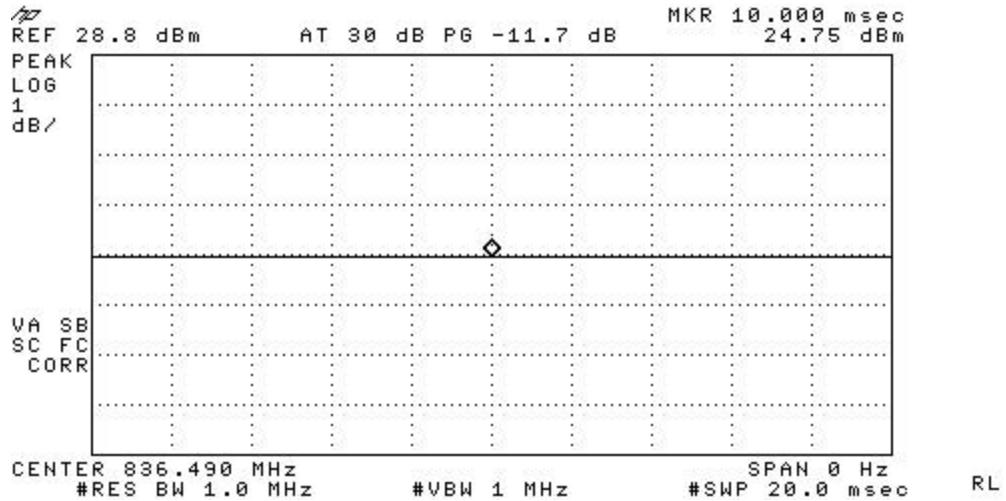

CW -800

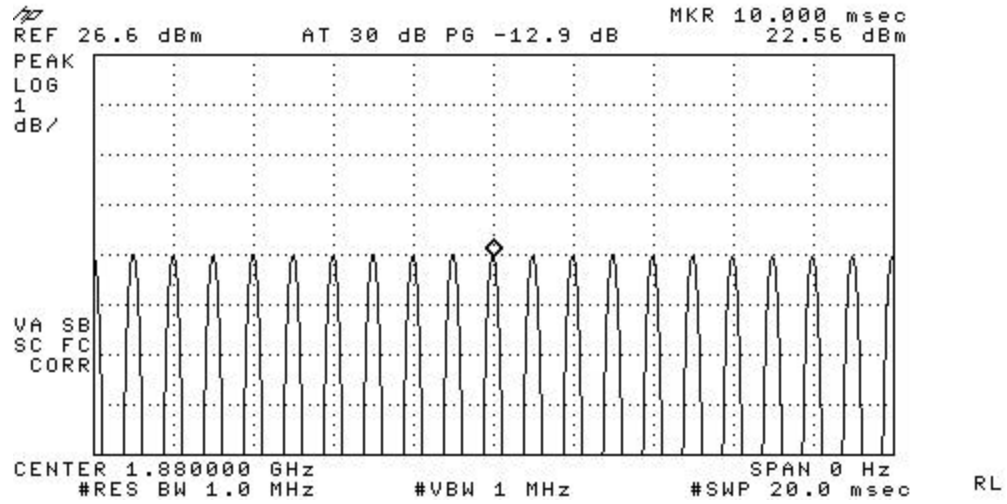

80% AM -1900

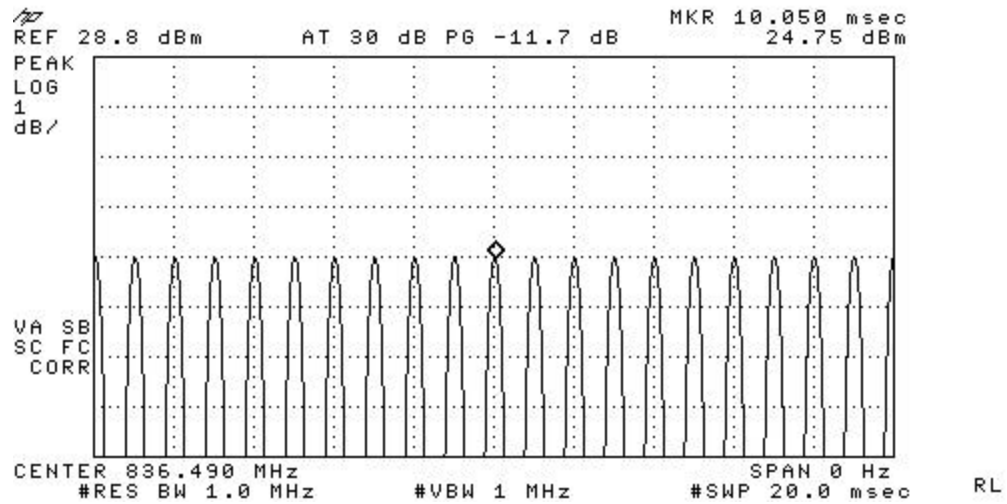

80% AM -800

8 Emission Data Extraction and Post processing

At the end of the measurements, the DASY4 system automatically evaluates the slot-averaged results, exclusion of the three highest sub-grid, application of the AWF factor per ANSI-C63.19 requirements.

The following AWF factors were used for the standard transmission protocols:

Standard	Technology	AWF
TIA/EIA/IS-2000	CDMA	0
TIA/EIA-136	TDMA (50 Hz)	0
J-STD-007	GSM (217)	-5
T1/T1P1/3GPP	UMTS (WCDMA)	0
iDEN™	TDMA(22 and 11 Hz)	0

Table 7.5a - Articulation Weighting Factor (AWF)

All DASY4 measurements are in RMS values. The DASY4 system incorporates the crest factor of the signal in the computation of the RMS values. Although the software also has the capability to estimate the peak field by applying a square root of the crest factor value to the readings, the probe modulation factor was applied manually instead per ANSI C63.19 in the measurement tables in this report using equation:

$$\text{Peak Field} = (\text{DASY4 reading}) \times \text{PMF}$$

where DASY4 reading = measurement from DASY4 in V/m or A/m
 PMF = Probe Modulation Factor in linear unit

9 Measurement Uncertainty

Table 9 shows the uncertainty budget for HAC free field assessment according to ANSI C63.19-2005. The budget is valid for the frequency range 800 MHz - 3 GHz and represents a worst-case analysis. For specific tests and configurations, the uncertainty could be smaller.

Uncertainty Description	Uncert. Value (\pm %)	Prob. Dist.	Div.	C _i (E)	C _i (H)	Stand. Uncert (E) (\pm %)	Stand. Uncert (H) (\pm %)
Measurement system							
Probe calibration	5.1	N	1	1	1	5.1	5.1
Axial isotropy of the probe	4.7	R	v3	1	1	2.7	2.7
Sensor displacement	16.5	R	v3	1	0.145	9.5	1.4
Boundary effects	2.4	R	v3	1	1	1.4	1.4
Probe linearity	4.7	R	v3	1	1	2.7	2.7
Scaling to Peak Envelope Power	2.0	R	v3	1	1	1.2	1.2
System Detection limit	1.0	R	v3	1	1	0.6	0.6
Readout electronics	0.3	N	1	1	1	0.3	0.3
Response time	0.8	R	v3	1	1	0.5	0.5
Integration time	2.6	R	v3	1	1	1.5	1.5
RF ambient conditions	3.0	R	v3	1	1	1.7	1.7
RF Reflections	12	R	v3	1	1	6.9	6.9
Probe Positioner	1.2	R	v3	1	0.67	0.7	0.5
Probe positioning	4.7	R	v3	1	0.67	2.7	1.8
Extrap. and integration	1.0	R	v3	1	1	0.6	0.6
Test Sample Related							
Device positioning vertical	4.7	R	v3	1	0.67	2.7	1.8
Device Positioning Lateral	1.0	R	v3	1	1	0.6	0.6
Device Holder and Phantom	2.4	R	v3	1	1	1.4	1.4
Power drift	5.0	R	v3	1	1	2.9	2.9
Phantom and Setup Related							
Phantom thickness	2.4	R	v3	1	0.67	1.4	0.9
Combined Standard Uncertainty:						14.7	10.9
Extended Standard Uncertainty on Power (k=2):						29.4	21.8
Extended Standard Uncertainty on Field (k=2):						14.7	10.9

N: Normal

R: Rectangular

Table 9 - Worst-Case uncertainty budget for HAC free field assessment

10 RF Emissions Tests

10.1 Emission Limits

Table 8.1 shows the M-rating criteria from ANSCI C63.19. All digital transmission modes in all frequency bands contained in a HAC phone must meet M3 or M4 levels.

Category	Wireless Device RF Parameters		
Near Field	AWF	E-Field Emissions dB(V/m) Peak	H-Field Emissions dB(A/m) Peak
M1	AWF = 0	46.0 to 51.0	-4.4 to 0.6
M2	AWF = 0	41.0 to 46.0	-9.4 to -4.4
M3	AWF = 0	36.0 to 41.0	-14.4 to -9.4
M4	AWF = 0	< 36.0	< -14.4

Table 10.1 - RF Emission Limits

10.2 CDMA 1900 Test Results

CDMA 1900 E-Field								
Configuration:		Open			Antenna		Internal	
Ch.	Backlight	Battery	Power before Test	Power after Test	Dasy4 Reading	PMF	Peak Field	Category
#			dBm	dBm	V/m		V/m	M
25	ON	Standard	22.44	22.40	39.90	1.00	39.90	4
600	ON	Standard	22.54	22.55	34.50	1.00	34.50	4
1175	ON	Standard	22.50	22.51	42.70	1.00	42.70	4
1175	OFF	Standard	22.50	22.51	44.30	1.00	44.30	4

Data plots are shown in Appendix C

CDMA 1900 H-Field								
Configuration:		Open			Antenna		Internal	
Ch.	Backlight	Battery	Power before Test	Power after Test	Dasy4 Reading	PMF	Peak Field	Category
#			dBm	dBm	A/m		A/m	M
25	ON	Standard	22.44	22.40	0.10	1.00	0.10	4
600	ON	Standard	22.54	22.55	0.10	1.00	0.10	4
1175	ON	Standard	22.50	22.51	0.11	1.00	0.11	4
1175	OFF	Standard	22.50	22.51	0.11	1.00	0.11	4

Data plots are shown in Appendix C

10.3 CDMA 800 Test Results

CDMA 800 E-Field								
Configuration:		Open			Antenna		Internal	
Ch.	Backlight	Battery	Power before Test	Power after Test	Dasy4 Reading	PMF	Peak Field	Category
#			dBm	dBm	V/m		V/m	M
1013	ON	Standard	24.71	24.78	51.20	1.00	51.20	4
383	ON	Standard	24.75	24.87	67.50	1.00	67.50	3
777	ON	Standard	24.60	24.68	67.20	1.00	67.20	3
383	OFF	Standard	24.75	24.87	71.00	1.00	71.00	3
777	OFF	Standard	24.60	24.68	70.50	1.00	70.50	3

Data plots are shown in Appendix C

CDMA 800 H-Field								
Configuration:		Open			Antenna		Internal	
Ch.	Backlight	Battery	Power before Test	Power after Test	Dasy4 Reading	PMF	Peak Field	Category
#			dBm	dBm	A/m		A/m	M
1013	ON	Standard	24.71	24.78	0.07	1.00	0.07	4
383	ON	Standard	24.75	24.87	0.08	1.00	0.08	4
777	ON	Standard	24.60	24.68	0.09	1.00	0.09	4
383	OFF	Standard	24.75	24.87	0.08	1.00	0.08	4
777	OFF	Standard	24.60	24.68	0.09	1.00	0.09	4

Data plots are shown in Appendix C

10.4 Worst-Case Configuration Evaluation

10.4.1 Peak Reading 360° Probe Rotation at Azimuth axis

The probe was rotated 360° in the worst case configuration. The rotation was performed at the location of maximum field strength in the included blocks.

CDMA 1900 E-Field							
Configuration: Open				Antenna: Internal			
Ch.	Backlight	Battery	Conducted Power	Peak Field	PMF	Peak Field	Category
#			dBm	V/m		V/m	M
1175	ON	Standard	22.5	42.00	1.0	42.00	4

CDMA 800 E-Field							
Configuration: Open				Antenna: Internal			
Ch.	Backlight	Battery	Conducted Power	Peak Field	PMF	Peak Field	Category
#			dBm	V/m		V/m	M
383	ON	Standard	25	66.20	1.0	66.20	3
777	ON	Standard	25	67.40	1.0	67.40	3

Data plots are shown in Appendix C

11 Appendix A: Probe Calibration Certification

**Calibration Laboratory of
Schmid & Partner
Engineering AG**
Zeughausstrasse 43, 8064 Zurich, Switzerland



S Schweizerischer Kalibrierdienst
S Service suisse d'étalonnage
C Servizio svizzero di taratura
S Swiss Calibration Service

Accredited by the Swiss Federal Office of Metrology and Accreditation
The Swiss Accreditation Service is one of the signatories to the EA
Multilateral Agreement for the recognition of calibration certificates

Accreditation No.: **SCS 108**

Client: **Kyocera USA**

Certificate No: **ER3-2282_Oct05**

CALIBRATION CERTIFICATE

Objekt: **ER3DV6 - SN:2282**

Calibration procedure(s): **QA CAL:02.v4
Calibration procedure for E-field probes optimized for close near field
Evaluations in air**

Calibration date: **October 21, 2005**

Condition of the calibrated item: **In Tolerance**

This calibration certificate documents the traceability to national standards, which realize the physical units of measurements (SI).
The measurements and the uncertainties with confidence probability are given on the following pages and are part of the certificate.

All calibrations have been conducted in the closed laboratory facility: environment temperature (22 ± 3)°C and humidity < 70%.

Calibration Equipment Used (M&PE critical for calibration)

Primary Standards	ID #	Cal Date (Calibrated by, Certificate No.)	Scheduled Calibration
Power meter E4415B	GB41292874	3-May-05 (METAS, No. 251-00466)	May-05
Power sensor E4412A	NY41486277	3-May-05 (METAS, No. 251-00466)	May-05
Power sensor E4412A	NY41488087	3-May-05 (METAS, No. 251-00466)	May-05
Reference 3 dB Attenuator	SN: 55054 (3c)	11-Aug-05 (METAS, No. 251-00466)	Aug-05
Reference 20 dB Attenuator	SN: 55086 (20b)	3-May-05 (METAS, No. 251-00467)	May-05
Reference 30 dB Attenuator	SN: 55129 (30b)	11-Aug-05 (METAS, No. 251-00500)	Aug-05
Reference Probe ER3DV6	SN: 2282	3-Oct-05 (SPEAG, No. ER3-2282_Oct05)	Oct-05
DAE4	SN: 654	29-Nov-04 (SPEAG, No. DAE4-654_Nov04)	Nov-05
Secondary Standards	ID #	Check Date (in house)	Scheduled Check
RF generator HP 8648C	US8642U01700	4-Aug-00 (SPEAG, in house check Dec-03)	In house check: Dec-05
Network Analyzer HP 8753B	US8739C685	18-Oct-01 (SPEAG, in house check Nov-04)	In house check: Nov-05

	Name	Function	Signature
Calibrated by:	Nico Vetter	Laboratory Technician	
Approved by:	Kate Pukovic	Technical Manager	

Issued: October 24, 2005

This calibration certificate shall not be reproduced except in full without written approval of the laboratory.

#039907

**Calibration Laboratory of
Schmid & Partner
Engineering AG**
Zeughausstrasse 43, 8004 Zurich, Switzerland



S Schweizerischer Kalibrierdienst
C Service suisse d'étalonnage
S Servizio svizzero di taratura
S Swiss Calibration Service

Accredited by the Swiss Federal Office of Metrology and Accreditation
The Swiss Accreditation Service is one of the signatories to the EA
Multilateral Agreement for the recognition of calibration certificates

Accreditation No.: **SCS 108**

Client **Kyocera USA**

Certificate No: **H3-6123_Sep05**

CALIBRATION CERTIFICATE

Object: **H3DV6 - SN:6123**

Calibration procedure(s): **QA CAL-03.v4
Calibration procedure for H-field probes optimized for close near field evaluations in air**

Calibration date: **September 23, 2005**

Condition of the calibrated item: **In Tolerance**

This calibration certificate documents the traceability to national standards, which realize the physical units of measurements (SI).
The measurements and the uncertainties with confidence probability are given on the following pages and are part of the certificate.

All calibrations have been conducted in the closed laboratory facility: environment temperature (22 ± 3)°C and humidity < 70%.

Calibration Equipment used (M&TE critical for calibration)

Primary Standards	ID #	Cal Date (Calibrated by, Certificate No.)	Scheduled Calibration
Power meter E4419B	GB41293874	3-May-05 (METAS, No. 251-00466)	May-06
Power sensor E4412A	MY41495277	3-May-05 (METAS, No. 251-00466)	May-06
Power sensor E4412A	MY41498087	3-May-05 (METAS, No. 251-00466)	May-06
Reference 3 dB Attenuator	SN: S5054 (3c)	11-Aug-05 (METAS, No. 251-00499)	Aug-06
Reference 20 dB Attenuator	SN: S5086 (20b)	3-May-05 (METAS, No. 251-00467)	May-06
Reference 30 dB Attenuator	SN: S5129 (30b)	11-Aug-05 (METAS, No. 251-00500)	Aug-06
Reference Probe H3DV6	SN: 6182	6-Oct-04 (SPEAG, No. H3-6182_Oct04)	Oct-05
DAE4	SN: 654	29-Nov-04 (SPEAG, No. DAE4-654_Nov04)	Nov-05
Secondary Standards	ID #	Check Date (in house)	Scheduled Check
RF generator HP 8648C	US3642U01700	4-Aug-99 (SPEAG, in house check Dec-03)	In house check: Dec-05
Network Analyzer HP 8753E	US37390585	18-Oct-01 (SPEAG, in house check Nov-04)	In house check: Nov 05

Calibrated by:	Name Nico Vetterli	Function Laboratory Technician	Signature
Approved by:	Name Katja Pokovic	Technical Manager	

Issued: September 26, 2005

This calibration certificate shall not be reproduced except in full without written approval of the laboratory.

12 Appendix B: System Validation Plots

(See attachment)

13 Appendix C: Test Results/Plots

(See attachment)

14 Appendix D: Photo Test Setup

(see attachment)