

Hearing Aid Compatibility (Audio)

Mobile Phone Dual-Band CDMA

Kyocera K323



July 2006

APREL Project No.: KYOB-K323-5239

51 Spectrum Way Nepean ON K2R 1E6
Tel: (613) 820-2730 Fax: (613) 820-4161
email: info@aprel.com

Engineering Report

Subject:

Assessment of Compliance with respect to
ANSI C63.19-2006/5
Hearing Aid Compatibility Audio

FCC ID: OVFKWC-K24B

Product: Mobile Phone, CDMA

Model: K323

Client: Kyocera Wireless
10300 Campus Point Drive
San Diego, CA 92121

Project #: KYOB-K323-5239

Prepared by: APREL Laboratories

Regulatory Compliance Division
51 Spectrum Way
Nepean, Ontario
K2R 1E6, Canada



SAR & HAC Instruments for Wireless • Consulting • Research • Standards • Compliance • Training

Applicant Name: Kyocera Wireless
Applicant Address: 10300 Campus Point Drive
 San Diego, CA 92121
Project Number: KYOB-K323-5239
Test/Analysis Date: 12 & 13 July 2006
Revision Date: 1st August 2006

DUT Type	Cellular Telephone
Project Name	K323
Received Status	Fully Functional
DUT Serial Number	Y-041106-SMT-01
Experimental/Compliance	Compliance ANSI-C63.19-2006/5
T category Cellular Band	4
T category PCS Band	4
FCC ID	OVFKWC-K24B

We the undersigned of APREL Laboratories, located at 51 Spectrum Way, Ottawa, Ontario, Canada, K2R-1E6, on the date indicated attest that the Device Under Test as detailed within this test report has been tested and found to be compliant with the ANSI-C63.19-2006/5 rules and regulations as defined by the methodologies, procedures, and standards as described in this document.

APREL Laboratories is an ISO 17025 accredited facility registered under Standards Council of Canada lab 48.

Prepared by: [Signature] Date: 21/08/2006
 Approved by: [Signature] Date: 1/8/2006
 Released by: [Signature] Date: Aug/06.



HAC Report Contents

Engineering Summary	5
Introduction	6
Standard	7
Test Equipment	7
Environmental Conditions	7
Product Information	8
Test System	9
Validation	17
TMFS Magnetic Dipole™ Application Note	23
General ALSAS 10U HAC System Description	26
Pre-Measurement Procedure	27
Test Procedure	30
Test Results System Validation	35
Test Results Kyocera DUT	40
Measurement Uncertainty	53
Additional Set-up pictures	54
Calibration Certificates	62

ENGINEERING SUMMARY

This report contains the results of the engineering evaluation performed on the KYOCERA mobile phone model K323. The analysis was carried out in accordance with the requirements of ANSI/IEEE C63.19-2006/5, "American National Standard for Methods of Measurement of Compatibility between Wireless Communications Devices and Hearing Aids"

KYOCERA provided APREL laboratories with one model of the Mobile Phone. The K323 Mobile Phone is hereby referred to as the DUT (Device Under Test).

The K323 Mobile Phone was evaluated for audio while engaged through an air interface d in both cellular and PCS bands.

In the **Cellular band**, the category for the telecoil evaluation is **T-4**.

In the **PCS band**, the category for the telecoil evaluation is **T-4**.

As such, the overall T category for the K323 is **T-4**.

Evaluation data and graphs are presented in this report.

This wireless portable device has been shown to be compatible in accordance with FCC rule 47 CFR 2.033(d) these test results demonstrate compliance with FCC 47CFR section 20.19 and with PC63.19 – 2006.

ANSI/IEEE C63.19 – 2006/5 HAC Rated Category: T-4

The results presented in this report relate only to the sample evaluated.

INTRODUCTION

General

HAC (Hearing Aid Compatibility) is an industry term introduced in the late 1970's to describe an audio frequency magnetic output of a wireline telephone for the purpose of making it possible to couple a telephone with a hearing aid. In the mid 1990's it was found that the required audio frequency magnetic field may not be usable if excessive RF interference is masking the audio signal. Therefore, new standards for wireless devices HAC, such as IEEE C63.19, which in addition to specification of the audio magnetic field for T-coil coupling also specify the allowable RF interference level for E-field and H-field as a function of hearing aid and RF susceptibility.

The purpose of the categorization (M and T etc.) is to establish categories for hearing aids and for telephones that can indicate to health care practitioners and hearing aid users which hearing aids are compatible with which telephone. Tests are performed to assess the electromagnetic characteristics of hearing aids and telephones and assign them to these categories. Telephones are tested for the E-field and H-field emissions along with the T-Coil magnetic output.

Measurement Facility

The evaluation for compliance was performed for Kyocera. by APREL Laboratories at APREL's EMI facility located in Nepean, Ontario, Canada.

Standard

The evaluation and analysis were conducted in accordance with **Hearing Aid Standard ANSI C63.19 2006**

Report: This report was written by Stuart Nicol, Director of Research and Development, based on test results supplied by Jesse Hones and Liguo Yang.

Test Equipment

The test equipment used during the evaluation is listed in this test report.

Environmental Conditions

- Temperature: 21 °C ± 2
- Relative Humidity: 30 - 50 %
- Air Pressure: 101 kPa ± 3

Product Information

FCC ID:	OVFKWC-K24B
EUT type:	Dual Band CDMA phone
Serial Number:	Y-041106-SMT-01
Prototype or Production:	Production Model
Mode of Operation:	CDMA, PCS
Tx Frequencies:	824.70-848.31 MKz (CDMA) 1851.25-1909.08 MHz (PCS)
Maximum Conducted RF Power (Nominal):	24dBm
FCC Classification:	Licensed Transmitter Held to Ear (PCE)

Battery

Type:	Lithium Ion
Part No./Model No.:	TXBAT 10106
Rated Capacity:	1000maH

Antenna

Type:	Integral
Location:	Top of Unit

Test System: Hearing Aid Compatibility (HAC)

The scanning and positioning requirements of HAC measurement performed by the ALSAS 10-U HAC system, the use of HAC specific hardware and software allows APREL to meet the existing ANSI C63.19 standard and its anticipated revisions. HAC testing utilizes E, H and T-Coil field probes. These probes are calibrated “in air” for scanning in air.



Axis Articulated Robot



ALSAS-10U utilizes a six axis articulated robot, which is controlled using a Pentium based real-time movement controller. The movement kinematics engine utilizes proprietary (Thermo CRS) interpolation and extrapolation algorithms, which allow full freedom of movement for each of the six joints within the working envelope. Utilization of joint 6 allows for full probe rotation with a tolerance better than 0.05mm around the central axis.

Robot/Controller Manufacturer	Thermo CRS
Number of Axis	Six independently controlled axis
Positioning Repeatability	0.05mm
Controller Type	Single phase Pentium based C500C
Robot Reach	710mm
Communication	RS232 and LAN compatible

Universal Device Positioner



The APREL Laboratories universal device positioner has been developed so as to allow complete freedom of movement of the DUT. Developed to hold a DUT in a free-space scenario any additional loading attributable to the material used in the construction of the positioner has been eliminated. Repeatability has been enhanced through the linear scales which form the design used to indicate positioning for any given test scenario in all major axes. A tilt indicator has been included for accurate positioning. Overall uncertainty for measurements have been reduced due to the design of the Universal device positioner, which allows positioning of a device in as near to a free-space scenario as possible, and by providing the means for complete repeatability.

Length	201mm
Width	140mm
Height	222mm
Weight	1.95kg
Number of Axis	6 axis freedom of movement
Translation Along MB Line	+/- 76.2mm
Translation Along NF Line	+/- 38.1mm
Translation Along Z Axis	+/- 25.4mm (expandable to 500mm)
Rotation Around MB Line (yaw)	+/- 10°
Rotation Around NF Line (pitch)	+/- 30°
Rotation Around Z Axis (roll)	360° full circle
Minimum Grip Range	0mm
Maximum Grip	152mm
Maximum Distance from Device to Positioner Material	40mm
Tilt Movement	Full movement with predefined 15° guide

The ALSAS-10U utilised the following probe for the T-Coil evaluation.

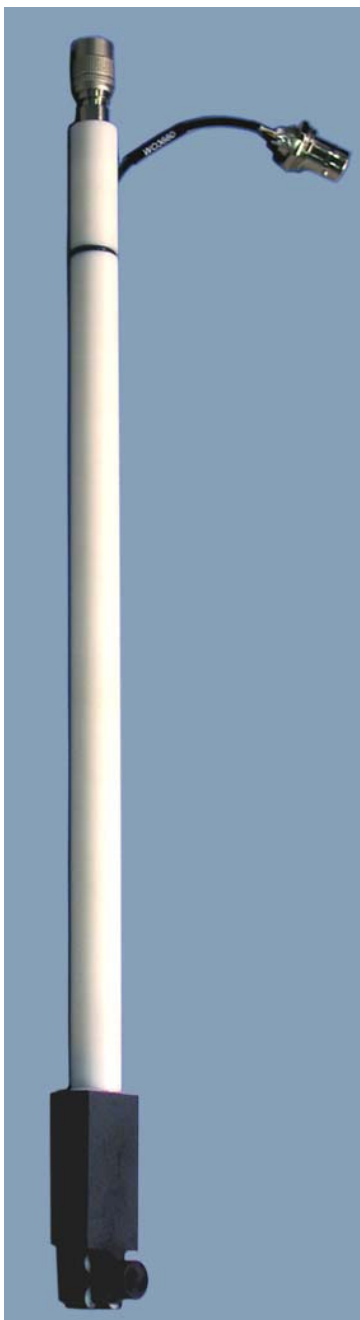

APREL T-Coil Probe Model: ALS-T-020

APREL Laboratories twin axis T-Coil Probe allows for accurate measurements of audio band magnetic field intensity in line with C63.19 200x requirements.

Part No.: ALS-T-Coil-TA-HAC

Features

-APREL Laboratories twin axis T-Coil field measurement probe is designed for the measurement of desired and undesired audio band magnetic field intensity (ABM) for wireless and wireline devices. Probe orientation is either axial (probe axis is parallel to the receiver earcap axis) or radial (probe coil axis is perpendicular to the receiver earcap axis).

-Accurately measures axial fields (-)

-Accurately measures radial fields (l)

-Accurately characterize the frequency response for signals measured across the audio band

Applications

- Compliance Testing to ANSI 63.19
- Compliance Testing to FCC requirements
- Validation of Hearing Aid Compatibility (HAC) automated test systems
- Research in the area of Hearing Aid Compatibility
- Design and Development of Hearing Aids
- Design and Development of handsets wireless and wireline to HAC standards.

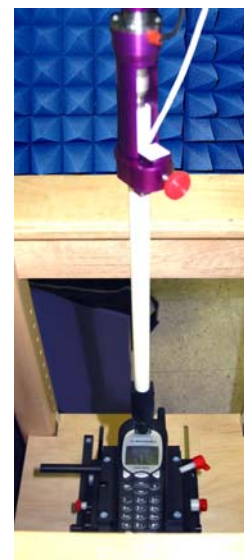

Probe Specifications:

Maximum coil length	6.55 mm
Maximum coil diameter	2.29 mm
DC Resistance	900 Ω
Wire size	51 AWG
Inductance	140 mH at 1 kHz
Sensitivity	-60.5 dB (V/Am) at 1 kHz
Sensitivity Tolerance	±0.5 dB

Connector Types:

- 3.5mm standard audio
- BNC
- 6 pin bayonet ALS-Daq Paq 3
- Custom design available on request

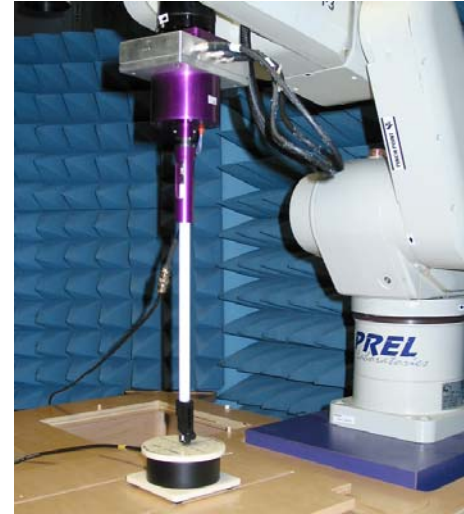

Mechanical Specifications:

- Twin axis T-Coil which rotates around central axis for horizontal and vertical polarization
- Mountable via end connector which can be custom fitted to user specification. Length (from central element of T-Coil) 350mm
- Shaft diameter 12mm

Meets specification of ANSI-PC63.19

Polarization:

The probe has the capability of being polarized on the horizontal and vertical planes.

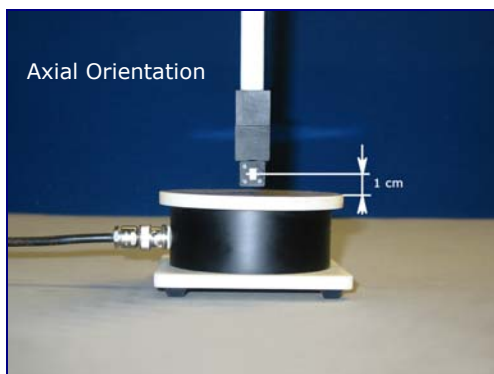

FCC ID: OVFKWC-K24B

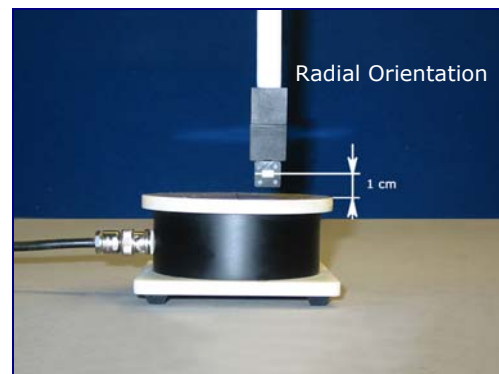

Project Number: KYOB-K323-5239

T-coil positioning at the Calibration Reference Point

AXIAL MEASUREMENTS

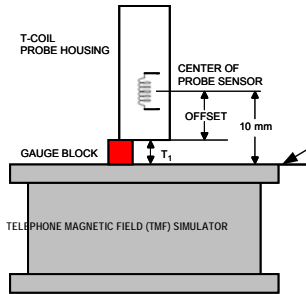

RADIAL MEASUREMENTS

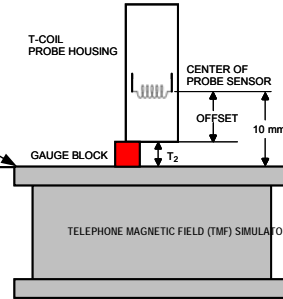

TOP SURFACE OF THE TMFS

T_1 equals to T_2 for APREL
ALS-T-020A
 T_1 may not be equal to T_2 for
other manufactures

T-coil positioning at the Calibration Reference Point on Magnetic Dipole™

Distribution of magnetic field (axial component) at 5x5cm reference plane
Input connector at -X

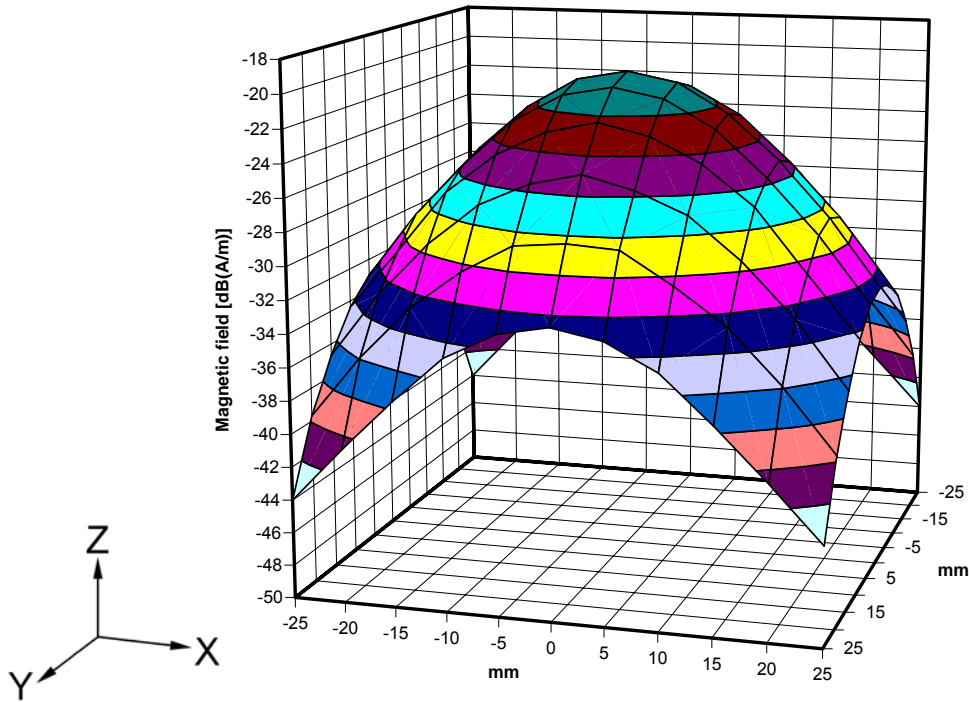

Axial component distribution from a known source using the APREL T-Coil Probe

Distribution of magnetic field (radial component) at 5x5cm reference plane
T-coil axis aligned with axis X, input connector at -X

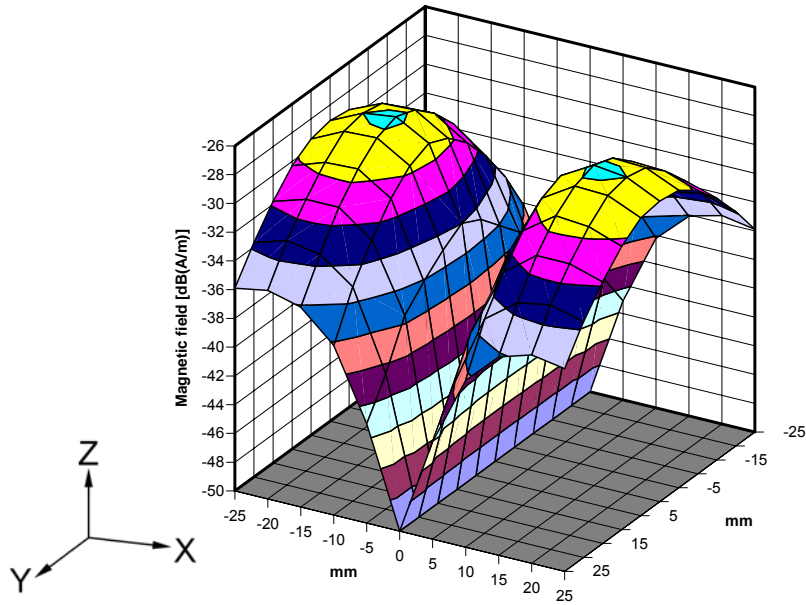

Radial component distribution (X axis) from a known source using the APREL T-Coil Probe

Distribution of magnetic field (radial component) at 5x5cm reference plane
T-coil axis aligned with axis Y, input connector at -X

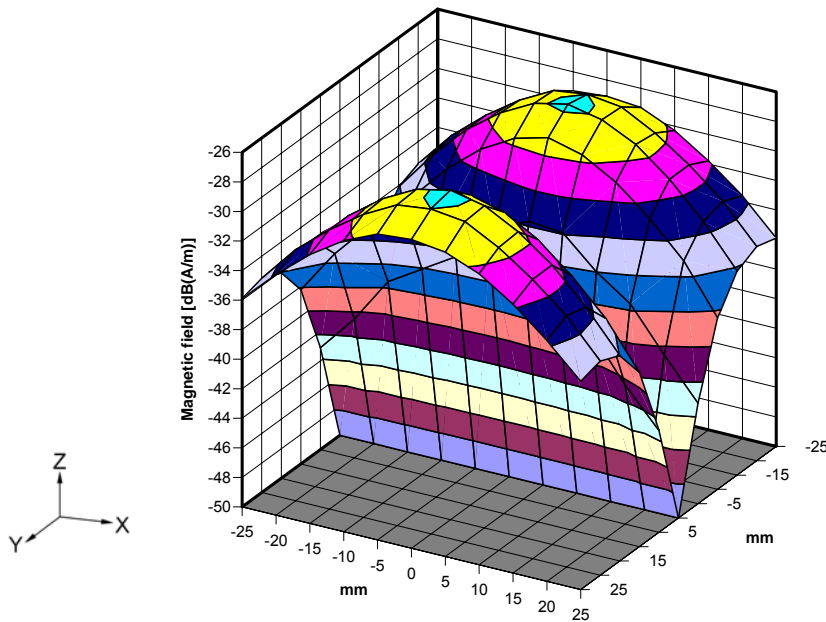

Radial component distribution (Y axis) from a known source using the APREL T-Coil Probe

APREL *Laboratories*

SAR & HAC Instruments for Wireless • Consulting • Research • Standards • Compliance • Training

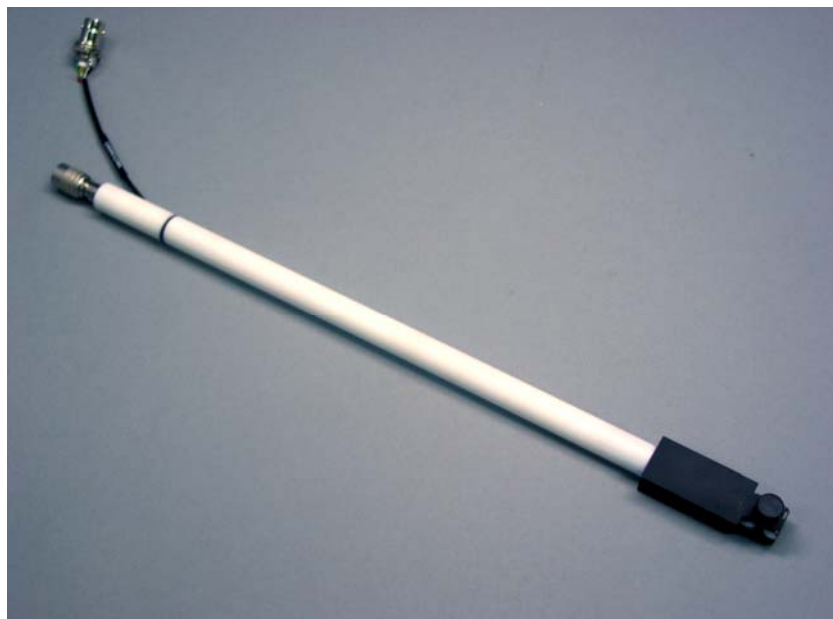
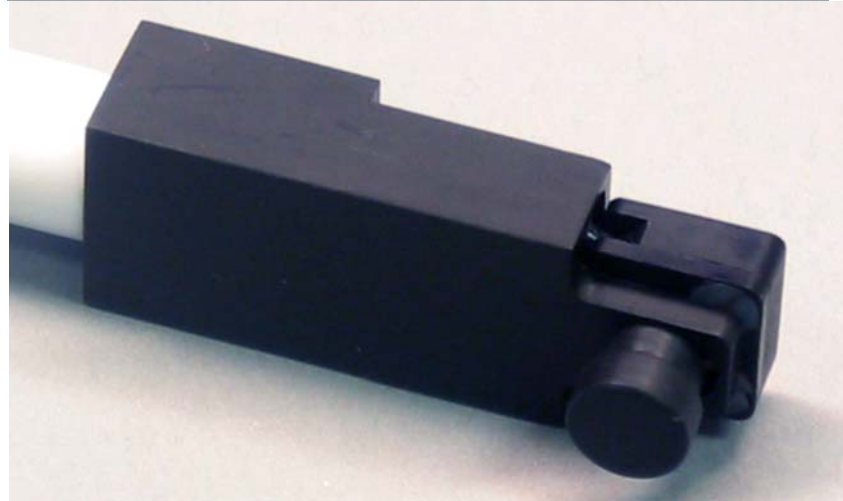

FCC ID: OVFKWC-K24B

Project Number: KYOB-K323-5239

Validation of the T-Coil and Measurement System was conducted using the APREL Laboratories Telephone Magnetic Field Simulator.

Description

Telephone Magnetic Field Simulator (TMFS) is a compact, highly reproducible and well characterized validation device designed to generate audio frequency magnetic fields. It is intended to be used with any, laboratory grade audio frequency Signal Generator and AC Voltmeter.

Applications

- *Validation of Hearing Aid Compatibility (HAC) testing systems (manual and automated)*
- *Research in the area of Hearing Aid Compatibility.*

* See Appendix A for application notes.

References - standards

- *ANSI 63.19-2001*
- *FCC title 47 CFR rule part 68*
- *TIA/EIA-IS-968*
- *CS-03*
- *ETSI 300-381*

Features

- *Accurately characterized relationship between input signal and resulting magnetic fields allows for its application without a need for complicated magnetic field measurements.*
- *The TMFS can be used with any type of audio frequency signal generator regardless its output impedance.*
- *Grid on the top reference plane provides easy reference for T-coil positioning.*
- *High reproducibility provides long-term stable reference source.*

TMFS Magnetic Dipole™ Specifications

Physical:

- *Dimensions:* *With-Depth 4 × 4 inch, Height 2.05inch*
- *Enclosure material:* *ABS*
- *Input connector* *BNC jack*

Electrical & magnetic:

- *Calibration Reference Point located 10mm above the geometrical center of the TMFS surface.*
- *Frequency range* *50Hz to 10kHz (consistent with ANSI 63.19-2001).*
- *Magnetic field generated at 1kHz with 0.5V (-6dBV) input:*
 - axial component:* *-20.0dB(A/m) at the Calibration Reference Point.*
 - radial component:* *-27.5 dB(A/m) all points on the circle with 16mm radius surrounding the Calibration Reference Point.*
 - horizontal Isotropic response:* *0.4dB (max.)*

- Magnetic field distribution at the plane of the Calibration Reference Point

TMFS typical magnetic field distribution on the reference plane

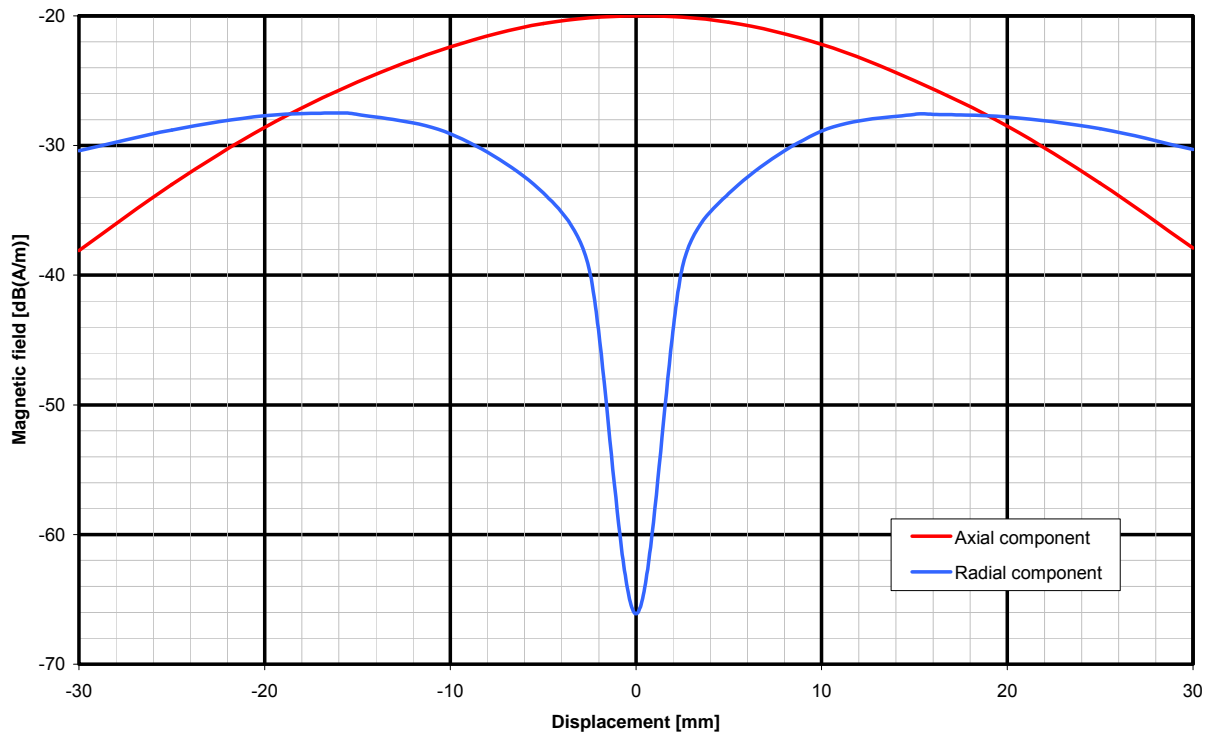

Typical field distribution in the Reference Plane

- Frequency response at the Calibration Reference Point:

Flatness In frequency range 300Hz to 3kHz: 1.0dB (max), 0.8dB (typ.)

Flatness In frequency range 100Hz to 10kHz: 1.2dB (max), 1.0dB (typ.)

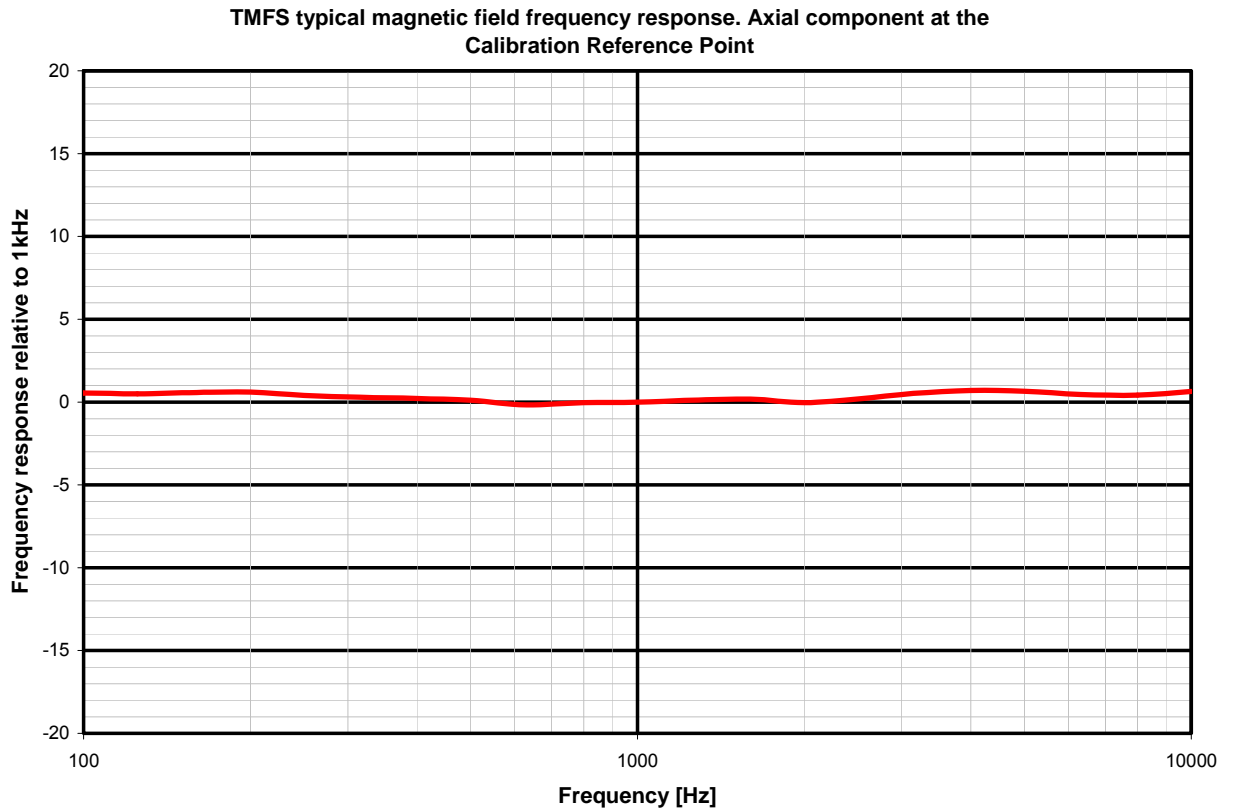

Typical frequency response

- Linearity as measured at the Calibration Reference Point:

TMFS linearity - Axial magnetic field at CRP vs input signal at 1kHz

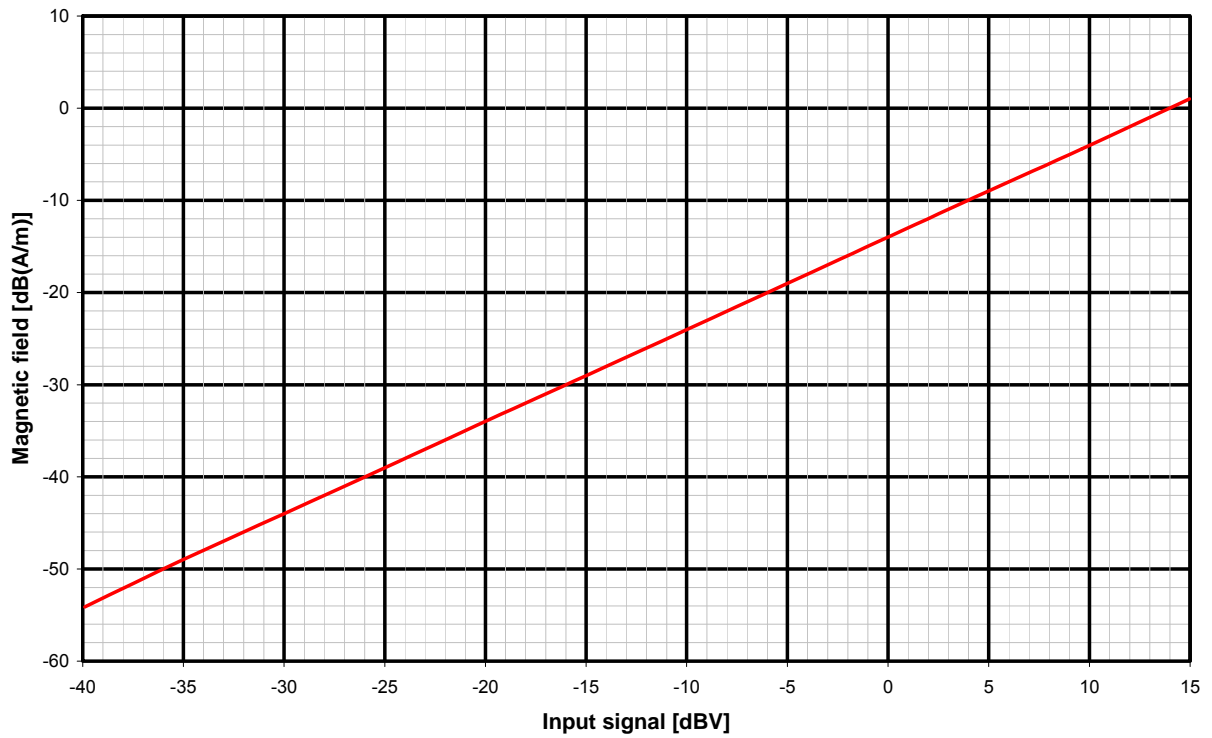

Typical linearity response

Other:

- *Operating temperature range: +10°C to +40°C*
- *Storage temperature range: -35°C to +70°C*
- *Shock & Vibrations (in own packing box): meets IEC 60068-2-6 test Fc. (sinusoidal vibration) & IEC 60068-2-27 test Ea (shock).*

TMFS Magnetic Dipole™ Application Note

T-coil positioning at the Calibration Reference Point

Appropriate spacer should be used to maintain 10mm distance from the center of the T-coil to the TMFS reference plane regardless variations in T-coil offset to the edge of its housing.

This insures that the T-coil center is located precisely at the TMFS Calibration Reference Point.

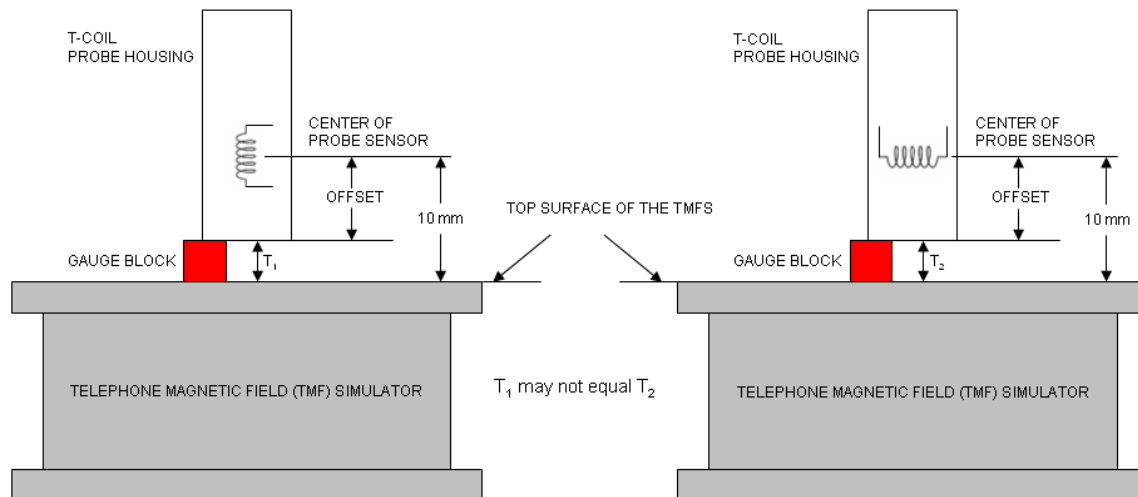

T-coil positioning at the Calibration Reference Point

Connecting TMFS to the Signal Source

Typical setup of TMFS is shown in Fig. A.2

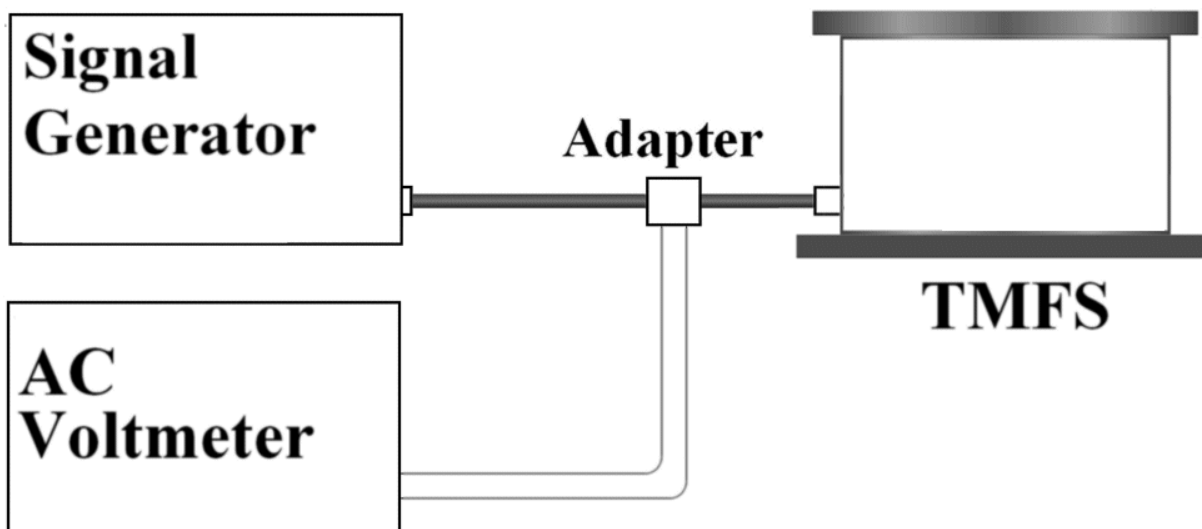

Typical setup

Use of TMFS for HAC system & T-coil verification

A range of parameters can be verified with the use of TMFS

Absolute Sensitivity of the T-Coil

This verification measurement has to be performed with the T-coil oriented for axial magnetic field component and requires the T-coil to be positioned precisely at the TMFS Calibration Reference (see Fig. A.1). Signal Generator is set to 1kHz and 0.5Vrms (-6dBV) output. Ensure the system indicates -20dB(A/m) after T-coil correction factor is applied.

Amplitude Linearity of the System

The magnetic field distribution at 1kHz of the TMFS at the Reference Plane is characterized at 0.5Vrms (-6dBV) delivered to the input BNC connector. However inherent linear relationship exists between the input signal level and absolute magnetic field levels generated, therefore other levels of magnetic field can be obtained by scaling the input signal level accordingly.

This can be used to verify the system linearity by stepping the input signal level by constant step size (0.5dB for example), recording and then plotting the system reading.

The conversion factor for the Calibration Reference Point is -14dB (A/m)/V at 1kHz, therefore in order to cover the magnetic field range of -50 to 0dB(A/m) the input signal level has to be stepped from -36 to +14dBV.

System Signal to Noise Ratio

With the T-coil axially oriented and positioned in the Calibration Reference Point (see Fig. A.1) set the Signal Generator to 1kHz and the level to -36dBV (20mVrms) and record the system reading. Turn the Signal Generator off (or disconnect it) and ensure the system indicates at least 10dB drop in reading.

T-coil Rejection of Opposite Component of the Magnetic Field

At the Calibration Reference Point the amount of radial component of the magnetic field generated by the TMFS is very low, typically min. 50dB below the amount of axial component.

This can be used to estimate the T-coil cross-component rejection simply by placing it at the Calibration Reference Point and orienting it for radial component pickup (horizontally).

Higher than 0.5V input level should be used, if the system signal to noise ratio turns out to be insufficient for 40dB (an more) rejection measurements.

General ALSAS-10U HAC System Description

The ALSAS-10U has an optional HAC module which is utilised to conduct the HAC T-Coil Evaluation. The methods employed follow closely the latest requirements of the C63.19 standard. Additional hardware is utilised for the assessment of the T-Coil mode and this comprises of a T-Coil probe which is connected to an amplifier which feeds a unique data acquisition card that is located within the host PC.

HAC Module

Description	Perform HAC testing for Wireless communications devices (WD) using ALSAS system and HAC software. Additional Hardware may be required.
Test Frequency	As per ANSI IEEE C63.19 2006 800 – 950 MHz
Test Format	1.6 – 2.0 GHz
Compliance Test	<ul style="list-style-type: none"> ▪ GSM, TDMA, CDMA, iDEN, etc.
Measurements	<ul style="list-style-type: none"> ▪ FCC Regulation (ANSI C63.19) ▪ RF Emissions Test - Measurements of the near-field electric field and magnetic fields emitted by a WD. ▪ RF E-Field emissions. ▪ RF H-field emissions. ▪ Audio Band Magnetic Signal Test - Magnetic field measurements of a WD emitted via the audio transducer associated with the T-coil mode of the hearing aid. ▪ System Controlled Measurements ▪ T-Coil mode, magnetic signal strength in the audio band. ▪ T-Coil mode, magnetic signal and noise articulation index.
Report Generation	<ul style="list-style-type: none"> ▪ T-Coil mode, magnetic signal frequency response through the audio band.
Data Acquisition Hardware	Custom Designed Signal Amplifier Custom Configured Acquisition card. Frequency Range of 10-20kHz Resolution bandwidth 3 to 300 Hz in 1-3-10 steps Input amplitude range 1mV rms to 30 V rms Input impedance: 1 Mohm shunted by up to 30 pF Dynamic range > 80 dB Spurious Response at least 80 dB below input reference level Amplitude accuracy +/- .5 dB
Spectral Analysis Software	Custom Configured Software based on the Spectra+ software Platform.

Pre-Measurement Procedure

Reference Check

A reference check of the setup and instrumentation was performed using the APREL Laboratories TMFS. This involves positioning the TMFS at the position normally occupied by the DUT. Measure the emission from the TMFS and confirm that they are within the tolerance of the expected values.

Measurement of the Ambient and Test System Noise

The ambient and test system noise is measured before every assessment and shall be determined by placing the probe and DUT receiver in the position to be used for field strength measurements. We then remove the WD and measure the remaining noise field strength following the same method and over the same frequency range used for the DUT measurements. The noise should be at least 10 dB below the limit (specified in Section 7.3 ANSI-PC63.19-2006/5).

Subject Placement

The probe coil position and orientation follows the description in Section 6.3.4.4 (in ANSI –PC63.19-2006/5).

Audio Test signals

It is generally simpler and therefore preferred to use pure tone or sine wave test signals for audio band tests. However, accurate results may not be possible with some voice coders using simple sine wave signals. Such devices may require the use of voice-like signals such as real voice or artificial voice, as described in ITU recommendation P.50 (P.50 voice). Such signals may have frequency weighting and temporal characteristics that require additional processing to correlate with sine wave based test methods. It is up to the test operator to ensure that non-sinusoidal test signals are properly implemented. The ALSAS-10U and spectral signal application software will automatically set the scale to the applicable levels in line with the audio source used.

CDMA Audio Signal

For the purpose of CDMA testing the P.50 signal is fed through the base station emulator (CMU200) and normalized via a simple calibration routine to ensure that the signal is within the required tolerances and not in saturation. The signal after calibration is generally around -18dBm +/- 0.1dBm.

ABM Testing

Desired Plus Undesired T-Coil Signal Measurement

A measurement of the T-Coil signal at each of the magnetic measurement position has been made. These measurements are made over the frequency range of 300 to 3000 kHz in 1/3 octave bands centered at the ISO 266 R10 series of the standard test frequency.

Undesired Audio Band Magnetic Signal Measurement

A measurement of the T-Coil signal at each measurement position has been made. These measurements were made using an A-weighting filter, applied to the half-band integrated probe coil signal, as described in Section D. 18.2. These measurements were made in exactly the same probe positions as the desired signal measurement.

Undesired signal measurements were made with the batteries in place and without shielding of the DUT.

ABM2 Frequency Response

Measurement of ABM2

Assessments were made of the ABM2 frequency response and the following graphs relate to the results from this analysis which was made prior to the tests being executed on the DUT.

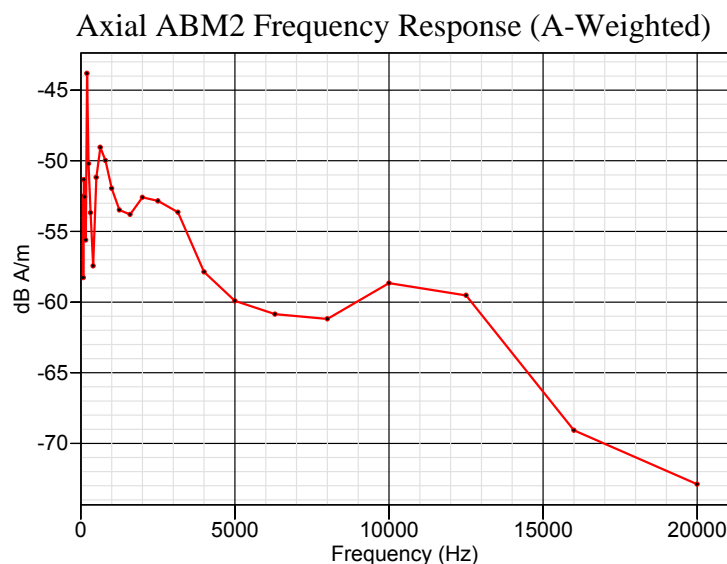

Axial ABM2 Frequency Response

FCC ID: OVFKWC-K24B

Project Number: KYOB-K323-5239

28

Radial X ABM2 Frequency Response (A-Weighted)

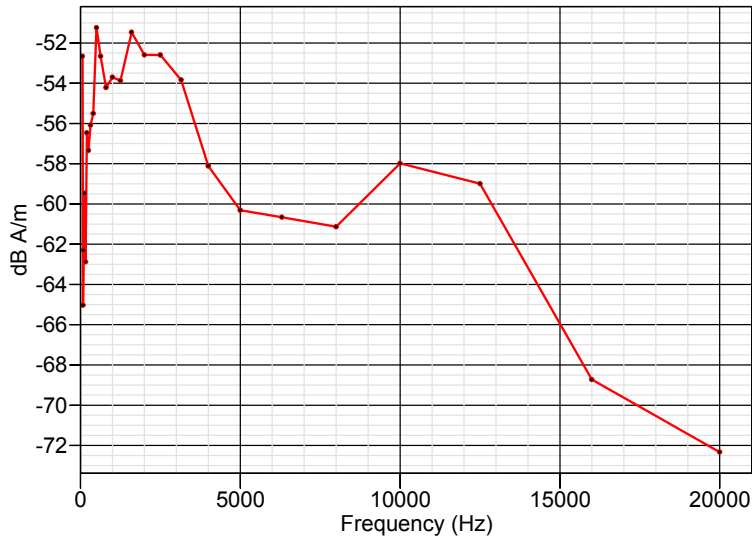

Radial X ABM2 Frequency Response

Radial Y ABM2 Frequency Response (A-Weighted)

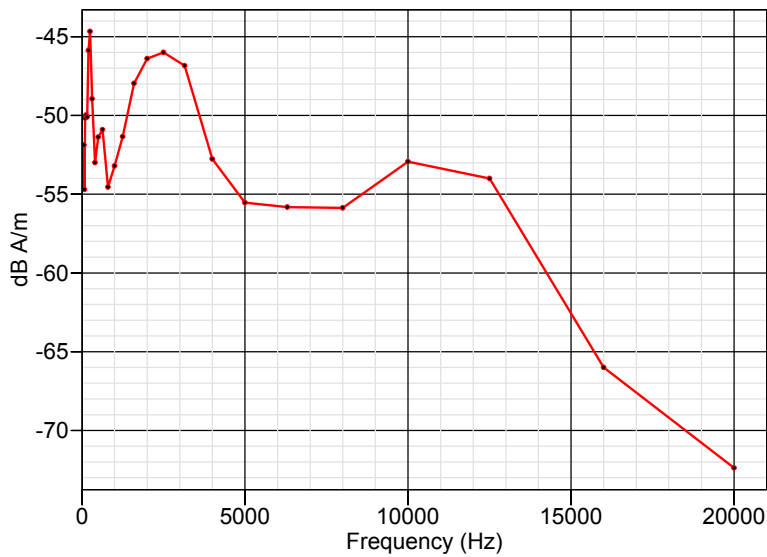

Radial Y ABM2 Frequency Response

Magnetic Field Frequency Response Measurement

The axial magnetic field strength was measured over the audio frequency band and particular focus was made for the frequency range from 300 to 3000 Hz.

Test Procedure as defined in ANSI-C63.19-2006/5

1. The DUT T-Coil signal test was performed in accordance with the measurement procedure described in the ANSI-C63.19-2006/5 Standard.
2. Measurements were performed at all three locations, with the correct probe orientation for a particular location, in a multi-stage sequence.
3. Measurements were made for the field intensity of the desired T-Coil signal (ABM1) that is useful to a hearing aid T-Coil.
4. The undesired magnetic components (ABM2) were then examined for each probe orientation to determine possible effects from the WD display and battery current paths that may disrupt the desired T-Coil signal.
5. A post assessment calculation of the ratio of the desired to undesired ABM signals was made. Results from this activity were compared to the value with the limits (in Table 7-7 ANSI-PC63.19-2006/5) so as to determine and record the signal category.

Category	Telephone parameters WD signal quality ((signal + noise) –to-noise ratio in (dB)
T1	0 – 10 dB
T2	10 – 20 dB
T3	20 - 30 dB
T4	> 30 dB

6. For the axial field location only the ABM1 frequency response was determined in the third stage. The axial magnetic field was measured over the audio frequency band and recorded for the frequency range 300 to 3000 Hz.

Test Procedure

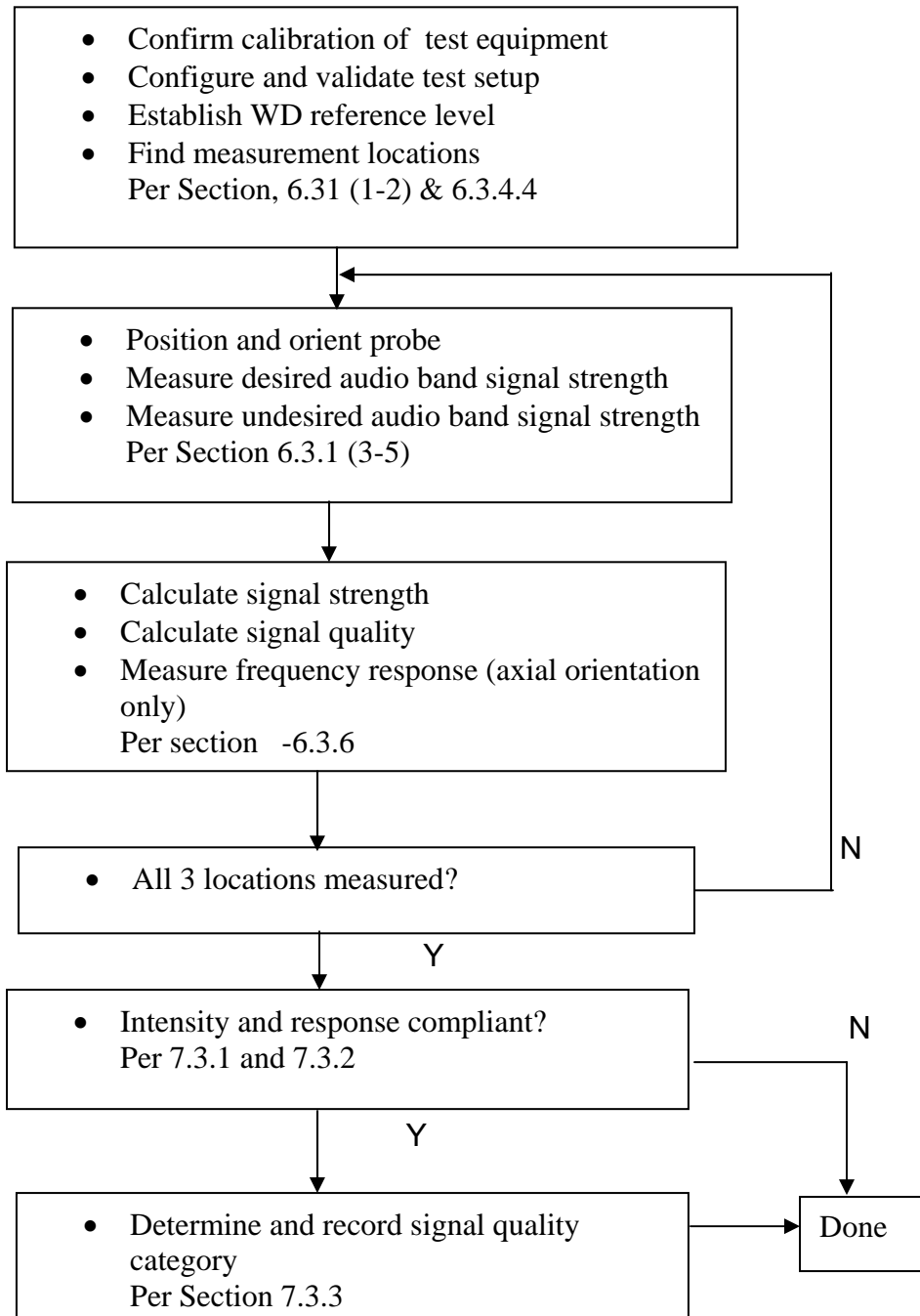

ANSI-C63.19-2006/5 test procedure sequence

Test Equipment

Name	Model/Serial Number	Calibration On
IBM computer	Type: 8307, Model: 41U, SN: 305	NA
APREL Laboratories Measuring Amplifier	20-20000 Hz SN: 1333723	May 2006
Customized Spectral Analysis System	Version 5.0.01	May 2006
APREL Laboratories Customized Data Acquisition Card	22Hz-22kHz	May 2006
Telephone Magnetic Field Simulator (TMFS)	300-01152	June 2006
Twin Axis T-Coil Probe	T-020-101	June 2006
R&S CMU200	100-2346	April 2006
ALSAS-10U	NA	Prior to Test
Anritsu MT8801c Communications Test Set	301598	August 2005

Set Up

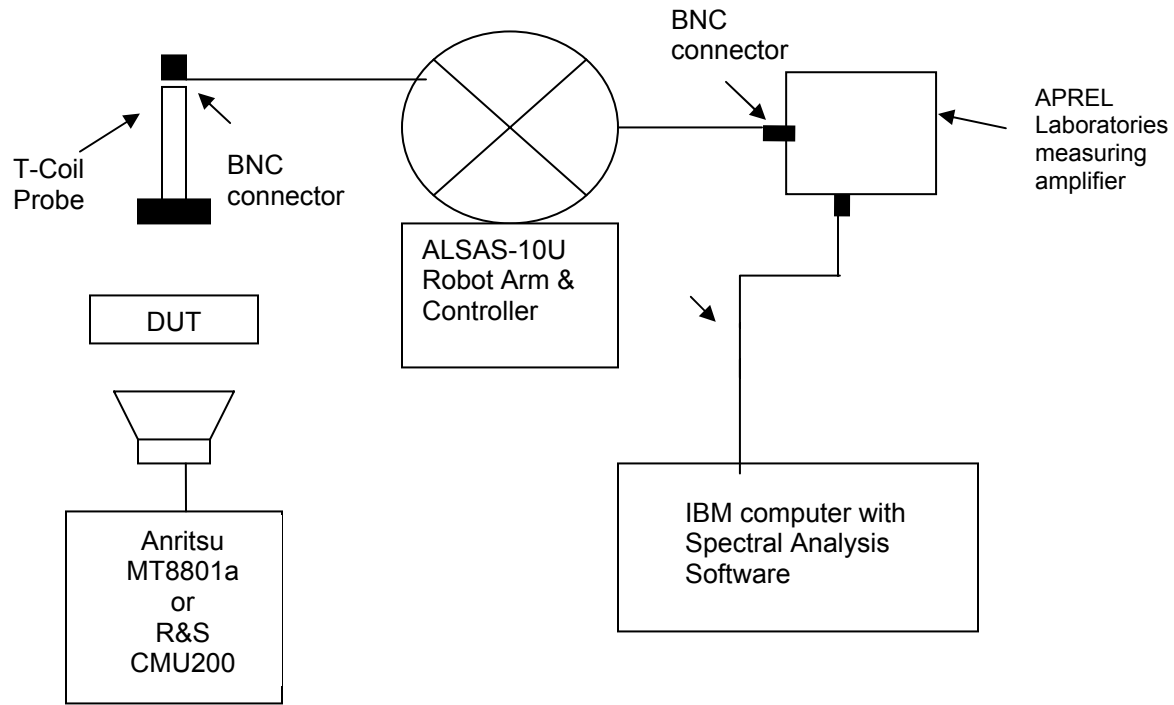

Typical Probe Position and Orientation

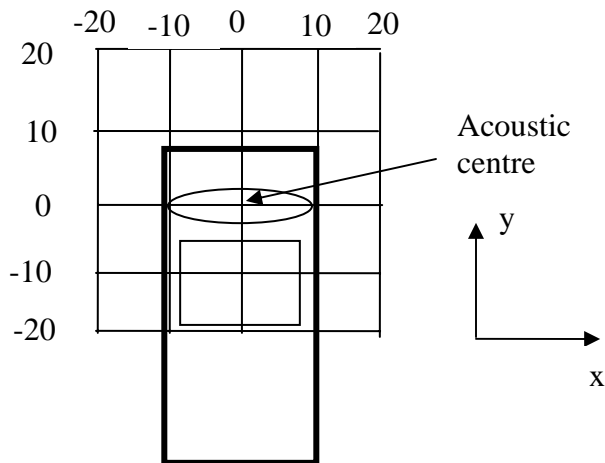

Scan area

The scan area is 20×20 (mm)², as shown above with a scanning increment of 5 mm.

Kyocera Device Under Test Physical Size

The Kyocera K323 was tested as received and measurement scans were defined as per the mechanical measurements made by APREL Laboratories on the DUT.



Test Results

System Validation

Axial field

TMFS Axial field Data

TMFS position		Rot. Position			Reading [dB(A/m)]
x	y	X	y	z	
-25.00	0.00	430.00	-2.07	86.42	-31.61
-20.00	0.00	435.00	-2.07	86.43	-28
-15.00	0.00	440.02	-2.07	86.43	-24.71
-10.00	0.00	445.03	-2.06	86.43	-22.1
-5.00	0.00	450.05	-2.06	86.43	-20.56
0.00	0.00	455.05	-2.05	86.44	-19.99
5.00	0.00	460.07	-2.05	86.44	-20.77
10.00	0.00	465.08	-2.04	86.45	-22.65
15.00	0.00	470.08	-2.03	86.46	-25.46
20.00	0.00	475.09	-2.03	86.46	-29.03
25.00	0.00	480.11	-2.02	86.47	-33.26

TMFS Axial

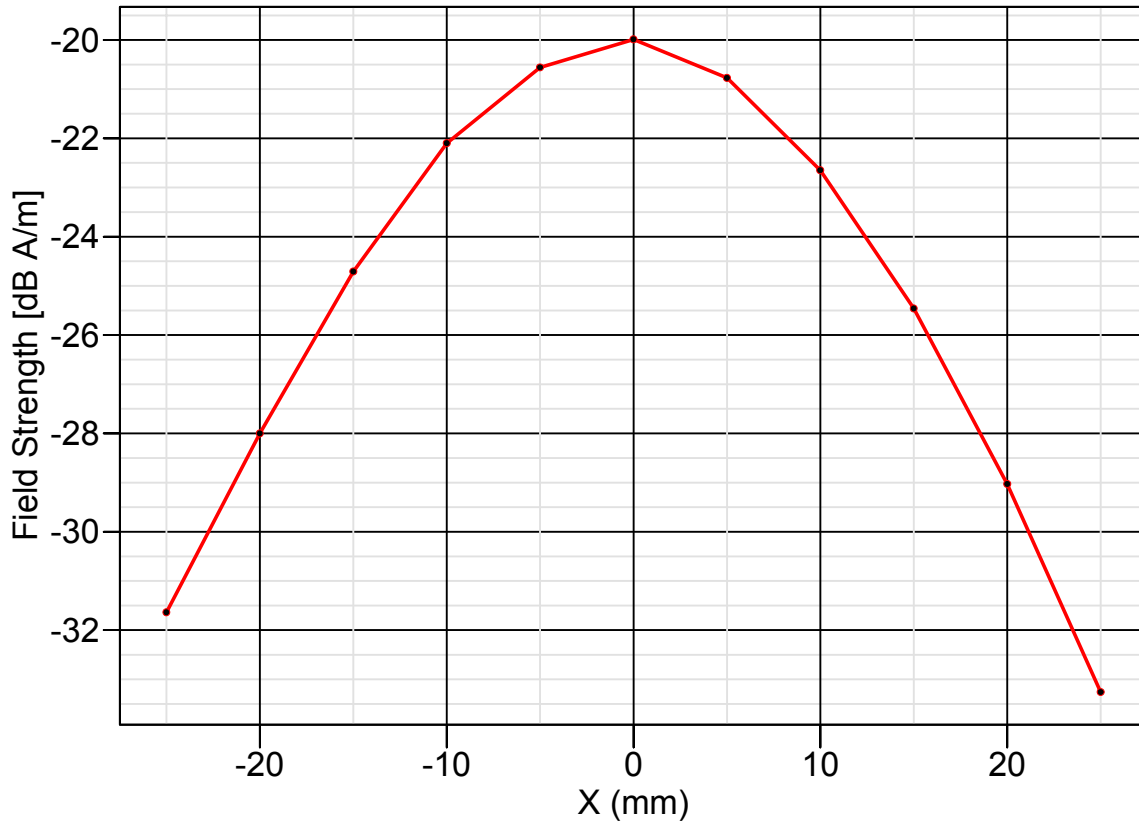

TMFS Axial Field Data

Radial x field

Table 5 TMFS Radial X Field data

TMFS position		Rot. Position			Reading [dB(A/m)]
x	y	x	y	z	
-25.00	0.00	455.10	-26.44	86.47	-28.9
-20.00	0.00	455.11	-21.45	86.48	-27.95
-15.00	0.00	455.12	-16.46	86.48	-27.87
-10.00	0.00	455.12	-11.47	86.48	-29.57
-5.00	0.00	455.14	-6.45	86.48	-34.59
0.00	0.00	455.14	-1.44	86.48	-61.76
5.00	0.00	455.15	3.57	86.48	-33.04
10.00	0.00	455.16	8.57	86.49	-28.64
15.00	0.00	455.17	13.58	86.49	-27.51
20.00	0.00	455.18	18.57	86.50	-27.77
25.00	0.00	455.21	23.56	86.51	-28.88

TMFS Radial X

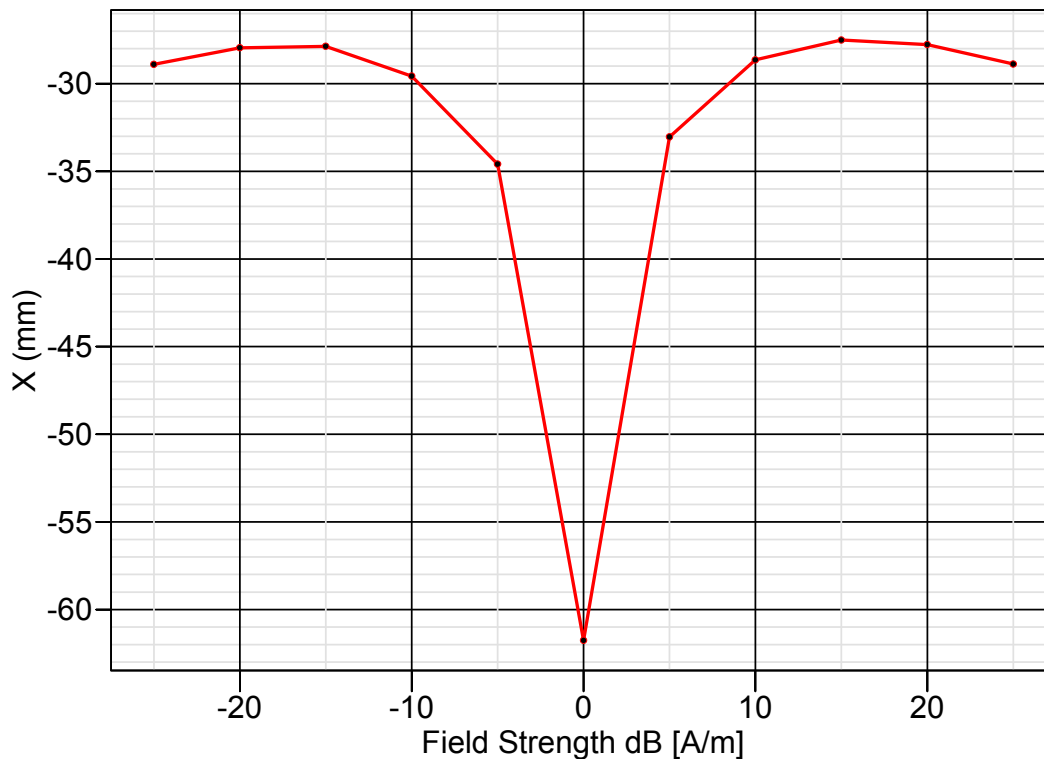

TMFS Radial X Field Data

Radial y field

TMFS Radial (y) Field Data

TMFS position		Rot. Position			Reading
x	y	x	y	z	[dB(A/m)]
0.00	-25.00	429.98	-1.57	86.42	-29.29
0.00	-20.00	434.98	-1.56	86.43	-28.18
0.00	-15.00	440.00	-1.55	86.43	-27.94
0.00	-10.00	445.01	-1.54	86.43	-29.2
0.00	-5.00	450.03	-1.53	86.43	-34.17
0.00	0.00	455.03	-1.52	86.44	-59.45
0.00	5.00	460.05	-1.51	86.44	-34.16
0.00	10.00	465.06	-1.50	86.45	-29.35
0.00	15.00	470.06	-1.49	86.46	-27.95
0.00	20.00	475.07	-1.47	86.46	-28.07
0.00	25.00	480.09	-1.47	86.47	-29.12

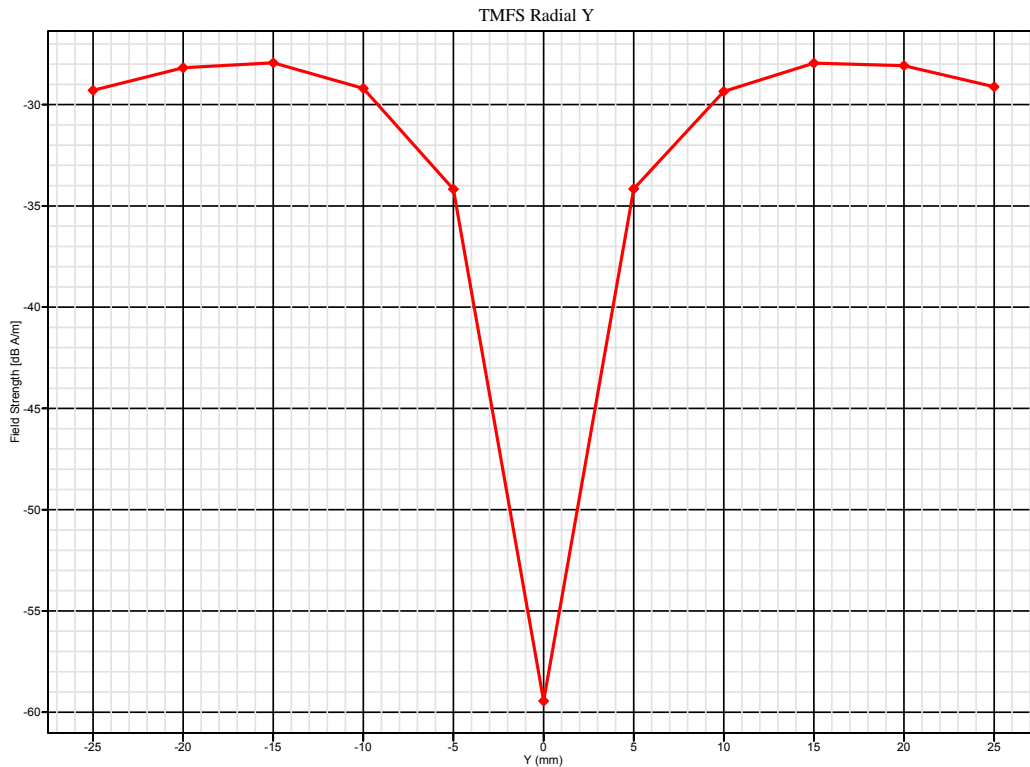

TMFS Radial Y Plot

Frequency response

Input signal level is 0.5 V, at 1 kHz.

TMFS frequency response data

Freq(Hz)	Raw reading [dB(uV)]	Correc. Factor	Correced value [dB(A/m)]	Relative to ikHz (dB)
315.00	79.19	-63.73	-19.22	-0.08
400.00	81.17	-61.66	-19.32	-0.18
500.00	83.15	-59.72	-19.28	-0.14
630.00	85.14	-57.71	-19.30	-0.16
800.00	87.19	-55.64	-19.32	-0.17
1000.00	89.31	-53.70	-19.14	0.00
1250.00	91.49	-51.76	-18.90	0.25
1600.00	93.57	-49.62	-18.96	0.18
2000.00	95.11	-47.68	-19.36	-0.22
2500.00	98.16	-45.74	-18.25	0.90
3150.00	100.61	-43.73	-17.80	1.34

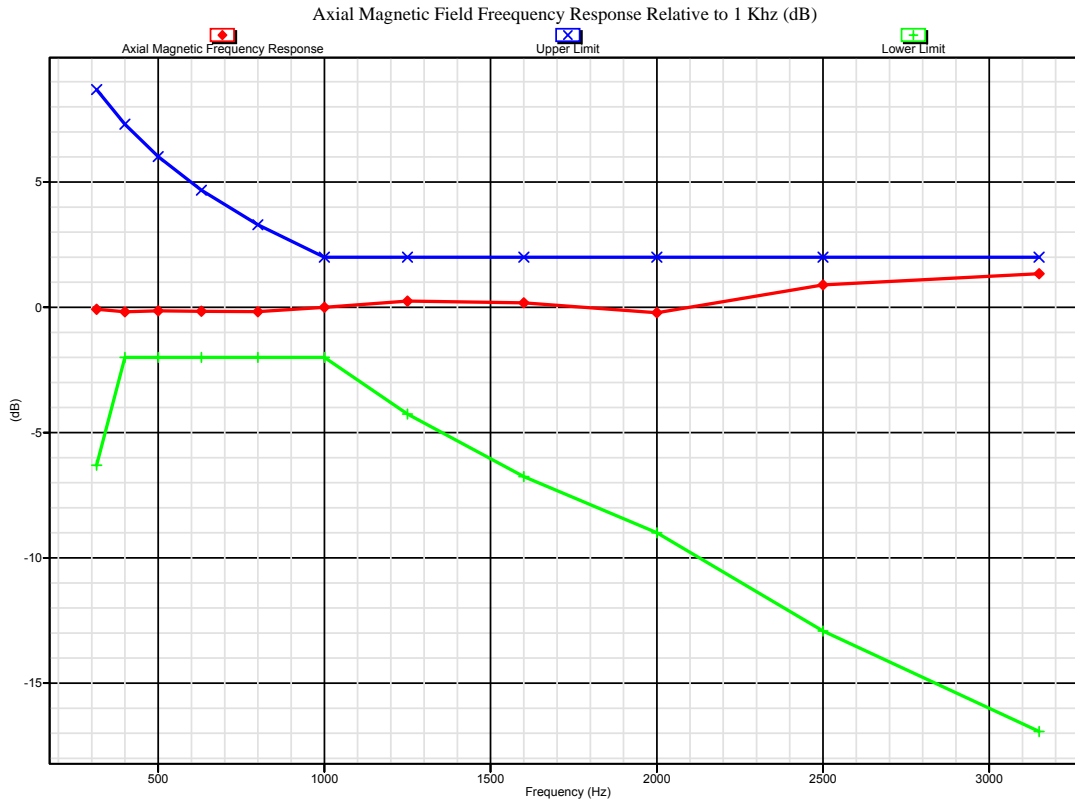

TMFS Frequency Response Plot

Test Results

Kyocera DUT

Results for T-Coil Analysis Axial & Radial

The following results are based on the analysis on the Kyocera DUT which was assessed at APREL Laboratories. Low, mid and high channels were assed and it was found that no change could be observed from the results.

For the CDMA 800 Band the worst case data as presented was found at channel

For the CDMA 1900 Band the worst case data as presented was found at channel

Probe Orientation	Axial		Radial X		Radial Y	
	CDMA 800	CDMA 1900	CDMA 800	CDMA 1900	CDMA 800	CDMA 1900
Band	CDMA 800	CDMA 1900	CDMA 800	CDMA 1900	CDMA 800	CDMA 1900
X,Y Coordinates	(10,0)	(10,0)	(0,0)	(0,0)	(10,-10)	(10,-10)
ABM1 [dB (A/m)]	-10.41	-6.65	-14.28	--16.15	-17.00	-17.99
ABM2 [dB (A/m)]	-53.20	-52.52	-51.95	-51.66	-53.70	-53.53
T-Coil coupling Field intensity limit [dB (A/m)]	-13	-13	-18	-18	-18	-18
Margins [dB(A/m)]	2.59	6.35	3.72	1.85	1.00	0.01
Verdict	Pass	Pass	Pass	Pass	Pass	Pass
Signal Quality (dB)	42.79	45.87	37.67	35.51	36.70	35.54
Category	T4	T4	T4	T4	T4	T4

Axial Field Analysis



Device Axial Area Scan

WD Axial Field Distribution (800 MHz)

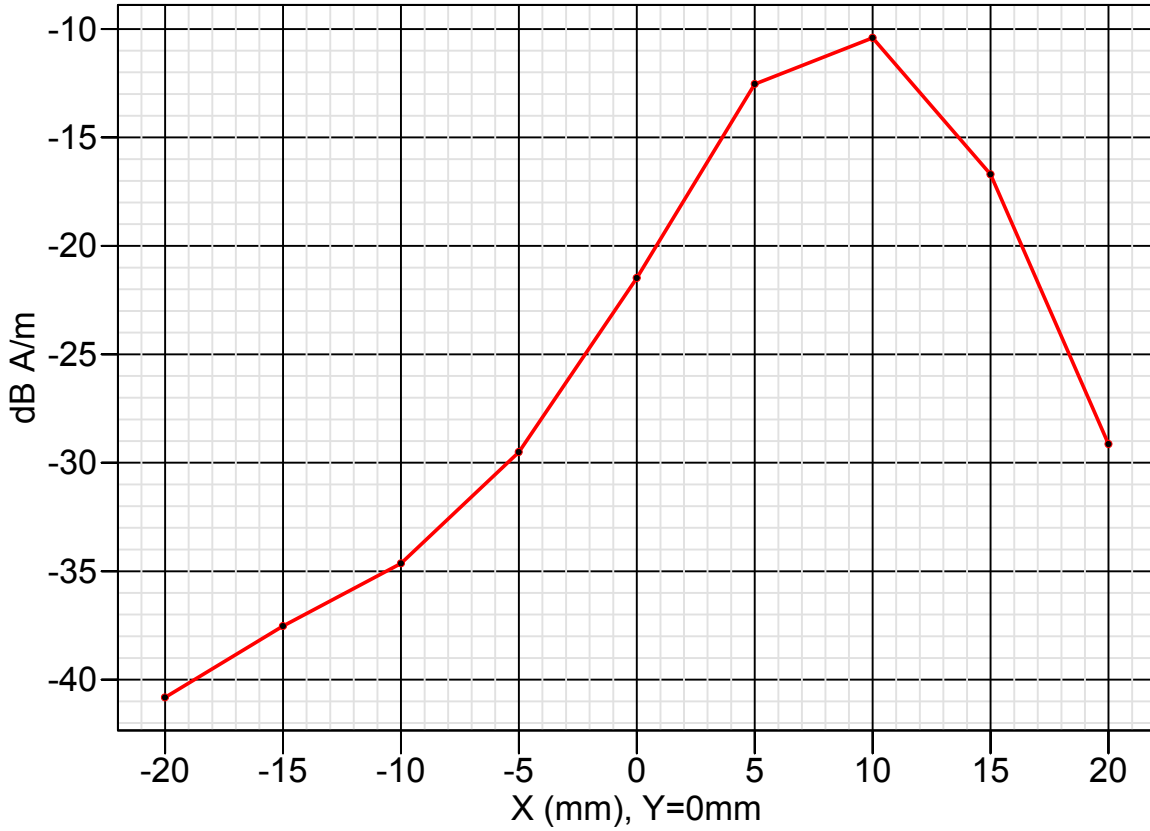

Axial Field Distribution

WD Axial Field Distribution (1900 MHz)

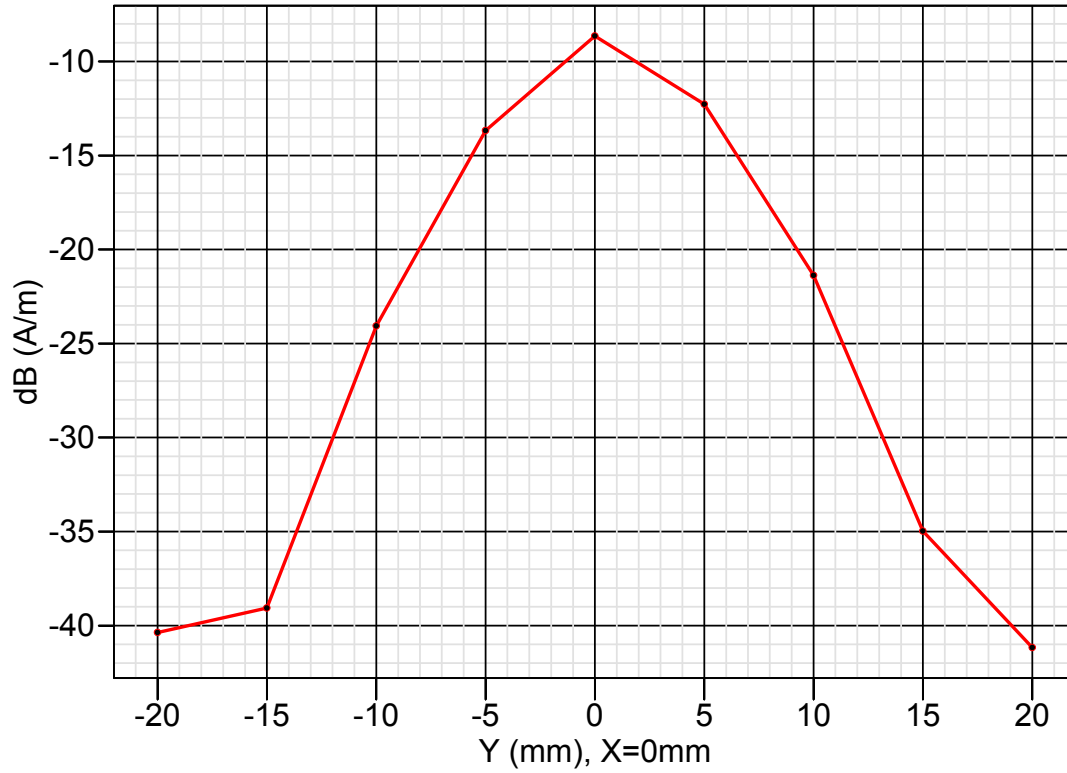

Axial Field Distribution



Axial Area Scan Cellular Band



Axial Area Scan PCS Band

Radial X Field Analysis



Radial X Probe Position

Strongest radial x field location: (0,0)

WD Radial X Field Distribution (800 MHz)

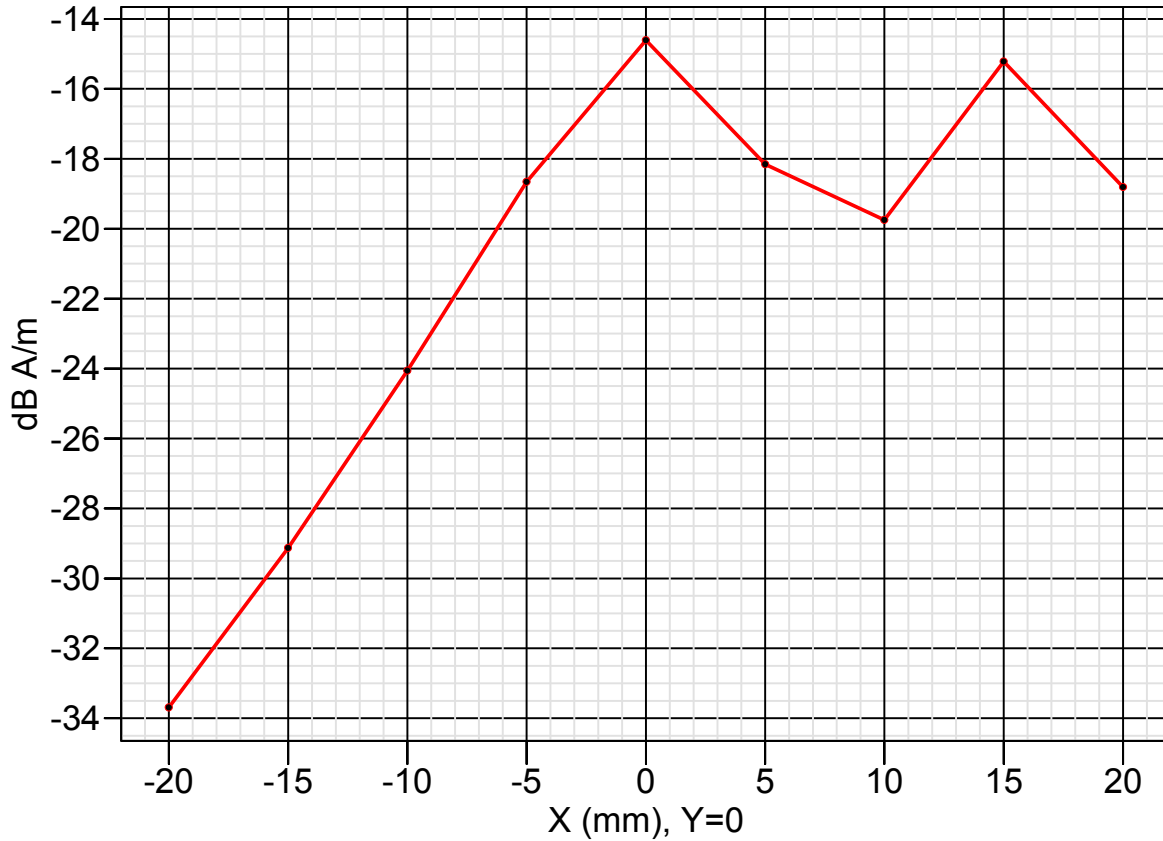

Radial X Distribution

WD Radial X Field Distribution (1900 MHz)

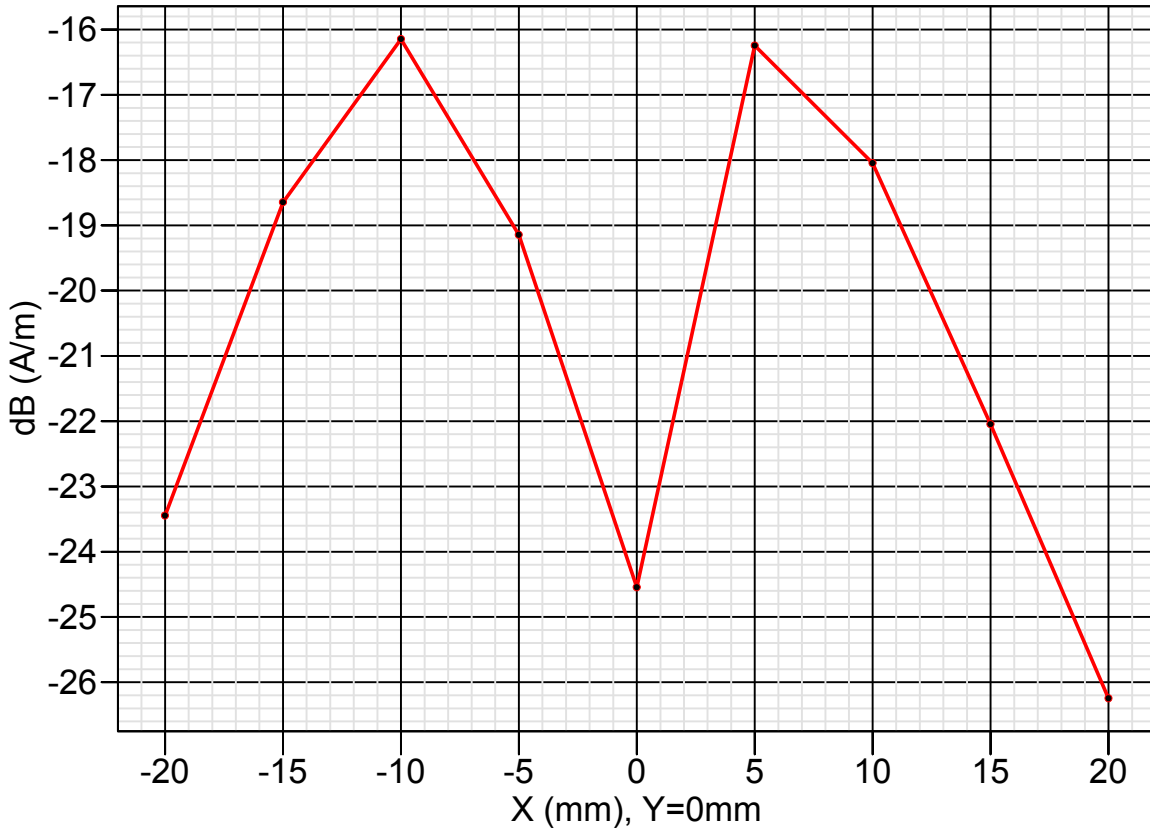

Radial X Distribution



Radial X Area Scan Cellular Band



Radial X Area Scan PCS Band

Radial Y Field Analysis



Radial Y Probe Position

Strongest radial y field location: (10, -10)

WD Radial Y Field Distribution (800 MHz)

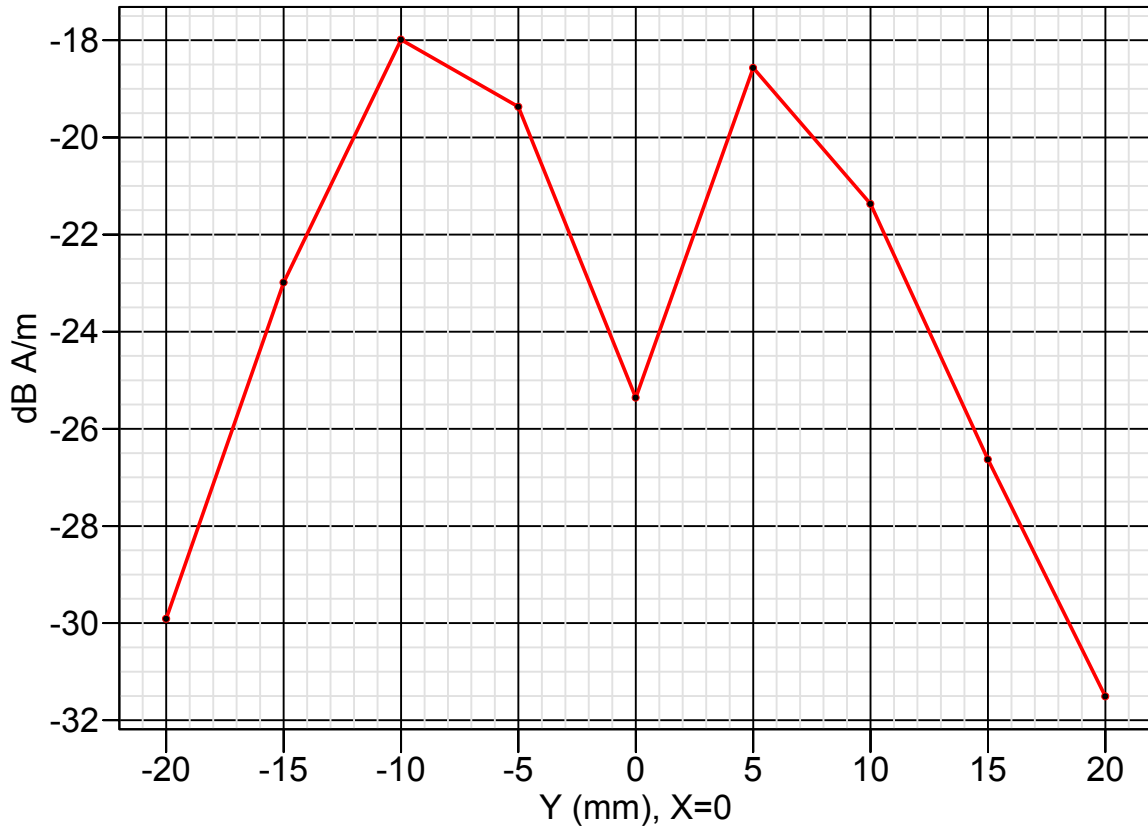

Radial Y Distribution

WD Radial Y Field Distribution (1900 MHz)

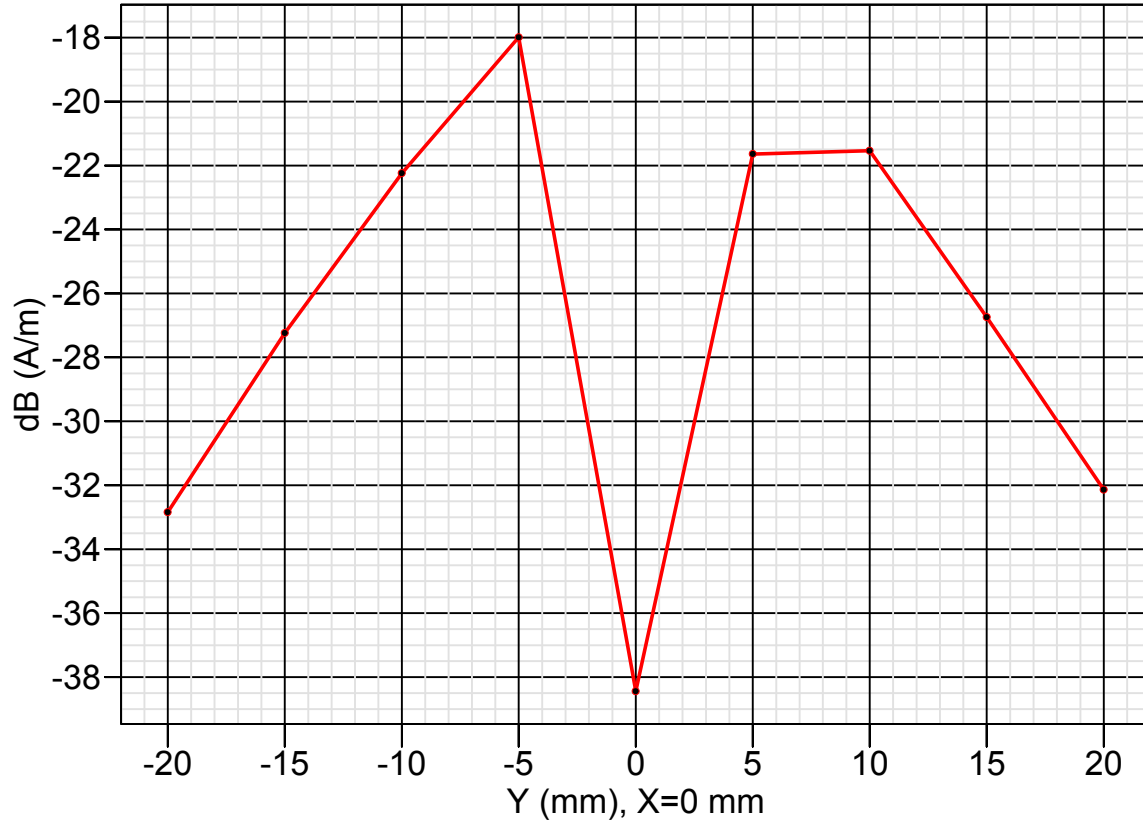

Radial Y Distribution



Radial Y Area Scan Cellular Band



Radial Y Area Scan PCS Band

Results for T-Coil Frequency Response Analysis

Axial Magnetic Field Frequency Response (Rel. 1 KHz)

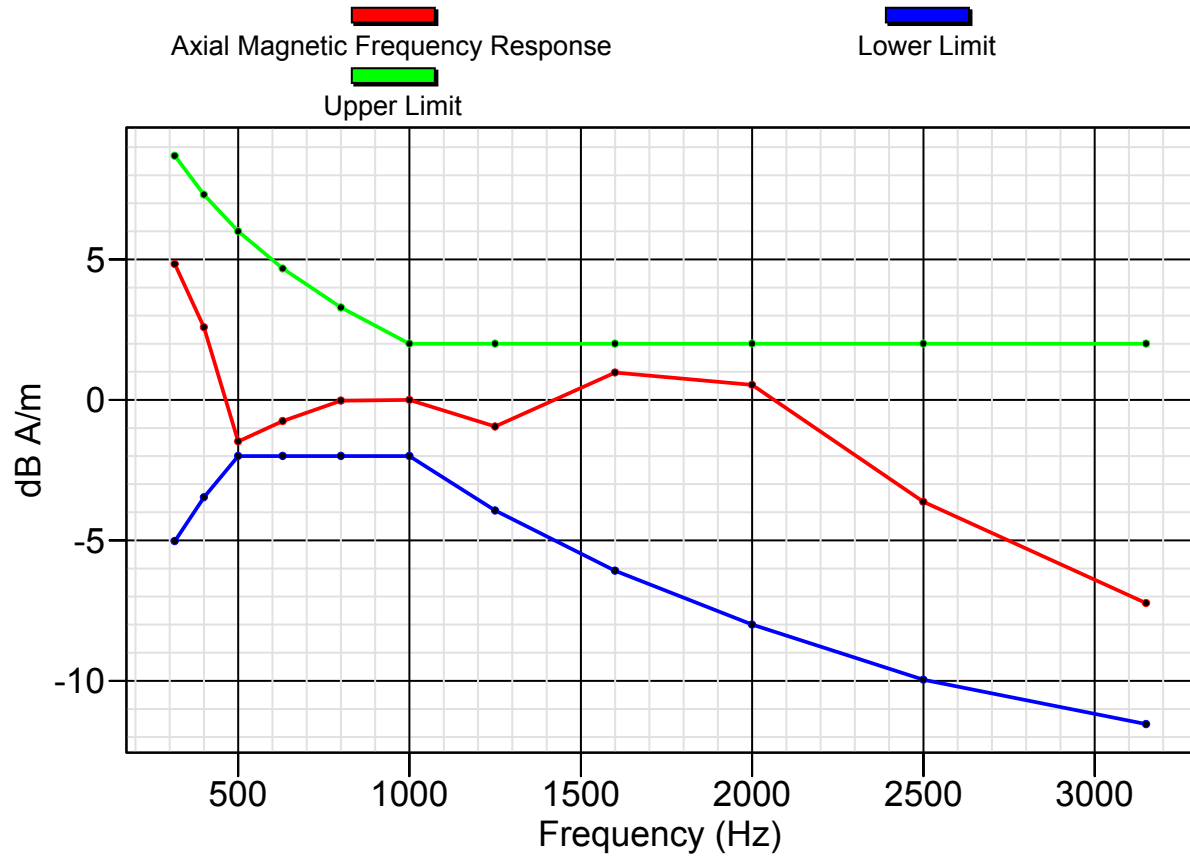

Frequency Response CDMA 800

Axial Magnetic Field Frequency Response 1900 MHz (Rel. 1 KHz)

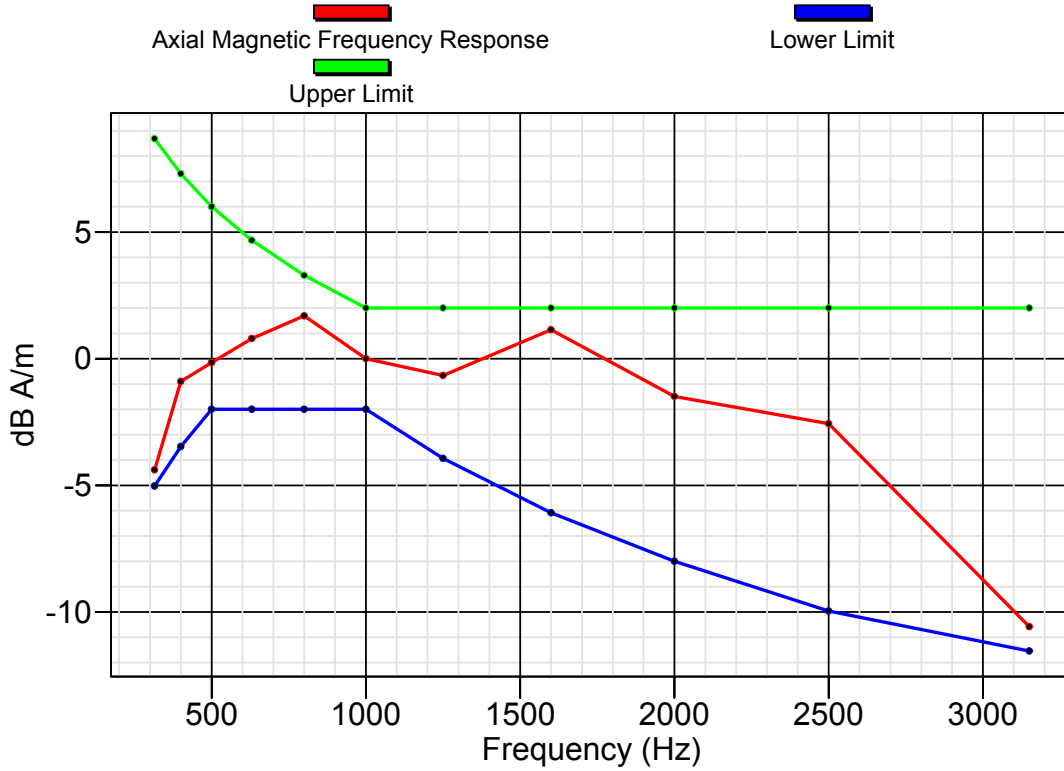

Frequency Response CDMA 1900

Measurement Uncertainty

Contribution	Data (dB)	Data (%)	Data Type	Probability Distribution	Divisor	Std. Uncertainty (%)
Probe Sensitivity		2.1	Tolerance	rectangular	$\sqrt{3}$	1.2
Probe Calibration		2.5	Standard Deviation	normal	1	2.5
Origin Qty		2.6	Tolerance	rectangular	$\sqrt{3}$	1.5
Origin Source		2.1	Tolerance	rectangular	$\sqrt{3}$	4.4
Frequency		3	Tolerance	rectangular	$\sqrt{3}$	1.7
Ambient		0.4	Tolerance	rectangular	$\sqrt{3}$	0.2
Readout Electronics		1	Standard Deviation	normal	1	1.0
Response Time		0.8	Tolerance	rectangular	$\sqrt{3}$	0.5
Integration Time		1.7	Tolerance	rectangular	$\sqrt{3}$	1.0
Probe Positioning Accuracy		0.4	Accuracy	rectangular		0.2
Device Holder Uncertainty		2	Standard Deviation	normal	1	2.0
System Repeatability		3	Tolerance	rectangular	$\sqrt{3}$	1.7
EUT Repeatability		5	Standard Deviation	normal	1	5.0
Combined Standard Uncertainty				normal	1	0.31 dB
Combined Uncertainty (coverage factor = 2)				normal	K=2	0.59 dB

Additional Set-Up Pictures

APREL *Laboratories*

SAR & HAC Instruments for Wireless • Consulting • Research • Standards • Compliance • Training





APREL *Laboratories*

SAR & HAC Instruments for Wireless • Consulting • Research • Standards • Compliance • Training



APREL *Laboratories*

SAR & HAC Instruments for Wireless • Consulting • Research • Standards • Compliance • Training



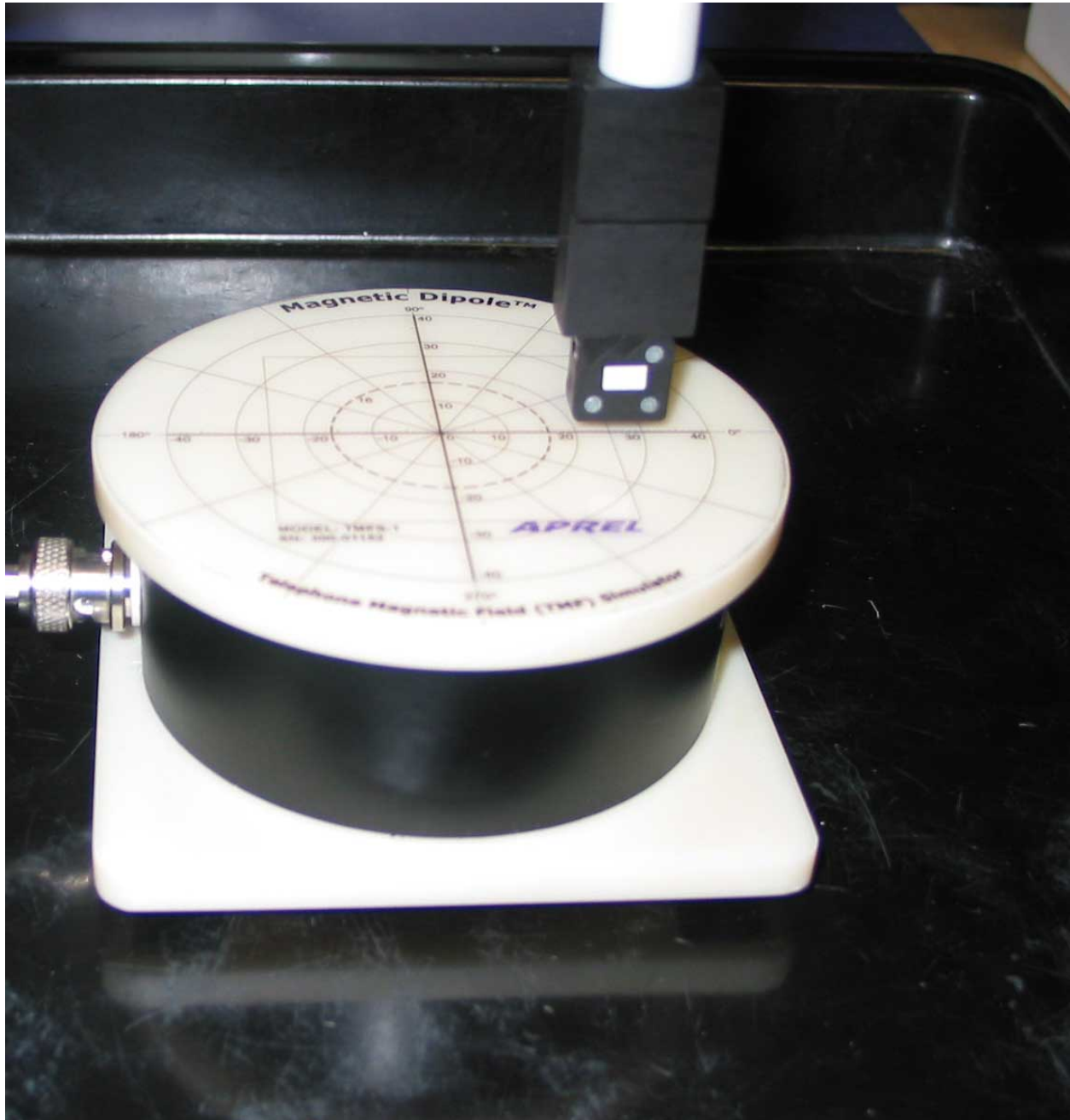



APREL *Laboratories*

SAR & HAC Instruments for Wireless • Consulting • Research • Standards • Compliance • Training





SAR & HAC Instruments for Wireless • Consulting • Research • Standards • Compliance • Training

Calibration Certificates

NCL CALIBRATION LABORATORIES

Calibration File No.: MD-708

Client: APREL Laboratories

CERTIFICATE OF CALIBRATION

It is certified that the equipment identified below has been calibrated in the **NCL CALIBRATION LABORATORIES** by qualified personnel following recognized procedures and using transfer standards traceable to NRC/NIST.

Equipment: Magnetic Dipole

Manufacturer: APREL Laboratories

Model No.: TMFS-1

Serial No.: 01152

Calibration Procedure: SSI/DRB-TP-MD-037

Project No: INTERNAL

Calibrated: 22nd June 2006
 Released on: 22nd June 2006

This Calibration Certificate is Incomplete Unless Accompanied with the Calibration Results Summary

Released By: _____

NCL CALIBRATION LABORATORIES

51 SPECTRUM WAY
 NEPEAN, ONTARIO
 CANADA K2R 1E6

Division of APREL Lab.
 TEL: (613) 820-4988
 FAX: (613) 820-4161

Introduction

This Calibration Report reproduces the results of the calibration performed in line with the SSI/DRB-TP-MD-037 Calibration Procedure.

Conditions

01152 was a re-calibration.

Ambient Temperature of the Laboratory: 22 °C +/- 0.5°C

We the undersigned attest that to the best of our knowledge the calibration of this Magnetic Dipole has been accurately conducted and that all information contained within the results pages have been reviewed for accuracy.

Stuart Nicol

Liguo Yang

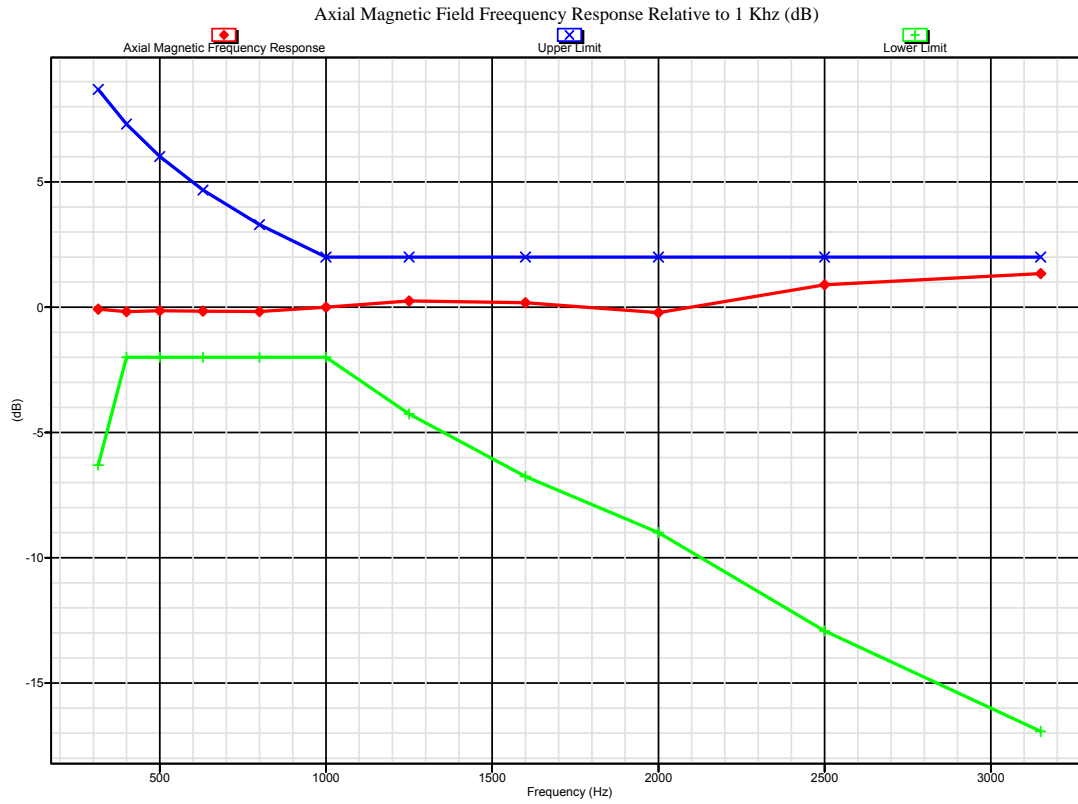

Frequency Response Maximum = 1.34dB @ 3150Hz
Frequency Response Minimum = -0.22dB @ 2000Hz

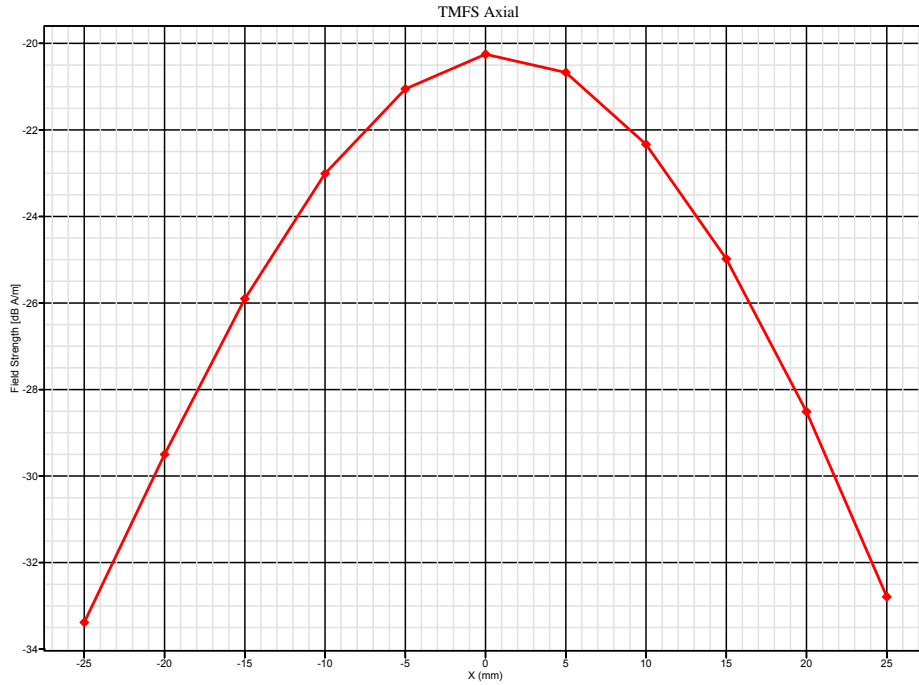

Maximum Axial at 0mm = -19.78 [dB(A/m)]

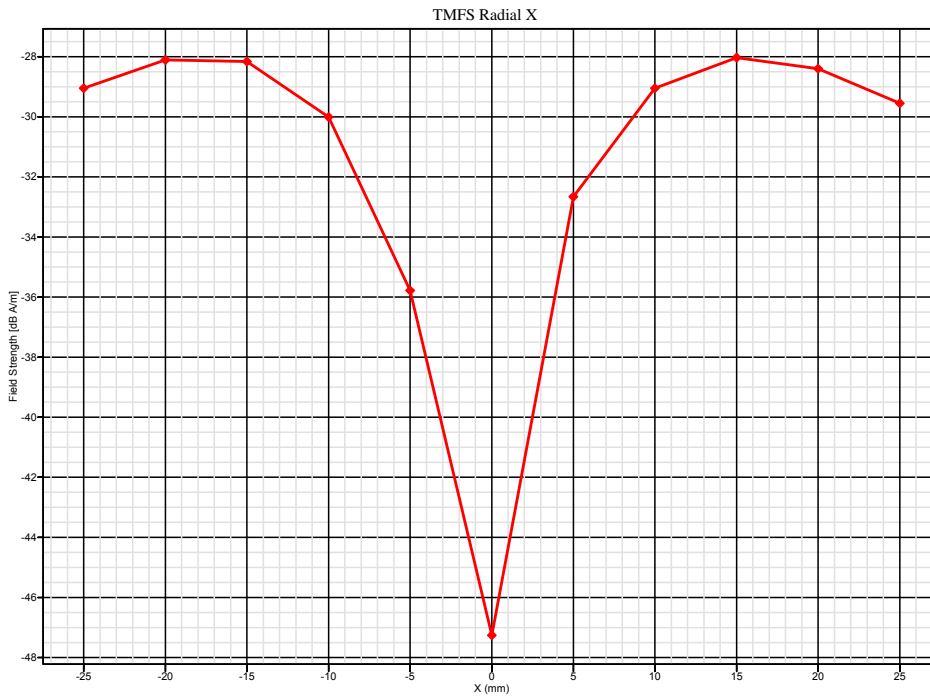

Minimum Radial at 0mm X = -61.45 [dB(A/m)]

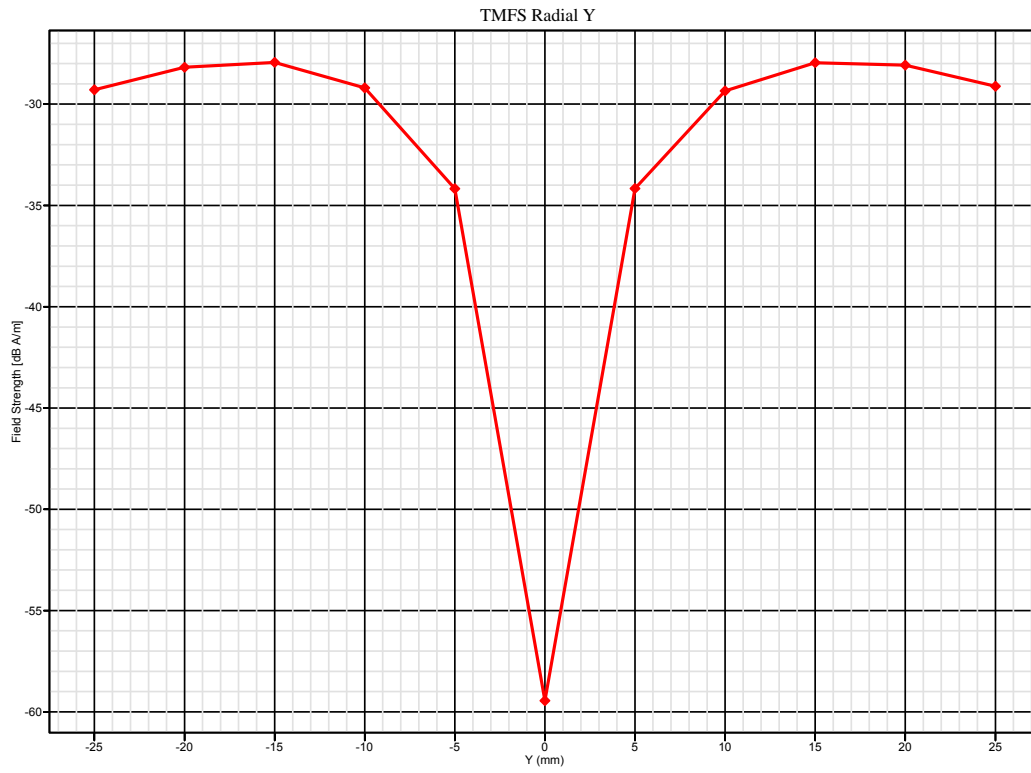

Minimum Radial at 0mm Y = -59.45 [dB(A/m)]

TMFS 01152 Magnetic Field Resultant Data

Axial X

Horizontal position	H-field
[mm]	[dB(A/m)]
-25	-31.35
-20	-27.89
-15	-24.56
-10	-21.97
-5	-20.34
0	-19.78
5	-20.58
10	-22.45
15	-25.34
20	-29.01
25	-33.16

Radial X

Radial Y

Horizontal position	Horizontal position	H-field	H-field
[mm]	[dB(A/m)]	[mm]	[dB(A/m)]
-25	-28.4	-25	-29.47
-20	-27.55	-20	-28.66
-15	-27.49	-15	-28.51
-10	-29.19	-10	-30.01
-5	-34.16	-5	-34.99
0	-61.46	0	-59.45
5	-32.89	5	-34.87
10	-27.45	10	-30.04
15	-27.23	15	-28.53
20	-27.56	20	-28.56
25	-28.78	25	-29.45

NCL CALIBRATION LABORATORIES

Calibration File No.: TC-709

Client: APREL Laboratories

CERTIFICATE OF CALIBRATION

It is certified that the equipment identified below has been calibrated in the **NCL CALIBRATION LABORATORIES** by qualified personnel following recognized procedures and using transfer standards traceable to NRC/NIST.

Equipment: Twin Axis T-Coil Probe

Manufacturer: APREL Laboratories

Model No.: ALS-T-020

Serial No.: T-020-101

Calibration Procedure: SSI/DRB-TP-TTP-01

Project No: INTERNAL

Calibrated: 22nd June 2006

Released on: 22nd June 2006

This Calibration Certificate is Incomplete Unless Accompanied with the Calibration Results Summary

Released By: _____

NCL CALIBRATION LABORATORIES

51 SPECTRUM WAY
NEPEAN, ONTARIO
CANADA K2R 1E6

Division of APREL Lab.
TEL: (613) 820-4988
FAX: (613) 820-4161

Introduction

This Calibration Report reproduces the results of the calibration performed in line with the SSI/DRB-TP-TTP-01 Calibration Procedure.

Conditions

T-020-101 was a new probe taken from stoke for calibration.

Ambient Temperature of the Laboratory: 22 °C +/- 0.5°C

We the undersigned attest that to the best of our knowledge the calibration of this Magnetic Dipole has been accurately conducted and that all information contained within the results pages have been reviewed for accuracy.

Stuart Nicol

Liguo Yang

Probe Sensitivity

Helmholtz Coil Calibration

The sensitivity for probe T-020-101 was determined through exposure to the magnetic field from a Helmholtz coil as per the specification contained in C63.19 2006.

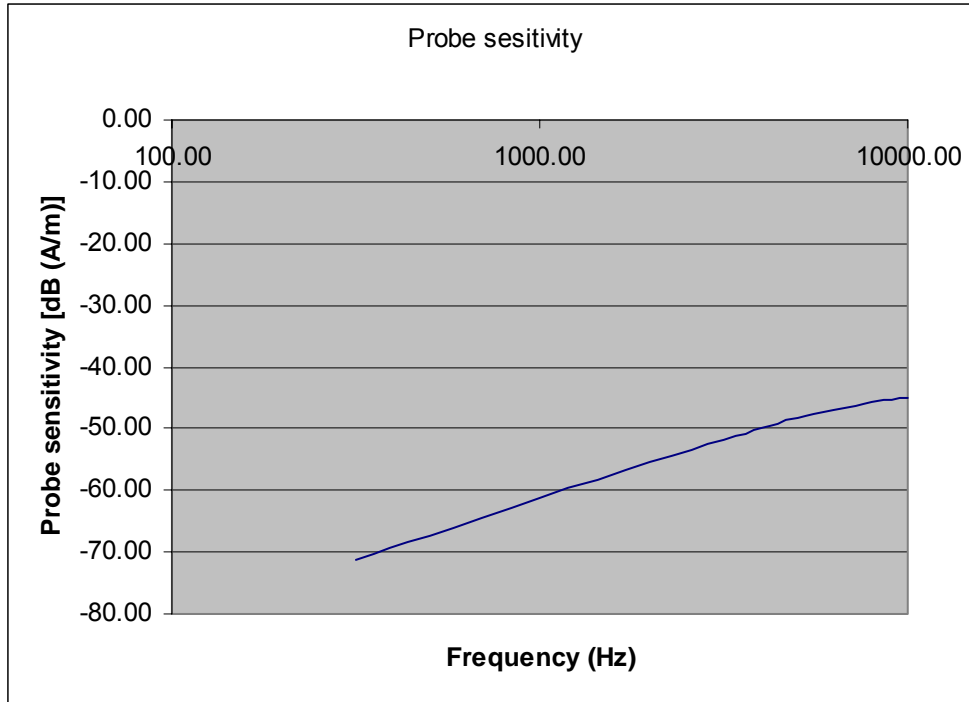

T-Coil Probe Sensitivity @ 1kHz: -61.26

Probe Frequency Response

Magnetic Dipole Calibration

The frequency response for probe T-020-101 was measured using the APREL Laboratories Magnetic Dipole™ as per the requirements in C63.19 2006.

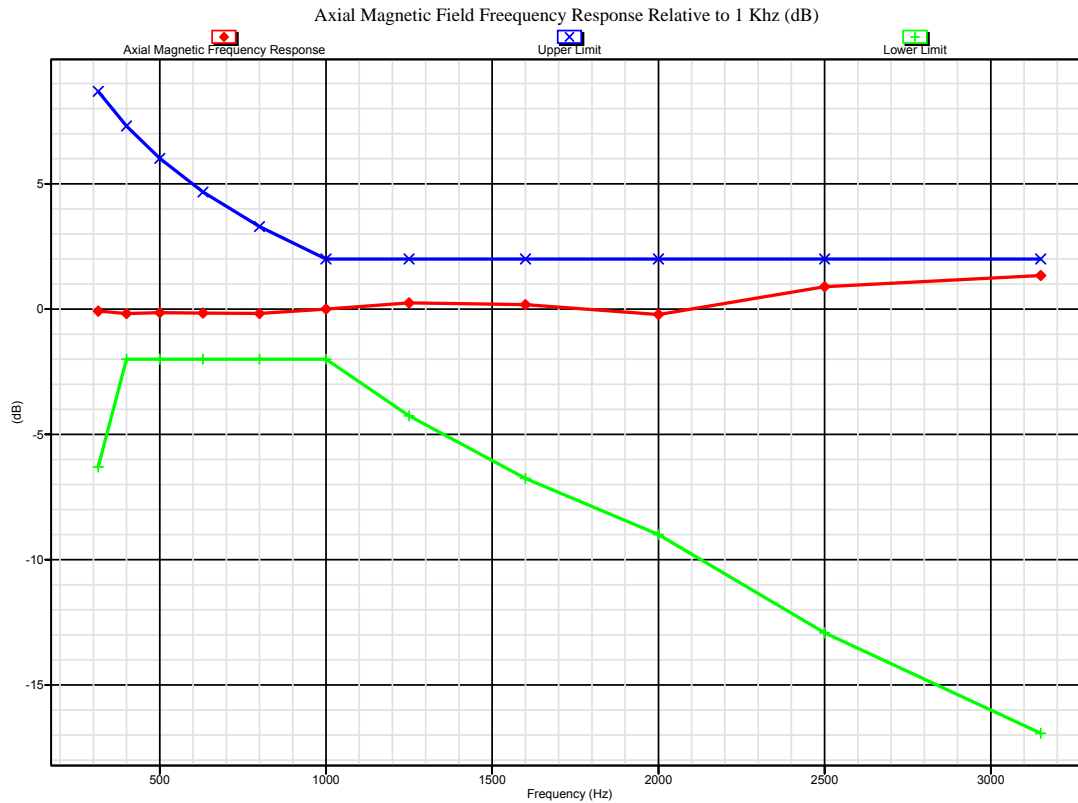

Frequency Response Maximum = 1.34dB @ 3150Hz
Frequency Response Minimum = -0.22dB @ 2000Hz