

**Exhibit 2**

General Information – Operation Description

1. Production Plans

Quantity Production Planned

2. Technical Description - Section 2.1033 (c)

(1) The full name and mailing address of the manufacturer of the device and the applicant

Applicant: Kyocera Wireless Corporation  
10300 Campus Point Drive  
San Diego, CA 92121

Manufacture: Kyocera Wireless Corporation  
10300 Campus Point Drive  
San Diego, CA92121

(2) FCC Identifier

FCC ID: OVFKWC-3225

(3) User's Manual

See exhibit 20

(4) Types of Emission

40K0F8W  
40K0F1D  
1M25F9W

F3E voice  
F3D supervisory audio tones, signaling tones  
F1D wideband data signal

(5) Frequency range

The frequency range of the equipment in Domestic Public Cellular Radio Telecommunications Service bands, 824 - 849 MHz and 869 - 894 MHz for FM and cellular CDMA. The channel spacing is 30 kHz for FM.

The frequency range of the equipment in the Personal Communications Services (PCS) bands, 1850 – 1910 MHz and 1930 – 1990 MHz. The channel spacing is 1.25 MHz for CDMA.

(6) Operating power levels

The transmitter output power is independent of whether the equipment operates in the cellular system FM or CDMA mode, or PCS system CDMA mode. The equipment supports Class 3 Cellular Mobile Station Power Class, and Class 2 PCS Mobile Station Power Class. Its power output capability is reported to the Land Station via Station Class Mark. The equipment will respond to commands from

the Land Station to change power levels as defined in the EIA/TIA/IS-98 and ANSI J-STD-018 Specification.

(7) Maximum output power

The equipment supports the maximum output power for Class 3 Cellular Mobile Station which is -2 dBW ERP for a FM mode and in the range of -7 dBW to 0 dBW ERP for a CDMA mode, and meets the 7 W ERP (+8.45 dBW) maximum power limitation of Section 22.913.

The equipment supports the maximum output power for Class 2 PCS Mobile Station which is in the range of -7dBW to 0 dBW EIRP, and is within the limited 2 watts E.I.R.P. peak power of CFR 47 Part 24.232 (b). The equipment is able to limit the output power to the minimum necessary for successful communications.

(8) Final RF amplifying device power consumption

The equipment is powered by lithium ion rechargeable batteries which have a voltage range of 3.2 to 4.2 Vdc.

In the Cellular band, the power consumption of the high power amplifier is about 27.8dBm in a CDMA mode and about 28.8dBm in a FM mode. In the PCS band, the power consumption of the high power amplifier is about 26.4dBm.

(9) Tune-up procedure over the power range

All frequency and power adjustments are set at the factory and there are no field adjustments for this product. Under digital mode, the frequency is locked to the base station and controlled by VCTCXO adjustments to offset any possible errors. Note: Digital mode encompasses the mobiles CDMA and FM operation. In CDMA, the carrier frequency error combiner combines the frequency error estimates of all in-lock demodulating fingers, and filters the result. This result drives a PDM circuit, which in turn yields a voltage that corrects the frequency of the VCTCXO. In FM, also referred to as digital FM, the frequency tracking loop circuit calculates the rate of rotation. This rate of rotation corresponds to the frequency error. This frequency error signal is filtered. This result drives a PDM circuit, which in turn yields a voltage that corrects the frequency of the VCTCXO.

(10) Circuit description

(a) Circuit diagram and list of semiconductor device

See exhibit 16 and 17.

(b) Circuit description for frequency determining and stabilizing

The circuit provided for determining and stabilizing frequency is in exhibit 17.

A voltage controlled, temperature compensated, crystal oscillator (VCTCXO) is employed as a frequency reference for all of the transceiver local oscillators. This crystal oscillator is specified to remain within +/- 2.5 ppm over temperature and voltage variations. The lock status indicator of all synthesizers is monitored by the microprocessor and an out of lock condition will inhibit transmission. In all modes, the mobile receiver monitors the received signal and adjusts the frequency of the VCTCXO, this corrects any errors between the mobile frequency and the base station transmitter. The mobile is locked to the base station.

(c) Circuit description for spurious radiation suppression

The circuit provided for suppression of spurious radiation is in exhibit 17.

The transmitter front end provides filtering of the RF signal in order to meet FCC specifications. For radiated spurious suppression, proper design techniques and the use of proper shielding techniques reduced the emission levels well below the permissible FCC limit.

(d) Circuit description for limiting modulation

The circuit provided for limiting modulation is in exhibit 17.

*AMPS Mode*

The F3E audio modulation is accomplished through the use of Digital Signal Processor (DSP). Audio samples are output from the DFM block at 120Ksps. These samples are converted to 2's complement form, Interpotated to 480Ksps rate , FM modulated, and Interpolated to the VCTCXO rate. The filtering and modulator require the VCTCXO clock along with the different enables, 120KHz, 240KHz, and 480KHz, all of which are generated from the VCTCXO reference.

*CDMA Mode when operating in a P\_REV 5 or less network*

The CDMA mode described in the following pages is from the TIA/EIA/IS-95B Standard. The justification for the CDMA bandwidth of 1.25 MHz is that the chip rate is 1.2288 MHz. The 1.25MHz is measured at the 3dB down bandwidth. Channel spacing is normally set at this 1.25 MHz. In addition the reference baseband filtering requirements are shown in Section 6.1.3.10, Baseband Filtering of IS95B. The filter coefficients for the recommended baseband filter are listed in Table 6.1.3.10-1. These values yield the "necessary bandwidth" of 1.25 MHz based on optimal detection and channel capacity theory.

### 6.1.3 Modulation Characteristics

#### 6.1.3.1 Reverse CDMA Channel Signals

The Reverse CDMA Channel is composed of Access Channels and Reverse Traffic Channels. These channels shall share the same CDMA frequency assignment using direct-sequence CDMA techniques. Figure 6.1.3.1-1 shows an example of all of the signals received by a base station on the Reverse CDMA Channel. Each Traffic Channel is identified by a distinct user long code sequence; each Access Channel is identified by a distinct Access Channel long code sequence. Multiple Reverse CDMA Channels may be used by a base station in a frequency division multiplexed manner.

The Reverse CDMA Channel has the overall structure shown in Figure 6.1.3.1-2. Data transmitted on the Reverse CDMA Channel is grouped into 20 ms frames. All data transmitted on the Reverse CDMA Channel is **convolutionally** encoded, block interleaved, modulated by the **64-ary** orthogonal modulation, and direct-sequence spread prior to transmission.

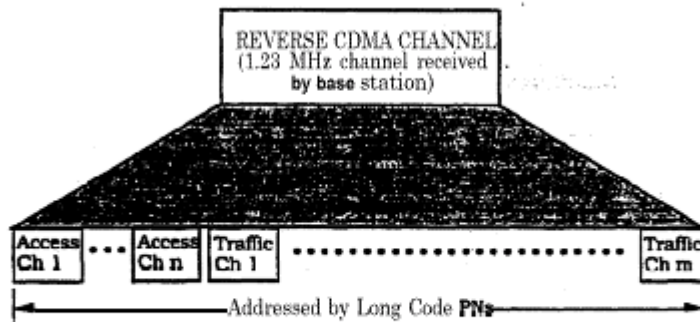

Figure 6.1.3.1-1. Example of Logical Reverse CDMA Channels Received at a Base Station

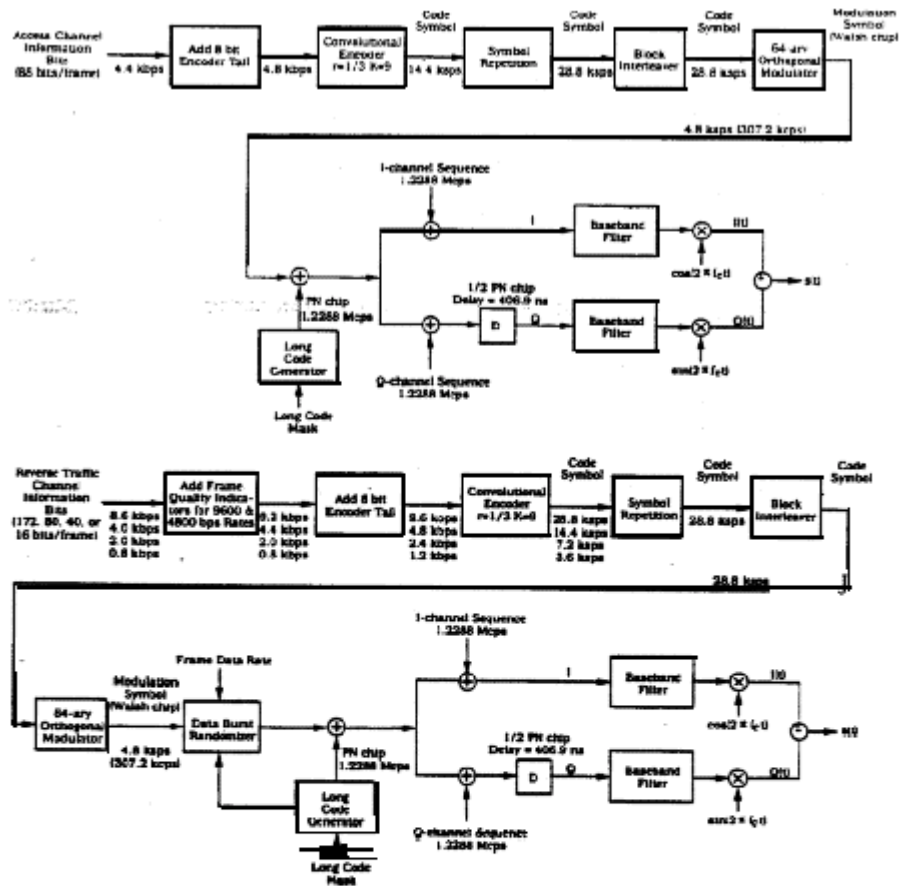

Figure 6.1.3.1-2. Reverse CDMA Channel Structure

After adding frame quality indicators for both the 9600 bps and 4800 bps rates (see 6.1.3.3.2.1) and adding eight Encoder Tail Bits (see 6.1.3.3.2.2), data frames may be transmitted on the Reverse **Traffic** Channel at data rates of 9600, **4800**, **2400**, and 1200 bps. The Reverse **Traffic** Channel may use any of these **data** rates for transmission. The transmission duty cycle on the Reverse Traffic Channel varies with the transmission data rate. Specifically, the transmission duty cycle for 9600 bps frames is 100 percent, the transmission duty cycle for 4800 bps frames is 50 percent, the transmission duty cycle for 2400 bps frames is 25 percent, and the **transmission** duty cycle for 1200 bps frames is 12.5 percent as shown in Table 6.1.3.1.1-1. As the duty cycle for transmission varies **proportionately** with the data rate, the actual burst transmission rate is fixed at 28.800

code symbols per second. Since ~~six~~ code symbols are modulated as one of 64 modulation symbols for transmission, the modulation ~~symbol~~ transmission rate is fixed at 4800 modulation symbols per second. This results in a ~~fixed~~ Walsh chip rate of 307.2 kcps. The rate of the spreading PN sequence is fixed at 1.2288 Mcps, so that each Walsh chip is spread by four PN chips. Table 6.1.3.1.1-1 defines the signal rates and their relationship for the various transmission rates on the Reverse Traffic Channel.

The numerology is identical for the Access Channel except that the transmission rate is ~~fixed~~ at 4800 bps after adding eight Encoder Tail Bits (see 6.1.3.2.2). Each code symbol is repeated once, and the transmission duty cycle is 100 percent. Table 6.1.3.1.1-2 defines the signal rates and their relationship on the Access Channel.

#### 6.1.3.1.1 Modulation Parameters

The modulation parameters for the Reverse Traffic Channel and the Access Channel are shown in Table 6.1.3.1.1-1 and Table 6.1.3.1.1-2, respectively.

**Table 6.1.3.1.1-1. Reverse Traffic Channel Modulation Parameters**

Parameter	Data Rate (bps)				Units
	9600	4800	2400	1200	
PN Chip Rate	1.2288	1.2288	1.2288	1.2288	Mcps
Code Rate	1/3	1/3	1/3	1/3	bits/code sym
Transmit Duty Cycle	100.0	50.0	25.0	12.5	%
Code Symbol Rate	28,800	28,800	28,800	28,800	sps
Modulation	6	6	6	6	code sym/mod symbol
Modulation Symbol Rate	4800	4800	4800	4800	sps
Walsh Chip Rate	307.20	307.20	307.20	307.20	kcps
Mod Symbol Duration	208.33	208.33	208.33	208.33	μs
PN Chips/Code Symbol	42.67	42.67	42.67	42.67	PN chip/code symbol
PN Chips/Mod symbol	256	256	256	256	PN chip/mod symbol
PN Chips/Walsh Chip	4	4	4	4	PN chips/Walsh chip

*CDMA MODE when operating in a P\_REV 6 or above Network*

The CDMA mode described in the following pages is from IS-2000.2 Standard, Release 0, dated 24-April-2001. This specification is also known by the 3GPP2 Group as : *Physical Layer Standard for cdma2000 Spread Spectrum Systems, 3GPP2 C.S0002-0-2, Version 1.13*. This particular mobile can only invoke a Spreading Rate 1 operational mode. This term, Spreading Rate 1, by definition limits the bandwidth to the same 1.25MHz bandwidth occupied by the legacy IS-95/8-A/B systems. More specifically, Spreading Rate 1 is defined as a 1.2288 Mcps chip rate-based system using a direct-spread single carrier. In addition, the reference baseband filtering requirements are shown in Section 2.1.3.1.13, Baseband Filtering. The associated filter coefficients listed in Table 2.1.3.1.13.1-1 are identical to those listed in IS-95. Thus, for Spreading Rate 1 in IS-2000, the frequency response is identical to the legacy IS-95B system standard, where it was shown that these values yield the “necessary bandwidth” of 1.25 MHz based upon optimal detection and channel capacity theory.

## 2.1.3 Modulation Characteristics when operating in a P\_REV 6 or above Network

The IS2000.2 standard details all of the possible radio configurations, channel types, frame lengths, and encoding schemes, associated with reverse channel for Spreading Rate 1 as well as Spreading Rate 3. As previously stated, the microprocessor resident in the KWC-3225 handset is limited to Spreading Rate 1 chip rates. Furthermore, this microprocessor is also limited to following on the Reverse Link:

- Radio Configurations and Channel Types
- RC3 – RC4 for the Pilot Channel, R-PICH
- RC1 – RC4 for the Fundamental Channel, R-FCH
- RC3-RC4 for the Supplemental Channel, R-SCH
  - RC3 maximum data rate is 153600bps
  - RC4 maximum data rate is 115200bps
- RC1 – RC4 for the Access Channel, R-ACH
- 20msec frames only, (no support for 5msec, 40msec, or 80msec frames)
- Convolutional and Turbo Encoding

To aid in the understanding, of which channels are supported by the microprocessor resident in the KWC-3225, a Figure from IS-2000.2 is presented below. In this Figure, the non-supported items have been crossed out. This clearly demonstrates which types of channels the mobile is not capable of generating on the reverse link.

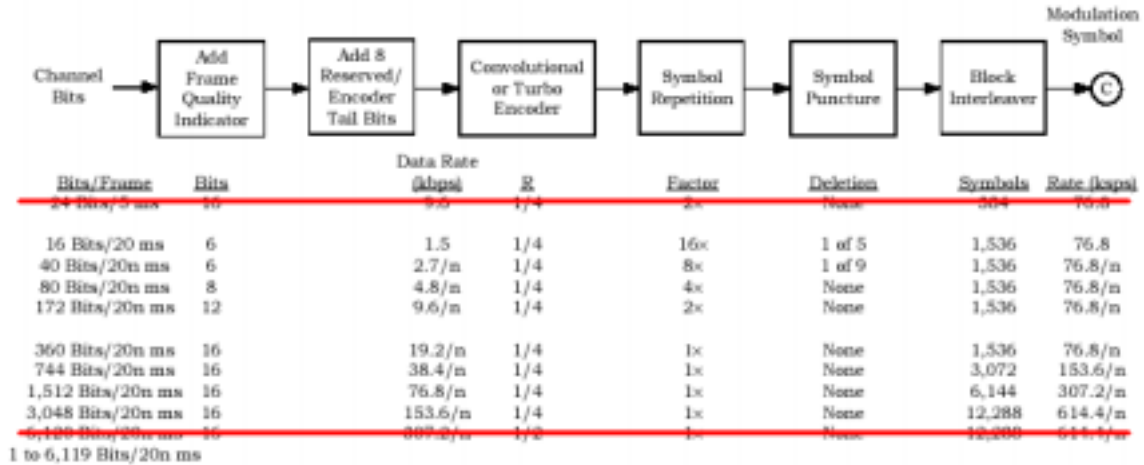

**Figure 2.1.3.1.1-1. Reverse CDMA Channels Received at the Base Station**

For Radio Configurations 1 and 2, the creation of  $s(t)$  nets an identical waveform to the waveform created in the legacy IS-95B system / standard. Thus, backwards compatibility is insured. For Radio Configurations 3 and 4,  $s(t)$  differs in a manner that is detailed below. Note, even though the composite waveform differs, the resultant is still based upon Spreading Rate 1 using the direct-sequence CDMA technique. Thus the 3dB bandwidth is still 1.25MHz, and all of the channels share the same CDMA frequency assignment, as in the legacy 95B system.

The following Pictures detailing the RC3 and RC4 Channel creating structures





- Notes:
- n is the length of the frame in multiples of 20 ms. For 31 to 54 encoder input bits per frame, n = 1, 2, or 4.
  - ~~The 5 ms frame is only used for the Reverse Fundamental Channel, and the Reverse Fundamental Channel only uses 15 to 192 encoder input bits per frame with n = 1.~~
  - Turbo coding may be used for the Reverse Supplemental Channels with 384 or more encoder input bits per frame; otherwise, K = 9 convolutional coding is used.
  - With convolutional coding, the Reserved/Encoder Tail bits provide an encoder tail. With turbo coding, the first two of these bits are reserved bits that are encoded and the last six bits are replaced by an internally generated tail.
  - If variable-rate Reverse Supplemental Channel operation, flexible reverse link data rates, or both are supported, the parameters are determined from the specified number of channel bits per frame, the maximum assigned number of channel bits per frame for the Reverse Fundamental Channel or the Reverse Supplemental Channel, and the specified frame quality indicator length.
    - The frame quality indicator length is 16 for more than 192 encoder input bits per frame; 12 or 16 for 97 to 192 encoder input bits per frame; 8, 12, or 16 for 55 to 96 encoder input bits per frame; and 6, 8, 12, or 16 otherwise.
    - The code rate is 1/2 for more than 3,072 encoder input bits per frame; otherwise, it is 1/4. If the number of encoder input bits per frame is less than 384, the type of encoding is convolutional; otherwise, it is the same as that of the maximum assigned data rate for the channel.
    - If the specified number of channel bits per frame is equal to the maximum assigned number of channel bits per frame and that number and the specified frame quality indicator length match one of the listed cases, the symbol repetition factor and symbol puncturing from that listed case are used. Otherwise, the symbol repetition factor and puncturing are calculated to achieve the same interleaver block size as for the maximum assigned data rate for the channel.
    - If the maximum assigned data rate matches one of the data rates listed in the figure, the interleaver block size for that listed data rate is used. Otherwise, the interleaver block size of the next higher listed data rate is used.

**Figure 2.1.3.1.1-8. Reverse Fundamental Channel and Reverse Supplemental Channel Structure for Radio Configuration 3**

Note: The OVFKWC-3225 does not support 5msec frames, and it is limited to 153.6kbps on the RL for RC3

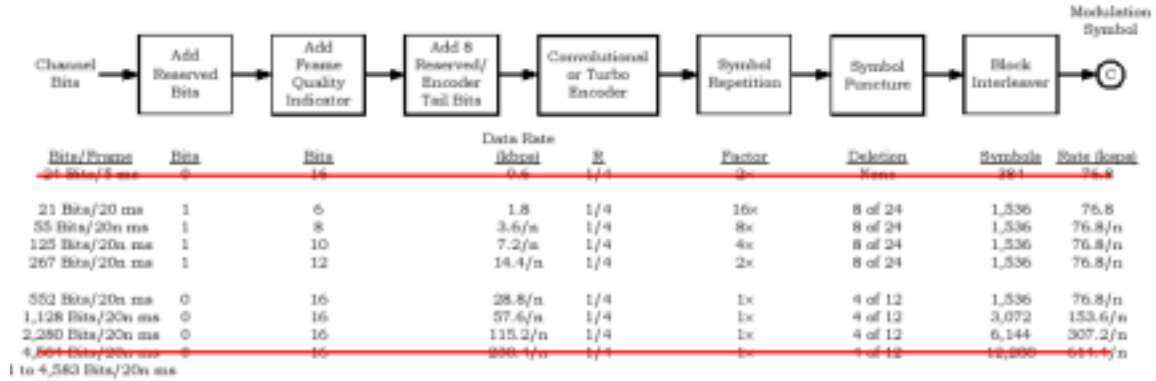

- Notes:
- n is the length of the frame in multiples of 20 ms. For 37 to 72 encoder input bits per frame, n = 1 or 2. For more than 72 encoder input bits per frame, n = 1, 2, or 4.
  - ~~The 5 ms frame is only used for the Reverse Fundamental Channel, and the Reverse Fundamental Channel only uses 16 to 288 encoder input bits per frame with n = 1.~~
  - Turbo coding may be used for the Reverse Supplemental Channels with 576 or more encoder input bits per frame; otherwise, K = 9 convolutional coding is used.
  - With convolutional coding, the Reserved/Encoder Tail bits provide an encoder tail. With turbo coding, the first two of these bits are reserved bits that are encoded and the last six bits are replaced by an internally generated tail.
  - If variable-rate Reverse Supplemental Channel operation, flexible reverse link data rates, or both are supported, the parameters are determined from the specified number of channel bits per frame, the maximum assigned number of channel bits per frame for the Reverse Fundamental Channel or the Reverse Supplemental Channel, and the specified frame quality indicator length.
    - When the number of channel bits per frame is 21, 55, 125, or 267 and the corresponding number of frame quality indicator bits is 6, 8, 10, and 12, an initial reserved bit is used; otherwise, no initial reserved bits are used.
    - The frame quality indicator length is 16 for more than 288 encoder input bits per frame; 12 or 16 for 145 to 288 encoder input bits per frame; 10, 12, or 16 for 73 to 144 encoder input bits per frame; 8, 10, 12, or 16 for 37 to 72 encoder input bits per frame; and 6, 8, 10, 12, or 16 otherwise.
    - The code rate is 1/4. If the number of encoder input bits per frame is less than 576, the type of encoding is convolutional; otherwise, it is the same as that of the maximum assigned data rate for the channel.
    - If the specified number of channel bits per frame is equal to the maximum assigned number of channel bits per frame and that number and the specified frame quality indicator length match one of the listed cases, the symbol repetition factor and symbol puncturing from that listed case are used. Otherwise, the symbol repetition factor and puncturing are calculated to achieve the same interleaver block size as for the maximum assigned data rate for the channel.
    - If the maximum assigned data rate matches one of the data rates listed in the figure, the interleaver block size for that listed data rate is used. Otherwise, the interleaver block size of the next higher listed data rate is used.

**Figure 2.1.3.1.1-9. Reverse Fundamental Channel and Reverse Supplemental Channel Structure for Radio Configuration 4**

Note: The OVFKWC-3225 does not support 5msec frames, and it is limited to 115.2kbps on the RL for RC4

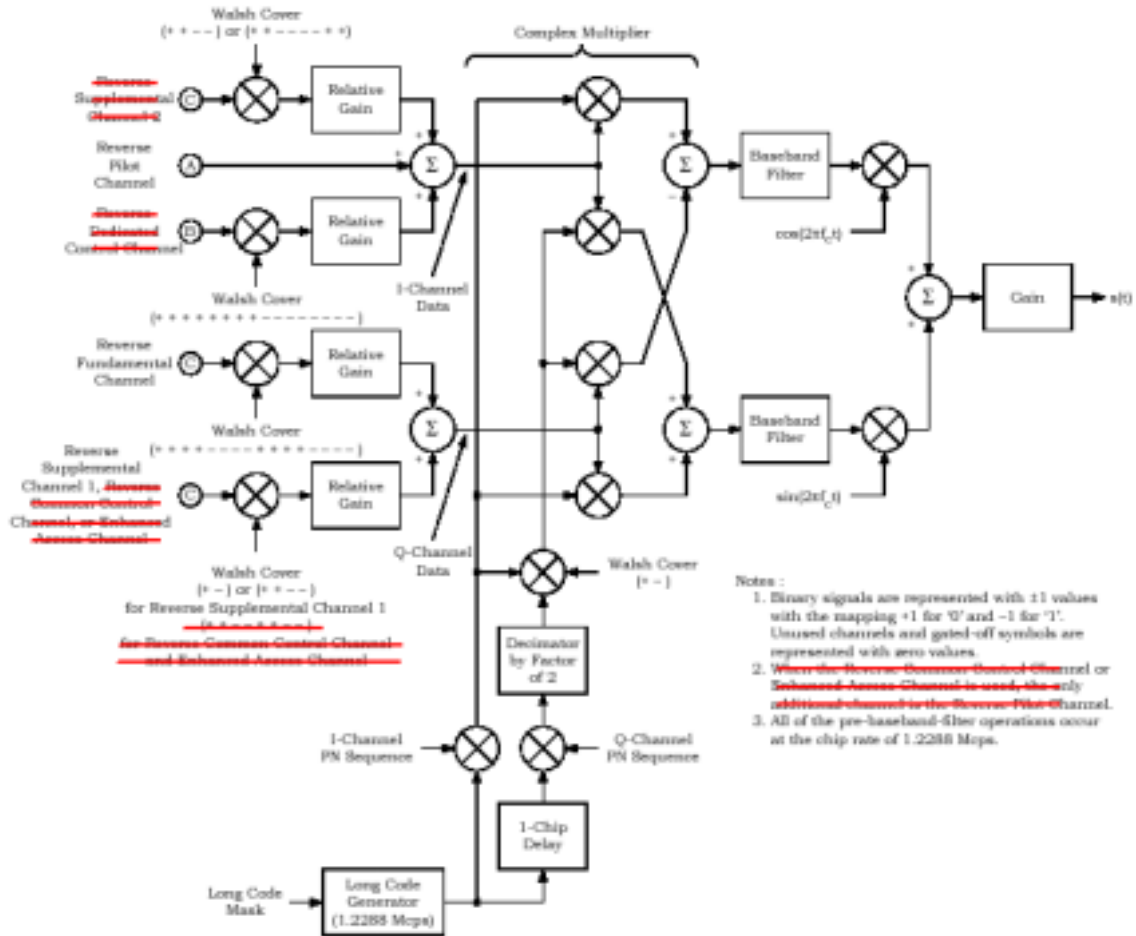

**Figure 2.1.3.1.1.1-10. I and Q Mapping for Reverse Pilot Channel, Enhanced Access Channel, Reverse Common Control Channel, and Reverse Traffic Channel with Radio Configurations 3 and 4**

Note: The OVFKWC-3225 does R-SCH2, R-DCCH, R-CCCH, or R-EACH

## 2.1.3.1.2 Modulation Parameters when operating in a P\_REV 6 or above Network

The modulation parameters for the Reverse CDMA Channel operating in Spreading Rate 1 are shown in the following Tables. Note, only the Tables supported by the microprocessor contained in the KWC-3225 are provided. Furthermore, within these tables, some additional non-supported items are line-striked to indicate the KWC-3225 Handset does not support.

**Table 2.1.3.1.2.1-1. Access Channel Modulation Parameters for Spreading Rate 1**

Parameter	Data Rate (bps)	Units
	4,800	
PN Chip Rate	1.2288	Mcps
Code Rate	1/3	bits/code symbol
Code Symbol Repetition	2	repeated code symbols/code symbol
Repeated Code Symbol Rate	28,800	sps
Modulation	6	repeated code symbols/modulation symbol
Modulation Symbol Rate	4800	sps
Walsh Chip Rate	307.20	kcps
Modulation Symbol Duration	208.33	μs
PN Chips/Repeated Code Symbol	42.67	PN chips/repeated code symbol
PN Chips/Modulation Symbol	256	PN chips/modulation symbol
Transmit Duty Cycle	100.0	%
PN Chips/Walsh Chip	4	PN chips/Walsh chip

**Table 2.1.3.1.2.1-6. Reverse Fundamental Channel and Reverse Supplemental Code Channel Modulation Parameters for Radio Configuration 1**

Parameter	Data Rate (bps)				Units
	9,600	4,800	2,400	1,200	
PN Chip Rate	1.2288	1.2288	1.2288	1.2288	Mcps
Code Rate	1/3	1/3	1/3	1/3	bits/code symbol
Code Symbol Repetition	1	2	4	8	repeated code symbols/code symbol
Repeated Code Symbol Rate	28,800	28,800	28,800	28,800	sps
Modulation	6	6	6	6	repeated code symbols/modulation symbol
Modulation Symbol Rate	4,800	4,800	4,800	4,800	sps
Walsh Chip Rate	307.20	307.20	307.20	307.20	kcps
Modulation Symbol Duration	208.33	208.33	208.33	208.33	μs
PN Chips/Repeated Code Symbol	42.67	42.67	42.67	42.67	PN chips/repeated code symbol
PN Chips/Modulation Symbol	256	256	256	256	PN chips/modulation symbol
PN Chips/Walsh Chip	4	4	4	4	PN chips/Walsh chip
Transmit Duty Cycle	100.0	50.0	25.0	12.5	%
Processing Gain	128	128	128	128	PN chips/bit

Note: The 1200, 2400, and 4800 bps data rates are applicable to the Reverse Fundamental Channel only.

**Table 2.1.3.1.2.1-7. Reverse Fundamental Channel and Reverse Supplemental Code Channel Modulation Parameters for Radio Configuration 2**

Parameter	Data Rate (bps)				Units
	14,400	7,200	3,600	1,800	
PN Chip Rate	1.2288	1.2288	1.2288	1.2288	Mcps
Code Rate	1/2	1/2	1/2	1/2	bits/code symbol
Code Symbol Repetition	1	2	4	8	repeated code symbols/code symbol
Repeated Code Symbol Rate	28,800	28,800	28,800	28,800	sps
Modulation	6	6	6	6	repeated code symbols/modulation symbol
Modulation Symbol Rate	4,800	4,800	4,800	4,800	sps
Walsh Chip Rate	307.20	307.20	307.20	307.20	kcps
Modulation Symbol Duration	208.33	208.33	208.33	208.33	μs
PN Chips/Repeated Code Symbol	42.67	42.67	42.67	42.67	PN chips/repeated code symbol
PN Chips/Modulation Symbol	256	256	256	256	PN chips/modulation symbol
PN Chips/Walsh Chip	4	4	4	4	PN chips/Walsh chip
Transmit Duty Cycle	100.0	50.0	25.0	12.5	%
Processing Gain	85.33	85.33	85.33	85.33	PN chips/bit

Note: The 1800, 3600, and 7200 bps data rates are applicable to the Reverse Fundamental Channel only.

**Table 2.1.3.1.2.1-8. Reverse Fundamental Channel and Reverse Supplemental Channel Modulation Parameters for 20 ms Frames for Radio Configuration 3**

Parameter	Data Rate (bps)				Units
	9,600 × N	4,800	2,700	1,500	
PN Chip Rate	1.2288	1.2288	1.2288	1.2288	Mcps
Code Rate	1/4 (N < 32) <del>1/2 (N = 32)</del>	1/4	1/4	1/4	bits/code symbol
Code Symbol Repetition	2 (N = 1) 1 (N > 1)	4	8	16	repeated code symbols/code symbol
Puncturing Rate	1	1	8/9	4/5	interleaver symbols/repeated code symbol
Modulation Symbol Rate	76,800 (N ≤ 2) 38,400 × N (N = 4 or 8) <del>614,400 (N = 16)</del>	76,800	76,800	76,800	sps
Walsh Length	For Reverse Fundamental Channel: 16 For Reverse Supplemental Channel: 8, 4, or 2 (N ≤ 4) 4 or 2 (N = 8) <del>2 (N ≥ 16)</del>	16 (Reverse Fundamental Channel) 8, 4, or 2 (Reverse Supplemental Channel)			PN chips
Number of Walsh Function Repetitions per Modulation Symbol	For Reverse Fundamental Channel: 1 For Reverse Supplemental Channel: 2, 4, or 8 (N ≤ 2) 1, 2, or 4 (N = 4) 1 or 2 (N = 8) 1 (N ≥ 16)	1 (Reverse Fundamental Channel) 2, 4, or 8 (Reverse Supplemental Channel)			Walsh functions/modulation symbol
Transmit Duty Cycle	100.0	100.0	100.0	100.0 or 50.0	%
Processing Gain	128/N	256	455.1	819.2	PN chips/bit

Note:

1. N = 1, 2, 4, 8, ~~16, or 32~~, which yields data rates of 9600, 19200, 38400, 76800, ~~153600, or 307200~~ bps, respectively.
2. The 50% transmit duty cycle at 1500 bps data rate corresponds to the Reverse Fundamental Channel gating.

**Table 2.1.3.1.2.1-11. Reverse Fundamental Channel and Reverse Supplemental Channel Modulation Parameters for 20 ms Frames for Radio Configuration 4**

Parameter	Data Rate (bps)				Units
	14,400 × N	7,200	3,600	1,800	
PN Chip Rate	1.2288	1.2288	1.2288	1.2288	Mcps
Code Rate	1/4	1/4	1/4	1/4	bits/code symbol
Code Symbol Repetition	2 (N = 1) 1 (N > 1)	4	8	16	repeated code symbols/code symbol
Puncturing Rate	16/24 (N = 1) 8/12 (N > 1)	16/24	16/24	16/24	interleaver symbols/ repeated code symbol
Modulation Symbol Rate	76,800 (N = 1) 38,400 × N (N ≥ 2)	76,800	76,800	76,800	sps
Walsh Length	For Reverse Fundamental Channel: 16 For Reverse Supplemental Channel: 8, 4, or 2 (N ≤ 4) 4 or 2 (N = 8) <del>2 (N = 16)</del>	16 (Reverse Fundamental Channel) 8, 4, or 2 (Reverse Supplemental Channel)			PN chips
Number of Walsh Function Repetitions per Modulation Symbol	For Reverse Fundamental Channel: 1 For Reverse Supplemental Channel: 2, 4, or 8 (N ≤ 2) 1, 2, or 4 (N = 4) 1 or 2 (N = 8) <del>1 (N = 16)</del>	1 (Reverse Fundamental Channel) 2, 4, or 8 (Reverse Supplemental Channel)			Walsh functions/modulation symbol
Transmit Duty Cycle	100.0	100.0	100.0	100.0 or 50.0	%
Processing Gain	85.33/N	170.67	341.33	682.67	PN chips/bit

Notes:

1. N = 1, 2, 4, 8, or 16, which yields data rates of 14400, 28800, 57600, 115200, or ~~230400~~ bps, respectively.
2. If variable-rate Reverse Supplemental Channel operation, flexible reverse link data rates, or both are supported, the parameters are determined from the specified number of channel bits per frame, the maximum assigned number of channel bits per frame for the Reverse Fundamental Channel or the Reverse Supplemental Channel, and the specified frame quality indicator length.
3. The 50% transmit duty cycle at 1800 bps data rate corresponds to the Reverse Fundamental Channel gating.

Note: The OVFKWC-3225 is limited to 115200bps, thus 230400bps has been struck-out above



2.1.3.1.3 Data Rates

The data rates for channels operating with Spreading Rate 1 shall be as specified in Table 2.1.3.1.3-1. Note: Here again the channels, data rates, and frame sizes not supported by the KWC-3245 Handset have been line-striking in the Table 2.1.3.1.3-1

**Table 2.1.3.1.3-1. Data Rates for Spreading Rate 1**

Channel Type		Data Rates (bps)
Access Channel		4800
<del>Enhanced Access Channel</del>	Header	<del>9600</del>
	Data	<del>38400 (5, 10, or 20 ms frames), 19200 (10 or 20 ms frames), or 9600 (20 ms frames)</del>
<del>Reverse Common Control Channel</del>		<del>38400 (5, 10, or 20 ms frames), 19200 (10 or 20 ms frames), or 9600 (20 ms frames)</del>
<del>Reverse Dedicated Control Channel</del>	RC 3	<del>9600</del>
	RC 4	<del>14400 (20 ms frames) or 9600 (5 ms frames)</del>
Reverse Fundamental Channel	RC 1	9600, 4800, 2400, or 1200
	RC 2	14400, 7200, 3600, or 1800
	RC 3	9600, 4800, 2700, or 1500 (20 ms frames) <del>or 9600 (5 ms frames)</del>
	RC 4	14400, 7200, 3600, or 1800 (20 ms frames) <del>or 9600 (5 ms frames)</del>
Reverse Supplemental Code Channel	RC 1	9600
	RC 2	14400
Reverse Supplemental Channel	RC 3	<del>307200, 153600, 76800, 38400, 19200, 9600, 4800, 4800, 2700, or 1500 (20 ms frames) 153600, 76800, 38400, 19200, 9600, 4800, 2400, or 1200 (40 ms frames) 76800, 38400, 19200, 9600, 4800, 2400, or 1200 (80 ms frames)</del>
	RC 4	<del>230400, 115200, 57600, 28800, 14400, 7200, 3600, or 1800 (20 ms frames) 115200, 57600, 28800, 14400, 7200, 3600, or 1800 (40 ms frames) 57600, 28800, 14400, 7200, 3600, or 1800 (80 ms frames)</del>

Note: The OVFKWC-3225 does not support: R-EACH, R-DCCH, R-CCCH. Nor does it support 5msec, 40msec, or 80msec frames. Additionally, the data rates on the R-SCH are limited to the rates not line-striking above.

(e) Circuit description for limiting power

Transmitted power is monitored by a RF detector diode which is coupled from the Power Amplifier (PA) output. The detected DC voltage is fed into a microprocessor which uses a calibration table along with an offset correction and temperature correction table to control power limits. When the RF power exceeds a predetermined limit the gain of the stage preceding the PA is reduced.

(11) Photograph of the identification label

See Exhibit 18

(12) Photograph to reveal equipment construction and layout

See Exhibit 19