



RADIATED SPURIOUS EMISSIONS PORTIONS OF

**FCC CFR47 PART 22 SUBPART H
FCC CFR47 PART 24 SUBPART E
FCC CFR47 PART 27 SUBPART L
INDUSTRY CANADA RSS-132 ISSUE 2
INDUSTRY CANADA RSS-133 ISSUE 5
INDUSTRY CANADA RSS-139 ISSUE 2**

CERTIFICATION TEST REPORT

FOR

TRI BAND CDMA MOBILE PHONE WITH BLUETOOTH + EDR

**FCC MODEL NUMBER: K53-02
IC MODEL NUMBER: S2300**

**FCC ID: OVF-K5302
IC: 3572A-S2300**

REPORT NUMBER: 11U13921-3, REVISION B

ISSUE DATE: OCTOBER 06, 2011

Prepared for

**KYOCERA COMMUNICATIONS, INC
8611 BALBOA AVE
SAN DIEGO, CA 92123, U.S.A.**

Prepared by

**COMPLIANCE CERTIFICATION SERVICES (UL CCS)
47173 BENICIA STREET
FREMONT, CA 94538, U.S.A.
TEL: (510) 771-1000
FAX: (510) 661-0888**



NVLAP LAB CODE 200065-0

Revision History

<u>Rev.</u>	<u>Issue Date</u>	<u>Revisions</u>	<u>Revised By</u>
---	07/29/11	Initial Issue	T. Chan
B	10/06/11	Re-measured AWS & PCS Bands with Average Readings	T. Chan

1. ATTESTATION OF TEST RESULTS

COMPANY NAME: KYOCERA COMMUNICATIONS, INC
8611 BALBOA AVE
SAN DIEGO, CA 92123, U.S.A

EUT DESCRIPTION: TRI BAND CDMA MOBILE PHONE WITH BLUETOOTH + EDR

MODEL: S2300

SERIAL NUMBER: K1400000000102

DATE TESTED: JULY 21 TO 26, AUG 07, and OCT 3 – 4, 2011

APPLICABLE STANDARDS	
STANDARD	TEST RESULTS
FCC PART 22H, 24E, AND 27L	PASS (Radiated Portion)
IC RSS-132 ISSUE 2, RSS-133 ISSUE 5, AND RSS-139 ISSUE 2	PASS (Radiated Portion)

Compliance Certification Services, Inc. (UL CCS) tested the above equipment in accordance with the requirements set forth in the above standards. All indications of Pass/Fail in this report are opinions expressed by UL CCS based on interpretations and/or observations of test results. Measurement Uncertainties were not taken into account and are published for informational purposes only. The test results show that the equipment tested is capable of demonstrating compliance with the requirements as documented in this report.

Note: The results documented in this report apply only to the tested sample, under the conditions and modes of operation as described herein. This document may not be altered or revised in any way unless done so by UL CCS and all revisions are duly noted in the revisions section. Any alteration of this document not carried out by UL CCS will constitute fraud and shall nullify the document. This report must not be used by the client to claim product certification, approval, or endorsement by NVLAP, NIST, any agency of the Federal Government, or any agency of any government.

Approved & Released For UL CCS By:

Tested By:

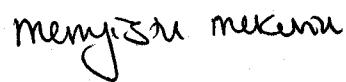

THU CHAN
ENGINEERING MANAGER
UL CCS

MENGISTU MEKURIA
EMC ENGINEER
UL CCS

2. TEST METHODOLOGY

The tests documented in this report were performed in accordance with TIA-603-C, FCC CFR 47 Part 2, FCC CFR 47 Part 22, FCC CFR Part 24, FCC Part 27, RSS-132 Issue 2, RSS-133 Issue 5 and RSS-139 Issue 2.

3. FACILITIES AND ACCREDITATION

The test sites and measurement facilities used to collect data are located at 47173 Benicia Street, Fremont, California, USA.

UL CCS is accredited by NVLAP, Laboratory Code 200065-0. The full scope of accreditation can be viewed at <http://www.ccsemc.com>.

4. CALIBRATION AND UNCERTAINTY

4.1. MEASURING INSTRUMENT CALIBRATION

The measuring equipment utilized to perform the tests documented in this report has been calibrated in accordance with the manufacturer's recommendations, and is traceable to recognized national standards.

4.2. SAMPLE CALCULATION

Where relevant, the following sample calculation is provided:

$$\text{Field Strength (dBuV/m)} = \text{Measured Voltage (dBuV)} + \text{Antenna Factor (dB/m)} + \text{Cable Loss (dB)} - \text{Preamp Gain (dB)}$$

$$36.5 \text{ dBuV} + 18.7 \text{ dB/m} + 0.6 \text{ dB} - 26.9 \text{ dB} = 28.9 \text{ dBuV/m}$$

4.3. MEASUREMENT UNCERTAINTY

Where relevant, the following measurement uncertainty levels have been estimated for tests performed on the apparatus:

PARAMETER	UNCERTAINTY
Conducted Disturbance, 0.15 to 30 MHz	3.52 dB
Radiated Disturbance, 30 to 1000 MHz	4.94 dB

Uncertainty figures are valid to a confidence level of 95%.

5. EQUIPMENT UNDER TEST

5.1. DESCRIPTION OF EUT

The EUT is Bluetooth featured Tri Band CDMA Phone that is manufactured by Kyocera Communications, Inc.

5.2. MAXIMUM OUTPUT POWER

The transmitter has a maximum ERP & EIRP output powers as follows:

824 to 849 MHz Authorized Band

Frequency Range (MHz)	Modulation	ERP Output Power (dBm)	ERP Output Power (mW)
Low CH - 824.70	CDMA2000	24.32	270.4
Mid CH - 836.52		25.77	377.6
High CH - 848.31		24.96	313.3

1850 to 1910 MHz Authorized Band

Frequency Range (MHz)	Modulation	EIRP Output Power (dBm)	EIRP Output Power (mW)
Low CH - 1851.25	CDMA2000	22.66	184.5
Mid CH - 1880.00		21.94	156.3
High CH - 1908.75		21.79	151.0

1710 to 1755 MHz Authorized Band

Frequency Range (MHz)	Modulation	EIRP Output Power (dBm)	EIRP Output Power (mW)
Low CH - 1711.25	AWS	23.52	224.9
MID-Ch- 1733.00		24.50	281.8
High CH - 1753.75		23.38	217.8

5.3. SOFTWARE AND FIRMWARE

The EUT is linked with Agilent Communication Test Set.

5.4. WORST-CASE CONFIGURATION AND MODE

The worst-position was the EUT with highest emissions. To determine the worst-case, the EUT was investigated for X, Y, and Z-Positions, and the worst position among X, Y, or Z with AC/DC adapter and headset, after the investigations, the worst-position was turned out to be Z and Y-Position without AC Adapter and headset for cell band and PCS/AWS bands respectively.

PROCEDURE USED TO ESTABLISH TEST SIGNAL

3G-CDMA2000 1xRTT

This procedure assumes the Agilent 8960 Test Set has the following applications installed and with valid license.

<u>Application</u>	<u>Rev. License</u>
CDMA2000 Mobil Test	B.10.11, L

1xRTT

- Call Setup > Shift & Preset
- Protocol Rev > 6 (IS-2000-0)
- Radio Config (RC) > RC3 (Fwd3, Rvs3)
- FCH Service Option (SO) Setup > 55
- Traffic Data Rate > Full
- TDSO SCH Info > F-SCH Parameters > F-SCH Data Rate > 153.6 kbps
> R-SCH Parameters > R-SCH Data Rate > 153.6 kbps
- Cell Info > Cell Parameters > System ID (SID) > 65535
> Network ID (NID) > 0

Once "Active Cell" show "Connected " then change "Rvs Power Ctrl" from "Active bits" to "**All Up bits**" to get the maximum power.

Worst-case Measurement Result @ Low, Middle and High Channel

Worst-case Measurement Result for Low, Middle and High Channel under Radio Configuration RC3 and Service Option 55.

5.5. DESCRIPTION OF TEST SETUP

SUPPORT EQUIPMENT

PERIPHERAL SUPPORT EQUIPMENT LIST				
Description	Manufacturer	Model	Serial Number	FCC ID
AC Adapter	Kyocera	CSP-31ADT	SSW-2001	DoC
Headset	N/A	N/A	N/A	N/A

I/O CABLES

I/O CABLE LIST						
Cable No.	Port	# of Identical Ports	Connector Type	Cable Type	Cable Length	Remarks
2	DC	1	US 115V	Un-shielded	N/A	NA
3	Mic	1	Earphone	Un-shielded	1m	NA

TEST SETUP

The EUT is a CDMA phone and-is tested as a standalone configuration. Communications Test Set is used to link the device under test.

SETUP DIAGRAM FOR TESTS

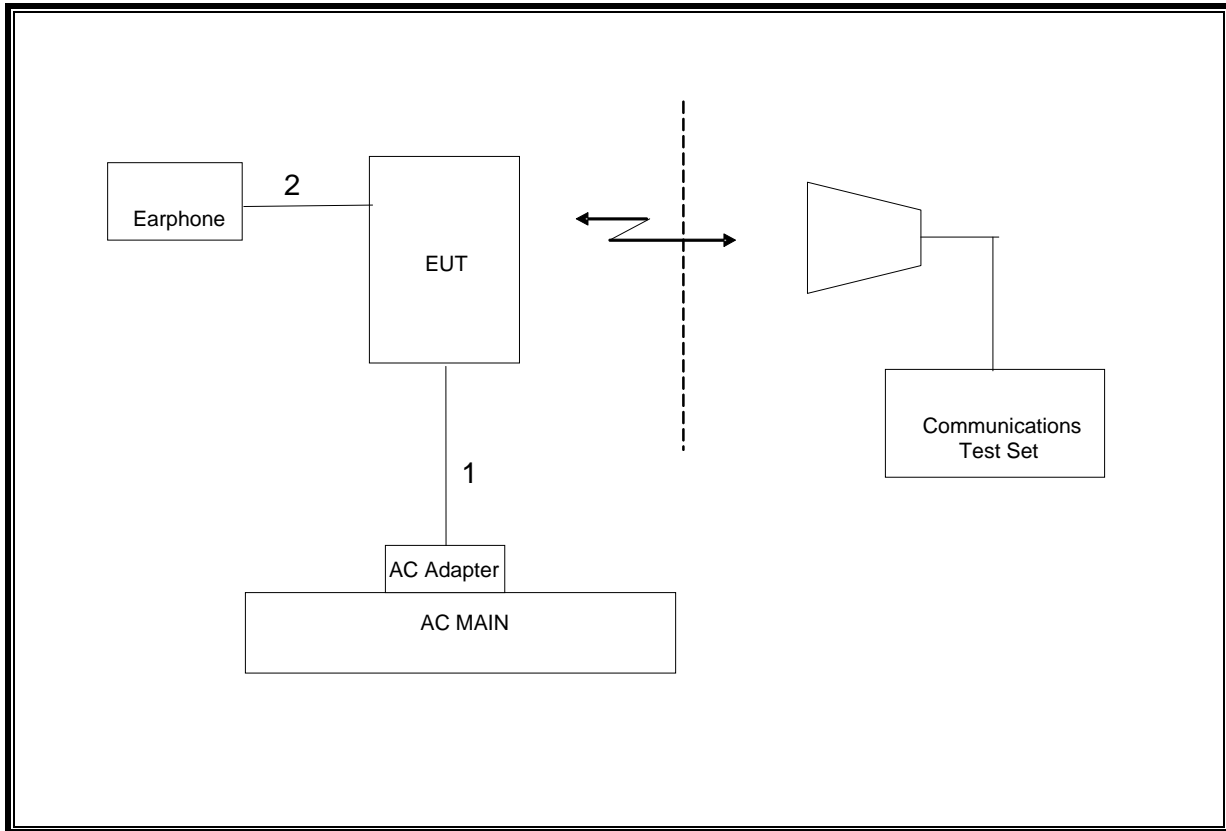

6. TEST AND MEASUREMENT EQUIPMENT

The following test and measurement equipment was utilized for the tests documented in this report:

TEST EQUIPMENT LIST				
Description	Manufacturer	Model	Asset	Cal Due
Spectrum Analyzer, 26.5 GHz	Agilent / HP	E4440A	C01178	08/15/2012
Spectrum Analyzer, 44 GHz	Agilent / HP	E4446A	C00996	05/04/12
Communications Test Set	Agilent / HP	E5515C	C01086	06/17/12
Communications Test Set	Agilent / HP	E5515C	1000732	09/27/12
Vector signal generator, 6 GHz	Agilent / HP	E4438C	None	06/09/12
EMI Test Receiver, 9 kHz-7	R & S	ESCI 7	1000741	07/06/12
Antenna, Horn, 18 GHz	EMCO	3115	C00783	06/29/12
Antenna, Horn, 18 GHz	EMCO	3115	C00943	CNR
Antenna, Horn, 18 GHz	EMCO	3115	C00945	06/29/12
Antenna, Bilog, 2 GHz	Sunol Sciences	JB1	C01011	07/16/12
Antenna, Bilog, 2 GHz	Sunol Sciences	JB1	C01016	07/16/12
Preamplifier, 1300 MHz	Agilent / HP	8447D	C00885	01/27/12
Preamplifier, 26.5 GHz	Agilent / HP	8449B	C01052	07/12/12
Preamplifier, 26.5 GHz	Agilent / HP	8449B	C01063	07/12/12
LISN, 30 MHz	FCC	LISN-50/250-25-	N02625	11/10/11
Dipole	Speag	D900V2	N/A	11/16/11
Highpass Filter, 1.5 GHz	Micro-Tronics	HPM13193	N02689	CNR
Highpass Filter, 2.7 GHz	Micro-Tronics	HPM13194	N02687	CNR

7. LIMITS AND RESULTS

7.1. RADIATED OUTPUT POWER

LIMITS

22.913(a) The ERP of mobile transmitters and auxiliary test transmitters must not exceed 7 Watts.

24.232(b) & RSS133 § 6.4 Mobile/portable stations are limited to 2 watts e.i.r.p. peak power and the equipment must employ means to limit the power to the minimum necessary for successful communications.

27.50 (d) (2) & RSS-139 § 6.4 Fixed, mobile, and portable (hand-held) stations operating in the 1710-1755 MHz band are limited to a peak EIRP of 1 watt.

RSS-132 § 4.4 The maximum ERP shall be 6.3 Watts for mobile stations.

TEST PROCEDURE

ANSI / TIA / EIA 603 Clause 2.2.17, RSS-132, RSS-133, & RSS-139.

RESULTS

CELL OUTPUT POWER (ERP)

High Frequency Substitution Measurement Compliance Certification Services Chamber B								
Company:		KYOCERA						
Project #:		11U13921						
Date:		07/21/11						
Test Engineer:		MENGISTU MEKURIA						
Configuration:		EUT ALONE						
Mode:		TX, CELL BAND CDMA MODE						
Test Equipment:								
Receiving: Sunol T130, and 3m Chamber N-type Cable (Setup this one for testing EUT)								
Substitution: Dipole S/N: 00022117, 6ft SMA Cable (SN # 208947003) Warehouse.								
f MHz	SG reading (dBm)	Ant. Pol. (H/V)	Cable Loss (dB)	Antenna Gain (dBd)	ERP (dBm)	Limit (dBm)	Margin (dB)	Notes
824.70	24.82	V	0.5	0.0	24.32	38.5	-14.1	
824.70	7.34	H	0.5	0.0	6.84	38.5	-31.6	
836.52	26.27	V	0.5	0.0	25.77	38.5	-12.7	
836.52	7.56	H	0.5	0.0	7.06	38.5	-31.4	
848.31	25.46	V	0.5	0.0	24.96	38.5	-13.5	
848.31	8.82	H	0.5	0.0	8.32	38.5	-30.1	
Rev. 3.17.11								

PCS OUTPUT POWER (EIRP)

High Frequency Fundamental Measurement Compliance Certification Services Chamber A								
Company:		KYOCERA						
Project #:		11U13921						
Date:		10/03/11						
Test Engineer:		MENGISTU MEKURIA						
Configuration:		EUT ALONE w/EARPHONE						
Mode:		TX, PCS BAND CDMA MODE						
Test Equipment:								
Receiving: Horn T72, and Camber A SMA Cables								
Substitution: Horn T60 Substitution, 4ft SMA Cable (193961002) Warehouse								
f GHz	SG reading (dBm)	Ant. Pol. (H/V)	Cable Loss (dB)	Antenna Gain (dBi)	EIRP (dBm)	Limit (dBm)	Delta (dB)	Notes
1.851	7.2	V	0.85	8.01	14.36	33.0	-18.6	
1.851	15.5	H	0.85	8.01	22.66	33.0	-10.3	
1.880	6.5	V	0.85	8.13	13.78	33.0	-19.2	
1.880	14.7	H	0.85	8.13	21.94	33.0	-11.1	
1.909	5.8	V	0.85	8.13	13.08	33.0	-19.9	
1.909	14.5	H	0.85	8.13	21.79	33.0	-11.2	
Rev. 3.17.11								

AWS OUTPUT POWER (EIRP)

High Frequency Fundamental Measurement Compliance Certification Services Chamber B								
Company:		KYOCERA						
Project #:		11U13921						
Date:		10/03/11						
Test Engineer:		MENGISTU MEKURIA						
Configuration:		EUT ALONE						
Mode:		TX, AWS BAND CDMA MODE						
Test Equipment:								
Receiving: Horn T59, and Camber B SMA Cables								
Substitution: Horn T73 Substitution, 6ft SMA Cable (208947003) Warehouse								
f GHz	SG reading (dBm)	Ant. Pol. (H/V)	Cable Loss (dB)	Antenna Gain (dBi)	EIRP (dBm)	Limit (dBm)	Delta (dB)	Notes
1.711	15.6	V	0.85	8.01	22.78	33.0	-10.2	
1.711	16.4	H	0.85	8.01	23.52	33.0	-9.5	
1.733	16.1	V	0.85	8.07	23.32	33.0	-9.7	
1.733	17.3	H	0.85	8.07	24.50	33.0	-8.5	
1.754	14.1	V	0.85	8.13	21.42	33.0	-11.6	
1.754	16.1	H	0.85	8.13	23.38	33.0	-9.6	
Rev. 1.24.7								

7.2. FIELD STRENGTH OF SPURIOUS RADIATION

LIMIT

§22.917 (e) and §24.238 (a), RSS-132 § 4.5.1, & RSS-133 § 6.5.1 (a) (i) & (b): Out of band emissions. The power of any emission outside of the authorized operating frequency ranges must be attenuated below the transmitting power (P) by a factor of at least $43 + 10 \log (P)$ dB.

§27.53 (g) and RSS-139 § 6.5 For operations in the 1710–1755MHz and 2110–2155 MHz bands, the power of any emission outside a licensee's frequency block shall be attenuated below the transmitter power (P) by at least $43 + 10 \log_{10} (P)$ dB.

TEST PROCEDURE

ANSI / TIA / EIA 603 Clause 3.2.12 & FCC 22.917 (b), FCC 24.238 (b), & FCC 27.53 (g)(1)(2)(3), RSS-132, RSS-133, & RSS-139.

RESULTS

CELL SPURIOUS & HARMONIC (ERP)

Compliance Certification Services Above 1GHz High Frequency Substitution Measurement									
Company:		KYOCERA							
Project #:		11U13921							
Date:		07/21/11							
Test Engineer:		MENGISTU MEKURIA							
Configuration:		EUT ALONE							
Mode:		TX, CELL BAND CDMA MODE							
Chamber		Pre-amplifer			Filter		Limit		
5m Chamber B		T145 8449B			Filter 1		FCC Part 22		
f GHz	SG reading (dBm)	Ant. Pol. (H/V)	Distance (m)	Preamp (dB)	Filter (dB)	ERP (dBm)	Limit (dBm)	Delta (dB)	Notes
Low Channel (824.7MHz)									
1.649	14.3	V	3.0	35.5	1.0	-20.2	-13.0	-7.2	
2.474	-5.7	V	3.0	35.4	1.0	-40.1	-13.0	-27.1	
3.299	-10.9	V	3.0	35.5	1.0	-45.5	-13.0	-32.5	
1.649	11.9	H	3.0	35.5	1.0	-22.6	-13.0	-9.6	
2.474	-3.8	H	3.0	35.4	1.0	-38.3	-13.0	-25.3	
3.299	-10.0	H	3.0	35.5	1.0	-44.5	-13.0	-31.5	
Mid Channel (836.52MHz)									
1.673	15.2	V	3.0	35.5	1.0	-19.3	-13.0	-6.3	
2.510	-3.2	V	3.0	35.4	1.0	-37.7	-13.0	-24.7	
3.346	-7.1	V	3.0	35.5	1.0	-41.6	-13.0	-28.6	
5.856	-13.2	V	3.0	35.5	1.0	-47.7	-13.0	-34.7	
1.673	9.8	H	3.0	35.5	1.0	-24.8	-13.0	-11.8	
2.510	-3.0	H	3.0	35.4	1.0	-37.4	-13.0	-24.4	
3.346	-5.8	H	3.0	35.5	1.0	-40.3	-13.0	-27.3	
High Channel (848.31MHz)									
1.697	10.1	V	3.0	35.5	1.0	-24.4	-13.0	-11.4	
2.545	-14.2	V	3.0	35.4	1.0	-48.6	-13.0	-35.6	
3.393	-7.9	V	3.0	35.5	1.0	-42.4	-13.0	-29.4	
1.697	6.1	H	3.0	35.5	1.0	-28.4	-13.0	-15.4	
2.545	-6.0	H	3.0	35.4	1.0	-40.4	-13.0	-27.4	
3.393	-6.7	H	3.0	35.5	1.0	-41.2	-13.0	-28.2	
Rev. 03.03.09									
Note: No other emissions were detected above the system noise floor.									

PCS Spurious & Harmonic (EIRP)

Compliance Certification Services									
Above 1GHz High Frequency Substitution Measurement									
Company:		KYOCERA							
Project #:		11U13921							
Date:		07/21/11							
Test Engineer:		MENGISTU MEKURIA							
Configuration:		EUT ALONE							
Mode:		TX, PCS BAND CDMA MODE							
Chamber		Pre-amplifier			Filter		Limit		
3m Chamber		T34 8449B			Filter 1		Part 24		
f GHz	SG reading (dBm)	Ant. Pol. (H/V)	Distance (m)	Preamp (dB)	Filter (dB)	EIRP (dBm)	Limit (dBm)	Delta (dB)	Notes
Low Ch, 1851.25MHz									
3.702	1.4	V	3.0	35.4	1.0	-33.0	-13.0	-20.0	
5.554	-17.5	V	3.0	34.7	1.0	-51.3	-13.0	-38.3	
3.702	-3.5	H	3.0	35.4	1.0	-37.9	-13.0	-24.9	
5.554	-12.1	H	3.0	34.7	1.0	-45.8	-13.0	-32.8	
Mid Ch, 1880MHz									
3.760	10.5	V	3.0	35.3	1.0	-23.8	-13.0	-10.8	
5.640	-18.1	V	3.0	34.7	1.0	-51.8	-13.0	-38.8	
3.760	3.4	H	3.0	35.3	1.0	-30.9	-13.0	-17.9	
5.640	-11.9	H	3.0	34.7	1.0	-45.6	-13.0	-32.6	
High Ch, 1908.75MHz									
3.818	13.8	V	3.0	35.3	1.0	-20.5	-13.0	-7.5	
5.726	-17.4	V	3.0	34.7	1.0	-51.1	-13.0	-38.1	
3.818	7.5	H	3.0	35.3	1.0	-26.7	-13.0	-13.7	
5.726	-11.2	H	3.0	34.7	1.0	-45.0	-13.0	-32.0	
Rev. 03.03.09									
Note: No other emissions were detected above the system noise floor.									

AWS Spurious & Harmonic (EIRP)

Compliance Certification Services Above 1GHz High Frequency Substitution Measurement									
Company:		KYOCERA							
Project #:		11U13921							
Date:		08/07/11							
Test Engineer:		MENGISTU MEKURIA							
Configuration:		EUT ALONE							
Mode:		TX, AWS BAND CDMA MODE							
Chamber		Pre-amplifier			Filter		Limit		
5m Chamber B		T145 8449B			Filter 1		Part 27		
f GHz	SG reading (dBm)	Ant. Pol. (H/V)	Distance (m)	Preamp (dB)	Filter (dB)	EIRP (dBm)	Limit (dBm)	Delta (dB)	Notes
Low Ch, 1711.25MHz									
3.423	-12.2	V	3.0	35.5	1.0	-46.7	-13.0	-33.7	
5.134	-19.9	V	3.0	35.3	1.0	-54.2	-13.0	-41.2	
3.423	-18.1	H	3.0	35.5	1.0	-52.5	-13.0	-39.5	
5.134	-20.0	H	3.0	35.3	1.0	-54.4	-13.0	-41.4	
Mid Ch, 1732.5MHz									
3.465	-14.9	V	3.0	35.5	1.0	-49.3	-13.0	-36.3	
5.198	-20.6	V	3.0	35.3	1.0	-54.9	-13.0	-41.9	
3.465	-18.9	H	3.0	35.5	1.0	-53.4	-13.0	-40.4	
5.198	-20.5	H	3.0	35.3	1.0	-54.8	-13.0	-41.8	
High Ch, 1753.75MHz									
3.508	-13.8	V	3.0	35.4	1.0	-48.2	-13.0	-35.2	
5.261	-19.7	V	3.0	35.3	1.0	-54.1	-13.0	-41.1	
3.508	-18.2	H	3.0	35.4	1.0	-52.7	-13.0	-39.7	
5.261	58.0	H	3.0	35.3	1.0	23.6	-13.0	36.6	
Rev. 03.03.09									
Note: No other emissions were detected above the system noise floor.									

7.1. RECEIVER SPURIOUS EMISSIONS

LIMIT

RSS-Gen 7.2.2

Spurious Emission Limits for Receivers:

Spurious Frequency (MHz)	Field Strength (microvolts/m at 3 metres)
30-88	100
88-216	150
216-960	200
Above 960	500

TEST PROCEDURE

The search for spurious emissions shall be from the lowest frequency internally generated or used in the receiver (local oscillator frequency, intermediate frequency or carrier frequency), or 30 MHz, whichever is the higher, to at least 3 times the highest tunable and local oscillator frequencies.

RESULTS

SPURIOUS EMISSIONS 30 TO 1000 MHz (WORST-CASE CONFIGURATION, HORIZONTAL)

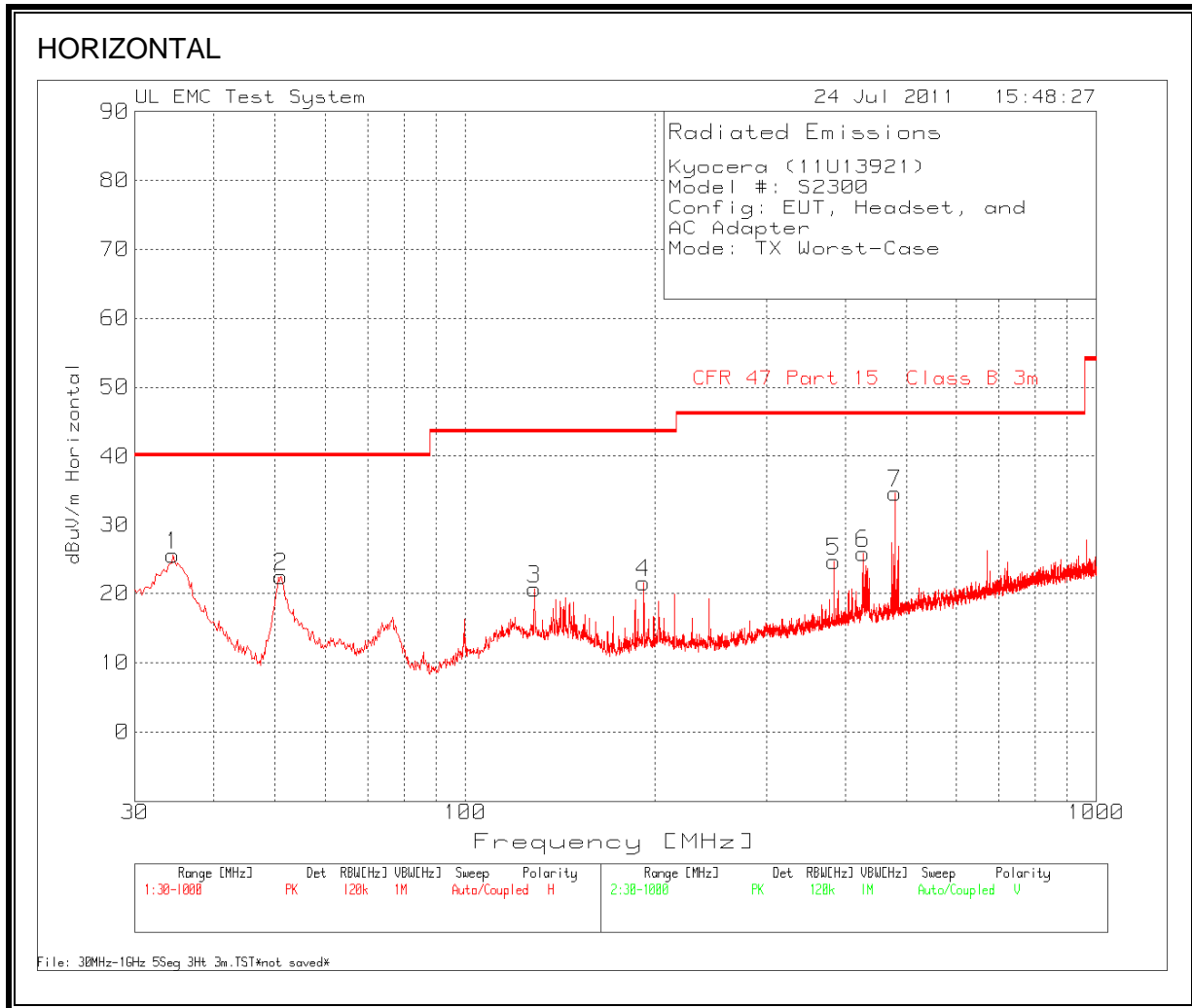

SPURIOUS EMISSIONS 30 TO 1000 MHz (WORST-CASE CONFIGURATION, VERTICAL)

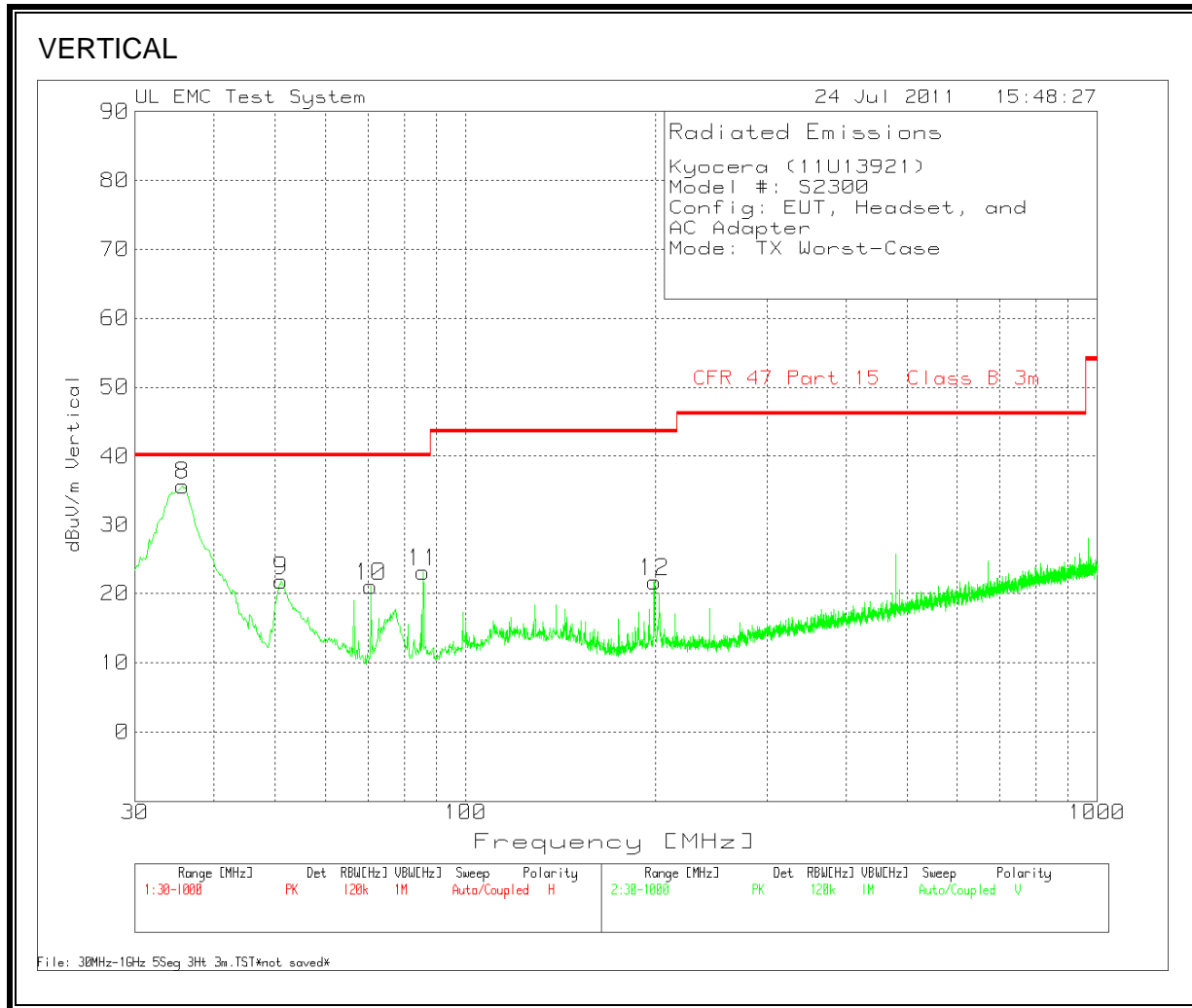

SPURIOUS EMISSIONS 30 TO 1000 MHz (WORST-CASE CONFIGURATION)

HORIZONTAL AND VERTICAL DATA											
Kyocera (11U13921)											
Model #: S2300											
Config: EUT, Headset, and											
AC Adapter											
Mode: TX Worst-Case											
Range 1 30 - 1000MHz											
Test	Meter	Detector	5m A	5m A T64	5m A T122]	dBuV/m	CFR 47 Part 15	Margin	Height [cm]	Polarity	
Frequency	Reading		Cable [dB]	PreAmp [dB]	Bilog [dB]		Class B 3m				
34.4584	34.99	PK	0.6	-28.3	18.2	25.49	40	-14.51	300	Horz	
51.1291	41.67	PK	0.8	-28.3	8.3	22.47	40	-17.53	300	Horz	
128.8609	34.08	PK	1.2	-28.2	13.6	20.68	43.5	-22.82	200	Horz	
191.8605	36.69	PK	1.5	-28.1	11.5	21.59	43.5	-21.91	100	Horz	
383.9608	35.68	PK	2.2	-27.9	14.7	24.68	46	-21.32	100	Horz	
427.3821	35.9	PK	2.3	-27.8	15.4	25.8	46	-20.2	100	Horz	
480.1079	43.59	PK	2.4	-27.7	16.4	34.69	46	-11.31	200	Horz	
Range 2 30 - 1000MHz											
Test	Meter	Detector	5m A	5m A T64	5m A T122]	dBuV/m	CFR 47 Part 15	Margin	Height [cm]	Polarity	
Frequency	Reading		Cable [dB]	PreAmp [dB]	Bilog [dB]		Class B 3m				
35.6215	46.04	PK	0.6	-28.3	17.4	35.74	40	-4.26	100	Vert	
51.1291	41.06	PK	0.8	-28.3	8.3	21.86	40	-18.14	300	Vert	
70.9013	40.34	PK	0.9	-28.2	8	21.04	40	-18.96	100	Vert	
85.6335	42.83	PK	1	-28.2	7.4	23.03	40	-16.97	100	Vert	
199.0328	36.4	PK	1.5	-28.1	11.9	21.7	43.5	-21.8	100	Vert	

SPURIOUS EMISSIONS ABOVE 1000 MHz (WORST-CASE CONFIGURATION)

Note: No emissions above the noise floor were observed.

7.2. POWER LINE CONDUCTED EMISSION

LIMIT

RSS-Gen 7.2.2

Except when the requirements applicable to a given device state otherwise, for any licence-exempt radio communication device equipped to operate from the public utility AC power supply, either directly or indirectly, the radio frequency voltage that is conducted back onto the AC power lines in the frequency range of 0.15 MHz to 30 MHz shall not exceed the limits shown in Table 2. The tighter limit applies at the frequency range boundaries.

Table 2 – AC Power Lines Conducted Emission Limits

Frequency of Emission (MHz)	Conducted Limit (dBuV)	
	Quasi-peak	Average
0.15-0.5	66 to 56 [*]	56 to 46 [*]
0.5-5	56	46
5-30	60	50

^{*} Decreases with the logarithm of the frequency.

RESULTS

6 WORST EMISSIONS

Kyocera (11U13921)									
Model #: S2300									
Config: EUT, Headset, and									
AC Adapter									
Tx Worst-Case									
Line-L1 .15 - 30MHz									
Test	Meter	Detector	LISN [dB]	Conducted	dB[uVolts]	CISPR 11/22 Class B	Margin	CISPR 11/22 Class B	Margin
Frequency	Reading			Cable [dB]		Quasi-peak		Average	
0.1995	60.25	PK	0	0	60.25	63.6	-3.35	53.6	6.65
0.1995	42.84	Av	0	0	42.84	-	-	53.6	-10.76
0.2715	54.94	PK	0	0	54.94	61.1	-6.16	51.1	3.84
0.2715	34.02	Av	0	0	34.02	-	-	51.1	-17.08
0.3345	51.52	PK	0	0	51.52	59.3	-7.78	49.3	2.22
0.3345	37.57	Av	0	0	37.57	-	-	49.3	-11.73
Line-L2 .15 - 30MHz									
Test	Meter	Detector	LISN [dB]	Conducted	dB[uVolts]	CISPR 11/22 Class B	Margin	CISPR 11/22 Class B	Margin
Frequency	Reading			Cable [dB]		Quasi-peak		Average	
0.1995	55.6	PK	0	0	55.6	63.6	-8	53.6	2
0.1995	36.55	Av	0	0	36.55	-	-	53.6	-17.05
0.2625	49.7	PK	0	0	49.7	61.4	-11.7	51.4	-1.7
0.2625	31.39	Av	0	0	31.39	-	-	51.4	-20.01
0.42	48.21	PK	0	0	48.21	57.4	-9.19	47.4	0.81
0.42	27.1	Av	0	0	27.1	-	-	47.4	-20.3

LINE 1 RESULTS

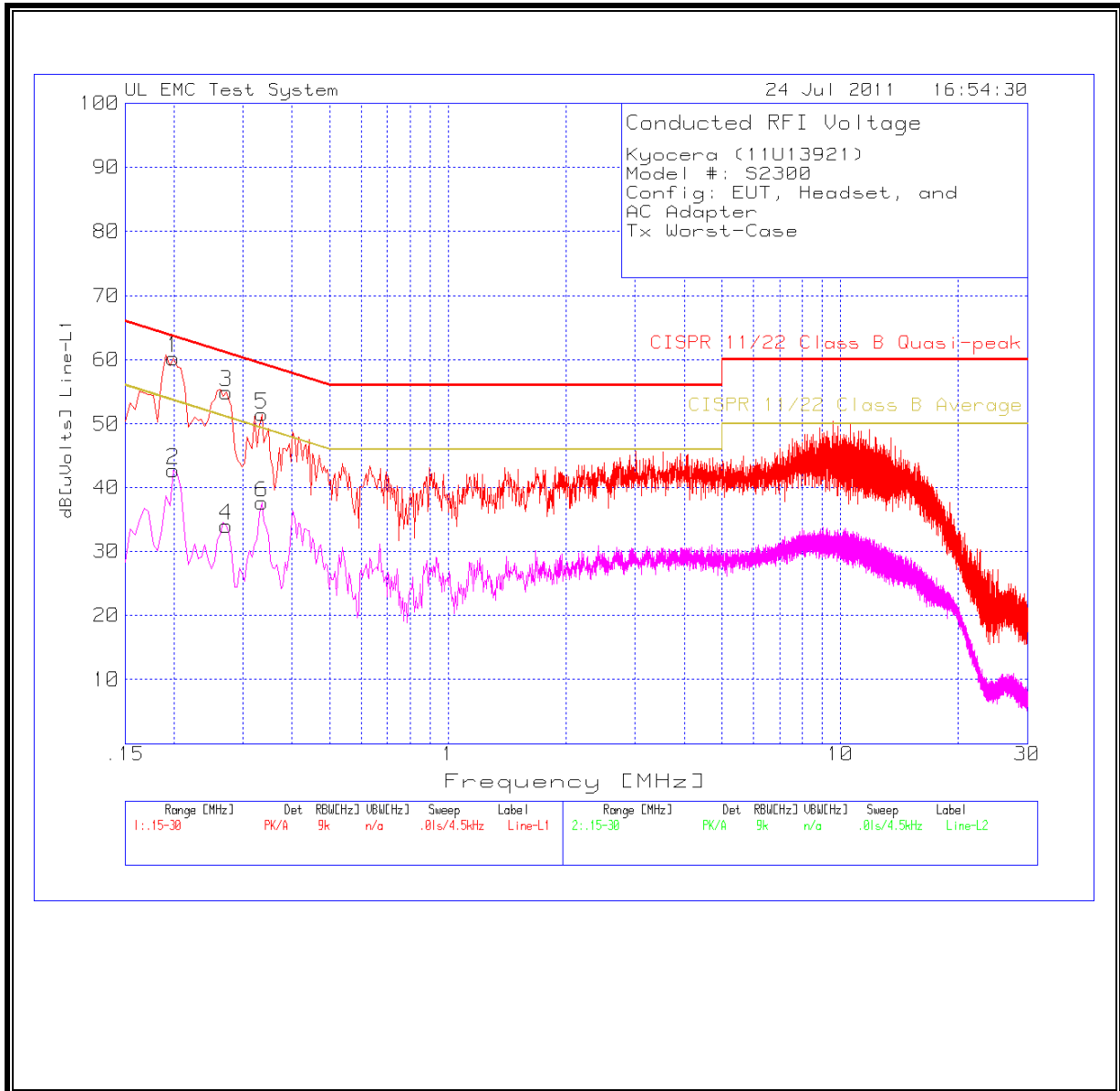

LINE 2 RESULTS

