

Applicant:	Kyocera
FCC ID:	OVF-K33BIC04
Report #:	CT-S1310-24-0612-R0

RF Emissions Test Report

FCC Part 24

For

Kyocera Corporation
c/o Kyocera Communication Inc.

Product:	CDMA Phone
Model:	S1310

TABLE OF CONTENTS

1	SUMMARY OF TESTING	4
2	EQUIPMENT UNDER TEST INFORMATION.....	4
3	TEST FACILITIES.....	5
4	TEST SETUP	5
4.1	Test Configuration	6
5	Conducted RF OUTPUT POWER	6
6	Conducted RF OUTPUT POWER	7
6.1	Test Configuration	7
6.2	Test Results.....	7
7	RADIATED RF OUTPUT POWER	8
7.1	Test Configuration	8
8	PEAK-AVERAGE RATIO	9
8.1	Test Configuration	9
8.2	Test Result	9
9	OCCUPIED BANDWIDTH.....	11
9.1	Test Configuration	11
9.2	Test Result	11
10	Spurious Emissions At Antenna Terminals.....	14
10.1	Test Configuration	14
10.2	Test Result	14
11	Transmitter Radiated Spurious Emissions.....	19
11.1	Test Configuration and Result.....	19
12	Receiver Spurious Emissions.....	19
12.1	Receiver Spurious Emissions	19
13	Transmitter RF Carrier Frequency Stability	19
13.1	Test Configuration	20
13.2	Test Result	20
14	Exposure of Humans to RF Fields (SAR)	22
14.1	Test Configuration and Result.....	22
15	TEST EQUIPMENT.....	22

Applicant:	Kyocera
FCC ID:	OVF-K33BIC04
Report #:	CT-S1310-24-0612-R0

ATTESTATION

The tested device complies with the requirements in respect of all parameters subject to the test.

The test results and statements relate only to the items tested.

The test equipment used was suitable for the tests performed and within manufacturer's published specifications and operating parameters.

The test methods were consistent with the methods described in the relevant standards.

Product:	CDMA Cellular Phone
Model #:	S1310
FCC ID:	OVF-K33BIC04
Tested in accordance with:	FCC Part 24
Test performed by:	CompTest Services LLC
Test Requested by:	Kyocera Corporation c/o Kyocera Communication Inc 8611 Balboa Avenue San Diego, CA 92121 United States
Date of Test:	June 18 - 20, 2012

Responsible Engineer

Benjamin Nguyen

Benjamin Nguyen
Test Engineer

Reviewed and approved by:



Tammy To
Quality Manager

1 SUMMARY OF TESTING

Section #	Rule Part	Test Description	Verdict
6	FCC § 2.1046	Conducted Power	Pass
7	FCC § 22.913, 24.232	Radiated Power	Pass
8	FCC § 24.232(d)	Peak-to-Average Ratio	Pass
9	FCC § 2.1049, 22.917 (b)(d), 24.238	Occupied Bandwidth	Pass
10	FCC § 2.1051, 22.917(e)(f), 24.238	Spurious Emissions at Antenna Terminals	Pass
11	FCC § 2.1053, 22.91, 24.238	Transmitter Radiated Spurious Emissions	Pass
12	FCC § 15.109	Receiver Spurious Emissions	Pass
13	FCC § 2.1055, 22.355, 24.235	Transmitter RF Carrier Frequency Stability	Pass
14	FCC § 2.1093	Exposure of Humans to RF Fields	Pass

2 EQUIPMENT UNDER TEST INFORMATION

EUT Serial Number:	268435459907099541
Type:	<input type="checkbox"/> Prototype, <input checked="" type="checkbox"/> Pre-Production, <input type="checkbox"/> Production
Equipment Category:	Portable
RF Exposure Environment:	General Population / Uncontrolled
Antenna:	Internal Antenna
Detachable Antenna:	No
External Input:	Audio/Digital Data
Quantity:	Quantity production is planned
Multiple Access Scheme:	CDMA
Emission Designators:	1M25F9W
FCC Rule Parts:	§24E
Modes:	1900 CDMA
TX Frequency (MHz):	1850 - 1910
Conducted Output Power (W):	23.0

3 TEST FACILITIES

The test sites and measurement facilities used to collect data are located at 8611 Balboa Avenue, San Diego, CA 92123, USA

4 TEST SETUP

All CDMA measurements were conducted with a base station simulator to establish a CDMA link with the equipment under test (EUT). To investigate the response of the EUT the main antenna RF output port of the EUT was connected to the input of the spectrum analyzer with a RF cable. The amplitude of the spectrum analyzer is corrected for the cable insertion loss and any other applicable losses. A fully charged battery was used as a power supply voltage, except for the Transmitter RF Carrier Frequency Stability test a dummy battery connected to a power supply was used.

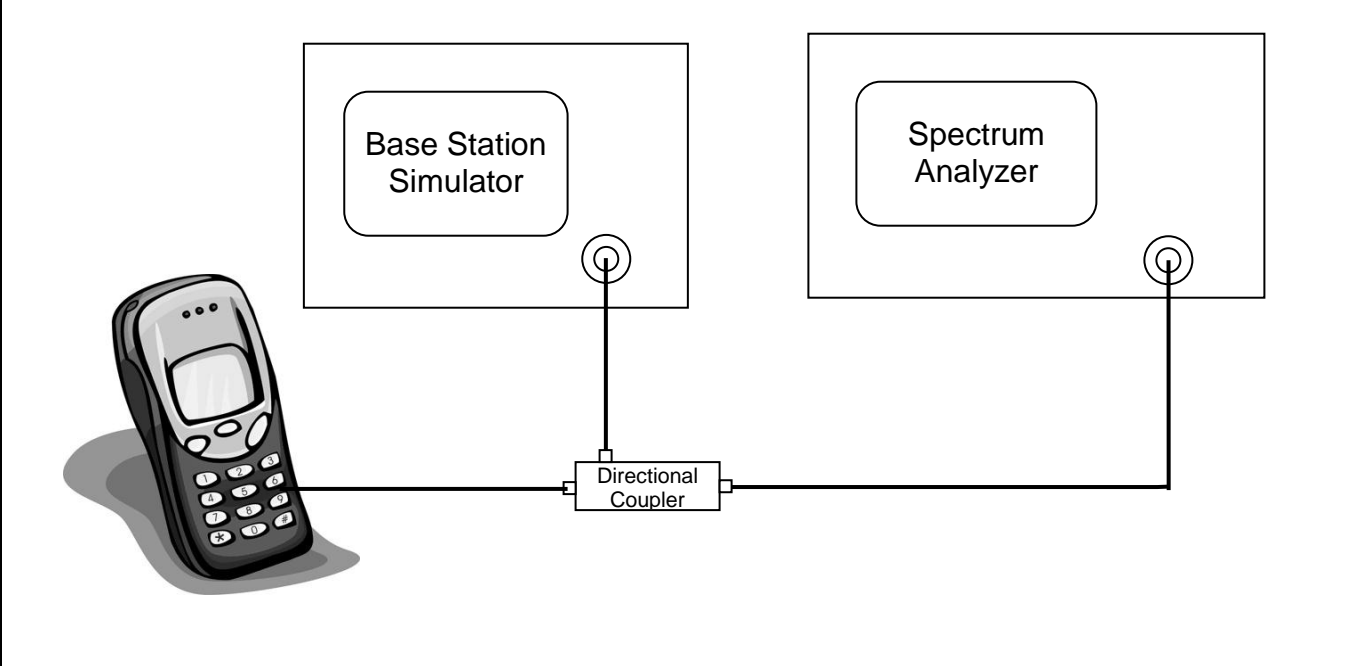

4.1 Test Configuration

To justify on the selection of applicable configurations, the EUT was pre-tested under all Radio Configuration and Service Option operation modes to determine the worst-case scenario.

The following configuration was determined and reported as worst-case for all measurements:

Radio Configuration:	RC1
Service Options:	SO55
Data Rate:	Full Rate

CONFIGURATION Peak Power	CONDUCTED POWER (dBm)		
	CDMA 1900		
	Ch 25	Ch 600	Ch 1175
	Peak	Peak	Peak
SO2, RC1 Full Rate	27.92	28.46	28.36
SO2, RC3 Full Rate	27.59	28.30	27.80
SO55, RC1 Full Rate	28.71	28.62	28.37
SO55, RC3 Full Rate	27.87	28.29	28.32
TDSO SO32, RC3 (F+SCH)	27.60	28.15	27.63
TDSO SO32, RC3 (SCH)	27.57	28.24	27.99

CONFIGURATION Average Power	CONDUCTED POWER (dBm)		
	CDMA 1900		
	Ch 25	Ch 600	Ch 1175
	Avg	Avg	Avg
SO2, RC1 Full Rate	23.00	23.34	23.16
SO2, RC3 Full Rate	23.04	23.31	23.07
SO55, RC1 Full Rate	23.03	23.36	23.12
SO55, RC3 Full Rate	23.05	23.37	23.17
TDSO SO32, RC3 (F+SCH)	23.02	23.34	23.08
TDSO SO32, RC3 (SCH)	23.04	23.36	23.12

5 TTY COMPLIANCE

Applicant:	Kyocera
FCC ID:	OVF-K33BIC04
Report #:	CT-S1310-24-0612-R0

FCC: § 255 of the Telecom Act

The EUT has been designed for TTY Compliance with Cellular Compatibility Standard.

6 CONDUCTED RF OUTPUT POWER

6.1 Test Configuration

FCC: § 2.1046

IC: RSS132 §4.4; RSS133 §6.4

The EUT was connected to a Universal Power Meter through a RF cable. The cable loss was taken into account for accurate power measurement. The EUT was set at low, mid, high channels and each frequency band to investigate the conducted power.

6.2 Test Results

Mode	Frequency (MHz)	Channel	Conducted Power (dBm)
CDMA 1900	1851.25	25	23.05
	1880	600	23.37
	1908.75	1175	23.17

Applicant:	Kyocera
FCC ID:	OVF-K33BIC04
Report #:	CT-S1310-24-0612-R0

7 RADIATED RF OUTPUT POWER

7.1 Test Configuration

FCC: § 22.913, § 24.232

IC: RSS132 §4.4; RSS133 §6.4

The test was performed in Compliance Certification Service using substitution method. See separated radiated emission report for details.

8 PEAK-AVERAGE RATIO

8.1 Test Configuration

FCC: § 24.232(d)

IC: RSS133 (6.4)

The RF output of the EUT was connected to the input of the spectrum analyzer (S.A.) with sufficient attenuation. The spectrum analyzer Complementary Cumulative Distribution Function (CCDF) function is utilized to determine the largest deviation between average and peak power of the EUT.

For Digital: Modulate with full rate and all up power control bit.

S.A. Setting	RBW	VBW
Power Stat CCDF	5MHz	auto

Limits: <13 dB

8.2 Test Result

Figure	Description	Mode	Result
8-1	CCDF @ Ch600	CDMA 1900	Pass

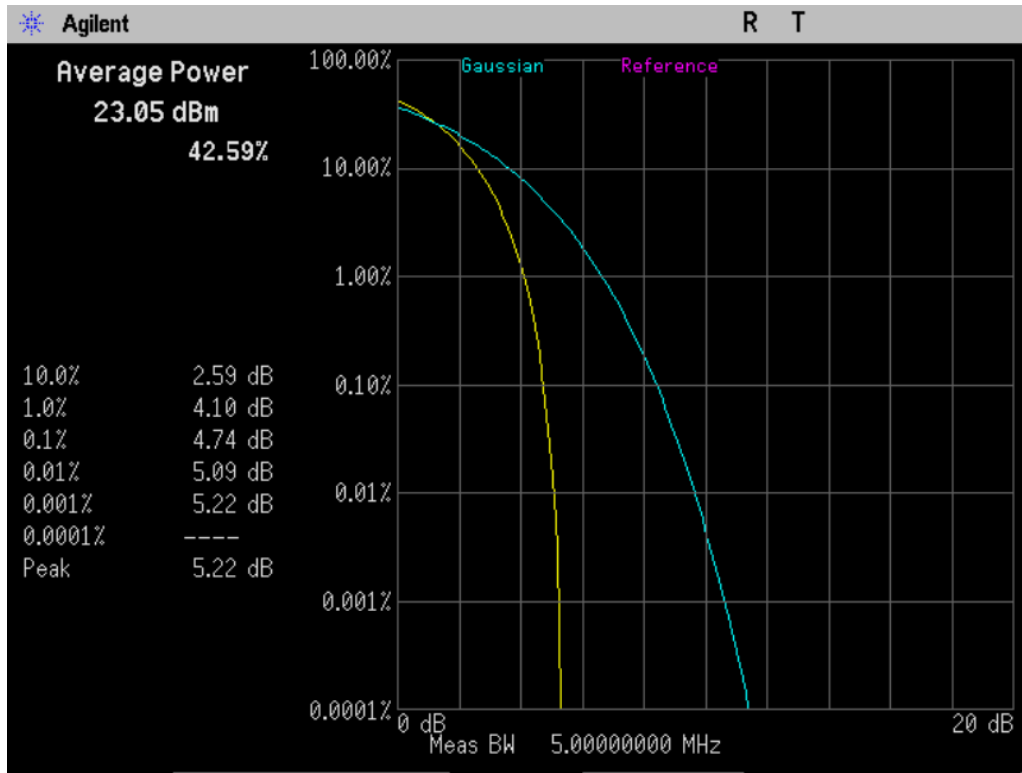

Figure 8-1 CCDF @ CH 600

9 OCCUPIED BANDWIDTH

9.1 Test Configuration

FCC:	§ 2.1049, § 22.917(b)(d), § 24.238, § 27.53(g)(1)	
IC:	RSS132 §4.5; RSS133 §6.5	
<p>The RF output of the EUT was connected to the input of the spectrum analyzer (S.A.) with sufficient attenuation. The spectrum with no modulation was recorded.</p> <p>For Digital: Modulate with full rate all up power control bit.</p>		
S.A. Setting	RBW	VBW
Bandwidth Measurement	30KHz	300kHz
Band Edge Measurement	30KHz	100KHz
<p>Limits: Bandwidth: N/A Bandedge: -13dBm</p>		

9.2 Test Result

Figure	Description	Mode	Result
9-1	CDMA @ CH600	CDMA 1900	Pass
9-2	Lower Band Edge @ CH 25		Pass
9-3	Upper Band Edge @ CH 1175		Pass

Applicant:	Kyocera
FCC ID:	OVF-K33BIC04
Report #:	CT-S1310-24-0612-R0

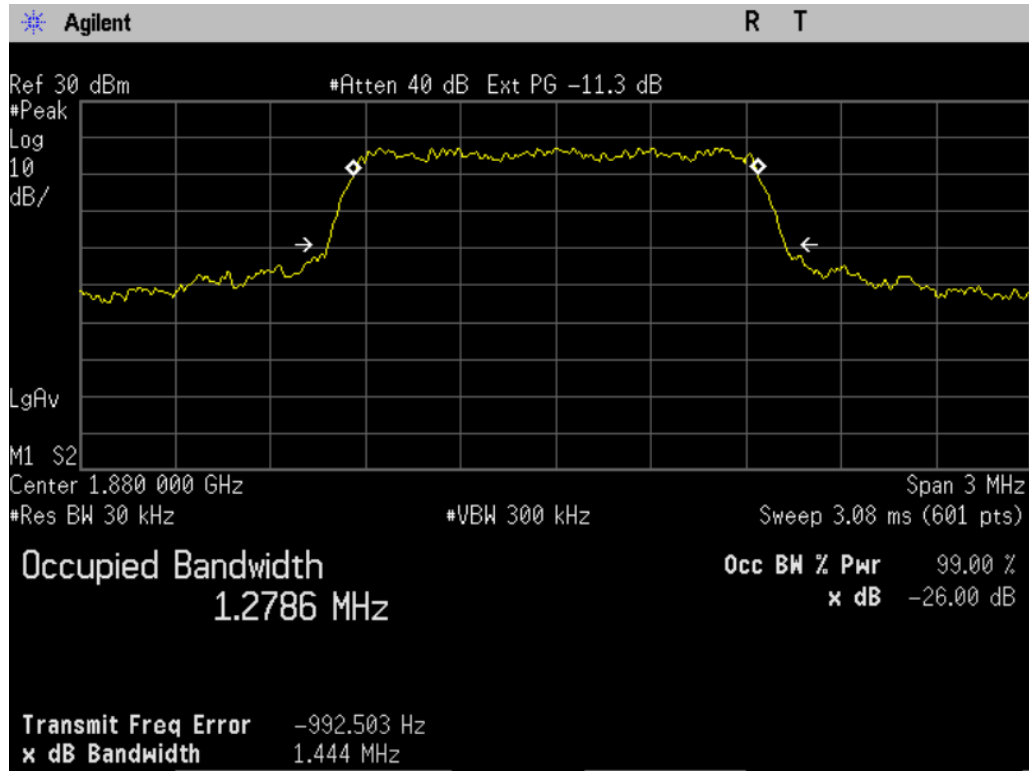

Figure 9-1 CDMA 1900 @ CH 600

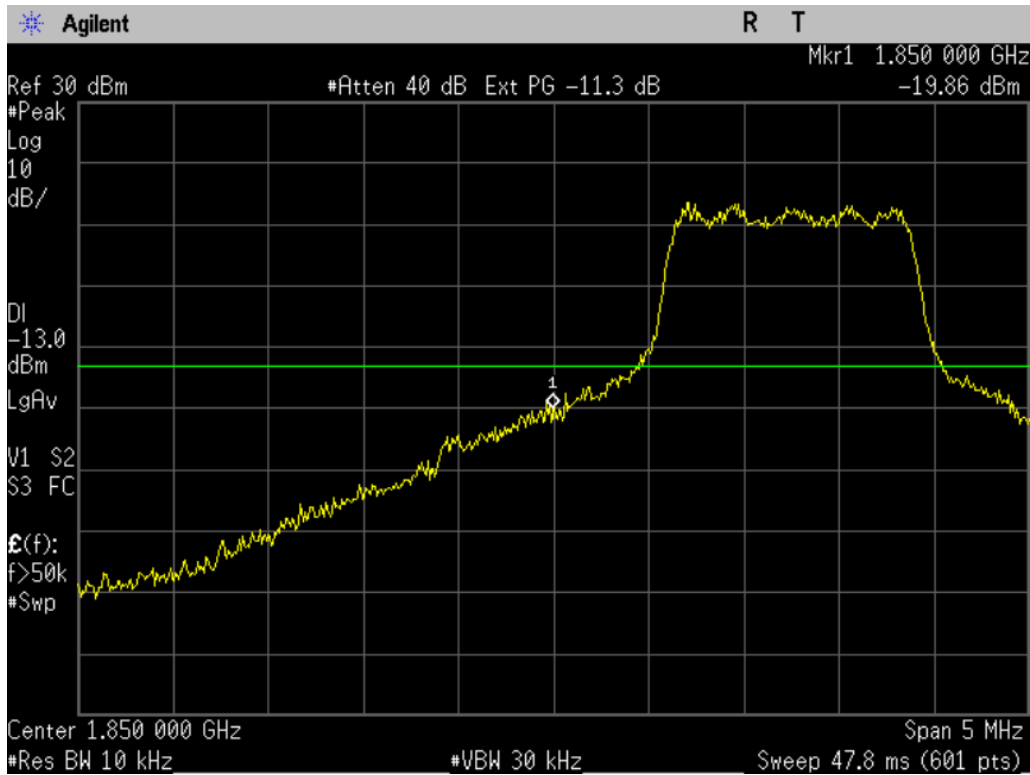

Figure 9-2 CDMA 1900 Lower Band Edge @ CH 25

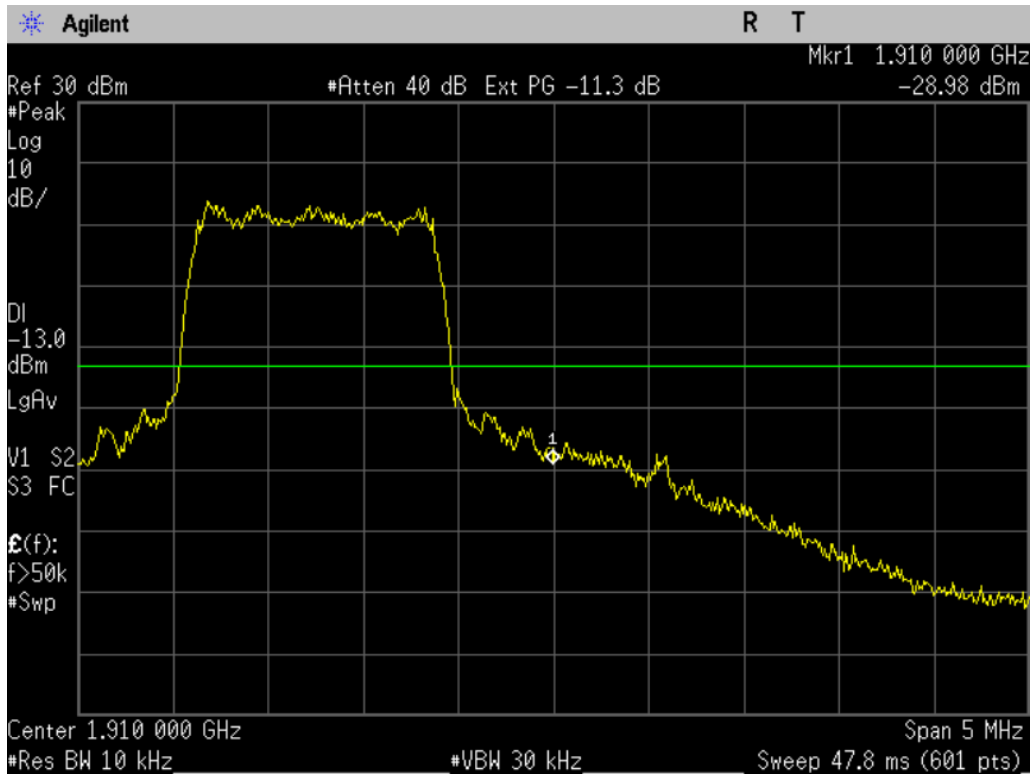

Figure 9-3 CDMA 1900 Upper Band Edge @ CH 1175

10 SPURIOUS EMISSIONS AT ANTENNA TERMINALS

10.1 Test Configuration

FCC: § 2.1051, § 22.917(e)(f), § 24.238

IC: RSS132 §4.5; RSS133 §6.5

Measurement Procedures:

Out of Band: The RF output of the EUT was connected to the input of the spectrum analyzer with sufficient attenuation. The modulating signal was applied accordingly. The frequency spectrum was investigated from the lowest frequency signal generated up to at least the tenth harmonic of the fundamental.

S.A. Setting	RBW	VBW
Spurious Emissions Measurement	1MHz	1MHz

Limits: -13dBm

10.2 Test Result

Figure	Channel	Plot Description	Result
10-1	25	CDMA 1900 Conducted spurious emissions 9kHz to 20GHz	Pass
10-2	600		Pass
10-3	1175		Pass

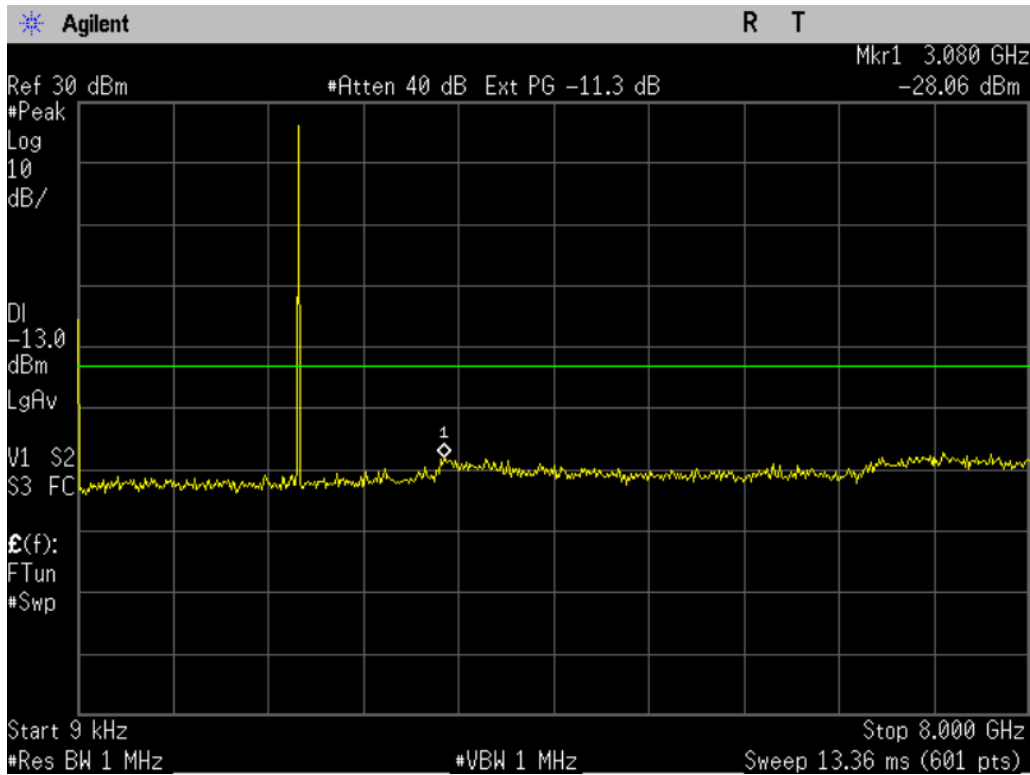

Figure 10-1a CDMA 1900 - Conducted Spurious Emission (CH 25)

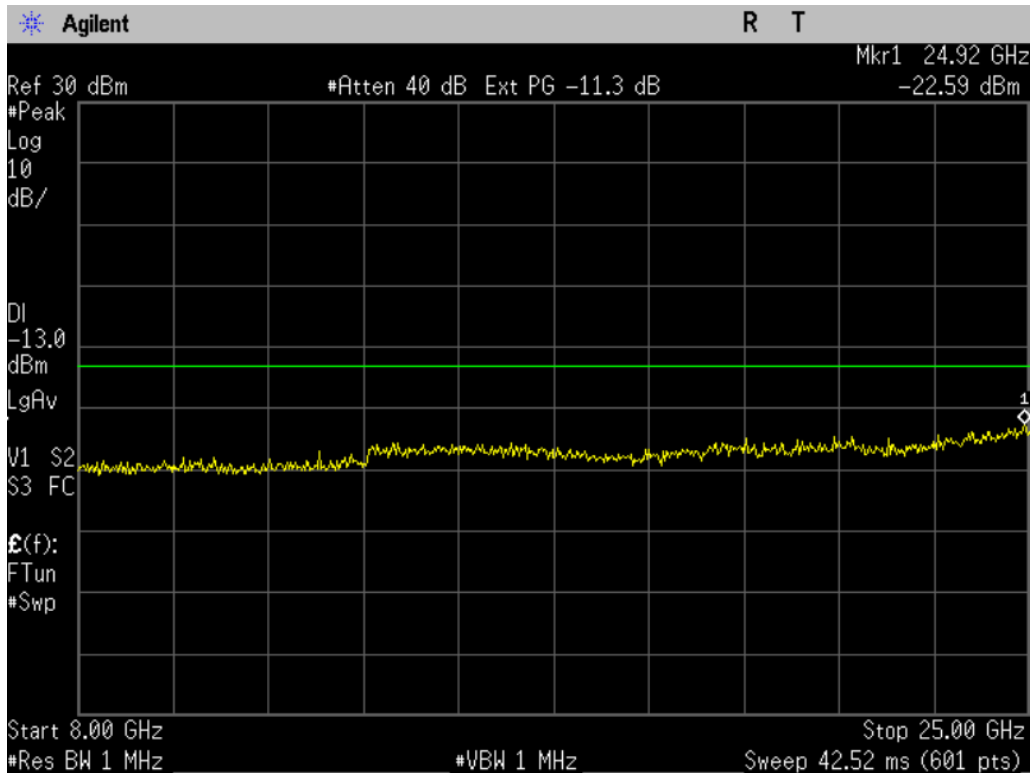

Figure 10-1b CDMA 1900 - Conducted Spurious Emission (CH 25)

Applicant:	Kyocera
FCC ID:	OVF-K33BIC04
Report #:	CT-S1310-24-0612-R0

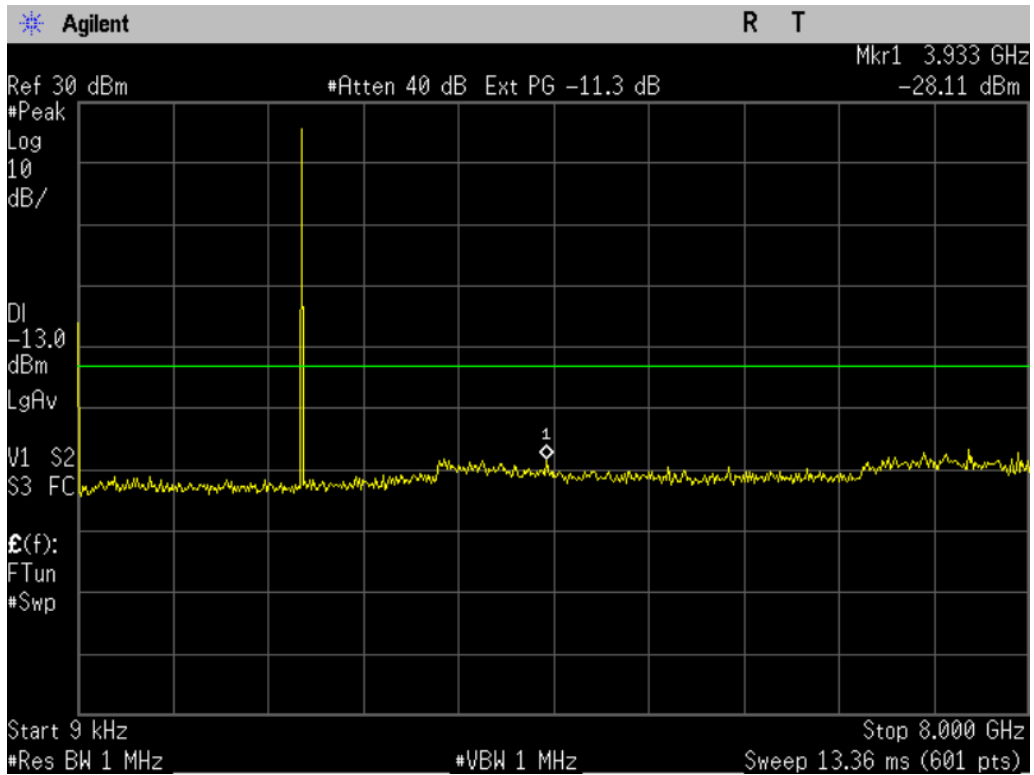

Figure 10-2a CDMA 1900 - Conducted Spurious Emission (CH 600)

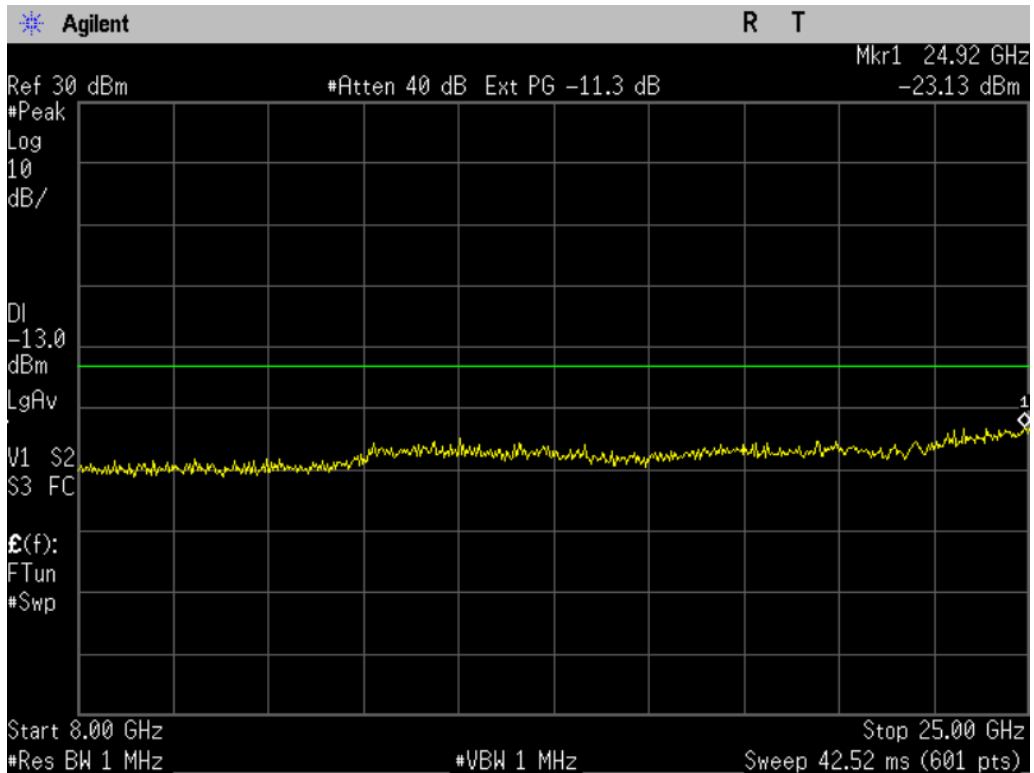

Figure 10-2b CDMA 1900 - Conducted Spurious Emission (CH 600)

Applicant:	Kyocera
FCC ID:	OVF-K33BIC04
Report #:	CT-S1310-24-0612-R0

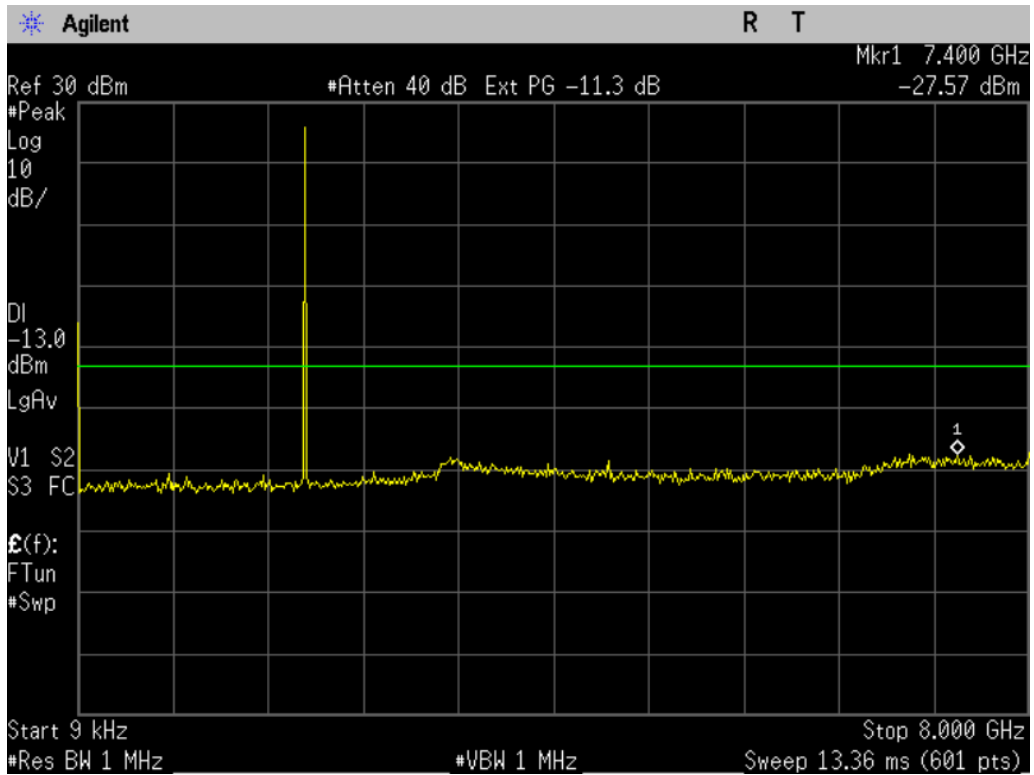

Figure 10-3a CDMA 1900 - Conducted Spurious Emission (CH 1175)

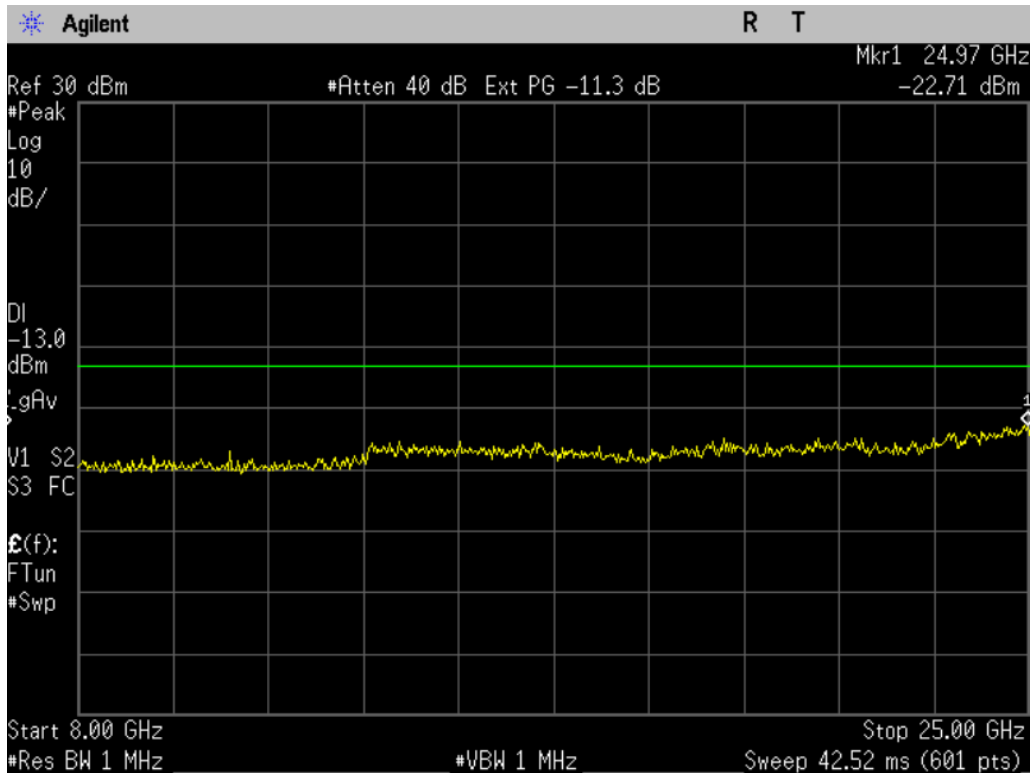

Figure 10-3b CDMA 1900 - Conducted Spurious Emission (CH 1175)

Applicant:	Kyocera
FCC ID:	OVF-K33BIC04
Report #:	CT-S1310-24-0612-R0

Applicant:	Kyocera
FCC ID:	OVF-K33BIC04
Report #:	CT-S1310-24-0612-R0

11 TRANSMITTER RADIATED SPURIOUS EMISSIONS

11.1 Test Configuration and Result

FCC: § 2.1053, § 22.91, § 24.238, §27.53(g)
IC: RSS132 §4.5; RSS133 §6.5
The radiated spurious emission test was performed at Compliance Certification Service. The test report is attached in a separate attachment.

12 RECEIVER SPURIOUS EMISSIONS

12.1 Receiver Spurious Emissions

FCC: § 15.109
IC: RSS-GEN
The receiver radiated spurious emission test was performed at Compliance Certification Service. The test report is attached in a separate attachment.

13 TRANSMITTER RF CARRIER FREQUENCY STABILITY

Applicant:	Kyocera
FCC ID:	OVF-K33BIC04
Report #:	CT-S1310-24-0612-R0

13.1 Test Configuration

FCC: § 2.1055, § 22.355, § 24.235, § 27.54

IC: RSS132 §4.3; RSS133 §6.3

The EUT was placed in an environmental chamber. The RF output of the EUT was connected to Agilent 8960 Series 10 E5515C. A power supplier was connected as primary voltage supply. Only the mid channel of each frequency band was investigated.

Limits:

Tx Frequency	Channel	Limit
1880 MHz	600	+/- 2.5 ppm (+/-4700 Hz)

13.2 Test Result

CDMA 1900						
Temperature (°C)	Deviation of Carrier (Hz)			Specification (Hz)		Result
	3.3V (Battery endpoint)	3.7V	4.2V (115%)	Lower limit	Upper limit	
-30		12.87		-4700	4700	Pass
-20		-9.30		-4700	4700	
-10		11.00		-4700	4700	
0		-8.40		-4700	4700	
10		12.53		-4700	4700	
20	-5.61	5.34	8.19	-4700	4700	
30		-7.65		-4700	4700	
40		12.19		-4700	4700	
50		-5.84		-4700	4700	
60		6.78		-4700	4700	

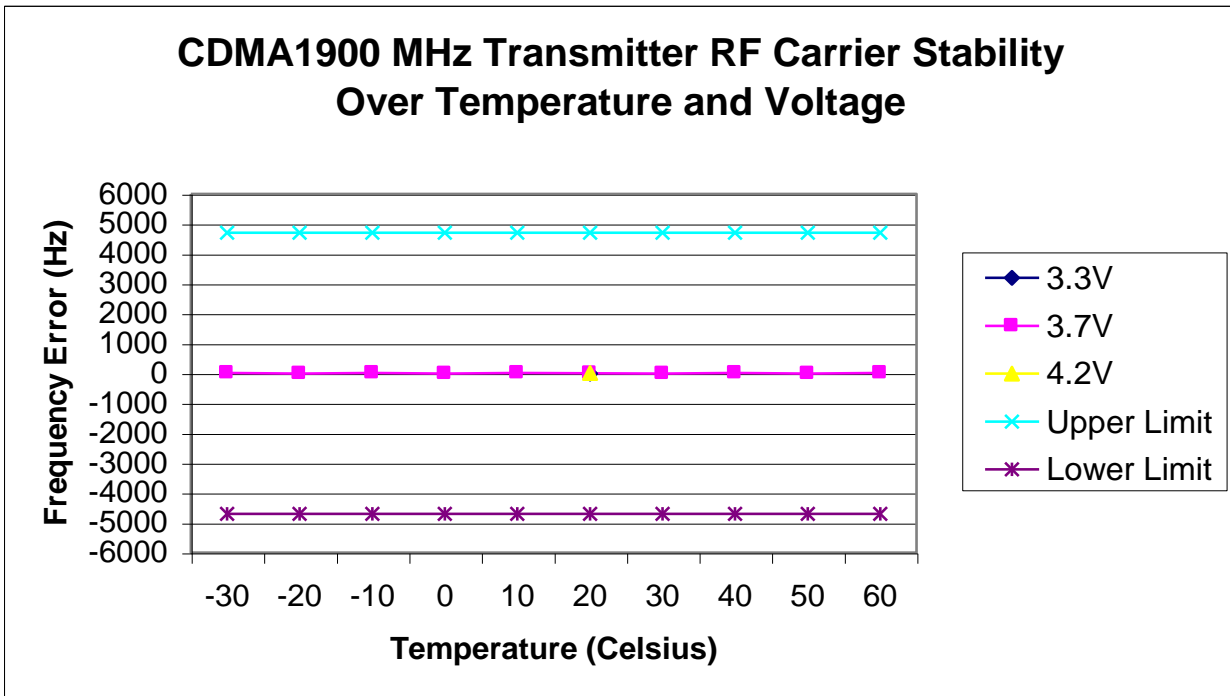

Applicant:	Kyocera
FCC ID:	OVF-K33BIC04
Report #:	CT-S1310-24-0612-R0

14 EXPOSURE OF HUMANS TO RF FIELDS (SAR)

14.1 Test Configuration and Result

FCC: § 2.1093
IC: RSS102
The SAR test report is attached in a separate attachment.

15 TEST EQUIPMENT

The test equipment utilized to perform the tests documented in this report has been calibrated in accordance with the manufacturer's recommendations and is traceable to recognized national standards.

Description	Manufacturer	Model No.	Serial No.	Cal Due Date
Power Meter	Giga-tronics	8541C	1831306	09/08/12
Spectrum Analyzer	Agilent	E4440A	MY44303130	12/14/12
Wireless Communications Test Set	Agilent	8960	GB44052789	12/02/13
Temperature Chamber	Test Equity	ZH2-033-033-H/AC	ZZ9622421	06/24/12