



RADIO REPORT FCC 47 CFR Part 15C ISED Canada RSS-247 Digital transmission systems operating within the 902 – 928 MHz band	
Report Reference No	G0M-1701-6190-TFC247DT-V01
Testing Laboratory	Eurofins Product Service GmbH
Address	Storkower Str. 38c 15526 Reichenwalde Germany
Accreditation	  <p>A2LA Accredited Testing Laboratory, Certificate No.: 1983.01 FCC Filed Test Laboratory, Reg.-No.: 96970 ISED OATS Filing assigned code: 3470A</p>
Applicant	Kamstrup A/S
Address	Industrivej 28 8660 Skanderborg DENMARK
Test Specification	According to FCC/IC rules
Standard	47 CFR Part 15C RSS-247, Issue 1, 2015-05 ANSI C63.10:2013
Non-Standard Test Method	None
Test scope	complete Radio compliance test
Equipment under Test (EUT):	
Product Description	READY Converter for US/Canada market
Model(s)	READY Converter
Additional Model(s)	None
Brand Name(s)	READY Converter
Hardware Version(s)	55501455-D3
Software Version(s)	50981365-B1 / 55141586-B1
	FCC-ID: OUY-READYAMR3 IC: 22376-READYAMR3
Test Result	PASSED

Possible test case verdicts:		
required by standard but not tested	N/T	
not required by standard	N/R	
test object does meet the requirement	P(PASS)	
test object does not meet the requirement	F(FAIL)	
Testing:		
Test Lab Temperature	20 - 23 °C	
Test Lab Humidity	32 – 38 %	
Date of receipt of test item	2017-02-13	
Date (s) of performance of tests	2017-02-14 – 2017-02-15	
Report:		
Compiled by	Sebastian Suckow	
Tested by (+ signature) (Responsible for Test)	Sebastian Suckow	
Approved by (+ signature) (Head of Lab)	Christian Weber	
Date of Issue	2017-03-08	
Total number of pages	96	
General Remarks:		
<p>The test results presented in this report relate only to the object tested.</p> <p>The results contained in this report reflect the results for this particular model and serial number. It is the responsibility of the manufacturer to ensure that all production models meet the intent of the requirements detailed within this report.</p> <p>This report shall not be reproduced, except in full, without the written approval of the Issuing testing laboratory.</p>		
Additional Comments:		

VERSION HISTORY

Version History			
Version	Issue Date	Remarks	Revised By
01	2017-03-08	Initial Release	

ABBREVIATIONS AND ACRONYMS

Acronyms	
Acronym	Description
EUT	Equipment Under Test
FCC	Federal Communications Commission
ISED	Innovation, Science and Economic Development Canada
RBW	Resolution bandwidth
RMS	Root mean square
VBW	Video bandwidth
V _{NOM}	Nominal supply voltage

REPORT INDEX

1	Equipment (Test Item) Under Test.....	6
1.1	Photos – Equipment External.....	7
1.2	Photos – Equipment Internal.....	11
1.3	Photos – Test Setup.....	13
1.4	Support Equipment.....	15
1.5	Test mode duty cycle.....	16
1.6	Test Modes.....	17
1.7	Test Frequencies.....	18
1.8	Sample emission level calculation.....	19
2	Result Summary.....	20
3	Test Conditions and Results.....	21
3.1	Test Conditions and Results - Occupied bandwidth.....	21
3.2	Test Conditions and Results - 6 dB bandwidth.....	24
3.3	Test Conditions and Results - Maximum peak conducted output power.....	27
3.4	Test Conditions and Results - Power spectral density.....	28
3.5	Test Conditions and Results - AC powerline conducted emissions.....	31
3.6	Test Conditions and Results - Band-edge compliance.....	34
3.7	Test Conditions and Results - Conducted spurious emissions.....	37
3.8	Test Conditions and Results - Transmitter radiated emissions.....	40
3.9	Test Conditions and Results - Receiver radiated emissions.....	43
ANNEX A	Transmitter sprurious emissions.....	45
ANNEX B	Receiver sprurious emissions.....	81

1 Equipment (Test Item) Under Test

Description	READY Converter for US/Canada market	
Model	READY Converter	
Additional Model(s)	None	
Brand Name(s)	READY Converter	
Serial Number(s)	None	
Hardware Version(s)	55501455-D3	
Software Version(s)	50981365-B1 / 55141586-B1	
Equipment type	End Product	
Radio type	Transceiver	
Assigned frequency band	912.5 – 918.5 MHz	
Radio technology	Digital Modulation	
Modulation	2-FSK	
Number of antenna ports	1	
Antenna 1	Type	External
	Model	Whip antenna RP SMA
	Manufacturer	Laird Technology / Nearson
	Gain	2.5 dBi
Antenna 2	Type	External
	Model	Roof top antenna
	Manufacturer	Smarteq
	Gain	5.15
Supply Voltage	V _{NOM}	5.0 VDC
Operating Temperature	T _{NOM}	25 °C
Manufacturer	Kamstrup A/S Industrivej 28 8660 Skanderborg DENMARK	

1.4 Support Equipment

Product Type	Device	Manufacturer	Model	Comment
None				
Description:				
AE	Auxillary Equipment			
SIM	Simulator			
CBL	Connecting Cable			
Comment:				

1.5 Test mode duty cycle

1.5.1 Information

Test Information	
Measurement Method	ANSI C63.10 11.6

1.5.2 Requirements

Requirements	
Duty cycle	Duty cycle correction
≥ 98 %	No correction required
< 98 %	Correction required ($10 \times \text{Log}_{10}(1/\text{DC})$)

1.5.3 Setup

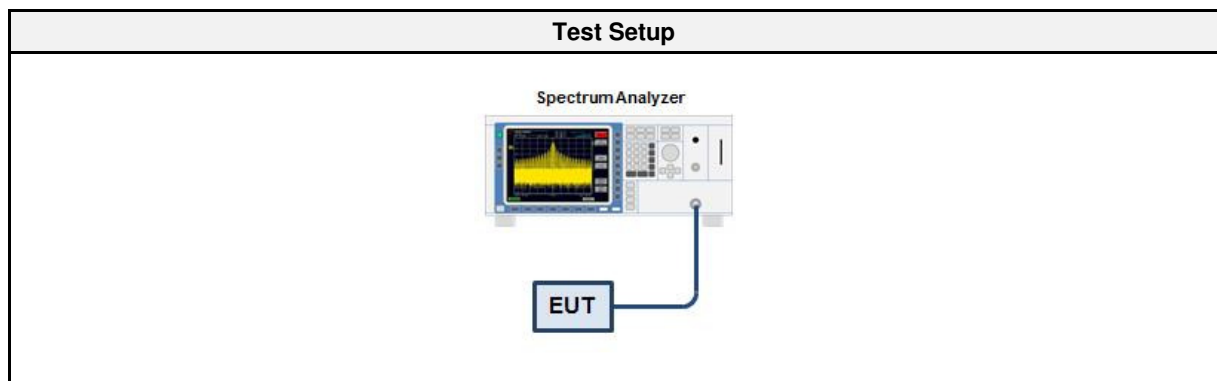

1.5.4 Equipment

Test Equipment					
Description	Manufacturer	Model	Identifier	Cal. Date	Cal. Due
Spectrum Analyzer	R&S	FSU 26	EF01003	2016-03	2017-03

1.5.5 Procedure

Test Procedure
<ol style="list-style-type: none"> 1. EUT set to test mode 2. Span is set to zero span 3. Detector set to peak 4. Sweep time is set long enough to capture at least 5 bursts 5. Envelope peak value of emission spectrum is selected 6. The maximum burst duration T_{ON} is measured using two markers set to the start and the end of the longest burst 7. The minimum idle duration T_{OFF} is measured using two markers set to the start and the end of the shortest idle period 8. The duty cycle is calculated by $DC = T_{ON} / (T_{ON} + T_{OFF})$ 9. The duty cycle correction is calculated by $DC = 10 \times \text{Log}_{10}(T_{ON} / (T_{ON} + T_{OFF}))$

1.5.6 Results

Duty Cycle Results		
Mode	Duty Cycle	Correction Factor [dB]
Transmit-PS	100%	N/R

1.6 Test Modes

Mode	Description	
Transmit-PS	General Conditions:	EUT powered by laboratory power supply
	Radio Conditions:	Mode = Transmit Modulation = 2-FSK Duty cycle = 100 % Power level = Maximum (Power setting 63)
Transmit-Bat	General Conditions:	EUT powered by fully charged battery
	Radio Conditions:	Mode = Transmit Modulation = 2-FSK Duty cycle = 100 % Power level = Maximum (Power setting 63)
Receive-PS	General Conditions:	EUT powered by laboratory power supply
	Radio Conditions:	Mode = Receive Modulation = 2-FSK
Receive-Bat	General Conditions:	EUT powered by fully charged battery
	Radio Conditions:	Mode = Receive Modulation = 2-FSK
Comment:		

1.7 Test Frequencies

Designator	Mode	Channel	Frequency [MHz]
F1	Tx / Rx	1	912.5
F2	Tx / Rx	2	915
F3	Tx / Rx	3	918.5

1.8 Sample emission level calculation

The following is a description of terms and a sample calculation, as appears in the radiated emissions data table. The numbers used in the calculation are for example only. There is no direct correlation to the specific data taken for the product described in this document:

Reading:

This is the reading obtained on the spectrum analyzer in dBμV. Any external preamplifiers used are taken into account through internal analyzer settings.

A.F.:

This is the antenna factor for the receiving antenna. It is a conversion factor, which converts electric fields strengths to voltages, which can be measured directly on the spectrum analyzer. It is treated as a loss in dB. Cable losses have been included with the A.F. to simplify the calculations. The antenna factor is used in calculations as follows:

$$\text{Reading on Analyzer (dB}\mu\text{V)} + \text{A.F. (dB)} = \text{Net field strength (dB}\mu\text{V/m)}$$

Net:

This is the net field strength measurement (as shown above).

Limit:

This is the FCC Class B radiated emission limit (in units of dBμV/m). The FCC limits are given in units of μV/m. The following formula is used to convert the units of μV/m to dBμV/m:

$$\text{Limit (dB}\mu\text{V/m)} = 20 \cdot \log(\mu\text{V/m})$$

Margin:

This is the margin of compliance below the FCC limit. The units are given in dB. A negative margin indicates the emission was below the limit. A positive margin indicates that the emission exceeds the limit.

Example only:

Reading + AF	= Net Reading	:	Net reading	- FCC limit	= Margin
+21.5 dBμV	+ 26 dB = 47.5 dBμV/m	:	47.5 dBμV/m	- 57.0 dBμV/m	= -9.5 dB

2 Result Summary

FCC 47 CFR Part 15C, ISED RSS-210				
Product Standard Reference	Requirement	Reference Method	Result	Remarks
RSS-Gen 6.6	Occupied Bandwidth	ANSI C63.10	N/R	Informational only
FCC § 15.247(a)(2) ISED RSS-247 § 5.2	6 dB Bandwidth	ANSI C63.10	PASS	
FCC § 15.247(b)(3) ISED RSS-247 § 5.4	Maximum peak conducted power	ANSI C63.10	PASS	
FCC § 15.247(e) ISED RSS-247 § 5.2	Power spectral density	ANSI C63.10	PASS	
FCC § 15.207 ISED RSS-247 § 3.1	AC power line conducted emissions	ANSI C63.10	PASS	
FCC § 15.247(d) ISED RSS-247 § 5.5	Band edge compliance	ANSI C63.10	PASS	
FCC § 15.247(d) ISED RSS-247 § 5.5	Conducted spurious emissions	ANSI C63.10	PASS	
FCC § 15.247(d) FCC § 15.209 ISED RSS-247 § 5.5	Transmitter radiated spurious emissions	ANSI C63.10	PASS	
ISED RSS-247 § 3.1	Receiver radiated spurious emissions	ANSI C63.10	PASS	
Comment:				

Possible Test Case Verdicts	
PASS	Test object does meet the requirements
FAIL	Test object does not meet the requirements
N/T	Required by standard but not tested
N/R	Not required by standard for the test object

3 Test Conditions and Results

3.1 Test Conditions and Results - Occupied bandwidth

3.1.1 Information

Test Information	
Reference	ISED RSS-Gen 6.6
Measurement Method	ANSI C63.10 6.9.3

3.1.2 Limits

Limits
None (Informational only)

3.1.3 Setup

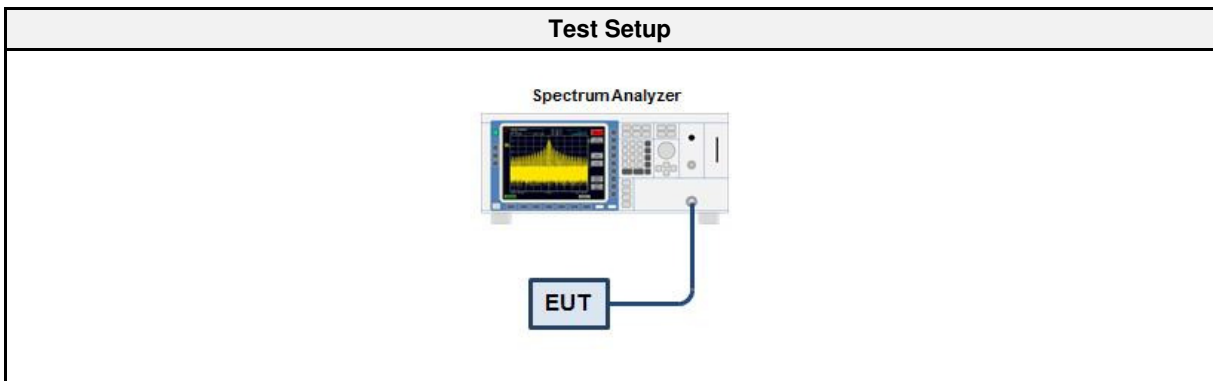

3.1.4 Equipment

Test Equipment					
Description	Manufacturer	Model	Identifier	Cal. Date	Cal. Due
Spectrum Analyzer	R&S	FSU 26	EF01003	2016-03	2017-03

3.1.5 Procedure

Test Procedure
<ol style="list-style-type: none"> 1. EUT transmitter is activated in test mode under normal conditions 2. The spectrum analyzer is set to peak detection and maximum hold with a span twice the emission spectrum 3. The resolution bandwidth is set to 1 % of the bandwidth 4. The occupied bandwidth is measured with the build-in analyzer function

3.1.6 Results

Test Results		
Mode	Frequency [MHz]	Bandwidth [MHz]
Transmit-PS	912.5	0.782
Transmit-PS	918.5	0.794

Occupied bandwidth – 912.5 MHz

Occupied Bandwidth

Project Number: G0M-1701-6190
 Applicant: Kamstrup A/S
 Model Description: READy Converter for US/Canada market
 Model: READy Converter
 Test Sample ID: 12039
 Reference Standards: FCC 15.247, RSS-247
 Reference Method: ANSI C63.10:2013, Section 6.9.3
 Operational Mode: 2-FSK, Channel: 912.5 MHz
 Operating Conditions: Tnom/Vnom
 Operator: W. Treffke
 Test Site: Eurofins Product Service GmbH
 Test Date: 2017-02-15
 Occupied Bandwidth [MHz]: 0.782

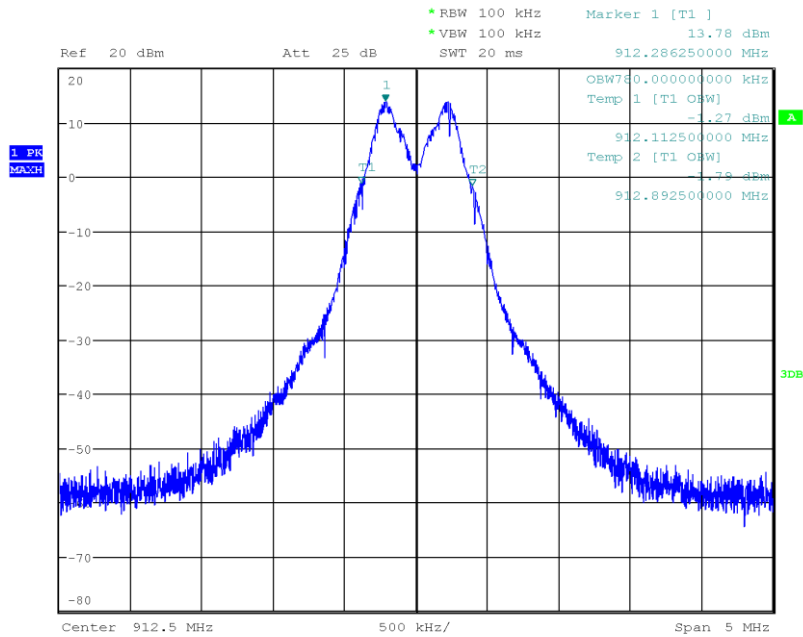

Date: 15.FEB.2017 08:50:48

Occupied bandwidth – 918.5 MHz

Occupied Bandwidth

Project Number: G0M-1701-6190
 Applicant: Kamstrup A/S
 Model Description: READy Converter for US/Canada market
 Model: READy Converter
 Test Sample ID: 12039
 Reference Standards: FCC 15.247, RSS-247
 Reference Method: ANSI C63.10:2013, Section 6.9.3
 Operational Mode: 2-FSK, Channel: 918.5 MHz
 Operating Conditions: Tnom/Vnom
 Operator: W. Treffke
 Test Site: Eurofins Product Service GmbH
 Test Date: 2017-02-15
 Occupied Bandwidth [MHz]: 0.794

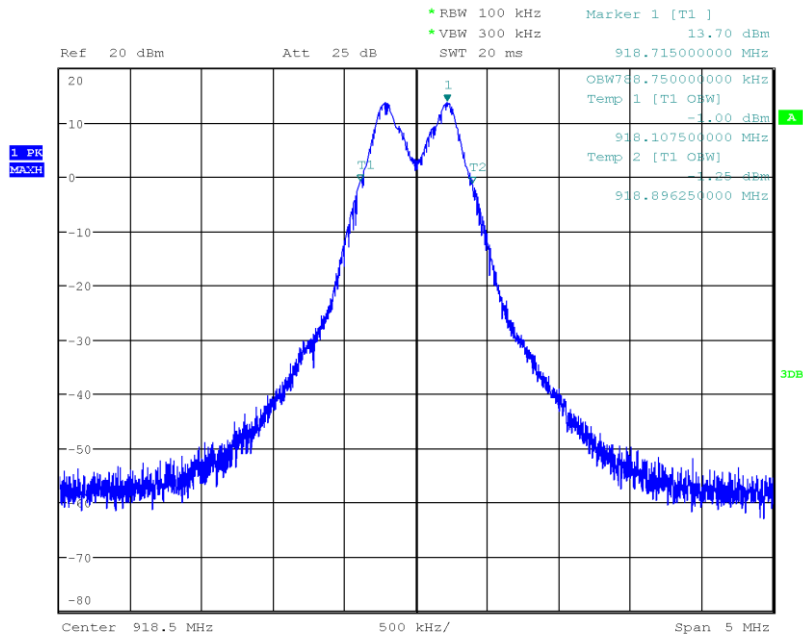

Date: 15.FEB.2017 11:46:30

3.2 Test Conditions and Results - 6 dB bandwidth

3.2.1 Information

Test Information	
Reference	FCC 15.247(a)(2) / ISED RSS-247 5.2
Measurement Method	ANSI C63.10 11.8

3.2.2 Limits

Limits
≥ 500kHz

3.2.3 Setup

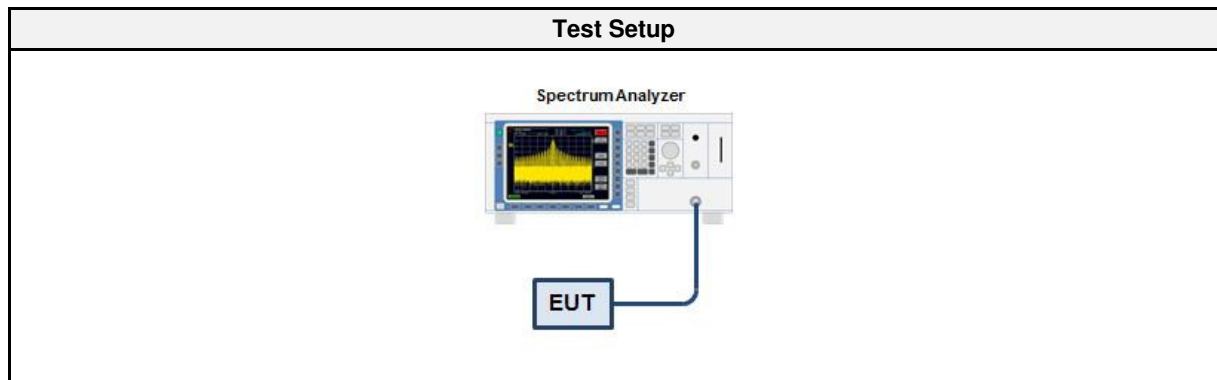

3.2.4 Equipment

Test Equipment					
Description	Manufacturer	Model	Identifier	Cal. Date	Cal. Due
Spectrum Analyzer	R&S	FSU 26	EF01003	2016-03	2017-03

3.2.5 Procedure

Test Procedure
<ol style="list-style-type: none"> 1. EUT set to test mode 2. Span set to at least twice the emission spectrum 3. Detector set to peak and max hold and RBW is set to 100 kHz 4. Envelope peak value of emission spectrum is selected 5. Marker on envelope of spectrum is set to level of -6 dB to the left of the peak 6. Marker on envelope of spectrum is set to level of -6 dB to the right of the peak 7. 6 dB Bandwidth is determined by marker frequency separation

3.2.6 Results

Test Results				
Mode	Frequency [MHz]	Bandwidth [kHz]	Limit [kHz]	Verdict
Transmit	912.5	607.5	≥ 500	PASS
Transmit	918.5	607.5	≥ 500	PASS

6 dB bandwidth – 912.5 MHz

DTS (6 dB) Bandwidth

Project Number: G0M-1701-6190
 Applicant: Kamstrup A/S
 Model Description: READy Converter for US/Canada market
 Model: READy Converter
 Test Sample ID: 12039
 Reference Standards: FCC 15.247, RSS-247
 Reference Method: ANSI C63.10:2013, Section 11.8.1 Option 1
 Operational Mode: 2_FSK, Channel: 912.5 MHz
 Operating Conditions: Tnom/Vnom
 Operator: W. Treffke
 Test Site: Eurofins Product Service GmbH
 Test Date: 2017-02-15
 Lower Frequency [MHz]: 912.197
 Upper Frequency [MHz]: 912.805
 6 dB Bandwidth [kHz]: 607

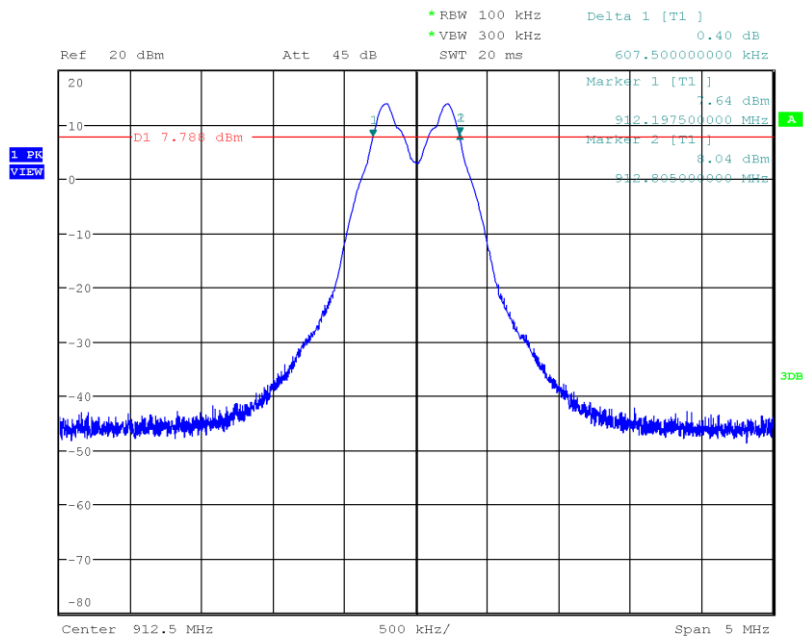

Date: 15.FEB.2017 08:56:04

6 dB bandwidth – 918.5 MHz

DTS (6 dB) Bandwidth

Project Number: G0M-1701-6190
 Applicant: Kamstrup A/S
 Model Description: READy Converter for US/Canada market
 Model: READy Converter
 Test Sample ID: 12039
 Reference Standards: FCC 15.247, RSS-247
 Reference Method: ANSI C63.10:2013, Section 11.8.1 Option 1
 Operational Mode: 2-FSK, Channel: 918.5 MHz
 Operating Conditions: Tnom/Vnom
 Operator: W. Treffke
 Test Site: Eurofins Product Service GmbH
 Test Date: 2017-02-15
 Lower Frequency [MHz]: 918.196
 Upper Frequency [MHz]: 918.804
 6 dB Bandwidth [kHz]: 608

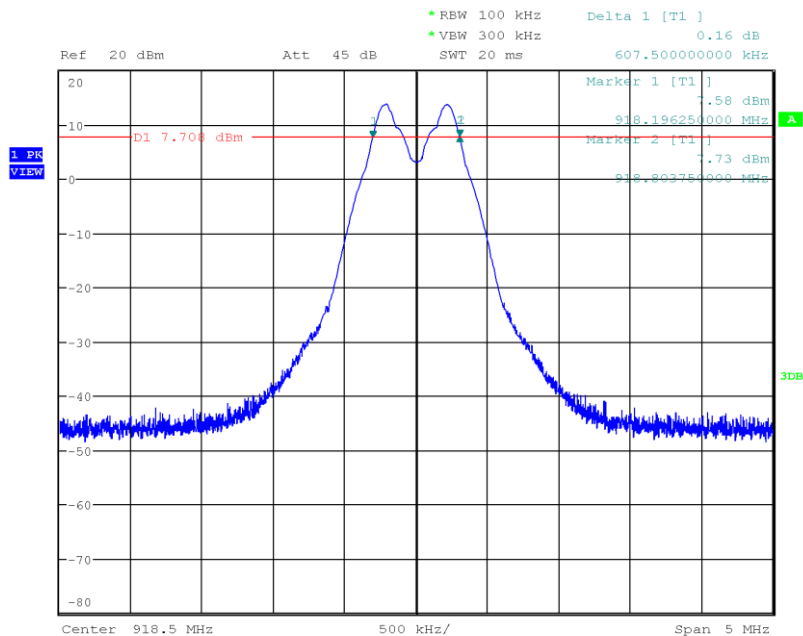

Date: 15.FEB.2017 11:49:18

3.3 Test Conditions and Results - Maximum peak conducted output power

3.3.1 Information

Test Information	
Reference	FCC 15.247(b)(1) / ISED RSS-247 5.4
Measurement Method	ANSI C63.10 11.9.1

3.3.2 Limits

Limits
1 W (30 dBm)
The conducted output power limit specified above is based on the use of antennas with directional gains that do not exceed 6 dBi. If transmitting antennas of directional gain greater than 6 dBi are used, the conducted output power from the intentional radiator shall be reduced below the stated values in the table, as appropriate, by the amount in dB that the directional gain of the antenna exceeds 6 dBi.

3.3.3 Setup

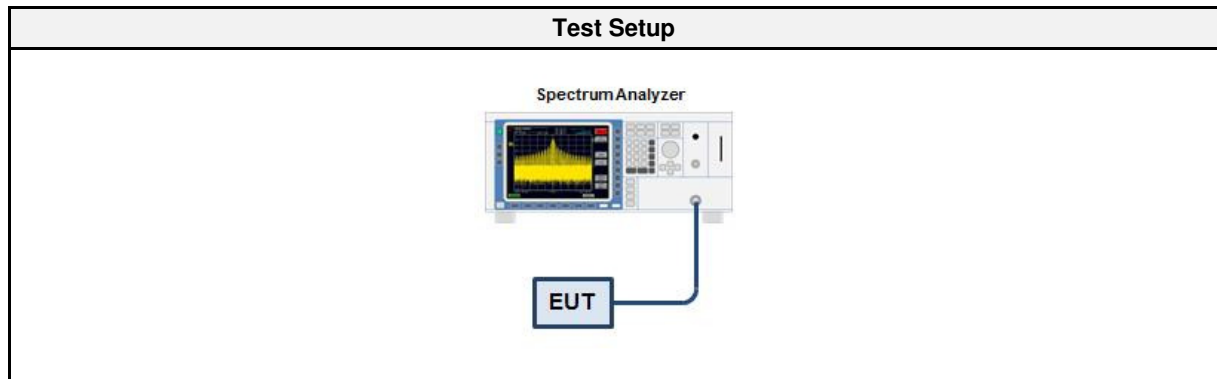

3.3.4 Equipment

Test Equipment					
Description	Manufacturer	Model	Identifier	Cal. Date	Cal. Due
Spectrum Analyzer	R&S	FSU 26	EF01003	2016-03	2017-03

3.3.5 Procedure

Test Procedure
<ol style="list-style-type: none"> EUT set to test hopping mode (Communication tester is used if needed) Analyzer resolution bandwidth is set \geq DTS bandwidth Detector set to peak and max hold Sweep time is set to auto After the trace has stabilized a marker is set to peak of envelope

3.3.6 Results

Test Results				
Channel [MHz]	Power [dBm]	Power [W]	Limit [W]	Verdict
912.5	14.4	0.027708	1.0	PASS
918.5	14.3	0.026897	1.0	PASS

3.4 Test Conditions and Results - Power spectral density

3.4.1 Information

Test Information	
Reference	FCC 15.247(e) / ISED RSS-247 5.2
Measurement Method	ANSI C63.10 11.10.2, 14.3.2

3.4.2 Limits

Limits
8 dBm / 3 kHz

3.4.3 Setup

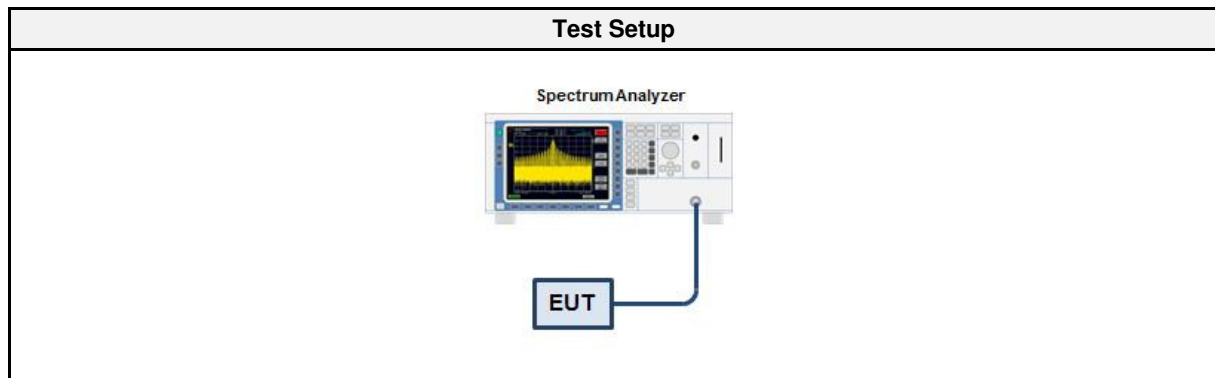

3.4.4 Equipment

Test Equipment					
Description	Manufacturer	Model	Identifier	Cal. Date	Cal. Due
Spectrum Analyzer	R&S	FSU 26	EF01003	2016-03	2017-03

3.4.5 Procedure

Test Procedure
<ol style="list-style-type: none"> 1. EUT set to test mode 2. The analyzer is set to DTS channel center frequency with a span of 1.5 times the DTS bandwidth 3. The RBW is set to 100 kHz with VBW \geq RBW and the detector is set to peak with max hold 4. After the trace has stabilized a marker is set to the envelope maximum 5. If the power spectral density is above the limit the RBW is reduced (not lower than 3 kHz) and the measurement is repeated 6. If the EUT has more than one transmit chain the procedure is repeated for each transmit chain

3.4.6 Results

Test Results			
Channel [MHz]	PSD [dBm/RBW]	Limit [dBm/3kHz]	Verdict
912.5	5.670	8.0	PASS
918.5	6.262	8.0	PASS
RBW = 100 kHz			

PSD conducted – 912.5 MHz

Peak Power Spectral Density

Project Number: G0M-1701-6190
 Applicant: Kamstrup A/S
 Model Description: READy Converter for US/Canada market
 Model: READy Converter
 Test Sample ID: 12039
 Reference Standards: FCC 15.247, RSS-247
 Reference Method: ANSI C63.10:2013, Section 11.10.2
 Operational Mode: 2-FSK, Channel: 912.5 MHz
 Operating Conditions: Tnom/Vnom
 Operator: W. Treffke
 Test Site: Eurofins Product Service GmbH
 Test Date: 2017-02-15
 Peak Frequency [MHz]: 912.268
 Spectral Density [dBm/RBW]: 5.670
 Resolution Bandwidth [kHz]: 3 kHz

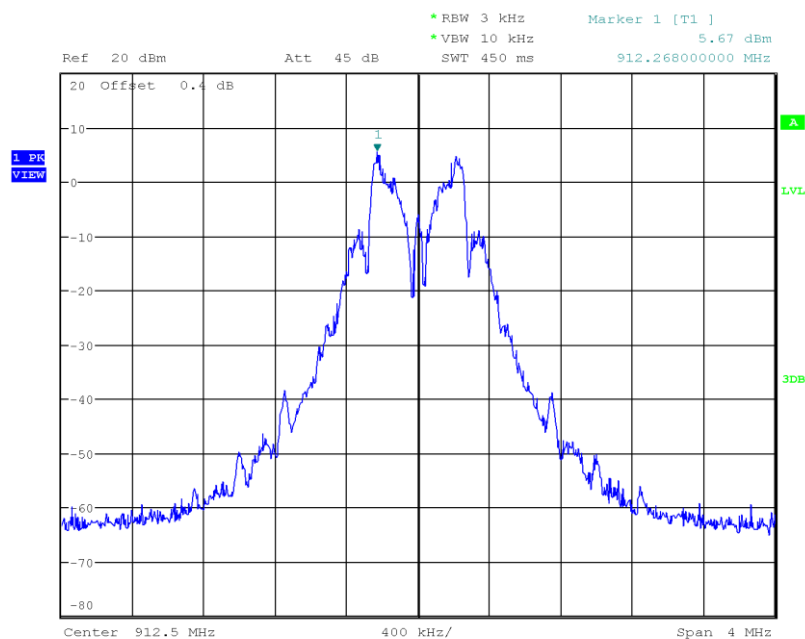

Date: 15.FEB.2017 09:23:13

PSD conducted – 918.5 MHz

Peak Power Spectral Density

Project Number: G0M-1701-6190
 Applicant: Kamstrup A/S
 Model Description: READy Converter for US/Canada market
 Model: READy Converter
 Test Sample ID: 12039
 Reference Standards: FCC 15.247, RSS-247
 Reference Method: ANSI C63.10:2013, Section 11.10.2
 Operational Mode: 2-FSK, Channel: 918.5 MHz
 Operating Conditions: Tnom/Vnom
 Operator: W. Treffke
 Test Site: Eurofins Product Service GmbH
 Test Date: 2017-02-15
 Peak Frequency [MHz]: 918.728
 Spectral Density [dBm/RBW]: 6.262
 Resolution Bandwidth [kHz]: 3 kHz

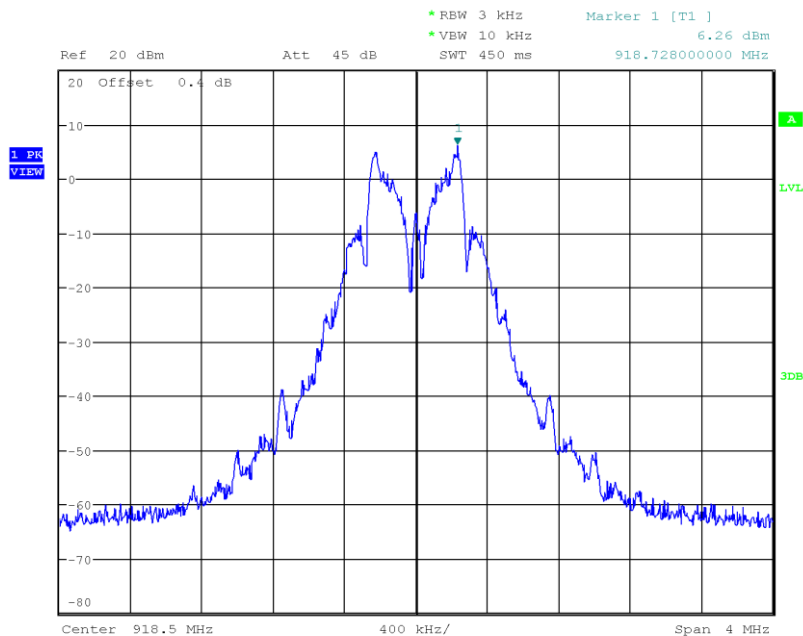

Date: 15.FEB.2017 12:00:49

3.5 Test Conditions and Results - AC powerline conducted emissions

3.5.1 Information

Test Information	
Reference	FCC 15.207
Measurement Method	ANSI C63.10 6.2

3.5.2 Limits

Limits		
Frequency [MHz]	Quasi-Peak [dB μ V]	Average [dB μ V]
0.15 - 0.5	66 - 56*	56 - 46*
0.5 - 5	56	46
5 - 30	60	50

* Limit decreases linearly with the logarithm of the frequency

3.5.3 Setup

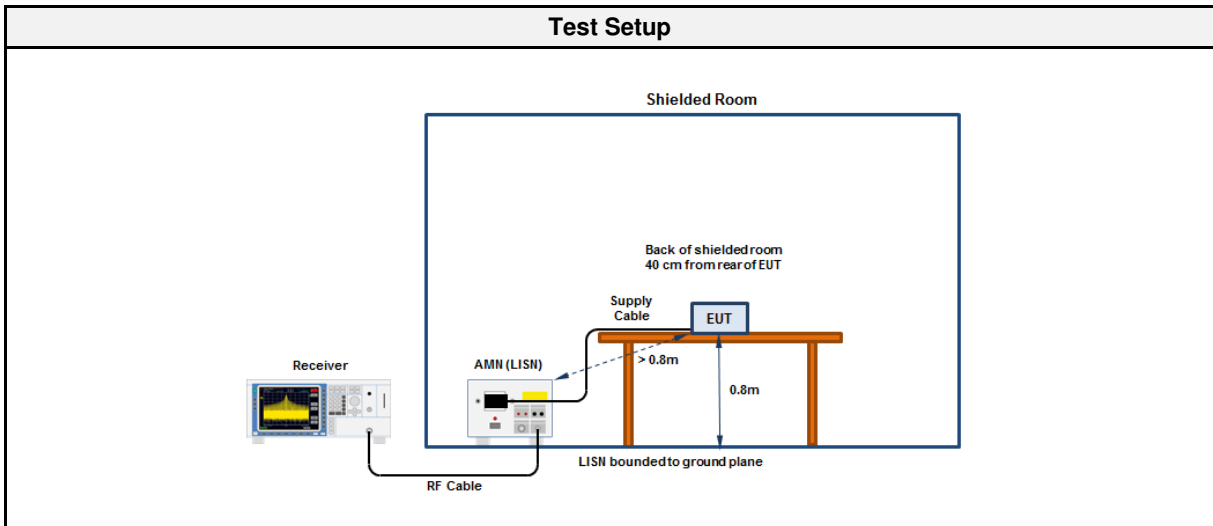

3.5.4 Equipment

Test Equipment					
Description	Manufacturer	Model	Identifier	Cal. Date	Cal. Due
EMI Receiver	R&S	ESR7	EF00943	2016-10	2017-10
LISN	R&S	ESH2-Z5	EF00182	2017-01	2019-01
LISN	R&S	ESH3-Z5	EF00036	2017-01	2019-01

Conducted Emissions A

EMI voltage test in the ac-mains according to FCC 15B

Project number: G0M-1701-6190

Applicant: Kamstrup A/S
 EUT Name: READy Converter for US/Canada market
 Model: READy Converter
 Test Site: Eurofins Product Service GmbH
 Operator: Mr. Handrik
 Test Conditions: Tnom: 21°C, Unom: 120V AC
 LISN: ESH2-Z5 N
 Mode: Mode# 2
 Test Date: 2017-02-15
 Note: Roof top antenna

Index 78

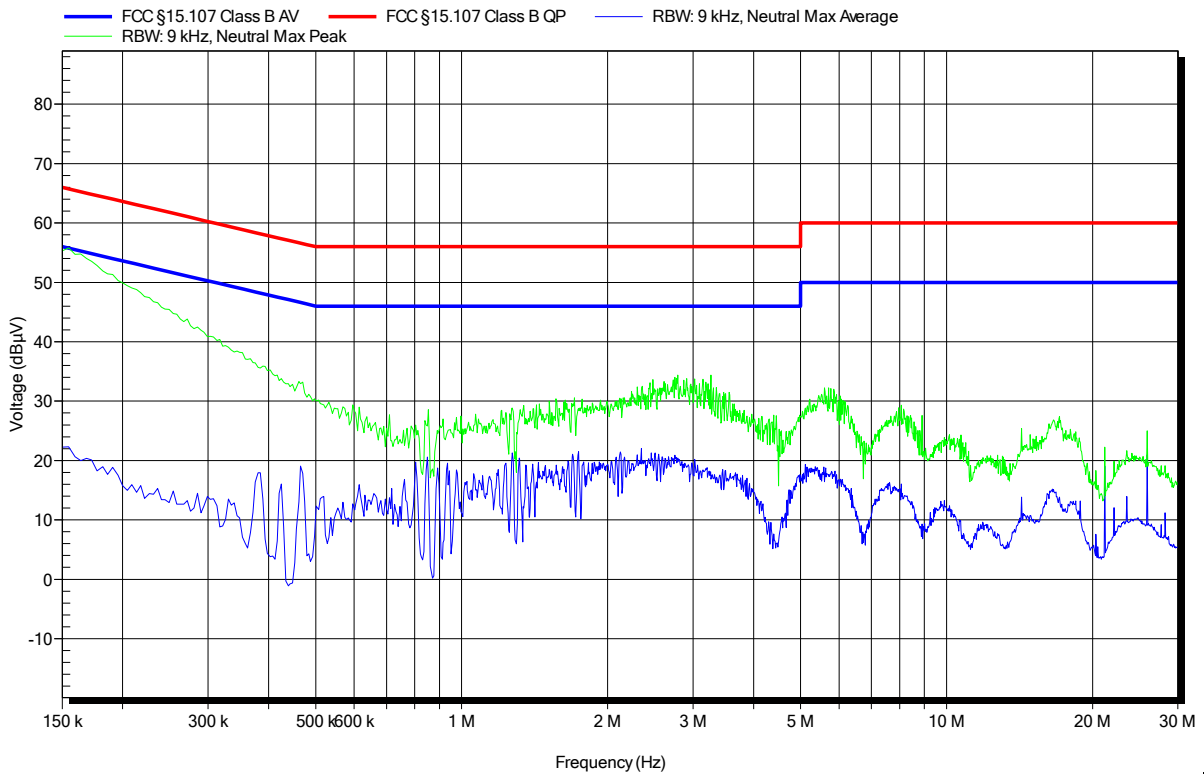

Conducted Emissions B

EMI voltage test in the ac-mains according to FCC 15B

Project number: G0M-1701-6190

Applicant: Kamstrup A/S
 EUT Name: READy Converter for US/Canada market
 Model: READy Converter
 Test Site: Eurofins Product Service GmbH
 Operator: Mr. Handrik
 Test Conditions: Tnom: 21°C, Unom: 120V AC
 LISN: ESH2-Z5 L
 Mode: Mode# 2
 Test Date: 2017-02-15
 Note: Roof top antenna

Index 79

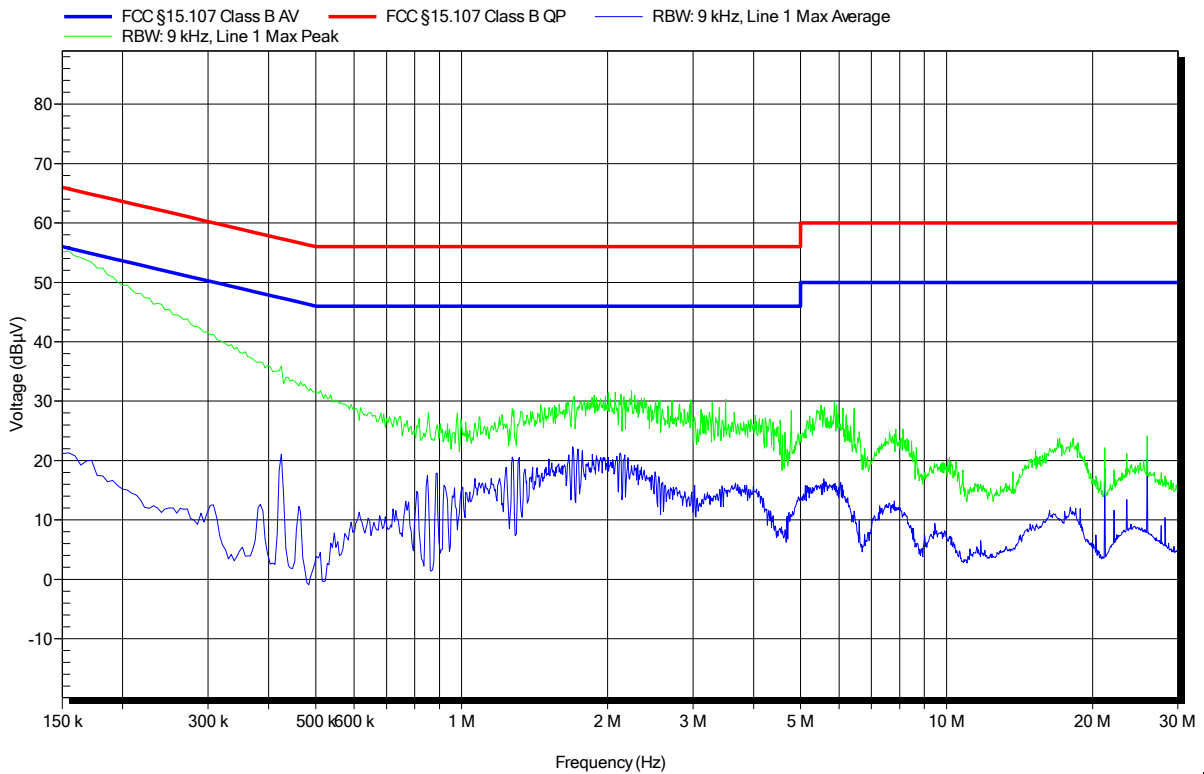

3.6 Test Conditions and Results - Band-edge compliance

3.6.1 Information

Test Information	
Reference	FCC 15.247(d) / ISED RSS-247 5.5
Measurement Method	ANSI C63.10 11.11

3.6.2 Limits

Limits	
Power Measurement	Out-of-band attenuation [dB]
Peak	20
Average	30

3.6.3 Setup

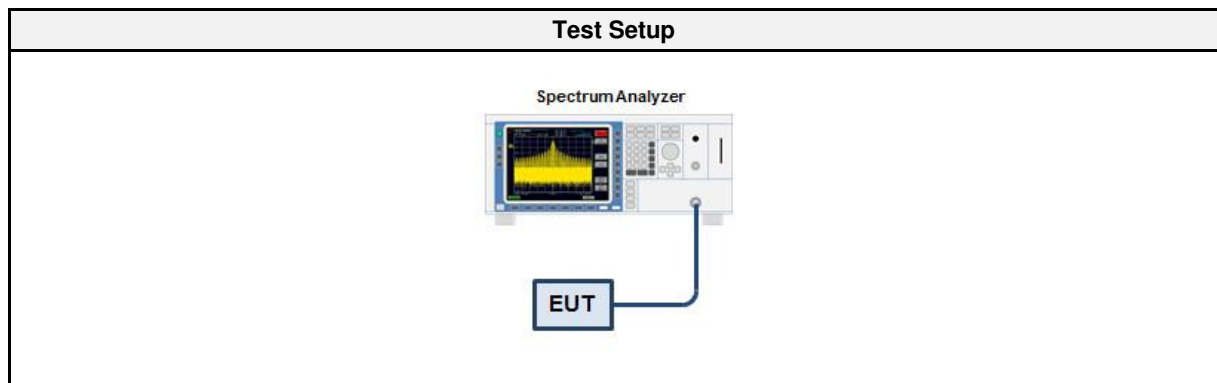

3.6.4 Equipment

Test Equipment					
Description	Manufacturer	Model	Identifier	Cal. Date	Cal. Due
Spectrum Analyzer	R&S	FSU 26	EF01003	2016-03	2017-03

3.6.5 Procedure

Test Procedure
<ol style="list-style-type: none"> 1. EUT set to test mode (Communication tester is used if needed) 2. Span set around lower band edge and detector is set to peak and max hold 3. Resolution bandwidth is set to 100 kHz 4. Markers are set to peak emission levels within frequency band and outside frequency band 5. Band edge attenuation is determined from level difference

3.6.6 Results

Test Results				
Mode	Channel [MHz]	Out-of-band Attenuation [dB]	Limit [dB]	Verdict
Transmit-PS	912.5	-55.38	-20	PASS
Transmit-PS	918.5	-56.82	-20	PASS

Band-edge compliance - 912.5 MHz

Band-edge Compliance

Project Number: G0M-1701-6190
 Applicant: Kamstrup A/S
 Model Description: READy Converter for US/Canada market
 Model: READy Converter
 Test Sample ID: 12039
 Reference Standards: FCC 15.247, RSS-247
 Reference Method: ANSI C63.10:2013, Section 11.11
 Operational Mode: 2-FSK, Channel: 912.5 MHz
 Operating Conditions: Tnom/Vnom
 Operator: W. Treffke
 Test Site: Eurofins Product Service GmbH
 Test Date: 2017-02-15
 Band-edge: Lower
 In-band Frequency [MHz]: 912.3
 Max. in-band Level [dBm/100 kHz]: 14.19
 Out-of-band Frequency [MHz]: 899.18
 Max. out-of-band Level [dBm/100 kHz]: -41.194
 Attenuation [dB]: -55.38

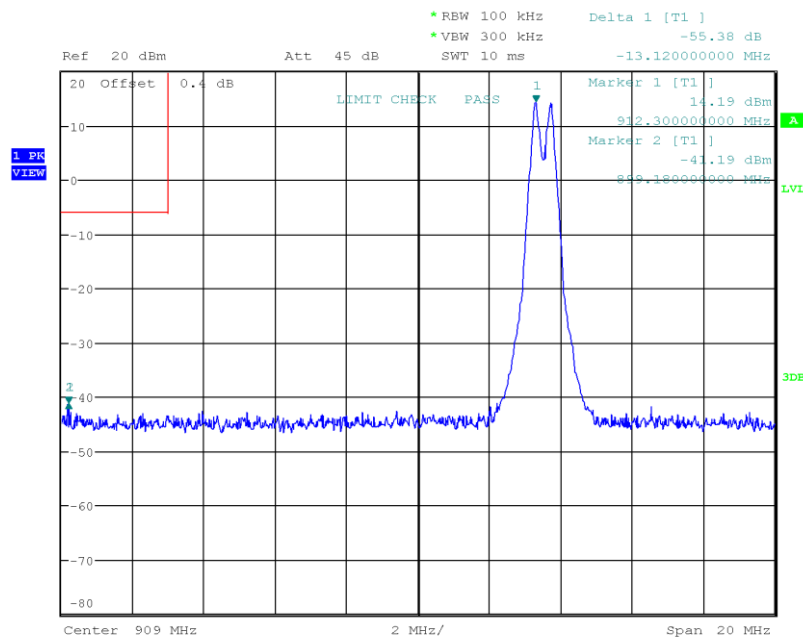

Date: 15.FEB.2017 10:13:11

Band-edge compliance - 918.5 MHz

Band-edge Compliance

Project Number: G0M-1701-6190
 Applicant: Kamstrup A/S
 Model Description: READy Converter for US/Canada market
 Model: READy Converter
 Test Sample ID: 12039
 Reference Standards: FCC 15.247, RSS-247
 Reference Method: ANSI C63.10:2013, Section 11.11
 Operational Mode: 2-FSK, Channel: 918.5 MHz
 Operating Conditions: Tnom/Vnom
 Operator: W. Treffke
 Test Site: Eurofins Product Service GmbH
 Test Date: 2017-02-15
 Band-edge: Upper
 In-band Frequency [MHz]: 918.277
 Max. in-band Level [dBm/100 kHz]: 14.101
 Out-of-band Frequency [MHz]: 929.634
 Max. out-of-band Level [dBm/100 kHz]: -42.717
 Attenuation [dB]: -56.82

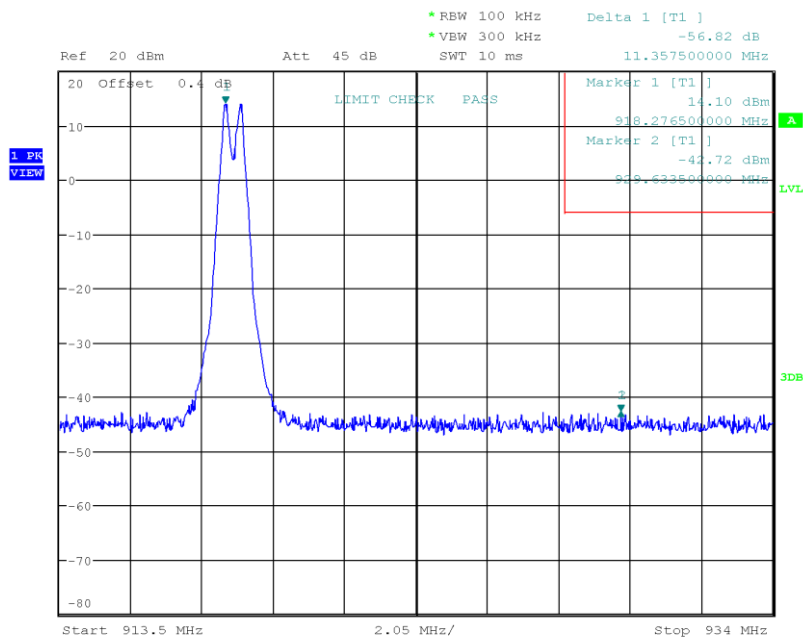

Date: 15.FEB.2017 11:42:05

3.7 Test Conditions and Results - Conducted spurious emissions

3.7.1 Information

Test Information	
Reference	FCC 15.247(d) / ISED RSS-247 5.5
Measurement Method	ANSI C63.10 11.11

3.7.2 Limits

Limits	
Power Measurement	Out-of-band attenuation [dB]
Peak	20
Average	30

3.7.3 Setup

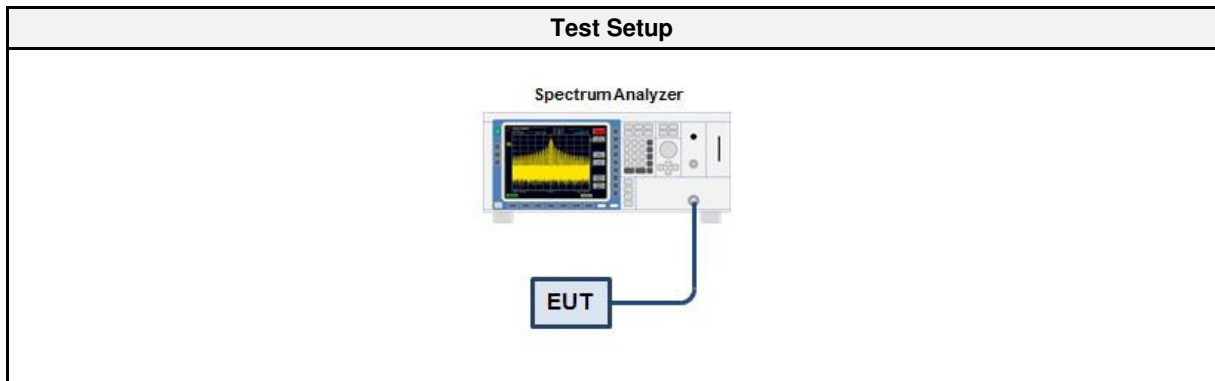

3.7.4 Equipment

Test Equipment					
Description	Manufacturer	Model	Identifier	Cal. Date	Cal. Due
Spectrum Analyzer	R&S	FSU 26	EF01003	2016-03	2017-03

3.7.5 Procedure

Test Procedure
<ol style="list-style-type: none"> EUT set to test mode (Communication tester is used if needed) Span set around lower band edge and detector is set to peak and max hold Resolution bandwidth is set to 100 kHz Markers are set to peak emission levels within frequency band and outside frequency band Band edge attenuation is determined from level difference

3.7.6 Results

Test Results		
Mode	Channel [MHz]	Verdict
Transmit-PS	912.5	PASS
Transmit-PS	918.5	PASS

CSE - 912.5 MHz

Conducted Spurious Emissions

Project Number: G0M-1701-6190
 Applicant: Kamstrup A/S
 Model Description: READy Converter for US/Canada market
 Model: READy Converter
 Test Sample ID: 12039
 Reference Standards: FCC 15.247, RSS-247
 Reference Method: ANSI C63.10:2013, Section 11.11
 Operational Mode: 2-FSK, Channel: 912.5 MHz
 Operating Conditions: Tnom/Vnom
 Operator: W. Treffke
 Test Site: Eurofins Product Service GmbH
 Test Date: 2017-02-15
 Max. in-band Frequency [MHz]: 912.3
 Max. in-band Level [dBm/100 kHz]: 14.1
 Out-of-band Limit [dBm/100 kHz]: -5.9

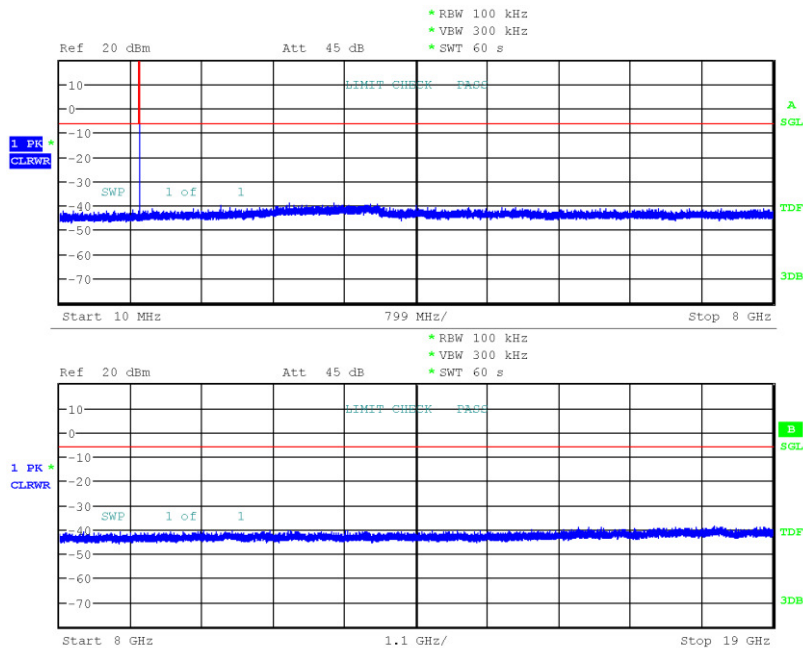

Date: 15.FEB.2017 10:39:08

CSE - 918.5 MHz

Conducted Spurious Emissions

Project Number: G0M-1701-6190
 Applicant: Kamstrup A/S
 Model Description: READy Converter for US/Canada market
 Model: READy Converter
 Test Sample ID: 12039
 Reference Standards: FCC 15.247, RSS-247
 Reference Method: ANSI C63.10:2013, Section 11.11
 Operational Mode: 2-FSK, Channel: 918.5 MHz
 Operating Conditions: Tnom/Vnom
 Operator: W. Treffke
 Test Site: Eurofins Product Service GmbH
 Test Date: 2017-02-15
 Max. in-band Frequency [MHz]: 918.3
 Max. in-band Level [dBm/100 kHz]: 14.0
 Out-of-band Limit [dBm/100 kHz]: -6.0

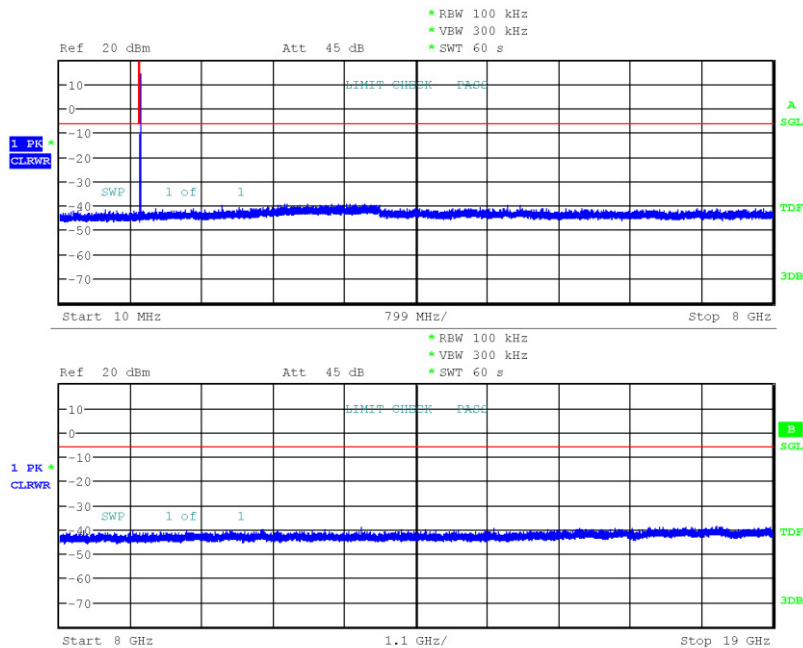

Date: 15.FEB.2017 11:03:29

3.8 Test Conditions and Results - Transmitter radiated emissions

3.8.1 Information

Test Information	
Reference	FCC 15.247(d) / ISED RSS-247 5.5
Measurement Method	ANSI C63.10 6.4, 6.5, 6.6, 11.12

3.8.2 Limits

Limits		
Frequency [MHz]	Field strength [dB μ V/m]	Measurement distance [m]
0.009 - 0.490	2400/F[kHz]	300
0.490 - 1.705	24000/F[kHz]	30
1.705 - 30.0	30	30
30 - 88	100	3
88 - 216	150	3
216 - 960	200	3
> 960	500	3

3.8.3 Setup

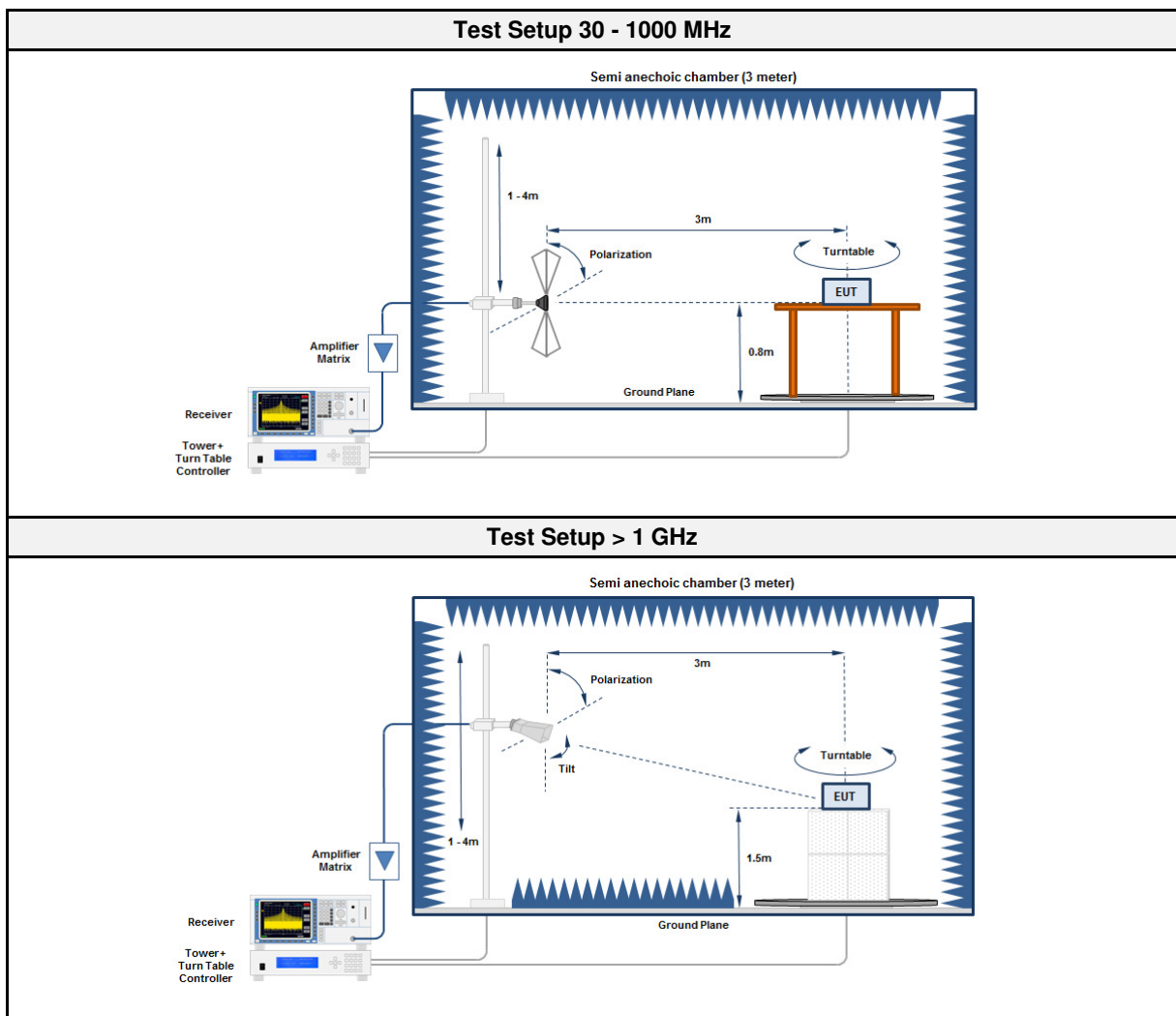

3.8.4 Equipment

Test Equipment 30 - 1000 MHz					
Description	Manufacturer	Model	Identifier	Cal. Date	Cal. Due
Anechoic Chamber	Frankonia	AC1	EF00062	2016-01	2019-01
Measurement Receiver	R&S	MXE EMI Receiver	EF01070	2016-08	2017-08
Biconical Antenna	R&S	HK116	EF00203	2016-06	2018-06
LPD antenna	R&S	HL223	EF00187	2016-05	2019-05
Test Equipment > 1 GHz					
Description	Manufacturer	Model	Identifier	Cal. Date	Cal. Due
Anechoic Chamber	Frankonia	AC1	EF00062	2016-01	2019-01
Measurement Receiver	R&S	MXE EMI Receiver	EF01070	2016-08	2017-08
Horn antenna	Schwarzbeck	BBHA9120D	EF00019	2016-09	2018-09
Horn antenna	Amplifier Research	ATH18G40	EF01152	2016-09	2017-09

3.8.5 Procedure

Test Procedure 30 - 1000 MHz
<ol style="list-style-type: none"> EUT is placed on a non-conducting support at the center of a turn table 0.8 m above the ground EUT set to test mode The receiver is set to peak detection with max hold The EUT is rotated through 360° and the height of the antenna is varied from 1 m to 4 m All significant emissions are measured again using the corresponding final detector
Test Procedure > 1 GHz
<ol style="list-style-type: none"> EUT is placed on a non-conducting support at the center of a turn table 1.5 m above the ground EUT set to test mode The receiver is set to peak detection with max hold The EUT is rotated through 360° and the height of the antenna is varied from 1 m to 4 m All significant emissions are measured again using the corresponding final detector

3.8.6 Results

Test Results - Roof top antenna						
Channel [MHz]	Emission [MHz]	Level [dBμV/m]	Det.	Pol.	Limit [dBμV/m]	Margin [dB]
912.5	1822	38.27	pk	hor	95.00	-56.73
912.5	1822	52.19	pk	ver	95.00	-42.81
912.5	2734	30.73	pk	hor	74.00	-43.27
912.5	2734	34.26	pk	ver	74.00	-39.74
918.5	1834	45.03	pk	hor	95.00	-49.97
918.5	1834	58.25	pk	ver	95.00	-36.75
918.5	1936	34.40	pk	hor	95.00	-60.60
918.5	2410	31.07	pk	ver	95.00	-63.93
918.5	2752	31.88	pk	hor	74.00	-42.12
918.5	2752	37.11	pk	ver	74.00	-36.89

Test Results - Whip antenna						
Channel [MHz]	Emission [MHz]	Level [dB μ V/m]	Det.	Pol.	Limit [dB μ V/m]	Margin [dB]
912.5	1822	32.93	pk	hor	95.00	-62.07
912.5	1822	38.18	pk	ver	95.00	-56.82
912.5	2398	31.29	pk	ver	95.00	-63.71
912.5	2734	36.35	pk	hor	74.00	-37.65
912.5	2734	38.31	pk	ver	74.00	-35.69
918.5	1834	34.93	pk	hor	95.00	-60.07
918.5	1834	43.60	pk	ver	95.00	-51.40
918.5	2398	30.75	pk	ver	95.00	-64.25
918.5	2752	36.72	pk	hor	74.00	-37.28
918.5	2752	39.43	pk	ver	74.00	-34.57

3.9 Test Conditions and Results - Receiver radiated emissions

3.9.1 Information

Test Information	
Reference	ISED RSS-247 3.1
Measurement Method	ANSI C63.10 6.5, 6.6, 11.12

3.9.2 Limits

Limits		
Frequency [MHz]	Field strength [dB μ V/m]	Measurement distance [m]
30 - 88	100	3
88 - 216	150	3
216 - 960	200	3
> 960	500	3

3.9.3 Setup

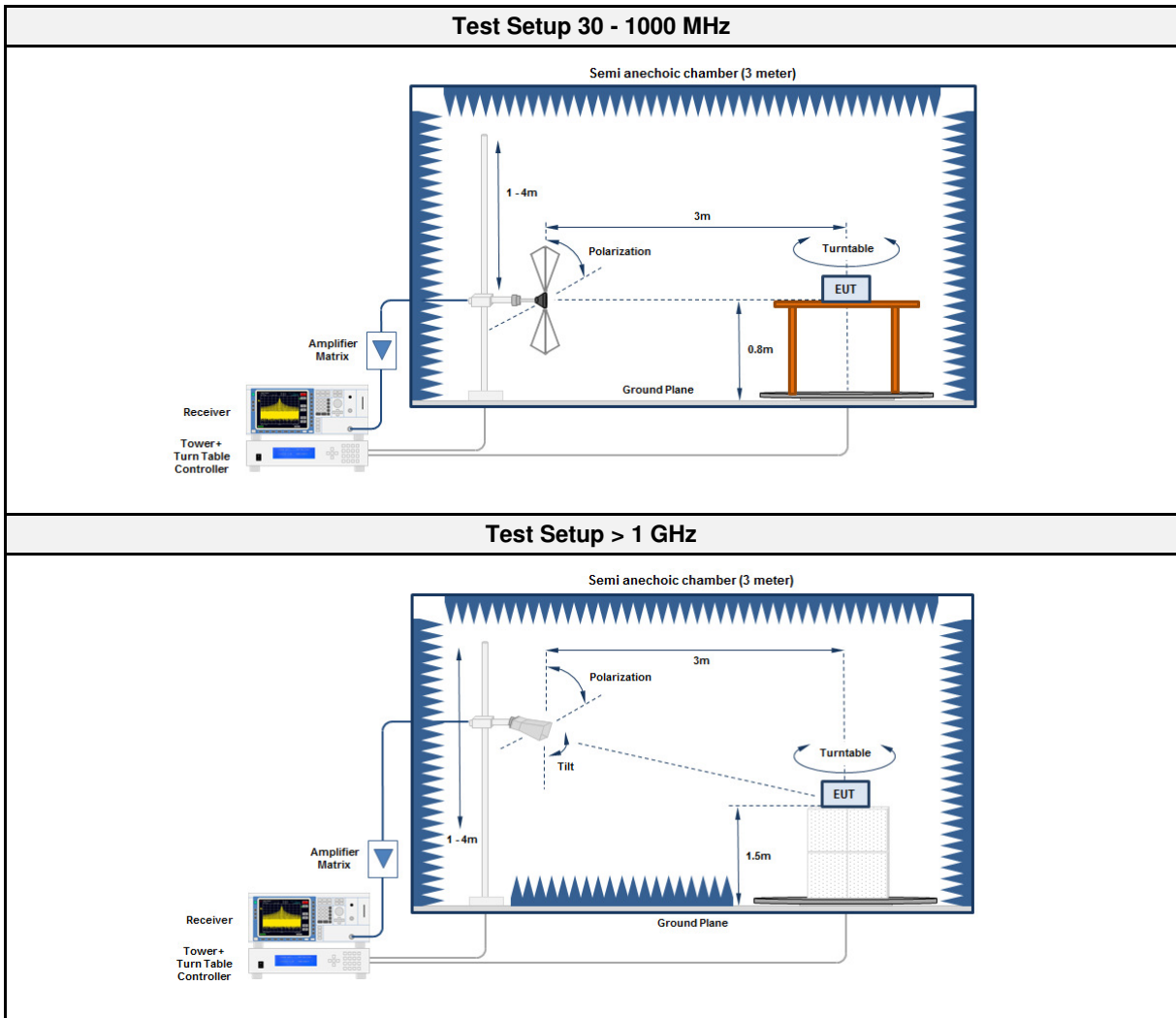

3.9.4 Equipment

Test Equipment 30 - 1000 MHz					
Description	Manufacturer	Model	Identifier	Cal. Date	Cal. Due
Anechoic Chamber	Frankonia	AC1	EF00062	2016-01	2019-01
Measurement Receiver	R&S	MXE EMI Receiver	EF01070	2016-08	2017-08
Biconical Antenna	R&S	HK116	EF00203	2016-06	2018-06
LPD antenna	R&S	HL223	EF00187	2016-05	2019-05
Test Equipment > 1 GHz					
Description	Manufacturer	Model	Identifier	Cal. Date	Cal. Due
Anechoic Chamber	Frankonia	AC1	EF00062	2016-01	2019-01
Measurement Receiver	R&S	MXE EMI Receiver	EF01070	2016-08	2017-08
Horn antenna	Schwarzbeck	BBHA9120D	EF00019	2016-09	2018-09
Horn antenna	Amplifier Research	ATH18G40	EF01152	2016-09	2017-09

3.9.5 Procedure

Test Procedure 30 - 1000 MHz
<ol style="list-style-type: none"> EUT is placed on a non-conducting support at the center of a turn table 0.8 m above the ground EUT set to test mode The receiver is set to peak detection with max hold The EUT is rotated through 360° and the height of the antenna is varied from 1 m to 4 m All significant emissions are measured again using the corresponding final detector

Test Procedure > 1 GHz
<ol style="list-style-type: none"> EUT is placed on a non-conducting support at the center of a turn table 1.5 m above the ground EUT set to test mode The receiver is set to peak detection with max hold The EUT is rotated through 360° and the height of the antenna is varied from 1 m to 4 m All significant emissions are measured again using the corresponding final detector

3.9.6 Results

Test Results - Roof top antenna						
Channel [MHz]	Emission [MHz]	Level [dBμV/m]	Det.	Pol.	Limit [dBμV/m]	Margin [dB]
915	2398	42.38	pk	ver	53.98	-11.60

Test Results - Whip antenna						
Channel [MHz]	Emission [MHz]	Level [dBμV/m]	Det.	Pol.	Limit [dBμV/m]	Margin [dB]
915	2398	42.18	pk	ver	53.98	-11.80

ANNEX A Transmitter spurious emissions

Spurious emissions according to FCC 15.247

Project number: G0M-1701-6190

Applicant:	Kamstrup A/S
EUT Name:	READY Converter for US/Canada market
Model:	READY Converter
Test Site:	Eurofins Product Service GmbH
Operator:	Mr. Handrik
Test Conditions:	Tnom: 21°C, Vnom: 5V DC
Antenna:	Rohde & Schwarz HK 116, Horizontal
Measurement distance:	3 m
Mode:	TX; TX 912 .5 MHz
Test Date:	2017-02-14
Note:	Roof top antenna

Index 30

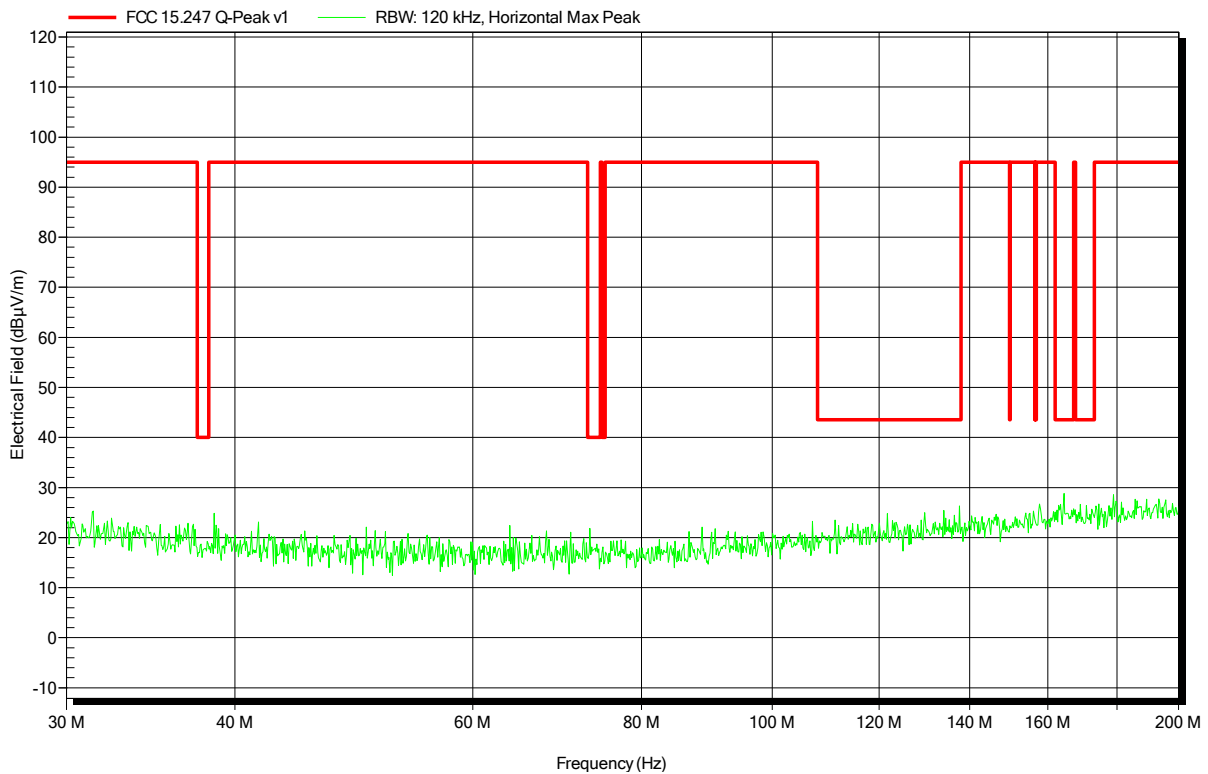

Spurious emissions according to FCC 15.247

Project number: G0M-1701-6190

Applicant: Kamstrup A/S
 EUT Name: READy Converter for US/Canada market
 Model: READy Converter
 Test Site: Eurofins Product Service GmbH
 Operator: Mr. Handrik
 Test Conditions: Tnom: 21°C, Vnom: 5V DC
 Antenna: Rohde & Schwarz HK 116, Vertical
 Measurement distance: 3 m
 Mode: TX; TX 912.5 MHz; ant: Laird Technology / Nearson
 Test Date: 2017-02-14
 Note: Roof top antenna

Index 25

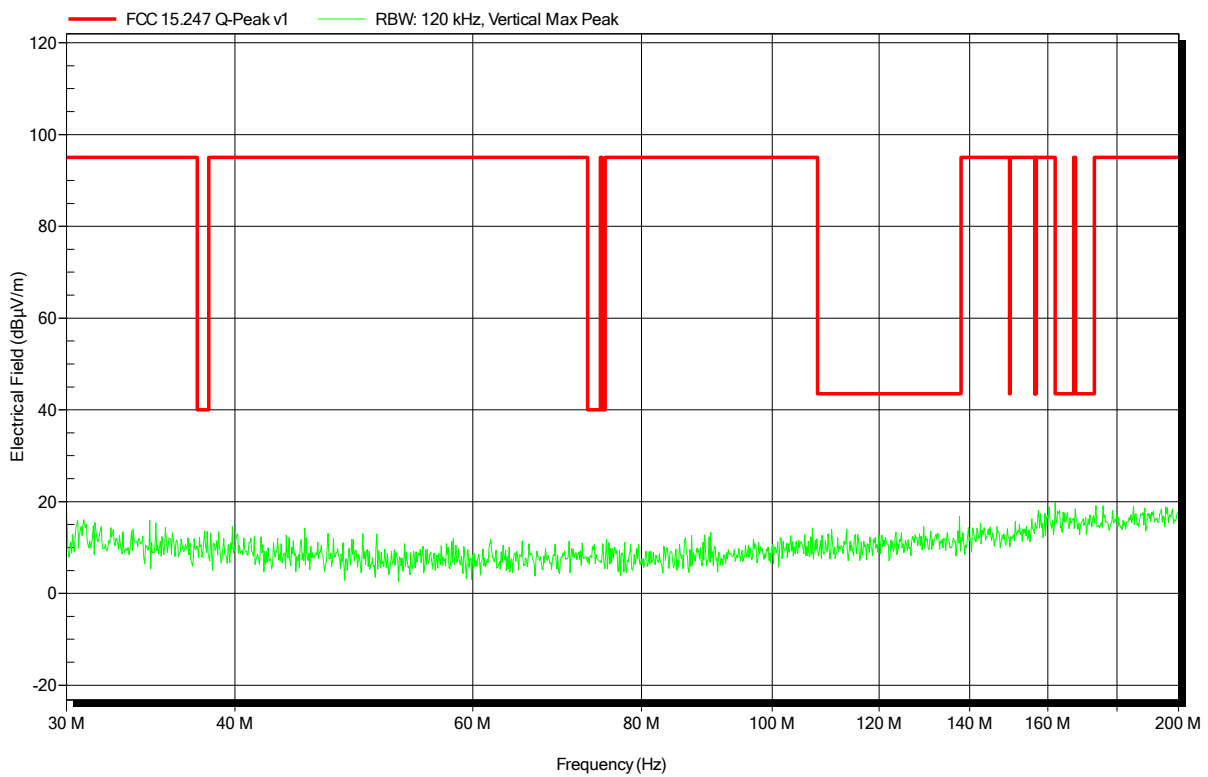

Spurious emissions according to FCC 15.247

Project number: G0M-1701-6190

Applicant: Kamstrup A/S
 EUT Name: READY Converter for US/Canada market
 Model: READY Converter
 Test Site: Eurofins Product Service GmbH
 Operator: Mr. Handrik
 Test Conditions: Tnom: 21°C, Vnom: 5V DC
 Antenna: Rohde & Schwarz HL 223, Horizontal
 Measurement distance: 3 m
 Mode: TX; TX 912.5 MHz: Laird Technology / Nearson
 Test Date: 2017-02-14
 Note: Roof top antenna

Index 51

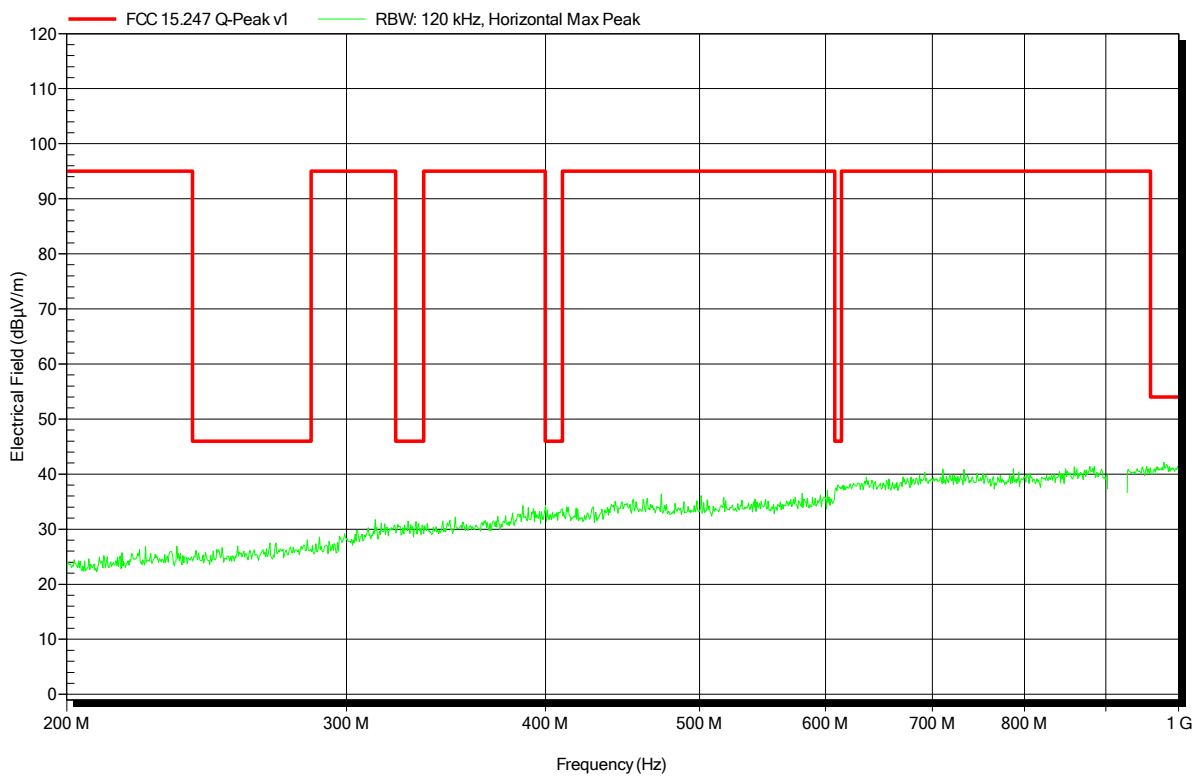

Spurious emissions according to FCC 15.247

Project number: G0M-1701-6190

Applicant: Kamstrup A/S
 EUT Name: READy Converter for US/Canada market
 Model: READy Converter
 Test Site: Eurofins Product Service GmbH
 Operator: Mr. Handrik
 Test Conditions: Tnom: 21°C, Vnom: 5V DC
 Antenna: Rohde & Schwarz HL 223, Vertical
 Measurement distance: 3 m
 Mode: TX; TX 912.5 MHz: Laird Technology / Nearson
 Test Date: 2017-02-14
 Note: Roof top antenna

Index 50

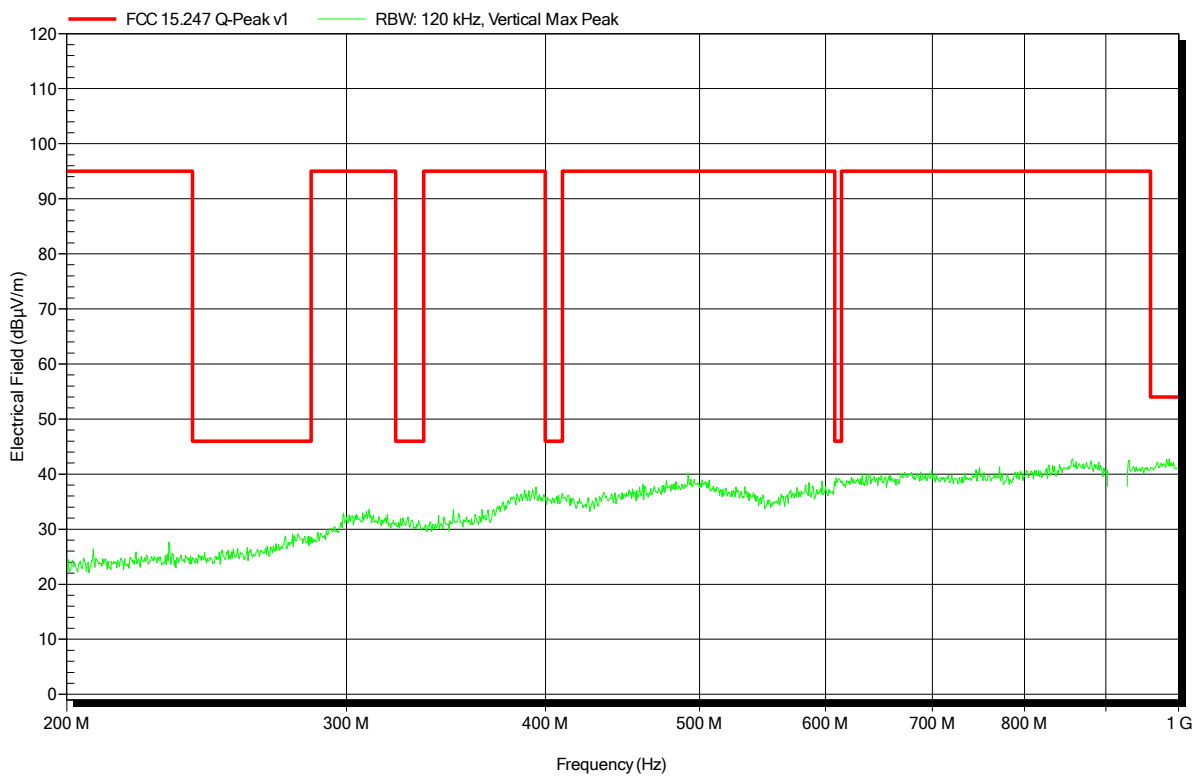

Spurious emissions according to FCC 15.247

Project number: G0M-1701-6190

Applicant: Kamstrup A/S
 EUT Name: READy Converter for US/Canada market
 Model: READy Converter
 Test Site: Eurofins Product Service GmbH
 Operator: Mr. Suckow
 Test Conditions: Tnom: 24°C, Vnom: 5.0 VDC
 Antenna: Rohde & Schwarz HL 223, Horizontal
 Measurement distance: 3 m
 Mode: TX; SRD 912.5 MHz
 Test Date: 2017-02-14
 Note: band-edge

Index 29

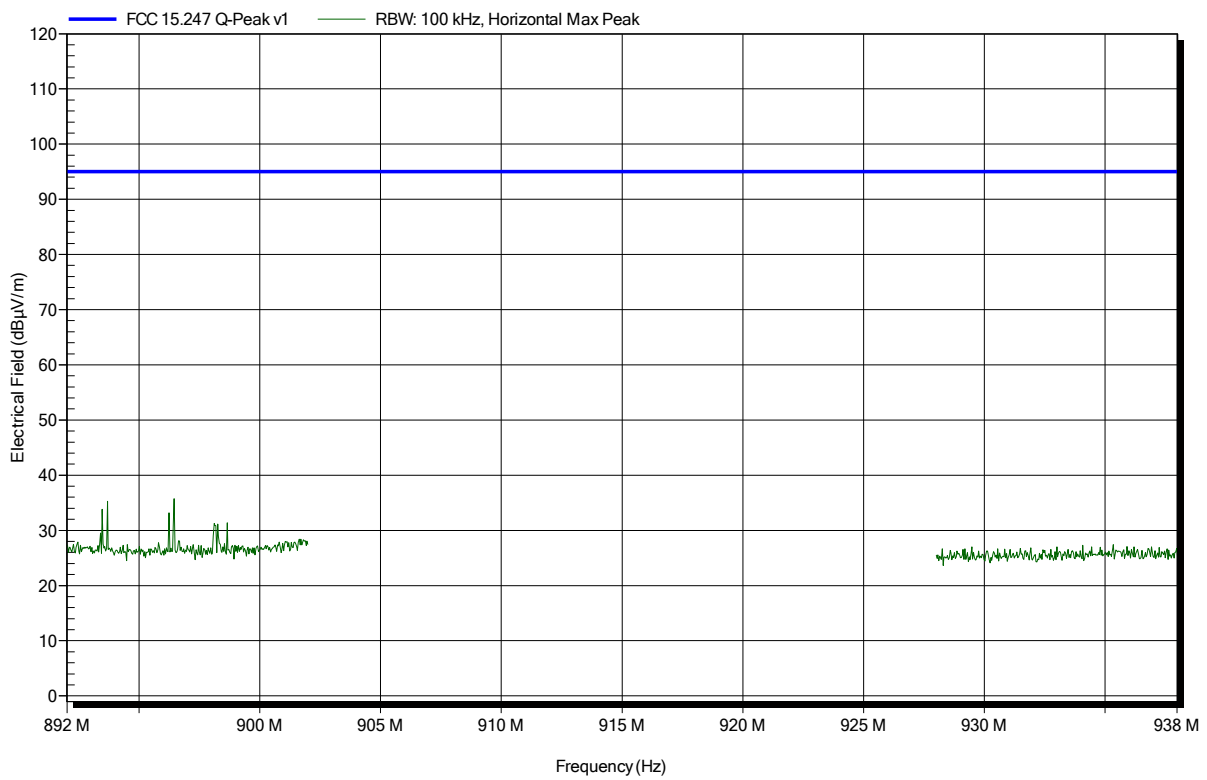

Spurious emissions according to FCC 15.247

Project number: G0M-1701-6190

Applicant: Kamstrup A/S
 EUT Name: READy Converter for US/Canada market
 Model: READy Converter
 Test Site: Eurofins Product Service GmbH
 Operator: Mr. Suckow
 Test Conditions: Tnom: 24°C, Vnom: 5.0 VDC
 Antenna: Rohde & Schwarz HL 223, Vertical
 Measurement distance: 3 m
 Mode: TX; SRD 912.5 MHz
 Test Date: 2017-02-14
 Note: band-edge

Index 27

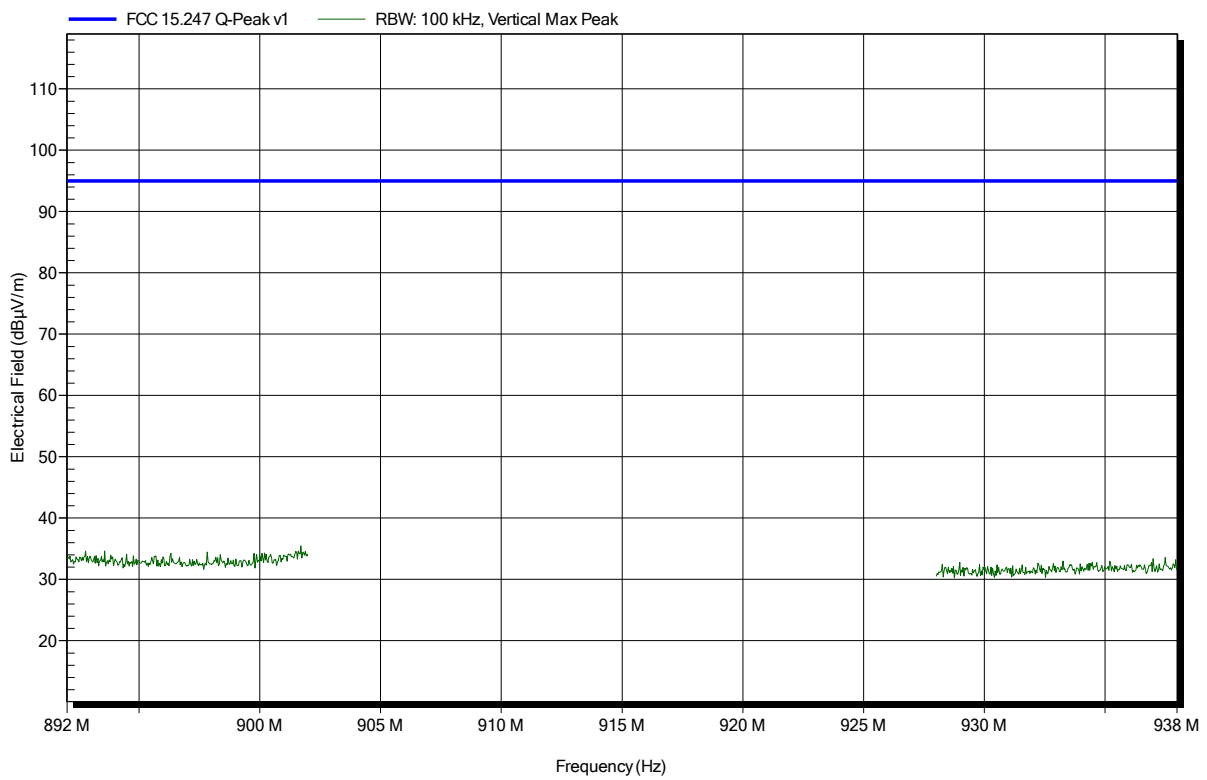

Spurious emissions according to FCC 15.247

Project number: G0M-1701-6190

Applicant: Kamstrup A/S
 EUT Name: READY Converter for US/Canada market
 Model: READY Converter
 Test Site: Eurofins Product Service GmbH
 Operator: Mr. Suckow
 Test Conditions: Tnom: 24°C, Vnom: 5.0 VDC
 Antenna: Schwarzbeck BBHA 9120D, Horizontal
 Measurement distance: 1 m
 Mode: TX; SRD 912.5 MHz
 Test Date: 2017-02-14
 Note: Roof top antenna

Index 65

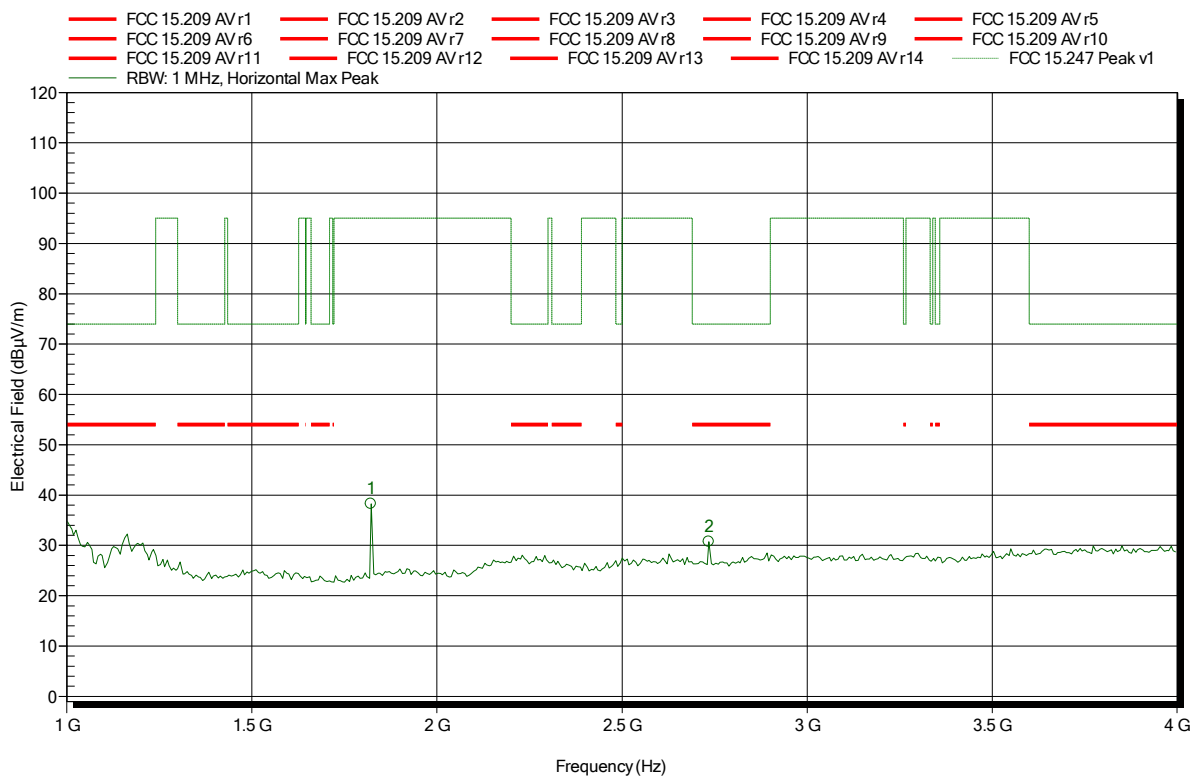

Frequency	Peak	Peak Limit	Peak Difference	Peak Status
1.822 GHz	38.27 dBµV/m	95 dBµV/m	-56.73 dB	Pass
2.734 GHz	30.73 dBµV/m	74 dBµV/m	-43.27 dB	Pass

Spurious emissions according to FCC 15.247

Project number: G0M-1701-6190

Applicant: Kamstrup A/S
 EUT Name: REAdy Converter for US/Canada market
 Model: REAdy Converter
 Test Site: Eurofins Product Service GmbH
 Operator: Mr. Suckow
 Test Conditions: Tnom: 24°C, Vnom: 5.0 VDC
 Antenna: Schwarzbeck BBHA 9120D, Vertical
 Measurement distance: 3 m
 Mode: TX; SRD 912.5 MHz
 Test Date: 2017-02-14
 Note: Roof top antenna

Index 64

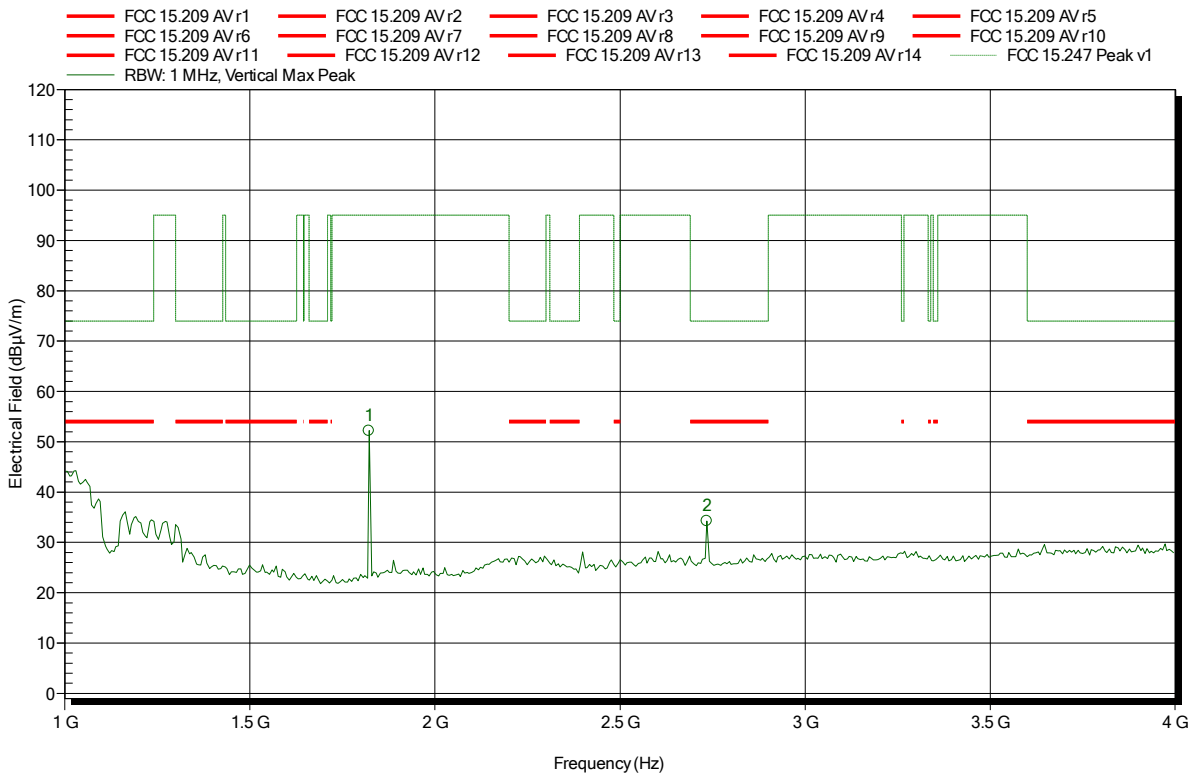

Frequency	Peak	Peak Limit	Peak Difference	Peak Status
1.822 GHz	52.19 dBµV/m	95 dBµV/m	-42.81 dB	Pass
2.734 GHz	34.26 dBµV/m	74 dBµV/m	-39.74 dB	Pass

Spurious emissions according to FCC 15.247

Project number: G0M-1701-6190

Applicant: Kamstrup A/S
 EUT Name: READy Converter for US/Canada market
 Model: READy Converter
 Test Site: Eurofins Product Service GmbH
 Operator: Mr. Suckow
 Test Conditions: Tnom: 24°C, Vnom: 5.0 VDC
 Antenna: Schwarzbeck BBHA 9120D, Horizontal
 Measurement distance: 1 m
 Mode: TX; SRD 912.5 MHz
 Test Date: 2017-02-14
 Note: Roof top antenna

Index 66

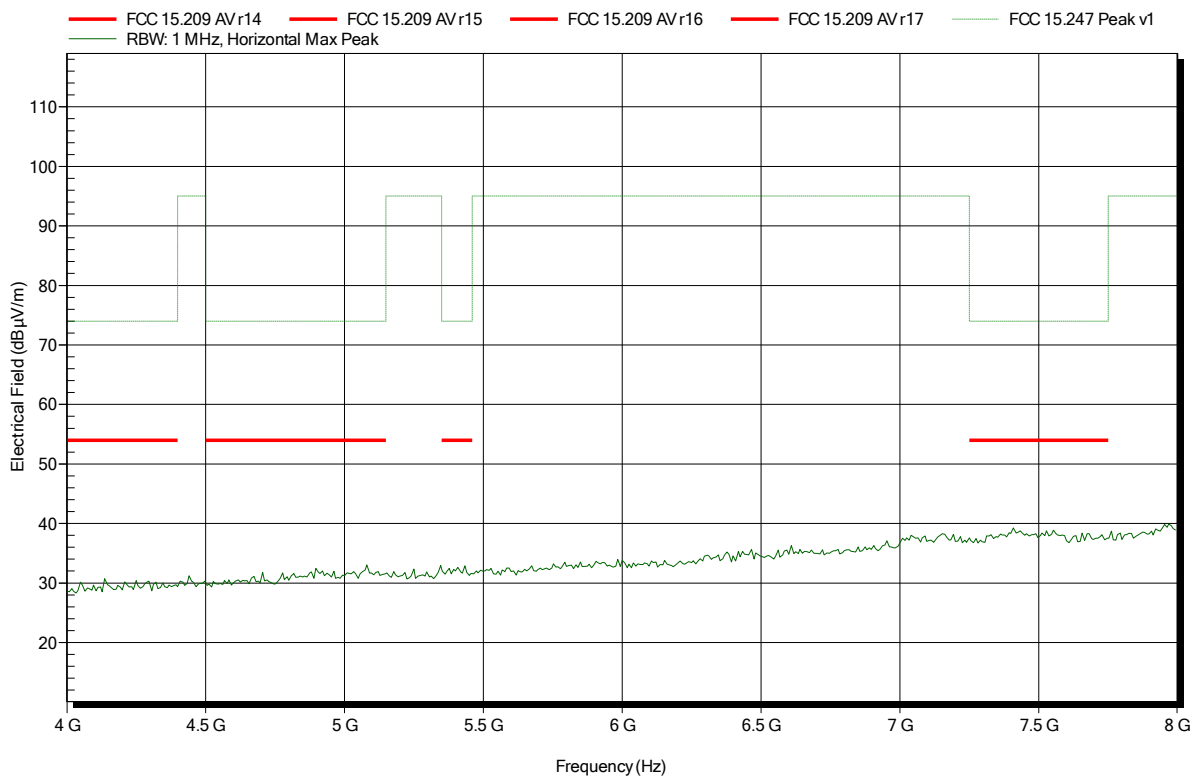

Spurious emissions according to FCC 15.247

Project number: G0M-1701-6190

Applicant: Kamstrup A/S
 EUT Name: READy Converter for US/Canada market
 Model: READy Converter
 Test Site: Eurofins Product Service GmbH
 Operator: Mr. Suckow
 Test Conditions: Tnom: 24°C, Vnom: 5.0 VDC
 Antenna: Schwarzbeck BBHA 9120D, Vertical
 Measurement distance: 3 m
 Mode: TX; SRD 912.5 MHz
 Test Date: 2017-02-14
 Note: Roof top antenna

Index 63

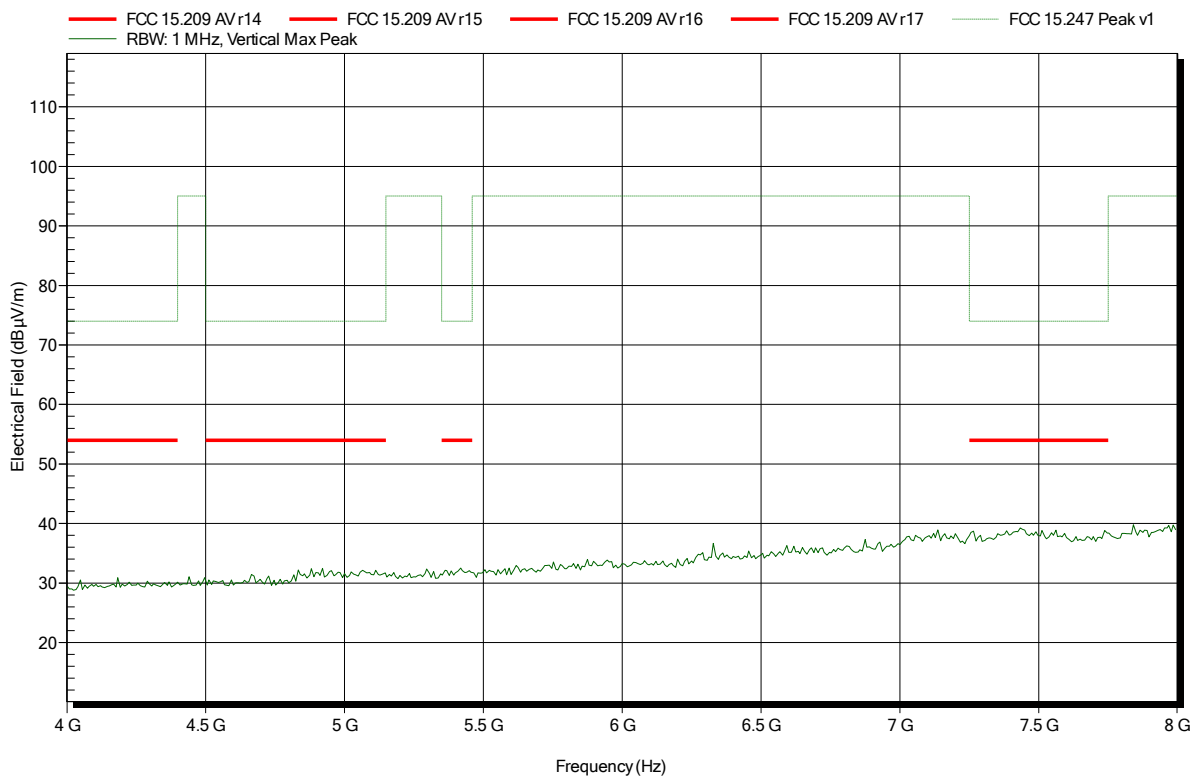

Spurious emissions according to FCC 15.247

Project number: G0M-1701-6190

Applicant: Kamstrup A/S
 EUT Name: READy Converter for US/Canada market
 Model: READy Converter
 Test Site: Eurofins Product Service GmbH
 Operator: Mr. Suckow
 Test Conditions: Tnom: 24°C, Vnom: 5.0 VDC
 Antenna: Schwarzbeck BBHA 9120D, Horizontal
 Measurement distance: 1 m converted to 3m
 Mode: TX; SRD 912.5 MHz
 Test Date: 2017-02-14
 Note: Roof top antenna

Index 67

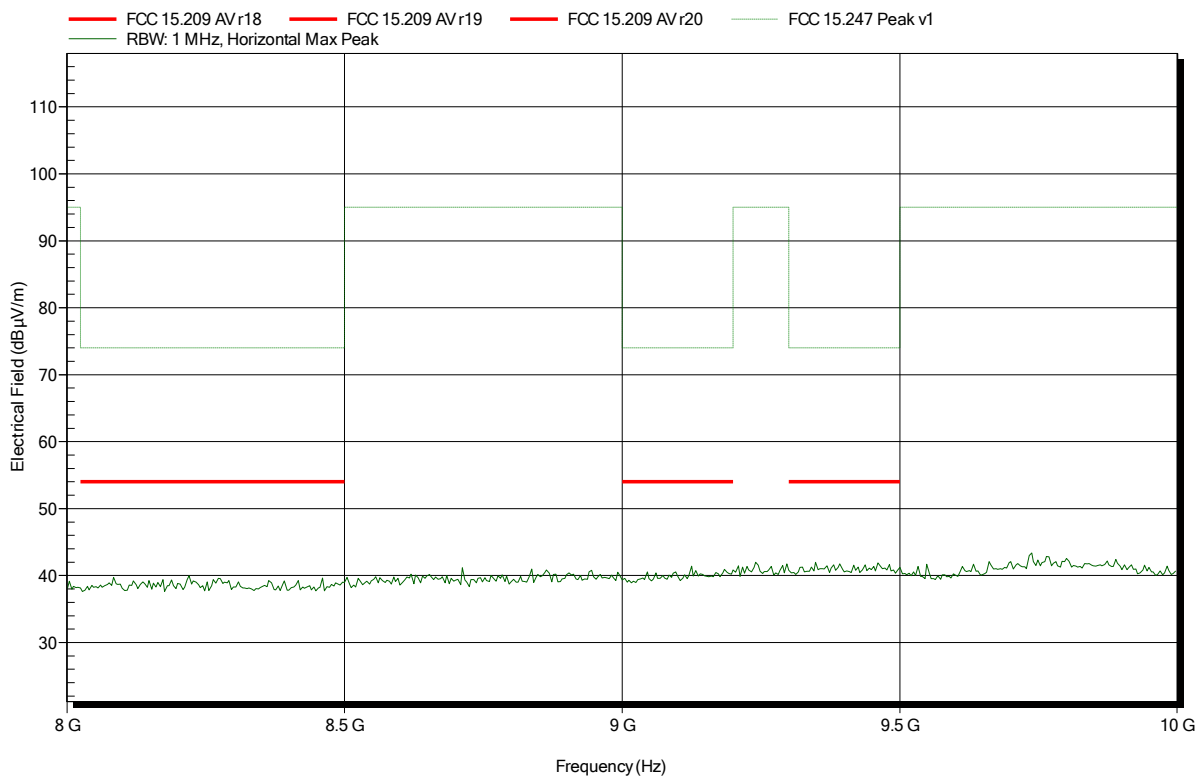

Spurious emissions according to FCC 15.247

Project number: G0M-1701-6190

Applicant: Kamstrup A/S
 EUT Name: READy Converter for US/Canada market
 Model: READy Converter
 Test Site: Eurofins Product Service GmbH
 Operator: Mr. Suckow
 Test Conditions: Tnom: 24°C, Vnom: 5.0 VDC
 Antenna: Schwarzbeck BBHA 9120D, Vertical
 Measurement distance: 1 m converted to 3m
 Mode: TX; SRD 912.5 MHz
 Test Date: 2017-02-14
 Note: Roof top antenna

Index 62

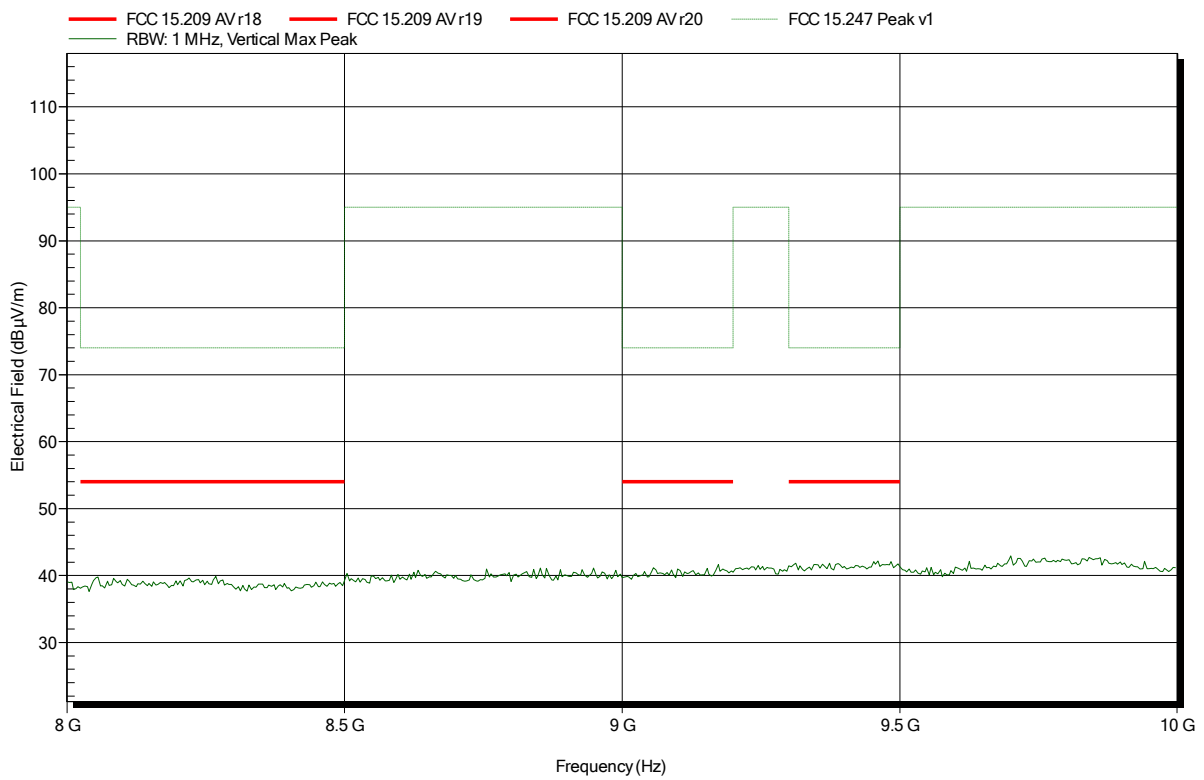

Spurious emissions according to FCC 15.247

Project number: G0M-1701-6190

Applicant: Kamstrup A/S
 EUT Name: READY Converter for US/Canada market
 Model: READY Converter
 Test Site: Eurofins Product Service GmbH
 Operator: Mr. Suckow
 Test Conditions: Tnom: 24°C, Vnom: 5.0 VDC
 Antenna: Schwarzbeck BBHA 9120D, Horizontal
 Measurement distance: 1 m converted to 3m
 Mode: TX; SRD 912.5 MHz
 Test Date: 2017-02-14
 Note: Roof top antenna

Index 68

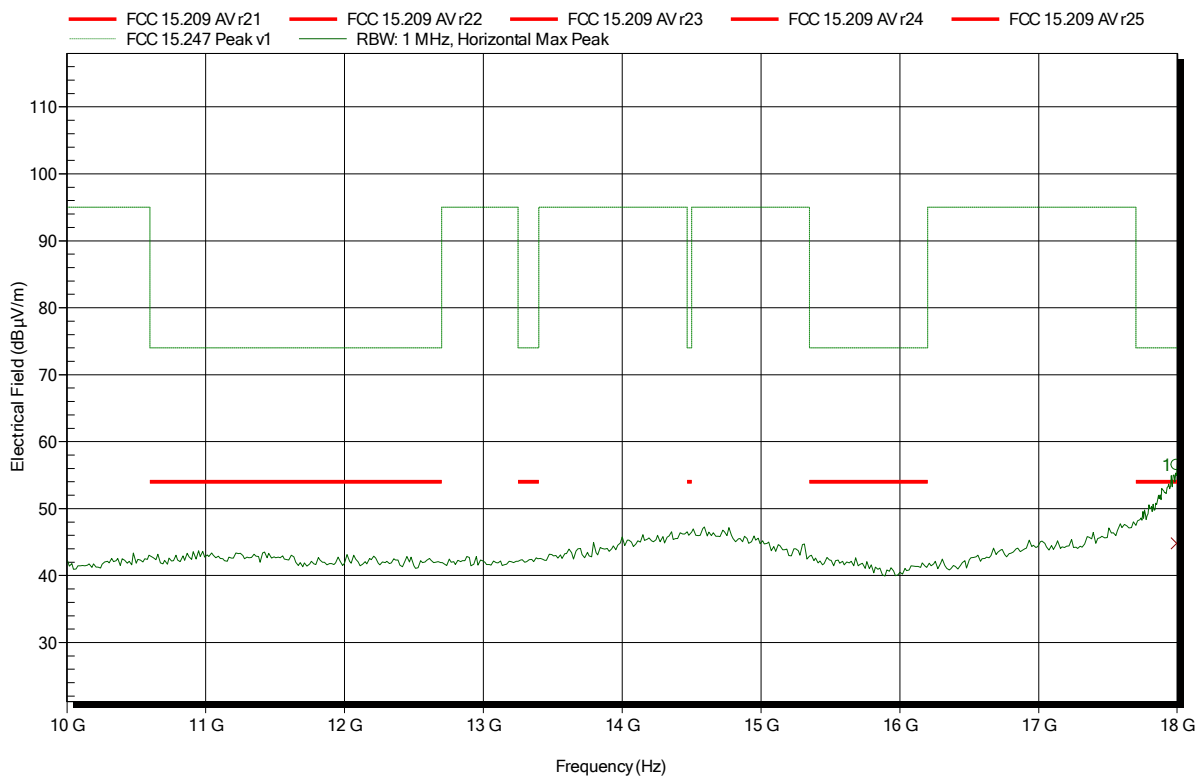

Frequency	Peak	Peak Limit	Peak Difference	Status
17.995 GHz	56.52 dBµV/m	74 dBµV/m	-17.48 dB	Pass
Frequency	Average	Average Limit	Average Difference	Average Status
17.995 GHz	44.82 dBµV/m	54 dBµV/m	-9.18 dB	Pass

Spurious emissions according to FCC 15.247

Project number: G0M-1701-6190

Applicant: Kamstrup A/S
 EUT Name: READY Converter for US/Canada market
 Model: READY Converter
 Test Site: Eurofins Product Service GmbH
 Operator: Mr. Suckow
 Test Conditions: Tnom: 24°C, Vnom: 5.0 VDC
 Antenna: Schwarzbeck BBHA 9120D, Vertical
 Measurement distance: 1 m converted to 3m
 Mode: TX; SRD 912.5 MHz
 Test Date: 2017-02-14
 Note: Roof top antenna

Index 61

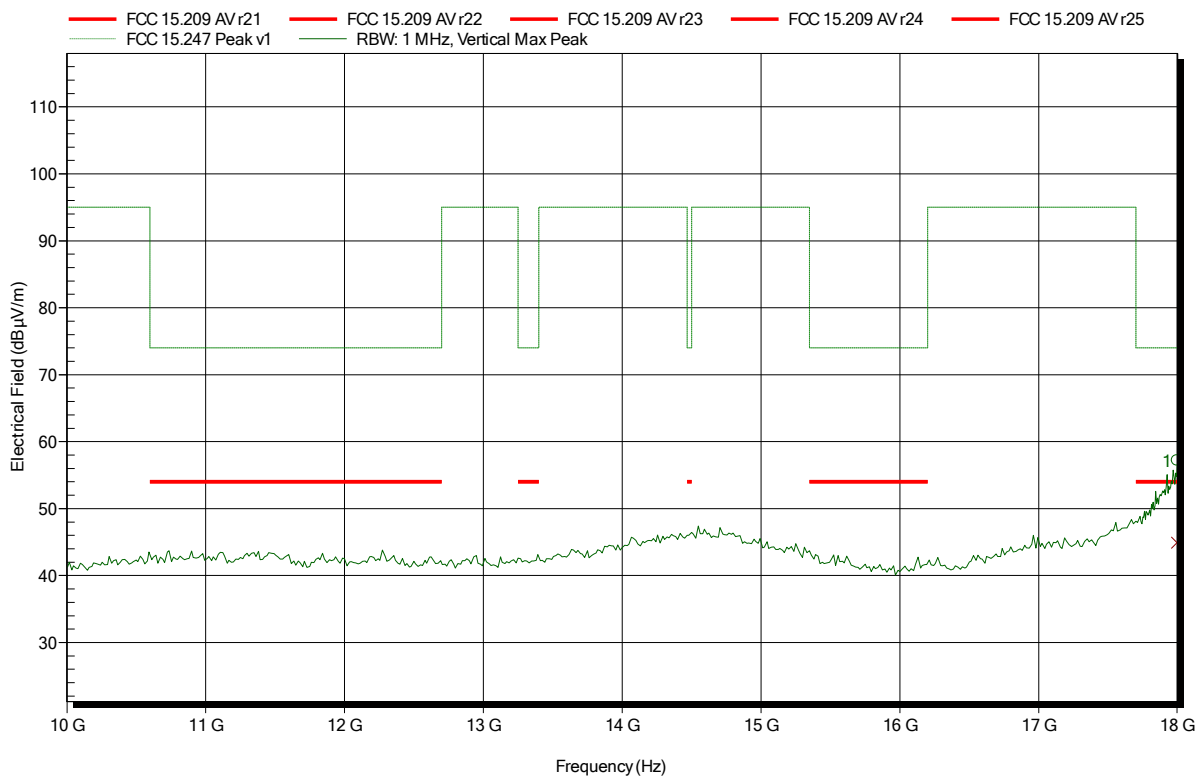

Frequency	Peak	Peak Limit	Peak Difference	Status
17.997 GHz	57.17 dBµV/m	74 dBµV/m	-16.83 dB	Pass
Frequency	Average	Average Limit	Average Difference	Average Status
17.997 GHz	44.91 dBµV/m	54 dBµV/m	-9.09 dB	Pass

Spurious emissions according to FCC 15.247

Project number: G0M-1701-6190

Applicant: Kamstrup A/S
 EUT Name: REAdy Converter for US/Canada market
 Model: REAdy Converter
 Test Site: Eurofins Product Service GmbH
 Operator: Mr. Suckow
 Test Conditions: Tnom: 24°C, Vnom: 5.0 VDC
 Antenna: Amplifier Research AT 4560, Horizontal
 Measurement distance: 1 m converted to 3m
 Mode: TX; SRD 912.5 MHz
 Test Date: 2017-02-14
 Note: Roof top antenna

Index 69

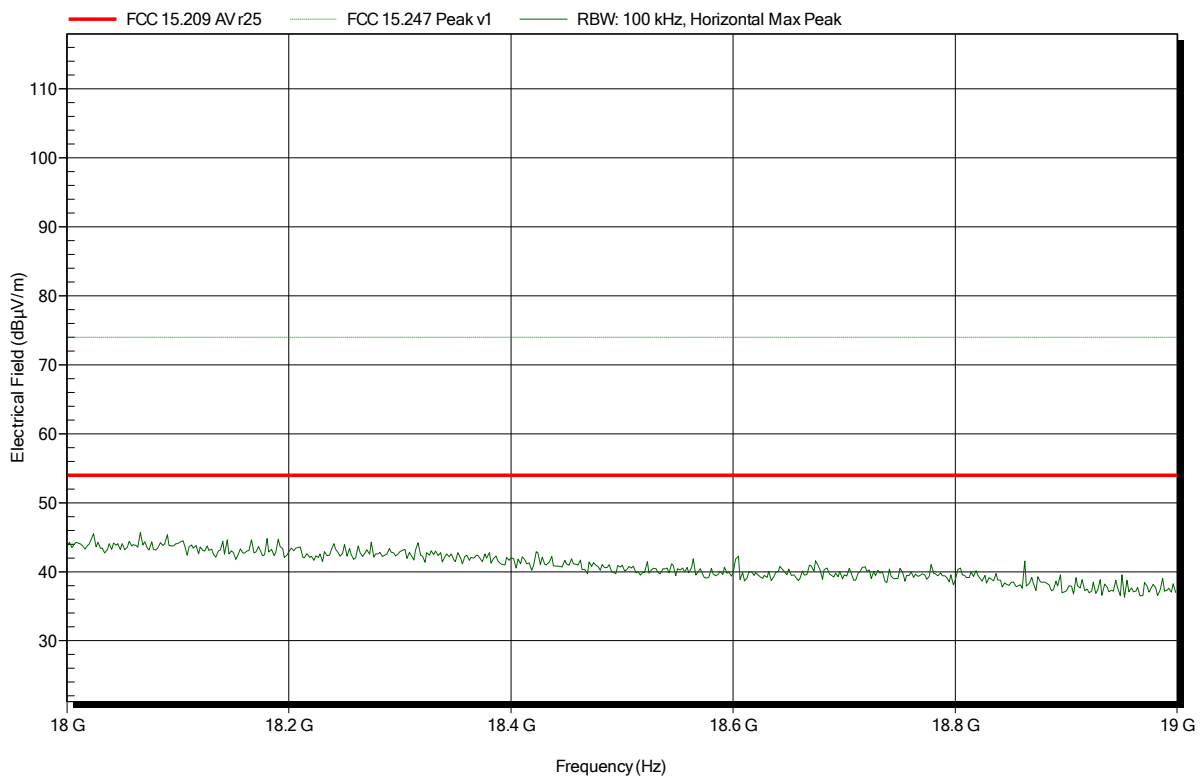

Spurious emissions according to FCC 15.247

Project number: G0M-1701-6190

Applicant: Kamstrup A/S
 EUT Name: READy Converter for US/Canada market
 Model: READy Converter
 Test Site: Eurofins Product Service GmbH
 Operator: Mr. Suckow
 Test Conditions: Tnom: 24°C, Vnom: 5.0 VDC
 Antenna: Amplifier Research AT 4560, Vertical
 Measurement distance: 1 m converted to 3m
 Mode: TX; SRD 912.5 MHz
 Test Date: 2017-02-14
 Note: Roof top antenna

Index 70

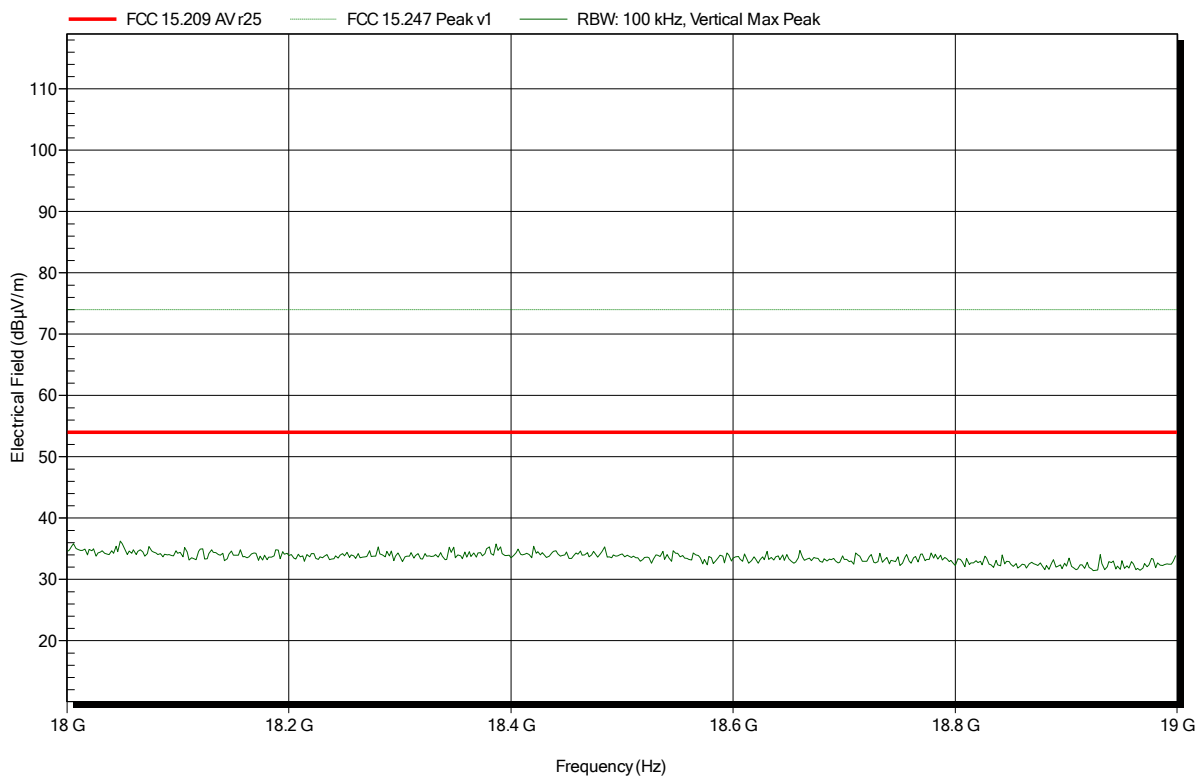

Spurious emissions according to FCC 15.247

Project number: G0M-1701-6190

Applicant: Kamstrup A/S
 EUT Name: READy Converter for US/Canada market
 Model: READy Converter
 Test Site: Eurofins Product Service GmbH
 Operator: Mr. Handrik
 Test Conditions: Tnom: 21°C, Vnom: 5V DC
 Antenna: Rohde & Schwarz HK 116, Horizontal
 Measurement distance: 3 m
 Mode: TX; TX 918.5 MHz
 Test Date: 2017-02-14
 Note: Roof top antenna

Index 28

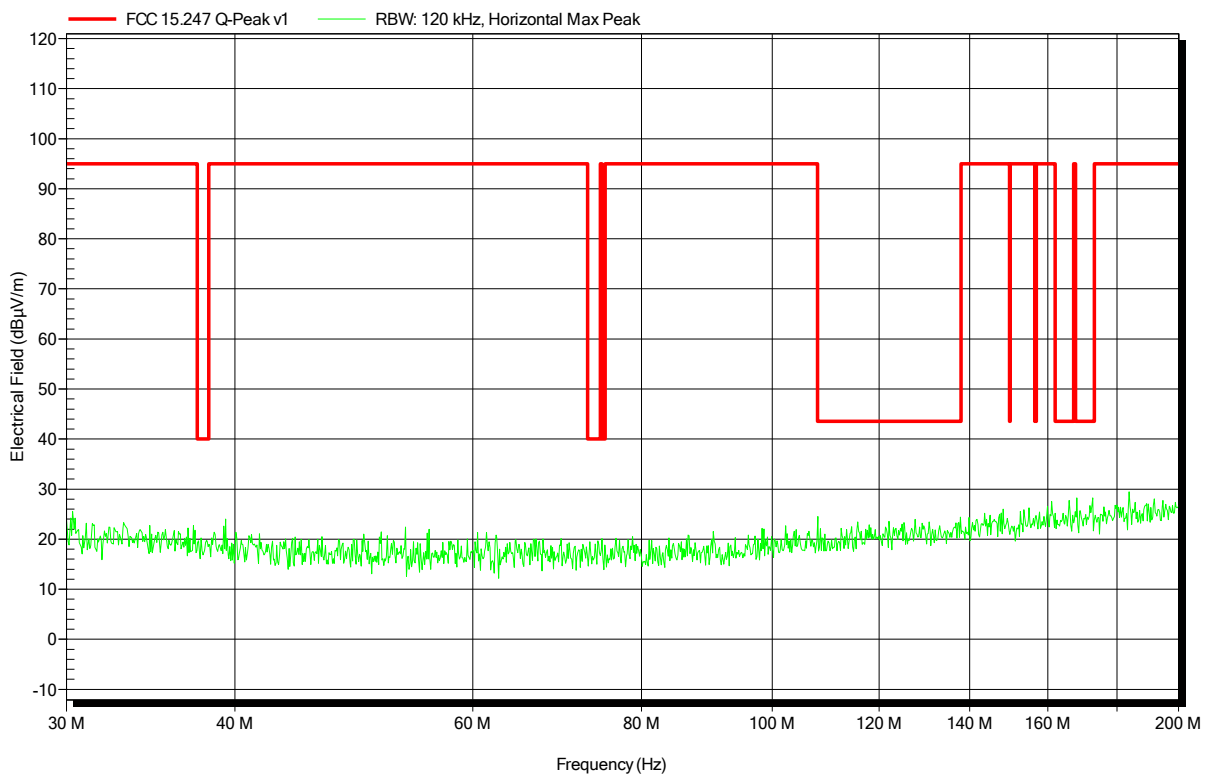

Spurious emissions according to FCC 15.247

Project number: G0M-1701-6190

Applicant: Kamstrup A/S
 EUT Name: READy Converter for US/Canada market
 Model: READy Converter
 Test Site: Eurofins Product Service GmbH
 Operator: Mr. Handrik
 Test Conditions: Tnom: 21°C, Vnom: 5V DC
 Antenna: Rohde & Schwarz HK 116, Vertical
 Measurement distance: 3 m
 Mode: TX; TX 918.5 MHz
 Test Date: 2017-02-14
 Note: Roof top antenna

Index 27

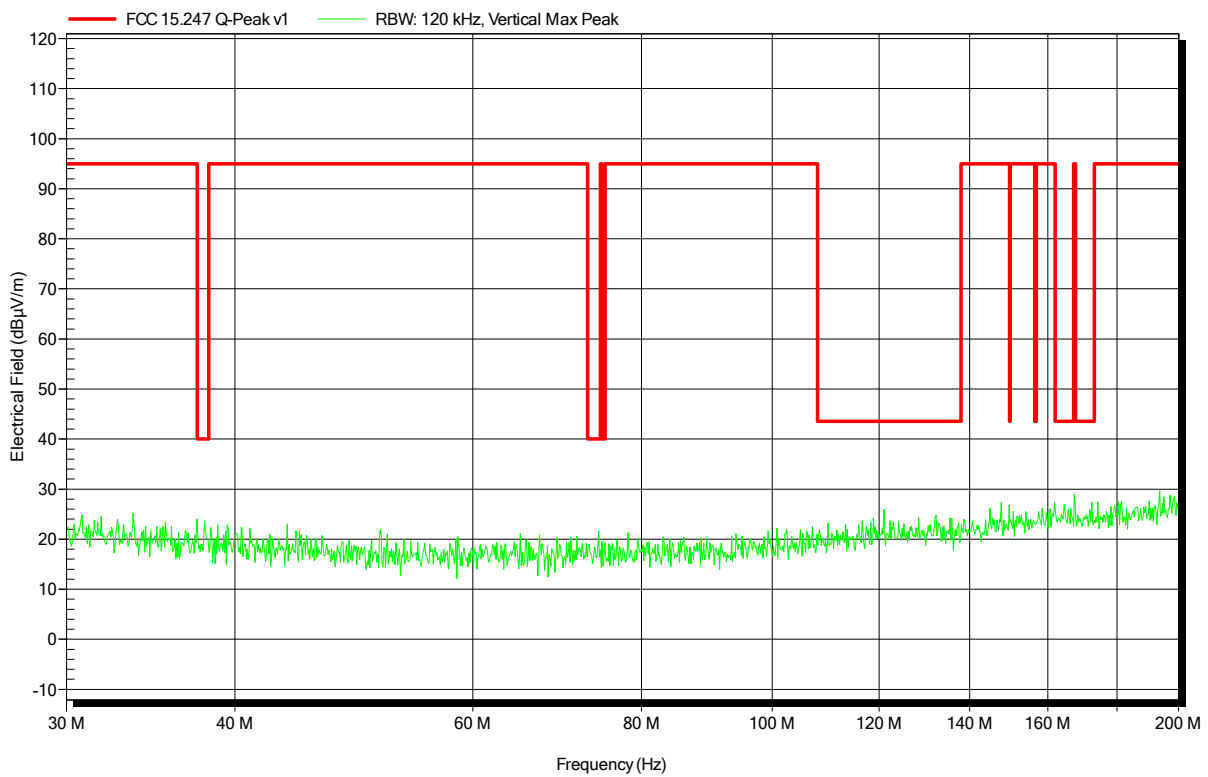

Spurious emissions according to FCC 15.247

Project number: G0M-1701-6190

Applicant:	Kamstrup A/S
EUT Name:	READy Converter for US/Canada market
Model:	READy Converter
Test Site:	Eurofins Product Service GmbH
Operator:	Mr. Handrik
Test Conditions:	Tnom: 21°C, Vnom: 5V DC
Antenna:	Rohde & Schwarz HL 223, Horizontal
Measurement distance:	3 m
Mode:	TX; TX 918.5 MHz
Test Date:	2017-02-14
Note:	Roof top antenna

Index 52

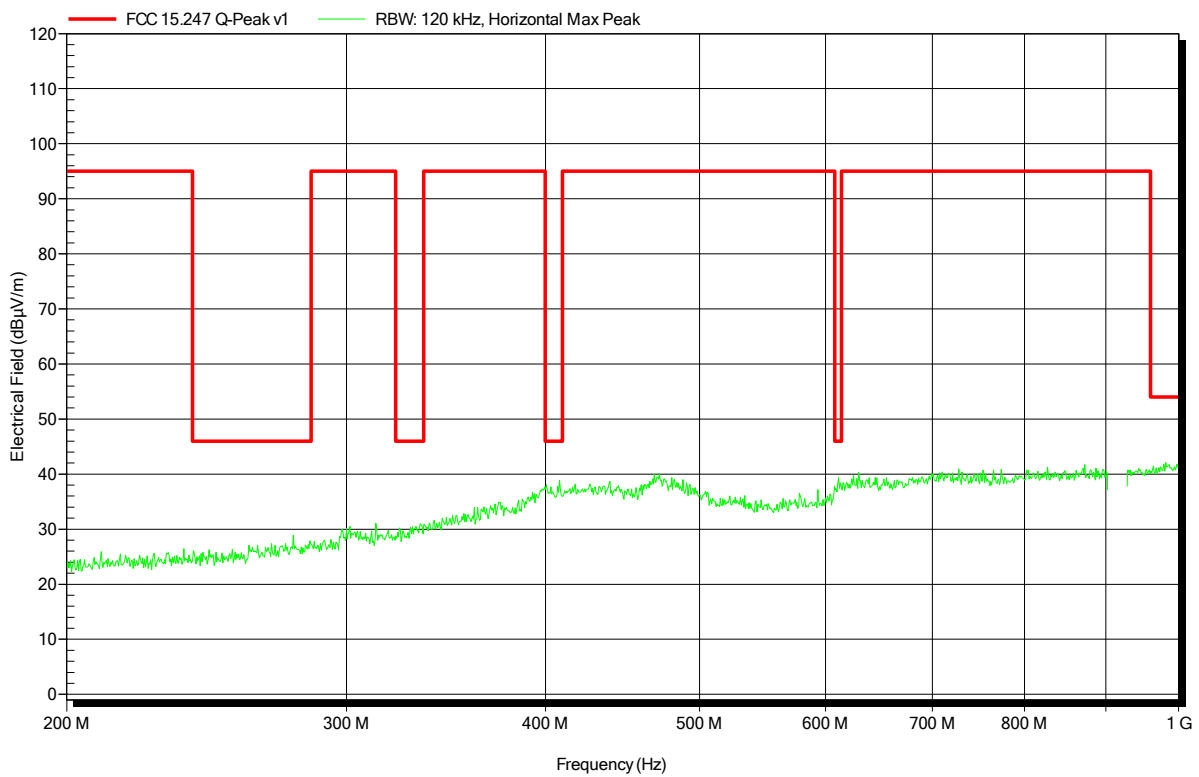

Spurious emissions according to FCC 15.247

Project number: G0M-1701-6190

Applicant: Kamstrup A/S
 EUT Name: READy Converter for US/Canada market
 Model: READy Converter
 Test Site: Eurofins Product Service GmbH
 Operator: Mr. Handrik
 Test Conditions: Tnom: 21°C, Vnom: 5V DC
 Antenna: Rohde & Schwarz HL 223, Vertical
 Measurement distance: 3 m
 Mode: TX; TX 918.5 MHz
 Test Date: 2017-02-14
 Note: Roof top antenna

Index 53

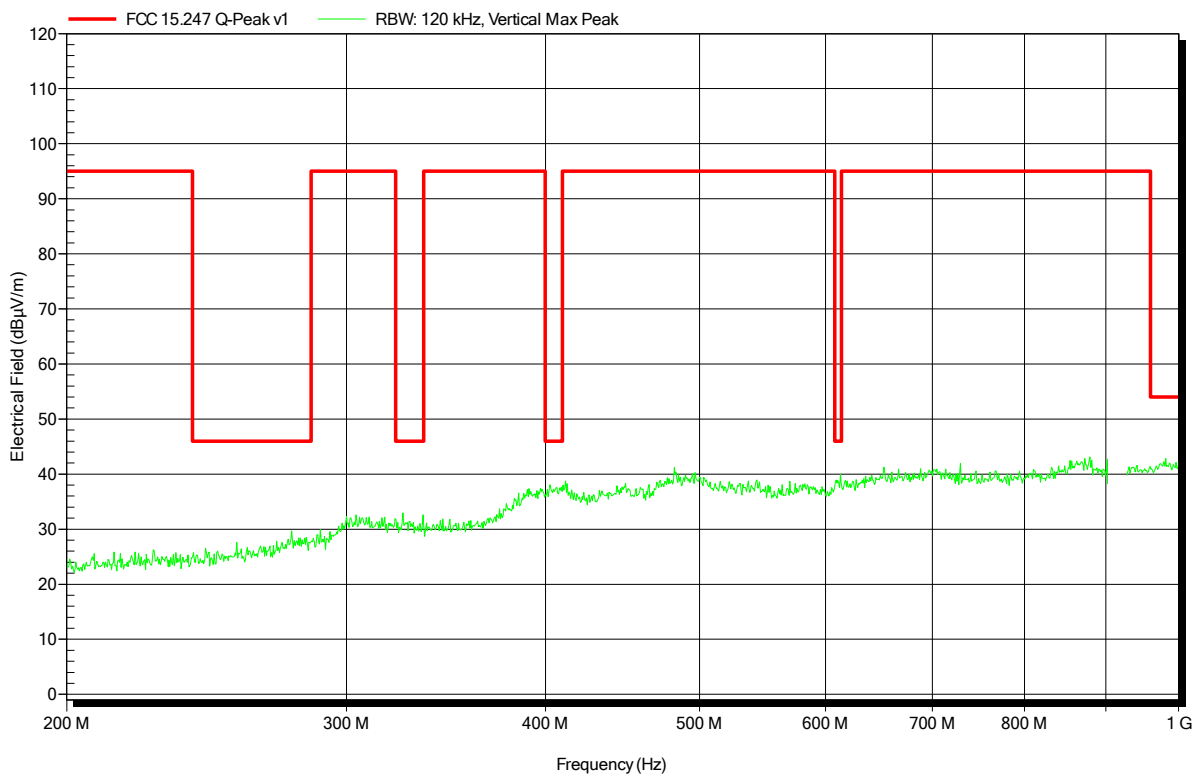

Spurious emissions according to FCC 15.247

Project number: G0M-1701-6190

Applicant: Kamstrup A/S
 EUT Name: READy Converter for US/Canada market
 Model: READy Converter
 Test Site: Eurofins Product Service GmbH
 Operator: Mr. Suckow
 Test Conditions: Tnom: 24°C, Vnom: 5.0 VDC
 Antenna: Rohde & Schwarz HL 223, Horizontal
 Measurement distance: 3 m
 Mode: TX; SRD 918.5 MHz
 Test Date: 2017-02-14
 Note: band-edge

Index 23

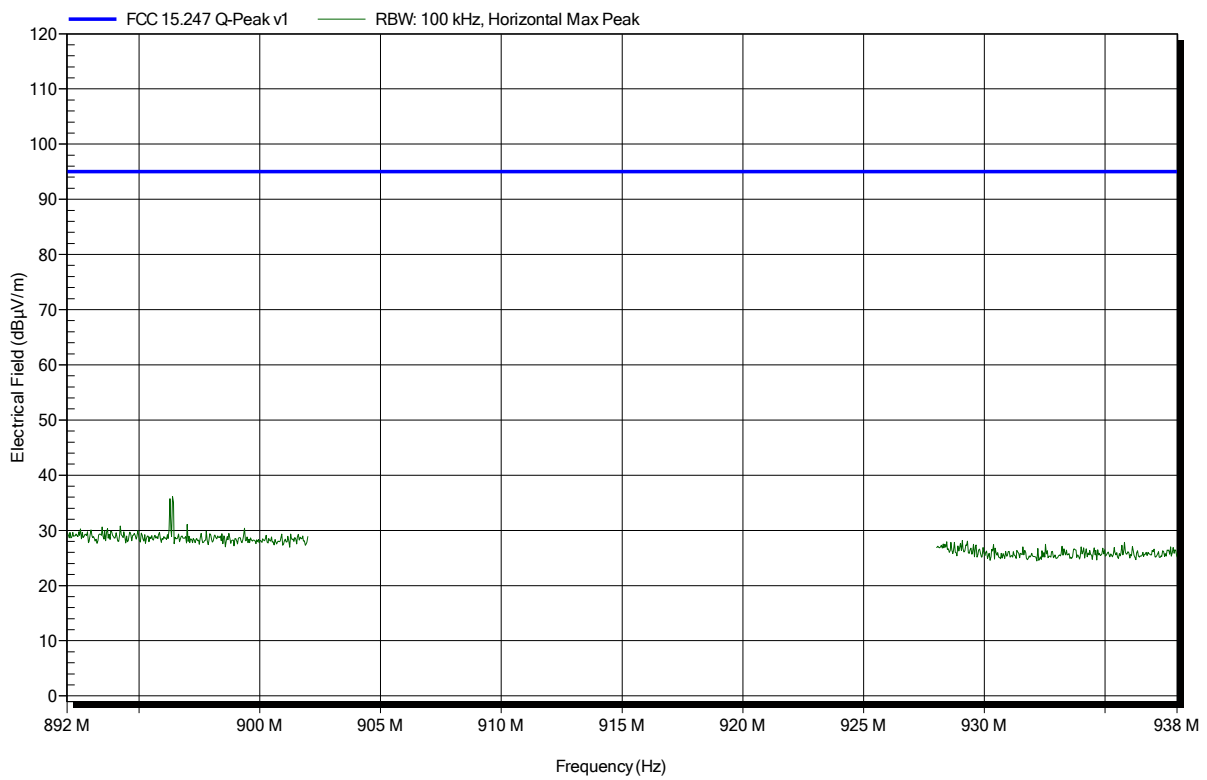

Spurious emissions according to FCC 15.247

Project number: G0M-1701-6190

Applicant: Kamstrup A/S
 EUT Name: READy Converter for US/Canada market
 Model: READy Converter
 Test Site: Eurofins Product Service GmbH
 Operator: Mr. Suckow
 Test Conditions: Tnom: 24°C, Vnom: 5.0 VDC
 Antenna: Rohde & Schwarz HL 223, Vertical
 Measurement distance: 3 m
 Mode: TX; SRD 918.5 MHz
 Test Date: 2017-02-14
 Note: band-edge

Index 22

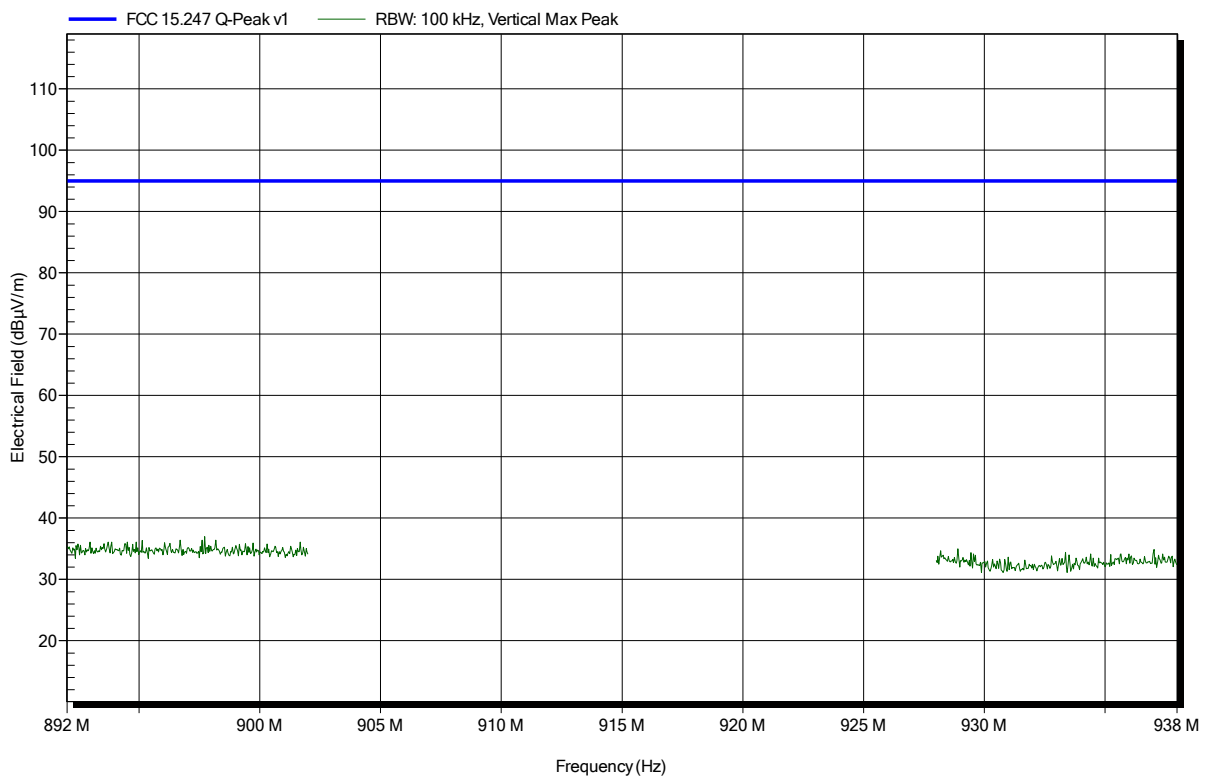

Spurious emissions according to FCC 15.247

Project number: G0M-1701-6190

Applicant: Kamstrup A/S
 EUT Name: READy Converter for US/Canada market
 Model: READy Converter
 Test Site: Eurofins Product Service GmbH
 Operator: Mr. Suckow
 Test Conditions: Tnom: 24°C, Vnom: 5.0 VDC
 Antenna: Schwarzbeck BBHA 9120D, Horizontal
 Measurement distance: 1 m
 Mode: TX; SRD 918.5 MHz
 Test Date: 2017-02-14
 Note: Roof top antenna

Index 39

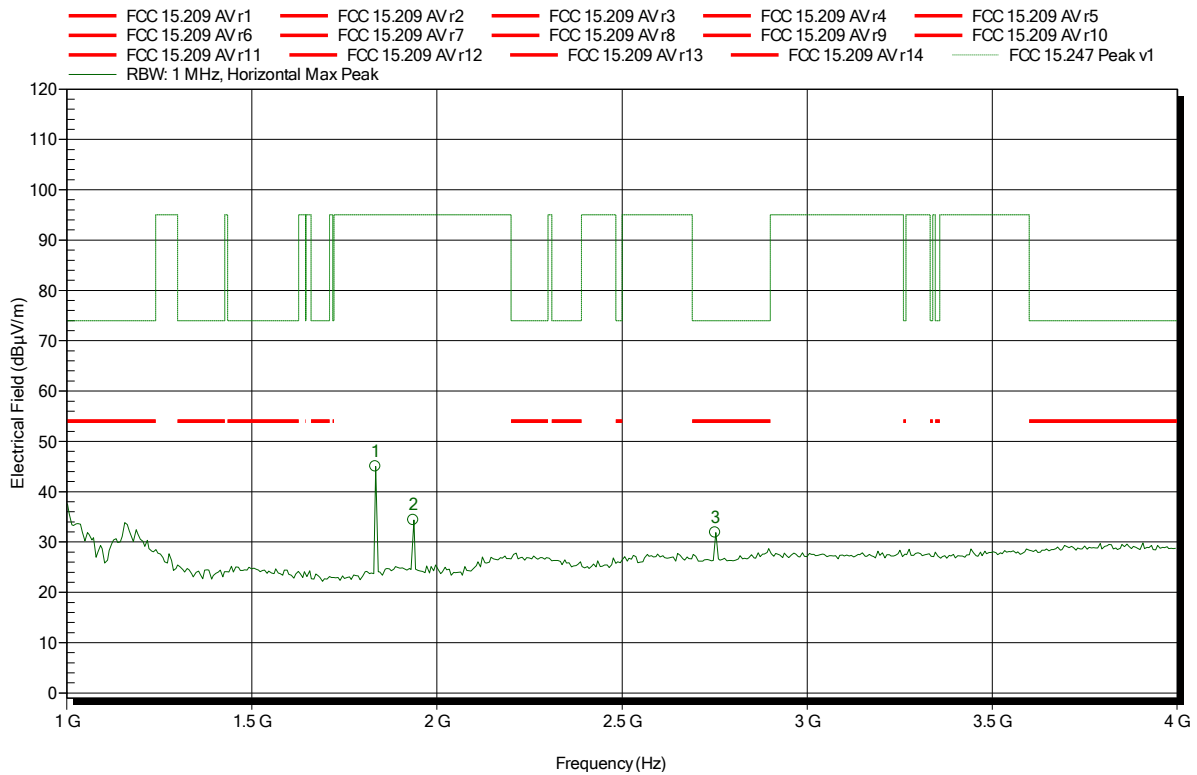

Frequency	Peak	Peak Limit	Peak Difference	Peak Status
1.834 GHz	45.03 dBµV/m	95 dBµV/m	-49.97 dB	Pass
1.936 GHz	34.4 dBµV/m	95 dBµV/m	-60.6 dB	Pass
2.752 GHz	31.88 dBµV/m	74 dBµV/m	-42.12 dB	Pass

Spurious emissions according to FCC 15.247

Project number: G0M-1701-6190

Applicant: Kamstrup A/S
 EUT Name: READY Converter for US/Canada market
 Model: READY Converter
 Test Site: Eurofins Product Service GmbH
 Operator: Mr. Suckow
 Test Conditions: Tnom: 24°C, Vnom: 5.0 VDC
 Antenna: Schwarzbeck BBHA 9120D, Vertical
 Measurement distance: 3 m
 Mode: TX; SRD 918.5 MHz
 Test Date: 2017-02-14
 Note: Roof top antenna

Index 44

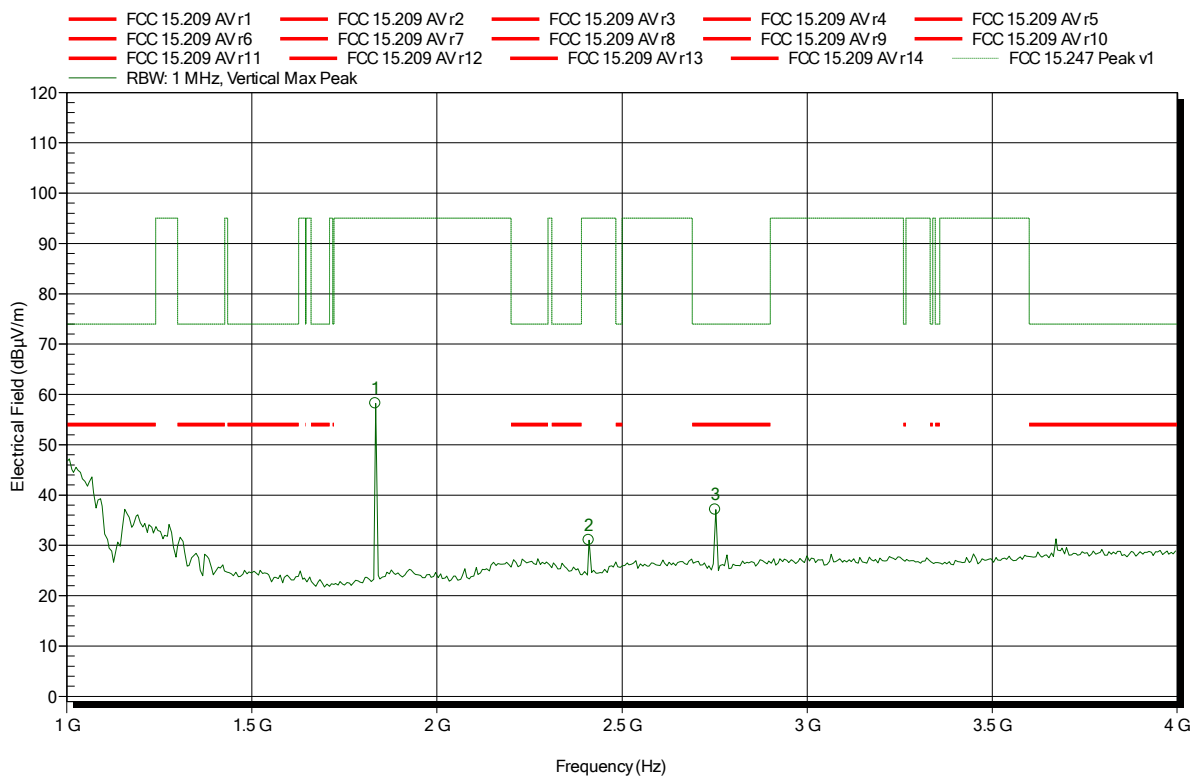

Frequency	Peak	Peak Limit	Peak Difference	Peak Status
1.834 GHz	58.25 dBµV/m	95 dBµV/m	-36.75 dB	Pass
2.41 GHz	31.07 dBµV/m	95 dBµV/m	-63.93 dB	Pass
2.752 GHz	37.11 dBµV/m	74 dBµV/m	-36.89 dB	Pass

Spurious emissions according to FCC 15.247

Project number: G0M-1701-6190

Applicant: Kamstrup A/S
 EUT Name: READY Converter for US/Canada market
 Model: READY Converter
 Test Site: Eurofins Product Service GmbH
 Operator: Mr. Suckow
 Test Conditions: Tnom: 24°C, Vnom: 5.0 VDC
 Antenna: Schwarzbeck BBHA 9120D, Horizontal
 Measurement distance: 1 m
 Mode: TX; SRD 918.5 MHz
 Test Date: 2017-02-14
 Note: Roof top antenna

Index 40

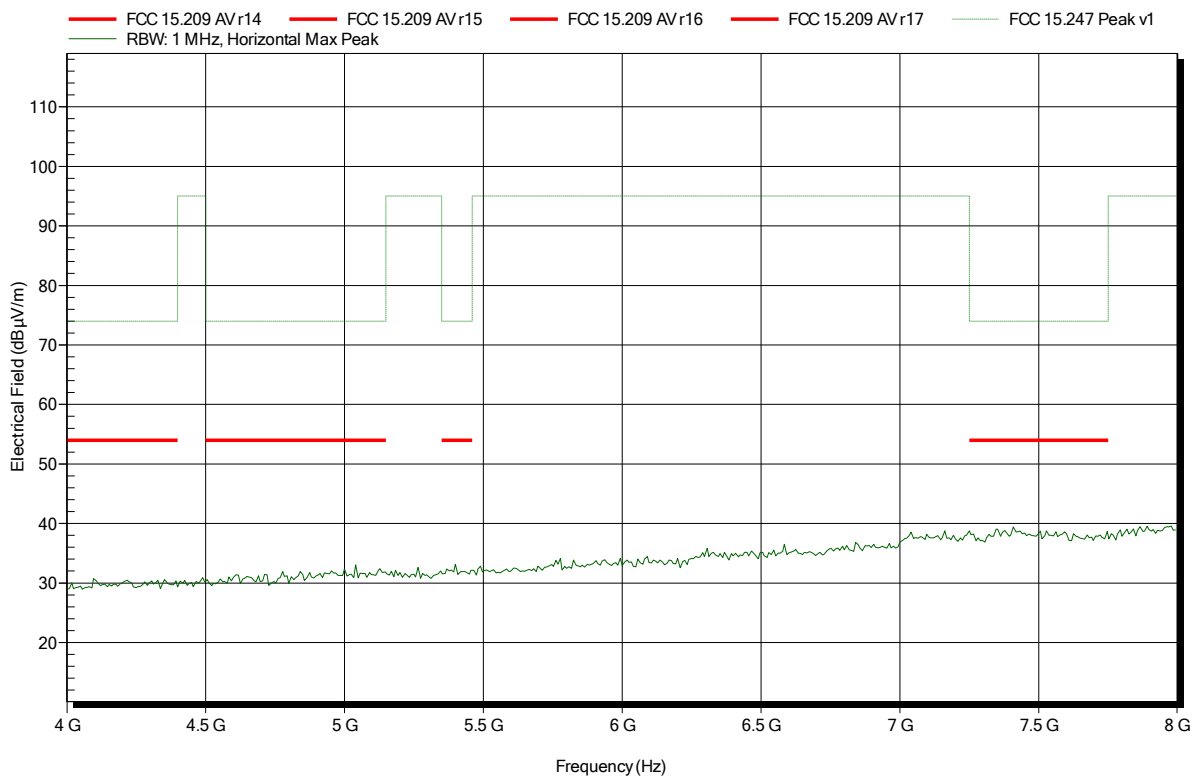

Spurious emissions according to FCC 15.247

Project number: G0M-1701-6190

Applicant: Kamstrup A/S
 EUT Name: READy Converter for US/Canada market
 Model: READy Converter
 Test Site: Eurofins Product Service GmbH
 Operator: Mr. Suckow
 Test Conditions: Tnom: 24°C, Vnom: 5.0 VDC
 Antenna: Schwarzbeck BBHA 9120D, Vertical
 Measurement distance: 3 m
 Mode: TX; SRD 918.5 MHz
 Test Date: 2017-02-14
 Note: Roof top antenna

Index 43

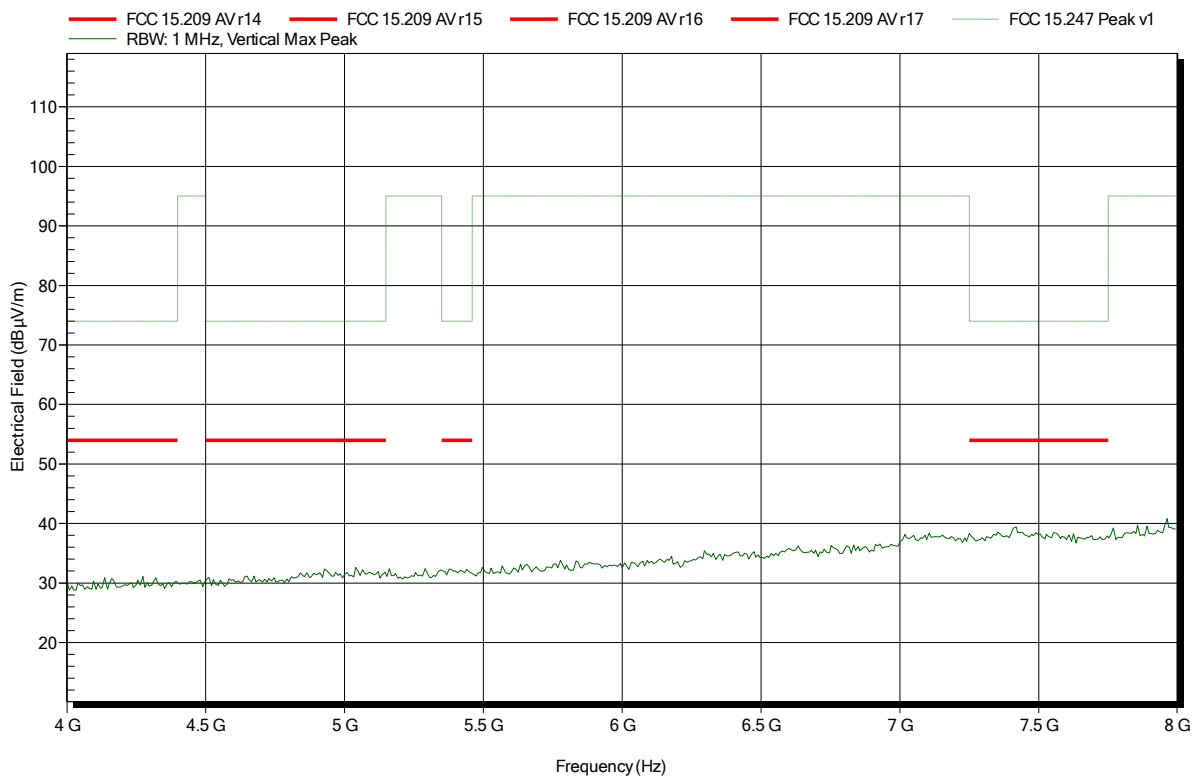

Spurious emissions according to FCC 15.247

Project number: G0M-1701-6190

Applicant: Kamstrup A/S
 EUT Name: READy Converter for US/Canada market
 Model: READy Converter
 Test Site: Eurofins Product Service GmbH
 Operator: Mr. Suckow
 Test Conditions: Tnom: 24°C, Vnom: 5.0 VDC
 Antenna: Schwarzbeck BBHA 9120D, Horizontal
 Measurement distance: 1 m converted to 3m
 Mode: TX; SRD 918.5 MHz
 Test Date: 2017-02-14
 Note: Roof top antenna

Index 41

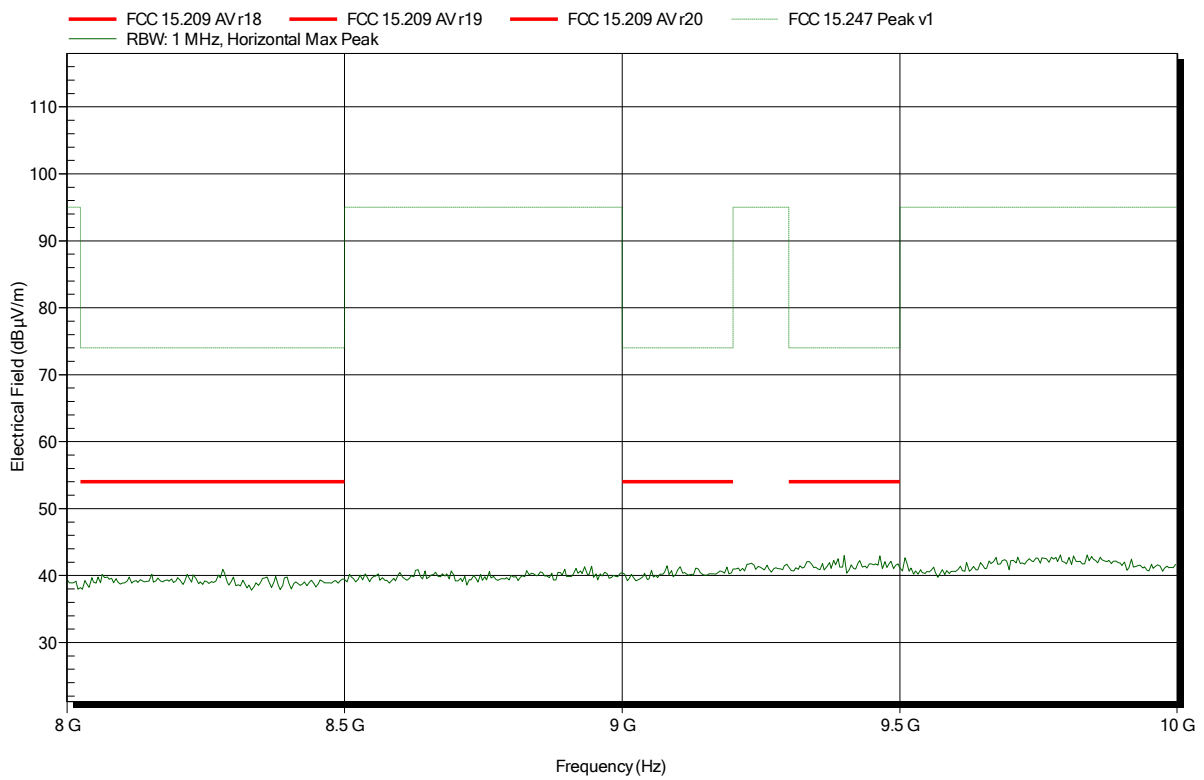

Spurious emissions according to FCC 15.247

Project number: G0M-1701-6190

Applicant: Kamstrup A/S
 EUT Name: READy Converter for US/Canada market
 Model: READy Converter
 Test Site: Eurofins Product Service GmbH
 Operator: Mr. Suckow
 Test Conditions: Tnom: 24°C, Vnom: 5.0 VDC
 Antenna: Schwarzbeck BBHA 9120D, Vertical
 Measurement distance: 1 m converted to 3m
 Mode: TX; SRD 918.5 MHz
 Test Date: 2017-02-14
 Note: Roof top antenna

Index 42

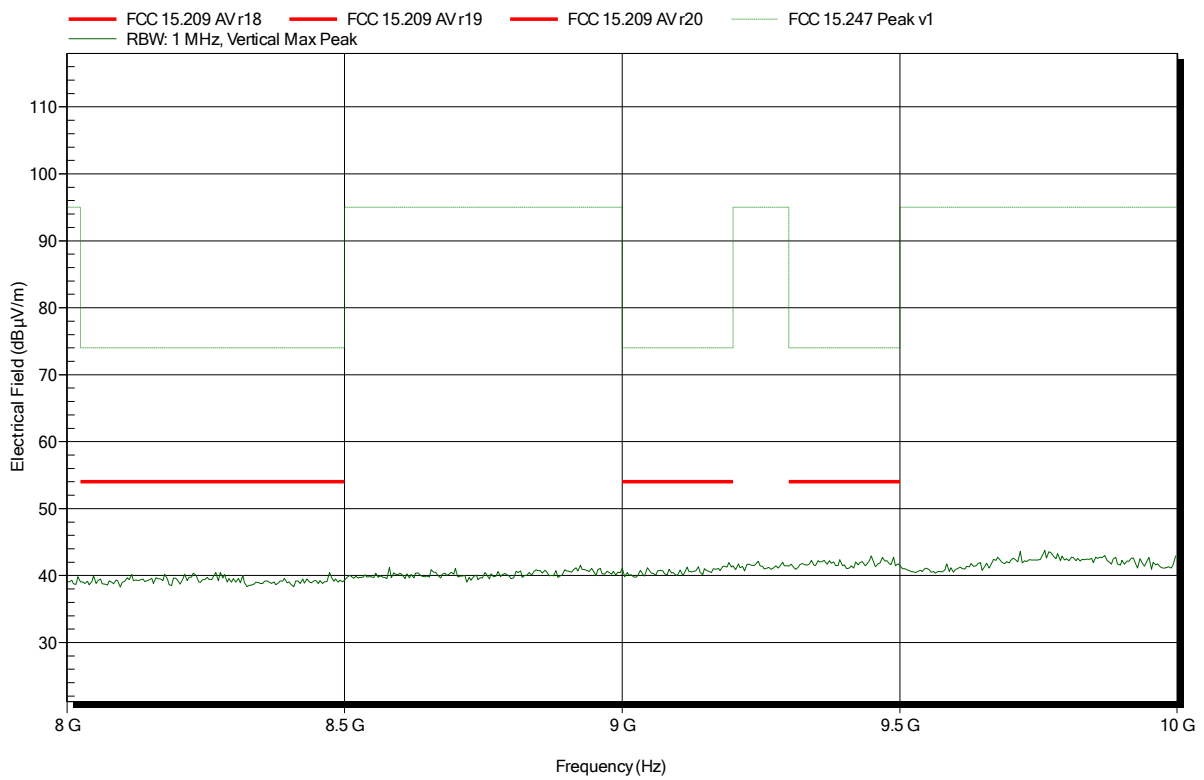

Spurious emissions according to FCC 15.247

Project number: G0M-1701-6190

Applicant: Kamstrup A/S
 EUT Name: READy Converter for US/Canada market
 Model: READy Converter
 Test Site: Eurofins Product Service GmbH
 Operator: Mr. Suckow
 Test Conditions: Tnom: 24°C, Vnom: 5.0 VDC
 Antenna: Schwarzbeck BBHA 9120D, Horizontal
 Measurement distance: 1 m converted to 3m
 Mode: TX; SRD 918.5 MHz
 Test Date: 2017-02-14
 Note: Roof top antenna

Index 51

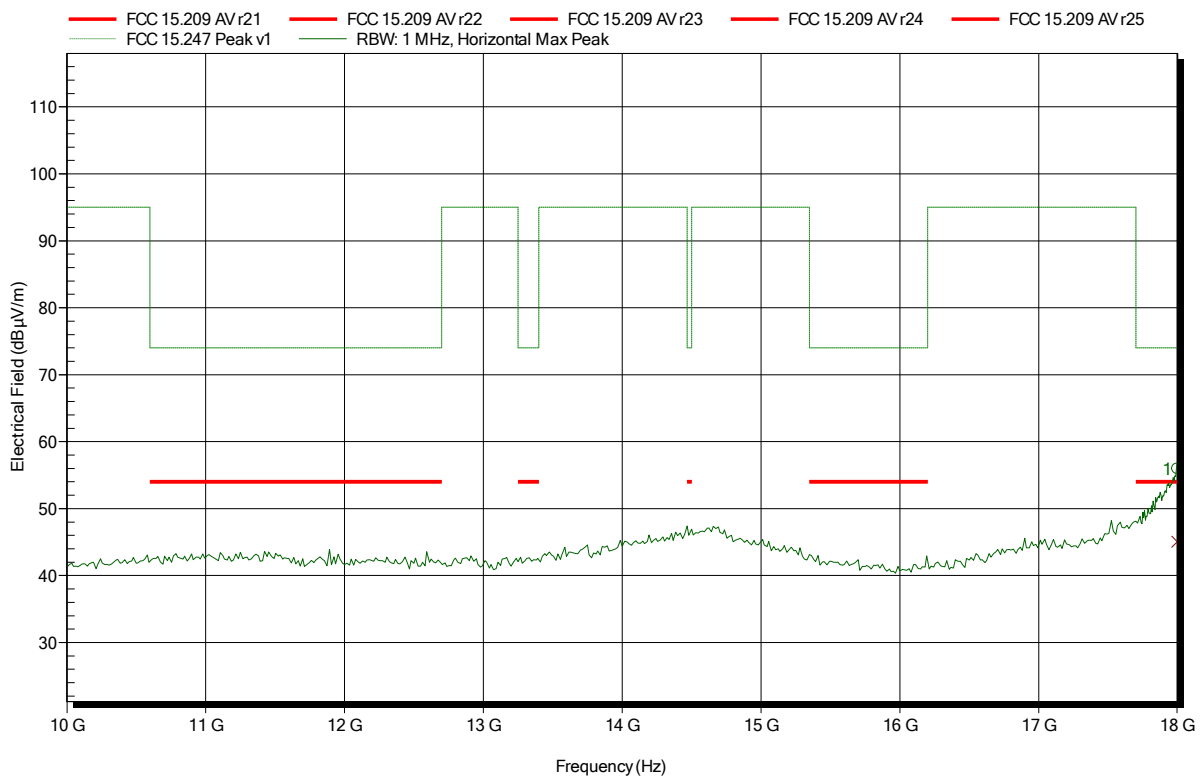

Frequency	Peak	Peak Limit	Peak Difference	Status
17.999 GHz	55.93 dBµV/m	74 dBµV/m	-18.07 dB	Pass
Frequency	Average	Average Limit	Average Difference	Average Status
17.999 GHz	45.07 dBµV/m	54 dBµV/m	-8.93 dB	Pass

Spurious emissions according to FCC 15.247

Project number: G0M-1701-6190

Applicant: Kamstrup A/S
 EUT Name: READy Converter for US/Canada market
 Model: READy Converter
 Test Site: Eurofins Product Service GmbH
 Operator: Mr. Suckow
 Test Conditions: Tnom: 24°C, Vnom: 5.0 VDC
 Antenna: Schwarzbeck BBHA 9120D, Vertical
 Measurement distance: 1 m converted to 3m
 Mode: TX; SRD 918.5 MHz
 Test Date: 2017-02-14
 Note: Roof top antenna

Index 50

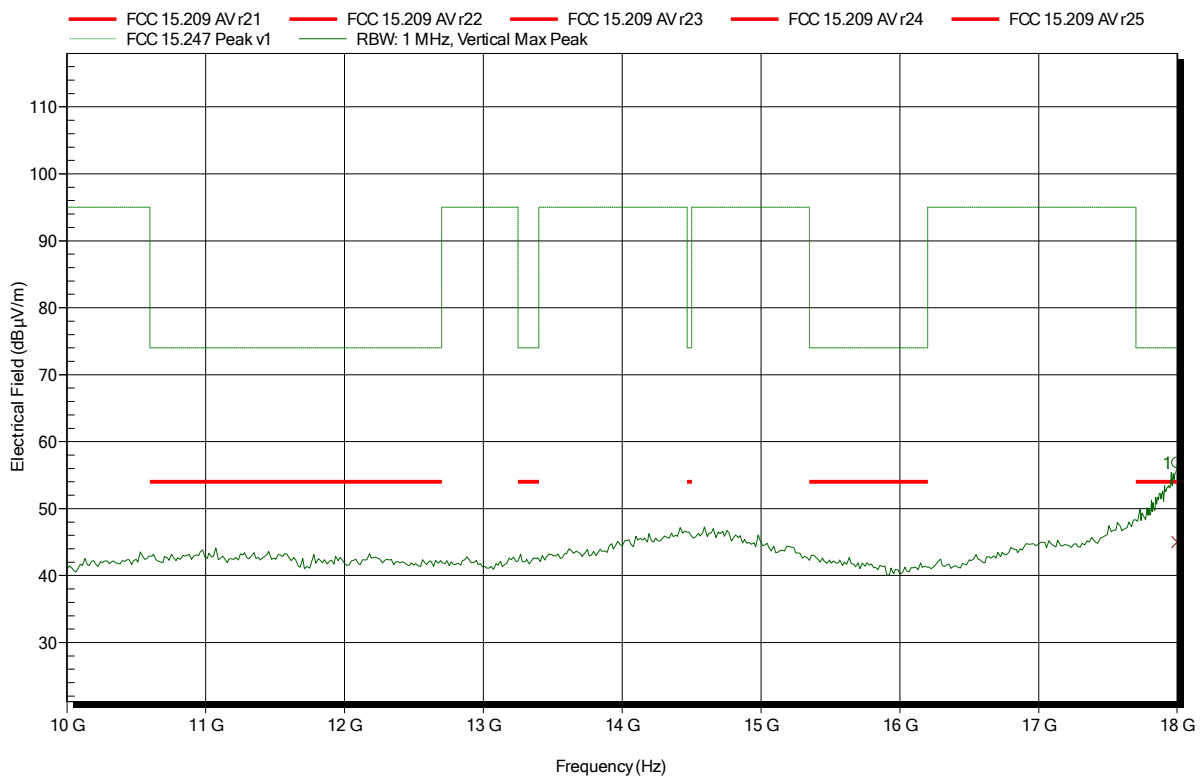

Frequency	Peak	Peak Limit	Peak Difference	Status
17.999 GHz	56.8 dBµV/m	74 dBµV/m	-17.2 dB	Pass
Frequency	Average	Average Limit	Average Difference	Average Status
17.999 GHz	44.98 dBµV/m	54 dBµV/m	-9.02 dB	Pass

Spurious emissions according to FCC 15.247

Project number: G0M-1701-6190

Applicant: Kamstrup A/S
 EUT Name: READy Converter for US/Canada market
 Model: READy Converter
 Test Site: Eurofins Product Service GmbH
 Operator: Mr. Suckow
 Test Conditions: Tnom: 24°C, Vnom: 5.0 VDC
 Antenna: Amplifier Research AT 4560, Horizontal
 Measurement distance: 1 m converted to 3m
 Mode: TX; SRD 918.5 MHz
 Test Date: 2017-02-14
 Note: Roof top antenna

Index 73

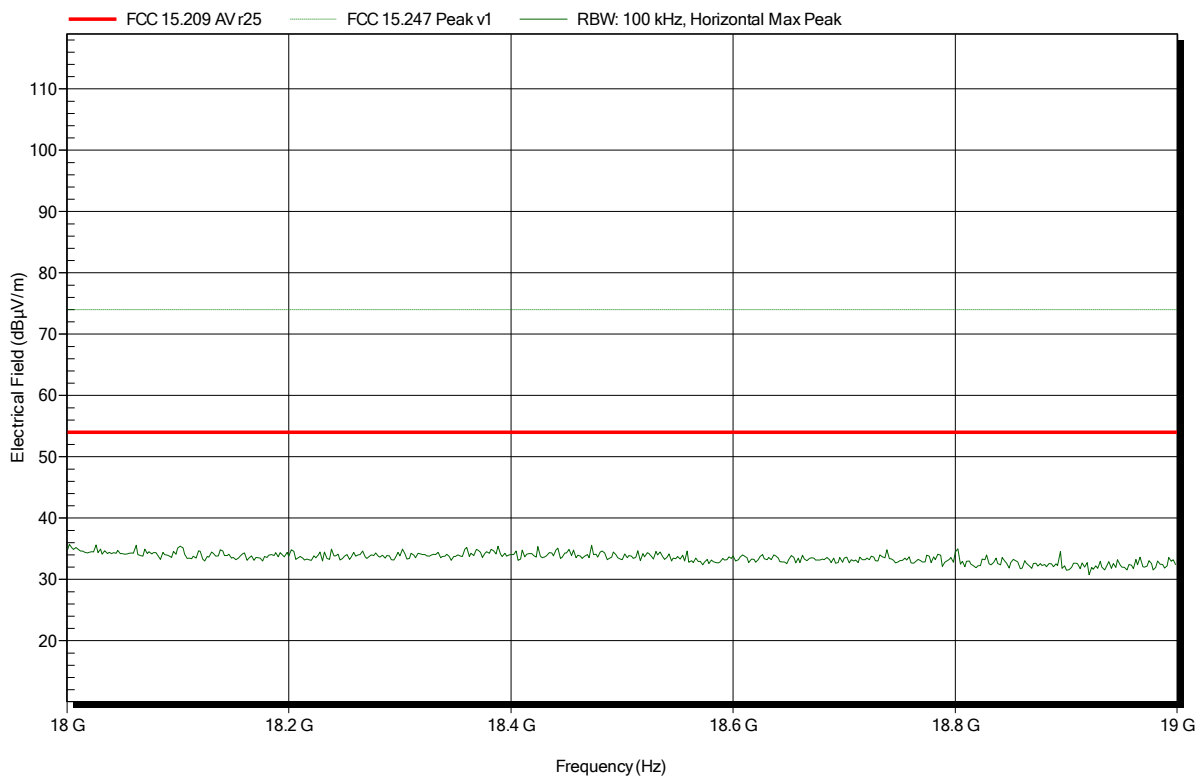

Spurious emissions according to FCC 15.247

Project number: G0M-1701-6190

Applicant: Kamstrup A/S
 EUT Name: READy Converter for US/Canada market
 Model: READy Converter
 Test Site: Eurofins Product Service GmbH
 Operator: Mr. Suckow
 Test Conditions: Tnom: 24°C, Vnom: 5.0 VDC
 Antenna: Amplifier Research AT 4560, Vertical
 Measurement distance: 1 m converted to 3m
 Mode: TX; SRD 918.5 MHz
 Test Date: 2017-02-14
 Note: Roof top antenna

Index 74

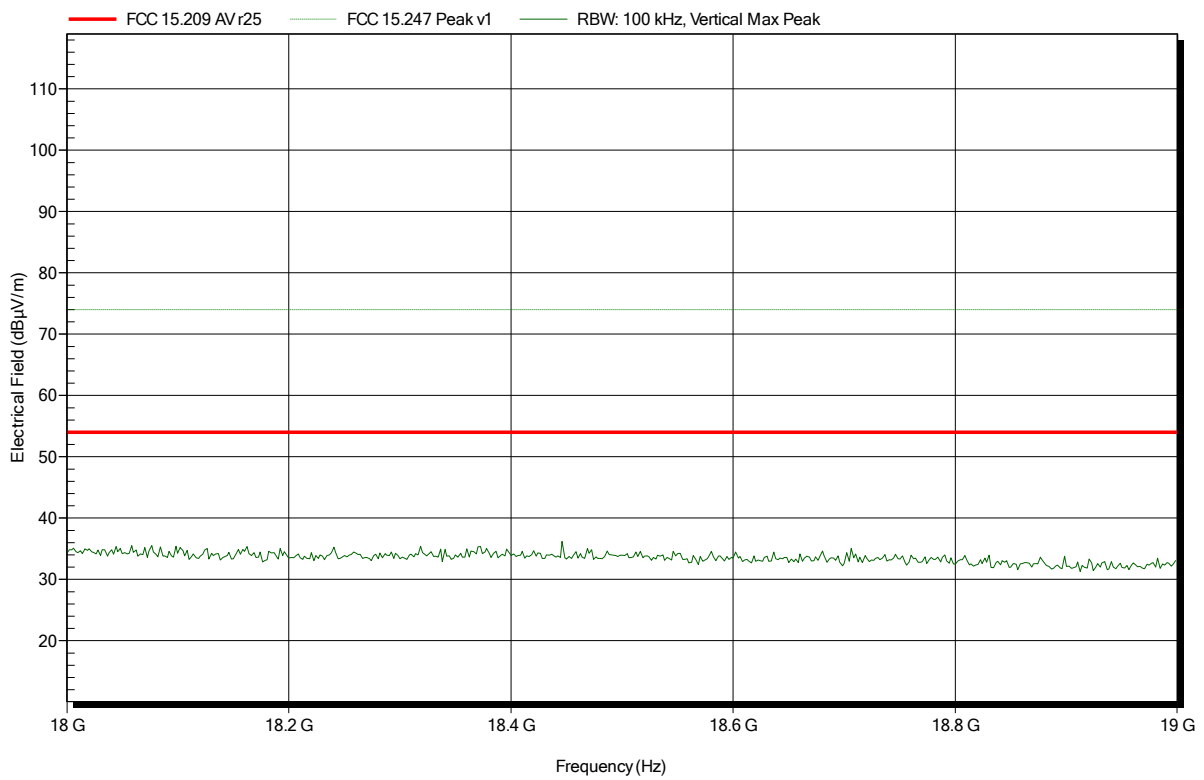

Spurious emissions according to FCC 15.247

Project number: G0M-1701-6190

Applicant: Kamstrup A/S
 EUT Name: READY Converter for US/Canada market
 Model: READY Converter
 Test Site: Eurofins Product Service GmbH
 Operator: Mr. Suckow
 Test Conditions: Tnom: 24°C, Vnom: 5.0 VDC
 Antenna: Schwarzbeck BBHA 9120D, Horizontal
 Measurement distance: 1 m
 Mode: TX; SRD 912.5 MHz
 Test Date: 2017-02-14
 Note: Whip antenna

Index 79

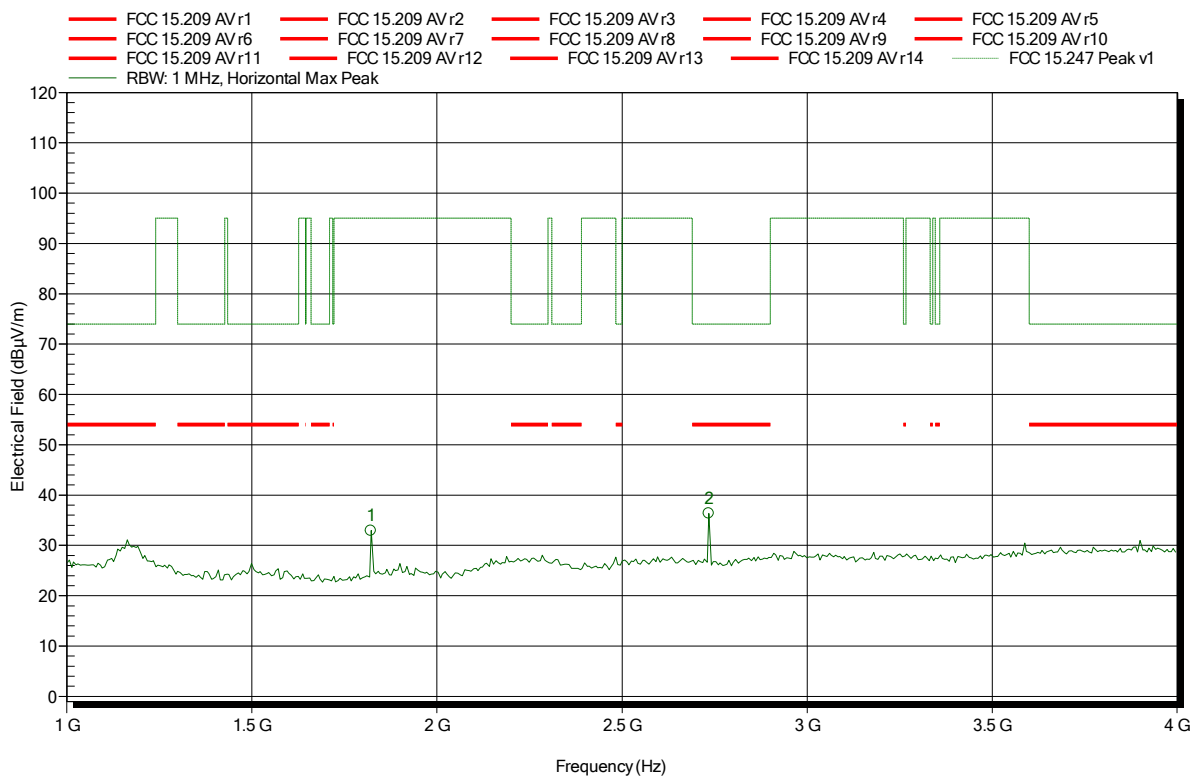

Frequency	Peak	Peak Limit	Peak Difference	Peak Status
1.822 GHz	32.93 dBµV/m	95 dBµV/m	-62.07 dB	Pass
2.734 GHz	36.35 dBµV/m	74 dBµV/m	-37.65 dB	Pass

Spurious emissions according to FCC 15.247

Project number: G0M-1701-6190

Applicant: Kamstrup A/S
 EUT Name: READY Converter for US/Canada market
 Model: READY Converter
 Test Site: Eurofins Product Service GmbH
 Operator: Mr. Suckow
 Test Conditions: Tnom: 24°C, Vnom: 5.0 VDC
 Antenna: Schwarzbeck BBHA 9120D, Vertical
 Measurement distance: 3 m
 Mode: TX; SRD 912.5 MHz
 Test Date: 2017-02-14
 Note: Whip antenna

Index 80

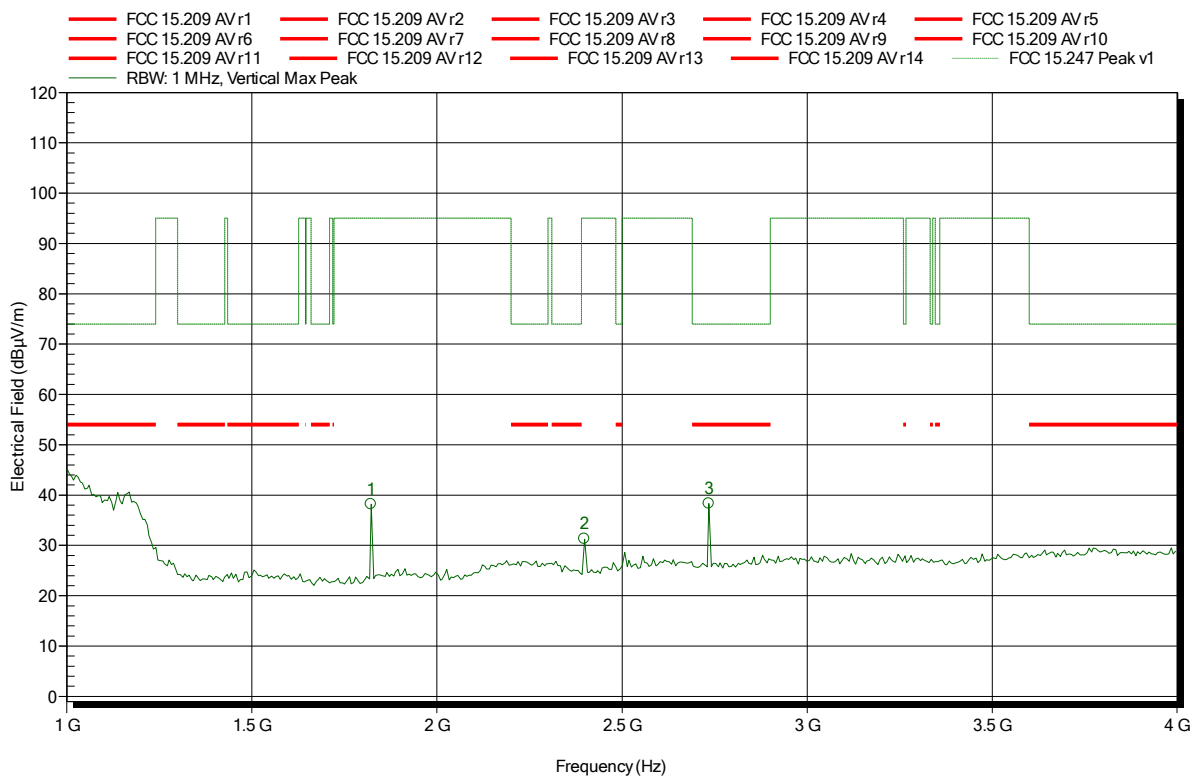

Frequency	Peak	Peak Limit	Peak Difference	Peak Status
1.822 GHz	38.18 dBµV/m	95 dBµV/m	-56.82 dB	Pass
2.398 GHz	31.29 dBµV/m	95 dBµV/m	-63.71 dB	Pass
2.734 GHz	38.31 dBµV/m	74 dBµV/m	-35.69 dB	Pass

Spurious emissions according to FCC 15.247

Project number: G0M-1701-6190

Applicant: Kamstrup A/S
 EUT Name: READY Converter for US/Canada market
 Model: READY Converter
 Test Site: Eurofins Product Service GmbH
 Operator: Mr. Suckow
 Test Conditions: Tnom: 24°C, Vnom: 5.0 VDC
 Antenna: Schwarzbeck BBHA 9120D, Horizontal
 Measurement distance: 1 m
 Mode: TX; SRD 918.5 MHz
 Test Date: 2017-02-14
 Note: Whip antenna

Index 75

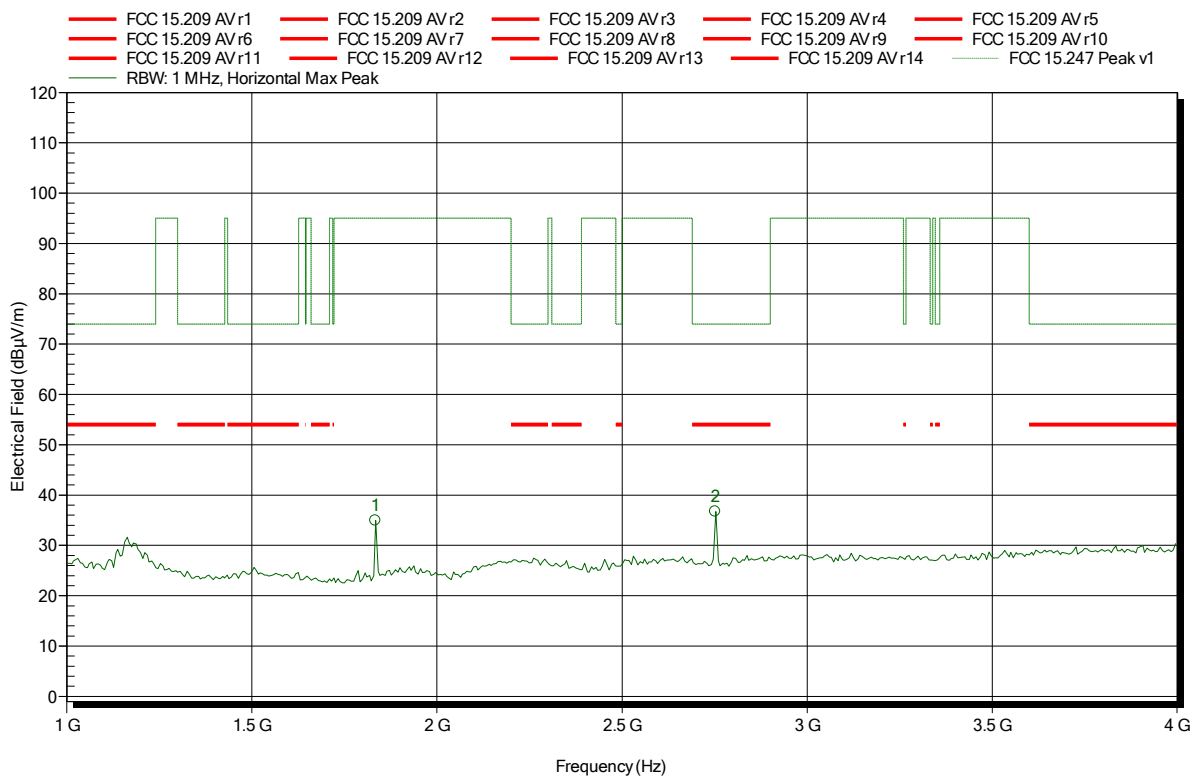

Frequency	Peak	Peak Limit	Peak Difference	Peak Status
1.834 GHz	34.93 dBµV/m	95 dBµV/m	-60.07 dB	Pass
2.752 GHz	36.72 dBµV/m	74 dBµV/m	-37.28 dB	Pass

Spurious emissions according to FCC 15.247

Project number: G0M-1701-6190

Applicant: Kamstrup A/S
 EUT Name: READY Converter for US/Canada market
 Model: READY Converter
 Test Site: Eurofins Product Service GmbH
 Operator: Mr. Suckow
 Test Conditions: Tnom: 24°C, Vnom: 5.0 VDC
 Antenna: Schwarzbeck BBHA 9120D, Vertical
 Measurement distance: 3 m
 Mode: TX; SRD 918.5 MHz
 Test Date: 2017-02-14
 Note: Whip antenna

Index 76

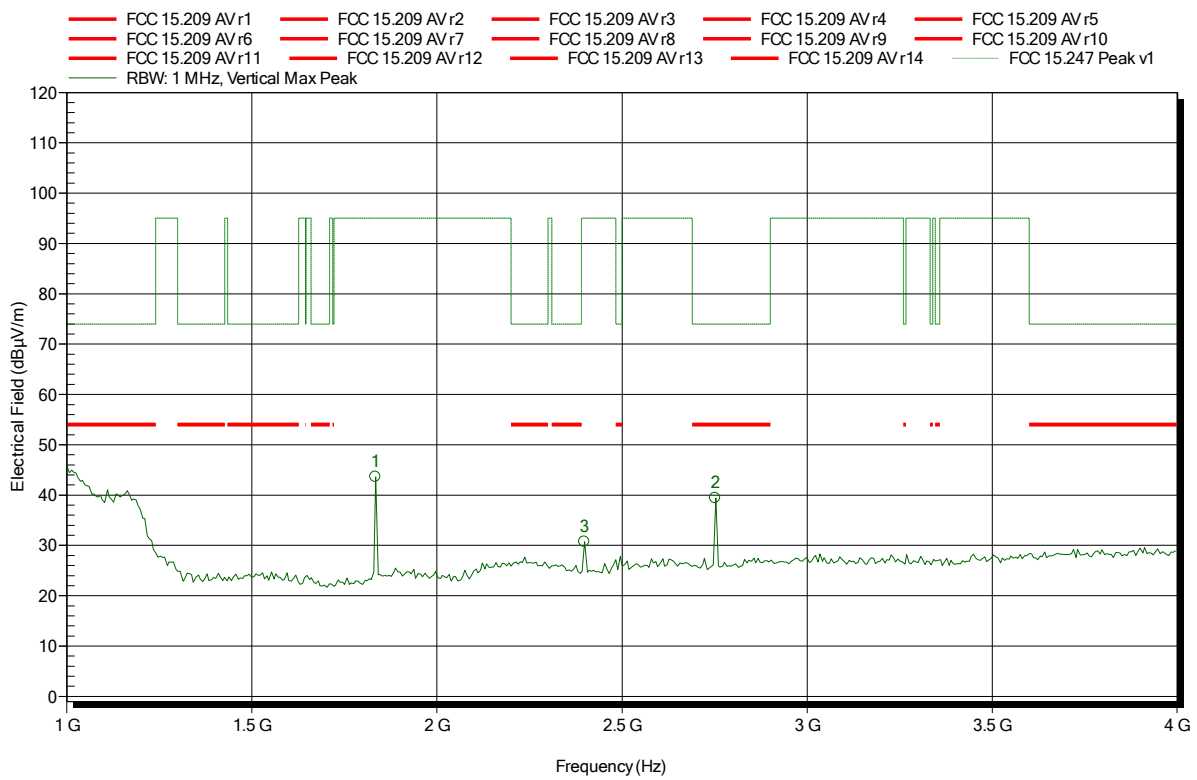

Frequency	Peak	Peak Limit	Peak Difference	Peak Status
1.834 GHz	43.6 dBµV/m	95 dBµV/m	-51.4 dB	Pass
2.398 GHz	30.75 dBµV/m	95 dBµV/m	-64.25 dB	Pass
2.752 GHz	39.43 dBµV/m	74 dBµV/m	-34.57 dB	Pass

ANNEX B Receiver spurious emissions

Spurious emissions according to RSS-Gen

Project number: G0M-1701-6190

Applicant:	Kamstrup A/S
EUT Name:	READY Converter for US/Canada market
Model:	READY Converter
Test Site:	Eurofins Product Service GmbH
Operator:	Mr. Handrik
Test Conditions:	Tnom: 21°C, Vnom: 5V DC
Antenna:	Rohde & Schwarz HK 116, Vertical
Measurement distance:	3 m
Mode:	RX; scan mode
Test Date:	2017-02-14
Note:	Roof top antenna

Index 37

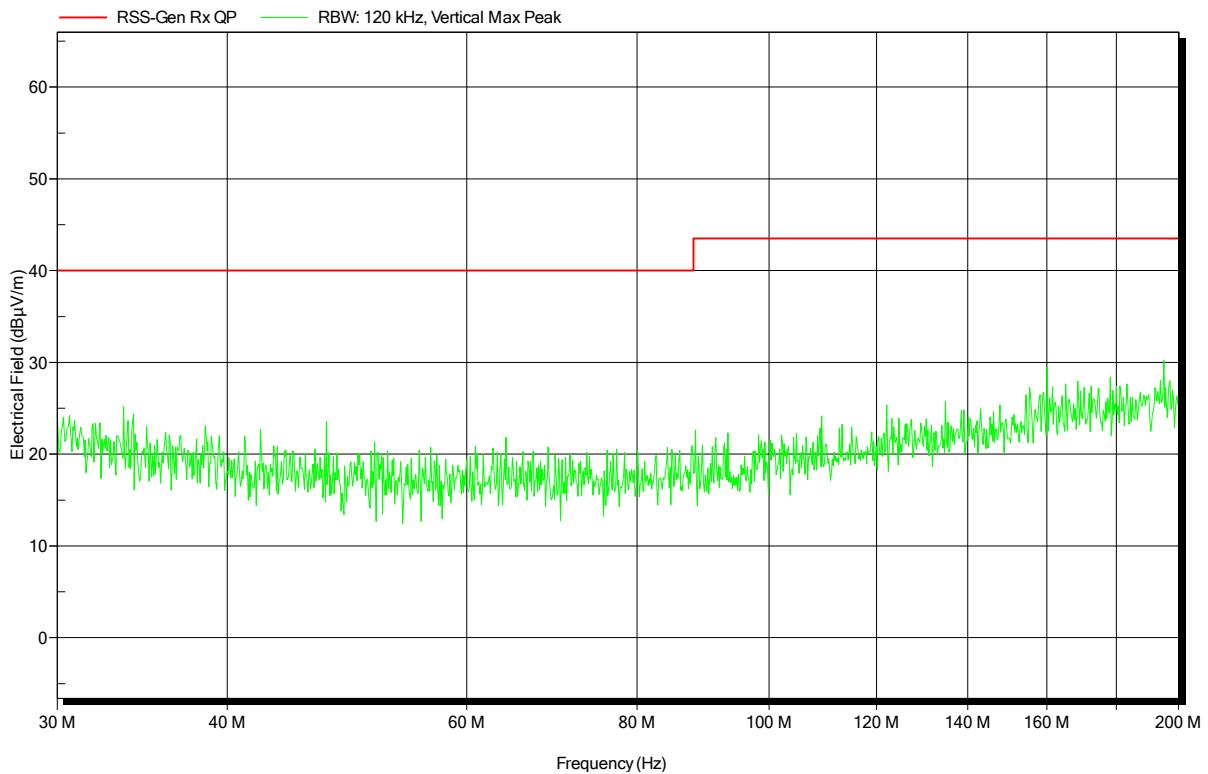

Spurious emissions according to RSS-Gen

Project number: G0M-1701-6190

Applicant: Kamstrup A/S
 EUT Name: READy Converter for US/Canada market
 Model: READy Converter
 Test Site: Eurofins Product Service GmbH
 Operator: Mr. Handrik
 Test Conditions: Tnom: 21°C, Vnom: 5V DC
 Antenna: Rohde & Schwarz HK 116, Horizontal
 Measurement distance: 3 m
 Mode: RX; scan mode
 Test Date: 2017-02-14
 Note: Roof top antenna

Index 38

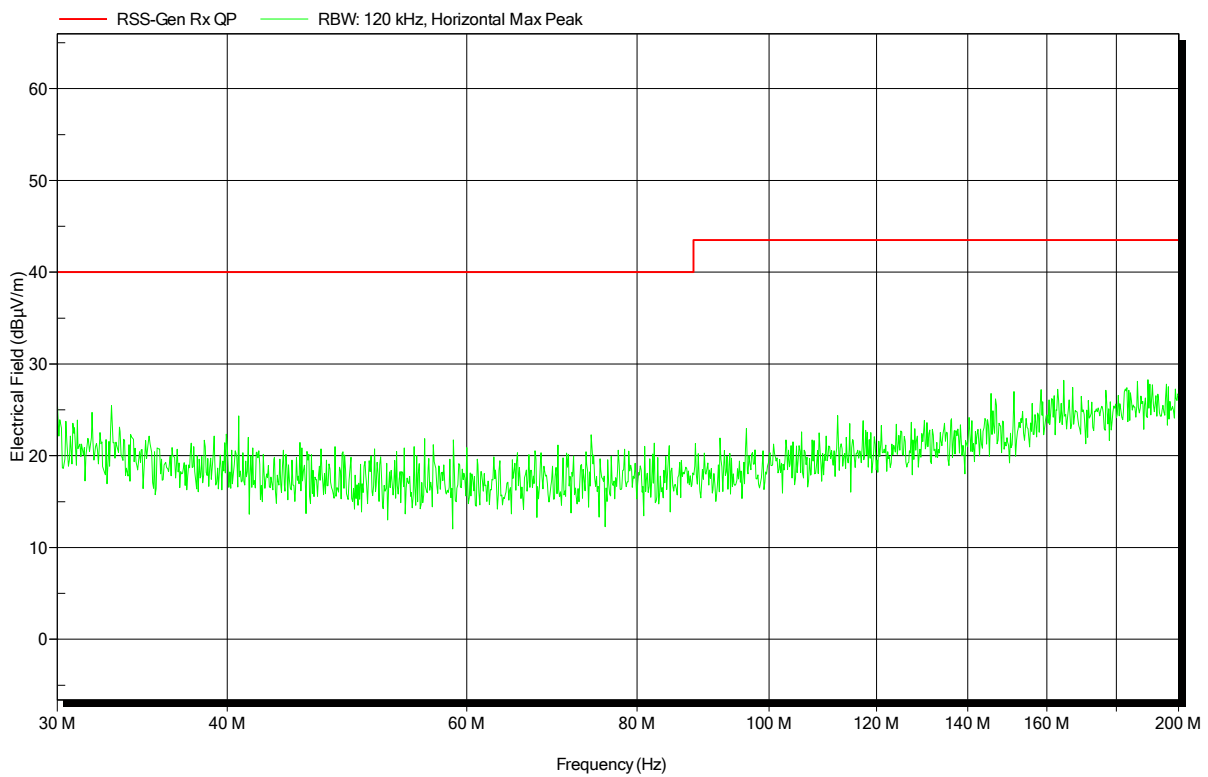

Spurious emissions according to RSS-Gen

Project number: G0M-1701-6190

Applicant: Kamstrup A/S
 EUT Name: READy Converter for US/Canada market
 Model: READy Converter
 Test Site: Eurofins Product Service GmbH
 Operator: Mr. Handrik
 Test Conditions: Tnom: 21°C, Vnom: 5V DC
 Antenna: Rohde & Schwarz HL 223, Vertical
 Measurement distance: 3 m
 Mode: RX; scan mode
 Test Date: 2017-02-14
 Note: Roof top antenna

Index 60

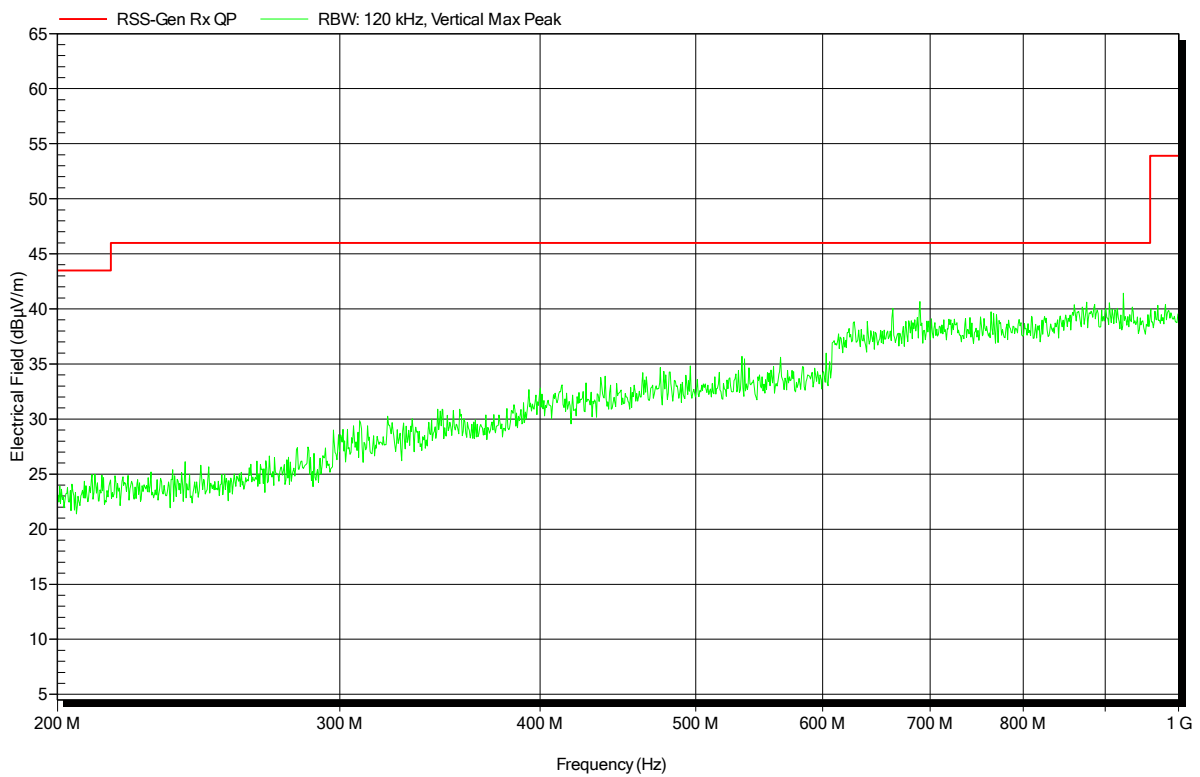

Spurious emissions according to RSS-Gen

Project number: G0M-1701-6190

Applicant: Kamstrup A/S
 EUT Name: READy Converter for US/Canada market
 Model: READy Converter
 Test Site: Eurofins Product Service GmbH
 Operator: Mr. Handrik
 Test Conditions: Tnom: 21°C, Vnom: 5V DC
 Antenna: Rohde & Schwarz HL 223, Horizontal
 Measurement distance: 3 m
 Mode: RX; scan mode
 Test Date: 2017-02-14
 Note: Roof top antenna

Index 61

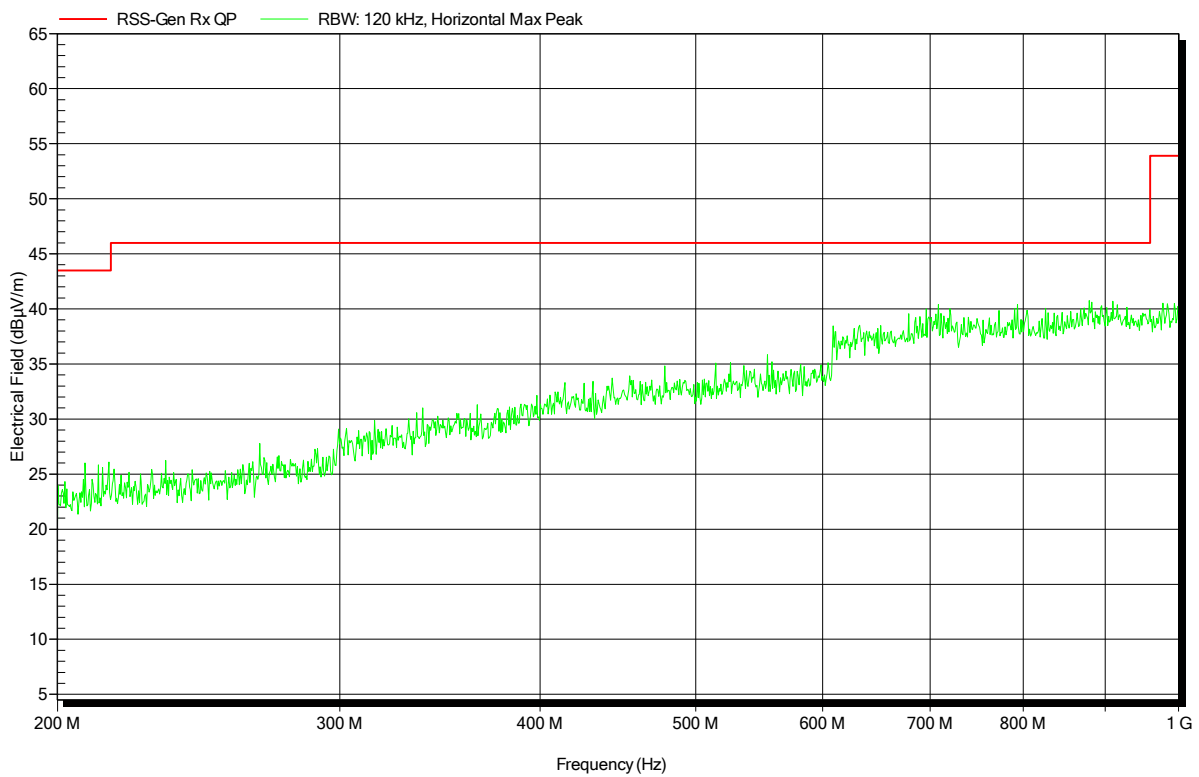

Spurious emissions according to FCC 15.247

Project number: G0M-1701-6190

Applicant:	Kamstrup A/S
EUT Name:	READY Converter for US/Canada market
Model:	READY Converter
Test Site:	Eurofins Product Service GmbH
Operator:	Mr. Suckow
Test Conditions:	Tnom: 24°C, Vnom: 5.0 VDC
Antenna:	Schwarzbeck BBHA 9120D, Horizontal
Measurement distance:	3 m
Mode:	RX; SRD 915 MHz
Test Date:	2017-02-14
Note:	Roof top antenna

Index 86

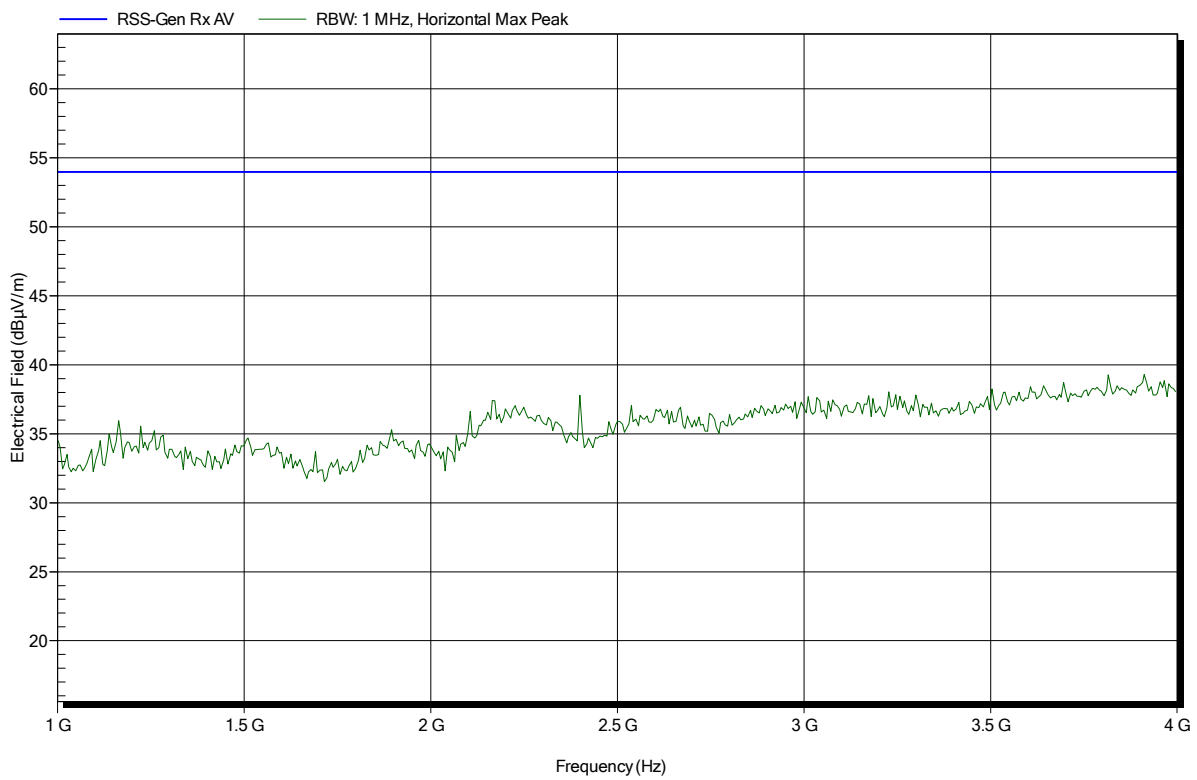

Spurious emissions according to FCC 15.247

Project number: G0M-1701-6190

Applicant: Kamstrup A/S
 EUT Name: READy Converter for US/Canada market
 Model: READy Converter
 Test Site: Eurofins Product Service GmbH
 Operator: Mr. Suckow
 Test Conditions: Tnom: 24°C, Vnom: 5.0 VDC
 Antenna: Schwarzbeck BBHA 9120D, Vertical
 Measurement distance: 3 m
 Mode: RX; SRD 915 MHz
 Test Date: 2017-02-14
 Note: Roof top antenna

Index 82

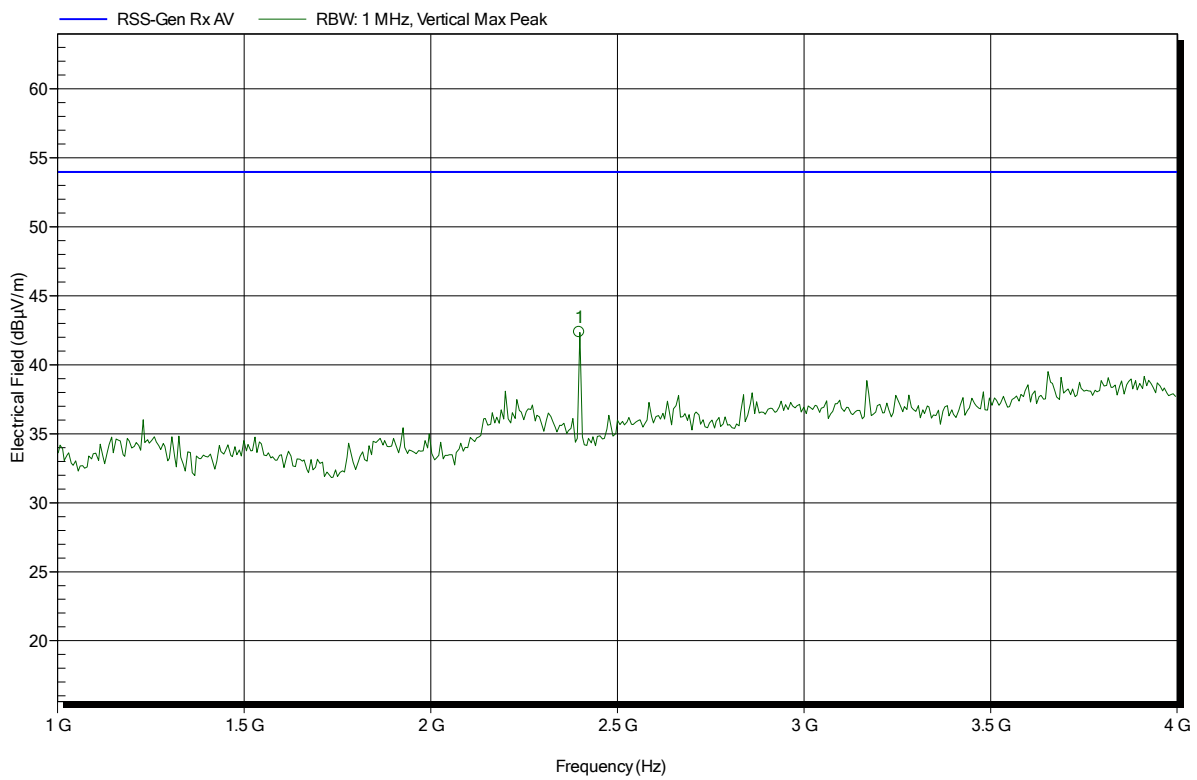

Frequency	Peak	Peak Limit	Peak Difference	Peak Status
2.398 GHz	42.38 dBµV/m	53.98 dBµV/m	-11.6 dB	Pass

Spurious emissions according to FCC 15.247

Project number: G0M-1701-6190

Applicant: Kamstrup A/S
 EUT Name: READy Converter for US/Canada market
 Model: READy Converter
 Test Site: Eurofins Product Service GmbH
 Operator: Mr. Suckow
 Test Conditions: Tnom: 24°C, Vnom: 5.0 VDC
 Antenna: Schwarzbeck BBHA 9120D, Horizontal
 Measurement distance: 3 m
 Mode: RX; SRD 915 MHz
 Test Date: 2017-02-14
 Note: Roof top antenna

Index 85

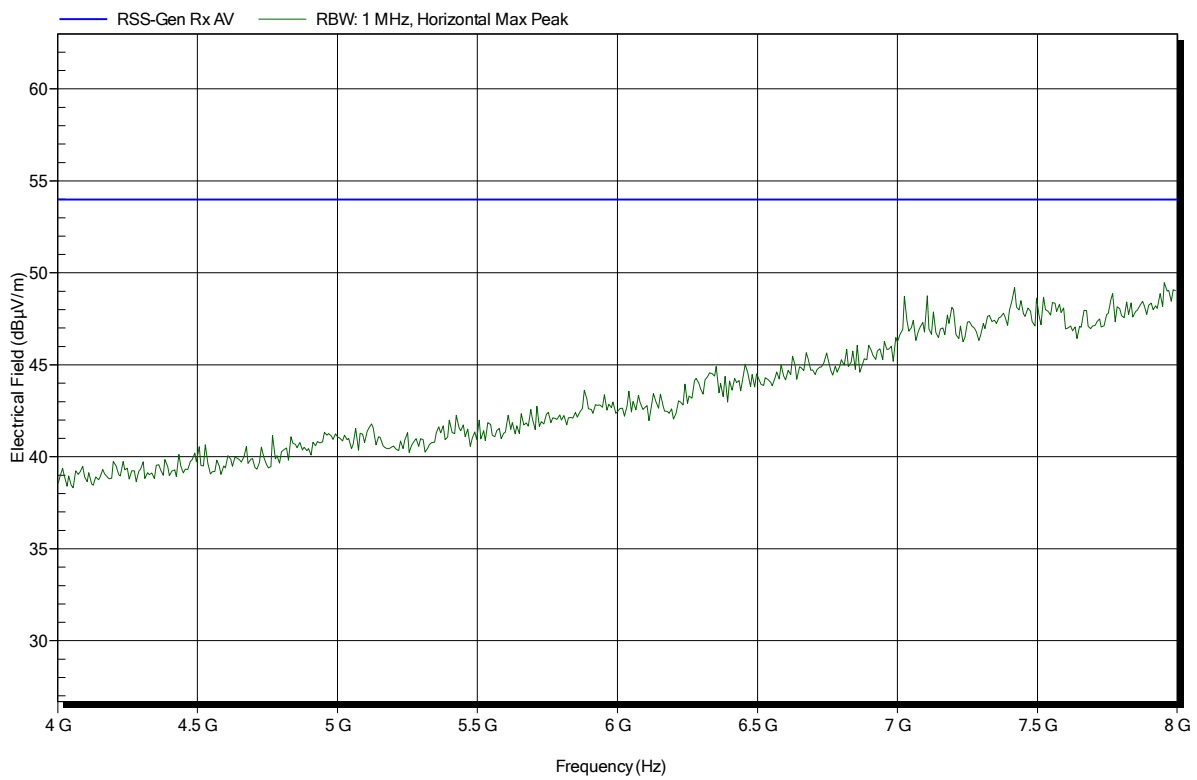

Spurious emissions according to FCC 15.247

Project number: G0M-1701-6190

Applicant: Kamstrup A/S
 EUT Name: READy Converter for US/Canada market
 Model: READy Converter
 Test Site: Eurofins Product Service GmbH
 Operator: Mr. Suckow
 Test Conditions: Tnom: 24°C, Vnom: 5.0 VDC
 Antenna: Schwarzbeck BBHA 9120D, Vertical
 Measurement distance: 3 m
 Mode: RX; SRD 915 MHz
 Test Date: 2017-02-14
 Note: Roof top antenna

Index 83

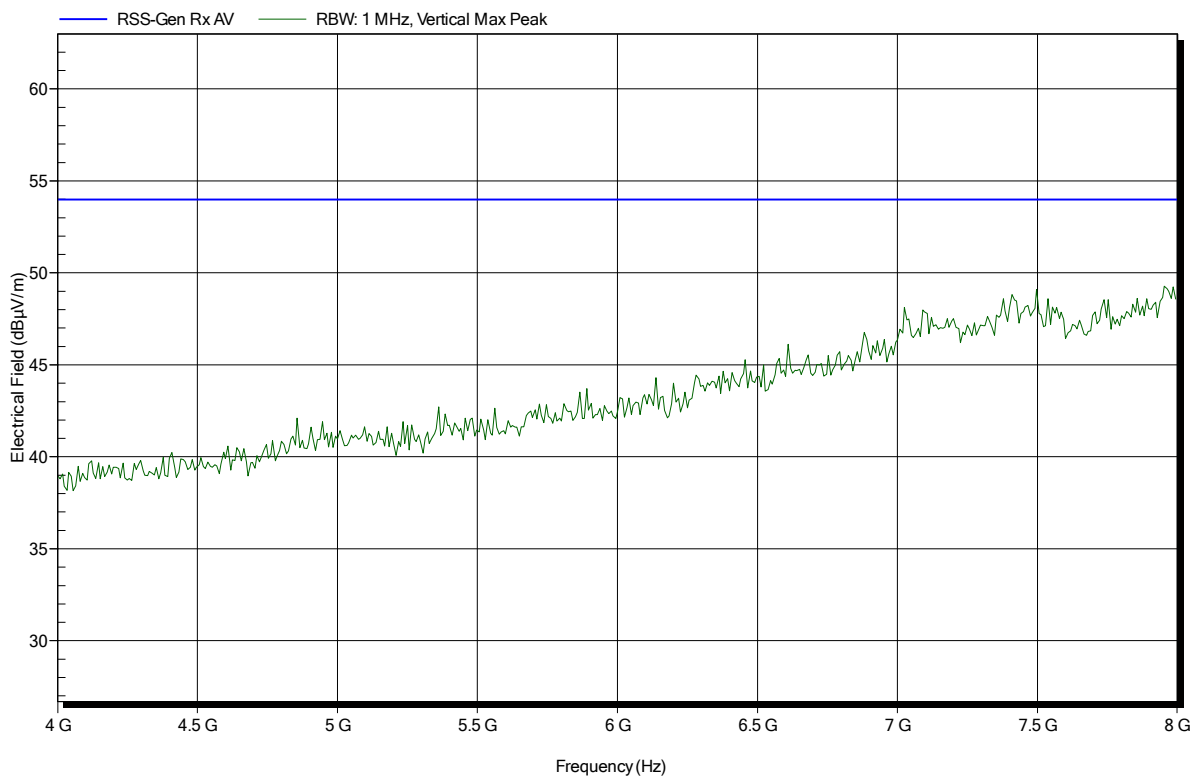

Spurious emissions according to FCC 15.247

Project number: G0M-1701-6190

Applicant: Kamstrup A/S
 EUT Name: REAdy Converter for US/Canada market
 Model: REAdy Converter
 Test Site: Eurofins Product Service GmbH
 Operator: Mr. Suckow
 Test Conditions: Tnom: 24°C, Vnom: 5.0 VDC
 Antenna: Schwarzbeck BBHA 9120D, Horizontal
 Measurement distance: 1 m converted to 3m
 Mode: RX; SRD 915 MHz
 Test Date: 2017-02-14
 Note: Roof top antenna

Index 92

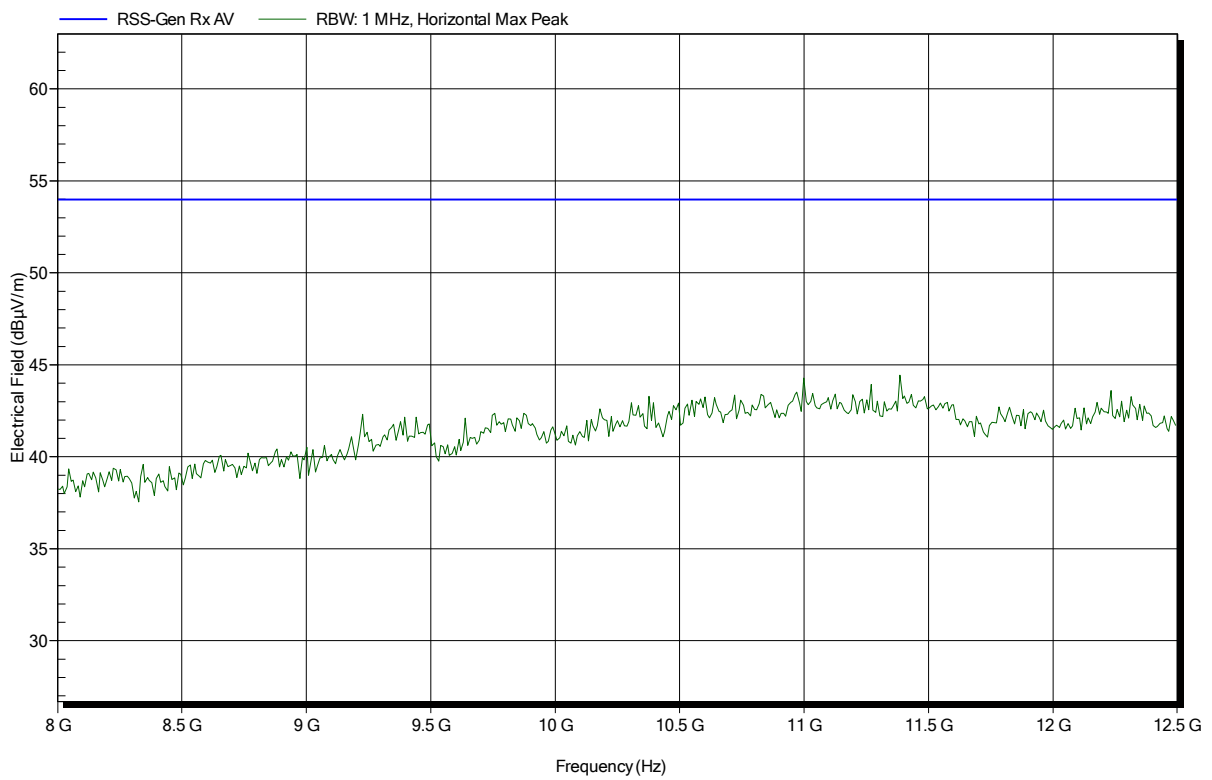

Spurious emissions according to FCC 15.247

Project number: G0M-1701-6190

Applicant: Kamstrup A/S
 EUT Name: READy Converter for US/Canada market
 Model: READy Converter
 Test Site: Eurofins Product Service GmbH
 Operator: Mr. Suckow
 Test Conditions: Tnom: 24°C, Vnom: 5.0 VDC
 Antenna: Schwarzbeck BBHA 9120D, Vertical
 Measurement distance: 1 m converted to 3m
 Mode: RX; SRD 915 MHz
 Test Date: 2017-02-14
 Note: Roof top antenna

Index 89

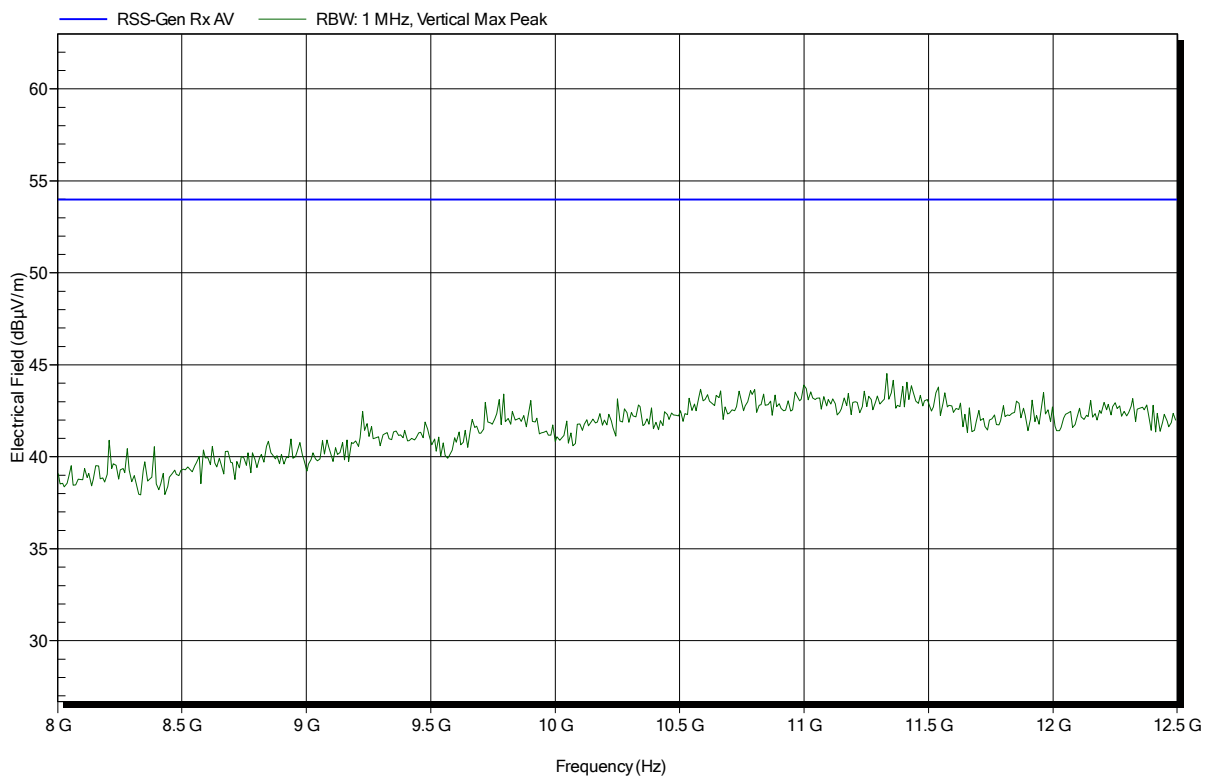

Spurious emissions according to FCC 15.247

Project number: G0M-1701-6190

Applicant: Kamstrup A/S
 EUT Name: READy Converter for US/Canada market
 Model: READy Converter
 Test Site: Eurofins Product Service GmbH
 Operator: Mr. Suckow
 Test Conditions: Tnom: 24°C, Vnom: 5.0 VDC
 Antenna: Schwarzbeck BBHA 9120D, Horizontal
 Measurement distance: 1 m converted to 3m
 Mode: RX; SRD 915 MHz
 Test Date: 2017-02-14
 Note: Roof top antenna

Index 91

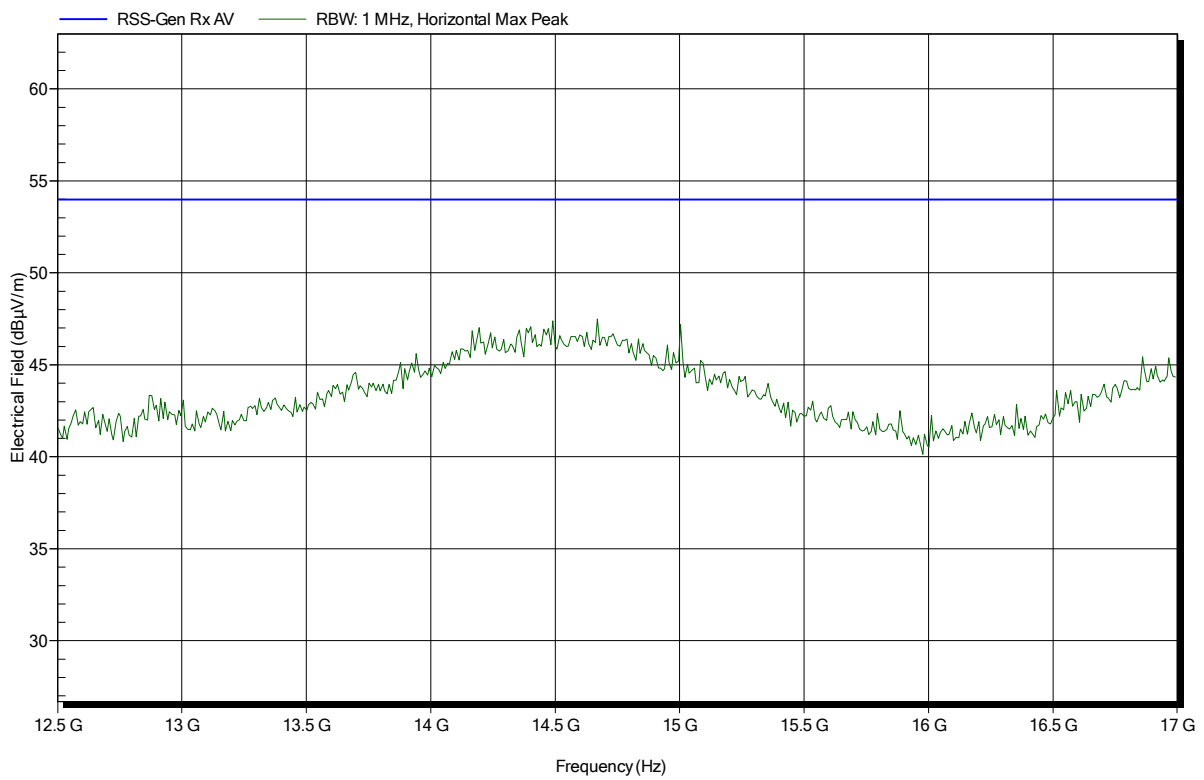

Spurious emissions according to FCC 15.247

Project number: G0M-1701-6190

Applicant: Kamstrup A/S
 EUT Name: READy Converter for US/Canada market
 Model: READy Converter
 Test Site: Eurofins Product Service GmbH
 Operator: Mr. Suckow
 Test Conditions: Tnom: 24°C, Vnom: 5.0 VDC
 Antenna: Schwarzbeck BBHA 9120D, Vertical
 Measurement distance: 1 m converted to 3m
 Mode: RX; SRD 915 MHz
 Test Date: 2017-02-14
 Note: Roof top antenna

Index 90

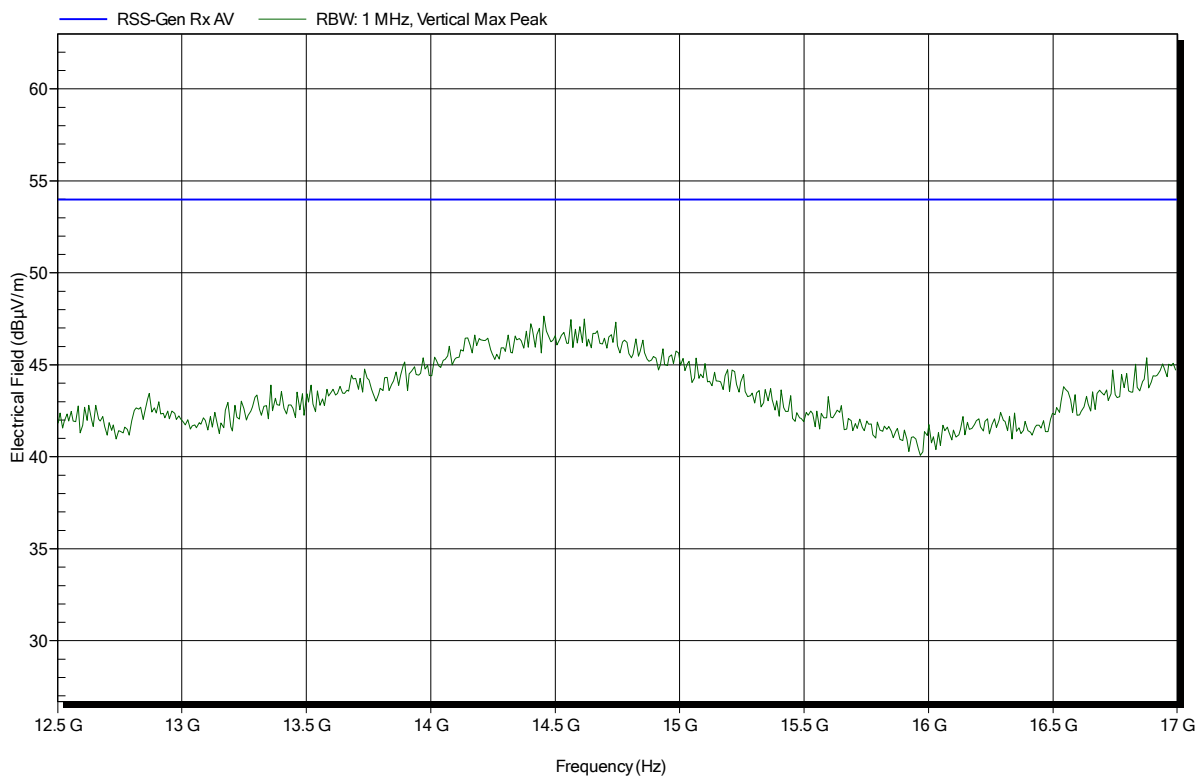

Spurious emissions according to FCC 15.247

Project number: G0M-1701-6190

Applicant: Kamstrup A/S
 EUT Name: READy Converter for US/Canada market
 Model: READy Converter
 Test Site: Eurofins Product Service GmbH
 Operator: Mr. Suckow
 Test Conditions: Tnom: 24°C, Vnom: 5.0 VDC
 Antenna: Amplifier Research AT 4560, Horizontal
 Measurement distance: 1 m converted to 3m
 Mode: RX; SRD 915 MHz
 Test Date: 2017-02-14
 Note: Roof top antenna

Index 93

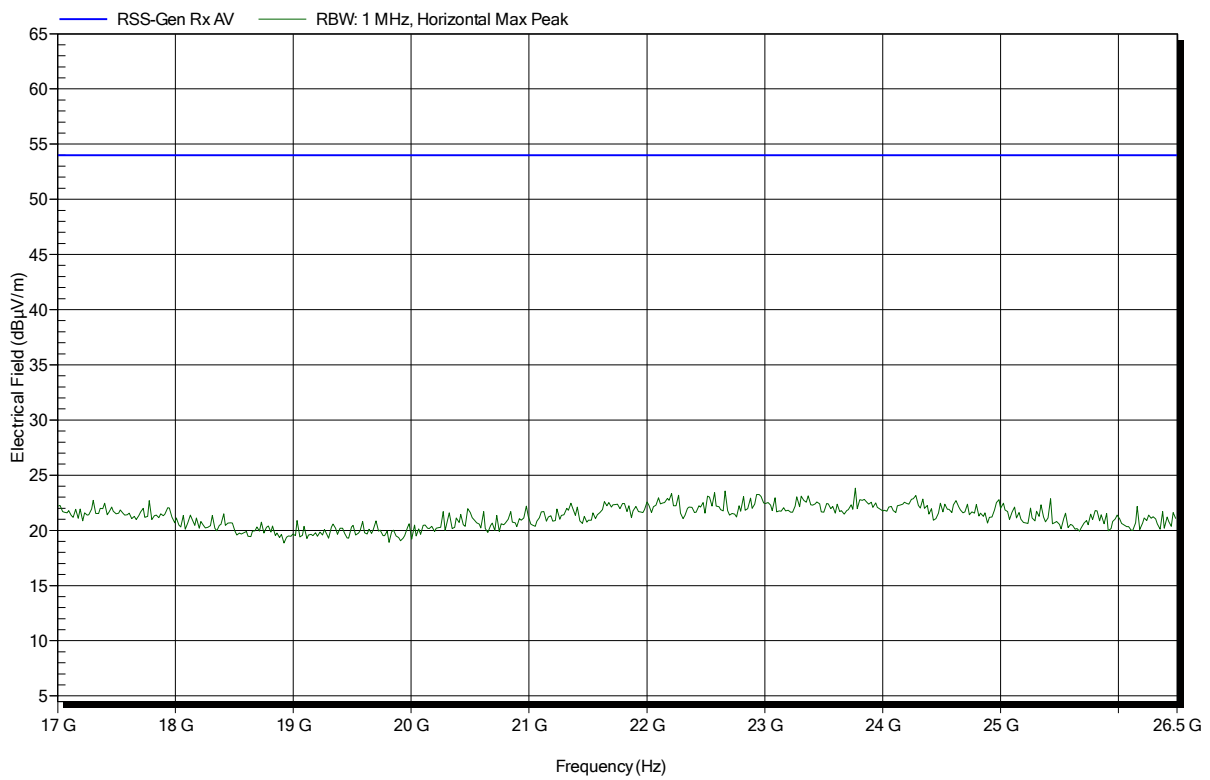

Spurious emissions according to FCC 15.247

Project number: G0M-1701-6190

Applicant: Kamstrup A/S
 EUT Name: READy Converter for US/Canada market
 Model: READy Converter
 Test Site: Eurofins Product Service GmbH
 Operator: Mr. Suckow
 Test Conditions: Tnom: 24°C, Vnom: 5.0 VDC
 Antenna: Amplifier Research AT 4560, Vertical
 Measurement distance: 1 m converted to 3m
 Mode: RX; SRD 915 MHz
 Test Date: 2017-02-14
 Note: Roof top antenna

Index 94

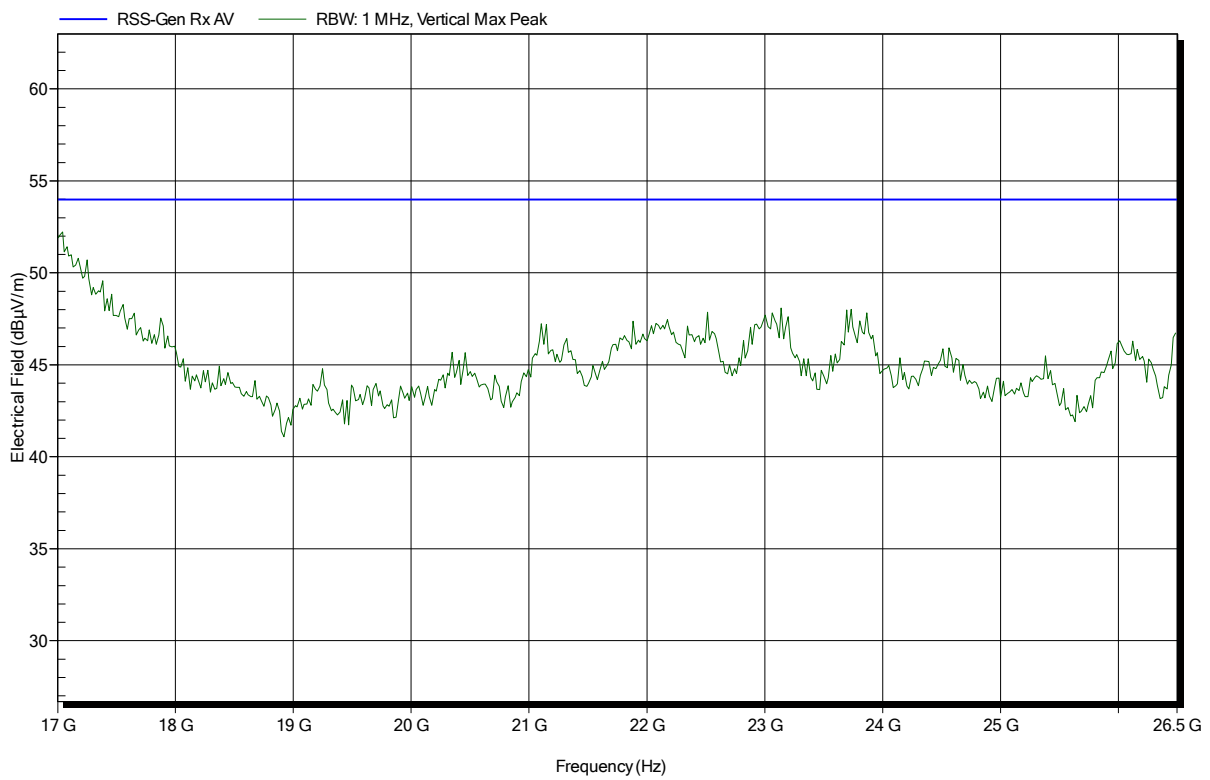

Spurious emissions according to FCC 15.247

Project number: G0M-1701-6190

Applicant: Kamstrup A/S
 EUT Name: READy Converter for US/Canada market
 Model: READy Converter
 Test Site: Eurofins Product Service GmbH
 Operator: Mr. Suckow
 Test Conditions: Tnom: 24°C, Vnom: 5.0 VDC
 Antenna: Schwarzbeck BBHA 9120D, Horizontal
 Measurement distance: 3 m
 Mode: RX; SRD 915 MHz
 Test Date: 2017-02-14
 Note: Whip antenna

Index 87

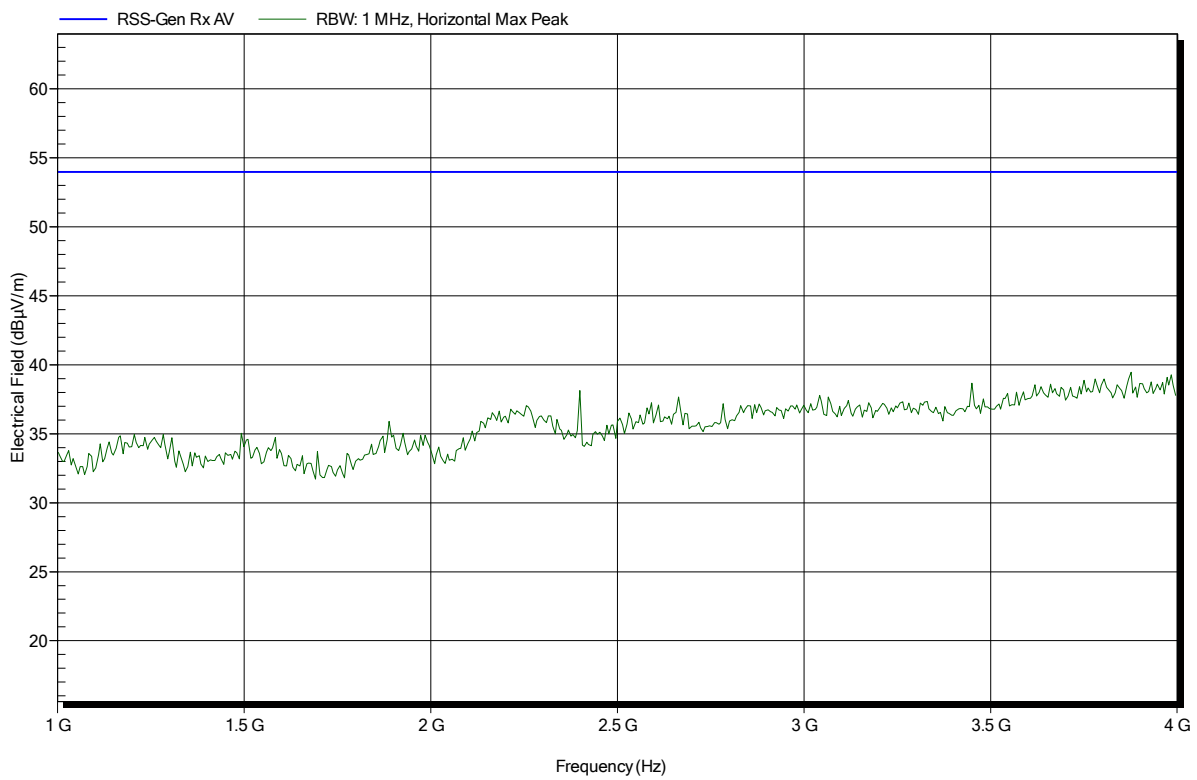

Spurious emissions according to FCC 15.247

Project number: G0M-1701-6190

Applicant: Kamstrup A/S
 EUT Name: READy Converter for US/Canada market
 Model: READy Converter
 Test Site: Eurofins Product Service GmbH
 Operator: Mr. Suckow
 Test Conditions: Tnom: 24°C, Vnom: 5.0 VDC
 Antenna: Schwarzbeck BBHA 9120D, Vertical
 Measurement distance: 3 m
 Mode: RX; SRD 915 MHz
 Test Date: 2017-02-14
 Note: Whip antenna

Index 88

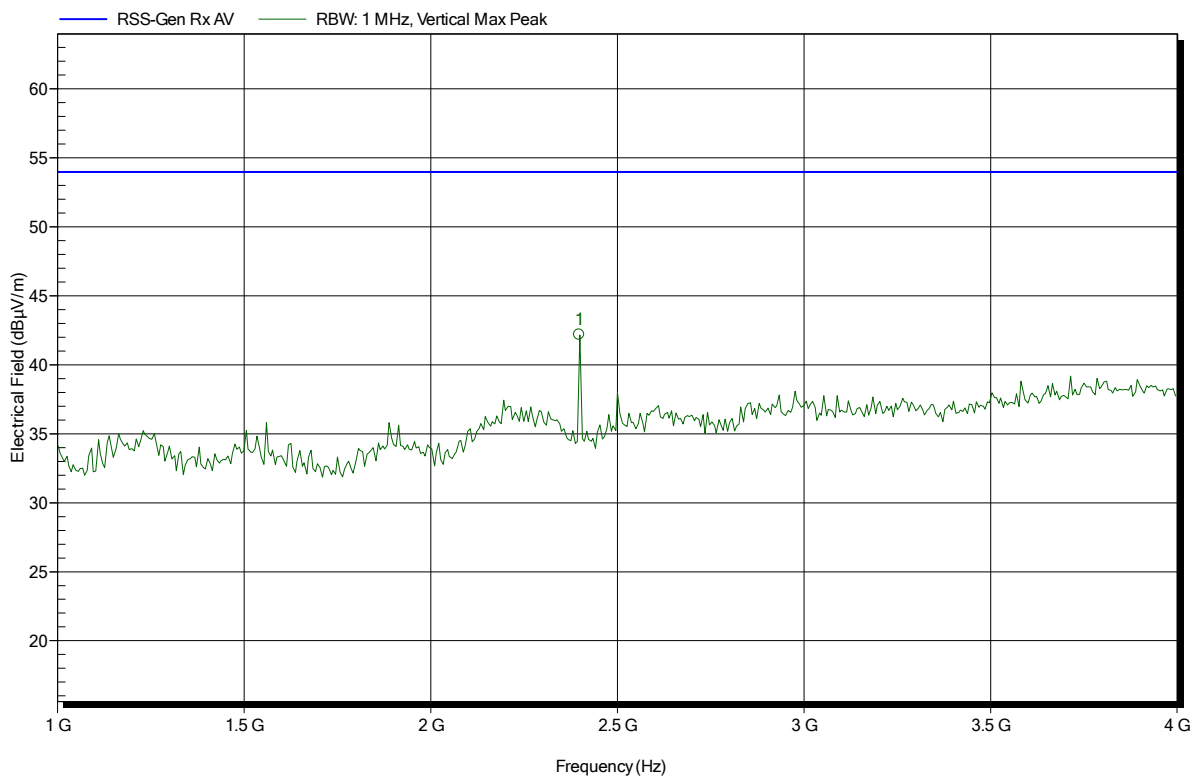

Frequency	Peak	Peak Limit	Peak Difference	Peak Status
2.398 GHz	42.18 dBµV/m	53.98 dBµV/m	-11.8 dB	Pass