





# EMI TEST REPORT

## Test Report No. 14720421H-A

Customer	NIDEC MOBILITY CORPORATION
Description of EUT	TPMS ECU
Model Number of EUT	TPMS1R
FCC ID	OUCTPMS1R
Test Regulation	FCC Part 15 Subpart B
Test Result	Complied
Issue Date	April 27, 2023
Remarks	-

<b>Representative test engineer</b>	<b>Approved by</b>
	
Nachi Konegawa Engineer	Shinichi Miyazono Engineer
 	
CERTIFICATE 5107.02	
<input type="checkbox"/> The testing in which "Non-accreditation" is displayed is outside the accreditation scopes in UL Japan, Inc.	
<input checked="" type="checkbox"/> There is no testing item of "Non-accreditation".	

Report Cover Page - Form-ULID-003532 (DCS:13-EM-F0429) Issue# 22.0

---

## **ANNOUNCEMENT**

- This test report shall not be reproduced in full or partial, without the written approval of UL Japan, Inc.
- The results in this report apply only to the sample tested. (Laboratory was not involved in sampling.)
- This sample tested is in compliance with the limits of the above regulation.
- The test results in this test report are traceable to the national or international standards.
- This test report must not be used by the customer to claim product certification, approval, or endorsement by the A2LA accreditation body.
- This test report covers EMC technical requirements. It does not cover administrative issues such as Manual or non-EMC test related Requirements. (if applicable)
- The all test items in this test report are conducted by UL Japan, Inc. Ise EMC Lab.
- The opinions and the interpretations to the result of the description in this report are outside scopes where UL Japan, Inc. has been accredited.
- The information provided from the customer for this report is identified in SECTION 1.
- For test report(s) referred in this report, the latest version (including any revisions) is always referred.

## **REVISION HISTORY**

### **Original Test Report No. 14720421H-A**

Revision	Test Report No.	Date	Page Revised Contents
- (Original)	14720421H-A	April 27, 2023	-

**Reference: Abbreviations (Including words undescribed in this report)**

A2LA	The American Association for Laboratory Accreditation	GPS	Global Positioning System
AAN	Asymmetric Artificial Network	Hori.	Horizontal
AC	Alternating Current	ICES	Interference-Causing Equipment Standard
AM	Amplitude Modulation	I/O	Input/Output
AMN	Artificial Mains Network	IEC	International Electrotechnical Commission
Amp, AMP	Amplifier	IEEE	Institute of Electrical and Electronics Engineers
ANSI	American National Standards Institute	IF	Intermediate Frequency
Ant, ANT	Antenna	ILAC	International Laboratory Accreditation Conference
AP	Access Point	ISED	Innovation, Science and Economic Development Canada
ASK	Amplitude Shift Keying	ISN	Impedance Stabilization Network
Atten., ATT	Attenuator	ISO	International Organization for Standardization
AV	Average	JAB	Japan Accreditation Board
BPSK	Binary Phase-Shift Keying	LAN	Local Area Network
BR	Bluetooth Basic Rate	LCL	Longitudinal Conversion Loss
BT	Bluetooth	LIMS	Laboratory Information Management System
BT LE	Bluetooth Low Energy	LISN	Line Impedance Stabilization Network
BW	BandWidth	MRA	Mutual Recognition Arrangement
C.F	Correction Factor	N/A	Not Applicable
Cal Int	Calibration Interval	NIST	National Institute of Standards and Technology
CAV	CISPR AV	NS	No signal detect.
CCK	Complementary Code Keying	NSA	Normalized Site Attenuation
CDN	Coupling Decoupling Network	OBW	Occupied BandWidth
Ch., CH	Channel	OFDM	Orthogonal Frequency Division Multiplexing
CISPR	Comite International Special des Perturbations Radioelectriques	PER	Packet Error Rate
Corr.	Correction	PK	Peak
CPE	Customer premise equipment	P <sub>LT</sub>	long-term flicker severity
CW	Continuous Wave	POHC(A)	Partial Odd Harmonic Current
DBPSK	Differential BPSK	Pol., Pola.	Polarization
DC	Direct Current	PR-ASK	Phase Reversal ASK
DET	Detector	P <sub>ST</sub>	short-term flicker severity
D-factor	Distance factor	QAM	Quadrature Amplitude Modulation
Dmax	maximum absolute voltage change during an observation period	QP	Quasi-Peak
DQPSK	Differential QPSK	QPSK	Quadrature Phase Shift Keying
DSSS	Direct Sequence Spread Spectrum	r.m.s., RMS	Root Mean Square
DUT	Device Under Test	RBW	Resolution BandWidth
EDR	Enhanced Data Rate	RE	Radio Equipment
e.i.r.p., EIRP	Equivalent Isotropically Radiated Power	REV	Reverse
EM clamp	Electromagnetic clamp	RF	Radio Frequency
EMC	ElectroMagnetic Compatibility	RFID	Radio Frequency Identifier
EMI	ElectroMagnetic Interference	RNSS	Radio Navigation Satellite Service
EMS	ElectroMagnetic Susceptibility	RSS	Radio Standards Specifications
EN	European Norm	Rx	Receiving
e.r.p., ERP	Effective Radiated Power	SINAD	Ratio of (Signal + Noise + Distortion) to (Noise + Distortion)
ETSI	European Telecommunications Standards Institute	S/N	Signal to Noise ratio
EU	European Union	SA, S/A	Spectrum Analyzer
EUT	Equipment Under Test	SG	Signal Generator
Fac.	Factor	SVSWR	Site-Voltage Standing Wave Ratio
FCC	Federal Communications Commission	THC(A)	Total Harmonic Current
FHSS	Frequency Hopping Spread Spectrum	THD(%)	Total Harmonic Distortion
FM	Frequency Modulation	TR, T/R	Test Receiver
Freq.	Frequency	Tx	Transmitting
FSK	Frequency Shift Keying	VBW	Video BandWidth
Fund	Fundamental	Vert.	Vertical
FWD	Forward	WLAN	Wireless LAN
GFSK	Gaussian Frequency-Shift Keying	xDSL	Generic term for all types of DSL technology
GNSS	Global Navigation Satellite System		(DSL: Digital Subscriber Line)

---

<b>CONTENTS</b>	<b>PAGE</b>
<b>SECTION 1: Customer information</b> .....	<b>5</b>
<b>SECTION 2: Equipment under test (EUT)</b> .....	<b>5</b>
<b>SECTION 3: Test specification, procedures &amp; results</b> .....	<b>6</b>
<b>SECTION 4: Operation of EUT during testing</b> .....	<b>9</b>
<b>SECTION 5: Radiated Emission</b> .....	<b>10</b>
<b>APPENDIX 1: Test data</b> .....	<b>12</b>
Radiated Emission .....	12
<b>APPENDIX 2: Test instruments</b> .....	<b>14</b>
<b>APPENDIX 3: Photographs of test setup</b> .....	<b>15</b>
Radiated Emission .....	15
Worst Case Position .....	17

## **SECTION 1: Customer information**

Company Name	NIDEC MOBILITY CORPORATION
Address	6368, Nenjo-zaka, Okusa, Komaki-city, Aichi, 485-0802 JAPAN
Telephone Number	+81-568-78-6159
Contact Person	KATO Shigeyuki

The information provided from the customer is as follows;

- Customer, Description of EUT, Model Number of EUT, FCC ID on the cover and other relevant pages
- Operating/Test Mode(s) (Mode(s)) on all the relevant pages
- SECTION 1: Customer Information
- SECTION 2: Equipment Under Test (EUT) other than the Receipt Date and Test Date
- SECTION 4: Operation of EUT during testing

\* The laboratory is exempted from liability of any test results affected from the above information in SECTION 2 and 4.

## **SECTION 2: Equipment under test (EUT)**

### **2.1 Identification of EUT**

Description	TPMS ECU
Model Number	TPMS1R
Serial Number	Refer to SECTION 4.2
Condition	Production prototype (Not for Sale: This sample is equivalent to mass-produced items.)
Modification	No Modification by the test lab
Receipt Date	April 7, 2023
Test Date	April 13, 2023

### **2.2 Product Description**

#### **General Specification**

Rating	DC 12 V
Clock frequency (ies) in the system	CPU: 20 MHz, Local clock frequency: 21.95 MHz

#### **Radio Specification**

Equipment Type	Receiver
Type of receiving system	Super-heterodyne
Frequency of Operation	314.975 MHz
Oscillator Frequency	21.95 MHz
Type of Modulation	FSK

### **SECTION 3: Test specification, procedures & results**

#### **3.1 Test Specification**

Test Specification	FCC Part 15 Subpart B The latest version on the first day of the testing period
Title	FCC 47CFR Part15 Radio Frequency Device Subpart B Unintentional Radiators

#### **3.2 Procedures and results**

Item	Test Procedure	Limits	Worst margin	Result	Remarks
Conducted emission	<b>FCC:</b> ANSI C63.4: 2014 7. AC power - line conducted emission measurements	<b>FCC:</b> Part 15 Subpart B 15.107(a)	-	N/A	*1)
	<b>ISED:</b> RSS-Gen 7.1	<b>ISED:</b> RSS-Gen 7.2			
Radiated emission	<b>FCC:</b> ANSI C63.4: 2014 8. Radiated emission measurements	<b>FCC:</b> Part 15 Subpart B 15.109(a)	23.10 dB 651.350 MHz, Horizontal / Vertical	Complied	-
	<b>ISED:</b> RSS-Gen 7.1	<b>ISED:</b> RSS-Gen 7.3			
Antenna Terminal	<b>FCC:</b> ANSI C63.4: 2014 12. Measurement of unintentional radiators other than ITE	<b>FCC:</b> Part 15 Subpart B 15.111(a)	-	N/A	*2)
	<b>ISED:</b> RSS-Gen 7.1	<b>ISED:</b> RSS-Gen 7.4			

\* Note: UL Japan, Inc.'s EMI Work Procedure: Work Instructions-ULID-003591.

\*1) The test is not applicable since the EUT is not the device that is designed to be connected to the public utility (AC) power line.

\*2) The receiving antenna (of this EUT) is installed inside the EUT and cannot be removed (permanently attached). Therefore, Radiated emission test was performed.

#### **3.3 Addition to standard**

No addition, exclusion nor deviation has been made from the standard.

### 3.4 Uncertainty

Measurement uncertainty is not taken into account when stating conformity with a specified requirement. Note: When margins obtained from test results are less than the measurement uncertainty, the test results may exceed the limit.

The following uncertainties have been calculated to provide a confidence level of 95 % using a coverage factor  $k = 2$ .

#### Radiated emission

Measurement distance	Frequency range		Uncertainty (+/-)
3 m	30 MHz to 200 MHz	Horizontal	4.8 dB
		Vertical	5.0 dB
	200 MHz to 1000 MHz	Horizontal	5.1 dB
		Vertical	6.2 dB
10 m	30 MHz to 200 MHz	Horizontal	4.8 dB
		Vertical	4.8 dB
	200 MHz to 1000 MHz	Horizontal	4.9 dB
		Vertical	5.0 dB
3 m	1 GHz to 6 GHz	Test Receiver	5.0 dB
		Spectrum analyzer	4.9 dB
	6 GHz to 18 GHz	Test Receiver	5.3 dB
		Spectrum analyzer	5.2 dB
1 m	10 GHz to 26.5 GHz	Spectrum analyzer	5.5 dB
	26.5 GHz to 40 GHz	Spectrum analyzer	5.4 dB
0.5 m	26.5 GHz to 40 GHz	Spectrum analyzer	5.4 dB
10 m	1 GHz to 18 GHz	Test Receiver	5.3 dB

### 3.5 Test Location

UL Japan, Inc. Ise EMC Lab.

4383-326 Asama-cho, Ise-shi, Mie-ken 516-0021 Japan

Telephone: +81-596-24-8999

A2LA Certificate Number: 5107.02 / FCC Test Firm Registration Number: 884919

ISED Lab Company Number: 2973C / CAB identifier: JP0002

Test site	Width x Depth x Height (m)	Size of reference ground plane (m) / horizontal conducting plane	Other rooms	Maximum measurement distance
No.1 semi-anechoic chamber	19.2 x 11.2 x 7.7	7.0 x 6.0	No.1 Power source room	10 m
No.2 semi-anechoic chamber	7.5 x 5.8 x 5.2	4.0 x 4.0	-	3 m
No.3 semi-anechoic chamber	12.0 x 8.5 x 5.9	6.8 x 5.75	No.3 Preparation room	3 m
No.3 shielded room	4.0 x 6.0 x 2.7	N/A	-	-
No.4 semi-anechoic chamber	12.0 x 8.5 x 5.9	6.8 x 5.75	No.4 Preparation room	3 m
No.4 shielded room	4.0 x 6.0 x 2.7	N/A	-	-
No.5 semi-anechoic chamber	6.0 x 6.0 x 3.9	6.0 x 6.0	-	-
No.5 measurement room	6.4 x 6.4 x 3.0	6.4 x 6.4	-	-
No.6 shielded room	4.0 x 4.5 x 2.7	4.0 x 4.5	-	-
No.6 measurement room	4.75 x 5.4 x 3.0	4.75 x 4.15	-	-
No.7 shielded room	4.7 x 7.5 x 2.7	4.7 x 7.5	-	-
No.8 measurement room	3.1 x 5.0 x 2.7	3.1 x 5.0	-	-
No.9 measurement room	8.8 x 4.6 x 2.8	2.4 x 2.4	-	-
No.10 shielded room	3.8 x 2.8 x 2.8	3.8 x 2.8	-	-
No.11 measurement room	4.0 x 3.4 x 2.5	N/A	-	-
No.12 measurement room	2.6 x 3.4 x 2.5	N/A	-	-
Large Chamber	16.9 x 22.1 x 10.17	16.9 x 22.1	-	10 m
Small Chamber	5.3 x 6.69 x 3.59	5.3 x 6.69	-	-

### 3.6 Test data, Test instruments, and Test set up

Refer to APPENDIX.



## SECTION 4: Operation of EUT during testing

### 4.1 Operating Mode(s)

Mode	1. TPMS Receiving mode
Software(s)	MCA_TPMS_314_975MHz_020001.hex Version: 020001

\*The test signal level was confirmed to be sufficient to stabilize the local oscillator of the EUT.

\* It was confirmed by using checker that the EUT receives the signal from the transmitter (pair of EUT).

### 4.2 Configuration and peripherals

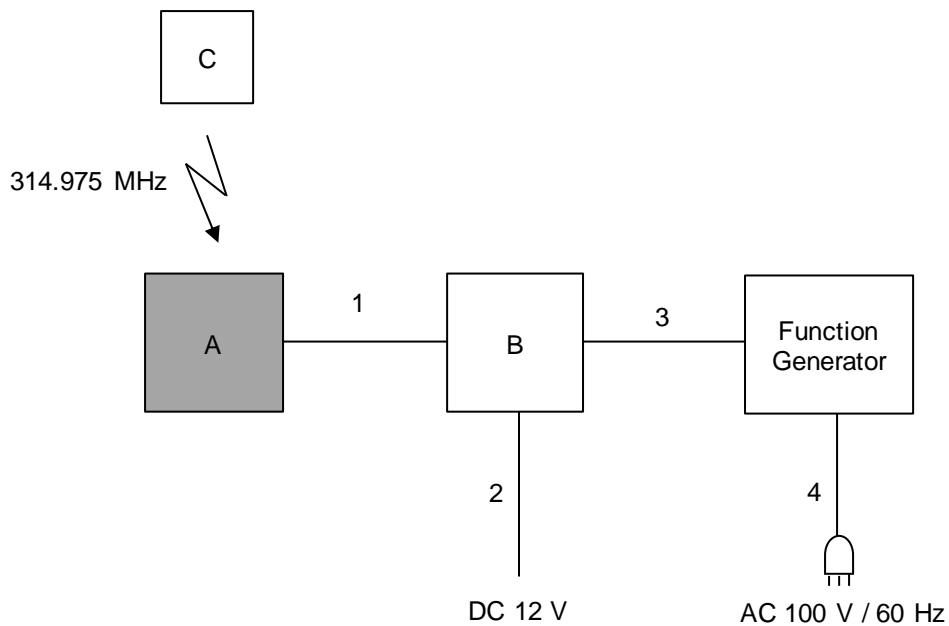

\* Cabling and setup(s) were taken into consideration and test data was taken under worse case conditions.

\* Item No. A includes Receiver Antenna.

### Description of EUT and Support Equipment

No.	Item	Model number	Serial Number	Manufacturer	Remarks
A	TPMS ECU	TPMS1R	No.1	NIDEC MOBILITY CORPORATION	EUT
B	Checker	Type1	-	NIDEC MOBILITY CORPORATION	-
C	Transmitter	Nomal	No.1	NIDEC MOBILITY CORPORATION	-

### List of Cables Used

No.	Name	Length (m)	Shield		Remarks
			Cable	Connector	
1	DC and Signal Cable	1.4	Unshielded	Unshielded	-
2	DC Cable	2.4	Unshielded	Unshielded	-
3	Signal Cable	1.5	Unshielded	Unshielded	-
4	AC Cable	1.8	Unshielded	Unshielded	-

## **SECTION 5: Radiated Emission**

### **5.1. Operating environment**

Date : See data  
Test place : See data  
Temperature : See data  
Humidity : See data  
Test engineer : See data

### **5.2. Test configuration**

EUT was placed on a urethane platform of nominal size, 1.0 m by 1.5 m, raised 0.8 m above the conducting ground plane.

The EUT was set on the edge of the tabletop.

Test was made with the antenna positioned in both the horizontal and vertical planes of polarization. The measurement antenna was varied in height above the conducting ground plane to obtain the maximum signal strength.

Photographs of the set up are shown in APPENDIX 3.

### **5.3. Test conditions**

Frequency range : 30 MHz to 200 MHz (Biconical antenna)  
200 MHz to 1000 MHz (Logperiodic antenna)  
1000 MHz to 2000 MHz (Horn antenna)  
Test distance : 3 m  
EUT position : Table top  
EUT operation mode : See Clause 4.1

### **5.4. Test procedure**

The height of the measuring antenna varied between 1 and 4 m and EUT was rotated a full revolution in order to obtain the maximum value of the electric field intensity.

The measurements were performed for both vertical and horizontal antenna polarization with the Test Receiver

The radiated emission measurements were made with the following detector function of the Test Receiver  
Test antenna was aimed at the emission source for receiving the maximum signal and always kept. (Above 1 GHz)

Frequency	Below 1GHz	Above 1GHz *1)
Instrument used	Test Receiver	Test Receiver
IF Bandwidth	QP: BW 120 kHz	PK: BW 1 MHz, CAV: BW 1 MHz

\*1) The measurement data was adjusted to a 3 m distance using the following Distance Factor.  
Distance Factor: See Figure 1

Figure 1: Test Setup

Below 1 GHz

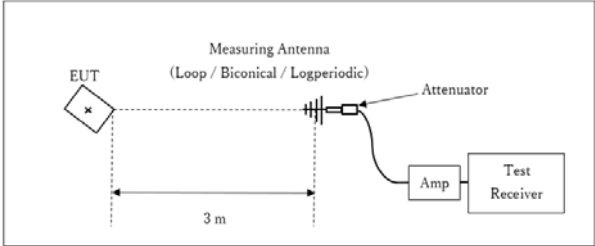

Test Distance: 3 m

\* : Center of turn table

1 GHz to 2 GHz

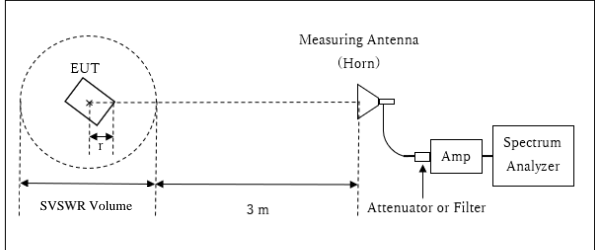

Distance Factor:  $20 \times \log(3.40 \text{ m}^*/3.0 \text{ m}) = 1.09 \text{ dB}$   
\* Test Distance:  $(3 + \text{SVSWR Volume} / 2) - r = 3.40 \text{ m}$

SVSWR Volume: 1.5 m  
(SVSWR Volume has been calibrated based on CISPR 16-1-4.)  
 $r = 0.35 \text{ m}$

r : Radius of an outer periphery of EUT  
\* : Center of turn table

- The noise levels were confirmed at each position of X, Y and Z axes of EUT to see the position of maximum noise, and the test was made at the position that has the maximum noise.

5.5. Test result

Summary of the test results: Pass

The limit is rounded down to one decimal place.  
The test result is rounded off to one or two decimal places, so some differences might be observed.

**APPENDIX 1: Test data**

**Radiated Emission**

Test place                                   Ise EMC Lab.  
Semi Anechoic Chamber                No.2  
Date   April 13, 2023  
Temperature / Humidity                 21 deg. C / 28 % RH  
Engineer                                   Nachi Konegawa  
  (Below 1 GHz)  
Mode   Mode 1

Limit : FCC\_Part 15 Subpart B(15.109)\_Class B

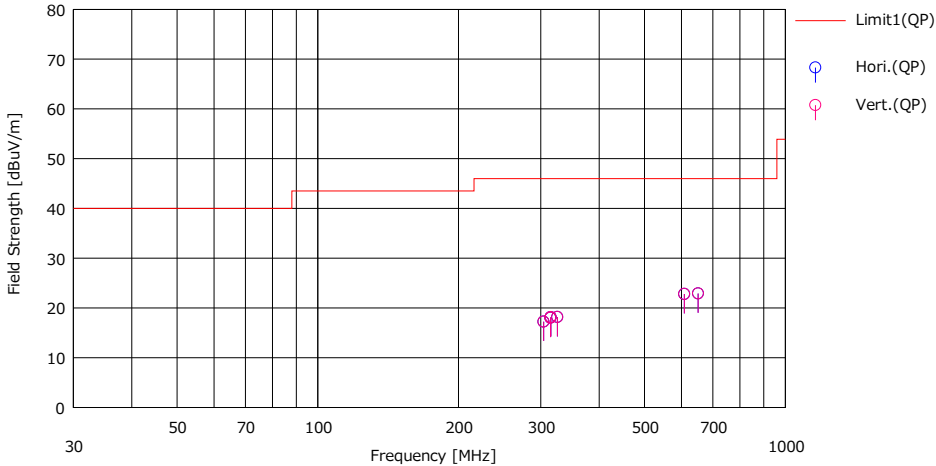

No.	Freq. [MHz]	Reading	Ant.Fac. [dB/m]	Loss [dB]	Gain [dB]	Result	Limit	Margn	Pda	Height [cm]	Angle [deg]	Ant. Type	Comment
		[dBuV]				[dBuV/m]	[QP]	[QP]					
1	304.275	22.30	13.98	8.71	27.77	17.22	46.00	28.78	Hori.	100	0	LA21	NS
2	314.701	22.70	14.37	8.77	27.84	18.00	46.00	28.00	Hori.	100	0	LA21	NS
3	315.249	22.80	14.40	8.78	27.84	18.14	46.00	27.86	Hori.	100	0	LA21	NS
4	325.675	22.30	14.93	8.83	27.90	18.16	46.00	27.84	Hori.	100	0	LA21	NS
5	608.550	22.40	19.48	10.21	29.30	22.79	46.00	23.21	Hori.	100	0	LA21	NS
6	651.350	22.50	19.38	10.34	29.32	22.90	46.00	23.10	Hori.	100	0	LA21	NS
7	304.275	22.30	13.98	8.71	27.77	17.22	46.00	28.78	Vert.	100	0	LA21	NS
8	314.701	22.70	14.37	8.77	27.84	18.00	46.00	28.00	Vert.	100	0	LA21	NS
9	315.249	22.80	14.40	8.78	27.84	18.14	46.00	27.86	Vert.	100	0	LA21	NS
10	325.675	22.30	14.93	8.83	27.90	18.16	46.00	27.84	Vert.	100	0	LA21	NS
11	608.550	22.40	19.48	10.21	29.30	22.79	46.00	23.21	Vert.	100	0	LA21	NS
12	651.350	22.50	19.38	10.34	29.32	22.90	46.00	23.10	Vert.	100	0	LA21	NS

CHART: WITH FACTOR  
ANT TYPE: - 30 MHz: LOOP, 30 MHz - 200 MHz: BICONICAL, 200 MHz - 1000 MHz: LOGPERIODIC, 1000 MHz -: HORN  
CALCULATION: RESULT = READING + ANT FACTOR + LOSS(CABLE + ATT) - GAIN(AMP)  
Except for the above table: adequate margin data below the limits.

**Radiated Emission**

Test place Ise EMC Lab.  
Semi Anechoic Chamber No.2  
Date April 13, 2023  
Temperature / Humidity 21 deg. C / 28 % RH  
Engineer Nachi Konegawa  
(Above 1 GHz)  
Mode Mode 1

Limit : FCC\_Part 15 Subpart B(15.109)\_Class B

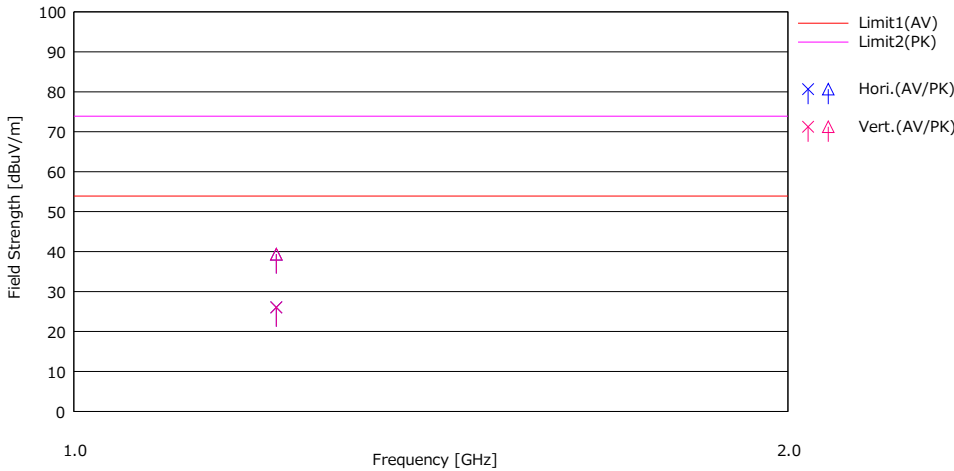

No.	Freq. [MHz]	Reading		Ant.Fac [dB/m]	Loss [dB]	Gain [dB]	Result		Limit		Margin		Pola. [H/V]	Height [cm]	Angle [deg]	Ant. Type	Comment
		(AV) [dBuV]	(PK) [dBuV]				(AV) [dBuV/m]	(PK) [dBuV/m]	(AV) [dBuV/m]	(PK) [dBuV/m]	(AV) [dB]	(PK) [dB]					
1	1217.100	33.40	46.70	25.58	2.87	35.81	26.04	39.34	53.90	73.90	27.86	34.56	Hori.	100	0	HA6	NS
2	1217.100	33.40	46.70	25.58	2.87	35.81	26.04	39.34	53.90	73.90	27.86	34.56	Vert.	100	0	HA6	NS

CHART: WITH FACTOR  
ANT TYPE: - 30 MHz: LOOP, 30 MHz - 200 MHz: BICONICAL, 200 MHz - 1000 MHz: LOGPERIODIC, 1000 MHz -: HORN  
CALCULATION: RESULT = READING + ANT FACTOR + LOSS(CABLE + D-factor) - GAIN(AMP)  
Except for the above table: adequate margin data below the limits.

## APPENDIX 2: Test instruments

### Test equipment

Test Item	Local ID	LIMS ID	Description	Manufacturer	Model	Serial	Last Calibration Date	Cal Int
RE	COTS-MEMI-02	178648	EMI measurement program	TSJ (Techno Science Japan)	TEPTO-DV	-	-	-
RE	MAEC-02	142004	AC2_Semi Anechoic Chamber(NSA)	TDK	Semi Anechoic Chamber 3m	DA-06902	05/30/2022	24
RE	MAEC-02-SVSWR	142006	AC2_Semi Anechoic Chamber(SVSWR)	TDK	Semi Anechoic Chamber 3m	DA-06902	04/09/2021	24
RE	MAT-112	220646	Attenuator	Huber+Suhner	6806_N-50-1	-	03/17/2023	12
RE	MBA-08	141427	Biconical Antenna	Schwarzbeck Mess-Elektronik OHG	VHA9103B+BB A9106	08031	07/30/2022	12
RE	MCC-12	141317	Coaxial Cable	UL Japan	-	-	09/27/2022	12
RE	MCC-218	141394	Microwave Cable	Junkosha	MWX221	1607S141(1 m) / 1608S264(5 m)	09/12/2022	12
RE	MHA-06	141512	Horn Antenna 1-18GHz	Schwarzbeck Mess-Elektronik OHG	BBHA9120D	254	10/20/2022	12
RE	MLA-21	141265	Logperiodic Antenna(200-1000MHz)	Schwarzbeck Mess-Elektronik OHG	VUSLP9111B	9111B-190	07/30/2022	12
RE	MMM-01	141542	Digital Tester	Fluke Corporation	FLUKE 26-3	78030611	08/12/2022	12
RE	MOS-41	192300	Thermo-Hygrometer	CUSTOM. Inc	CTH-201	0013	12/17/2022	12
RE	MPA-10	141579	Pre Amplifier	Keysight Technologies Inc	8449B	3008A02142	02/14/2023	12
RE	MPA-24	141594	Pre Amplifier	Keysight Technologies Inc	8447D	2944A10150	02/02/2023	12
RE	MTR-08	141949	Test Receiver	Rohde & Schwarz	ESCI	100767	07/29/2022	12

\*Hyphens for Last Calibration Date and Cal Int (month) are instruments that Calibration is not required (e.g. software), or instruments checked in advance before use.

The expiration date of the calibration is the end of the expired month.

As for some calibrations performed after the tested dates, those test equipment have been controlled by means of an unbroken chains of calibrations.

All equipment is calibrated with valid calibrations. Each measurement data is traceable to the national or international standards.

Test item:

RE: Radiated emission