



RADIO TEST REPORT

Test Report No. : 11421068H-A-R3

Applicant : OMRON Automotive Electronics Co. Ltd.
Type of Equipment : UNIT ASSY, NFC
Model No. : GHW-H003
Test regulation : FCC Part 15 Subpart C: 2016
FCC ID : OUCGHWH003
Test Result : **Complied**

1. This test report shall not be reproduced in full or partial, without the written approval of UL Japan, Inc.
2. The results in this report apply only to the sample tested.
3. This sample tested is in compliance with above regulation.
4. The test results in this report are traceable to the national or international standards.
5. This test report must not be used by the customer to claim product certification, approval, or endorsement by NVLAP, NIST, or any agency of the Federal Government.
6. This test report covers Radio technical requirements. It does not cover administrative issues such as Manual or non-Radio test related Requirements. (if applicable)
7. This report is a revised version of 11421068H-A-R2. 11421068H-A-R2 is replaced with this report.

Date of test: January 5 to February 22, 2017

Representative test engineer:

Ken Fujita

Ken Fujita

Engineer

Consumer Technology Division

Approved by:

M. Imura

Motoya Imura

Engineer

Consumer Technology Division



NVLAP LAB CODE: 200572-0

This laboratory is accredited by the NVLAP LAB CODE 200572-0, U.S.A. The tests reported herein have been performed in accordance with its terms of accreditation.

*As for the range of Accreditation in NVLAP, you may refer to the WEB address,

http://japan.ul.com/resources/emc_accredited/

UL Japan, Inc.

Ise EMC Lab.

4383-326 Asama-cho, Ise-shi, Mie-ken 516-0021 JAPAN

Telephone : +81 596 24 8999

Facsimile : +81 596 24 8124

13-EM-F0429

CONTENTS	PAGE
SECTION 1: Customer information	4
SECTION 2: Equipment under test (E.U.T.)	4
SECTION 3: Test specification, procedures & results	5
SECTION 4: Operation of E.U.T. during testing	8
SECTION 5: Conducted emission	10
SECTION 6: Radiated emission (Fundamental , Spurious Emission and Spectrum Mask)	11
SECTION 7: Other test	12
APPENDIX 1: Test data	13
Conducted emission	13
Fundamental emission and Spectrum Mask	21
Spurious emission	29
20dB Bandwidth and 99% Occupied Bandwidth	45
Frequency Tolerance	49
APPENDIX 2: Test instruments	50
APPENDIX 3: Photographs of test setup	51
Conducted emission	51
Radiated emission	52
Worst Case Position	53

UL Japan, Inc.

Ise EMC Lab.

4383-326 Asama-cho, Ise-shi, Mie-ken 516-0021 JAPAN

Telephone : +81 596 24 8999

Facsimile : +81 596 24 8124

SECTION 1: Customer information

Company Name : OMRON Automotive Electronics Co. Ltd.
Address : 6368 NENJOZAKA OKUSA KOMAKI AICHI, 485-0802 JAPAN
Telephone Number : +81-568-78-6159
Facsimile Number : +81-568-78-7659
Contact Person : Masashi Matsuda

SECTION 2: Equipment under test (E.U.T.)

2.1 Identification of E.U.T.

Type of Equipment : UNIT ASSY, NFC
Model No. : GHW-H003
Serial No. : Refer to Section 4, Clause 4.2
Receipt Date of Sample : January 5, 2017
Country of Mass-production : Japan
Condition of EUT : Production model
Modification of EUT : No Modification by the test lab

2.2 Product Description

Radio Specification

Radio Type : Transceiver
Frequency of Operation : 13.56 MHz
Modulation : ASK
Power Supply (inner) : DC 3.6 V
Antenna type : Pattern Antenna
Clock frequency (Maximum) : 27.12 MHz (Crystal Oscillator)
Operating Temperature : -30 deg.C to +70 deg.C

SECTION 3: Test specification, procedures & results

3.1 Test Specification

Test Specification : FCC Part 15 Subpart C
FCC Part 15 final revised on November 14, 2016 and effective December 14, 2016

Title : FCC 47CFR Part15 Radio Frequency Device Subpart C Intentional Radiators
Section 15.207 Conducted limits
Section 15.225 : Operation within the band 13.110-14.010MHz

3.2 Procedures and results

Item	Test Procedure	Specification	Worst margin	Results	Remarks
Conducted emission	ANSI C63.10:2013 6 Standard test methods	Section 15.207	[QP] 5.3 dB 0.20800 MHz, L	Complied *1)	-
	<IC>RSS-Gen 8.8	<IC>RSS-Gen 8.8	[AV] 4.7 dB 13.56000 MHz, L		
Electric Field Strength of Fundamental Emission	ANSI C63.10:2013 6 Standard test methods	Section 15.225(a)	57.0 dB, 13.56000 MHz, QP, 0 deg.	Complied	Radiated
	<IC> RSS-Gen 6.4, 6.12	<IC>RSS-210 B.6			
Spectrum Mask	ANSI C63.10:2013 6 Standard test methods	Section 15.225(b)(c)	36.7 dB, 13.41000 MHz, 13.71000 MHz	Complied	Radiated
	<IC>RSS-Gen 6.4, 6.13	<IC> RSS-210 B.6	QP, 0 deg.		
20dB Bandwidth	ANSI C63.10:2013 6 Standard test methods	Section15.215(c)	See data	Complied	Radiated
	<IC> -	<IC> -			
Electric Field Strength of Spurious Emission	ANSI C63.10:2013 6 Standard test methods	Section 15.209, Section 15.225 (d)	8.3 dB 59.932 MHz, Vertical, QP	Complied	Radiated
	<IC>RSS-Gen 6.4, 6.13	<IC>RSS-210 B.6			
Frequency Tolerance	ANSI C63.10:2013 6 Standard test methods	Section 15.225(e)	See data	Complied	Radiated
	<IC>RSS-Gen 6.11, 8.11	<IC> RSS-210 B.6			

Note: UL Japan, Inc.'s EMI Work Procedures No. 13-EM-W0420 and 13-EM-W0422

*1) This test data was acquired as the reference data since the EUT does not connected to the public utility (AC) power line use (Use of the in-vehicle environment only).

FCC 15.31 (e)

The stable voltage was supplied by the end product which was required to have a power supply regulator. Therefore, the EUT complies with the requirement.

However, the supply voltage was varied and tested at 85 % and 115 % of the nominal rated supply voltage during frequency tolerance test according to Section 15.225(e).

FCC Part 15.203 Antenna requirement

The antenna is not removable from the EUT. Therefore, the equipment complies with the antenna requirement of Section 15.203.

UL Japan, Inc.

Ise EMC Lab.

4383-326 Asama-cho, Ise-shi, Mie-ken 516-0021 JAPAN

Telephone : +81 596 24 8999

Facsimile : +81 596 24 8124

3.3 Addition to standard

No.	Item	Test Procedure	Specification	Remarks	Deviation	Worst margin	Results
1	99 % Occupied Band Width	RSS-Gen 6.6	-	Radiated	N/A	N/A	N/A

Other than above, no addition, exclusion nor deviation has been made from the standard.

3.4 Uncertainty

EMI

The following uncertainties have been calculated to provide a confidence level of 95% using a coverage factor $k = 2$.

Frequency range	Conducted emission using AMN(LISN) (+/-)
0.009 – 0.15MHz	3.5 dB
0.15 – 30MHz	3.0 dB

Test distance	Radiated emission (+/-)
	9 kHz - 30 MHz
3m	3.8 dB
10m	3.7 dB

*Measurement distance

Polarity	Radiated emission (Below 1GHz)			
	(3 m*)(+/-)		(10 m*)(+/-)	
	30 – 200 MHz	200 – 1000MHz	30 – 200 MHz	200 – 1000MHz
Horizontal	5.0 dB	5.3 dB	5.0 dB	5.0 dB
Vertical	4.7 dB	5.9 dB	5.0 dB	5.1 dB

* Measurement distance

Frequency counter (+)	
Normal condition	Extreme condition
7×10^{-6}	9×10^{-6}

Conducted emission test

The data listed in this test report has enough margin, more than the site margin.

Radiated emission test (3m)

The data listed in this test report has enough margin, more than the site margin.

3.5 Test Location

UL Japan, Inc. Ise EMC Lab. *NVLAP Lab. code: 200572-0
4383-326 Asama-cho, Ise-shi, Mie-ken 516-0021 JAPAN
Telephone : +81 596 24 8999 Facsimile : +81 596 24 8124

	IC Registration Number	Width x Depth x Height (m)	Size of reference ground plane (m) / horizontal conducting plane	Other rooms
No.1 semi-anechoic chamber	2973C-1	19.2 x 11.2 x 7.7m	7.0 x 6.0m	No.1 Power source room
No.2 semi-anechoic chamber	2973C-2	7.5 x 5.8 x 5.2m	4.0 x 4.0m	-
No.3 semi-anechoic chamber	2973C-3	12.0 x 8.5 x 5.9m	6.8 x 5.75m	No.3 Preparation room
No.3 shielded room	-	4.0 x 6.0 x 2.7m	N/A	-
No.4 semi-anechoic chamber	2973C-4	12.0 x 8.5 x 5.9m	6.8 x 5.75m	No.4 Preparation room
No.4 shielded room	-	4.0 x 6.0 x 2.7m	N/A	-
No.5 semi-anechoic chamber	-	6.0 x 6.0 x 3.9m	6.0 x 6.0m	-
No.6 shielded room	-	4.0 x 4.5 x 2.7m	4.0 x 4.5 m	-
No.6 measurement room	-	4.75 x 5.4 x 3.0m	4.75 x 4.15 m	-
No.7 shielded room	-	4.7 x 7.5 x 2.7m	4.7 x 7.5m	-
No.8 measurement room	-	3.1 x 5.0 x 2.7m	N/A	-
No.9 measurement room	-	8.0 x 4.6 x 2.8m	2.4 x 2.4m	-
No.11 measurement room	-	6.2 x 4.7 x 3.0m	4.8 x 4.6m	-

* Size of vertical conducting plane (for Conducted Emission test): 2.0 x 2.0m for No.1, No.2, No.3, and No.4 semi-anechoic chambers and No.3 and No.4 shielded rooms.

3.6 Test set up, Test data, and Test instruments

Refer to APPENDIX.

SECTION 4: Operation of E.U.T. during testing

4.1 Operating Modes

The mode is used :

Mode	Remarks*
Transmitting mode (Tx) 13.56MHz Mod on	The EUT Transmits and Receives at the same time and there is no receiving mode.
Any condition under the normal use do not exceed the condition of setting. In addition, end users cannot change the settings of the output power of the product.	

Test Item	Operating mode
Conducted emission	Tx without Tag Tx with Tag
Electric Field Strength of Fundamental Emission	Tx without Tag Tx with Tag
Spectrum Mask	Tx without Tag Tx with Tag
20dB Bandwidth	Tx without Tag Tx with Tag
Electric Field Strength of Spurious Emission	Tx without Tag Tx with Tag
Frequency Tolerance	Tx without Tag *1)

*1) After the comparison of the test data between with Tag and without Tag, the tests were performed without Tag which was the worst case.

Justification: The system was configured in typical fashion (as a customer would normally use it) for testing.

Frequency Tolerance:

Temperature : -30deg.C to +50deg.C Step 10deg.C (-30deg.C: Reference)
Voltage : Normal Voltage DC 5 V
Maximum Voltage DC 5.75 V
Minimum Voltage DC 4.25 V

*This EUT provides stable voltage (DC 3.6 V) constantly to RF Part regardless of input voltage.

UL Japan, Inc.

Ise EMC Lab.

4383-326 Asama-cho, Ise-shi, Mie-ken 516-0021 JAPAN

Telephone : +81 596 24 8999

Facsimile : +81 596 24 8124

4.2 Configuration and peripherals

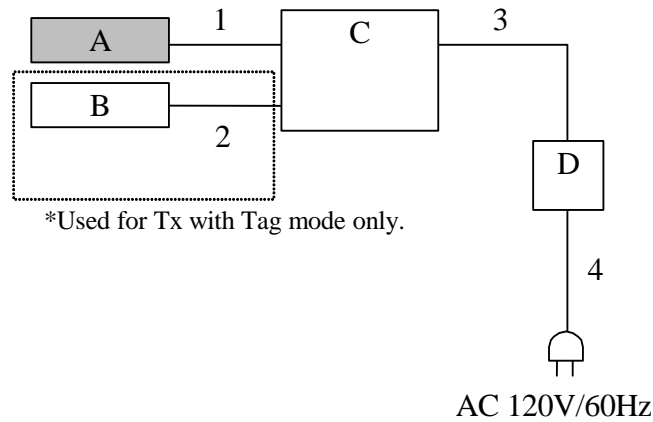

- * Cabling and setup were taken into consideration and test data was taken under worse case conditions.
- * Changed the Tag side to Type A, B, F by using software, and the test was performed as the Tag of actual use.

Description of EUT and Support equipment

No.	Item	Model number	Serial number	Manufacturer	Remark
A	UNIT ASSY, NFC	GHW-H003	0076	OMRON Automotive Electronics Co. Ltd.	EUT
B	UNIT ASSY, NFC (Tag)	TypeA (106kbps)	0075	OMRON Automotive Electronics Co. Ltd.	-
		TypeB (106kbps)			
		TypeF (212kbps/424kbps)			
C	Laptop PC	CF-N8	OBKSA08725	Panasonic	-
D	AC Adapter	CF-AA6372B	6372BM610701051E	Panasonic	-

List of cables used

No.	Name	Length (m)	Shield		Remark
			Cable	Connector	
1	USB Cable	3.5	Shielded	Shielded	-
2	USB Cable	3.5	Shielded	Shielded	-
3	DC Cable	1.0	Unshielded	Unshielded	-
4	AC Cable	1.0	Unshielded	Unshielded	-

UL Japan, Inc.

Ise EMC Lab.

4383-326 Asama-cho, Ise-shi, Mie-ken 516-0021 JAPAN

Telephone : +81 596 24 8999

Facsimile : +81 596 24 8124

SECTION 5: Conducted emission

Test Procedure and conditions

EUT was placed on a urethane platform of nominal size, 1.0 m by 1.5 m, raised 0.8 m above the conducting ground plane. The rear of tabletop was located 40 cm to the vertical conducting plane. The rear of EUT, including peripherals aligned and flushed with rear of tabletop. All other surfaces of tabletop were at least 80 cm from any other grounded conducting surface. EUT was located 80 cm from a Line Impedance Stabilization Network (LISN)/ Artificial mains Network (AMN) and excess AC cable was bundled in center.

For the tests on EUT with other peripherals (as a whole system)

I/O cables that were connected to the peripherals were bundled in center. They were folded back and forth forming a bundle 30 cm to 40 cm long and were hanged at a 40 cm height to the ground plane. All unused 50 ohm connectors of the LISN (AMN) were resistivity terminated in 50 ohm when not connected to the measuring equipment.

The AC Mains Terminal Continuous disturbance Voltage has been measured with the EUT in a Semi Anechoic Chamber. The EUT was connected to a LISN (AMN).

An overview sweep with peak detection has been performed.

The test results and limit are rounded off to one decimal place, so some differences might be observed.

Detector	: QP and CISPR AV
Measurement range	: 0.15 MHz - 30 MHz
Test data	: APPENDIX
Test result	: Pass

SECTION 6: Radiated emission (Fundamental , Spurious Emission and Spectrum Mask)

Test Procedure

[For below 1GHz]

EUT was placed on a urethane platform of nominal size, 0.5 m by 1.0 m, raised 0.8 m above the conducting ground plane. The Radiated Electric Field Strength has been measured in a Semi Anechoic Chamber with a ground plane.

[For above 1GHz]

EUT was placed on a urethane platform of nominal size, 0.5 m by 0.5 m, raised 1.5 m above the conducting ground plane. The Radiated Electric Field Strength has been measured in a Semi Anechoic Chamber with absorbent materials lined on a ground plane.

Frequency: From 9 kHz to 30 MHz

The EUT was rotated a full revolution in order to obtain the maximum value of the electric field intensity.

The measurements were performed for vertical polarization (antenna angle: 0 deg., 45 deg., 90 deg., and 135 deg.) and horizontal polarization.

*Refer to Figure 1 about Direction of the Loop Antenna.

Frequency: From 30 MHz to 1 GHz

The measuring antenna height varied between 1 and 4 m and EUT was rotated a full revolution in order to obtain the maximum value of the electric field intensity.

The measurements were performed for both vertical and horizontal antenna polarization.

The test was made with the detector (RBW/VBW) in the following table.

When using Spectrum analyzer, the test was made with adjusting span to zero by using peak hold.

Test Antennas are used as below;

Frequency	Below 30 MHz	30 MHz to 200 MHz	200 MHz to 1 GHz
Antenna Type	Loop	Biconical	Logperiodic

Frequency	From 9 kHz to 90 kHz and From 110 kHz to 150 kHz	From 90 kHz to 110 kHz	From 150 kHz to 490 kHz	From 490 kHz to 30 MHz	From 30 MHz to 1 GHz
Instrument used	Test Receiver				
Detector	PK / AV	QP	PK / AV	QP	QP
IF Bandwidth	200 Hz	200 Hz	9 kHz	9 kHz	120 kHz
Test Distance	3 m *1)	3 m *1)	3 m *1)	3 m *2)	3 m

*1) Distance Factor: $40 \times \log(3 \text{ m} / 300 \text{ m}) = -80 \text{ dB}$

*2) Distance Factor: $40 \times \log(3 \text{ m} / 30 \text{ m}) = -40 \text{ dB}$

Although these tests were performed other than open field test site, adequate comparison measurements were confirmed against 30 m open field test site. Therefore sufficient tests were made to demonstrate that the alternative site produces results that correlate with the ones of tests made in an open field based on KDB 937606.

These tests were performed in semi anechoic chamber. Therefore the measured level of emissions may be higher than if measurements were made without a ground plane.

However test results were confirmed to pass against standard limit.

- The carrier level and noise levels were confirmed at each position of X, Y and Z axes of EUT to see the position of maximum noise, and the test was made at the position that has the maximum noise.

The test results and limit are rounded off to one decimal place, so some differences might be observed.

Measurement range : 9 kHz - 1 GHz

Test data : APPENDIX 1

Test result : Pass

UL Japan, Inc.

Ise EMC Lab.

4383-326 Asama-cho, Ise-shi, Mie-ken 516-0021 JAPAN

Telephone : +81 596 24 8999

Facsimile : +81 596 24 8124

SECTION 7: Other test

Test	Span	RBW	VBW	Sweep	Detector	Trace	Instrument used
20 dB Bandwidth	100 kHz	1 kHz	3 kHz	Auto	Peak	Max Hold	Spectrum Analyzer
99 % Occupied Bandwidth	Enough width to display emission skirts	1 kHz	3 kHz	Auto	Peak	Max Hold *1)	Spectrum Analyzer
Frequency Tolerance	-	-	-	-	-	-	Frequency counter

*1) The measurement was performed with Max Hold since the duty cycle was not 100 %.
Peak hold was applied as Worst-case measurement.

Test data : APPENDIX
Test result : Pass

Figure 1: Direction of the Loop Antenna

Side View (Vertical)

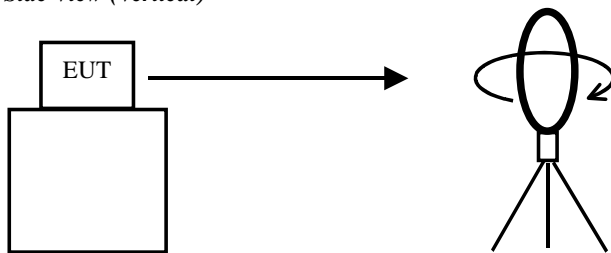

Top View (Horizontal)

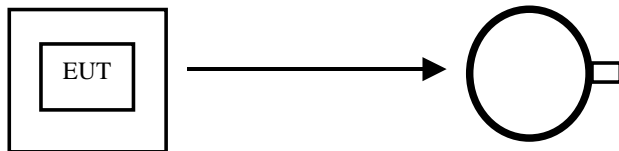

Antenna was not rotated.

Top View (Vertical)

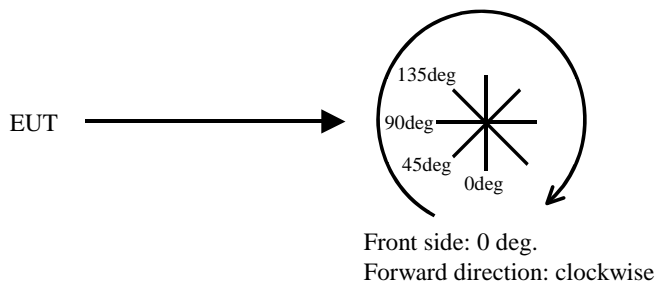

APPENDIX 1: Test data

Conducted emission

DATA OF CONDUCTED EMISSION TEST

UL Japan, Inc. Ise EMC Lab. No.2 Semi Anechoic Chamber
Date : 2017/01/15

Report No. : 11421068H

Temp./Humi. : 20deg. C / 34% RH
Engineer : Ken Fujita

Mode / Remarks : Tx 13.56MHz With tag TypeA

LIMIT : FCC15.207 QP
FCC15.207 AV

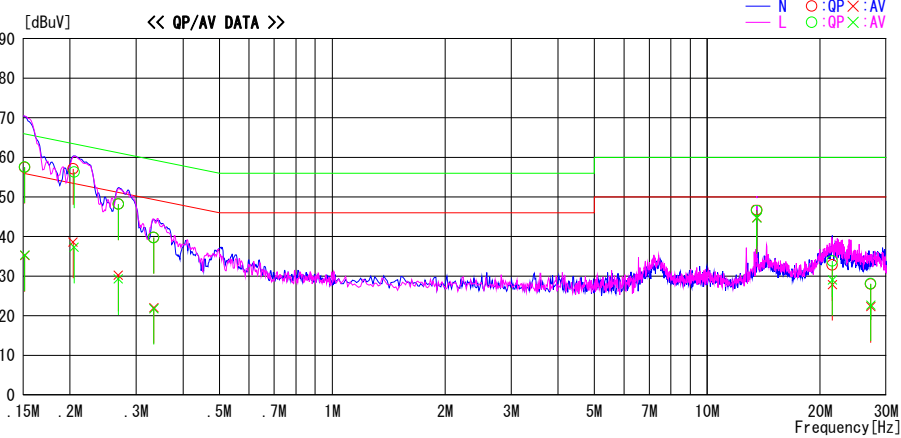

Frequency [MHz]	Reading Level		Corr. Factor [dB]	Results		Limit		Margin		Phase	Comment
	QP [dBuV]	AV [dBuV]		QP [dBuV]	AV [dBuV]	QP [dBuV]	AV [dBuV]	QP [dB]	AV [dB]		
0.15145	44.3	22.0	13.2	57.5	35.2	65.9	55.9	8.4	20.7	N	
0.15145	44.4	22.1	13.2	57.6	35.3	65.9	55.9	8.3	20.6	L	
0.20365	43.9	25.4	13.2	57.1	38.6	63.5	53.5	6.4	14.9	N	
0.20510	43.1	24.1	13.2	56.3	37.3	63.4	53.4	7.1	16.1	L	
0.26890	35.0	17.0	13.2	48.2	30.2	61.2	51.2	13.0	21.0	N	
0.26890	35.0	16.1	13.2	48.2	29.3	61.2	51.2	13.0	21.9	L	
0.33415	26.5	8.9	13.2	39.7	22.1	59.3	49.3	19.6	27.2	N	
0.33415	26.5	8.6	13.2	39.7	21.8	59.3	49.3	19.6	27.5	L	
13.56000	32.1	30.2	14.5	46.6	44.7	60.0	50.0	13.4	5.3	L	
13.56000	32.2	30.3	14.5	46.7	44.8	60.0	50.0	13.3	5.2	N	
21.54561	18.8	14.1	15.0	33.8	29.1	60.0	50.0	26.2	20.9	L	
21.54561	17.8	12.9	15.0	32.8	27.9	60.0	50.0	27.2	22.1	N	
27.29329	12.8	7.1	15.2	28.0	22.3	60.0	50.0	32.0	27.7	N	
27.29329	12.9	7.5	15.2	28.1	22.7	60.0	50.0	31.9	27.3	L	

CHART: WITH FACTOR, Peak hold data. CALCULATION: RESULT [dBuV]=READING [dBuV]+C. F [dB] (LISN + ATTEN + CABLE)
Except for the above table : adequate margin data below the limits.

Conducted emission

DATA OF CONDUCTED EMISSION TEST

UL Japan, Inc. Ise EMC Lab. No.2 Semi Anechoic Chamber
Date : 2017/01/15

Report No. : 11421068H

Temp./Humi. : 20deg. C / 34% RH
Engineer : Ken Fujita

Mode / Remarks : Tx 13.56MHz With tag TypeB

LIMIT : FCC15.207 QP
FCC15.207 AV

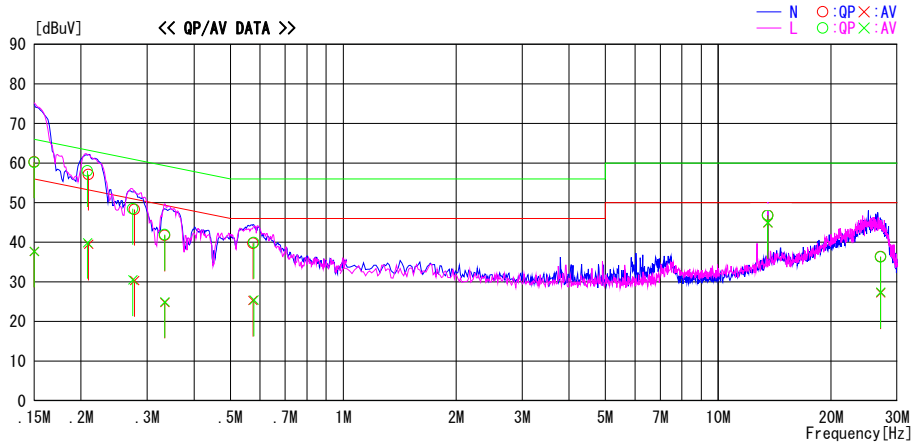

Frequency [MHz]	Reading		Corr. Factor	Results		Limit		Margin		Phase	Comment
	QP [dBuV]	AV [dBuV]		QP [dBuV]	AV [dBuV]	QP [dBuV]	AV [dBuV]	QP [dB]	AV [dB]		
0.15000	47.1	24.5	13.2	60.3	37.7	66.0	56.0	5.7	18.3	N	
0.15000	47.0	24.5	13.2	60.2	37.7	66.0	56.0	5.8	18.3	L	
0.20800	44.8	26.7	13.2	58.0	39.9	63.3	53.3	5.3	13.4	L	
0.20945	43.9	26.3	13.2	57.1	39.5	63.2	53.2	6.1	13.7	N	
0.27470	35.3	17.3	13.2	48.5	30.5	61.0	51.0	12.5	20.5	L	
0.27760	35.1	17.1	13.2	48.3	30.3	60.9	50.9	12.6	20.6	N	
0.33415	28.5	11.6	13.2	41.7	24.8	59.3	49.3	17.6	24.5	N	
0.33415	28.7	11.8	13.2	41.9	25.0	59.3	49.3	17.4	24.3	L	
0.57485	26.4	12.0	13.3	39.7	25.3	56.0	46.0	16.3	20.7	N	
0.57775	26.6	12.1	13.3	39.9	25.4	56.0	46.0	16.1	20.6	L	
13.56000	32.2	30.5	14.5	46.7	45.0	60.0	50.0	13.3	5.0	L	
13.56000	32.3	30.4	14.5	46.8	44.9	60.0	50.0	13.2	5.1	N	
27.12000	21.1	12.2	15.2	36.3	27.4	60.0	50.0	23.7	22.6	L	
27.12621	21.2	12.0	15.2	36.4	27.2	60.0	50.0	23.6	22.8	N	

CHART:WITH FACTOR,Peak hold data. CALCULATION:RESULT[dBuV]=READING[dBuV]+C.F[dB](LISN + ATTEN + CABLE)
Except for the above table : adequate margin data below the limits.

Conducted emission

DATA OF CONDUCTED EMISSION TEST

UL Japan, Inc. Ise EMC Lab. No.2 Semi Anechoic Chamber
Date : 2017/01/15

Report No. : 11421068H
Temp./Humi. : 20deg. C / 34% RH
Engineer : Ken Fujita

Mode / Remarks : Tx 13.56MHz With tag TypeF(212kbps)

LIMIT : FCC15.207 QP
FCC15.207 AV

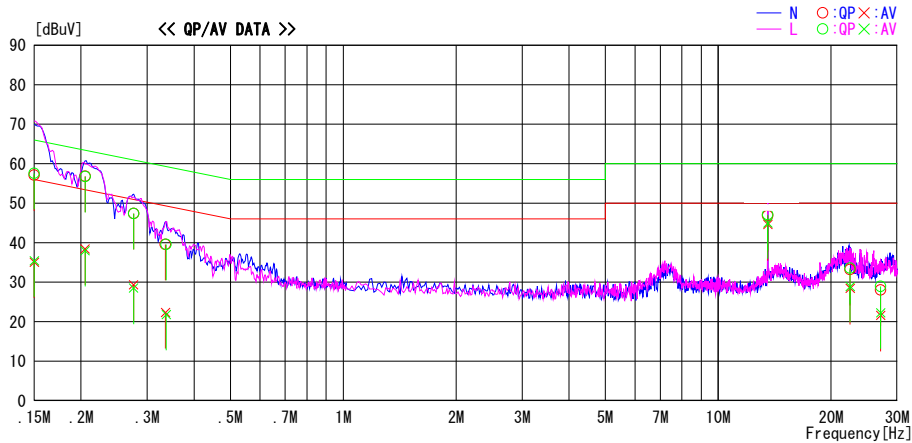

Frequency [MHz]	Reading Level		Corr. Factor [dB]	Results		Limit		Margin		Phase	Comment
	QP [dBuV]	AV [dBuV]		QP [dBuV]	AV [dBuV]	QP [dBuV]	AV [dBuV]	QP [dB]	AV [dB]		
0.15000	43.9	21.9	13.2	57.1	35.1	66.0	56.0	8.9	20.9	N	
0.15000	44.4	22.2	13.2	57.6	35.4	66.0	56.0	8.4	20.6	L	
0.20510	43.6	25.2	13.2	56.8	38.4	63.4	53.4	6.6	15.0	N	
0.20510	43.5	24.8	13.2	56.7	38.0	63.4	53.4	6.7	15.4	L	
0.27615	34.2	16.1	13.2	47.4	29.3	60.9	50.9	13.5	21.6	N	
0.27615	34.2	15.3	13.2	47.4	28.5	60.9	50.9	13.5	22.4	L	
0.33560	26.4	9.1	13.2	39.6	22.3	59.3	49.3	19.7	27.0	N	
0.33705	26.4	8.6	13.2	39.6	21.8	59.3	49.3	19.7	27.5	L	
13.56000	32.6	30.5	14.5	47.1	45.0	60.0	50.0	12.9	5.0	L	
13.56000	32.3	30.1	14.5	46.8	44.6	60.0	50.0	13.2	5.4	N	
22.48128	18.2	13.4	15.0	33.2	28.4	60.0	50.0	26.8	21.6	N	
22.48128	18.6	13.9	15.0	33.6	28.9	60.0	50.0	26.4	21.1	L	
27.12000	12.8	6.4	15.2	28.0	21.6	60.0	50.0	32.0	28.4	N	
27.12000	13.7	7.0	15.2	28.9	22.2	60.0	50.0	31.1	27.8	L	

CHART: WITH FACTOR, Peak hold data. CALCULATION: RESULT [dBuV]=READING [dBuV]+C. F [dB] (LISN + ATTN + CABLE)
Except for the above table : adequate margin data below the limits.

Conducted emission

DATA OF CONDUCTED EMISSION TEST

UL Japan, Inc. Ise EMC Lab. No.2 Semi Anechoic Chamber
Date : 2017/01/15

Report No. : 11421068H

Temp./Humi. : 20deg. C / 34% RH
Engineer : Ken Fujita

Mode / Remarks : Tx 13.56MHz With tag TypeF(424kbps)

LIMIT : FCC15.207 QP
FCC15.207 AV

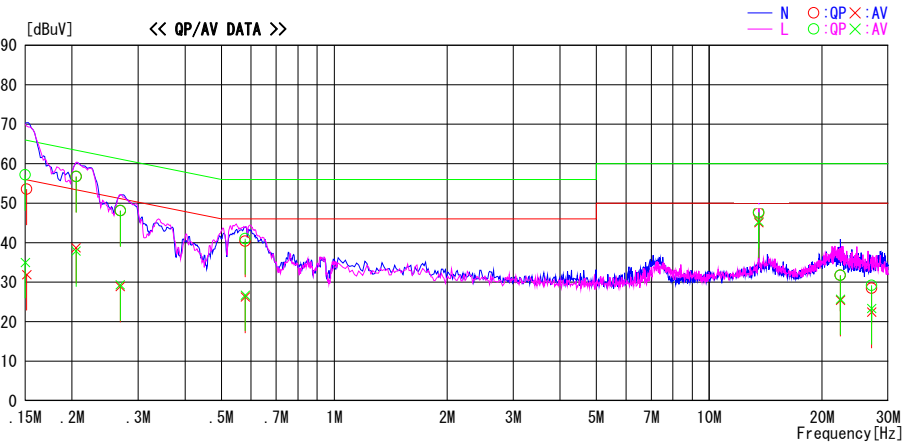

Frequency [MHz]	Reading Level		Corr. Factor [dB]	Results		Limit		Margin		Phase	Comment
	QP [dBuV]	AV [dBuV]		QP [dBuV]	AV [dBuV]	QP [dBuV]	AV [dBuV]	QP [dB]	AV [dB]		
0.15000	44.0	21.8	13.2	57.2	35.0	66.0	56.0	8.8	21.0	L	
0.15145	40.4	18.7	13.2	53.6	31.9	65.9	55.9	12.3	24.0	N	
0.20510	43.5	25.5	13.2	56.7	38.7	63.4	53.4	6.7	14.7	N	
0.20510	43.5	24.7	13.2	56.7	37.9	63.4	53.4	6.7	15.5	L	
0.26890	34.9	15.7	13.2	48.1	28.9	61.2	51.2	13.1	22.3	N	
0.26890	34.9	16.1	13.2	48.1	29.3	61.2	51.2	13.1	21.9	L	
0.57920	27.1	12.9	13.3	40.4	26.2	56.0	46.0	15.6	19.8	N	
0.57920	27.7	13.4	13.3	41.0	26.7	56.0	46.0	15.0	19.3	L	
13.56000	33.2	30.8	14.5	47.7	45.3	60.0	50.0	12.3	4.7	L	
13.56000	33.0	30.6	14.5	47.5	45.1	60.0	50.0	12.5	4.9	N	
22.38103	16.7	10.7	15.0	31.7	25.7	60.0	50.0	28.3	24.3	L	
22.38103	16.7	10.4	15.0	31.7	25.4	60.0	50.0	28.3	24.6	N	
27.12000	13.3	7.2	15.2	28.5	22.4	60.0	50.0	31.5	27.6	N	
27.12000	14.0	8.1	15.2	29.2	23.3	60.0	50.0	30.8	26.7	L	

CHART:WITH FACTOR, Peak hold data. CALCULATION: RESULT [dBuV]=READING [dBuV]+C. F [dB] (LISN + ATTEN + CABLE)
Except for the above table : adequate margin data below the limits.

Conducted emission

DATA OF CONDUCTED EMISSION TEST

UL Japan, Inc. Ise EMC Lab. No.2 Semi Anechoic Chamber
Date : 2017/01/15

Report No. : 11421068H
Temp./Humi. : 20deg. C / 34% RH
Engineer : Ken Fujita

Mode / Remarks : Tx 13.56MHz Without tag TypeA

LIMIT : FCC15.207 QP
FCC15.207 AV

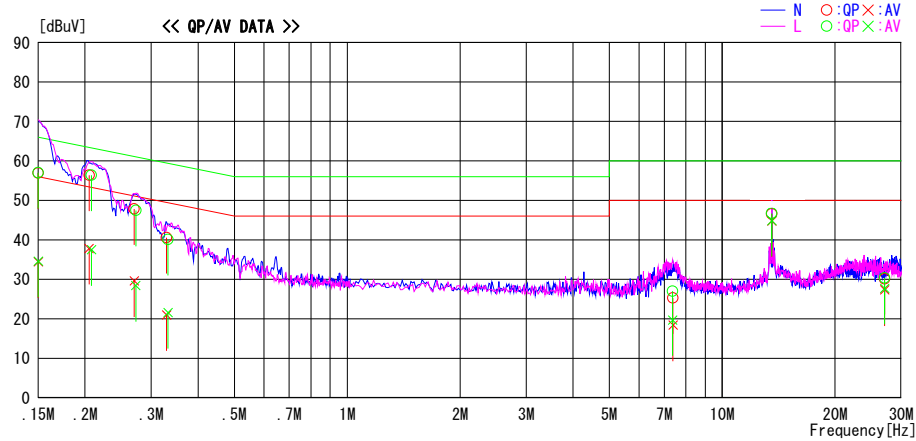

Frequency [MHz]	Reading_Level		Corr. Factor	Results		Limit		Margin		Phase	Comment
	QP [dBuV]	AV [dBuV]		QP [dBuV]	AV [dBuV]	QP [dBuV]	AV [dBuV]	QP [dB]	AV [dB]		
0.15000	43.7	21.2	13.2	56.9	34.4	66.0	56.0	9.1	21.6	N	
0.15000	43.8	21.4	13.2	57.0	34.6	66.0	56.0	9.0	21.4	L	
0.20510	43.2	24.6	13.2	56.4	37.8	63.4	53.4	7.0	15.6	N	
0.20800	43.2	24.3	13.2	56.4	37.5	63.3	53.3	6.9	15.8	L	
0.27035	34.6	16.4	13.2	47.8	29.6	61.1	51.1	13.3	21.5	N	
0.27325	34.3	15.2	13.2	47.5	28.4	61.0	51.0	13.5	22.6	L	
0.32880	27.4	7.8	13.2	40.6	21.0	59.5	49.5	18.9	28.5	N	
0.33270	26.9	8.4	13.2	40.1	21.6	59.4	49.4	19.3	27.8	L	
7.37436	13.0	5.7	14.0	27.0	19.7	60.0	50.0	33.0	30.3	L	
13.56000	32.2	30.4	14.5	46.7	44.9	60.0	50.0	13.3	5.1	L	
7.38948	11.3	4.4	14.0	25.3	18.4	60.0	50.0	34.7	31.6	N	
13.56000	32.1	30.3	14.5	46.6	44.8	60.0	50.0	13.4	5.2	N	
27.12000	14.9	12.1	15.2	30.1	27.3	60.0	50.0	29.9	22.7	N	
27.12000	15.2	12.5	15.2	30.4	27.7	60.0	50.0	29.6	22.3	L	

CHART: WITH FACTOR, Peak hold data. CALCULATION: RESULT[dBuV]=READING[dBuV]+C.F[dB] (LISN + ATTEN + CABLE)
Except for the above table : adequate margin data below the limits.

Conducted emission

DATA OF CONDUCTED EMISSION TEST

UL Japan, Inc. Ise EMC Lab. No.2 Semi Anechoic Chamber
Date : 2017/01/15

Report No. : 11421068H
Temp./Humi. : 20deg. C / 34% RH
Engineer : Ken Fujita

Mode / Remarks : Tx 13.56MHz Without tag TypeB

LIMIT : FCC15.207 QP
FCC15.207 AV

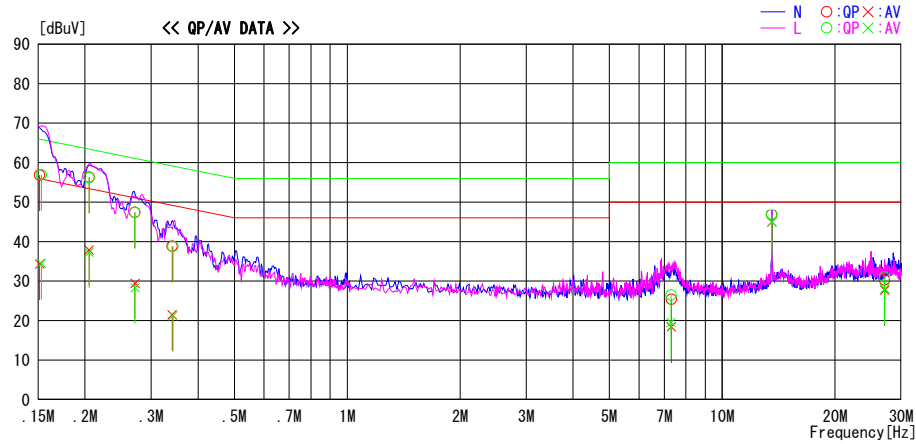

Frequency [MHz]	Reading Level		Corr. Factor [dB]	Results		Limit		Margin		Phase	Comment
	QP [dBuV]	AV [dBuV]		QP [dBuV]	AV [dBuV]	QP [dBuV]	AV [dBuV]	QP [dB]	AV [dB]		
0.15145	43.6	21.1	13.2	56.8	34.3	65.9	55.9	9.1	21.6	N	
0.15290	43.7	21.3	13.2	56.9	34.5	65.8	55.8	8.9	21.3	L	
0.20510	43.1	24.7	13.2	56.3	37.9	63.4	53.4	7.1	15.5	N	
0.20510	43.0	24.1	13.2	56.2	37.3	63.4	53.4	7.2	16.1	L	
0.27180	34.2	16.2	13.2	47.4	29.4	61.1	51.1	13.7	21.7	N	
0.27180	34.2	15.1	13.2	47.4	28.3	61.1	51.1	13.7	22.8	L	
0.34140	25.6	8.3	13.2	38.8	21.5	59.2	49.2	20.4	27.7	N	
0.34285	25.5	8.0	13.2	38.7	21.2	59.1	49.1	20.4	27.9	L	
7.29878	12.5	5.5	14.0	26.5	19.5	60.0	50.0	33.5	30.5	L	
13.56000	32.4	30.5	14.5	46.9	45.0	60.0	50.0	13.1	5.0	L	
7.31389	11.4	4.4	14.0	25.4	18.4	60.0	50.0	34.6	31.6	N	
13.56000	32.3	30.5	14.5	46.8	45.0	60.0	50.0	13.2	5.0	N	
27.12000	15.1	12.5	15.2	30.3	27.7	60.0	50.0	29.7	22.3	N	
27.12000	15.8	12.9	15.2	31.0	28.1	60.0	50.0	29.0	21.9	L	

CHART:WITH FACTOR, Peak hold data. CALCULATION: RESULT [dBuV]=READING [dBuV]+C. F [dB] (LISN + ATTEN + CABLE)
Except for the above table : adequate margin data below the limits.

Conducted emission

DATA OF CONDUCTED EMISSION TEST

UL Japan, Inc. Ise EMC Lab. No.2 Semi Anechoic Chamber
Date : 2017/01/15

Report No. : 11421068H

Temp./Humi. : 20deg. C / 34% RH
Engineer : Ken Fujita

Mode / Remarks : Tx 13.56MHz Without tag TypeF(212kbps)

LIMIT : FCC15.207 QP
FCC15.207 AV

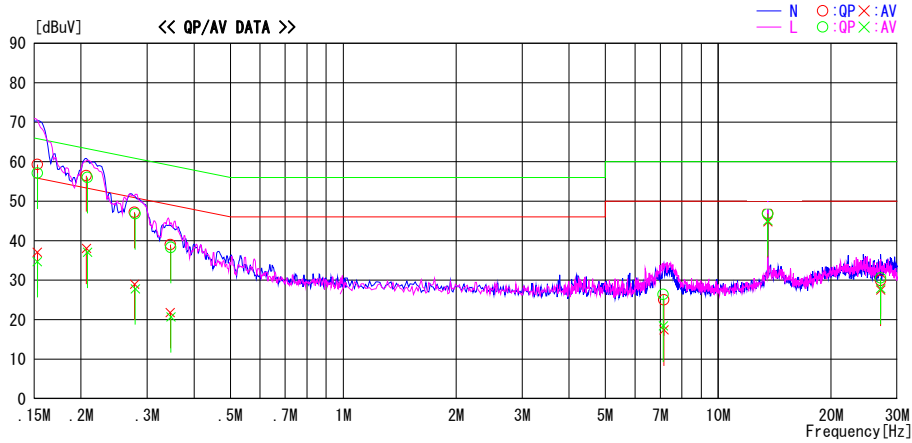

Frequency [MHz]	Reading Level		Corr. Factor [dB]	Results		Limit		Margin		Phase	Comment
	QP [dBuV]	AV [dBuV]		QP [dBuV]	AV [dBuV]	QP [dBuV]	AV [dBuV]	QP [dB]	AV [dB]		
0.15290	46.1	23.9	13.2	59.3	37.1	65.8	55.8	6.5	18.7	N	
0.15290	43.9	21.5	13.2	57.1	34.7	65.8	55.8	8.7	21.1	L	
0.20655	43.3	24.9	13.2	56.5	38.1	63.3	53.3	6.8	15.2	N	
0.20800	42.8	23.9	13.2	56.0	37.1	63.3	53.3	7.3	16.2	L	
0.27760	34.0	15.8	13.2	47.2	29.0	60.9	50.9	13.7	21.9	N	
0.27905	33.6	14.6	13.2	46.8	27.8	60.8	50.8	14.0	23.0	L	
0.34575	25.8	8.6	13.2	39.0	21.8	59.1	49.1	20.1	27.3	N	
0.34720	25.1	7.5	13.2	38.3	20.7	59.0	49.0	20.7	28.3	L	
7.13249	12.4	4.4	14.0	26.4	18.4	60.0	50.0	33.6	31.6	L	
13.56000	32.2	30.6	14.5	46.7	45.1	60.0	50.0	13.3	4.9	L	
7.16273	11.0	3.4	14.0	25.0	17.4	60.0	50.0	35.0	32.6	N	
13.56000	32.4	30.3	14.5	46.9	44.8	60.0	50.0	13.1	5.2	N	
27.12000	14.7	12.3	15.2	29.9	27.5	60.0	50.0	30.1	22.5	N	
27.12000	15.4	12.7	15.2	30.6	27.9	60.0	50.0	29.4	22.1	L	

CHART:WITH FACTOR, Peak hold data. CALCULATION: RESULT [dBuV]=READING [dBuV]+C. F [dB] (LISN + ATTN + CABLE)
Except for the above table : adequate margin data below the limits.

Conducted emission

DATA OF CONDUCTED EMISSION TEST

UL Japan, Inc. Ise EMC Lab. No.2 Semi Anechoic Chamber
Date : 2017/01/15

Report No. : 11421068H

Temp./Humi. : 20deg. C / 34% RH
Engineer : Ken Fujita

Mode / Remarks : Tx 13.56MHz Without tag TypeF (424kbps)

LIMIT : FCC15.207 QP
FCC15.207 AV

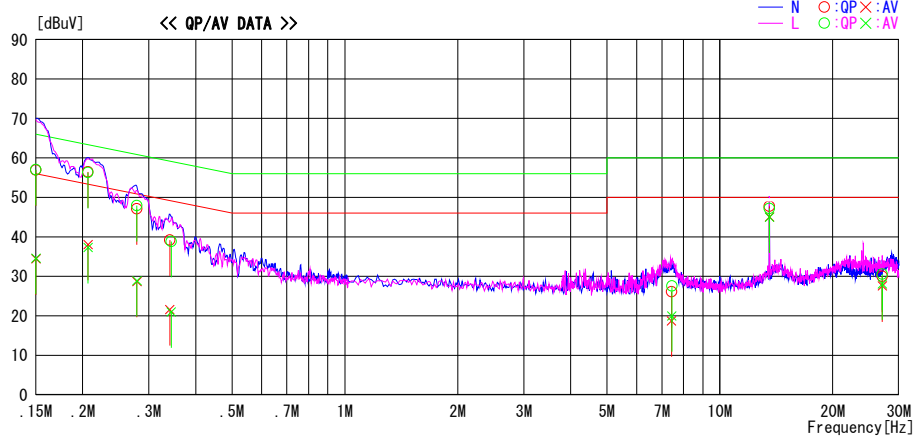

Frequency [MHz]	Reading Level		Corr. Factor [dB]	Results		Limit		Margin		Phase	Comment
	QP [dBuV]	AV [dBuV]		QP [dBuV]	AV [dBuV]	QP [dBuV]	AV [dBuV]	QP [dB]	AV [dB]		
0.15000	43.7	21.2	13.2	56.9	34.4	66.0	56.0	9.1	21.6	N	
0.15000	43.8	21.4	13.2	57.0	34.6	66.0	56.0	9.0	21.4	L	
0.20655	43.3	24.9	13.2	56.5	38.1	63.3	53.3	6.8	15.2	N	
0.20655	43.1	24.1	13.2	56.3	37.3	63.3	53.3	7.0	16.0	L	
0.27905	33.9	15.5	13.2	47.1	28.7	60.8	50.8	13.7	22.1	N	
0.27905	34.7	15.7	13.2	47.9	28.9	60.8	50.8	12.9	21.9	L	
0.34140	26.0	8.4	13.2	39.2	21.6	59.2	49.2	20.0	27.6	N	
0.34430	25.6	7.8	13.2	38.8	21.0	59.1	49.1	20.3	28.1	L	
7.43483	12.1	4.7	14.0	26.1	18.7	60.0	50.0	33.9	31.3	N	
7.44994	13.6	6.0	14.0	27.6	20.0	60.0	50.0	32.4	30.0	L	
13.56000	32.7	30.5	14.5	47.2	45.0	60.0	50.0	12.8	5.0	L	
13.56000	33.2	30.6	14.5	47.7	45.1	60.0	50.0	12.3	4.9	N	
27.12000	14.8	12.4	15.2	30.0	27.6	60.0	50.0	30.0	22.4	N	
27.12000	15.4	12.9	15.2	30.6	28.1	60.0	50.0	29.4	21.9	L	

CHART: WITH FACTOR, Peak hold data. CALCULATION: RESULT[dBuV]=READING[dBuV]+C.F[dB] (LISN + ATTEN + CABLE)
Except for the above table : adequate margin data below the limits.

Fundamental emission and Spectrum Mask

DATA OF RADIATED EMISSION TEST

UL Japan, Inc. Ise EMC Lab. No.4 Semi Anechoic Chamber
Date : 2016/01/05

Report No. : 11421068H
Temp./Humi. : 25deg. C / 30% RH
Engineer : Ken Fujita

Mode / Remarks : Tx 13.56MHz With tag TypeA Worst Axis X

Limit1 : FCC15.225_PKQP, 9-90kHz:PK, 110-490kHz:PK, other:QP
Limit2 : FCC15.225_AVQP, 9-90kHz:AV, 110-490kHz:AV, other:QP

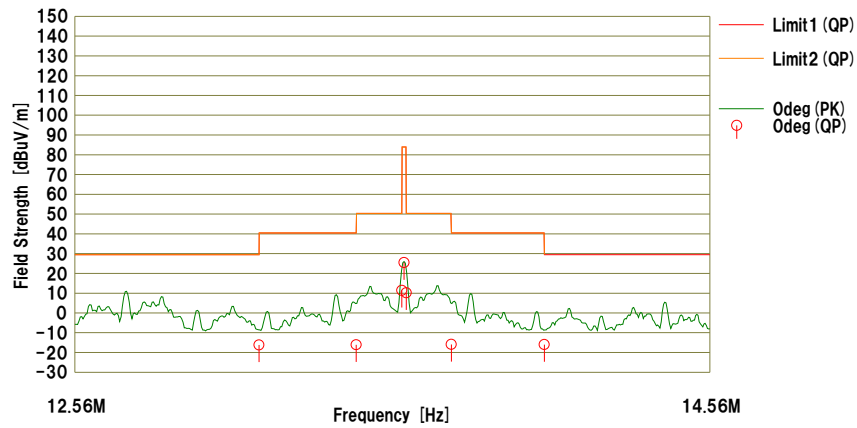

No.	Freq. [MHz]	Reading	AntFac [dB/m]	Loss [dB]	Gain [dB]	Result	Limit		Margin		Antenna [deg]	Table [deg]	Comment
		[dBuV]				[dBuV/m]	[dBuV/m]	[dB]	[dB]	[dB]			
1	13.11000	29.6	19.4	-33.1	32.1	-16.2	29.5	29.5	45.7	45.7	Odeg	96	
2	13.41000	29.7	19.4	-33.1	32.1	-16.1	40.5	40.5	56.6	56.6	Odeg	96	
3	13.55300	57.1	19.4	-33.0	32.1	11.4	50.4	50.4	39.0	39.0	Odeg	96	
4	13.56000	71.2	19.4	-33.0	32.1	25.5	83.9	83.9	58.4	58.4	Odeg	96	
5	13.56700	55.9	19.4	-33.0	32.1	10.2	50.4	50.4	40.2	40.2	Odeg	96	
6	13.71000	29.8	19.4	-33.0	32.1	-15.9	40.5	40.5	56.4	56.4	Odeg	96	
7	14.01000	29.7	19.4	-33.0	32.1	-16.0	29.5	29.5	45.5	45.5	Odeg	96	

CHART:WITH FACTOR Peak hold data.CALCULATION : RESULT = READING + ANT FACTOR + LOSS (CABLE + ATTEN) - GAIN(AMP) + D. FACTOR
Except for the above table : adequate margin data below the limits.

Result of the fundamental emission at 3 m without Distance factor

QP

Ant Deg [deg]	Frequency [MHz]	Detector	Reading [dBuV]	Ant Factor [dB/m]	Loss [dB]	Gain [dB]	Duty Factor [dB]	Result [dBuV/m]	Limit [dBuV/m]	Margin [dB]	Remark
0	13.56000	QP	71.2	19.4	7.0	32.1	-	65.5	-	-	Fundamental

Result = Reading + Ant Factor + Loss (Cable+Attenuator+Filter) - Gain(Amplifier)

Fundamental emission and Spectrum Mask

DATA OF RADIATED EMISSION TEST

UL Japan, Inc. Ise EMC Lab. No.4 Semi Anechoic Chamber
Date : 2016/01/05

Report No. : 11421068H
Temp./Humi. : 25deg. C / 30% RH
Engineer : Ken Fujita

Mode / Remarks : Tx 13.56MHz With tag TypeB Worst Axis X
Limit1 : FCC15_225_PKQP, 9-90kHz:PK, 110-490kHz:PK, other:QP

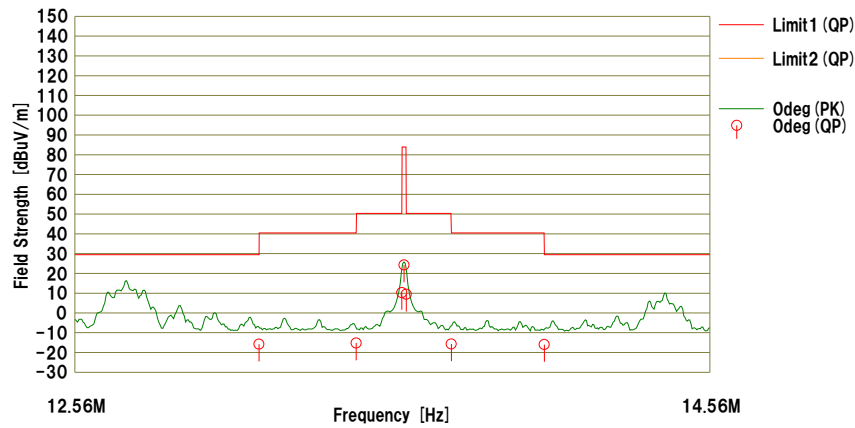

No.	Freq. [MHz]	Reading	AntFac [dB/m]	Loss [dB]	Gain [dB]	Result	Limit		Margin		Antenna [deg]	Table [deg]	Comment
		<QP> [dBuV]				<QP> [dBuV/m]	<QP> [dBuV/m]	<QP> [dB]	<QP> [dB]				
1	13.11000	30.0	19.4	-33.0	32.2	-15.8	29.5	---	45.3	---	Odeg	98	
2	13.41000	30.6	19.4	-33.0	32.2	-15.2	40.5	---	55.7	---	Odeg	98	
3	13.55300	56.1	19.4	-33.0	32.2	10.3	50.4	---	40.1	---	Odeg	98	
4	13.56000	70.0	19.4	-33.0	32.2	24.2	83.9	---	59.7	---	Odeg	98	
5	13.56700	55.2	19.4	-33.0	32.2	9.4	50.4	---	41.0	---	Odeg	98	
6	13.71000	30.1	19.4	-33.0	32.2	-15.7	40.5	---	56.2	---	Odeg	98	
7	14.01000	29.8	19.4	-33.0	32.2	-16.0	29.5	---	45.5	---	Odeg	98	

CHART:WITH FACTOR Peak hold data.CALCULATION : RESULT = READING + ANT FACTOR + LOSS (CABLE + ATTEN) - GAIN (AMP) + D. FACTOR
Except for the above table : adequate margin data below the limits.

Result of the fundamental emission at 3 m without Distance factor

QP

Ant Deg [deg]	Frequency [MHz]	Detector	Reading [dBuV]	Ant Factor [dB/m]	Loss [dB]	Gain [dB]	Duty Factor [dB]	Result [dBuV/m]	Limit [dBuV/m]	Margin [dB]	Remark
0	13.56000	QP	70.0	19.4	7.0	32.2	-	64.2	-	-	Fundamental

Result = Reading + Ant Factor + Loss (Cable+Attenuator+Filter) - Gain(Amplifier)

Fundamental emission and Spectrum Mask

DATA OF RADIATED EMISSION TEST

UL Japan, Inc. Ise EMC Lab. No.4 Semi Anechoic Chamber
Date : 2016/01/05

Report No. : 11421068H
Temp./Humi. : 25deg. C / 30% RH
Engineer : Ken Fujita

Mode / Remarks : Tx 13.56MHz With tag TypeF (212kbps) Worst Axis X
Limit1 : FCC15_225_PKQP, 9-90kHz:PK, 110-490kHz:PK, other:QP

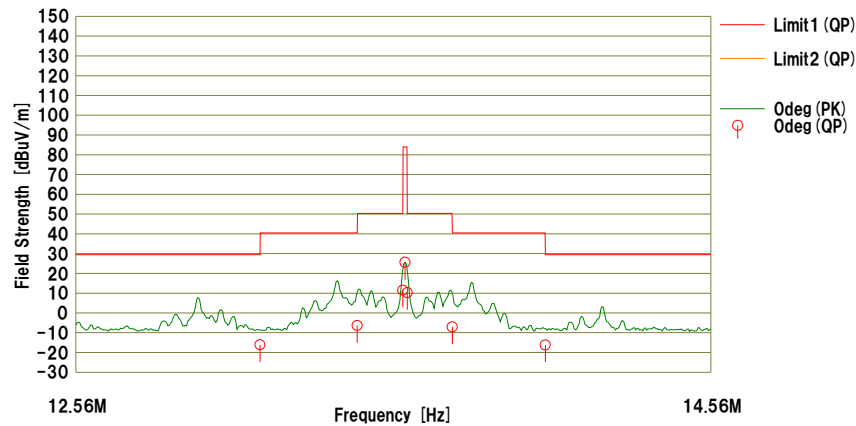

No.	Freq. [MHz]	Reading	AntFac [dB/m]	Loss [dB]	Gain [dB]	Result	Limit		Margin		Antenna [deg]	Table	Comment
		[dBuV]				[dB]	[dBuV/m]	[dBuV/m]	[dB]	[dB]			
1	13.11000	29.7	19.4	-33.0	32.2	-16.1	29.5	---	45.6	---	Odeg	98	
2	13.41000	39.4	19.4	-33.0	32.2	-6.4	40.5	---	46.9	---	Odeg	98	
3	13.55300	57.3	19.4	-33.0	32.2	11.5	50.4	---	38.9	---	Odeg	98	
4	13.56000	71.4	19.4	-33.0	32.2	25.6	83.9	---	58.3	---	Odeg	98	
5	13.56700	56.1	19.4	-33.0	32.2	10.3	50.4	---	40.1	---	Odeg	98	
6	13.71000	38.7	19.4	-33.0	32.2	-7.1	40.5	---	47.6	---	Odeg	98	
7	14.01000	29.6	19.4	-33.0	32.2	-16.2	29.5	---	45.7	---	Odeg	98	

CHART:WITH FACTOR Peak hold data.CALCULATION : RESULT = READING + ANT FACTOR + LOSS (CABLE + ATTEN) - GAIN (AMP) + D. FACTOR
Except for the above table : adequate margin data below the limits.

Result of the fundamental emission at 3 m without Distance factor

QP

Ant Deg [deg]	Frequency [MHz]	Detector	Reading [dBuV]	Ant Factor [dB/m]	Loss [dB]	Gain [dB]	Duty Factor [dB]	Result [dBuV/m]	Limit [dBuV/m]	Margin [dB]	Remark
0	13.56000	QP	71.4	19.4	7.0	32.2	-	65.6	-	-	Fundamental

Result = Reading + Ant Factor + Loss (Cable+Attenuator+Filter) - Gain(Amplifier)

Fundamental emission and Spectrum Mask

DATA OF RADIATED EMISSION TEST

UL Japan, Inc. Ise EMC Lab. No.4 Semi Anechoic Chamber
Date : 2016/01/05

Report No. : 11421068H
Temp./Humi. : 25deg. C / 30% RH
Engineer : Ken Fujita

Mode / Remarks : Tx 13.56MHz With tag TypeF (424kbps) Worst Axis X
Limit1 : FCC15_225_PKQP, 9-90kHz:PK, 110-490kHz:PK, other:QP

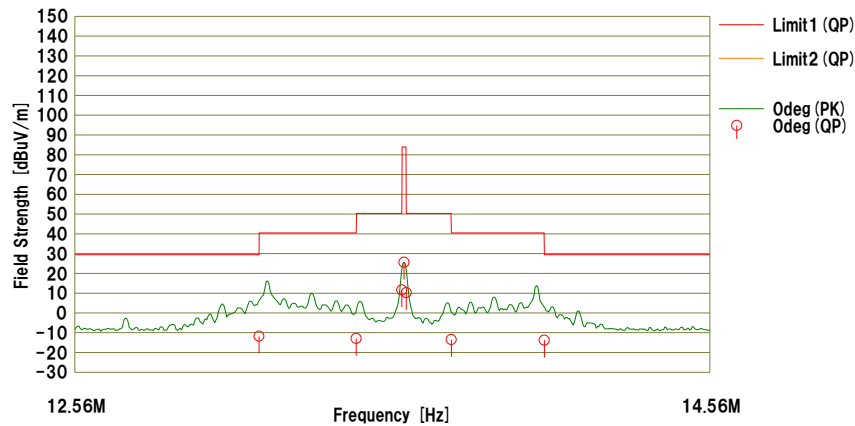

No.	Freq. [MHz]	Reading	AntFac [dB/m]	Loss [dB]	Gain [dB]	Result	Limit		Margin		Antenna	Table	Comment
		<QP> [dBuV]				<QP> [dBuV/m]	<QP> [dBuV/m]	<QP> [dB]	<QP> [dB]				
1	13.11000	34.0	19.4	-33.0	32.2	-11.8	29.5	---	41.3	---	Odeg	97	
2	13.41000	32.9	19.4	-33.0	32.2	-12.9	40.5	---	53.4	---	Odeg	97	
3	13.55300	57.4	19.4	-33.0	32.2	11.6	50.4	---	38.8	---	Odeg	97	
4	13.56000	71.4	19.4	-33.0	32.2	25.6	83.9	---	58.3	---	Odeg	97	
5	13.56700	56.1	19.4	-33.0	32.2	10.3	50.4	---	40.1	---	Odeg	97	
6	13.71000	32.3	19.4	-33.0	32.2	-13.5	40.5	---	54.0	---	Odeg	97	
7	14.01000	32.0	19.4	-33.0	32.2	-13.8	29.5	---	43.3	---	Odeg	97	

CHART:WITH FACTOR Peak hold data.CALCULATION : RESULT = READING + ANT FACTOR + LOSS (CABLE + ATTEN) - GAIN (AMP) + D. FACTOR
Except for the above table : adequate margin data below the limits.

Result of the fundamental emission at 3 m without Distance factor

QP

Ant Deg [deg]	Frequency [MHz]	Detector	Reading [dBuV]	Ant Factor [dB/m]	Loss [dB]	Gain [dB]	Duty Factor [dB]	Result [dBuV/m]	Limit [dBuV/m]	Margin [dB]	Remark
0	13.56000	QP	71.4	19.4	7.0	32.2	-	65.6	-	-	Fundamental

Result = Reading + Ant Factor + Loss (Cable+Attenuator+Filter) - Gain(Amplifier)

Fundamental emission and Spectrum Mask

DATA OF RADIATED EMISSION TEST

UL Japan, Inc. Ise EMC Lab. No.4 Semi Anechoic Chamber
Date : 2016/01/05

Report No. : 11421068H
Temp./Humi. : 25deg. C / 30% RH
Engineer : Ken Fujita

Mode / Remarks : Tx 13.56MHz Without tag TypeA Worst Axis X

Limit1 : FCC15.225_PKQP, 9-90kHz:PK, 110-490kHz:PK, other:QP
Limit2 : FCC15.225_AVQP, 9-90kHz:AV, 110-490kHz:AV, other:QP

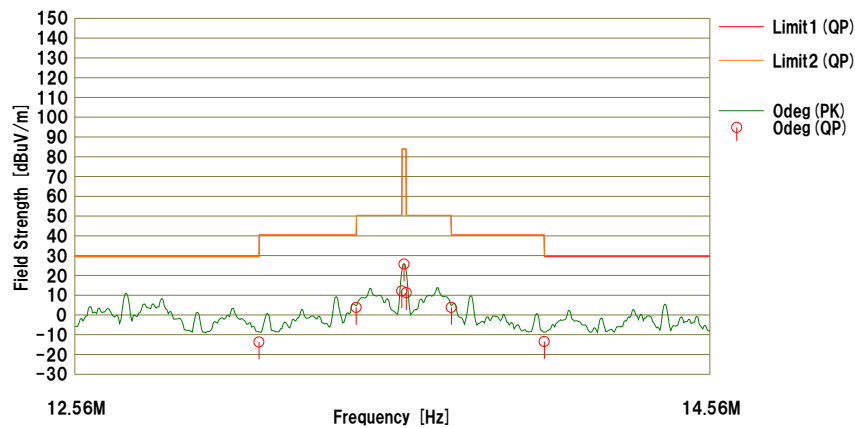

No.	Freq. [MHz]	Reading	AntFac [dB/m]	Loss [dB]	Gain [dB]	Result	Limit		Margin		Antenna [deg]	Table [deg]	Comment
		<QP> [dBuV]				<QP> [dBuV/m]	<QP> [dB]	<QP> [dB]	<QP> [dB]	<QP> [dB]			
1	13.11000	32.1	19.4	-33.1	32.1	-13.7	29.5	29.5	43.2	43.2	Odeg	85	
2	13.41000	49.6	19.4	-33.1	32.1	3.8	40.5	40.5	36.7	36.7	Odeg	85	
3	13.55300	57.8	19.4	-33.0	32.1	12.1	50.4	50.4	38.3	38.3	Odeg	85	
4	13.56000	71.4	19.4	-33.0	32.1	25.7	83.9	83.9	58.2	58.2	Odeg	85	
5	13.56700	56.9	19.4	-33.0	32.1	11.2	50.4	50.4	39.2	39.2	Odeg	85	
6	13.71000	49.5	19.4	-33.0	32.1	3.8	40.5	40.5	36.7	36.7	Odeg	85	
7	14.01000	32.2	19.4	-33.0	32.1	-13.5	29.5	29.5	43.0	43.0	Odeg	85	

CHART:WITH FACTOR Peak hold data.CALCULATION : RESULT = READING + ANT FACTOR + LOSS (CABLE + ATTEN) - GAIN (AMP) + D. FACTOR
Except for the above table : adequate margin data below the limits.

Result of the fundamental emission at 3 m without Distance factor

QP

Ant Deg [deg]	Frequency [MHz]	Detector	Reading [dBuV]	Ant Factor [dB/m]	Loss [dB]	Gain [dB]	Duty Factor [dB]	Result [dBuV/m]	Limit [dBuV/m]	Margin [dB]	Remark
0	13.56000	QP	71.4	19.4	7.0	32.1	-	65.7	-	-	Fundamental

Result = Reading + Ant Factor + Loss (Cable+Attenuator+Filter) - Gain(Amplifier)

Fundamental emission and Spectrum Mask

DATA OF RADIATED EMISSION TEST

UL Japan, Inc. Ise EMC Lab. No.4 Semi Anechoic Chamber
Date : 2016/01/05

Report No. : 11421068H
Temp./Humi. : 25deg. C / 30% RH
Engineer : Ken Fujita

Mode / Remarks : Tx 13.56MHz Without tag TypeB Worst Axis X

Limit1 : FCC15.225_PKQP, 9-90kHz:PK, 110-490kHz:PK, other:QP
Limit2 : FCC15.225_AVQP, 9-90kHz:AV, 110-490kHz:AV, other:QP

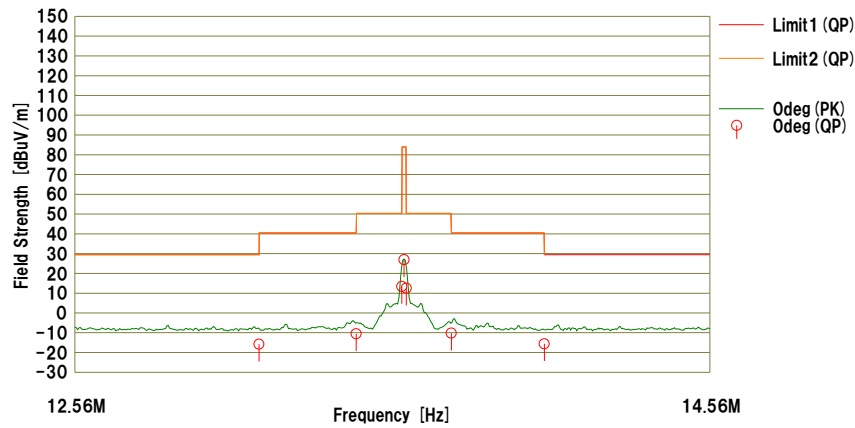

No.	Freq. [MHz]	Reading	AntFac [dB/m]	Loss [dB]	Gain [dB]	Result	Limit		Margin		Antenna [deg]	Table [deg]	Comment
		<QP> [dBuV]				<QP> [dBuV/m]	<QP> [dBuV/m]	<QP> [dB]	<QP> [dB]				
1	13.11000	30.0	19.4	-33.1	32.1	-15.8	29.5	29.5	45.3	45.3	Odeg	84	
2	13.41000	35.3	19.4	-33.1	32.1	-10.5	40.5	40.5	51.0	51.0	Odeg	84	
3	13.55300	59.1	19.4	-33.0	32.1	13.4	50.4	50.4	37.0	37.0	Odeg	84	
4	13.56000	72.6	19.4	-33.0	32.1	26.9	83.9	83.9	57.0	57.0	Odeg	84	
5	13.56700	58.2	19.4	-33.0	32.1	12.5	50.4	50.4	37.9	37.9	Odeg	84	
6	13.71000	35.6	19.4	-33.0	32.1	-10.2	40.5	40.5	50.7	50.7	Odeg	84	
7	14.01000	30.1	19.4	-33.0	32.1	-15.6	29.5	29.5	45.1	45.1	Odeg	84	

CHART:WITH FACTOR Peak hold data.CALCULATION : RESULT = READING + ANT FACTOR + LOSS (CABLE + ATTEN) - GAIN (AMP) + D. FACTOR
Except for the above table : adequate margin data below the limits.

Result of the fundamental emission at 3 m without Distance factor

QP

Ant Deg [deg]	Frequency [MHz]	Detector	Reading [dBuV]	Ant Factor [dB/m]	Loss [dB]	Gain [dB]	Duty Factor [dB]	Result [dBuV/m]	Limit [dBuV/m]	Margin [dB]	Remark
0	13.56000	QP	71.4	19.4	7.0	32.1	-	65.7	-	-	Fundamental

Result = Reading + Ant Factor + Loss (Cable+Attenuator+Filter) - Gain(Amplifier)

Fundamental emission and Spectrum Mask

DATA OF RADIATED EMISSION TEST

UL Japan, Inc. Ise EMC Lab. No.4 Semi Anechoic Chamber
Date : 2016/01/05

Report No. : 11421068H
Temp./Humi. : 25deg. C / 30% RH
Engineer : Ken Fujita

Mode / Remarks : Tx 13.56MHz Without tag TypeF (212kbps) Worst Axis X

Limit1 : FCC15.225_PKQP, 9-90kHz:PK, 110-490kHz:PK, other:QP
Limit2 : FCC15.225_AVQP, 9-90kHz:AV, 110-490kHz:AV, other:QP

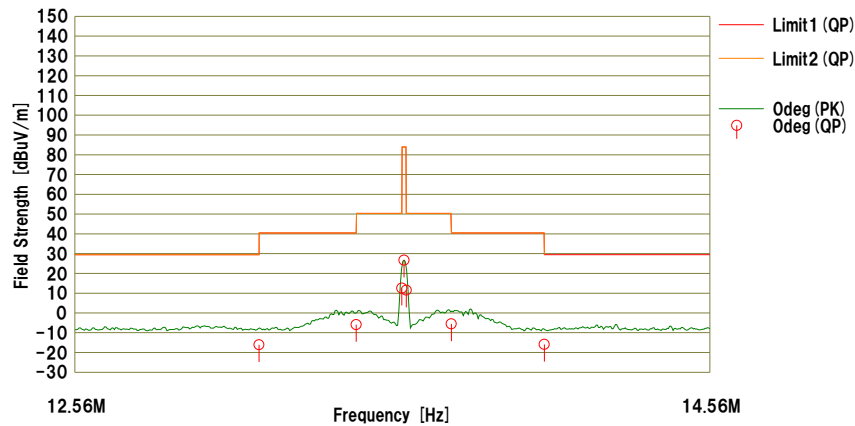

No.	Freq. [MHz]	Reading <QP>		AntFac [dB/m]	Loss [dB]	Gain [dB]	Result <QP>		Limit <QP>		Margin <QP>		Antenna [deg]	Table [deg]	Comment
		[dBuV]	[dB]				[dBuV/m]	[dB]	[dBuV/m]	[dB]	[dB]	[dB]			
1	13.11000	29.7	19.4	-33.1	32.1	-16.1	29.5	29.5	45.6	45.6	Odeg	91			
2	13.41000	39.9	19.4	-33.1	32.1	-5.9	40.5	40.5	46.4	46.4	Odeg	91			
3	13.55300	58.2	19.4	-33.0	32.1	12.5	50.4	50.4	37.9	37.9	Odeg	91			
4	13.56000	72.4	19.4	-33.0	32.1	26.7	83.9	83.9	57.2	57.2	Odeg	91			
5	13.56700	57.2	19.4	-33.0	32.1	11.5	50.4	50.4	38.9	38.9	Odeg	91			
6	13.71000	40.2	19.4	-33.0	32.1	-5.5	40.5	40.5	46.0	46.0	Odeg	91			
7	14.01000	29.8	19.4	-33.0	32.1	-15.9	29.5	29.5	45.4	45.4	Odeg	91			

CHART:WITH FACTOR Peak hold data.CALCULATION : RESULT = READING + ANT FACTOR + LOSS (CABLE + ATTEN) - GAIN (AMP) + D. FACTOR
Except for the above table : adequate margin data below the limits.

Result of the fundamental emission at 3 m without Distance factor

QP

Ant Deg [deg]	Frequency [MHz]	Detector	Reading [dBuV]	Ant Factor [dB/m]	Loss [dB]	Gain [dB]	Duty Factor [dB]	Result [dBuV/m]	Limit [dBuV/m]	Margin [dB]	Remark
0	13.56000	QP	72.4	19.4	7.0	32.1	-	66.7	-	-	Fundamental

Result = Reading + Ant Factor + Loss (Cable+Attenuator+Filter) - Gain(Amplifier)

Fundamental emission and Spectrum Mask

DATA OF RADIATED EMISSION TEST

UL Japan, Inc. Ise EMC Lab. No.4 Semi Anechoic Chamber
Date : 2016/01/05

Report No. : 11421068H
Temp./Humi. : 25deg. C / 30% RH
Engineer : Ken Fujita

Mode / Remarks : Tx 13.56MHz Without tag TypeF (424kbps) Worst Axis X

Limit1 : FCC15.225_PKQP, 9-90kHz:PK, 110-490kHz:PK, other:QP
Limit2 : FCC15.225_AVQP, 9-90kHz:AV, 110-490kHz:AV, other:QP

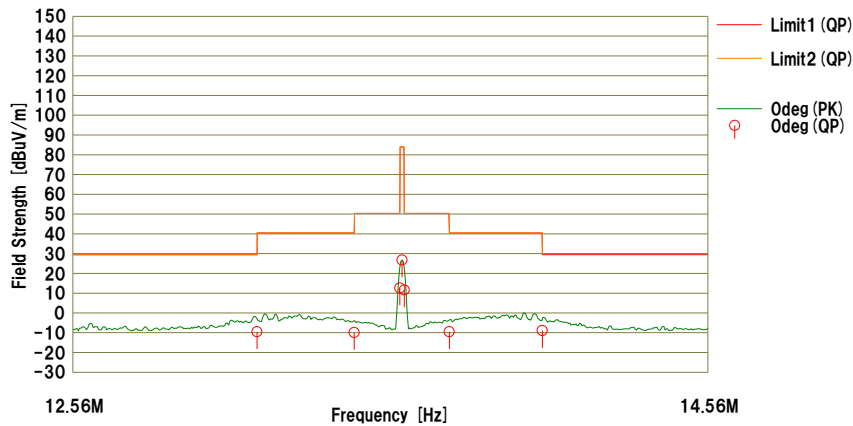

No.	Freq. [MHz]	Reading	AntFac [dB/m]	Loss [dB]	Gain [dB]	Result	Limit		Margin		Antenna [deg]	Table [deg]	Comment
		<QP> [dBuV]				<QP> [dBuV/m]	<QP> [dB]	<QP> [dB]	<QP> [dB]	<QP> [dB]			
1	13.11000	36.3	19.4	-33.1	32.1	-9.5	29.5	29.5	39.0	39.0	Odeg	82	
2	13.41000	35.9	19.4	-33.1	32.1	-9.9	40.5	40.5	50.4	50.4	Odeg	82	
3	13.55300	58.3	19.4	-33.0	32.1	12.6	50.4	50.4	37.8	37.8	Odeg	82	
4	13.56000	72.5	19.4	-33.0	32.1	26.8	83.9	83.9	57.1	57.1	Odeg	82	
5	13.56700	57.3	19.4	-33.0	32.1	11.6	50.4	50.4	38.8	38.8	Odeg	82	
6	13.71000	36.2	19.4	-33.0	32.1	-9.5	40.5	40.5	50.0	50.0	Odeg	82	
7	14.01000	36.8	19.4	-33.0	32.1	-8.9	29.5	29.5	38.4	38.4	Odeg	82	

CHART:WITH FACTOR Peak hold data.CALCULATION : RESULT = READING + ANT FACTOR + LOSS (CABLE + ATTEN) - GAIN (AMP) + D. FACTOR
Except for the above table : adequate margin data below the limits.

Result of the fundamental emission at 3 m without Distance factor

QP											
Ant Deg [deg]	Frequency	Detector	Reading	Ant Factor	Loss	Gain	Duty Factor	Result	Limit	Margin	Remark
	[MHz]		[dBuV]	[dB/m]	[dB]	[dB]	[dB]	[dBuV/m]	[dBuV/m]	[dB]	
0	13.56000	QP	72.5	19.4	7.0	32.1	-	66.8	-	-	Fundamental

Result = Reading + Ant Factor + Loss (Cable+Attenuator+Filter) - Gain(Amplifier)

Spurious emission

DATA OF RADIATED EMISSION TEST

UL Japan, Inc. Ise EMC Lab. No.4 Semi Anechoic Chamber
Date : 2016/01/06

Report No. : 11421068H
Temp./Humi. : 25deg. C / 30% RH
Engineer : Ken Fujita

Mode / Remarks : Tx 13.56MHz With tag TypeA Worst Axis X
Limit1 : FCC15_225_PKQP, 9-90kHz:PK, 110-490kHz:PK, other:QP

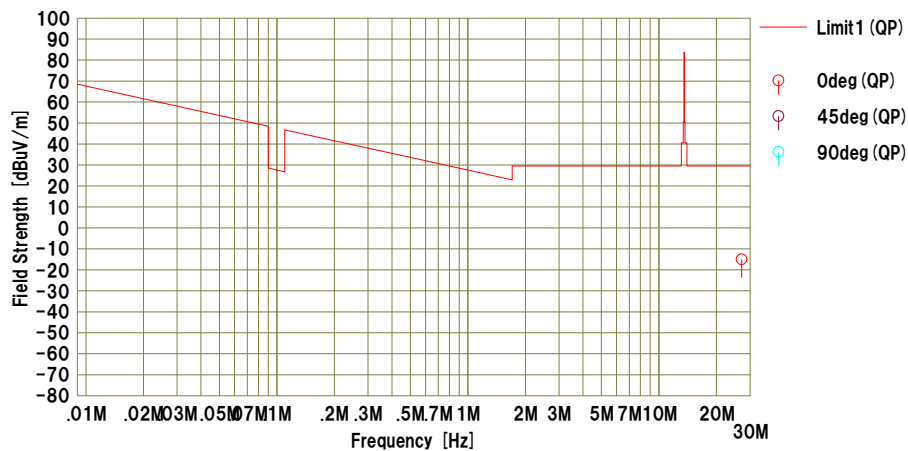

No.	Freq. [MHz]	Reading	Ant.Fac [dB/m]	Loss [dB]	Gain [dB]	Result	Limit	Margin	Antenna	Table	Comment
		<QP> [dBuV]				<QP> [dBuV/m]	<QP> [dB]				
1	27.12000	29.6	20.3	-32.8	32.1	-15.0	29.5	44.5	Odeg	95	

CHART:WITH FACTOR Peak hold data.CALCULATION : RESULT = READING + ANT FACTOR + LOSS (CABLE + ATTEN) - GAIN (AMP) + D. FACTOR
Except for the above table : adequate margin data below the limits.

Spurious emission

DATA OF RADIATED EMISSION TEST

UL Japan, Inc. Ise EMC Lab. No.4 Semi Anechoic Chamber
Date : 2016/01/06

Report No. : 11421068H
Temp./Humi. : 25deg. C / 30% RH
Engineer : Ken Fujita

Mode / Remarks : Tx 13.56MHz With tag TypeB Worst Axis X
Limit1 : FCC15_225_PKQP, 9-90kHz:PK, 110-490kHz:PK, other:QP

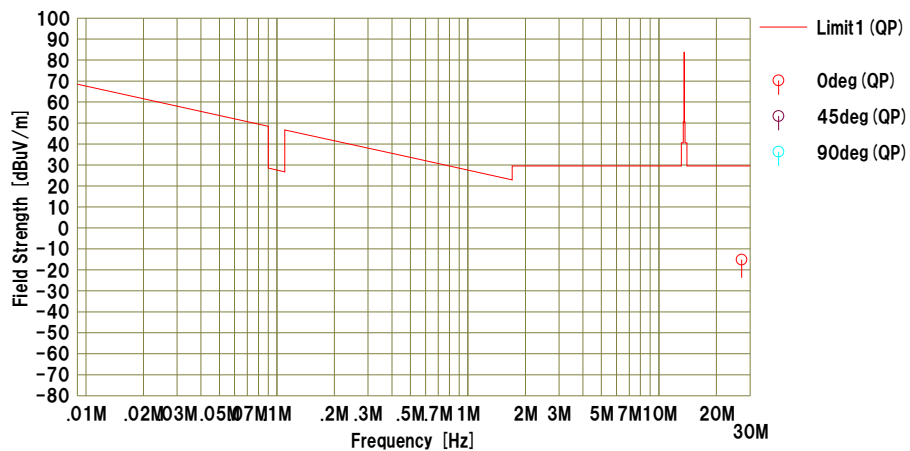

No.	Freq. [MHz]	Reading	Ant.Fac [dB/m]	Loss [dB]	Gain [dB]	Result	Limit	Margin	Antenna	Table [deg]	Comment
		<QP> [dBuV]				<QP> [dBuV/m]	<QP> [dB]				
1	27.12000	29.5	20.3	-32.8	32.1	-15.1	29.5	44.6	Odeg	90	

CHART:WITH FACTOR Peak hold data.CALCULATION : RESULT = READING + ANT FACTOR + LOSS (CABLE + ATTEN) - GAIN (AMP) + D. FACTOR
Except for the above table : adequate margin data below the limits.

Spurious emission

DATA OF RADIATED EMISSION TEST

UL Japan, Inc. Ise EMC Lab. No.4 Semi Anechoic Chamber
Date : 2016/01/06

Report No. : 11421068H
Temp./Humi. : 25deg. C / 30% RH
Engineer : Ken Fujita

Mode / Remarks : Tx 13.56MHz With tag TypeF (212kbps) Worst Axis X
Limit1 : FCC15_225_PKQP, 9-90kHz:PK, 110-490kHz:PK, other:QP

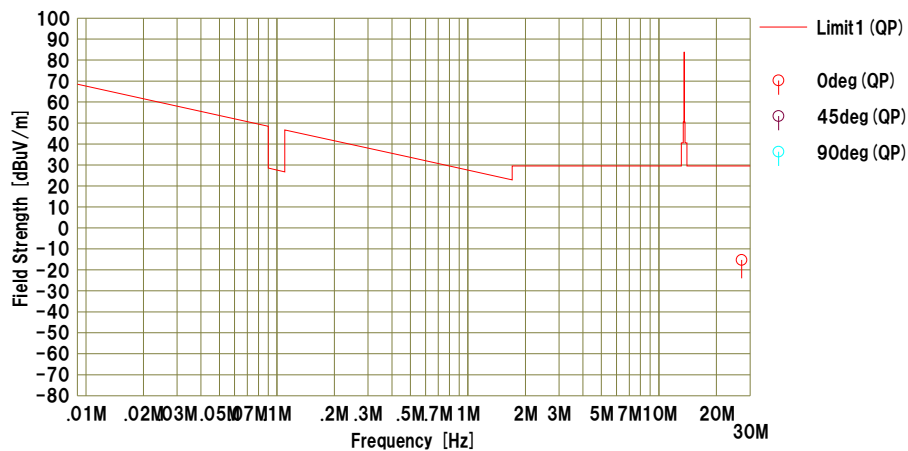

No.	Freq. [MHz]	Reading	Ant.Fac [dB/m]	Loss [dB]	Gain [dB]	Result	Limit	Margin	Antenna	Table [deg]	Comment
		<QP> [dBuV]				<QP> [dBuV/m]	<QP> [dB]				
1	27.12000	29.3	20.3	-32.8	32.1	-15.3	29.5	44.8	Odeg	89	

CHART:WITH FACTOR Peak hold data. CALCULATION : RESULT = READING + ANT FACTOR + LOSS (CABLE + ATTEN) - GAIN (AMP) + D. FACTOR
Except for the above table : adequate margin data below the limits.

Spurious emission

DATA OF RADIATED EMISSION TEST

UL Japan, Inc. Ise EMC Lab. No.4 Semi Anechoic Chamber
Date : 2016/01/06

Report No. : 11421068H
Temp./Humi. : 25deg. C / 30% RH
Engineer : Ken Fujita

Mode / Remarks : Tx 13.56MHz With tag TypeF (424kbps) Worst Axis X
Limit1 : FCC15_225_PKQP, 9-90kHz:PK, 110-490kHz:PK, other:QP

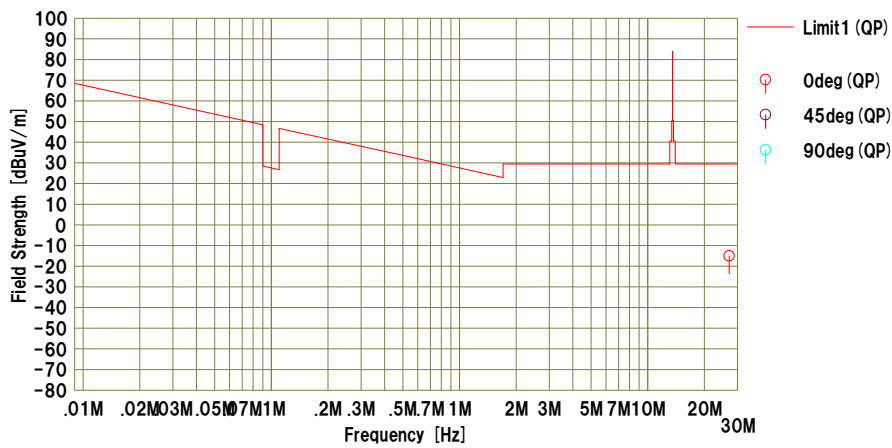

No.	Freq. [MHz]	Reading	Ant.Fac [dB/m]	Loss [dB]	Gain [dB]	Result	Limit	Margin	Antenna	Table	Comment
		<QP> [dBuV]				<QP> [dBuV/m]	<QP> [dB]	<QP> [dB]		<QP> [deg]	
1	27.12000	29.6	20.3	-32.8	32.1	-15.0	29.5	44.5	0deg	92	

CHART:WITH FACTOR Peak hold data.CALCULATION : RESULT = READING + ANT FACTOR + LOSS (CABLE + ATTEN) - GAIN (AMP) + D. FACTOR
Except for the above table : adequate margin data below the limits.

Spurious emission

DATA OF RADIATED EMISSION TEST

UL Japan, Inc. Ise EMC Lab. No.4 Semi Anechoic Chamber
Date : 2016/01/06

Report No. : 11421068H
Temp./Humi. : 25deg. C / 30% RH
Engineer : Ken Fujita

Mode / Remarks : Tx 13.56MHz Without tag TypeA Worst Axis X
Limit1 : FCC15_225_PKQP, 9-90kHz:PK, 110-490kHz:PK, other:QP

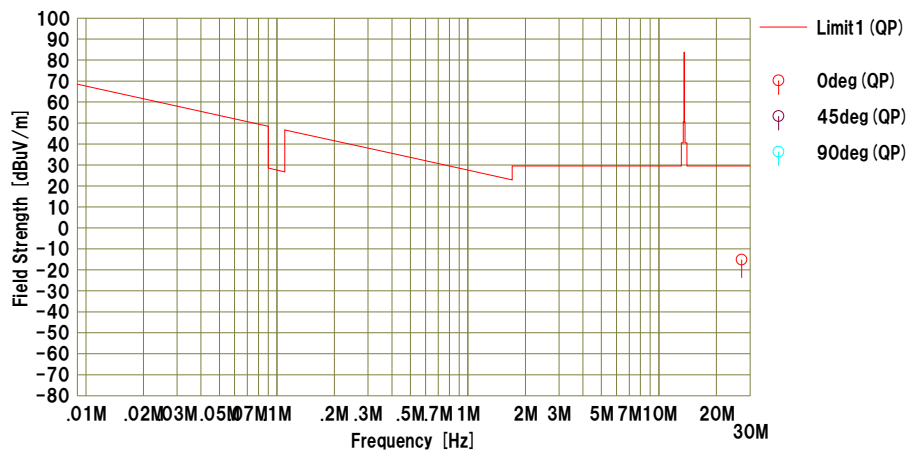

No.	Freq. [MHz]	Reading	Ant.Fac [dB/m]	Loss [dB]	Gain [dB]	Result	Limit	Margin	Antenna	Table [deg]	Comment
		<QP> [dBuV]				<QP> [dBuV/m]	<QP> [dB]				
1	27.12000	29.5	20.3	-32.8	32.1	-15.1	29.5	44.6	Odeg	99	

CHART:WITH FACTOR Peak hold data.CALCULATION : RESULT = READING + ANT FACTOR + LOSS (CABLE + ATTEN) - GAIN (AMP) + D. FACTOR
Except for the above table : adequate margin data below the limits.

Spurious emission

DATA OF RADIATED EMISSION TEST

UL Japan, Inc. Ise EMC Lab. No.4 Semi Anechoic Chamber
Date : 2016/01/06

Report No. : 11421068H
Temp./Humi. : 25deg. C / 30% RH
Engineer : Ken Fujita

Mode / Remarks : Tx 13.56MHz Without tag TypeB Worst Axis X
Limit1 : FCC15_225_PKQP, 9-90kHz:PK, 110-490kHz:PK, other:QP

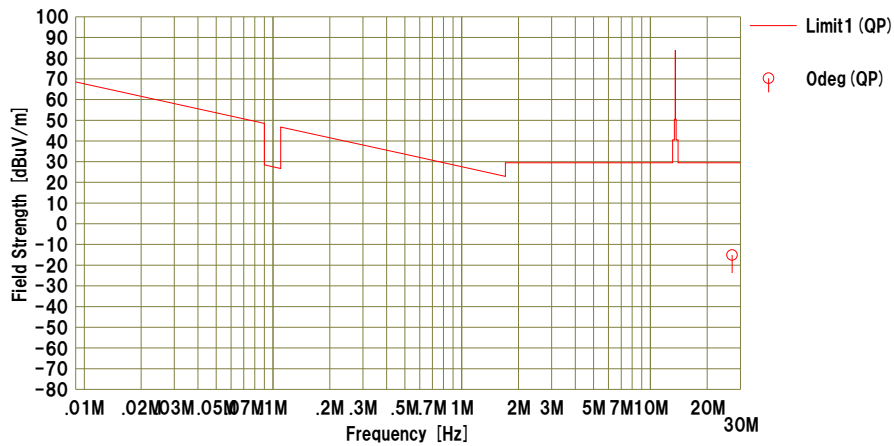

No.	Freq. [MHz]	Reading	AntFac [dB/m]	Loss [dB]	Gain [dB]	Result	Limit	Margin	Antenna	Table	Comment
		<QP> [dBuV]				<QP> [dBuV/m]	<QP> [dB]	<QP> [dB]			
1	27.12000	29.5	20.3	-32.8	32.1	-15.1	29.5	44.6	Odeg	84	

CHART:WITH FACTOR Peak hold data. CALCULATION : RESULT = READING + ANT FACTOR + LOSS (CABLE + ATTEN) - GAIN (AMP) + D. FACTOR
Except for the above table : adequate margin data below the limits.

Spurious emission

DATA OF RADIATED EMISSION TEST

UL Japan, Inc. Ise EMC Lab. No.4 Semi Anechoic Chamber
Date : 2016/01/06

Report No. : 11421068H
Temp./Humi. : 25deg. C / 30% RH
Engineer : Ken Fujita

Mode / Remarks : Tx 13.56MHz Without tag TypeF (212kbps) Worst Axis X

Limit1 : FCC15_225_PKQP, 9-90kHz:PK, 110-490kHz:PK, other:QP

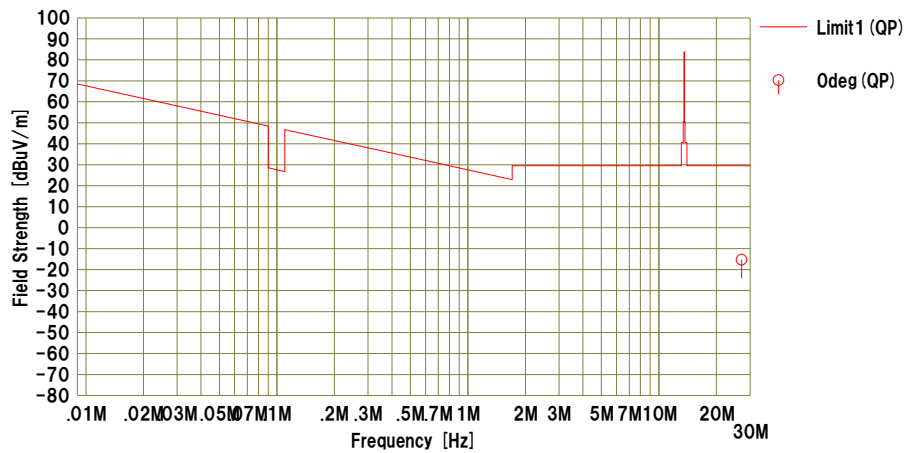

No.	Freq. [MHz]	Reading	Ant.Fac [dB/m]	Loss [dB]	Gain [dB]	Result	Limit	Margin	Antenna	Table	Comment
		<QP> [dBuV]				<QP> [dBuV/m]	<QP> [dB]				
1	27.12000	29.3	20.3	-32.8	32.1	-15.3	29.5	44.8	Odeg	98	

CHART:WITH FACTOR Peak hold data. CALCULATION : RESULT = READING + ANT FACTOR + LOSS (CABLE + ATTEN) - GAIN (AMP) + D. FACTOR
Except for the above table : adequate margin data below the limits.

Spurious emission

DATA OF RADIATED EMISSION TEST

UL Japan, Inc. Ise EMC Lab. No.4 Semi Anechoic Chamber
Date : 2016/01/06

Report No. : 11421068H
Temp./Humi. : 25deg. C / 30% RH
Engineer : Ken Fujita

Mode / Remarks : Tx 13.56MHz Without tag TypeF(424kbps) Worst Axis X
Limit1 : FCC15_225_PKQP, 9-90kHz:PK, 110-490kHz:PK, other:QP

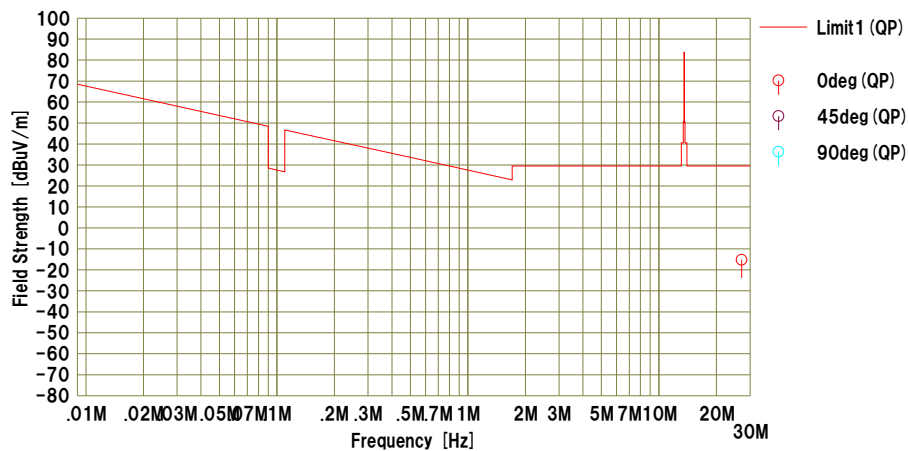

No.	Freq. [MHz]	Reading	Ant.Fac [dB/m]	Loss [dB]	Gain [dB]	Result	Limit	Margin	Antenna	Table	Comment
		<QP> [dBuV]				<QP> [dBuV/m]	<QP> [dB]				
1	27.12000	29.4	20.3	-32.8	32.1	-15.2	29.5	44.7	Odeg	101	

CHART:WITH FACTOR Peak hold data.CALCULATION : RESULT = READING + ANT FACTOR + LOSS (CABLE + ATTEN) - GAIN (AMP) + D. FACTOR
Except for the above table : adequate margin data below the limits.

Spurious emission

DATA OF RADIATED EMISSION TEST

UL Japan, Inc. Ise EMC Lab. No.4 Semi Anechoic Chamber
Date : 2016/01/06

Report No. : 11421068H
Temp./Humi. : 25deg. C / 30% RH
Engineer : Ken Fujita

Mode / Remarks : Tx 13.56MHz withtag TypeA Worst Axis (Hor:X Ver:Y)

Limit1 : FCC15.209 3m, below 1GHz:QP, above 1GHz:PK

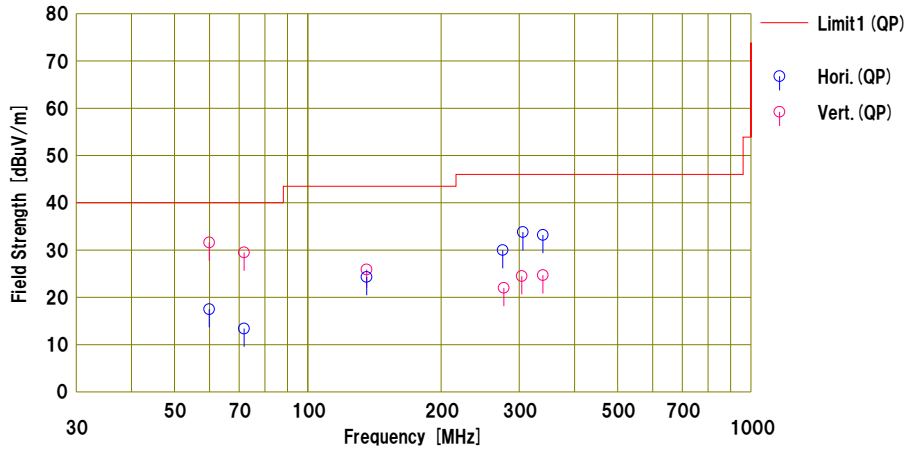

No.	Freq. [MHz]	Reading	Ant.Fac	Loss	Gain	Result	Limit	Margin	Pola.	Height [cm]	Angle [deg.]	Ant. Type	Comment
		<QP> [dBuV]	[dB/m]	[dB]	[dB]	<QP> [dBuV/m]	<QP> [dB]	<QP> [dB]					
1	59.920	48.5	7.5	7.7	32.1	31.6	40.0	8.4	Vert.	100	132	BC	
2	71.820	47.6	6.1	7.9	32.1	29.5	40.0	10.5	Vert.	100	243	BC	
3	305.600	42.1	13.6	9.9	31.8	33.8	46.0	12.2	Hori.	123	223	LA23	
4	339.200	40.7	14.3	10.1	31.9	33.2	46.0	12.8	Hori.	113	341	LA23	
5	275.200	39.3	12.8	9.7	31.8	30.0	46.0	16.0	Hori.	131	244	LA23	
6	135.740	35.3	14.0	8.6	32.0	25.9	43.5	17.6	Vert.	100	223	BC	
7	135.740	33.7	14.0	8.6	32.0	24.3	43.5	19.2	Hori.	400	110	BC	
8	339.200	32.2	14.3	10.1	31.9	24.7	46.0	21.3	Vert.	100	132	LA23	
9	304.000	32.9	13.5	9.9	31.8	24.5	46.0	21.5	Vert.	100	342	LA23	
10	59.920	34.4	7.5	7.7	32.1	17.5	40.0	22.5	Hori.	315	353	BC	
11	276.800	31.2	12.9	9.7	31.8	22.0	46.0	24.0	Vert.	100	158	LA23	
12	71.820	31.5	6.1	7.9	32.1	18.4	40.0	26.6	Hori.	156	311	BC	

CHART:WITH FACTOR Peak hold data.CALCULATION : RESULT = READING + ANT FACTOR + LOSS(CABLE + ATTEN) - GAIN(AMP)
Except for the above table : adequate margin data below the limits.

Spurious emission

DATA OF RADIATED EMISSION TEST

UL Japan, Inc. Ise EMC Lab. No.4 Semi Anechoic Chamber
Date : 2016/01/06

Report No. : 11421068H
Temp./Humi. : 25deg. C / 30% RH
Engineer : Ken Fujita

Mode / Remarks : Tx 13.56MHz withtag TypeB Worst Axis (Hor:X Ver:Y)

Limit1 : FCC15.209 3m, below 1GHz:QP, above 1GHz:PK

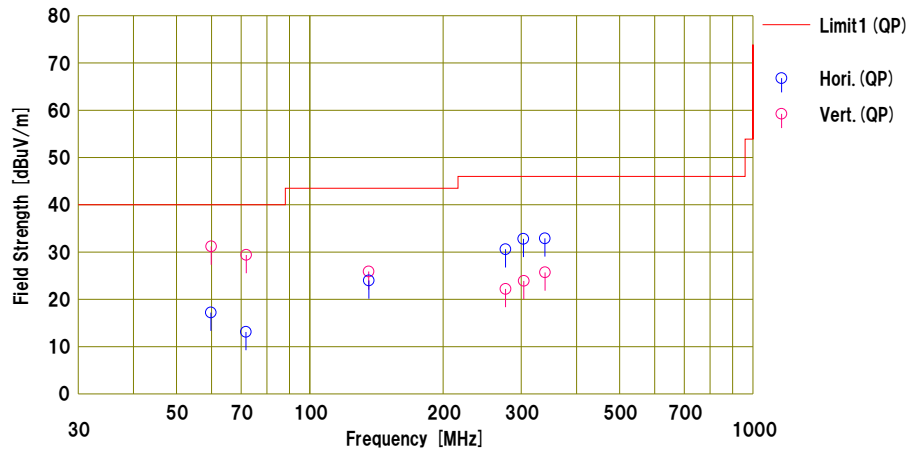

No.	Freq. [MHz]	Reading	Ant.Fac	Loss	Gain	Result	Limit	Margin	Pola.	Height [cm]	Angle [deg]	Ant. Type	Comment
		<QP> [dBuV]	[dB/m]	[dB]	[dB]	<QP> [dBuV/m]	<QP> [dB]	<QP> [dB]					
1	59.922	48.1	7.5	7.7	32.1	31.2	40.0	8.8	Vert.	100	122	BC	
2	71.851	47.5	6.1	7.9	32.1	29.4	40.0	10.6	Vert.	100	247	BC	
3	339.277	40.4	14.3	10.1	31.9	32.9	46.0	13.1	Hori.	223	313	LA23	
4	303.412	41.2	13.5	9.9	31.8	32.8	46.0	13.2	Hori.	256	232	LA23	
5	276.423	39.8	12.9	9.7	31.8	30.6	46.0	15.4	Hori.	245	228	LA23	
6	135.777	35.3	14.0	8.6	32.0	25.9	43.5	17.6	Vert.	100	221	BC	
7	135.843	33.4	14.0	8.6	32.0	24.0	43.5	19.5	Hori.	112	120	BC	
8	339.431	33.2	14.3	10.1	31.9	25.7	46.0	20.3	Vert.	100	129	LA23	
9	304.131	32.3	13.5	9.9	31.8	23.9	46.0	22.1	Vert.	100	322	LA23	
10	59.792	34.1	7.5	7.7	32.1	17.2	40.0	22.8	Hori.	143	331	BC	
11	276.612	31.4	12.9	9.7	31.8	22.2	46.0	23.8	Vert.	100	178	LA23	
12	71.743	31.2	6.1	7.9	32.1	13.1	40.0	26.9	Hori.	112	318	BC	

CHART:WITH FACTOR Peak hold data.CALCULATION : RESULT = READING + ANT FACTOR + LOSS (CABLE + ATTEN) - GAIN (AMP)
Except for the above table : adequate margin data below the limits.

Spurious emission

DATA OF RADIATED EMISSION TEST

UL Japan, Inc. Ise EMC Lab. No.4 Semi Anechoic Chamber
Date : 2016/01/06

Report No. : 11421068H

Temp./Humi. : 25deg. C / 30% RH
Engineer : Ken Fujita

Mode / Remarks : Tx 13.56MHz withtag TypeF (212kbps) Worst Axis (Hor:X Ver:Y)

Limit1 : FCC15.209 3m, below 1GHz:QP, above 1GHz:PK

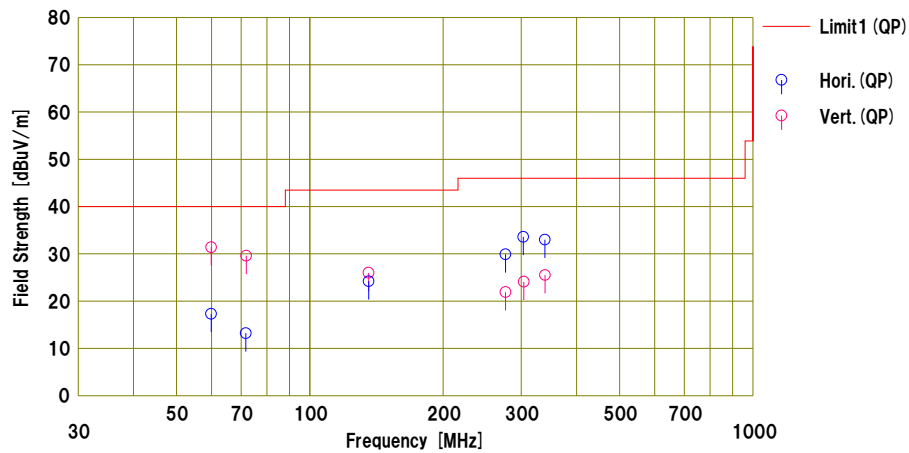

No.	Freq. [MHz]	Reading	Ant.Fac [dB/m]	Loss [dB]	Gain [dB]	Result	Limit	Margin	Pola. [H/V]	Height [cm]	Angle [deg]	Ant. Type	Comment
		[dBuV]				[dBuV/m]	[dB]						
1	59.922	48.3	7.5	7.7	32.1	31.4	40.0	8.6	Vert.	100	133	BC	
2	71.841	47.7	6.1	7.9	32.1	29.6	40.0	10.4	Vert.	100	241	BC	
3	303.213	42.0	13.5	9.9	31.8	33.6	46.0	12.4	Hori.	112	232	LA23	
4	339.212	40.5	14.3	10.1	31.9	33.0	46.0	13.0	Hori.	101	331	LA23	
5	276.412	39.1	12.9	9.7	31.8	29.9	46.0	16.1	Hori.	114	235	LA23	
6	135.751	35.4	14.0	8.6	32.0	26.0	43.5	17.5	Vert.	100	222	BC	
7	135.812	33.6	14.0	8.6	32.0	24.2	43.5	19.3	Hori.	100	111	BC	
8	339.411	33.0	14.3	10.1	31.9	25.5	46.0	20.5	Vert.	100	133	LA23	
9	304.121	32.5	13.5	9.9	31.8	24.1	46.0	21.9	Vert.	100	351	LA23	
10	59.889	34.2	7.5	7.7	32.1	17.3	40.0	22.7	Hori.	100	343	BC	
11	276.562	31.1	12.9	9.7	31.8	21.9	46.0	24.1	Vert.	100	162	LA23	
12	71.723	31.3	6.1	7.9	32.1	13.2	40.0	26.8	Hori.	100	312	BC	

CHART:WITH FACTOR Peak hold data.CALCULATION : RESULT = READING + ANT FACTOR + LOSS (CABLE + ATTEN) - GAIN (AMP)
Except for the above table : adequate margin data below the limits.

Spurious emission

DATA OF RADIATED EMISSION TEST

UL Japan, Inc. Ise EMC Lab. No.4 Semi Anechoic Chamber
Date : 2016/01/06

Report No. : 11421068H

Temp./Humi. : 25deg. C / 30% RH
Engineer : Ken Fujita

Mode / Remarks : Tx 13.56MHz withtag TypeF (424kbps) Worst Axis (Hor:X Ver:Y)

Limit1 : FCC15.209 3m, below 1GHz:QP, above 1GHz:PK

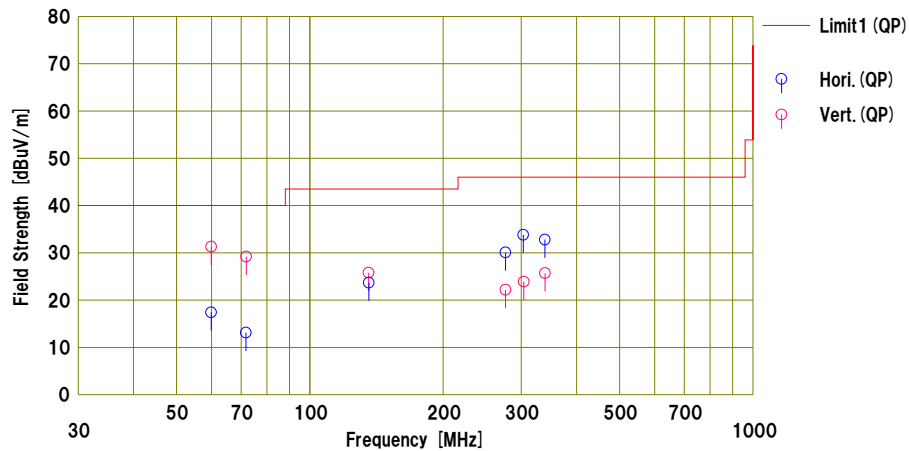

No.	Freq. [MHz]	Reading	Ant.Fac [dB/m]	Loss [dB]	Gain [dB]	Result	Limit	Margin	Pola. [H/V]	Height [cm]	Angle [deg]	Ant. Type	Comment
		<QP> [dBuV]				<QP> [dBuV/m]	<QP> [dB]						
1	59.923	48.2	7.5	7.7	32.1	31.3	40.0	8.7	Vert.	100	129	BC	
2	71.855	47.3	6.1	7.9	32.1	29.2	40.0	10.8	Vert.	100	244	BC	
3	303.214	42.2	13.5	9.9	31.8	33.8	46.0	12.2	Hori.	165	233	LA23	
4	339.245	40.3	14.3	10.1	31.9	32.8	46.0	13.2	Hori.	156	331	LA23	
5	276.442	39.3	12.9	9.7	31.8	30.1	46.0	15.9	Hori.	144	233	LA23	
6	135.761	35.2	14.0	8.6	32.0	25.8	43.5	17.7	Vert.	100	217	BC	
7	135.844	33.1	14.0	8.6	32.0	23.7	43.5	19.8	Hori.	335	117	BC	
8	339.425	33.2	14.3	10.1	31.9	25.7	46.0	20.3	Vert.	100	131	LA23	
9	304.132	32.3	13.5	9.9	31.8	23.9	46.0	22.1	Vert.	100	349	LA23	
10	59.878	34.3	7.5	7.7	32.1	17.4	40.0	22.6	Hori.	376	344	BC	
11	276.577	31.4	12.9	9.7	31.8	22.2	46.0	23.8	Vert.	100	187	LA23	
12	71.732	31.2	6.1	7.9	32.1	13.1	40.0	26.9	Hori.	354	321	BC	

CHART:WITH FACTOR Peak hold data.CALCULATION : RESULT = READING + ANT FACTOR + LOSS (CABLE + ATTEN) - GAIN (AMP)
Except for the above table : adequate margin data below the limits.

Spurious emission

DATA OF RADIATED EMISSION TEST

UL Japan, Inc. Ise EMC Lab. No.4 Semi Anechoic Chamber
Date : 2016/01/06

Report No. : 11421068H
Temp./Humi. : 25deg. C / 30% RH
Engineer : Ken Fujita

Mode / Remarks : Tx 13.56MHz without tag TypeA Worst Axis (Hor:X Ver:Y)

Limit1 : FCC15.209 3m, below 1GHz:QP, above 1GHz:PK

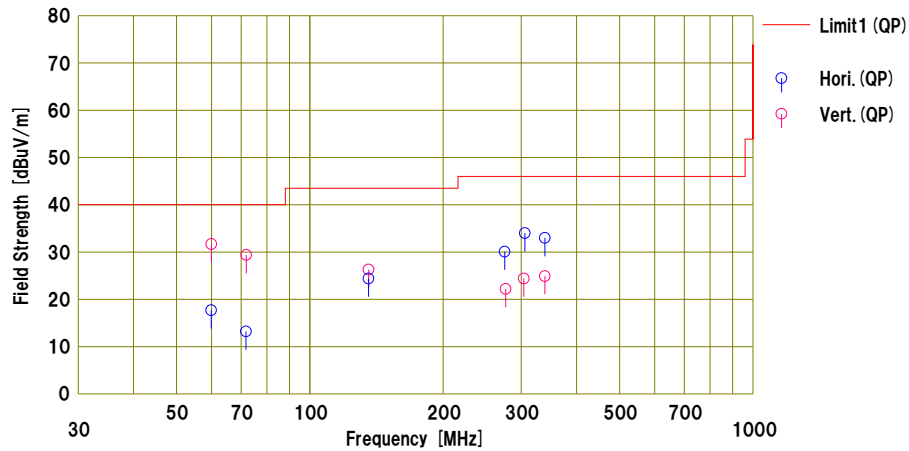

No.	Freq. [MHz]	Reading	Ant.Fac	Loss	Gain	Result	Limit	Margin	Pola.	Height [cm]	Angle [deg.]	Ant. Type	Comment
		<QP> [dBuV]	[dB/m]	[dB]	[dB]	<QP> [dBuV/m]	<QP> [dB]	<QP> [dB]					
1	59.932	48.6	7.5	7.7	32.1	31.7	40.0	8.3	Vert.	100	133	BC	
2	71.842	47.5	6.1	7.9	32.1	29.4	40.0	10.6	Vert.	100	247	BC	
3	305.611	42.3	13.6	9.9	31.8	34.0	46.0	12.0	Hori.	113	243	LA23	
4	339.231	40.5	14.3	10.1	31.9	33.0	46.0	13.0	Hori.	117	339	LA23	
5	275.279	39.4	12.8	9.7	31.8	30.1	46.0	15.9	Hori.	121	254	LA23	
6	135.741	35.7	14.0	8.6	32.0	26.3	43.5	17.2	Vert.	100	221	BC	
7	135.681	33.8	14.0	8.6	32.0	24.4	43.5	19.1	Hori.	100	111	BC	
8	339.189	32.4	14.3	10.1	31.9	24.9	46.0	21.1	Vert.	100	133	LA23	
9	304.117	32.8	13.5	9.9	31.8	24.4	46.0	21.6	Vert.	100	11	LA23	
10	59.899	34.6	7.5	7.7	32.1	17.7	40.0	22.3	Hori.	100	3	BC	
11	276.727	31.4	12.9	9.7	31.8	22.2	46.0	23.8	Vert.	100	14	LA23	
12	71.781	31.3	6.1	7.9	32.1	13.2	40.0	26.8	Hori.	100	12	BC	

CHART:WITH FACTOR Peak hold data.CALCULATION : RESULT = READING + ANT FACTOR + LOSS (CABLE + ATTEN) - GAIN (AMP)
Except for the above table : adequate margin data below the limits.

Spurious emission

DATA OF RADIATED EMISSION TEST

UL Japan, Inc. Ise EMC Lab. No.4 Semi Anechoic Chamber
Date : 2016/01/06

Report No. : 11421068H
Temp./Humi. : 25deg. C / 30% RH
Engineer : Ken Fujita

Mode / Remarks : Tx 13.56MHz without tag TypeB Worst Axis (Hor:X Ver:Y)

Limit1 : FCC15.209 3m, below 1GHz:QP, above 1GHz:PK

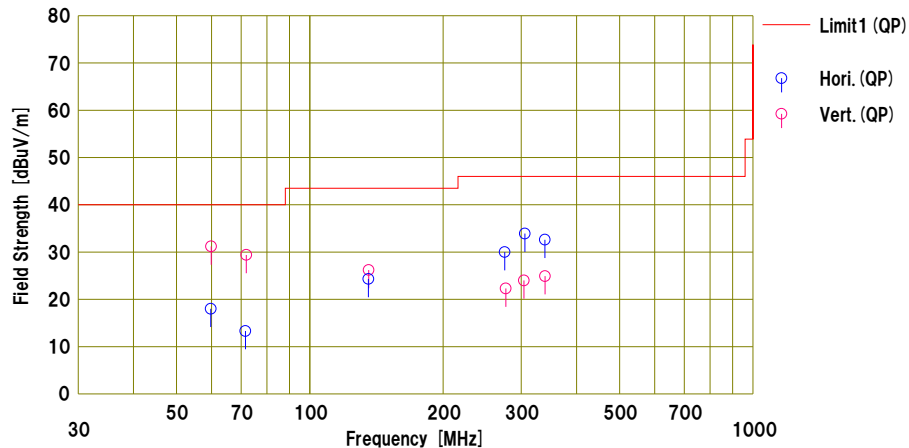

No.	Freq. [MHz]	Reading	Ant.Fac	Loss	Gain	Result	Limit	Margin	Pola.	Height [cm]	Angle [deg]	Ant. Type	Comment
		<QP> [dBuV]	[dB/m]	[dB]	[dB]	<QP> [dBuV/m]	<QP> [dB]	<QP> [dB]					
1	59.878	48.1	7.5	7.7	32.1	31.2	40.0	8.8	Vert.	100	132	BC	
2	71.868	47.5	6.1	7.9	32.1	29.4	40.0	10.6	Vert.	100	240	BC	
3	305.599	42.2	13.6	9.9	31.8	33.9	46.0	12.1	Hori.	198	228	LA23	
4	339.317	40.1	14.3	10.1	31.9	32.6	46.0	13.4	Hori.	178	318	LA23	
5	275.292	39.3	12.8	9.7	31.8	30.0	46.0	16.0	Hori.	177	246	LA23	
6	135.832	35.6	14.0	8.6	32.0	26.2	43.5	17.3	Vert.	100	220	BC	
7	135.579	33.7	14.0	8.6	32.0	24.3	43.5	19.2	Hori.	100	122	BC	
8	339.341	32.4	14.3	10.1	31.9	24.9	46.0	21.1	Vert.	100	132	LA23	
9	59.778	34.9	7.5	7.7	32.1	18.0	40.0	22.0	Hori.	100	10	BC	
10	304.228	32.4	13.5	9.9	31.8	24.0	46.0	22.0	Vert.	100	11	LA23	
11	276.883	31.5	12.9	9.7	31.8	22.3	46.0	23.7	Vert.	100	15	LA23	
12	71.592	31.4	6.1	7.9	32.1	13.3	40.0	26.7	Hori.	100	17	BC	

CHART:WITH FACTOR Peak hold data.CALCULATION : RESULT = READING + ANT FACTOR + LOSS(CABLE + ATTEN) - GAIN(AMP)
Except for the above table : adequate margin data below the limits.

Spurious emission

DATA OF RADIATED EMISSION TEST

UL Japan, Inc. Ise EMC Lab. No.4 Semi Anechoic Chamber
Date : 2016/01/06

Report No. : 11421068H

Temp./Humi. : 25deg. C / 30% RH
Engineer : Ken Fujita

Mode / Remarks : Tx 13.56MHz without tag TypeF (212kbps) Worst Axis (Hor:X Ver:Y)

Limit1 : FCC15.209 3m. below 1GHz:QP, above 1GHz:PK

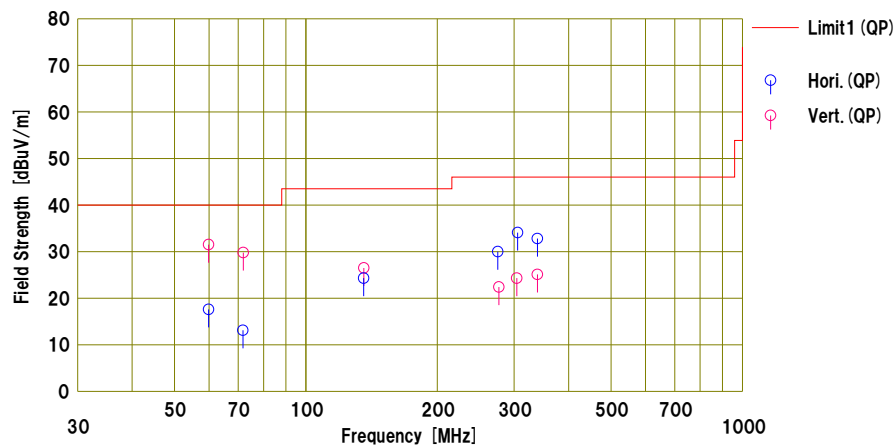

No.	Freq. [MHz]	Reading	Ant.Fac	Loss	Gain	Result	Limit	Margin	Pola.	Height [cm]	Angle [deg]	Ant. Type	Comment
		<QP> [dBuV]	[dB/m]	[dB]	[dB]	<QP> [dBuV/m]	<QP> [dBuV/m]	<QP> [dB]					
1	59.892	48.4	7.5	7.7	32.1	31.5	40.0	8.5	Vert.	100	128	BC	
2	71.898	47.8	6.2	7.9	32.1	29.8	40.0	10.2	Vert.	100	233	BC	
3	305.632	42.4	13.6	9.9	31.8	34.1	46.0	11.9	Hori.	178	242	LA23	
4	339.228	40.3	14.3	10.1	31.9	32.8	46.0	13.2	Hori.	182	336	LA23	
5	275.281	39.3	12.8	9.7	31.8	30.0	46.0	16.0	Hori.	167	252	LA23	
6	135.819	35.9	14.0	8.6	32.0	26.5	43.5	17.0	Vert.	100	218	BC	
7	135.672	33.7	14.0	8.6	32.0	24.3	43.5	19.2	Hori.	100	111	BC	
8	339.312	32.6	14.3	10.1	31.9	25.1	46.0	20.9	Vert.	100	128	LA23	
9	304.201	32.7	13.5	9.9	31.8	24.3	46.0	21.7	Vert.	100	8	LA23	
10	59.881	34.5	7.5	7.7	32.1	17.6	40.0	22.4	Hori.	100	3	BC	
11	276.802	31.6	12.9	9.7	31.8	22.4	46.0	23.6	Vert.	100	11	LA23	
12	71.756	31.2	6.1	7.9	32.1	13.1	40.0	26.9	Hori.	100	12	BC	

CHART:WITH FACTOR Peak hold data. CALCULATION : RESULT = READING + ANT FACTOR + LOSS (GABLE + ATTEN) - GAIN (AMP)
Except for the above table : adequate margin data below the limits.

Spurious emission

DATA OF RADIATED EMISSION TEST

UL Japan, Inc. Ise EMC Lab. No.4 Semi Anechoic Chamber
Date : 2016/01/06

Report No. : 11421068H
Temp./Humi. : 25deg. C / 30% RH
Engineer : Ken Fujita
Worst Axis (Hor:X Ver:Y)

Mode / Remarks : Tx 13.56MHz without tag TypeF (424kbps)

Limit1 : FCC15.209 3m, below 1GHz:QP, above 1GHz:PK

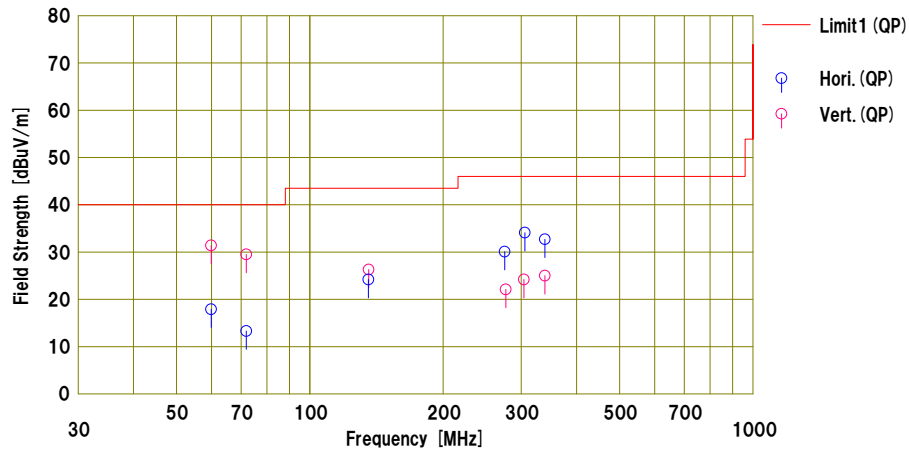

No.	Freq. [MHz]	Reading	Ant.Fac	Loss	Gain	Result	Limit	Margin	Pola.	Height [cm]	Angle [deg.]	Ant. Type	Comment
		<QP> [dBuV]	[dB/m]	[dB]	[dB]	<QP> [dBuV/m]	<QP> [dB]	<QP> [dB]					
1	59.893	48.3	7.5	7.7	32.1	31.4	40.0	8.6	Vert.	100	126	BC	
2	71.871	47.6	6.1	7.9	32.1	29.5	40.0	10.5	Vert.	100	234	BC	
3	305.633	42.4	13.6	9.9	31.8	34.1	46.0	11.9	Hori.	178	239	LA23	
4	339.224	40.2	14.3	10.1	31.9	32.7	46.0	13.3	Hori.	182	328	LA23	
5	275.284	39.4	12.8	9.7	31.8	30.1	46.0	15.9	Hori.	178	247	LA23	
6	135.821	35.7	14.0	8.6	32.0	26.3	43.5	17.2	Vert.	100	221	BC	
7	135.598	33.6	14.0	8.6	32.0	24.2	43.5	19.3	Hori.	100	123	BC	
8	339.331	32.5	14.3	10.1	31.9	25.0	46.0	21.0	Vert.	100	128	LA23	
9	304.214	32.6	13.5	9.9	31.8	24.2	46.0	21.8	Vert.	100	9	LA23	
10	59.876	34.8	7.5	7.7	32.1	17.9	40.0	22.1	Hori.	100	7	BC	
11	276.881	31.3	12.9	9.7	31.8	22.1	46.0	23.9	Vert.	100	12	LA23	
12	71.891	31.3	6.2	7.9	32.1	13.3	40.0	26.7	Hori.	100	16	BC	

CHART:WITH FACTOR Peak hold data.CALCULATION : RESULT = READING + ANT FACTOR + LOSS(CABLE + ATTEN) - GAIN(AMP)
Except for the above table : adequate margin data below the limits.

20dB Bandwidth and 99% Occupied Bandwidth

Test place	Ise EMC Lab. No.11 measurement room
Report No.	11421068H
Date	01/10/2017
Temperature/ Humidity	24 deg. C / 31 % RH
Engineer	Ken Fujita
Mode	Tx Mod on TypeA

FREQ [MHz]	Mode	20dB Bandwidth [kHz]	99% Occupied Bandwidth [kHz]
13.56	Without Tag	3.06	86.75
	With Tag	3.32	20.19

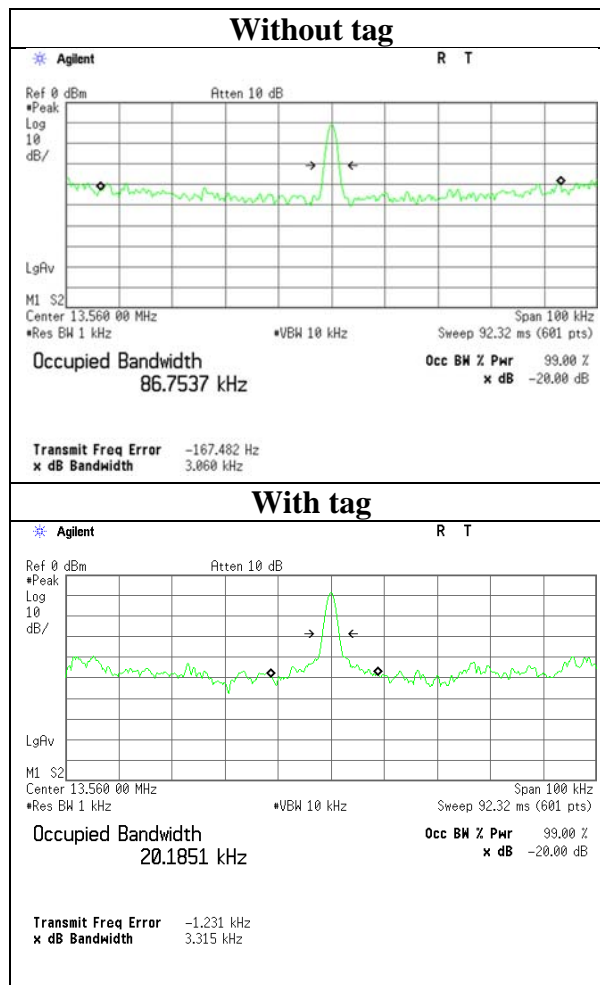

20dB Bandwidth and 99% Occupied Bandwidth

Test place	Ise EMC Lab. No.11 measurement room
Report No.	11421068H
Date	01/10/2017
Temperature/ Humidity	24 deg. C / 31 % RH
Engineer	Ken Fujita
Mode	Tx Mod on TypeB

FREQ [MHz]	Mode	20dB Bandwidth [kHz]	99% Occupied Bandwidth [kHz]
13.56	Without Tag	3.10	56.91
	With Tag	5.70	15.60

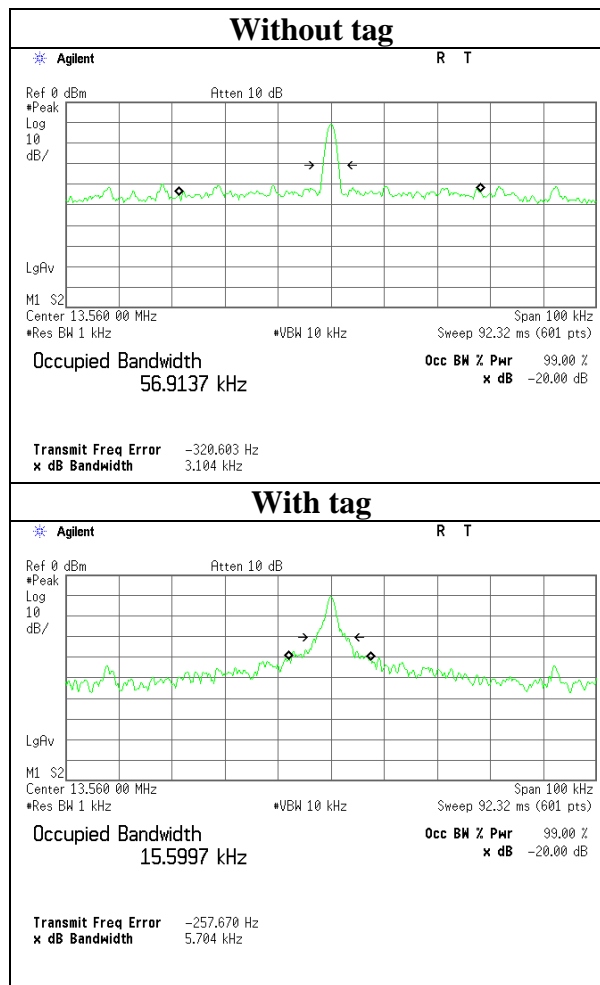

20dB Bandwidth and 99% Occupied Bandwidth

Test place	Ise EMC Lab. No.11 measurement room
Report No.	11421068H
Date	01/10/2017
Temperature/ Humidity	24 deg. C / 31 % RH
Engineer	Ken Fujita
Mode	Tx Mod on TypeF(212kbps)

FREQ [MHz]	Mode	20dB Bandwidth [kHz]	99% Occupied Bandwidth [kHz]
13.56	Without Tag	3.04	2.57
	With Tag	3.34	3.04

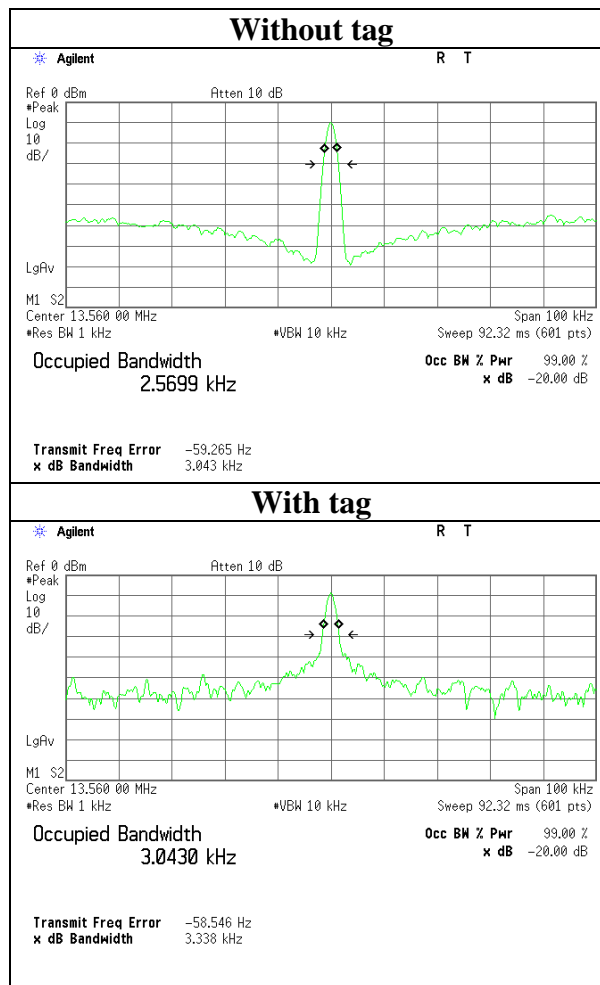

20dB Bandwidth and 99% Occupied Bandwidth

Test place	Ise EMC Lab. No.11 measurement room
Report No.	11421068H
Date	01/10/2017
Temperature/ Humidity	24 deg. C / 31 % RH
Engineer	Ken Fujita
Mode	Tx Mod on TypeF(424kbps)

FREQ [MHz]	Mode	20dB Bandwidth [kHz]	99% Occupied Bandwidth [kHz]
13.56	Without Tag	3.04	2.55
	With Tag	3.23	2.80

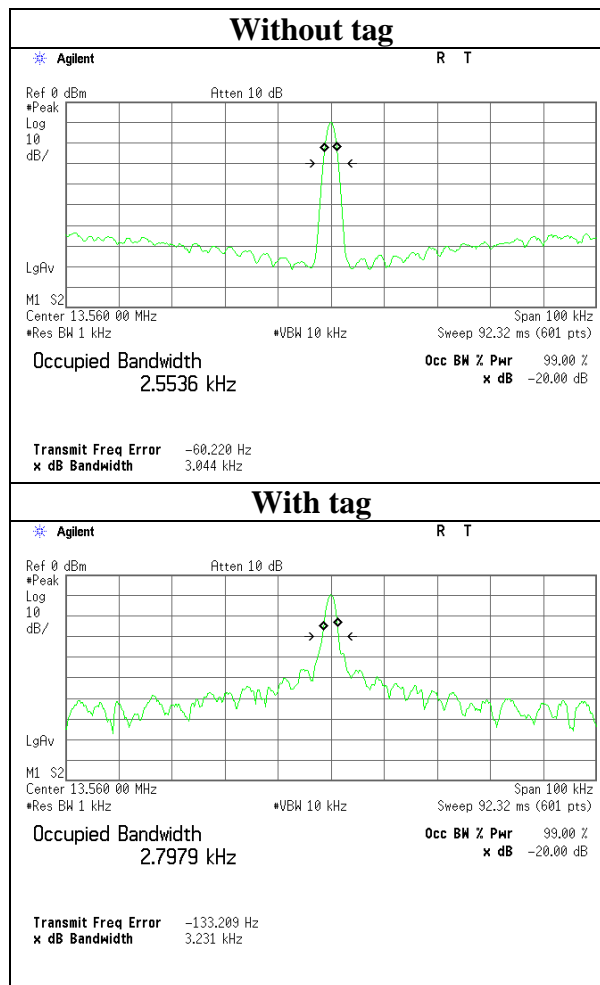

UL Japan, Inc.

Ise EMC Lab.

4383-326 Asama-cho, Ise-shi, Mie-ken 516-0021 JAPAN

Telephone : +81 596 24 8999

Facsimile : +81 596 24 8124

Frequency Tolerance

Test place : Ise EMC Lab. No.11 measurement room
Report No. : 11421068H
Date : 02/22/2017
Temperature/ Humidity : 22 deg. C / 38 % RH
Engineer : Ken Fujita
Mode : Tx Mod off Without Tag

Test condition		Tested timing	Measured frequency [MHz]	Frequency error [MHz]	Result		Limit [+/- %]
Temp. [deg. C]	Voltage [V]				[%]	[ppm]	
50	5	Power on	13.559821	-0.000179	-0.00132	-13.2	0.01
		+ 2 min.	13.559824	-0.000176	-0.00130	-13.0	0.01
		+ 5 min.	13.559822	-0.000178	-0.00131	-13.1	0.01
		+ 10 min.	13.559820	-0.000180	-0.00133	-13.3	0.01
40	5	Power on	13.559911	-0.000089	-0.00066	-6.6	0.01
		+ 2 min.	13.559848	-0.000152	-0.00112	-11.2	0.01
		+ 5 min.	13.559843	-0.000157	-0.00116	-11.6	0.01
		+ 10 min.	13.559844	-0.000156	-0.00115	-11.5	0.01
30	5	Power on	13.559933	-0.000067	-0.00049	-4.9	0.01
		+ 2 min.	13.559879	-0.000121	-0.00089	-8.9	0.01
		+ 5 min.	13.559876	-0.000124	-0.00091	-9.1	0.01
		+ 10 min.	13.559868	-0.000132	-0.00097	-9.7	0.01
20	5	Power on	13.559890	-0.000110	-0.00081	-8.1	0.01
		+ 2 min.	13.559928	-0.000072	-0.00053	-5.3	0.01
		+ 5 min.	13.559912	-0.000088	-0.00065	-6.5	0.01
		+ 10 min.	13.559916	-0.000084	-0.00062	-6.2	0.01
20	4.25	Power on	13.559931	-0.000069	-0.00051	-5.1	0.01
		+ 2 min.	13.559921	-0.000079	-0.00058	-5.8	0.01
		+ 5 min.	13.559915	-0.000085	-0.00063	-6.3	0.01
		+ 10 min.	13.559899	-0.000101	-0.00074	-7.4	0.01
20	5.75	Power on	13.559919	-0.000081	-0.00060	-6.0	0.01
		+ 2 min.	13.559912	-0.000088	-0.00065	-6.5	0.01
		+ 5 min.	13.559902	-0.000098	-0.00072	-7.2	0.01
		+ 10 min.	13.559889	-0.000111	-0.00082	-8.2	0.01
10	5	Power on	13.560053	0.000053	0.00039	3.9	0.01
		+ 2 min.	13.559982	-0.000018	-0.00013	-1.3	0.01
		+ 5 min.	13.559961	-0.000039	-0.00029	-2.9	0.01
		+ 10 min.	13.559949	-0.000051	-0.00038	-3.8	0.01
0	5	Power on	13.560088	0.000088	0.00065	6.5	0.01
		+ 2 min.	13.560037	0.000037	0.00027	2.7	0.01
		+ 5 min.	13.560021	0.000021	0.00015	1.5	0.01
		+ 10 min.	13.560011	0.000011	0.00008	0.8	0.01
-10	5	Power on	13.560095	0.000095	0.00070	7.0	0.01
		+ 2 min.	13.560061	0.000061	0.00045	4.5	0.01
		+ 5 min.	13.560055	0.000055	0.00041	4.1	0.01
		+ 10 min.	13.560051	0.000051	0.00038	3.8	0.01
-20	5	Power on	13.560075	0.000075	0.00055	5.5	0.01
		+ 2 min.	13.560091	0.000091	0.00067	6.7	0.01
		+ 5 min.	13.560085	0.000085	0.00063	6.3	0.01
		+ 10 min.	13.560083	0.000083	0.00061	6.1	0.01
-30 *	5	Power on	13.560031	0.000031	0.00023	2.3	0.01
		+ 2 min.	13.560089	0.000089	0.00066	6.6	0.01
		+ 5 min.	13.560095	0.000095	0.00070	7.0	0.01
		+ 10 min.	13.560093	0.000093	0.00069	6.9	0.01

Calculation formula: Frequency error = Measured frequency - Tested frequency
Result [%] = Frequency error / Tested frequency * 100

*The test was begun from 50 deg.C and the temperature was lowered each 10 deg.C.

* for IC application (RSS-Gen 6.11 requirement)

APPENDIX 2: Test instruments

EMI test equipment

Control No.	Instrument	Manufacturer	Model No	Serial No	Test Item	Calibration Date * Interval(month)
MAEC-02	Semi Anechoic Chamber(NSA)	TDK	Semi Anechoic Chamber 3m	DA-06902	CE	2016/08/02 * 12
MOS-22	Thermo-Hygrometer	Custom	CTH-201	0003	CE	2016/12/13 * 12
MJM-14	Measure	KOMELON	KMC-36	-	CE	-
MSA-04	Spectrum Analyzer	Agilent	E4448A	US44300523	CE	2016/11/10 * 12
MLS-23	LISN(AMN)	Schwarzbeck	NSLK8127	8127-729	CE	2016/07/07 * 12
MCC-13	Coaxial Cable	Fujikura	3D-2W(12m)/5D-2W(5m)/5D-2W(0.8m)/5D-2W(1m)	-	CE	2016/02/08 * 12
MAT-65	Attenuator(13dB)	JFW Industries, Inc.	50FP-013H2 N	-	CE	2016/12/21 * 12
MMM-01	Digital Tester	Fluke	FLUKE 26-3	78030611	CE	2016/08/23 * 12
MAEC-04	Semi Anechoic Chamber(NSA)	TDK	Semi Anechoic Chamber 3m	DA-10005	RE	2016/10/19 * 12
MOS-15	Thermo-Hygrometer	Custom	CTH-180	1501	RE	2016/01/21 * 12 *1)
MJM-26	Measure	KOMELON	KMC-36	-	RE	-
COTS-MEMI	EMI measurement program	TSJ	TEPTO-DV	-	RE	-
MTR-03	Test Receiver	Rohde & Schwarz	ESCI	100300	RE	2016/10/21 * 12
MLPA-01	Loop Antenna	Rohde & Schwarz	HFH2-Z2	100017	RE	2016/10/14 * 12
MCC-113	Coaxial cable	Fujikura/Suhner/TSJ	5D-2W(10m)/SFM141(5m)/421-010(1m)/suciform141-PE(1m)/RFM-E121(Switcher)	-/04178	RE	2016/07/20 * 12
MCC-143	Coaxial Cable	UL Japan	-	-	RE	2016/06/20 * 12
MPA-14	Pre Amplifier	SONOMA INSTRUMENT	310	260833	RE	2016/03/18 * 12
MAT-07	Attenuator(6dB)	Weinschel Corp	2	BK7970	RE	2016/11/28 * 12
MMM-10	DIGITAL HiTESTER	Hioki	3805	051201148	RE	2016/01/18 * 12 *1)
MTR-10	EMI Test Receiver	Rohde & Schwarz	ESR26	101408	RE	2016/01/29 * 12 *1)
MBA-05	Biconical Antenna	Schwarzbeck	BBA9106	1302	RE	2016/11/23 * 12
MLA-23	Logperiodic Antenna(200-1000MHz)	Schwarzbeck	VUSLP9111B	911B-192	RE	2016/01/30 * 12 *1)
MCC-50	Coaxial Cable	UL Japan	-	-	RE	2016/06/20 * 12
MAT-97	Attenuator	KEYSIGHT	8491A	MY52462282	RE	2016/10/31 * 12
MCH-06	Temperature and Humidity Chamber	Tabai Espec	PL-1KT	14007630	FT	2016/04/18 * 12
MFC-01	Microwave Counter	Advantest	R5373	120100309	FT	2016/06/01 * 12
MAT-17	Attenuator(20dB)_DC-1GHz_N	Weinschel Corp	MODEL 1	BG0143	FT	2016/12/24 * 12
MOS-19	Thermo-Hygrometer	Custom	CTH-201	0001	FT	2016/12/13 * 12
MMM-17	DIGITAL HiTESTER	Hioki	3805	070900530	FT	2017/01/19 * 12
MSA-14	Spectrum Analyzer	Agilent	E4440A	MY48250080	FT	2016/10/14 * 12

*1) This test equipment was used for the tests before the expiration date of the calibration.

The expiration date of the calibration is the end of the expired month.

All equipment is calibrated with valid calibrations. Each measurement data is traceable to the national or international standards.

As for some calibrations performed after the tested dates, those test equipment have been controlled by means of an unbroken chains of calibrations.

Test Item: CE: Conducted Emission
RE: Radiated Emission
FT: Frequency Tolerance

UL Japan, Inc.

Ise EMC Lab.

4383-326 Asama-cho, Ise-shi, Mie-ken 516-0021 JAPAN

Telephone : +81 596 24 8999

Facsimile : +81 596 24 8124