

# EMISSION TEST REPORT

Test Report No. : **21KE0071-YW-2**

**Applicant:** OMRON CORPORATION

**Type of Equipment:** Keyless Entry System (Receiver)

**Model No.:** G8D-344H-B

**FCC ID** OUCG8D-344H-B

**Test standard:** FCC Part 15 Subpart B Section 15.109(a)

**Test Result:** Complies

This report may not be reproduced in full, partial reproduction may only be made with the written consent of the laboratory.

The results in this report apply only to the sample tested.

Date of test: July 2, 2001

Tested by:   
Makoto Kosaka

Approved by:  Issued date: July 5, 2001  
Kazutoyo Nakanishi  
Section Manager of EMC section

Testing Laboratory

**A-pex International Co., Ltd.**

108 Yokowa-cho, Ise-shi Mie-ken 516-1106 JAPAN

Telephone: +81 596 39 1485

Facsimile: +81 596 39 0232

<b>Table of Contents</b>	<b>Page</b>
<b>1 GENERAL INFORMATION</b>	<b>3</b>
1.1 Product Description	4
1.2 Test Specification	4
1.3 Methods & Procedures	4
1.4 Exclusion from standards	4
1.5 Test Location	4
<b>2 SYSTEM TEST CONFIGURATION</b>	<b>5</b>
2.1 Operation Environment	5
2.2 Justification	5
2.3 EUT Exercise Software	5
2.4 Test Procedure	5
Figure 2.1 Configuration of Tested System	6
<b>3 RADIATED MEASUREMENT PHOTOS</b>	<b>7</b>
Figure 3.1 Radiated Measurement Photos	7
3.1 Measurement Uncertainty	8
<b>4 RADIATED EMISSION DATA</b>	<b>9</b>
4.1 Field Strength Calculation	10
<b>5 TEST EQUIPMENT USED</b>	<b>11</b>
<b>APPENDIX</b>	<b>12</b>
A:Test Data	A1-A2

## 1 GENERAL INFORMATION

APPLICANT : OMRON CORPORATION

TRADE NAME : OMRON

ADDRESS : 6368 Nenjo-Zaka, Okusa, Komaki-City,  
Aichi 485-0802 Japan

Telephon Number : +81-568-78-6170  
Facsimile Number : +81-568-78-6179

REGULATION(S) : FCC Part 15 Subpart B Section 15.109(a)

MODEL NUMBER : G8D-344H-B

FCC ID : OUCG8D-344H-B

SERIAL NUMBER : sample No.1

CONDITION EUT : Engineering Prototype

KIND OF EQUIPMENT : Keyless Entry System (Receiver)

TESTED DATE : July 2, 2001

RECEIPT DATE OF SAMPLE : June 28, 2001

REPORT FILE NUMBER : 21KE0071-YW-2

TEST SITE : A-PEX Yokowa No.3 Open Test Site

## 1.1 Product Description

Model: G8D-344H-B (referred to as the EUT in this report) is a Keyless Entry System (Receiver).

The specification is as following :

Type of receiver : Super Heterodyne  
Receiving Frequency : 313.85MHz  
Local Oscillator Frequency : 324.55 MHz  
Intermediate Frequency : 10.7MHz  
Other Clock Frequency : 5.00MHz  
Information antenna : Integral / L type Wire antenna  
Operation Voltage : DC 12V

## 1.2 Test Specification

Test Specification : FCC Part 15 Subpart B Section 15.109 Radiated emission limits  
Title : FCC 47CFR Part15 Radio Frequency Device  
Subpart B Unintentional Radiators

## 1.3 Methods & Procedures

No.	Item	Test Procedure	Specification	Remarks
1	Conducted emission	ANSI C63.4:1992	§ 15.107(a)	-
2	Radiated emission	ANSI C63.4:1992	§ 15.109(a)	Class B / 3m

## 1.4 Exclusion from standards

No.	Item	Test Procedure	Specification	Remarks
1	Conducted emission	ANSI C63.4:1992	§ 15.107(a)	-

\* This test was not performed since EUT dose not have AC power port.

## 1.5 Test Location

A-PEX International Co.,Ltd. Yokowa No.3 test site  
108 Yokowa-cho, Ise-shi, Mie-ken 516-1106 Japan  
Telephone number : +81-596-39-1485  
Facsimile number : +81-596-39-0232

This site has been fully described in a report submitted to FCC office, and listed on September 12, 2000(Registration number: 90412) .

\*NVLAP Lab. code : 200109-0

Testing Laboratory

**A-pex International Co., Ltd.**

Telephone: +81 596 39 1485

108 Yokowa-cho, Ise-shi Mie-ken 516-1106 JAPAN Facsimile: +81 596 39 0232

## 2 SYSTEM TEST CONFIGURATION

### 2.1 Operation Environment

Temperature : See data  
Humidity : See data  
Power supply : DC 12V

### 2.2 Justification

The system was configured in typical fashion (as a customer would normally use it) for testing.

### 2.3 EUT Exercise Software

The EUT exercise program used during radiated testing was designed to exercise the various system components in a manner similar to typical use.

The sequence is used:

Operation Mode : Receiving

### 2.4 Test Procedure

Tabletop Equipment Radiated Emissions

EUT was placed on a platform of nominal size, 1m by 1m, raised 80cm above the conducting ground plane. Test was made with the antenna positioned in both the horizontal and vertical planes of polarization. The measurement antenna was varied in height above the conducting ground plane to obtain the maximum signal strength. The measurement distance was 3m.

**Figure2.1 Configuration of Tested System**

Front View

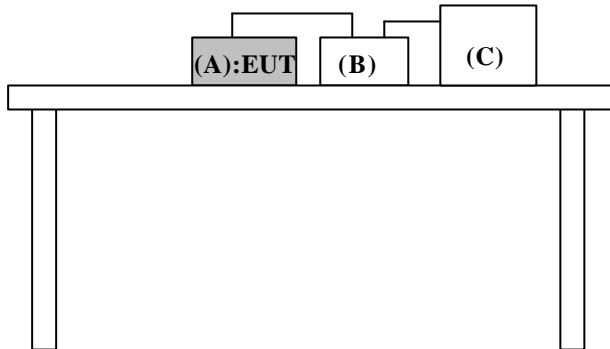

\* Cabling was taken into consideration and test data was taken under worse case conditions.

Top View

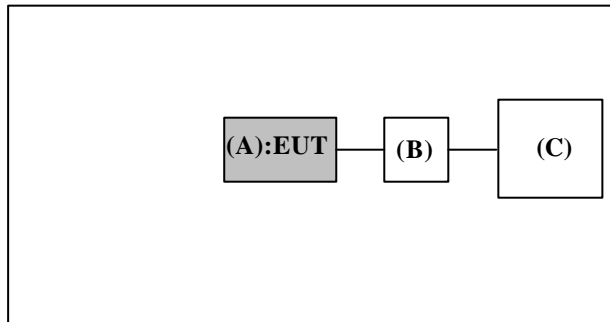

\* Cabling was taken into consideration and test data was taken under worse case conditions.

**Description of EUT and Support Equipment**

No.	Item	Model number	Serial number	Manufacturer	Remark
A	Keyless Entry System (Receiver)	G8D-344H-B	Sample No.1	OMRON Corporation	EUT
B	Checker Box	N/A	N/A	OMRON Corporation	-
C	Car Battery	50B24L	N/A	YUASA	-

**List of cables used**

No.	Name	Length (m)	Shield	Remark
	Signal & DC Power Cable	0.1	N	-
	DC Power Cable	0.5	N	-

Test report

Our reference : 21KE0071-YW-2

Page : 7 of 12

Issued date : July 5, 2001

FCC ID : OUCG8D-344H-B

### 3 RADIATED MEASUREMENT PHOTOS

Figure 3.1 Radiated Measurement Photos

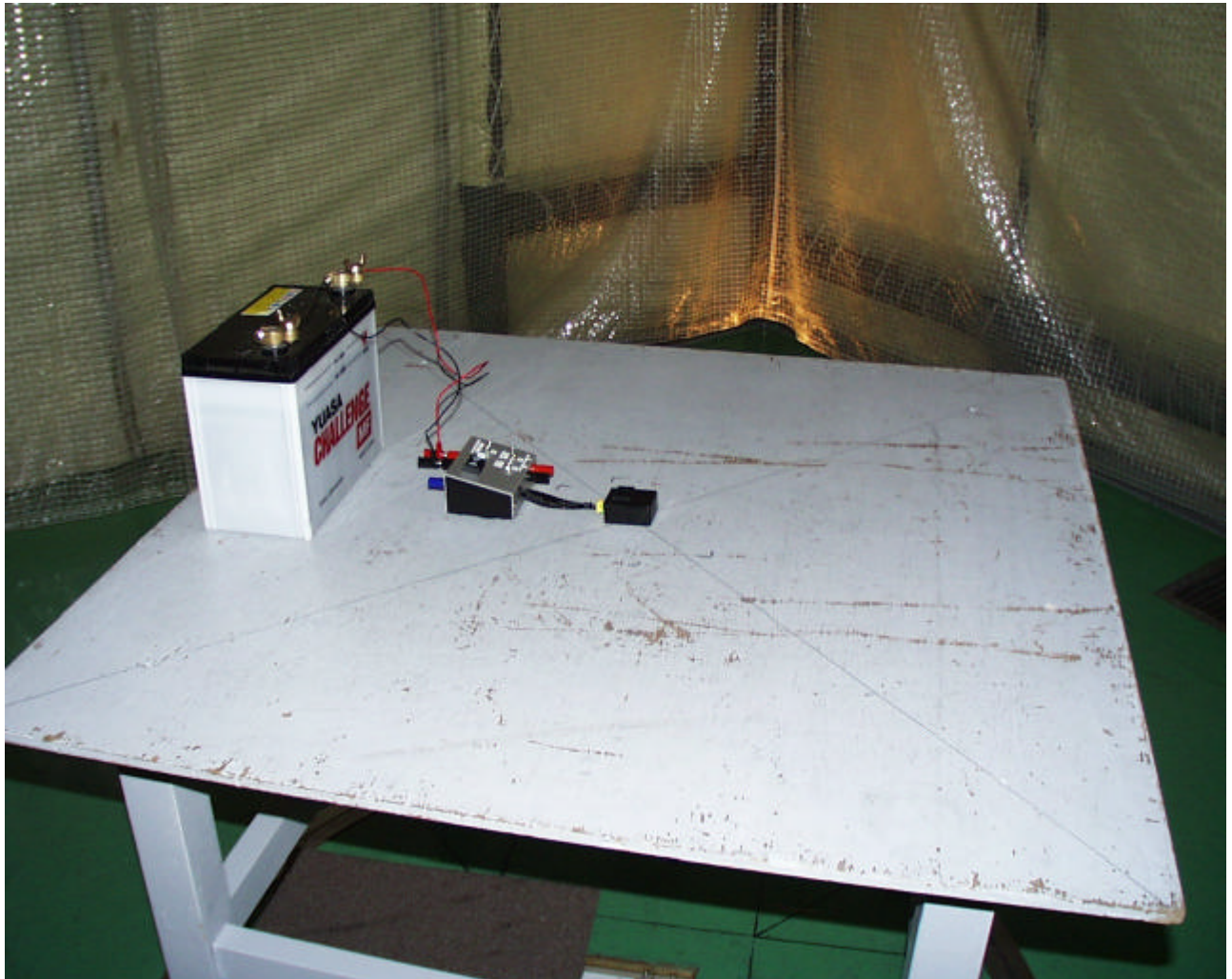

Testing Laboratory

**A-pex International Co., Ltd.**

Telephone: +81 596 39 1485

108 Yokowa-cho, Ise-shi Mie-ken 516-1106 JAPAN Facsimile: +81 596 39 0232

### 3.1 Measurement Uncertainty

#### Radiated Emission Test

The measurement uncertainty (with a 95% confidence level) for this test was  $\pm 3.3\text{dB}$ .

The data listed in this test report may exceed the test limit because it does not have enough margin (more than 3.3dB).

The data listed in this test report has enough margin, more than 3.3d



## 4 RADIATED EMISSION DATA

The initial step in collecting radiated data was a spectrum analyzer peak scan of the measurement range (30MHz-1000MHz).

The final data was reported in the worst-case emissions.

The minimum margin to the limit is as follows :

Frequency (MHz)	Ant Pol	Receiver Reading (dB $\mu$ V)	Correction Factor (dB)	Field Strength (dB $\mu$ V/m)	Limit (dB $\mu$ V/m)	Margin (dB)
649.10	H	21.2	-4.0	25.2	46.0	20.8

\* The test receiver settings for radiated emissions measurement were as follows.

Detector Type : Quasi-Peak (CISPR)

IF Bandwidth : 120kHz

**Test report**

**Our reference : 21KE0071-YW-2**

**Page : 10 of 12**

**Issued date : July 5, 2001**

**FCC ID : OUCG8D-344H-B**

## 4.1 Field Strength Calculation

The field strength is calculated by adding the Antenna Factor, Cable Factor and Antenna Pad, and subtracting the Amplifier Gain from the measured reading. The sample calculation is as follows :

$$FS = RA + AF + CF + AT - AG$$

where FS = Field Strength

RA = Receiver Amplitude

AF = Antenna Factor

CF = Cable Factor

AT = Antenna Pad

AG = Amplifier Gain

Assume a receiver reading of 21.2 dB  $\mu$  V is obtained. The antenna Factor of 19.7 dB, Cable Factor of 5.5 dB and Antenna Pad of 5.9 dB is added. The Amplifier Gain of 27.1 dB is subtracted, giving a field strength of 25.2 dB  $\mu$  V/m.

$$FS = 21.2 + 19.7 + 5.5 + 5.9 - 27.1 = 25.2 \text{ dB } \mu \text{ V/m}$$

Testing Laboratory

**A-pex International Co., Ltd.**

Telephone: +81 596 39 1485

108 Yokowa-cho, Ise-shi Mie-ken 516-1106 JAPAN Facsimile: +81 596 39 0232

Test report

Our reference : 21KE0071-YW-2

Page : 11 of 12

Issued date : July 5, 2001

FCC ID : OUCG8D-344H-B

## 5 Test EQUIPMENT USED

Instrument	Mfr.	Model No.	Control No.	Calibration date // Interval
Pre Amplifier	Hewlett Packard	8447D	AF-01	March 31, 2001 / 1 year
Attenuator	Anritsu	MP721B	AT-06	March 31, 2001 / 1 year
Biconical Antenna	Schwarzbeck	BBA9106	BA-03	May 01, 2001 / 1 year
Logperiodic Antenna	Schwarzbeck	UKLP9108-A	LA-06	May 01, 2001 / 1 year
Spectrum Analyzer	Hewlett Packard	8567A	SA-04	March 31, 2001 / 1 year
Test Receiver	Rohde & Schwarz	ESVS10	TR-06	August 10, 2000 / 1 year

\*All measurement equipment is traceable to national standard.

Testing Laboratory

**A-pex International Co., Ltd.**

Telephone: +81 596 39 1485

108 Yokowa-cho, Ise-shi Mie-ken 516-1106 JAPAN Facsimile: +81 596 39 0232

## APPENDIX

### **A : Test Data**

Radiated emissions (section 15.109)

A1 – A2

# DATA OF RADIATION TEST

A-PEX INTERNATIONAL CO., LTD.  
YOKOWA No.3 OPEN TEST SITE  
Report No. : 21KE0071-YW-2

Applicant : OMRON Corporation  
 Kind of Equipment : Keyless Entry System (Receiver)  
 Model No. : G8D-344H-B  
 Serial No. : Sample No. 1  
 Power : DC 12V  
 Mode : Receiving  
 Remarks : FCC ID: OUCG8D-344H-B  
 Date : 7/2/2001  
 Test Distance : 3 m  
 Temperature : 26 °C  
 Humidity : 48 %  
 Regulation : FCC Part15B CLASS B

  
 \_\_\_\_\_  
 Engineer : Makoto Kosaka

No.	FREQ. [MHz]	ANT TYPE	READING		ANT FACTOR [dB/m]	AMP GAIN [dB]	CABLE LOSS [dB]	ATTEN. [dB]	RESULT		LIMITS [dB μ V/m]	MARGIN [dB]	
			HOR [dB μ V]	VER					HOR [dB μ V/m]	VER		HOR [dB]	VER
1.	60.00	BB	24.8	24.5	7.4	27.9	1.4	5.9	11.6	11.3	40.0	28.4	28.7
2.	150.00	BB	22.2	23.0	14.5	27.8	2.4	5.9	17.2	18.0	43.5	26.3	25.5
3.	200.00	BB	23.3	23.4	16.4	27.8	2.8	5.9	20.6	20.7	43.5	22.9	22.8
4.	324.55	BB	22.2	22.2	14.5	27.6	3.6	5.8	18.5	18.5	46.0	27.5	27.5
5.	649.10	BB	21.2	21.2	19.7	27.1	5.5	5.9	25.2	25.2	46.0	20.8	20.8
6.	973.65	BB	20.4	20.4	23.0	26.7	7.2	5.9	29.8	29.8	54.0	24.2	24.2

CALCULATION: READING + ANT. FACTOR + CABLE LOSS - AMP. GAIN + ATTEN.

All other emissions are more than 20dB below the limits.  
 ANT. TYPE: 30-300MHz Biconical, 300-1000MHz Logperiodic

# DATA OF RADIATION TEST

A-PEX INTERNATIONAL CO., LTD.  
YOKOWA No.3 OPEN TEST SITE  
Report No. : 21KE0071-YW-2

Applicant : OMRON Corporation  
Kind of Equipment : Keyless Entry System (Receiver)  
Model No. : G8D-344H-B  
Serial No. : Sample No. 1  
Power : DC 12V  
Mode : Receiving  
Remarks : FCC ID: OUCG8D-344H-B  
Date : 7/2/2001  
Test Distance : 3 m  
Temperature : 26 °C  
Humidity : 48 %  
Regulation : FCC Part15B CLASS B

  
Engineer : Makoto Kosaka

