



EMI TEST REPORT

Test Report No. : 31EE0173-HO-02-C-R1

Applicant : Omron Corporation
Type of Equipment : ETACS
Model No. : G8C-936M
FCC ID : OUCG8C-936M
Test standard : FCC Part 15 Subpart B: 2010
Test Result : Complied

1. This test report shall not be reproduced in full or partial, without the written approval of UL Japan, Inc.
2. The results in this report apply only to the sample tested.
3. This sample tested is in compliance with the above regulation.
4. The test results in this report are traceable to the national or international standards.
5. This test report must not be used by the customer product certification, approval, or endorsement by NVLAP, NIST, or any agency of the Federal Government.
6. This report is a revised version of 31EE0173-HO-02-C. 31EE0173-HO-02-C is replaced with this report.

Date of test:

February 16, 2011

Representative test engineer:

Motoya Imura
Engineer of WiSE Japan
UL Verification Service

Approved by:

Shinya Watanabe
Leader of WiSE Japan
UL Verification Service



NVLAP LAB CODE: 200572-0

This laboratory is accredited by the NVLAP LAB CODE 200572-0, U.S.A. The tests reported herein have been performed in accordance with its terms of accreditation. *As for the range of Accreditation in NVLAP, you may refer to the WEB address, <http://www.ul.com/japan/jpn/pages/services/emc/about/mark1/index.jsp#nvlap>

UL Japan, Inc.

Head Office EMC Lab.

4383-326 Asama-cho, Ise-shi, Mie-ken 516-0021 JAPAN

Telephone : +81 596 24 8116

Facsimile : +81 596 24 8124

13-EM-F0429

CONTENTS	PAGE
SECTION 1: Customer information	3
SECTION 2: Equipment under test (E.U.T.)	3
SECTION 3: Test specification, procedures & results	5
SECTION 4: Operation of E.U.T. during testing	7
SECTION 5: Radiated Emission	8
APPENDIX 1: Photographs of test setup.....	9
Radiated Emission	9
Worst Case Position (Horizontal: X-axis/ Vertical:X-axis)	10
APPENDIX 2: Data of EMI test	11
Radiated Emission	11
APPENDIX 3: Test instruments	13

SECTION 1: Customer information

Company Name : Omron Corporation
Address : 6368 NEJOZAKA OKUSA KOMAKI AICHI 485-0802 JAPAN
Telephone Number : +81-568-78-6159
Facsimile Number : +81-568-78-7659
Contact Person : Masashi Matsuda

SECTION 2: Equipment under test (E.U.T.)

2.1 Identification of E.U.T.

Type of Equipment : ETACS
Model No. : G8C-936M
Serial No. : Please refer to Section 4 Clause 4.2
Rating : DC12V (Car Battery)
Receipt Date of Sample : February 15, 2011
Country of Mass-production : Japan
Condition of EUT : Production prototype
(Not for Sale: This sample is not mass-produced items.)
Modification of EUT : No Modification by the test lab

UL Japan, Inc.

Head Office EMC Lab.

4383-326 Asama-cho, Ise-shi, Mie-ken 516-0021 JAPAN

Telephone : +81 596 24 8116

Facsimile : +81 596 24 8124

2.2 Product description

Model No: G8C-936M, (referred to as the EUT in this report), is the ETACS.

This EUT is to lock and unlock doors (gate/trunk) by receiving RF signal output by the operation of the registered transmitter (remote transmitter, hereafter referred to as T/M).

Also, the immobilizer function for antitheft and remote engine starter function to start up/stop an engine by where the key is placed to start the engine.

General Specification

Clock frequencies in the system : 8MHz and 32MHz and 10.178125MHz
Power Supply : DC12V

Radio Specification

[Immobilizer part *]

Radio Type : Transceiver
Frequency of Operation : 125kHz
Modulation : BPLM
Antenna type : Coil Antenna
Operating voltage (inner) : DC5.0V

[UHF part]

Equipment type : Receiver
Type of Receiver : Super Heterodyne
Frequency of Operation : 315MHz
Oscillator Frequency : 10.178125MHz (Crystal)
Local Oscillator Frequency : 325.7MHz (10.178125MHz * 32)
Intermediate frequency : 10.7MHz
Antenna type : L type Antenna (Built-in)
Method of Frequency : Crystal
Generation :
Operating voltage (inner) : DC5.0V

*Immobilizer part was tested according to FCC15C standard. Please see UL Japan, Inc. test report No. 31EE0173-H-02-A-R1.

FCC15.111(b)

The receiving antenna (of this EUT) is installed inside the EUT and cannot be removed (permanently attached). Therefore, Radiated emission test was performed.

UL Japan, Inc.

Head Office EMC Lab.

4383-326 Asama-cho, Ise-shi, Mie-ken 516-0021 JAPAN

Telephone : +81 596 24 8116

Facsimile : +81 596 24 8124

SECTION 3: Test specification, procedures & results

3.1 Test specification

Test Specification : FCC Part 15 Subpart B: 2010, final revised on December 6, 2010 and effective January 5, 2011

Title : FCC 47CFR Part15 Radio Frequency Device
Subpart B Unintentional Radiators

3.2 Procedures and results

Item	Test Procedure	Limits	Deviation	Worst margin	Result
Conducted emission	FCC: ANSI C63.4: 2003 7. AC powerline conducted emission measurements	Receiver	N/A *1)	N/A	N/A
Radiated emission	FCC: ANSI C63.4: 2003 8. Radiated emission measurements	Receiver	N/A	20.3dB 846.440MHz, QP, Vertical/Horizontal	Complied

*Note: UL Japan, Inc's EMI Work Procedure 13-EM-W0420.

*1) The test is not applicable since the EUT is not the device that is designed to be connected to the public utility (AC) power line.

3.3 Addition to standard

No addition, exclusion nor deviation has been made from the standard.

3.4 Uncertainty

EMI

The following uncertainties have been calculated to provide a confidence level of 95% using a coverage factor k=2.

Test room (semi-anechoic chamber)	Radiated emission						
	(3m*)(+dB)				(1m*)(+dB)		(0.5m*)(+dB)
	9kHz -30MHz	30MHz -300MHz	300MHz -1GHz	1GHz -10GHz	10GHz -18GHz	18GHz -26.5GHz	26.5GHz -40GHz
No.1	3.5dB	5.1dB	5.2dB	4.8dB	5.1dB	4.4dB	4.3dB
No.2	4.0dB	5.1dB	5.2dB	4.8dB	5.0dB	4.3dB	4.2dB
No.3	4.2dB	4.7dB	5.2dB	4.8dB	5.0dB	4.5dB	4.2dB
No.4	4.0dB	5.0dB	5.1dB	4.8dB	5.0dB	5.1dB	4.2dB

*3m/1m/0.5m = Measurement distance

Radiated emission test(3m)

The data listed in this test report has enough margin, more than the site margin.

UL Japan, Inc.

Head Office EMC Lab.

4383-326 Asama-cho, Ise-shi, Mie-ken 516-0021 JAPAN

Telephone : +81 596 24 8116

Facsimile : +81 596 24 8124

3.5 Test Location

UL Japan, Inc. Head Office EMC Lab. *NVLAP Lab. code: 200572-0
 4383-326 Asama-cho, Ise-shi, Mie-ken 516-0021 JAPAN
 Telephone : +81 596 24 8116 Facsimile : +81 596 24 8124

	FCC Registration Number	IC Registration Number	Width x Depth x Height (m)	Size of reference ground plane (m) / horizontal conducting plane	Other rooms
No.1 semi-anechoic chamber	313583	2973C-1	19.2 x 11.2 x 7.7m	7.0 x 6.0m	No.1 Power source room
No.2 semi-anechoic chamber	655103	2973C-2	7.5 x 5.8 x 5.2m	4.0 x 4.0m	-
No.3 semi-anechoic chamber	148738	2973C-3	12.0 x 8.5 x 5.9m	6.8 x 5.75m	No.3 Preparation room
No.3 shielded room	-	-	4.0 x 6.0 x 2.7m	N/A	-
No.4 semi-anechoic chamber	134570	2973C-4	12.0 x 8.5 x 5.9m	6.8 x 5.75m	No.4 Preparation room
No.4 shielded room	-	-	4.0 x 6.0 x 2.7m	N/A	-
No.5 semi-anechoic chamber	-	-	6.0 x 6.0 x 3.9m	6.0 x 6.0m	-
No.6 shielded room	-	-	4.0 x 4.5 x 2.7m	4.75 x 5.4 m	-
No.6 measurement room	-	-	4.75 x 5.4 x 3.0m	4.75 x 4.15 m	-
No.7 shielded room	-	-	4.7 x 7.5 x 2.7m	4.7 x 7.5m	-
No.8 measurement room	-	-	3.1 x 5.0 x 2.7m	N/A	-
No.9 measurement room	-	-	8.0 x 4.5 x 2.8m	2.0 x 2.0m	-
No.10 measurement room	-	-	2.6 x 2.8 x 2.5m	2.4 x 2.4m	-
No.11 measurement room	-	-	3.1 x 3.4 x 3.0m	2.4 x 3.4m	-

* Size of vertical conducting plane (for Conducted Emission test) : 2.0 x 2.0m for No.1, No.2, No.3, and No.4 semi-anechoic chambers and No.3 and No.4 shielded rooms.

3.6 Test set up, Data of EMI, and Test instruments

Refer to APPENDIX.

SECTION 4: Operation of E.U.T. during testing

4.1 Operating modes

Mode	Remarks
Receiving mode	* Transmitter was operated manually by a test engineer and the test was performed with the EUT receiving 315MHz.

4.2 Configuration and peripherals

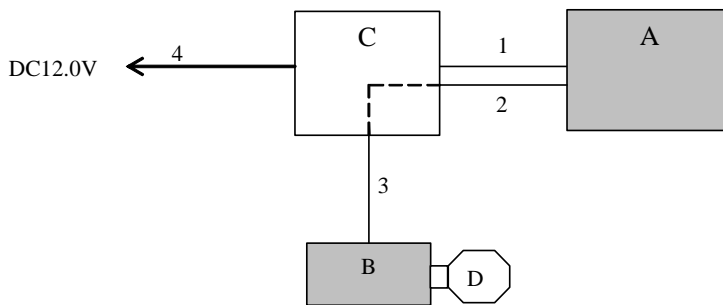

* Cabling and setup were taken into consideration and test data was taken under worse case conditions.

Description of EUT and Support equipment

No.	Item	Model number	Serial number	Manufacturer	Remarks
A	ETACS	G8C-936M	01Z0D1	Omron Corporation	EUT
B	Key Cylinder	-	No.1	Omron Corporation	EUT
C	Simulator	-	-	-	-
D	Transponder *1)	-	-	Omron Corporation	-

*1) This transponder is auxiliary (function) of Keyless Transmitter (Model No.G8D-571M-A).

The test was performed without Item D, because it was the worst case as a result of comparison with the test with Item D inserted into Item B.

List of cables used

No.	Name	Length (m)	Shield		Remarks
			Cable	Connector	
1	Signal & DC Cable	1.5	Unshielded	Unshielded	-
2	Signal Cable	1.5	Unshielded	Unshielded	*2)
3	Signal Cable	0.4	Unshielded	Unshielded	*2)
4	DC Cable	1.5	Unshielded	Unshielded	-

*2) No.2 and 3 Signal Cables pass through the No. C: Simulator.

UL Japan, Inc.

Head Office EMC Lab.

4383-326 Asama-cho, Ise-shi, Mie-ken 516-0021 JAPAN

Telephone : +81 596 24 8116

Facsimile : +81 596 24 8124

SECTION 5: Radiated Emission

5.1 Operating environment

Test place : No.3 semi anechoic chamber
Temperature : See data
Humidity : See data

5.2 Test configuration

EUT was placed on a urethane platform of nominal size, 1.0m by 1.5m, raised 0.8m above the conducting ground plane. The EUT was set on the center of the tabletop.
Test was made with the antenna positioned in both the horizontal and vertical planes of polarization. The measurement antenna was varied in height above the conducting ground plane to obtain the maximum signal strength. Photographs of the set up are shown in Appendix 1.

5.3 Test conditions

Frequency range : 30MHz-300MHz (Biconical antenna) / 300MHz-1000MHz (Logperiodic antenna)
1000MHz -2000MHz (Horn antenna)
Test distance : 3m
EUT position : Table top
EUT operation mode : See Clause 4.1

5.4 Test procedure

The height of the measuring antenna varied between 1 and 4m and EUT was rotated a full revolution in order to obtain the maximum value of the electric field intensity.
The measurements were performed for both vertical and horizontal antenna polarization with the Test Receiver, or the Spectrum Analyzer.
The radiated emission measurements were made with the following detector function of the test receiver and the Spectrum analyzer.

Frequency	Below 1GHz	Above 1GHz
Instrument used	Test Receiver	Spectrum Analyzer *1)
IF Bandwidth	QP: BW 120kHz	PK: RBW:1MHz/VBW: 3MHz AV *2): RBW:1MHz/VBW:10Hz

*1) The Spectrum Analyzer was used in 3dB resolution bandwidth.

*2) When using Spectrum analyzer, the test was made with adjusting span to zero by using peak hold.

The noise levels were confirmed at each position of X, Y and Z axes of EUT to see the position of maximum noise, and the test was made at representative X-axis since no difference was found among each position.

5.5 Test result

Summary of the test results: Pass

Date: February 16, 2011

Test engineer: Motoya Imura

UL Japan, Inc.

Head Office EMC Lab.

4383-326 Asama-cho, Ise-shi, Mie-ken 516-0021 JAPAN

Telephone : +81 596 24 8116

Facsimile : +81 596 24 8124