

| NO. | NAME | QTY |
|-----|-----------|-----|
| 1 | CASE | 1 |
| 2 | COVER | 1 |
| 3 | COIL ASSY | 1 |
| 4 | PCB ASSY | 1 |
| 5 | ANTENNA | 1 |

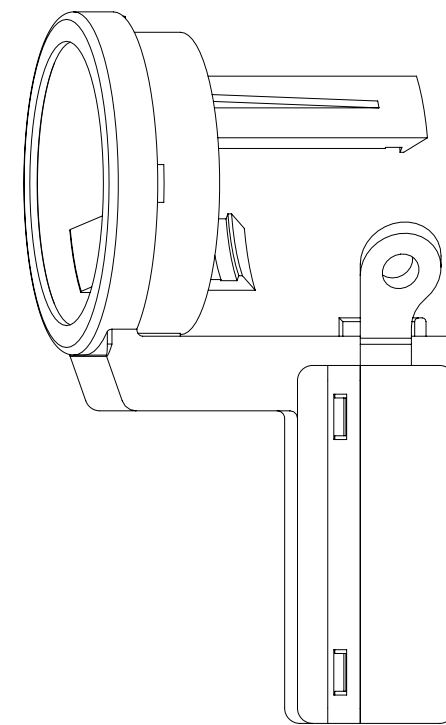

SERIAL NUMBER
 [T=DATA IDENTIFIER
 OM=SUPPLIER CODE
 FX=COMPONENT CODE
 DDD=DAY OF YEAR
 Y=LAST DIGIT OF YEAR
 L=LINE NO. (1 OR 2)
 XXXX=SERIAL #(0001-9999)]

IC: 850K-11543680
 MODEL/FCC ID: OUC-11543680
 OMRON P/N: 1154307-8
 DCX P/N: 68140642AB
 T0MF.XDDYL.XXXX

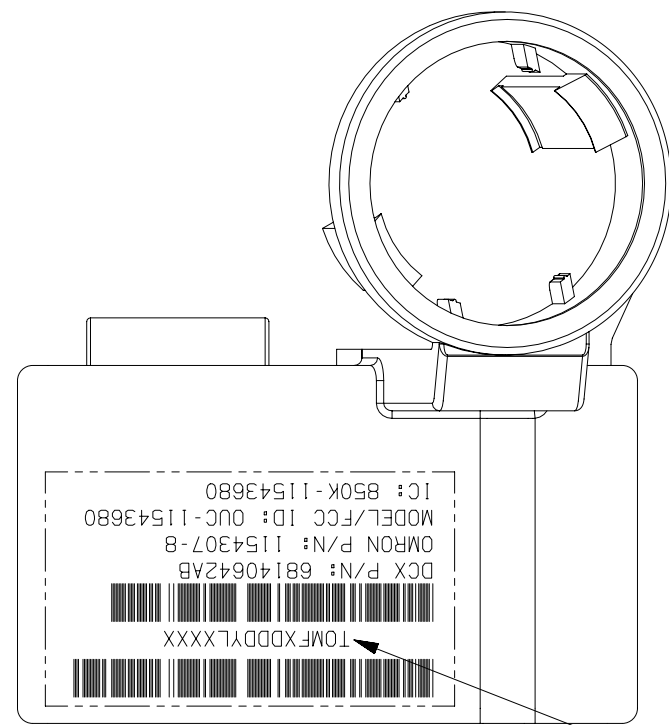
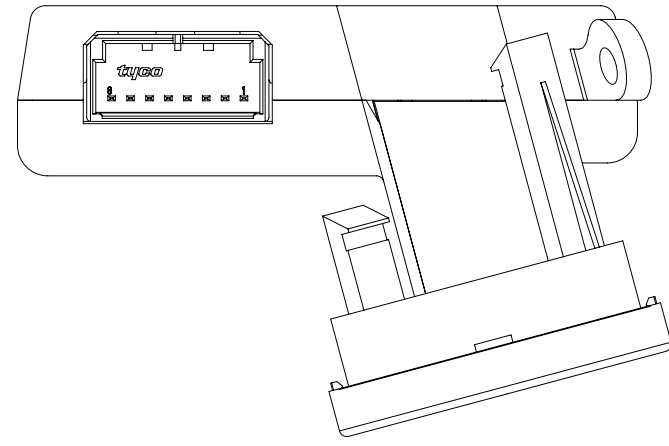
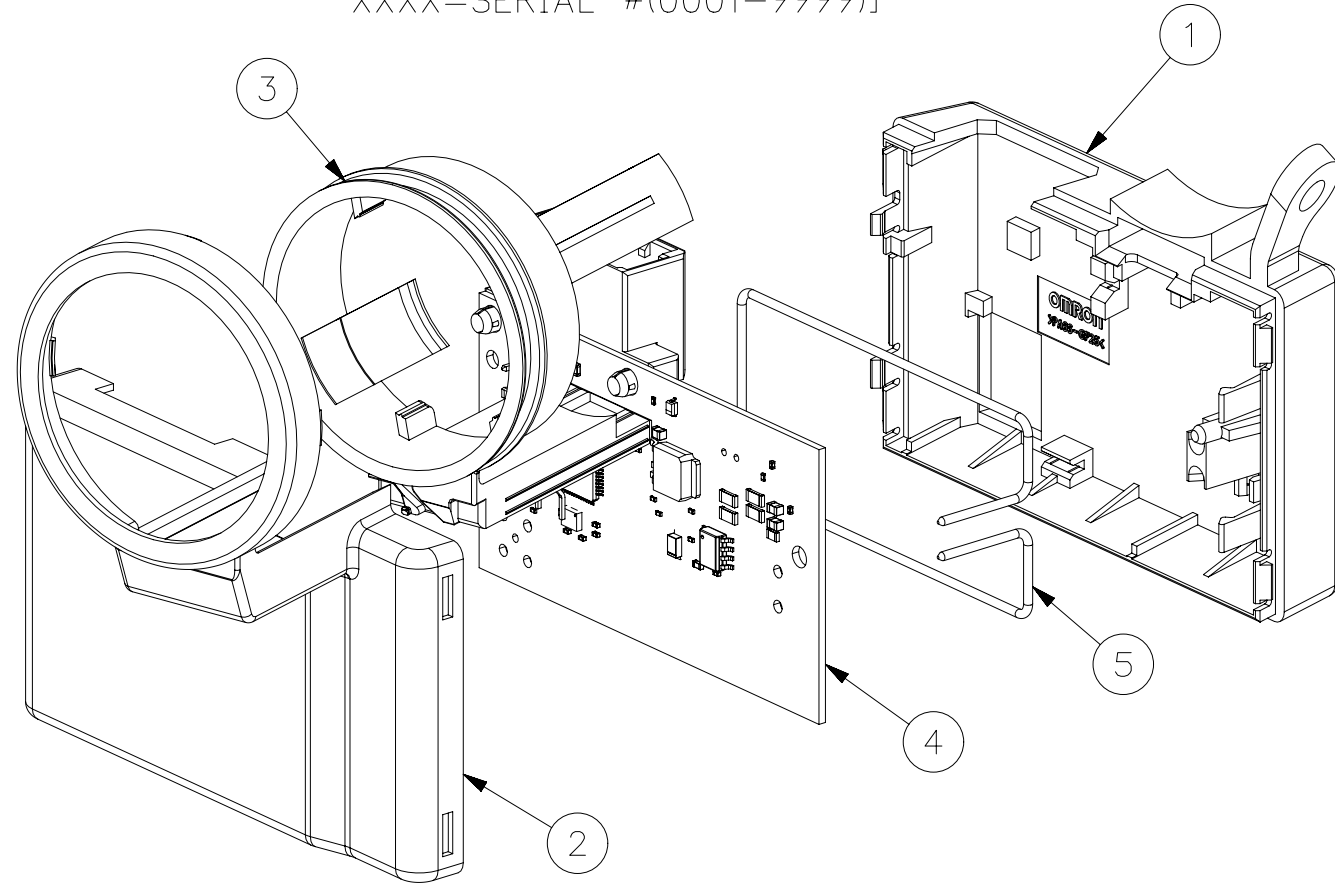

- ASSEMBLY INSTRUCTIONS
- (1) INSERT ANTENNA (5) INTO CASE (1).
 - (2) INSERT PCB ASSY (4) OVER ANTENNA (5) AND SNAP INTO CASE (1).
 - (3) PLACE COIL ASSY (3) INTO CASE (1) AND SOLDER ONTO PCB ASSY (4). SOLDER ANTENNA (5) TO PCB ASSY (4).
 - (4) PLACE COVER (2) OVER COIL ASSY (3) AND CASE (1) AND SNAP IN PLACE.

| | | | | | | | | | | | | |
|-----|----------|--------------|------------|------|-----------------------------------|--------------------------------------|---------------------------------------|--------------------------|-----------------|--|---------------------------------|--|
| | | | | | MATERIAL | | | | SCALE | | ASSY DRWG | |
| | | | | | FINISH | | | | 1:1 | | | |
| | | | | | TOLERANCES UNLESS SPECIFIED | | | | 3RD ANGLE SHEET | | DRWG NO. 1154369-8 A | |
| | | | | | | | | | 1/1 | | DESIGNED FOR CHRYSLER WCM GEN 3 | |
| A | 06-21-12 | NEW DRWG | UE-P120117 | JTH | DESIGNED OEDC ENGINEERING R.SPEAR | CHECKED OEDC ENGINEERING J.HREHORIAK | APPROVED OEDC ENGINEERING J.HREHORIAK | COMPUTER GENERATED IN UG | | | | |
| SYM | DATE | E/C CONTENTS | E/C NO. | SIGN | | | | | | | | |